

Analiza utroška materijala čelične hale

Vrkić, Josip

Undergraduate thesis / Završni rad

2019

Degree Grantor / Ustanova koja je dodijelila akademski / stručni stupanj:

University of Split, Faculty of Civil Engineering, Architecture and Geodesy / Sveučilište u Splitu, Fakultet građevinarstva, arhitekture i geodezije

Permanent link / Trajna poveznica: <https://um.nsk.hr/um:nbn:hr:123:733146>

Rights / Prava: [In copyright](#)/[Zaštićeno autorskim pravom.](#)

Download date / Datum preuzimanja: **2024-12-02**



Repository / Repozitorij:

[FCEAG Repository - Repository of the Faculty of Civil Engineering, Architecture and Geodesy, University of Split](#)



UNIVERSITY OF SPLIT



SVEUČILIŠTE U SPLITU
FAKULTET GRAĐEVINARSTVA, ARHITEKTURE I GEODEZIJE

ZAVRŠNI RAD

VRKIĆ JOSIP

SPLIT, 2019.

SVEUČILIŠTE U SPLITU
FAKULTET GRAĐEVINARSTVA, ARHITEKTURE I GEODEZIJE

VRKIĆ JOSIP

ANALIZA UTROŠKA MATERIJALA ČELIČNE HALE

ZAVRŠNI RAD

SPLIT, 2019.

SVEUČILIŠTE U SPLITU

FAKULTET GRAĐEVINARSTVA, ARHITEKTURE I GEODEZIJE

Split, Matice hrvatske 15

STUDIJ: **PREDDIPLOMSKI STUDIJ GRAĐEVINARSTVA**
KANDIDAT: **VRKIĆ JOSIP**
BROJ INDEKSA: **4654**
KATEDRA: **KATEDRA ZA METALNE I DRVENE KONSTRUKCIJE**
PREDMET: **METALNE KONSTRUKCIJE**

ZADATAK ZA ZAVRŠNI RAD

Opis zadatka: Na zadanim podlogama potrebno je analizirati 2 varijante glavne nosive konstrukcije s aspekta utroška materijala u pojedinoj varijanti.

Način izvedbe: **montažno**
Materijal izrade: **S235**
Razmak okvira **6,5 m**

OBJEKT SE NALAZI NA PODRUČJU SPLITA

U Splitu, 24.9.2019.

Voditelj završnog rada:

Prof.dr.sc. Ivica Boko

ANALIZA UTROŠKA MATERIJALA ČELIČNE HALE

Sažetak:

Predmet završnog rada je čelična konstrukcija proizvodne hale smještena u Splitu. Na temelju zadanih podataka, potrebno je dimenzionirati glavnu nosivu konstrukciju, sekundarne krovne i bočne nosače, spregove konstrukcije, spojeve i temelje. Dimenzioniranje elemenata konstrukcije i prethodna mu statička analiza ravninskog okvira provedena je pomoću programa "Scia Engineer 17". Svi proračuni konstrukcije izvedeni su prema norama EUROCODE-a.

Ključne riječi:

Čelik, hala, nosiva konstrukcija, spregovi, podrožnice, greda, stup, dimenzioniranje, spojevi, temelji.

Consumption analysis of a steel manufacturing hall

Abstract:

Subject of this paper is the design of a steel manufacturing hall situated in Split. Based on the given data, it is necessary to dimension the construction's supporting capacity, secondary roof and lateral carrier, bracings of the construction, connections and its substructure. Measuring of the construction's elements and previous static analysis of the planar frame were conducted through the "Scia Engineer 17" programme. All calculations regarding the construction were done according to the EUROCODE norms.

Keywords:

Steel, hall, load-bearing structure, bracings, purlins, beam, column, design, joints, substructures.

SADRŽAJ

SADRŽAJ

1. TEHNIČKI OPIS	1
1.1 MATERIJAL	1
1.2 KONSTRUKTIVNO RJEŠENJE HALE	1
1.3 STATIČKA ANALIZA HALE	1
1.4 OPIS KONSTRUKTIVNIH ELEMENATA	2
1.5 MONTAŽA I TRANSPORT	3
1.6 ZAŠTITA OD KOROZIJE	3
2. ANALIZA OPTEREĆENJA	4
2.1 STALNO OPTEREĆENJE – KROVNA PLOHA	4
2.2 PROMJENJIVO OPTEREĆENJE	5
3. KONTROLA PROGIBA	13
4. DIJAGRAMI REZNIH SILA	15
5. ODABRANI PRESJECI	20
6. DIMENZIONIRANJE	21
6.1 DIMENZIONIRANJE GLAVNE KONSTRUKCIJE	21
6.2 DIMENZIONIRANJE SEKUNDARNE KONSTRUKCIJE	33
6.3 DIMENZIONIRANJE SPREGOVA	56
7. DIMENZIONIRANJE SPOJEVA	58
7.1 UPETI SPOJ STUP – TEMELJ	58
7.2 DIMENZIONIRANJE SPOJA STUP-GREDA	63
7.3 DIMENZIONIRANJE SPOJA NASTAVKA KROVNIH I BOČNIH PODR.	66
7.4 DIMANZIONIRANJE SPOJA SEKUNDARNE NA GLAVNU KONSTR.	72
7.5 DIMENZIONIRANJE SPOJA KROVNIH I BOČNIH SPREGOVA	75
8. PRORAČUN TEMELJA	79
9. LITERATURA	81
10. NACRTI	82

1. TEHNIČKI OPIS

Zadatkom je predviđena izrada proračuna metalne hale tlocrtnih dimenzija 18 m x 65 m, te ukupne visine 8,54 m. nalazi se na području grada Splita. Krovna ploha je u odnosu na horizontalnu ravninu nagnuta pod kutom $\alpha = 3,43^\circ$, što je ekvivalentno padu od 6%. Projektirana je za potrebe skladištenja.

1.1 MATERIJAL

Metalni elementi su izrađeni od čelika S235. Spojevi su izvedeni vijcima k.v. 8.8 kod upetog spoja stup-temelj, te vijcima k.v. 8.8 kod spoja stup-greda.

1.2. KONSTRUKTIVNO RJEŠENJE HALE

Konstrukcija je zamišljena kao okvirni sustav od 11 jednakih okvira razmaknutih za 6.5 m. Prilikom analize opterećenja za zadanu konstrukciju uzeto je da se objekt nalazi na području grada Splita koje spada u zonu III za opterećenje snijegom i u zonu III za opterećenje vjetrom. Prostorna stabilizacija konstrukcije predviđena je spregovima.

1.3 STATIČKA ANALIZA

Proračun je napravljen prema EURONORMAMA - HRN EN 1991 (Eurocode3). Konstrukcija je izložena djelovanju slijedećih opterećenja: vjetar, snijeg, vlastita težina. Građevina se nalazi na području Splita, u III. vjetrovnoj zoni, a lokalna kategorija terena je III. Odgovarajući koeficijenti za vjetar i za snijeg uzeti su prema tome iz propisanih tablica. Za statički proračun su uzete kombinacije s najvećim utjecajem. Proračun reznih sila je izveden u računalnom programu Scia Engineer 17.

Granično stanje uporabljivosti je zadovoljeno uvjetima :

Najveća vertikalna deformacija je manja od ograničenja: $\delta_{\max} = 56,4 \text{ mm} < H/300 = 60 \text{ mm}$.
Najveći horizontalni pomak je manji od ograničenja: $\delta_{\max} = 29,1 \text{ mm} < L/150 = 53,33 \text{ mm}$

1.4. OPIS KONSTRUKTIVNIH ELEMENATA

STUPOVI

Predviđeni su stupovi kao europski širokopojasni vrućevaljani I profili HEA 320. Stupovi su oslonjeni na betonske temelje, tako da je na njihovom spoju upotrebljena čelična ploča dimenzija 600 x 340 x 40 mm. Stupovi su vezani za temelj vijcima M-30. Dimenzije i armaturatemelja su analizirani u proračunu temelja.

GREDA

Predviđene su grede kao europski širokopojasni vrućevaljani I profili HEA 340. Grede su oslonjeni na stupove, tako da je na njihovom spoju upotrebljena čelična ploča dimenzija 680 x 320 x 20 mm sa ukrutom.

SEKUNDARNI NOSAČI (PODROŽNICE)

Podrožnica prenosi opterećenje sa krovne plohe na primarne nosače (gornji pojas rešetke). Podrožnice su vijcima vezane za nosač. Također je predviđena i zidna sekundarna konstrukcija na koju se naslanjaju zidni paneli za zatvaranje konstrukcije. Proračunate su krovne podrožnice profila HEA 160A i bočne podrožnice profila HEA 160A.

SPREGOVI

Za prostornu stabilizaciju ovog objekta korišteni su horizontalni ili krovni spregovi i vertikalni ili bočni spregovi koji služe za prijenos horizontalnih sila preko konstrukcije na temelje objekta. Polja za vertikalno ukrućenje (bočni spregovi) smješteni su u prvom i posljednjem polju konstrukcije.

Osnovni zadatak spregova je stabilizacija čelične hale i to na način da ne bude ugrožena cjelovita stabilnost objekta. Kao dijagonale krovnog sprega proračunati su profili Ø 14. Kao dijagonale bočnog sprega proračunati su profili Ø 18.

1.5. MONTAŽA I TRANSPORT

Pozicije okvira kao što je prikazano u radioničkom nacrtu glavnog okvira će se izrezati u radionici te transportirati na gradilište i zatim montirati (montažni način izgradnje). Pri tome je potrebno obratiti posebnu pažnju na montažu i transport da bi se izbjegla nepotrebna oštećenja. Izvođač je dužan izraditi plan montaže nosača kojeg treba zajedno sa transportnim planom dostaviti nadzornoj službi na suglasnost. Potrebno je poduzeti sve mjere u skladu s "Pravilnikom o zaštiti na radu".

1.6. ZAŠTITA OD KOROZIJE

Svi dijelovi čelične konstrukcije moraju biti zaštićeni od korozije prema odredbama "Pravilnika o tehničkim mjerama i uvjetima za zaštitu čelične konstrukcije od korozije". Kao vrsta zaštite od korozije odabrana je zaštita vrućim cinčanjem i premazom boja.

2. ANALIZA OPTEREĆENJA

$$x = L/8 = 2,25\text{m} = 2250 \text{ mm}$$

Nagib krovne plohe: 6 %

$$\text{tg } \alpha = 6/100 \rightarrow \alpha = 3,43^\circ \rightarrow \alpha = 5,0^\circ$$

2.1 STALNO OPTEREĆENJE – KROVNA PLOHA

STALNO DJELOVANJE

NA KROV:

$$\Delta g = 0,50 \text{ kn/m}^2 \text{ (sekundarna konstrukcija + paneli + instalacije)}$$

$$G = \Delta g \cdot n \cdot x = 0,5 \cdot 6,5 \cdot 2,25 = 7,31 \text{ kN}$$

NA STUP:

$$\Delta g = 0,50 \text{ kn/m}^2 \text{ (sekundarna konstrukcija + paneli + instalacije)}$$

$$G = \Delta g \cdot n = 0,5 \cdot 6,5 = 3,25 \text{ kN}$$

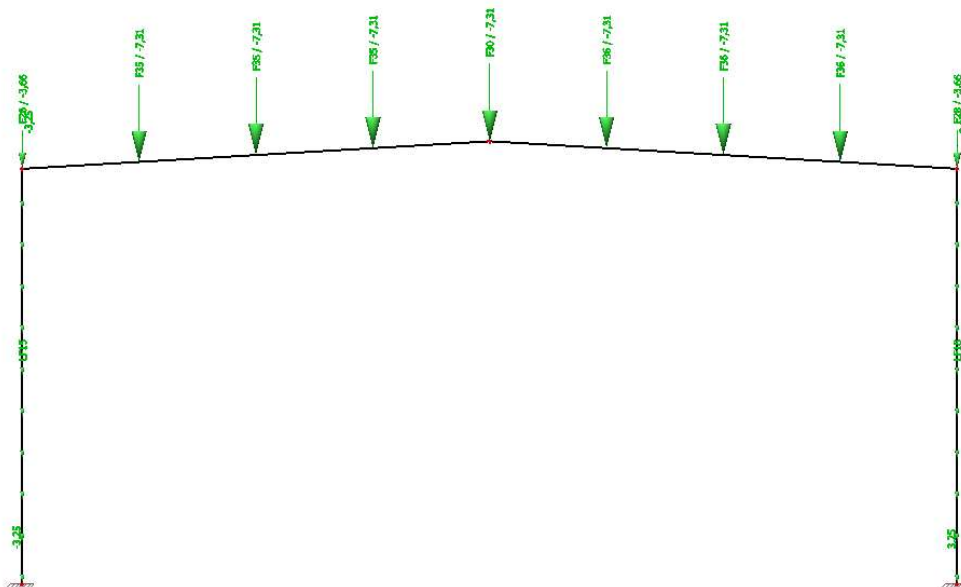

Slika 2.1 Stalno opterećenje na konstrukciju

2.2 PROMJENJIVO OPTEREĆENJE

2.2.1 DJELOVANJE SNIJEGA

$$S = s_k \cdot \mu_i \cdot C_e \cdot C_t [\text{kN/m}^2]$$

μ_i - koeficijent oblika opterećenja snijegom

s_k - karakteristična vrijednost opterećenja snijegom na tlu u kN/m^2

C_e - koeficijent izloženosti (obično se usvaja vrijednost 1,0)

C_t - toplinski koeficijent (obično se usvaja vrijednost 1,0)

$s_k = 0,50 \text{ kN/m}^2 \rightarrow$ za Split

Nagib krova:

μ_i - koeficijent oblika za opterećenje snijegom, očitamo ga ovisno o α , α je nagib krova

$\mu_i = 0,8 \rightarrow$ za nagib krova $0^\circ < \alpha < 15^\circ$

$$\alpha_1 = \alpha_2$$

Opterećenje snijegom preko cijele krovne površine:

$$s_k = 0,50 \cdot 0,8 \cdot 1,0 \cdot 1,0 = 0,4 [\text{kN/m}^2]$$

$$S = s_k \cdot n \cdot x' = 0,4 \cdot 6,5 \cdot 2,25 = 5,85 \text{ kN}$$

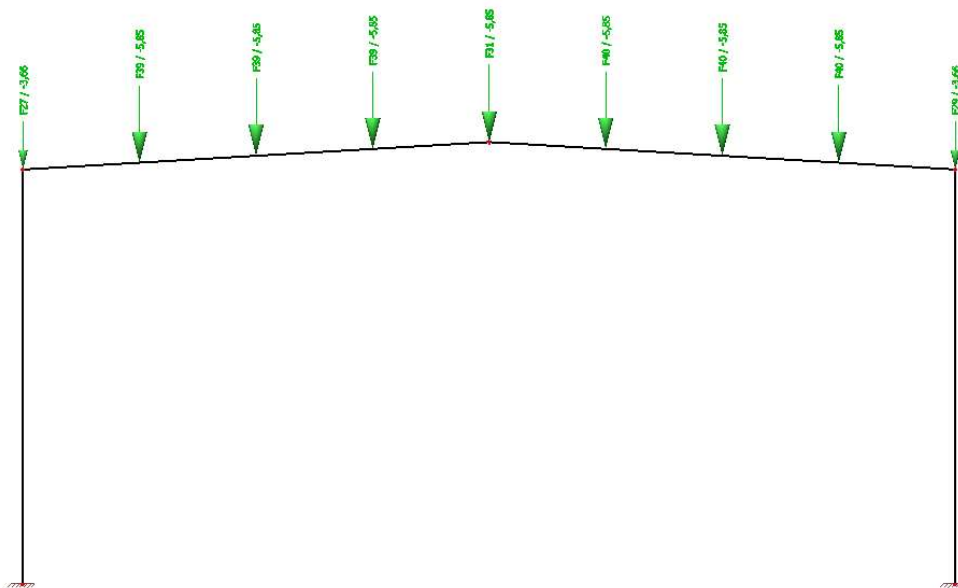

Slika 2.2.1 Opterećenje od snijega na konstrukciju

2.2.2 PRORAČUN DJELOVANJA VJETRA

Pritisak vjetra na vanjske površine: $w_e = q_p|z_e| \cdot c_{pe}$ (kN/m²)

Pritisak vjetra na unutarnje površine: $w_e = q_p|z_i| \cdot c_{pi}$ (kN/m²)

$q_p|z_e|$ → pritisak vjetra pri udaru

$z_{e(i)}$ → referentna visina za vanjski (unutarnji) pritisak

c_{pe} → vanjski koeficijent pritiska

c_{pi} → unutarnji koeficijent pritiska

Određivanje pritiska brzine vjetra pri udaru

Osnovni pritisak vjetra q_b određuje se prema formuli:

$$q_b = \frac{1}{2} \cdot \rho \cdot v_b^2 \text{ [kN/m}^2\text{]}$$

gdje je:

ρ - gustoća zraka (usvaja se vrijednost iz propisa 1,25 kg/m³)

v_b - osnovna brzina vjetra (Split $v_{b0} = 35$ m/s)

$$q_b = \frac{1}{2} \cdot \rho \cdot v_b^2 = \frac{1}{2} \cdot 1,25 \cdot 35^2 = 765,63 \text{ N/m}^2$$

Osnovna brzina vjetra v_b računa se dalje prema izrazu:

$$v_b = c_{dir} \cdot c_{season} \cdot v_{b,0} \text{ [m/s]}$$

gdje je:

$v_{b,0}$ – fundamentalna vrijednost osnovne brzine vjetra (očitava se iz karte)

c_{dir} – faktor smjera vjetra (obično se uzima 1,0)

c_{season} – faktor doba godine (obično se uzima 1,0).

$$v_b = c_{dir} \cdot c_{season} \cdot v_{b,0} = 1,0 \cdot 1,0 \cdot 35,0 = 35,0 \text{ m/s}$$

z - visina konstrukcije

$$z = H + h_1 + h_2$$

$$z = 6,5 + 1,5 + 0,54 = 8,54 \text{ m}$$

III. kategorija terena + z $\rightarrow C_e(z)=1,50$

Pritisak brzine vjetra pri udaru $q_p(z)$ se računa kao:

$$q_p|z| = c_e|z| \cdot q_b = 1,5 \cdot 765,63 = 1148,45 \text{ N/m}^2 = 1,148 \text{ kN/m}^2$$

Određivanje koeficijenta pritiska vjetra

- koeficijent vanjskog pritiska c_{pe}
- za vertikalne zidove

$e = b$ ili $2h$ (odabire se manja vrijednost) = 65 ili 17,08 $\rightarrow e = 17,08 \text{ m}$

$$b = 10x n = 10 \cdot 6,5 = 65 \text{ m}$$

$$e > L = 17,08 < 18,00 \text{ m}$$

$$h / L = 8,54 / 18 = 0,47$$

h/d	D	E
0,46	+ 0,8	- 0,50

Za krovna područja (dvostrešni krov)

α	F	G	H	I	J
5,0°	- 1,7 + 0,0	- 1,2 + 0,0	- 0,6 + 0,0	- 0,6	+ 0,2 - 0,6

Koeficijent unutarnjeg pritiska c_{pi}

$$C_{pi} = 0,2 \rightarrow W_{i1} = q_p \cdot (0,2) = 1,148 \cdot 0,2 = 0,23 \text{ kN/m}^2$$

$$C_{pi} = - 0,3 \rightarrow W_{i2} = q_p \cdot (- 0,3) = 1,148 \cdot (- 0,3) = - 0,34 \text{ kN/m}^2$$

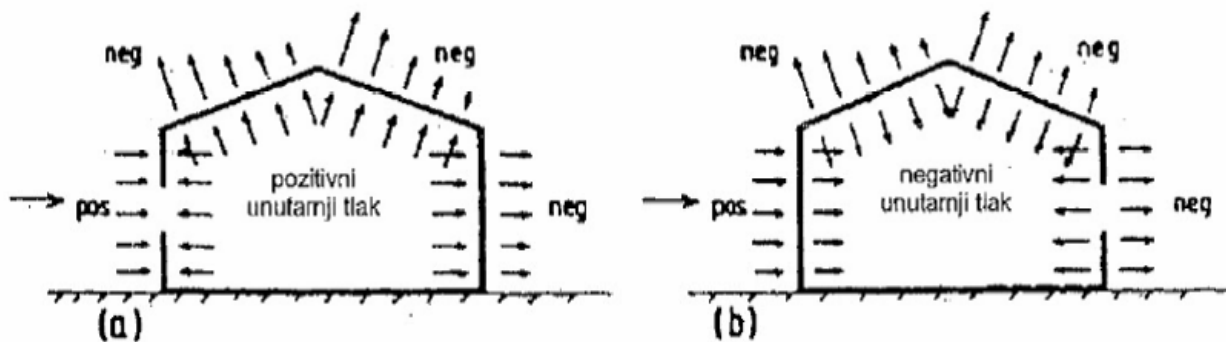

PODRUČJE	D	E	F	G	H	I	J
C_{pe1}	0,8	-0,5	-1,7	-1,2	-0,6	-0,6	0,2
C_{pe2}	0,8	-0,5	0	0	0	-0,6	-0,6
W_{e1}	0,92	-0,57	-1,95	-1,38	-0,69	-0,69	0,23
W_{e2}	0,92	-0,57	0,00	0,00	0,00	-0,69	-0,69
$W1 (W_{e1} "+" W_{i1})$	0,69	0,80	-2,18	-1,61	-0,92	-0,92	0,00
$W2 (W_{e1} "+" W_{i2})$	1,26	-0,23	-1,61	-1,03	-0,34	-0,34	0,57
$W3 (W_{e2} "+" W_{i1})$	0,69	-0,80	-0,23	-0,23	-0,23	-0,92	-0,92
$W4 (W_{e2} "+" W_{i2})$	1,26	-0,23	0,34	0,34	0,34	-0,34	-0,34

IZNOS KONCENTRIRANIH SILA:

ZONA D (stup):

$$W_1 = 0,69 \cdot n = 0,69 \cdot 6,5 = 4,485 \text{ kN/m'}$$

$$W_2 = 1,26 \cdot n = 1,26 \cdot 6,5 = 8,19 \text{ kN/m'}$$

ZONA E (stup):

$$W_1 = -0,80 \cdot n = -0,80 \cdot 6,5 = -5,2 \text{ kN/m'}$$

$$W_2 = -0,23 \cdot n = -0,23 \cdot 6,5 = -1,5 \text{ kN/m'}$$

ZONA F:

$$W_1 = -2,18 \cdot n \cdot a' = -2,18 \cdot 6,5 \cdot 2,25 = -31,88 \text{ kN}$$

$$W_4 = 0,34 \cdot n \cdot a' = 0,34 \cdot 6,5 \cdot 2,25 = 4,97 \text{ kN}$$

ZONA G:

$$W_1 = -1,61 \cdot n \cdot a' = -1,61 \cdot 6,5 \cdot 2,25 = -23,54 \text{ kN}$$

$$W_4 = 0,34 \cdot n \cdot a' = 0,34 \cdot 6,5 \cdot 2,25 = 4,97 \text{ kN}$$

ZONA H:

$$W_1 = -0,92 \cdot n \cdot a' = -0,92 \cdot 6,5 \cdot 2,25 = -13,45 \text{ kN}$$

$$W_4 = 0,34 \cdot n \cdot a' = 0,34 \cdot 6,5 \cdot 2,25 = 4,94 \text{ kN}$$

ZONA I:

$$W_1 = -0,92 \cdot n \cdot a' = -0,92 \cdot 6,5 \cdot 2,25 = -13,45 \text{ kN}$$

$$W_4 = 0,34 \cdot n \cdot a' = 0,34 \cdot 6,5 \cdot 2,25 = 4,94 \text{ kN}$$

ZONA J:

$$W_1 = 0$$

$$W_4 = -0,34 \cdot n \cdot a' = -0,34 \cdot 6,5 \cdot 2,25 = 4,97 \text{ kN}$$

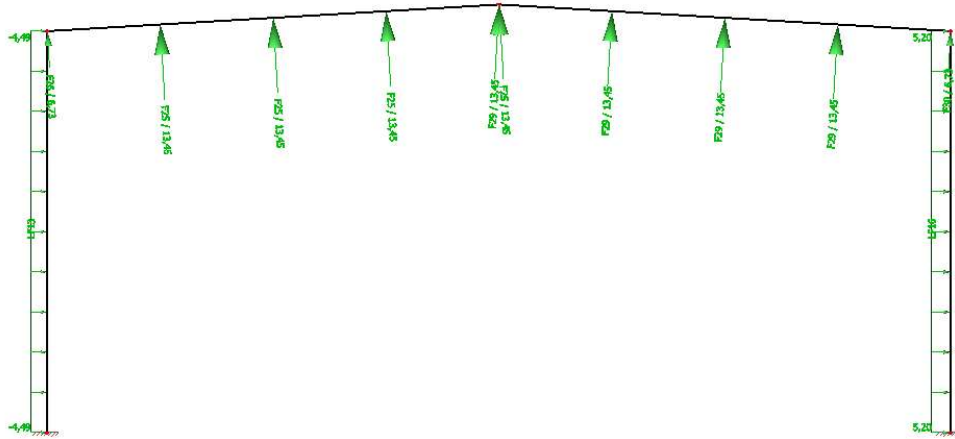

Slika 2.2.2 Opterećenja vjetra W_1 na konstrukciju

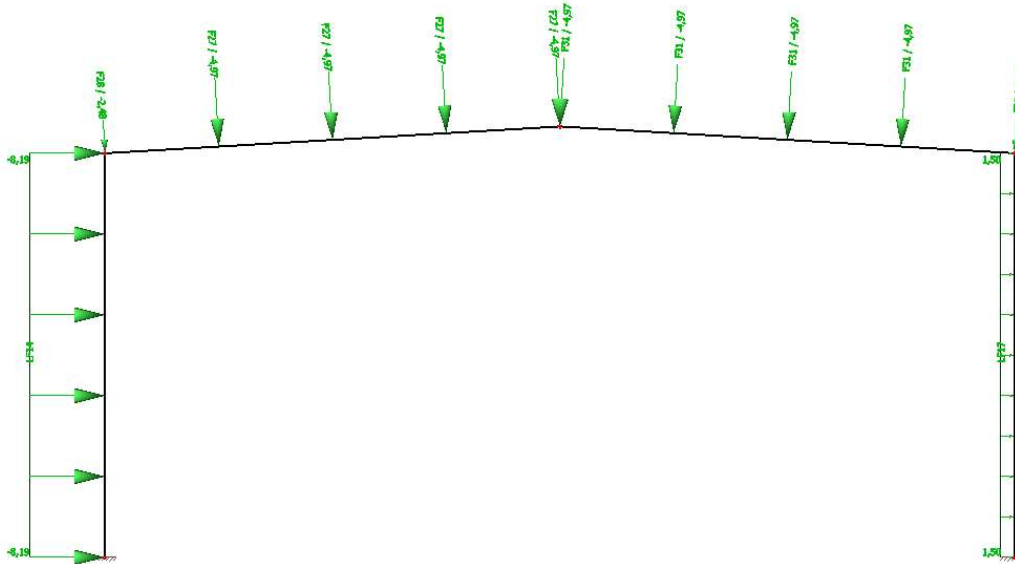

Slika 2.2.3 Opterećenje vjetra W_4 na konstrukciju

VJETAR NA ZABAT:

PODRUČJE	A	B	C	D
C_{pe1}	-1,2	-0,8	-0,5	0,8
W_{e1}	-1,38	-0,92	-0,57	0,92
W1 (W_{e1} "+" W_{i1})	-1,61	-0,69	-0,8	0,69
W2 (W_{e1} "+" W_{i2})	-1,04	-0,58	-0,23	1,26

$$\check{s}_a = \frac{1}{5}e = \frac{1}{5} \cdot 17,06 = 3,42 \text{ m}$$

$$\check{s}_b = \frac{4}{5}e = \frac{4}{5} \cdot 17,06 = 13,66 \text{ m}$$

$$\check{s}_c = L - e = 18,0 - 17,08 = 0,92 \text{ m}$$

ZONA A:

$$\Delta h = \frac{0,06 \cdot 3,42}{2} = 0,10 \text{ m}$$

$$W_A = \frac{H + h_1 + \Delta h}{4} \cdot x \cdot (-1,61) = \frac{8,10}{4} \cdot 2,25 \cdot (-1,61) = -7,34 \text{ kN}$$

ZONA B:

VISINA KONSTRUKCIJE U SLJEMENU – $H_{UK} = 8,54 \text{ m}$

$$W_B = \frac{H_{UK}}{4} \cdot x \cdot (-0,69) = \frac{8,54}{4} \cdot 2,25 \cdot (-0,69) = -3,32 \text{ kN}$$

ZONA C:

$$\Delta h = \frac{0,06 \cdot 0,94}{2} = 0,03 \text{ m}$$

$$W_C = \frac{H + h_1 + \Delta h}{4} \cdot \frac{x}{2} \cdot (-0,80) = \frac{8,03}{4} \cdot 2,25 \cdot (-0,80) = -3,61 \text{ kN}$$

ZONA D:

$$\Delta h = \frac{0,06 \cdot 9,0}{2} = 0,54 \text{ m}$$

$$W_D = \frac{H + h_1 + \Delta h}{4} \cdot x \cdot 1,26 = \frac{8,54}{4} \cdot 2,25 \cdot 1,26 = 5,86 \text{ kN}$$

VJETAR TRENJEM

$$2b = 2 \cdot 18 = 36 \text{ m}$$

$$4h = 4 \cdot 8,54 = 34,12 \text{ m}$$

$$c = \sqrt{9^2 + 0,54^2} = 9,02 \text{ m}$$

$$D = d - 4h = 65 - 34,12 = 30,84 \text{ m}$$

$$A_K = 2 \cdot 9,02 \cdot 30,84 = 556,36 \text{ m}^2$$

$$A_Z = (6,5 + 1,5) \cdot 30,84 = 246,72 \text{ m}^2$$

$$F_{fr} = c_{fr} \cdot q_p(z_e) \cdot A_{fr}$$

$$F_{fr,K} = 0,02 \cdot 1,148 \cdot 556,36 = 12,77 \text{ kN}$$

$$F_{fr,Z} = 0,02 \cdot 1,148 \cdot 246,72 = 5,66 \text{ kN}$$

NAJNEPOVOLJNIJI SLUČAJ

$$P_Z = W_D + \frac{F_{fr}}{2} = 5,86 + \frac{12,77}{2} = 12,25 \text{ kN}$$

$$P_{Z,RUB} = \frac{W_D}{4} + \frac{F_{tr,K}}{4} + \frac{F_{fr,Z}}{4} = \frac{5,86}{4} + \frac{12,77}{4} + \frac{5,66}{4} = 6,08 \text{ kN}$$

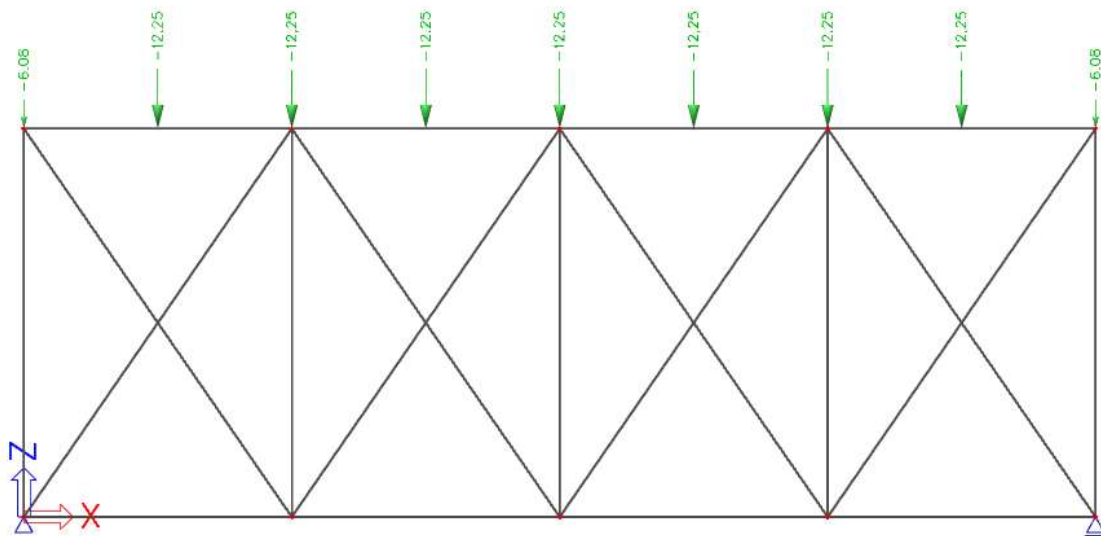

Slika 2.2.4 Opterećenje na krovni spreg od vjetra na zabat i trenja vjetra po površini krova

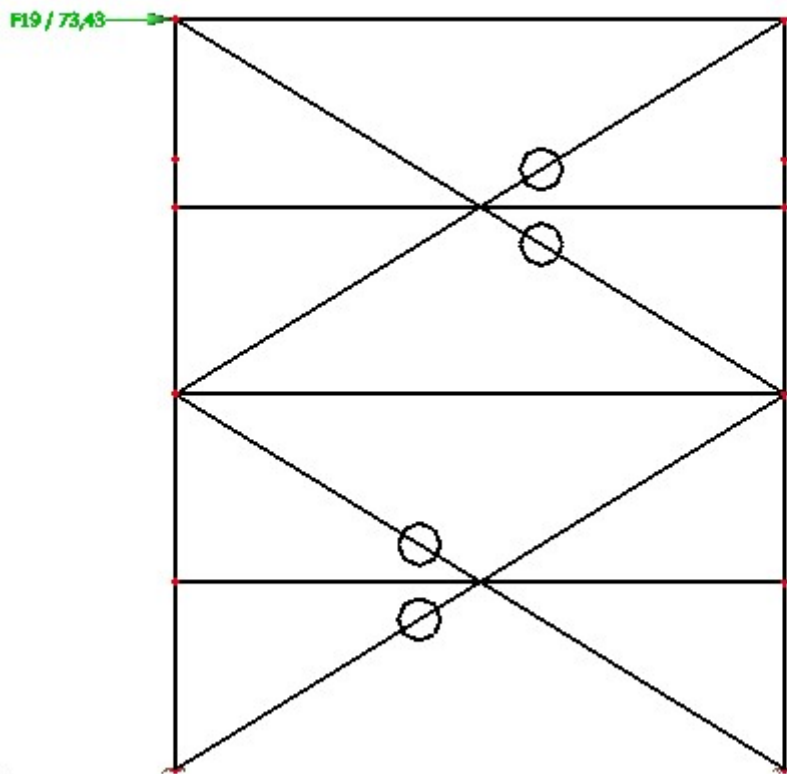

Slika 2.2.5 Opterećenje na bočni spreg od vjetra na zabat i trenja vjetra po površini krova

3. KONTROLA PROGIBA

GSU1 (1,0G+1,0G₁+1,0S) – PROGIB

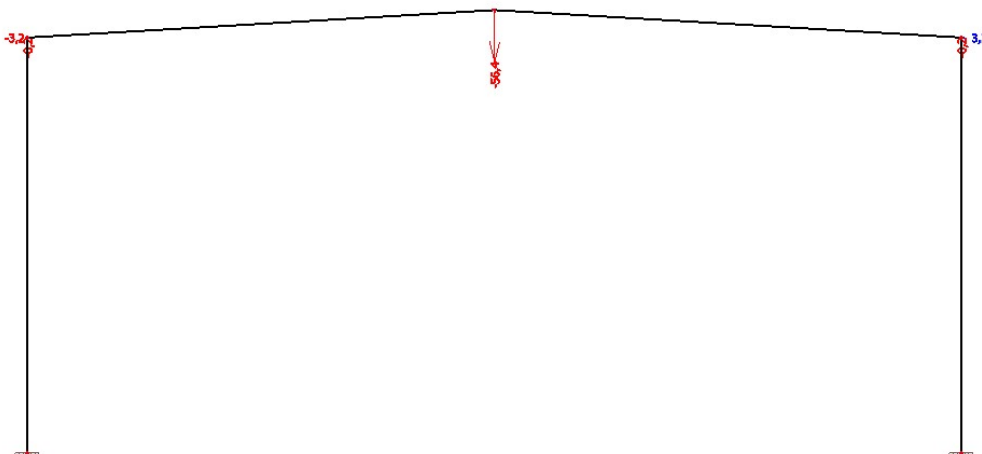

Slika 3.1.1 Vertikalni pomak rešetke

$$L/300 = 18000/300 = 60,0 \text{ mm} > 56,4 \text{ mm}$$

ISKORISTIVOST: 94 %

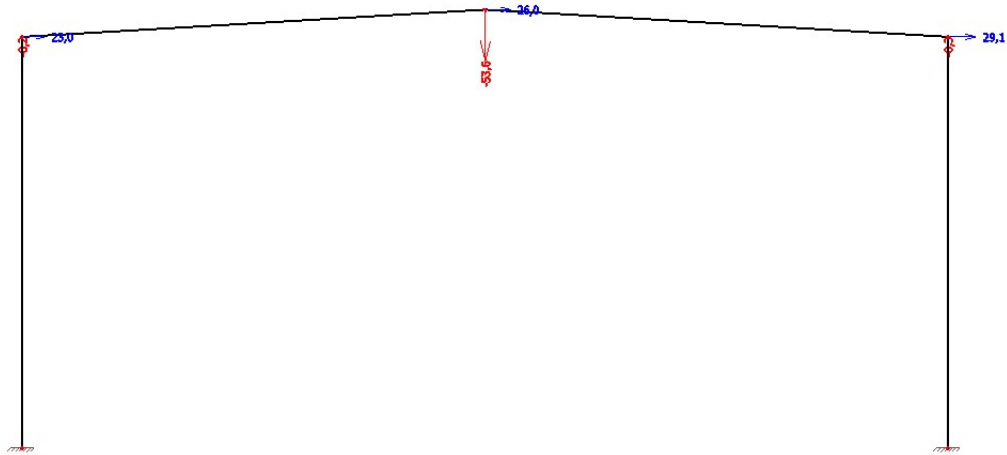
GSU2 (1,0G+1,0G₁+1,0W) – PROGIB

Slika 3.1.2 Horizontalni pomak rešetke

$L/300 = 8000/150 = 53,33 \text{ mm} > 29,1 \text{ mm}$
ISKORISTIVOST: 54,56 %

4. DIJAGRAMI REZNIH SILA

KOMBINACIJE ZA OKVIR:

GSN1 (1,35G+1,35G₁+1,5S)

GSN2 (1,35G+1,35G₁+1,5W₄)

GSN1 MOMENTNI DIJAGRAM (kNm)

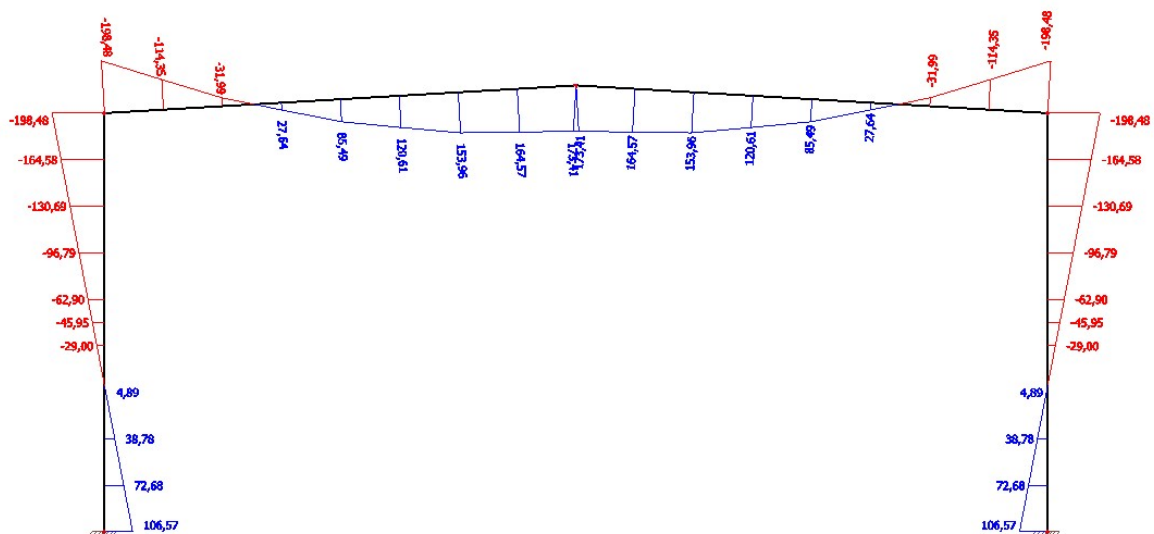

Slika 4.1.1 Momentni dijagram GSN1

DIJAGRAM POPREČNIH SILA (kN)

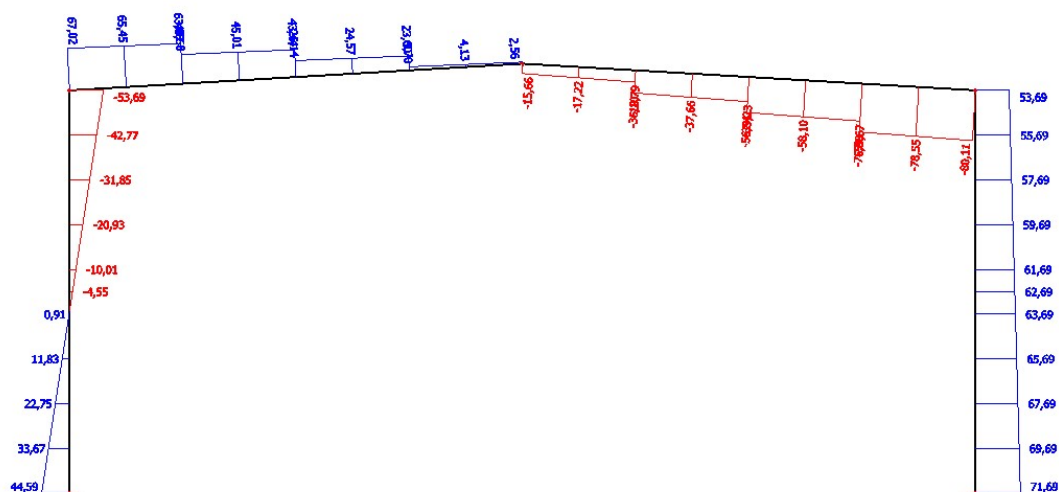

KOMBINACIJE ZA SPREG:

GSN(1,5 W) – Budući da je model izrađen zasebno i okomito na ravninu okvira jedine djelujuće sile su od vjetra na zabat

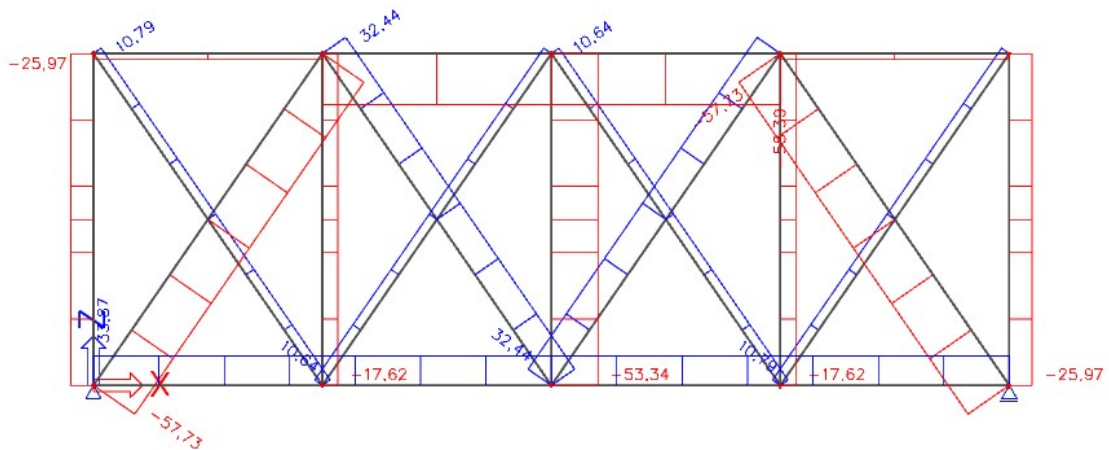
KROVNI SPREG
DIJAGRAM UZDUŽNIH SILA

Slika 4.3.1 Dijagram uzdužnih sila u krovnom spregu

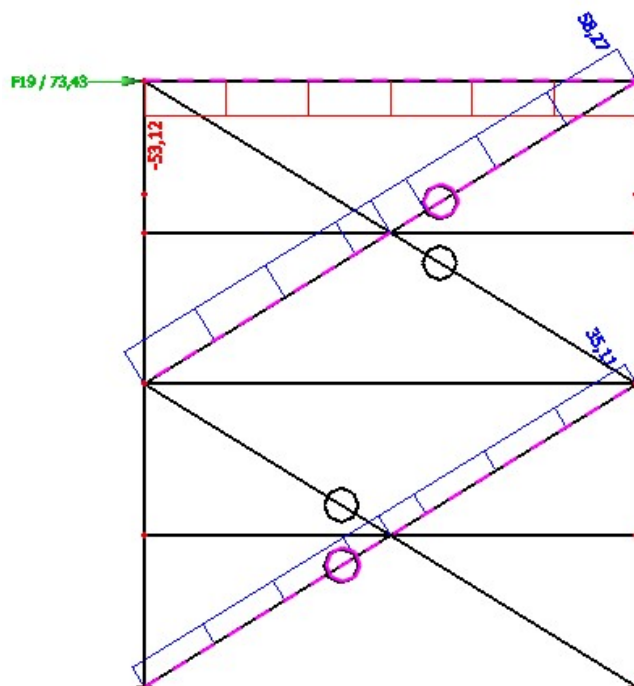
BOČNI SPREG
DIJAGRAM UZDUŽNIH SILA (kN)

Slika 4.4.1 Dijagram uzdužnih sila bočnog sprega

5. ODABRANI PRESJECI

Stup:	HEA 320
Greda:	HEA 340
Krovne podrožnice:	HEA 160A
Krovni spreg:	RD 14
Bočne podrožnice:	HEA 160A
Bočni spreg:	RD 18

6. DIMENZIONIRANJE

6.1 DIMENZIONIRANJE GLAVNE KONSTRUKCIJE

STUP HEA320

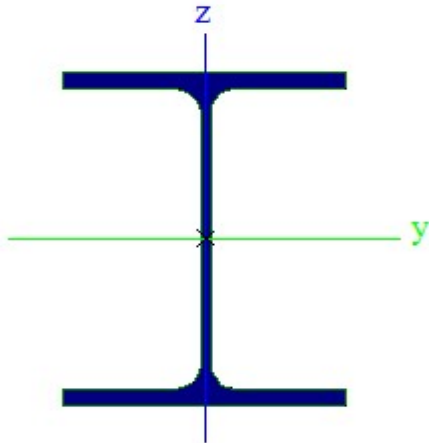

Profil:	HEA 320
Tip presjeka:	valjani
Visina presjeka:	$h = 310 \text{ mm}$
Širina presjeka:	$b = 300 \text{ mm}$
Debljina pojasnice:	$t_f = 16 \text{ mm}$
Debljina hrpta:	$t_w = 9 \text{ mm}$
Radius:	$r = 27 \text{ mm}$
Površina presjeka:	$A = 124 \text{ cm}^2$ $A_y = 89,52 \text{ cm}^2$ $A_z = 27,75 \text{ cm}^2$

Momenti otpora:	$I_y = 22900 \text{ cm}^4$ $I_z = 6990 \text{ cm}^4$
Momenti otpora:	$W_{PL,y} = 1629,2 \text{ cm}^3$ $W_{PL,z} = 708,33 \text{ cm}^3$
Konstanta krivljenja:	$I_w = 1512400 \text{ cm}^6$
Torzijska konstanta:	$I_t = 108 \text{ cm}^4$

Materijal: S235

$f_y = 235 \text{ MPa}$

$f_u = 360 \text{ Mpa}$

$E = 210 \text{ GPa} = 21000 \text{ kN/cm}^2$

$G = 8077 \text{ kN/cm}^2$

$\nu = 0,3$

KLASIFIKACIJA PRESJEKA HEA320

Ulazni podaci:

$$N_{Ed} = 137,48 \text{ kN (TLAK)}$$

$$M_{Ed} = 260,43 \text{ kNm}$$

$$V_{Ed} = 71,69 \text{ kN}$$

HRBAT (IZLOŽEN TLAKU I SAVIJANJU)

$$c = h - 2r - 2t_f = 310 - (2 \cdot 27) - (2 \cdot 16) = 224 \text{ mm}$$

$$\frac{c}{t_w} \leq \frac{224}{9} = 24,89$$

$$a = \frac{N_{Ed}}{2 \cdot t_w \cdot f_y / \gamma_{M0}} = \frac{137,74}{2 \cdot 0,9 \cdot 23,5 / 1,0} = 3,25 \text{ cm}$$

$$\alpha = \frac{1}{c} \left(\frac{c}{2} + a \right) = \frac{1}{22,4} \left(\frac{22,4}{2} + 3,25 \right) = 0,645 > 0,5$$

$$\frac{c}{t_w} \leq \frac{396\varepsilon}{13\alpha - 1}$$

$$\frac{c}{t_w} \leq \frac{396\varepsilon}{13\alpha - 1}$$

$$24,89 \leq \frac{396 \cdot 1,0}{13 \cdot 0,645 - 1} = 53,62$$

HRBAT KLASA 1

POJASNICA (IZLOŽENA TLAKU)

$$c = \frac{b - t_w - 2r}{2} = \frac{300 - 9 - 2 \cdot 27}{2} = 118,5 \text{ mm}$$

$$\frac{c}{t_f} \leq 9\varepsilon$$

$$\frac{118,5}{16} \leq 9 \cdot 1,0$$

$$7,41 < 9,0$$

POJASNICA KLASA 1

POPREČNI PRESJEK KLASA 1

OTPORNOST POPREČNOG PRESJEKA

- NA UZDUŽNU SILU

$$N_{Rd} = \frac{A \cdot f_y}{\gamma_{M0}} = \frac{124 \cdot 23,5}{1,0} = 2914 \text{ kN} > N_{Ed} = 137,48 \text{ kN}$$

- NA MOMENT SAVIJANJA

$$M_{c,Rd} = M_{PL,Rd} = \frac{W_{PL} \cdot f_y}{\gamma_{M0}} = \frac{1629,2 \cdot 23,5}{1,0} = 38286,2 \text{ kNcm} = 382,9 \text{ kN}$$

$$M_{c,Rd} = 382,9 \text{ kNm} > M_{MAX} = 260,43 \text{ kNm}$$

- NA POPREČNU SILU

$$c = h - 2r - 2t_f = 310 - (2 \cdot 27) - (2 \cdot 16) = 224 \text{ mm}$$

$$\frac{c}{t_w} \leq 72 \frac{\varepsilon}{\eta}$$

$$\frac{224}{9} \leq 72 \cdot \frac{1,0}{1,2}$$

$$24,89 < 60$$

NIJE POTREBNA KONTROLA IZBOČAVANJA HRPTA

$$A_z = A - 2b \cdot t_f + (t_w + 2r) \cdot t_f \geq \eta \cdot h_w \cdot t_w$$

$$A_z = 124 - 2 \cdot 30 \cdot 1,6 + (0,9 + 2 \cdot 2,7) \cdot 1,6 \geq 1,2 \cdot 26,8 \cdot 0,9$$

$$A_z = 38,8 > 28,94$$

$$V_{PL,Rd} = \frac{A_z \cdot f_y}{\sqrt{3} \cdot \gamma_{M0}} = \frac{38,8 \cdot 23,5}{\sqrt{3} \cdot 1,0} = 526,43 \text{ kN} > V_{Ed} = 71,95 \text{ kN}$$

$$V_{Ed} < 0,5V_{PL,Rd}$$

$$71,95 \text{ kN} < 263,22 \text{ kN}$$

NISKA RAZINA POPREČNE SILE, NIJE POTREBNA REDUKCIJA

UZDUŽNA TLAČNA OTPORNOST ELEMENTA

$$N_{CR} = \frac{\pi^2 \cdot EI}{L_{CR}^2}$$

$$\bar{\lambda} = \sqrt{\frac{A \cdot f_y}{N_{CR}}}$$

$$\Phi = 0,5[1 + \alpha(\bar{\lambda} - 0,2) + \bar{\lambda}^2]$$

$$\chi = \frac{1}{\Phi + \sqrt{\Phi^2 + \bar{\lambda}^2}}$$

$$N_{b,Rd} = \frac{\chi \cdot A \cdot f_y}{\gamma_{M1}}$$

y-y

$$N_{Sd} = 137,48 \text{ kN}$$

$$A = 124 \text{ cm}^2$$

$$N_{Pl,Rd} = 2914,00 \text{ kN}$$

$$I = 22900 \text{ cm}^4$$

$$N_{CR} = 29664,33 \text{ kN}$$

$$L_{CR} = 400 \text{ cm}$$

$$\lambda = 0,313$$

$$f_y = 235 \text{ N/mm}^2$$

$$\Phi = 0,561$$

$$\alpha = 0,21$$

$$\chi = 0,974$$

z-z

$$N_{Sd} = 137,48 \text{ kN}$$

$$A = 124 \text{ cm}^2$$

$$N_{Pl,Rd} = 2914,00 \text{ kN}$$

$$I = 6990 \text{ cm}^4$$

$$N_{CR} = 2263,69 \text{ kN}$$

$$L_{CR} = 800 \text{ cm}$$

$$\lambda = 1,135$$

$$f_y = 235 \text{ N/mm}^2$$

$$\Phi = 1,242$$

$$\alpha = 0,21$$

$$\chi = 0,573$$

$$N_{b,Rd} = 1668,51 \text{ kN}$$

OTPORNOST ELEMENTA NA SAVIJANJE

$$M_{CR} = C_1 \cdot \frac{\pi^2 \cdot E \cdot I_z}{|k \cdot L|^2} \left[\sqrt{\left(\frac{k}{k_w}\right)^2 \cdot \frac{I_w}{I_z} + \frac{|k \cdot L|^2 \cdot G \cdot I_t}{\pi^2 \cdot E \cdot I_z} + |C_2 \cdot z_g|^2} - C_2 \cdot z_g \right]$$

$$z_g = 155 \text{ mm} = 15,5 \text{ cm}$$

$$L = 800,0 \text{ cm}$$

$$C_1 = 2,55$$

$$C_2 = 0$$

$$k = 0,5$$

$$k_w = 0,5$$

$$M_{CR} = 2,55 \cdot \frac{\pi^2 \cdot 21000 \cdot 6990}{(0,5 \cdot 800)^2} \left[\sqrt{\left(\frac{0,5}{0,5}\right)^2 \cdot \frac{1512400}{6990} + \frac{(0,5 \cdot 800)^2 \cdot 8077 \cdot 108}{\pi^2 \cdot 21000 \cdot 6990} + 0 - 0} \right]$$

$$M_{CR} = 408303,7 \text{ kNcm} = 4083,04 \text{ kNm}$$

$$\bar{\lambda}_{LT} = \sqrt{\frac{W_y \cdot f_y}{M_{CR}}} = \sqrt{\frac{1629,2 \cdot 23,5}{408303,7}} = 0,306 < 0,4$$

$$h/b = 310/300 = 1,033$$

$$\text{IZVIJANJE OKO OSI } y-y, \alpha_{LT} = 0,21$$

$$\Phi_{LT} = 0,5 \left[1 + \alpha_{LT}(\bar{\lambda}_{LT} - 0,2) + \bar{\lambda}_{LT}^2 \right] = 0,5[1 + 0,21(0,306 - 0,2) + 0,306^2] = 0,558$$

$$\chi_{LT} = \frac{1}{\Phi_{LT} + \sqrt{\Phi_{LT}^2 - \bar{\lambda}_{LT}^2}} = \frac{1}{0,558 + \sqrt{0,558^2 - 0,306^2}} = 0,976$$

$$M_{b,Rd} = \chi_{LT} \cdot \frac{W_y \cdot f_y}{\gamma_{M1}} = 0,976 \cdot \frac{1629,2 \cdot 23,5}{1,0} = 37368,7 \text{ kNcm} = 373,69 \text{ kNm} > M_{Ed}$$

$$= 260,43 \text{ kNm}$$

ISKORISTIVOST:

$$\eta = 69,69\%$$

INTERAKCIJA M-N

$$\frac{N_{Ed}}{\chi_y \cdot N_{Rk}/\gamma_{M1}} + k_{yy} \cdot \frac{M_{y,Ed}}{\chi_{LT} \cdot M_{y,Rk}/\gamma_{M1}} \leq 1,0$$

$$\frac{N_{Ed}}{\chi_z \cdot N_{Rk}/\gamma_{M1}} + k_{zy} \cdot \frac{M_{y,Ed}}{\chi_{LT} \cdot M_{y,Rk}/\gamma_{M1}} \leq 1,0$$

$$\Psi = -0,925$$

$$a_h = \frac{M_s}{M_h} = \frac{27,7}{260,43} = 0,106$$

$$C_{my}, C_{mz}, C_{mLT} = 0,2 + 0,8 a_h \geq 0,4$$

$$0,2 + 0,8 \cdot 0,106 \geq 0,4$$

$$0,284 < 0,4$$

$$C_{my}, C_{mLT} = 0,4$$

$$k_{yy} = C_{my} \left(1 + (\bar{\lambda}_y - 0,2) \cdot \frac{N_{Ed}}{\chi_y \cdot N_{Rk}/\gamma_{M1}} \right) \leq C_{my} \left(1 + 0,8 \cdot \frac{N_{Ed}}{\chi_y \cdot N_{Rk}/\gamma_{M1}} \right)$$

$$k_{zy} = \left(1 - \frac{0,1 \cdot \bar{\lambda}_z}{C_{mLT} - 0,25} \cdot \frac{N_{Ed}}{\chi_z \cdot N_{Rk}/\gamma_{M1}} \right) \leq \left(1 - \frac{0,1}{C_{mLT} - 0,25} \cdot \frac{N_{Ed}}{\chi_z \cdot N_{Rk}/\gamma_{M1}} \right)$$

$$k_{yy} = 0,4 \left(1 + (0,313 - 0,2) \cdot \frac{137,48}{0,974 \cdot 2914/1,0} \right) \leq 0,4 \left(1 + 0,8 \cdot \frac{137,48}{0,974 \cdot 2914/1,0} \right)$$

$$k_{yy} = 0,402 \leq 0,416$$

$$k_{zy} = \left(1 - \frac{0,1 \cdot 1,134}{0,4 - 0,25} \cdot \frac{137,48}{0,572 \cdot 2914/1,0} \right) \leq \left(1 - \frac{0,1}{0,4 - 0,25} \cdot \frac{137,48}{0,572 \cdot 2914/1,0} \right)$$

$$k_{zy} = 0,938 \leq 0,945$$

$$\frac{137,48}{0,974 \cdot 2914/1,0} + 0,402 \cdot \frac{260,43}{0,976 \cdot 382,86/1,0} \leq 1,0$$

$$0,328 < 1,0$$

$$\frac{137,48}{0,572 \cdot 2914/1,0} + 0,938 \cdot \frac{260,43}{0,976 \cdot 382,86/1,0} \leq 1,0$$

$$0,736 < 1,0$$

ISKORISTIVOST:

$$\eta = 73,6\%$$

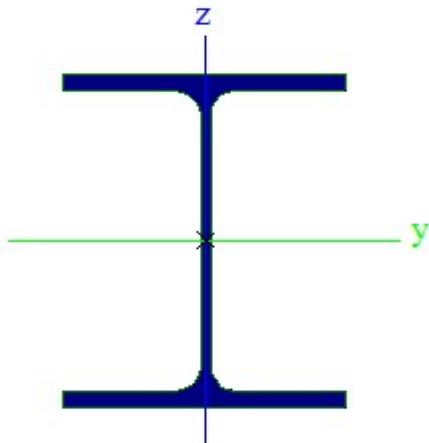
GREDA HEA340

Profil: HEA 340
Tip presjeka: valjani
Visina presjeka: $h = 330 \text{ mm}$
Širina presjeka: $b = 300 \text{ mm}$
Debljina pojasnice: $t_f = 17 \text{ mm}$
Debljina hrpta: $t_w = 10 \text{ mm}$
Radius: $r = 27 \text{ mm}$
Površina presjeka: $A = 134 \text{ cm}^2$
 $A_y = 95,5 \text{ cm}^2$
 $A_z = 33,2 \text{ cm}^2$

Momenti otpora: $I_y = 27700 \text{ cm}^4$
 $I_z = 7440 \text{ cm}^4$
Momenti otpora: $W_{PL,y} = 1850 \text{ cm}^3$
 $W_{PL,z} = 754,17 \text{ cm}^3$
Konstanta krivljenja: $I_w = 1824400 \text{ cm}^6$
Torzijska konstanta: $I_t = 127 \text{ cm}^4$

Materijal: S235
 $f_y = 235 \text{ MPa}$
 $f_u = 360 \text{ Mpa}$
 $E = 210 \text{ GPa} = 21000 \text{ kN/cm}^2$
 $G = 8077 \text{ kN/cm}^2$
 $\nu = 0,3$

KLASIFIKACIJA PRESJEKA HEA320

Ulazni podaci:

$$N_{Ed} = 58,72 \text{ kN (TLAK)}$$

$$M_{Ed} = 260,43 \text{ kNm}$$

$$V_{Ed} = 80,11 \text{ kN}$$

HRBAT (IZLOŽEN TLAKU I SAVIJANJU)

$$c = h - 2r - 2t_f = 330 - (2 \cdot 27) - (2 \cdot 17) = 242 \text{ mm}$$

$$\frac{c}{t_w} \leq \frac{242}{10} = 24,2$$

$$a = \frac{N_{Ed}}{2 \cdot t_w \cdot f_y / \gamma_{M0}} = \frac{58,72}{2 \cdot 1,0 \cdot 23,5 / 1,0} = 1,25 \text{ cm}$$

$$\alpha = \frac{1}{c} \left(\frac{c}{2} + a \right) = \frac{1}{24,2} \left(\frac{24,2}{2} + 1,25 \right) = 0,551 > 0,5$$

$$\frac{c}{t_w} \leq \frac{396\varepsilon}{13\alpha - 1}$$

$$\frac{c}{t_w} \leq \frac{396\varepsilon}{13\alpha - 1}$$

$$24,2 \leq \frac{396 \cdot 1,0}{13 \cdot 0,551 - 1} = 55,28$$

HRBAT KLASA 1

POJASNICA (IZLOŽENA TLAKU)

$$c = \frac{b - t_w - 2r}{2} = \frac{300 - 10 - 2 \cdot 27}{2} = 118 \text{ mm}$$

$$\frac{c}{t_f} \leq 9\varepsilon$$

$$\frac{118}{17} \leq 9 \cdot 1,0$$

$$6,94 < 9,0$$

POJASNICA KLASA 1

POPREČNI PRESJEK KLASA 1

OTPORNOST POPREČNOG PRESJEKA

- NA UZDUŽNU SILU

$$N_{Rd} = \frac{A \cdot f_y}{\gamma_{M0}} = \frac{134 \cdot 23,5}{1,0} = 3149 \text{ kN} > N_{Ed} = 58,72 \text{ kN}$$

- NA MOMENT SAVIJANJA

$$M_{c,Rd} = M_{PL,Rd} = \frac{W_{PL} \cdot f_y}{\gamma_{M0}} = \frac{1850 \cdot 23,5}{1,0} = 43475 \text{ kNcm} = 434,75 \text{ kN}$$

$$M_{c,Rd} = 434,75 \text{ kNm} > M_{MAX} = 260,43 \text{ kNm}$$

- NA POPREČNU SILU

$$c = h - 2r - 2t_f = 330 - (2 \cdot 27) - (2 \cdot 17) = 242 \text{ mm}$$

$$\frac{c}{t_w} \leq 72 \frac{\varepsilon}{\eta}$$

$$\frac{242}{10} \leq 72 \cdot \frac{1,0}{1,2}$$

$$24,2 < 60$$

NIJE POTREBNA KONTROLA IZBOČAVANJA HRPTA

$$A_z = A - 2b \cdot t_f + (t_w + 2r) \cdot t_f \geq \eta \cdot h_w \cdot t_w$$

$$A_z = 134 - 2 \cdot 30 \cdot 1,7 + (1,0 + 2 \cdot 2,7) \cdot 1,7 \geq 1,2 \cdot 26,6 \cdot 1,0$$

$$A_z = 42,88 > 31,92$$

$$V_{PL,Rd} = \frac{A_z \cdot f_y}{\sqrt{3} \cdot \gamma_{M0}} = \frac{42,88 \cdot 23,5}{\sqrt{3} \cdot 1,0} = 581,78 \text{ kN} > V_{Ed} = 80,11 \text{ kN}$$

$$V_{Ed} < 0,5V_{PL,Rd}$$

$$80,11 \text{ kN} < 290,89 \text{ kN}$$

NISKA RAZINA POPREČNE SILE, NIJE POTREBNA REDUKCIJA

UZDUŽNA TLAČNA OTPORNOST ELEMENTA

$$N_{CR} = \frac{\pi^2 \cdot EI}{L_{CR}^2}$$

$$\bar{\lambda} = \sqrt{\frac{A \cdot f_y}{N_{CR}}}$$

$$\Phi = 0,5[1 + \alpha(\bar{\lambda} - 0,2) + \bar{\lambda}^2]$$

$$\chi = \frac{1}{\Phi + \sqrt{\Phi^2 + \bar{\lambda}^2}}$$

$$N_{b,Rd} = \frac{\chi \cdot A \cdot f_y}{\gamma_{M1}}$$

y-y

$$N_{Sd} = 58,72 \text{ kN}$$

$$A = 134 \text{ cm}^2$$

$$N_{Pl,Rd} = 3149,00 \text{ kN}$$

$$I = 27700 \text{ cm}^4$$

$$N_{CR} = 113003,26 \text{ kN}$$

$$L_{CR} = 225,4 \text{ cm}$$

$$\lambda = 0,170$$

$$f_y = 235 \text{ N/mm}^2$$

$$\Phi = 0,510$$

$$\alpha = 0,21$$

$$\chi = 1,007$$

z-z

$$N_{Sd} = 58,72 \text{ kN}$$

$$A = 134 \text{ cm}^2$$

$$N_{Pl,Rd} = 3149,00 \text{ kN}$$

$$I = 7440 \text{ cm}^4$$

$$N_{CR} = 1896,99 \text{ kN}$$

$$L_{CR} = 901,6 \text{ cm}$$

$$\lambda = 1,288$$

$$f_y = 235 \text{ N/mm}^2$$

$$\Phi = 1,444$$

$$\alpha = 0,21$$

$$\chi = 0,477$$

$$N_{b,Rd} = 1501,72 \text{ kN}$$

OTPORNOST ELEMENTA NA SAVIJANJE

$$M_{CR} = C_1 \cdot \frac{\pi^2 \cdot E \cdot I_z}{|k \cdot L|^2} \left[\sqrt{\left(\frac{k}{k_w}\right)^2 \cdot \frac{I_w}{I_z} + \frac{|k \cdot L|^2 \cdot G \cdot I_t}{\pi^2 \cdot E \cdot I_z} + |C_2 \cdot z_g|^2} - C_2 \cdot z_g \right]$$

$$z_g = 155 \text{ mm} = 16,5 \text{ cm}$$

$$L = 901,6 \text{ cm}$$

$$C_1 = 2,55$$

$$C_2 = 0$$

$$k = 1,0$$

$$k_w = 1,0$$

$$M_{CR} = 2,55 \cdot \frac{\pi^2 \cdot 21000 \cdot 7440}{(1,0 \cdot 901,6)^2} \left[\sqrt{\left(\frac{1,0}{1,0}\right)^2 \cdot \frac{1824400}{7440} + \frac{(1,0 \cdot 901,6)^2 \cdot 8077 \cdot 127}{\pi^2 \cdot 21000 \cdot 7440} + 0 - 0} \right]$$

$$M_{CR} = 136677,3 \text{ kNcm} = 1366,77 \text{ kNm}$$

$$\bar{\lambda}_{LT} = \sqrt{\frac{W_y \cdot f_y}{M_{CR}}} = \sqrt{\frac{1850 \cdot 23,5}{136677,3}} = 0,564 > 0,4$$

$$h/b = 330/300 = 1,100$$

$$\text{IZVIJANJE OKO OSI } y-y, \alpha_{LT} = 0,21$$

$$\Phi_{LT} = 0,5 \left[1 + \alpha_{LT}(\bar{\lambda}_{LT} - 0,2) + \bar{\lambda}_{LT}^2 \right] = 0,5[1 + 0,21(0,564 - 0,2) + 0,564^2] = 0,697$$

$$\chi_{LT} = \frac{1}{\Phi_{LT} + \sqrt{\Phi_{LT}^2 - \bar{\lambda}_{LT}^2}} = \frac{1}{0,697 + \sqrt{0,697^2 - 0,564^2}} = 0,903$$

$$M_{b,Rd} = \chi_{LT} \cdot \frac{W_y \cdot f_y}{\gamma_{M1}} = 0,903 \cdot \frac{1850 \cdot 23,5}{1,0} = 39264,03 \text{ kNcm} = 392,64 \text{ kNm} > M_{Ed}$$

$$= 260,43 \text{ kNm}$$

ISKORISTIVOST:

$$\eta = 66,33\%$$

INTERAKCIJA M-N

$$\frac{N_{Ed}}{\chi_y \cdot N_{Rk}/\gamma_{M1}} + k_{yy} \cdot \frac{M_{y,Ed}}{\chi_{LT} \cdot M_{y,Rk}/\gamma_{M1}} \leq 1,0$$

$$\frac{N_{Ed}}{\chi_z \cdot N_{Rk}/\gamma_{M1}} + k_{zy} \cdot \frac{M_{y,Ed}}{\chi_{LT} \cdot M_{y,Rk}/\gamma_{M1}} \leq 1,0$$

$$\Psi = -0,66$$

$$a_h = \frac{M_s}{M_h} = \frac{47,56}{-260,43} = -0,183$$

$$C_{my}, C_{mz}, C_{mLT} = 0,2 \cdot (-\Psi) - 0,8 a_h \geq 0,4$$

$$0,2 \cdot 0,66 + 0,8 \cdot 0,183 \geq 0,4$$

$$0,278 < 0,4$$

$$C_{my}, C_{mLT} = 0,4$$

$$k_{yy} = C_{my} \left(1 + (\bar{\lambda}_y - 0,2) \cdot \frac{N_{Ed}}{\chi_y \cdot N_{Rk}/\gamma_{M1}} \right) \leq C_{my} \left(1 + 0,8 \cdot \frac{N_{Ed}}{\chi_y \cdot N_{Rk}/\gamma_{M1}} \right)$$

$$k_{zy} = \left(1 - \frac{0,1 \cdot \bar{\lambda}_z}{C_{mLT} - 0,25} \cdot \frac{N_{Ed}}{\chi_z \cdot N_{Rk}/\gamma_{M1}} \right) \leq \left(1 - \frac{0,1}{C_{mLT} - 0,25} \cdot \frac{N_{Ed}}{\chi_z \cdot N_{Rk}/\gamma_{M1}} \right)$$

$$k_{yy} = 0,4 \left(1 + (0,170 - 0,2) \cdot \frac{58,72}{1,007 \cdot 3149/1,0} \right) \leq 0,4 \left(1 + 0,8 \cdot \frac{58,72}{1,007 \cdot 3149/1,0} \right)$$

$$k_{yy} = 0,400 \leq 0,406$$

$$k_{zy} = \left(1 - \frac{0,1 \cdot 1,288}{0,4 - 0,25} \cdot \frac{58,72}{0,476 \cdot 3149/1,0} \right) \leq \left(1 - \frac{0,1}{0,4 - 0,25} \cdot \frac{58,72}{0,476 \cdot 3149/1,0} \right)$$

$$k_{zy} = 0,966 \leq 0,974$$

$$\frac{58,72}{1,007 \cdot 3149/1,0} + 0,4 \cdot \frac{260,43}{0,903 \cdot 434,75/1,0} \leq 1,0$$

$$0,284 < 1,0$$

$$\frac{58,72}{0,476 \cdot 3149/1,0} + 0,966 \cdot \frac{260,43}{0,903 \cdot 434,75/1,0} \leq 1,0$$

$$0,680 < 1,0$$

ISKORISTIVOST:

$$\eta = 68,00 \%$$

6.2 DIMENZIONIRANJE SEKUNDARNE KONSTRUKCIJE

KROVNA PODROŽNICA

$$\alpha = 6\% \rightarrow \operatorname{tg}^{-1}(0,06) = 3,4336^\circ = 3^\circ 26' 07''$$

STALNO OPTEREĆENJE:

$$\Delta g = 0,50 \text{ kN/m}^2 \text{ (sekundarna konst.+paneli+instalacije)}$$

$$G = \Delta g \cdot x = 0,5 \cdot 2,25 = 1,125 \text{ kN/m}$$

$$G_y = G \cdot \sin \alpha = 1,125 \cdot \sin 3^\circ 26' 07'' = 0,07 \text{ kN/m}$$

$$G_z = G \cdot \cos \alpha = 1,125 \cdot \cos 3^\circ 26' 07'' = 1,12 \text{ kN/m}$$

OPTEREĆENJE SNIJEGOM:

$$S = s_k \cdot x' = 0,4 \cdot 2,25 = 0,9 \text{ kN/m}$$

$$S_y = S \cdot \sin \alpha = 0,9 \cdot \sin 3^\circ 26' 07'' = 0,05 \text{ kN/m}$$

$$S_z = S \cdot \cos \alpha = 0,9 \cdot \cos 3^\circ 26' 07'' = 0,89 \text{ kN/m}$$

OPTEREĆENJE VJETROM:

ZONA G:

$$W_1 = -1,61 \cdot x' = -1,61 \cdot 2,254 = -3,63 \text{ kN/m}$$

$$W_4 = 0,34 \cdot x' = 0,34 \cdot 2,254 = 0,77 \text{ kN/m}$$

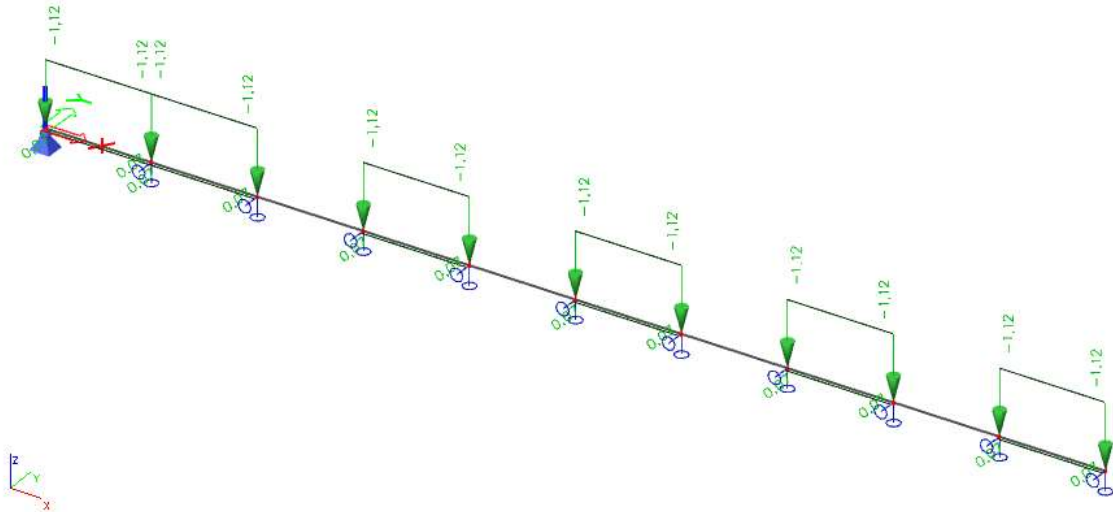

Slika 6.2.1 Stalno opterećenje na krovnu podrožnicu

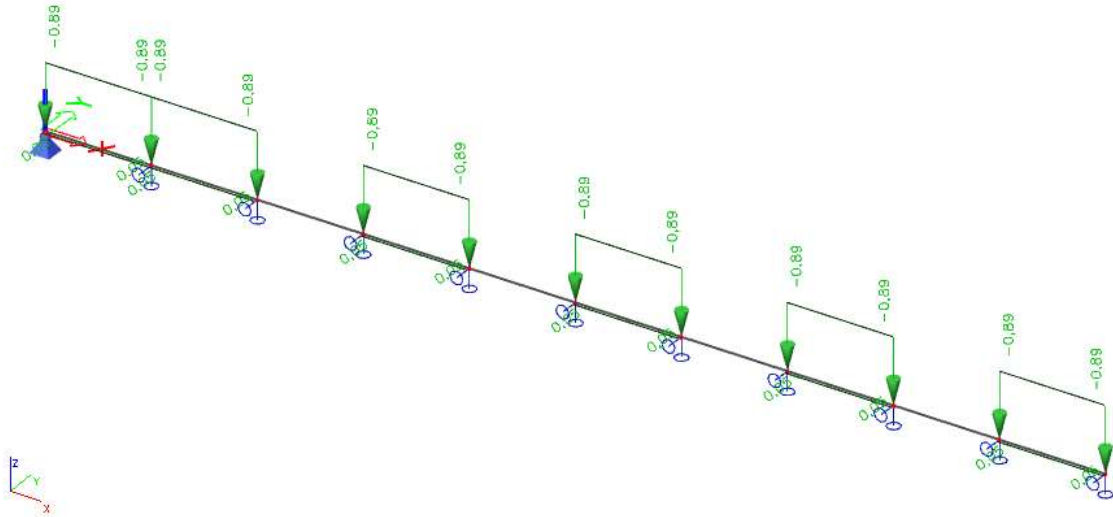

Slika6.2.2 Opterećenje snijega na krovnu podrožnicu

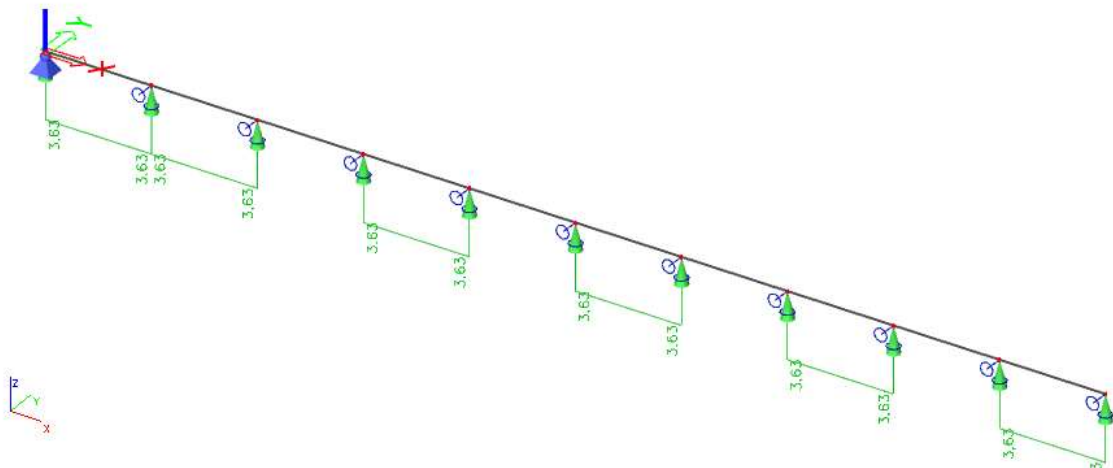

Slika6.2.3 Opterećenje vjeta na krovnu podrožnicu

DIJAGRAMI REZNIH SILA NA KROVNU PODROŽNICU

KOMBINACIJA 1 (1,35G + 1,5S)

DIJAGRAMI POPREČNIH SILA (kN)

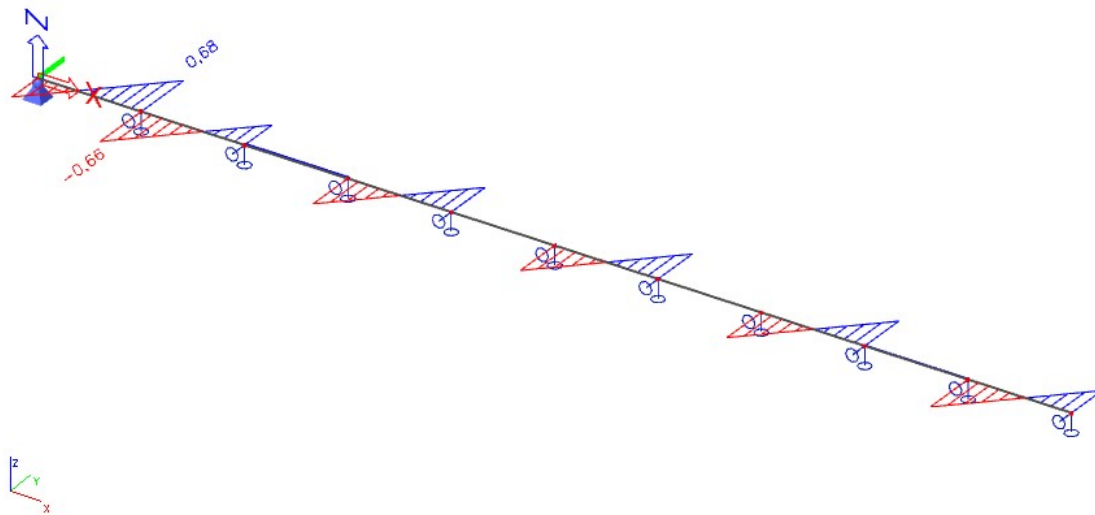

Slika 6.2.4 Dijagram poprečnih sila na krovnoj podrožnici (os y-y)

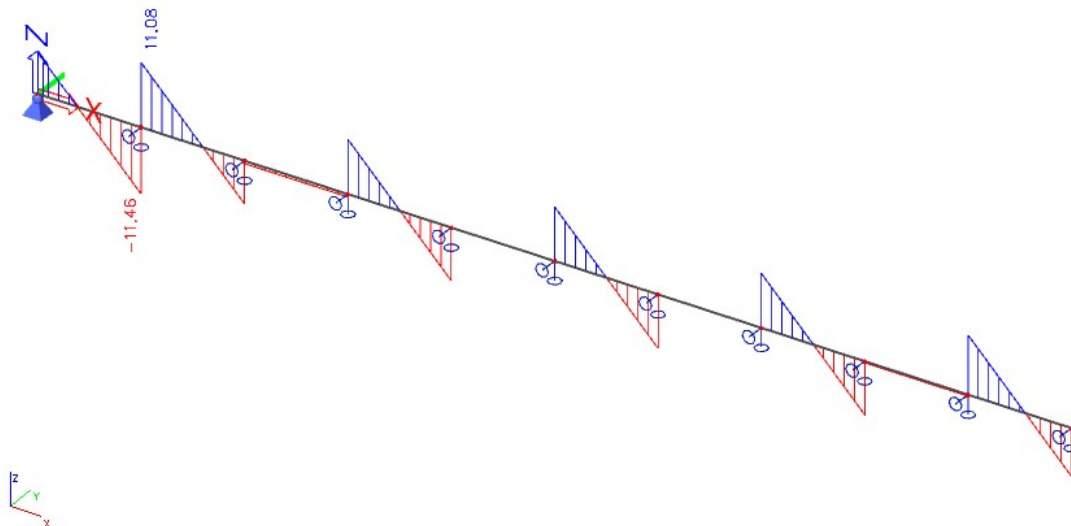

Slika 6.2.5 Dijagram poprečnih sila na krovnoj podrožnici (os z-z)

MOMENTNI DIJAGRAMI (kNm)

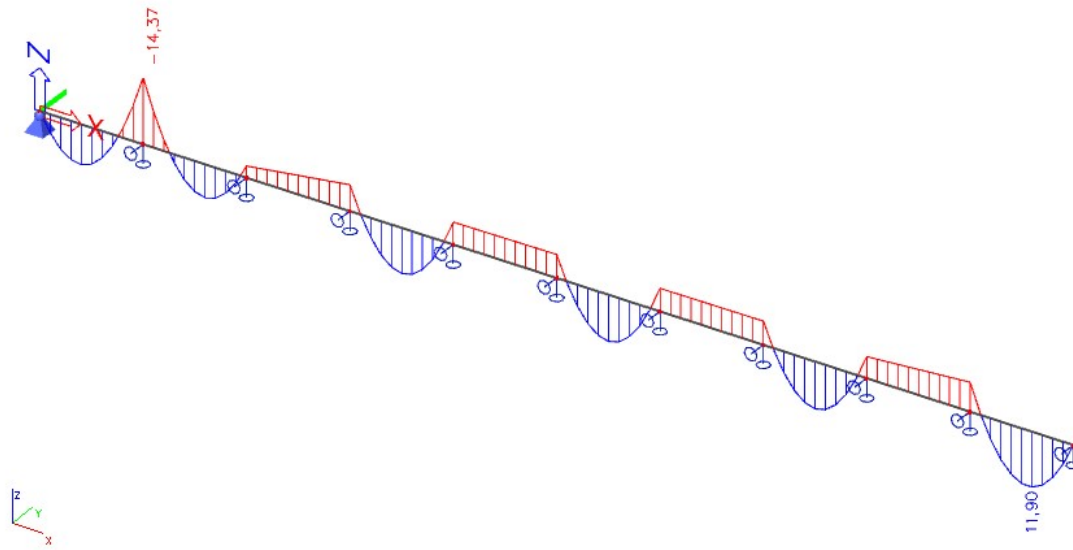

Slika 6.2.6 Momentni dijagram na krovnoj podrožnici (os y-y)

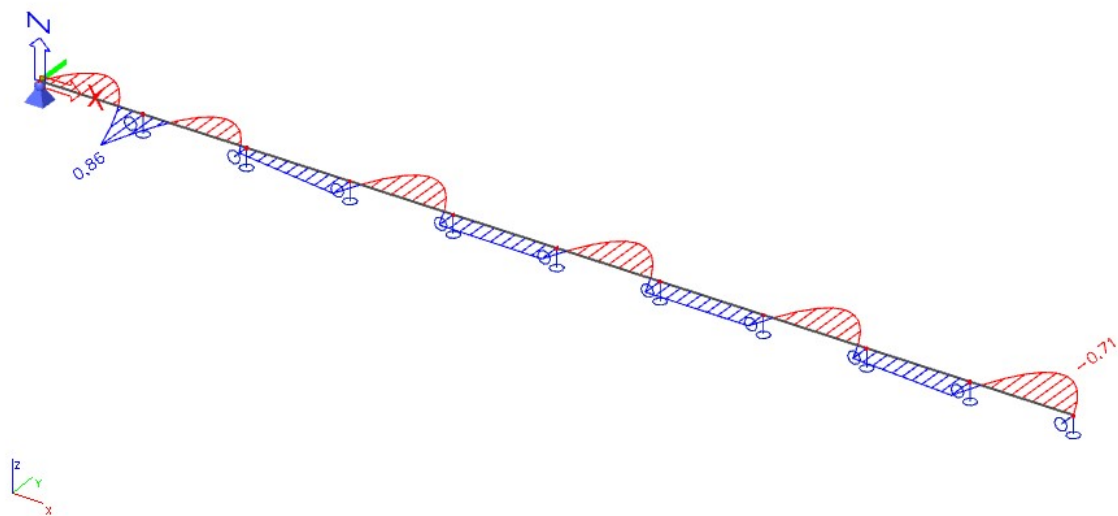

Slika 6.2.7 Momentni dijagram na krovnoj podrožnici (os z-z)

KOMBINACIJA 2 (1,0G + 1,5w)

DIJAGRAMI POPREČNIH SILA (kN)

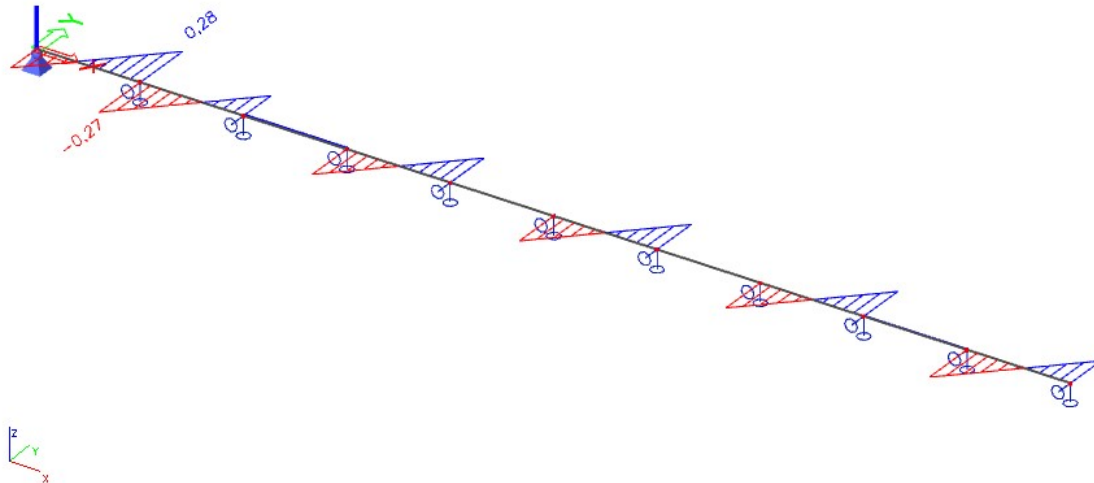

Slika 6.2.8 Dijagram poprečnih sila na krovnoj podrožnici (os y-y)

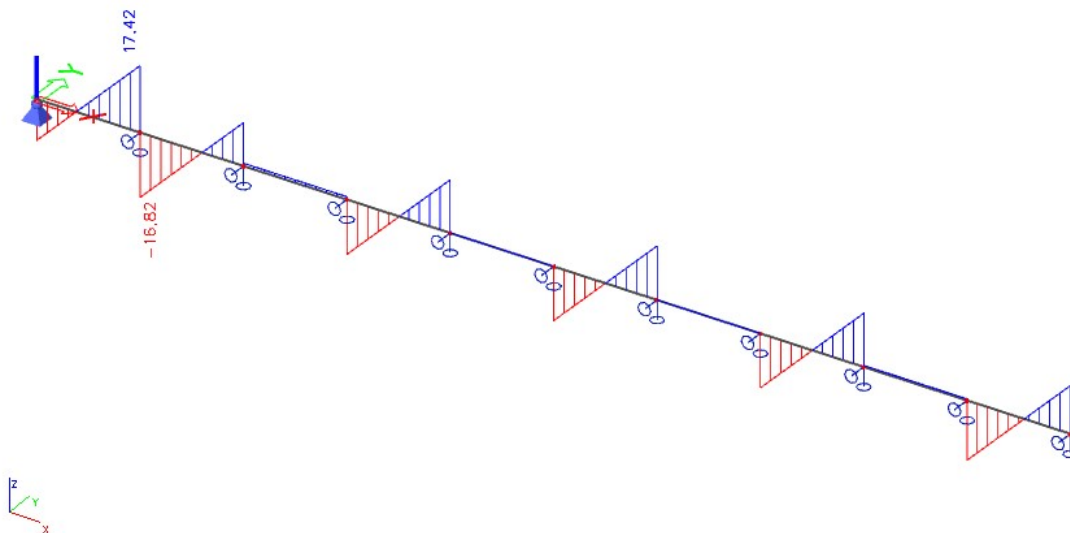

Slika 6.2.9 Dijagram poprečnih sila na krovnoj podrožnici (os z-z)

MOMENTNI DIJAGRAMI (kNm)

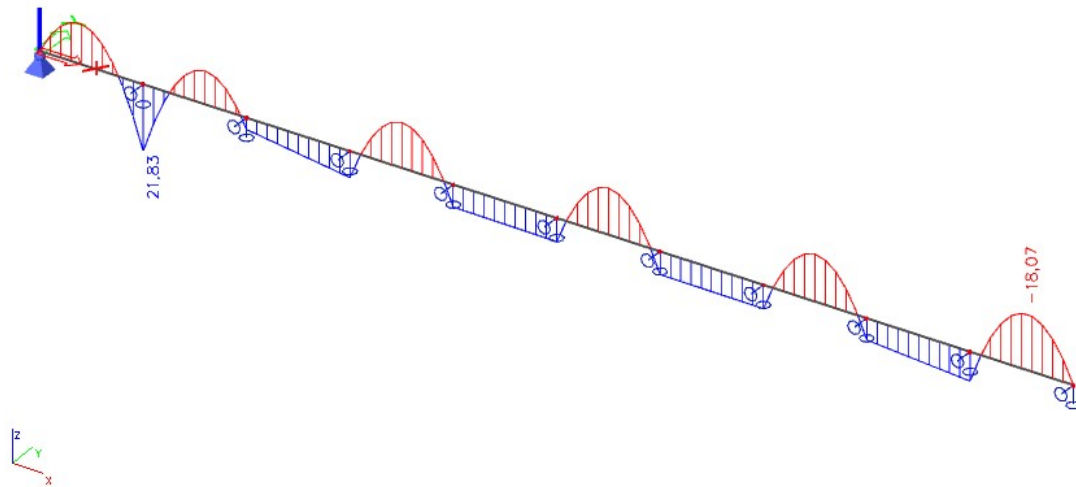

Slika 6.2.10 Momentni dijagram na krovnoj podrožnici (os y-y)

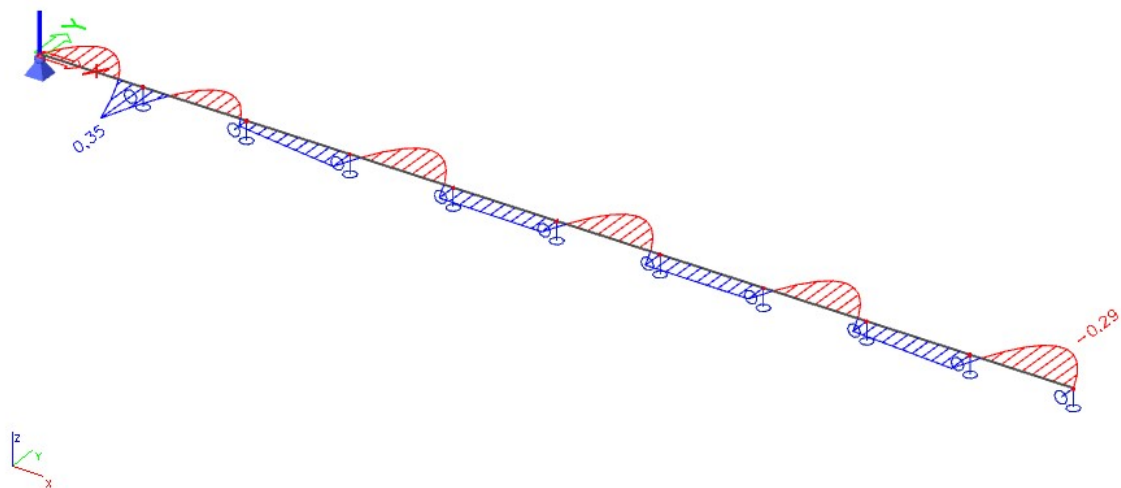

Slika 6.2.11 Momentni dijagram na krovnoj podrožnici (os z-z)

MAKSIMALNE REZNE SILE NA PODROŽNICI:

$$N_{ED} = 53,64 \text{ kN (TLAK)}$$

$$M_{z,ED} = 0,86 \text{ kNm}$$

$$M_{y,ED} = 21,81 \text{ kNm}$$

$$V_{z,ED} = 17,41 \text{ kN}$$

$$V_{y,ED} = 0,68 \text{ kN}$$

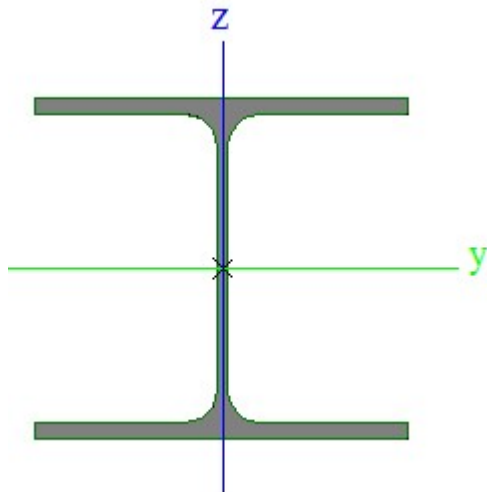
KROVNA PODROŽNICA

Profil: HEA 160A
Tip presjeka: valjani
Visina presjeka: $h = 148 \text{ mm}$
Širina presjeka: $b = 160 \text{ mm}$
Debljina pojasnice: $t_f = 7 \text{ mm}$
Debljina hrpta: $t_w = 5 \text{ mm}$
Radius: $r = 15 \text{ mm}$
Površina presjeka: $A = 30,4 \text{ cm}^2$
 $A_y = 21,88 \text{ cm}^2$
 $A_z = 7,22 \text{ cm}^2$

Momenti otpora: $I_y = 1280 \text{ cm}^4$
 $I_z = 479 \text{ cm}^4$
Momenti otpora: $W_{PL,y} = 190,42 \text{ cm}^3$
 $W_{PL,z} = 91,25 \text{ cm}^3$
Konstanta krivljenja: $I_w = 23751 \text{ cm}^6$
Torzijska konstanta: $I_t = 6,33 \text{ cm}^4$

Materijal: S235

$f_y = 235 \text{ MPa}$

$f_u = 360 \text{ Mpa}$

$E = 210 \text{ GPa} = 21000 \text{ kN/cm}^2$

$G = 8077 \text{ kN/cm}^2$

$\nu = 0,3$

KLASIFIKACIJA POPREČNOG PRESJEKA

HRBAT

$$c = h - 2r - 2t_f = 148 - (2 \cdot 15) - (2 \cdot 7) = 104 \text{ mm}$$

$$\frac{c}{t_w} \leq 72\varepsilon$$

$$\frac{104}{5} \leq 72 \cdot 1,0$$

$$20,8 < 72$$

HRBAT KLASA 1

POJASNICA

$$c = \frac{b - t_w - 2r}{2} = \frac{160 - 5 - 30}{2} = 62,5 \text{ mm}$$

$$\frac{c}{t_f} \leq 9\varepsilon$$

$$\frac{62,5}{9} \leq 9 \cdot 1,0$$

$$6,94 < 9,0$$

POJASNICA KLASA 1

POPREČNI PRESJEK KLASA 1

OTPORNOST POPREČNOG PRESJEKA

- NA UZDUŽNU SILU

$$N_{Rd} = \frac{A \cdot f_y}{\gamma_{M0}} = \frac{30,4 \cdot 23,5}{1,0} = 714,4 \text{ kN} > N_{Ed} = 53,64 \text{ kN}$$

- NA MOMENT SAVIJANJA

y-y

$$M_{c,y,Rd} = M_{PL,y,Rd} = \frac{W_{PL,y} \cdot f_y}{\gamma_{M0}} = \frac{190,42 \cdot 23,5}{1,0} = 4474,87 \text{ kNcm} = 44,75 \text{ kNm}$$

$$M_{c,y,Rd} = 44,75 \text{ kNm} > M_{y,ED} = 21,81 \text{ kNm}$$

z-z

$$M_{c,z,Rd} = M_{PL,z,Rd} = \frac{W_{PL,z} \cdot f_y}{\gamma_{M0}} = \frac{91,25 \cdot 23,5}{1,0} = 2144,38 \text{ kNcm} = 21,44 \text{ kNm}$$

$$M_{c,z,Rd} = 21,44 \text{ kNm} > M_{z,ED} = 0,86 \text{ kNm}$$

- NA POPREČNU SILU

$$c = h - 2r - 2t_f = 148 - (2 \cdot 15) - (2 \cdot 7) = 104 \text{ mm}$$

$$\frac{c}{t_w} \leq 72 \frac{\epsilon}{\eta}$$

$$\frac{104}{5} \leq 72 \cdot \frac{1,0}{1,2}$$

$$20,8 < 60$$

NIJE POTREBNA KONTROLA IZBOČAVANJA HRPTA

Z-Z

$$A_{V,z} = A - 2b \cdot t_f + (t_w + 2r) \cdot t_f \geq \eta \cdot h_w \cdot t_w$$

$$A_{V,z} = 30,4 - 2 \cdot 16 \cdot 0,7 + (0,5 + 2 \cdot 1,5) \cdot 0,7 \geq 1,2 \cdot 10,4 \cdot 0,5$$

$$A_{V,z} = 11,5 \text{ cm}^2 > 6,24 \text{ cm}^2$$

$$V_{PL,z,Rd} = \frac{A_{V,z} \cdot f_y}{\sqrt{3} \cdot \gamma_{M0}} = \frac{11,5 \cdot 23,5}{\sqrt{3} \cdot 1,0} = 156,03 \text{ kN} > V_{Ed} = 17,41 \text{ kN}$$

y-y

$$A_{V,y} = A - \Sigma h_w \cdot t_w$$

$$A_{V,y} = 30,4 - (10,4 \cdot 0,5) = 25,2 \text{ cm}^2$$

$$V_{PL,y,Rd} = \frac{A_{V,y} \cdot f_y}{\sqrt{3} \cdot \gamma_{M0}} = \frac{25,2 \cdot 23,5}{\sqrt{3} \cdot 1,0} = 341,91 \text{ kN} > V_{Ed} = 0,68 \text{ kN}$$

INTERAKCIJA M-N-V (DVOOSNO SAVIJANJE)

$$\left(\frac{M_{y,ED}}{M_{N,y,RD}} \right)^\alpha + \left(\frac{M_{z,ED}}{M_{N,z,RD}} \right)^\beta \leq 1,0$$

$$\alpha = 2 ; \beta = 5n \geq 1$$

$$n = \frac{N_{ED}}{N_{PL,RD}} = \frac{53,64}{714,4} = 0,07$$

$$\beta = 5 \cdot 0,07 = 0,35 \rightarrow \beta = 1$$

y-y

$$V_{Ed} < 0,5V_{PL,z,Rd}$$

$$17,41 \text{ kN} < 78,01 \text{ kN}$$

AKO SU ISPUNJENI SLJEDEĆI UVJETI NEMA REDUKCIJE OTPORNOSTI NA SAVIJANJE

$$1. N_{ED} \leq 0,25N_{PL,RD}$$

$$2. N_{ED} \leq \frac{0,5h_w \cdot t_w \cdot f_y}{\gamma_{M0}}$$

$$N_{ED} = 53,64 \text{ kN} \leq 0,25 \cdot 714,4 = 178,6 \text{ kN}$$

$$N_{ED} = 53,64 \text{ kN} \leq \frac{0,5 \cdot 10,4 \cdot 0,5 \cdot 23,5}{1,0} = 61,1 \text{ kN}$$

NEMA REDUKCIJE OTPORNOSTI NA SAVIJANJE OD UZDUŽNE SILE

$$M_{N,V,y,Rd} = 44,75 \text{ kNm} = M_{c,y,RD}$$

z-z

$$V_{Ed} < 0,5V_{PL,y,Rd}$$

$$0,68 \text{ kN} < 170,96 \text{ kN}$$

NEMA REDUKCIJE OTPORNOSTI NA POPREČNE SILE

NEMA REDUKCIJE OTPORNOSTI NA SAVIJANJE OD UZDUŽNE SILE

$$M_{N,V,z,Rd} = 21,44 \text{ kNm} = M_{c,z,RD}$$

$$\left(\frac{21,81}{44,75}\right)^2 + \left(\frac{0,86}{21,44}\right)^1 \leq 1,0$$

$$0,277 \leq 1,0$$

PROFILHEA160A ZADOVOLJAVA PROVJERE OTPORNOSTI NA RAZINI POPREČNOG PRESJEKA

OTPORNOST ELEMENTA IZLOŽENOG UZDUŽNOJ SILI I MOMENTU

UZDUŽNA TLAČNA OTPORNOST

$$\frac{h}{b} = \frac{148}{160} = 0,925$$

$$t_f = 7 \text{ mm}$$

ZA OS y-y → KRIVULJA IZVIJANJA b → $\alpha = 0,34$

ZA OS z-z → KRIVULJA IZVIJANJA c → $\alpha = 0,49$

y-y

$$N_{Sd} = 53,64 \text{ kN}$$

$$A = 30,4 \text{ cm}^2$$

$$N_{Pl,Rd} = 714,40 \text{ kN}$$

$$I = 1280 \text{ cm}^4$$

$$N_{CR} = 627,92 \text{ kN}$$

$$L_{CR} = 650 \text{ cm}$$

$$\lambda = 1,067$$

$$f_y = 235 \text{ N/mm}^2$$

$$\Phi = 1,216$$

$$\alpha = 0,34$$

$$\chi = 0,555$$

$$N_{b,Rd} = 396,78 \text{ kN}$$

z-z

$$N_{Sd} = 53,64 \text{ kN}$$

$$A = 30,4 \text{ cm}^2$$

$$N_{Pl,Rd} = 714,40 \text{ kN}$$

$$I = 479 \text{ cm}^4$$

$$N_{CR} = 234,98 \text{ kN}$$

$$L_{CR} = 650 \text{ cm}$$

$$\lambda = 1,744$$

$$f_y = 235 \text{ N/mm}^2$$

$$\Phi = 2,398$$

$$\alpha = 0,49$$

$$\chi = 0,247$$

$$N_{b,Rd} = 176,61 \text{ kN}$$

Iskoristivost:

$$\eta = \frac{N_{Sd}}{N_{b,Rd}} \cdot 100 = \frac{53,64}{176,61} \cdot 100 = 30,28\%$$

OTPORNOST ELEMENTA NA SAVIJANJE

$$M_{CR} = C_1 \cdot \frac{\pi^2 \cdot E \cdot I_z}{|k \cdot L|^2} \left[\sqrt{\left(\frac{k}{k_w}\right)^2 \cdot \frac{I_w}{I_z} + \frac{|k \cdot L|^2 \cdot G \cdot I_t}{\pi^2 \cdot E \cdot I_z} + |C_2 \cdot z_g|^2} - C_2 \cdot z_g \right]$$

$$z_g = 74 \text{ mm} = 7,4 \text{ cm}$$

$$L = 650,0 \text{ cm}$$

$$C_1 = 2,578$$

$$C_2 = 1,554$$

$$k = 1,0$$

$$k_w = 1,0$$

$$M_{CR} = 2,578 \cdot \frac{\pi^2 \cdot 21000 \cdot 479}{(1,0 \cdot 650)^2} \left[\sqrt{\left(\frac{1,0}{1,0}\right)^2 \cdot \frac{23751}{479} + \frac{(1,0 \cdot 650)^2 \cdot 8077 \cdot 6,33}{\pi^2 \cdot 21000 \cdot 479} + (1,554 \cdot 7,4)^2} - 1,554 \cdot 7,4 \right]$$

$$M_{CR} = 5140,36 \text{ kNcm} = 51,4 \text{ kNm}$$

$$\bar{\lambda}_{LT} = \sqrt{\frac{W_y \cdot f_y}{M_{CR}}} = \sqrt{\frac{190,42 \cdot 23,5}{5140,36}} = 0,933 > 0,4$$

$$h/b = 148/160 = 0,925$$

$$\text{KRIVULJA IZVIJANJA } a \rightarrow \alpha_{LT} = 0,21$$

$$\Phi_{LT} = 0,5 \left[1 + \alpha_{LT}(\bar{\lambda}_{LT} - 0,2) + \bar{\lambda}_{LT}^2 \right] = 0,5 \left[1 + 0,21(0,933 - 0,2) + 0,933^2 \right] = 1,012$$

$$\chi_{LT} = \frac{1}{\Phi_{LT} + \sqrt{\Phi_{LT}^2 - \bar{\lambda}_{LT}^2}} = \frac{1}{1,012 + \sqrt{1,012^2 - 0,933^2}} = 0,712$$

$$M_{b,Rd} = \chi_{LT} \cdot \frac{W_y \cdot f_y}{\gamma_{M1}} = 0,712 \cdot \frac{190,42 \cdot 23,5}{1,0} = 3186,11 \text{ kNcm} = 31,86 \text{ kNm} > M_{y,Ed} = 21,81 \text{ kNm}$$

INTERAKCIJA M-N

$$\frac{N_{ED}}{\chi_y \cdot N_{c,RD}/\gamma_{M1}} + k_{yy} \cdot \frac{M_{y,ED}}{\chi_{LT} \cdot M_{c,RD}/\gamma_{M1}} + k_{yz} \cdot \frac{M_{z,ED}}{M_{c,RD}/\gamma_{M1}} \leq 1,0$$

$$\frac{N_{ED}}{\chi_z \cdot N_{c,RD}/\gamma_{M1}} + k_{zy} \cdot \frac{M_{y,ED}}{\chi_{LT} \cdot M_{c,RD}/\gamma_{M1}} + k_{zz} \cdot \frac{M_{z,ED}}{M_{c,RD}/\gamma_{M1}} \leq 1,0$$

$$\Psi = 0$$

$$a_h = \frac{M_h}{M_s} = \frac{13,2}{21,81} = 0,6$$

$$C_{my}, C_{mz}, C_{mLT} = 0,2 + 0,8 a_h \geq 0,4$$

$$0,2 + 0,8 \cdot 0,6 \geq 0,4$$

$$0,68 \geq 0,4$$

$$k_{yy} = C_{my} \left(1 + (\bar{\lambda}_y - 0,2) \cdot \frac{N_{ED}}{\chi_y \cdot N_{RK}/\gamma_{M1}} \right) \leq C_{my} \left(1 + 0,8 \cdot \frac{N_{ED}}{\chi_y \cdot N_{RK}/\gamma_{M1}} \right)$$

$$k_{yz} = 0,6k_{zz}$$

$$k_{zy} = \left(1 - \frac{0,1 \cdot \bar{\lambda}_z}{C_{mLT} - 0,25} \cdot \frac{N_{ED}}{\chi_z \cdot N_{RK}/\gamma_{M1}} \right) \leq \left(1 - \frac{0,1}{C_{mLT} - 0,25} \cdot \frac{N_{ED}}{\chi_z \cdot N_{RK}/\gamma_{M1}} \right)$$

$$k_{zz} = C_{mz} \left(1 + (\bar{\lambda}_z - 0,6) \cdot \frac{N_{ED}}{\chi_z \cdot N_{RK}/\gamma_{M1}} \right) \leq C_{mz} \left(1 + 1,4 \cdot \frac{N_{ED}}{\chi_z \cdot N_{RK}/\gamma_{M1}} \right)$$

$$k_{yy} = 0,68 \left(1 + (1,067 - 0,2) \cdot \frac{53,47}{0,555 \cdot 714,4/1,0} \right) \leq 0,68 \left(1 + 0,8 \cdot \frac{53,64}{0,555 \cdot 714,4/1,0} \right)$$

$$k_{yy} = 0,760 \leq 0,808$$

$$k_{zz} = 0,68 \left(1 + (1,744 - 0,6) \cdot \frac{53,47}{0,247 \cdot 714,4/1,0} \right) \leq 0,68 \left(1 + 1,4 \cdot \frac{53,64}{0,247 \cdot 714,4/1,0} \right)$$

$$k_{zz} = 0,915 \leq 0,968$$

$$k_{yz} = 0,6 \cdot 0,915 = 0,549$$

$$k_{zy} = \left(1 - \frac{0,1 \cdot 1,744}{0,68 - 0,25} \cdot \frac{53,47}{0,247 \cdot 714,4/1,0} \right) \leq \left(1 - \frac{0,1}{0,68 - 0,25} \cdot \frac{53,64}{0,247 \cdot 714,4/1,0} \right)$$

$$k_{zy} = 0,877 \leq 0,929$$

$$\frac{53,64}{0,555 \cdot 714,4/1,0} + 0,76 \cdot \frac{21,81}{0,712 \cdot 44,75/1,0} + 0,549 \cdot \frac{0,86}{21,44/1,0} \leq 1,0$$

$$0,6771 < 1,0$$

$$\frac{53,64}{0,247 \cdot 714,4/1,0} + 0,877 \cdot \frac{21,81}{0,712 \cdot 44,75/1,0} + 0,915 \cdot \frac{0,86}{21,44/1,0} \leq 1,0$$

$$0,94 < 1,0$$

BOČNA PODROŽNICA

STALNO OPTEREĆENJE:

$\Delta g = 0,50 \text{ kn/m}^2$ (sekundarna konstrukcija + paneli + instalacije)

$$G = \Delta g \cdot x = 0,5 \cdot 2,25 = 1,125 \text{ kN/m}$$

$$W = W_D \cdot x = 0,69 \cdot 2,25 = 0,78 \text{ kN/m}$$

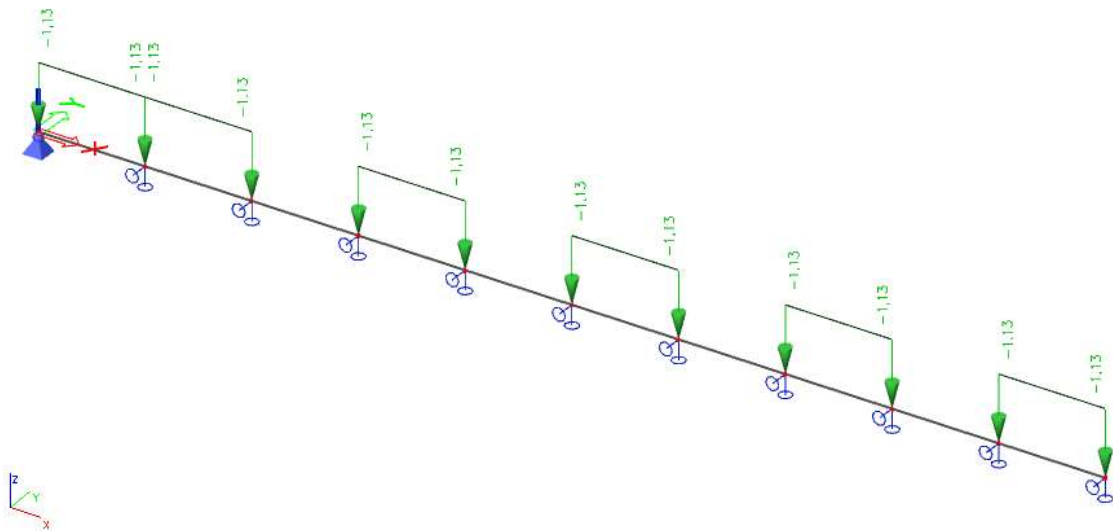

Slika 6.2.12 Stalno opterećenje na bočnu podrožnicu

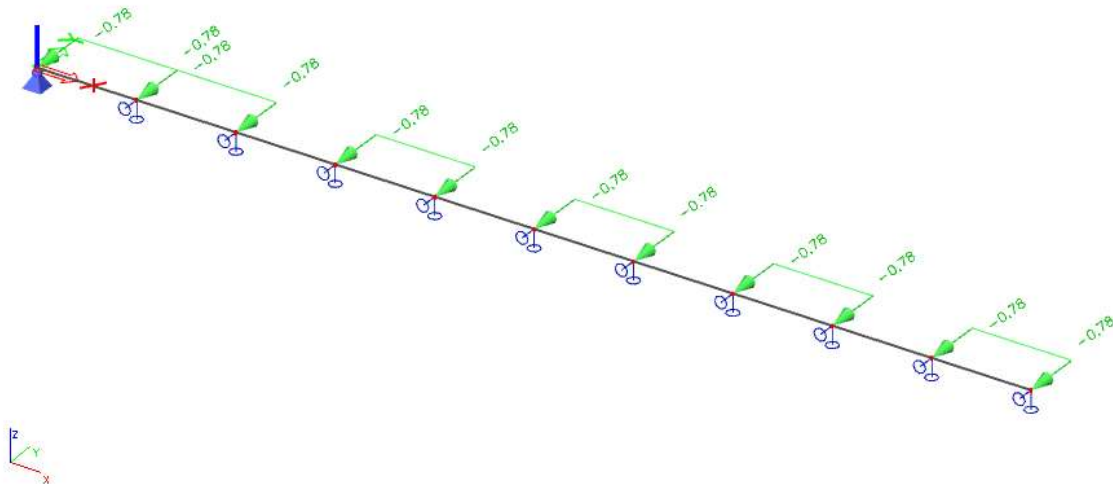

Slika 6.2.13 Opterećenje vjetra na bočnu podrožnicu

DIJAGRAMI REZNIH SILA NA BOČNU PODROŽNICU

KOMBINACIJA 1 (1,35G + 1,5W)

DIJAGRAMI POPREČNIH SILA (kN)

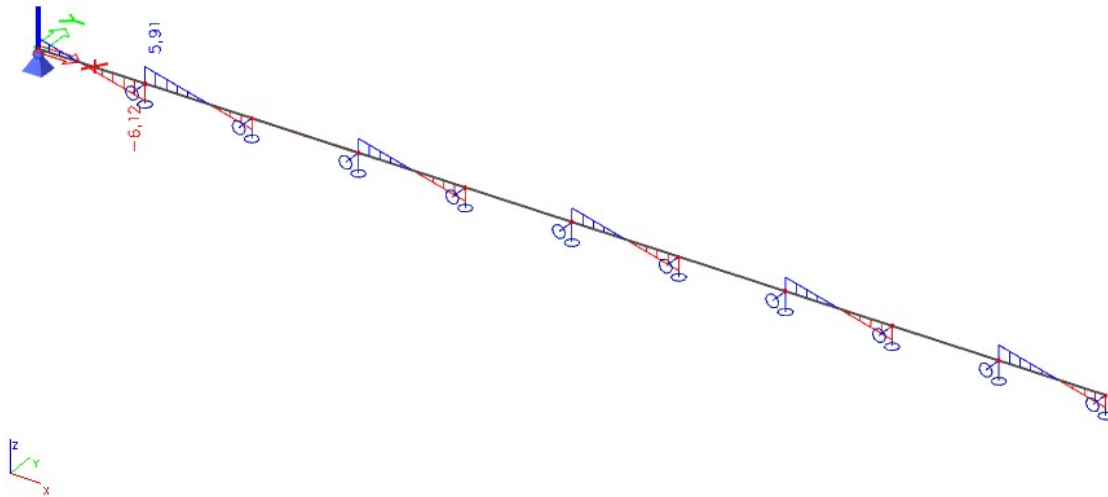

Slika 6.2.14 Dijagram poprečnih sila na bočnoj podrožnici (os y-y)

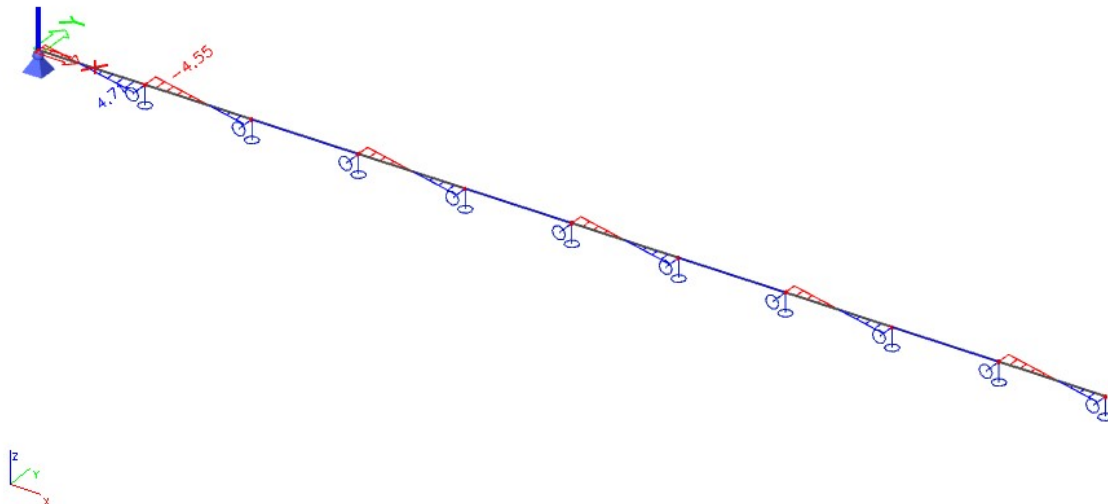

Slika 6.2.15 Dijagram poprečnih sila na bočnoj podrožnici (os z-z)

MOMENTNI DIJAGRAMI (kNm)

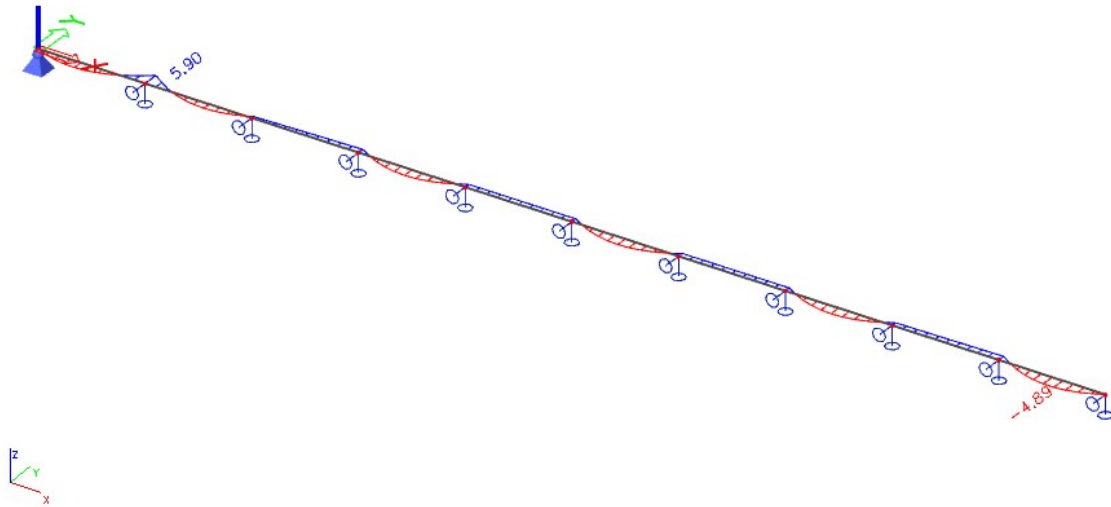

Slika 6.2.16 Momentni dijagram na bočnoj podrožnici (os y-y)

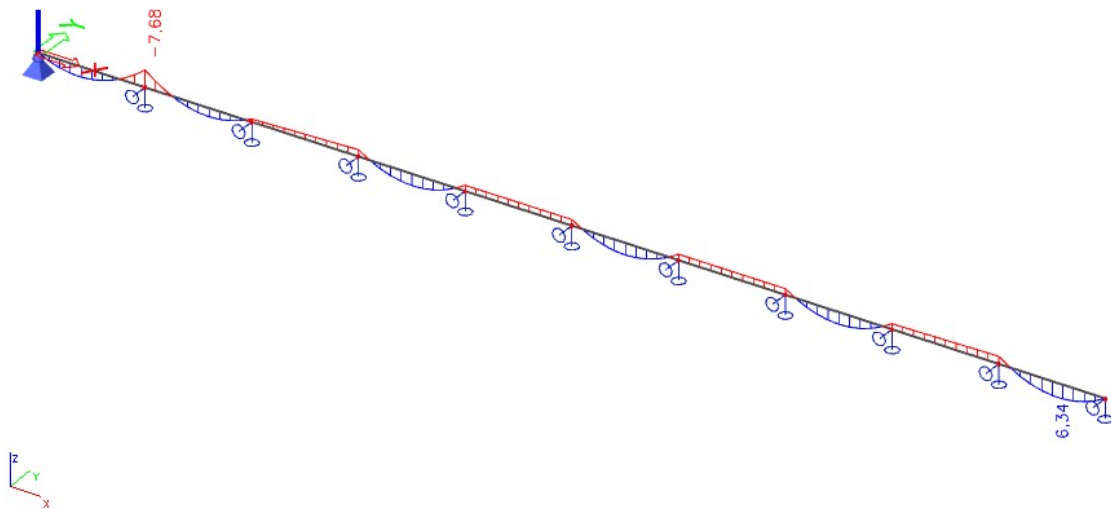

Slika 6.2.17 Momentni dijagram na bočnoj podrožnici (os z-z)

MAKSIMALNE REZNE SILE NA PODROŽNICI:

$$N_{ED} = 1,63 \text{ kN (VLAKE)}$$

$$M_{z,ED} = 7,68 \text{ kNm}$$

$$M_{y,ED} = 5,9 \text{ kNm}$$

$$V_{z,ED} = 4,71 \text{ kN}$$

$$V_{y,ED} = 6,12 \text{ kN}$$

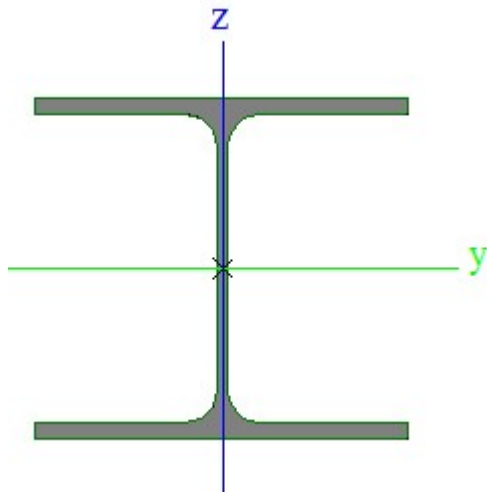
BOČNA PODROŽNICA

Profil: HEA 160A
Tip presjeka: valjani
Visina presjeka: $h = 148 \text{ mm}$
Širina presjeka: $b = 160 \text{ mm}$
Debljina pojasnice: $t_f = 7 \text{ mm}$
Debljina hrpta: $t_w = 5 \text{ mm}$
Radius: $r = 15 \text{ mm}$
Površina presjeka: $A = 30,4 \text{ cm}^2$
 $A_y = 21,88 \text{ cm}^2$
 $A_z = 7,22 \text{ cm}^2$

Momenti otpora: $I_y = 1280 \text{ cm}^4$
 $I_z = 479 \text{ cm}^4$
Momenti otpora: $W_{PL,y} = 190,42 \text{ cm}^3$
 $W_{PL,z} = 91,25 \text{ cm}^3$
Konstanta krivljenja: $I_w = 23751 \text{ cm}^6$
Torzijska konstanta: $I_t = 6,33 \text{ cm}^4$

Materijal: S235

$f_y = 235 \text{ MPa}$

$f_u = 360 \text{ Mpa}$

$E = 210 \text{ GPa} = 21000 \text{ kN/cm}^2$

$G = 8077 \text{ kN/cm}^2$

$\nu = 0,3$

KLASIFIKACIJA POPREČNOG PRESJEKA**HRBAT**

$$c = h - 2r - 2t_f = 148 - (2 \cdot 15) - (2 \cdot 7) = 104 \text{ mm}$$

$$\frac{c}{t_w} \leq 72\varepsilon$$

$$\frac{104}{5} \leq 72 \cdot 1,0$$

$$20,8 < 72$$

HRBAT KLASA 1**POJASNICA**

$$c = \frac{b - t_w - 2r}{2} = \frac{160 - 5 - 30}{2} = 62,5 \text{ mm}$$

$$\frac{c}{t_f} \leq 9\varepsilon$$

$$\frac{62,5}{9} \leq 9 \cdot 1,0$$

$$6,94 < 9,0$$

POJASNICA KLASA 1**POPREČNI PRESJEK KLASA 1**

OTPORNOST POPREČNOG PRESJEKA

- NA UZDUŽNU SILU

$$N_{Rd} = \frac{A \cdot f_y}{\gamma_{M0}} = \frac{30,4 \cdot 23,5}{1,0} = 714,4 \text{ kN} > N_{Ed} = 1,63 \text{ kN}$$

- NA MOMENT SAVIJANJA

y-y

$$M_{c,y,Rd} = M_{PL,y,Rd} = \frac{W_{PL,y} \cdot f_y}{\gamma_{M0}} = \frac{190,42 \cdot 23,5}{1,0} = 4474,87 \text{ kNcm} = 44,75 \text{ kNm}$$

$$M_{c,y,Rd} = 44,75 \text{ kNm} > M_{y,ED} = 5,9 \text{ kNm}$$

z-z

$$M_{c,z,Rd} = M_{PL,z,Rd} = \frac{W_{PL,z} \cdot f_y}{\gamma_{M0}} = \frac{91,25 \cdot 23,5}{1,0} = 2144,38 \text{ kNcm} = 21,44 \text{ kNm}$$

$$M_{c,z,Rd} = 21,44 \text{ kNm} > M_{z,ED} = 7,68 \text{ kNm}$$

- NA POPREČNE SILE

$$c = h - 2r - 2t_f = 148 - (2 \cdot 15) - (2 \cdot 7) = 104 \text{ mm}$$

$$\frac{c}{t_w} \leq 72 \frac{\varepsilon}{\eta}$$

$$\frac{104}{5} \leq 72 \cdot \frac{1,0}{1,2}$$

$$20,8 < 60$$

NIJE POTREBNA KONTROLA IZBOČAVANJA HRPTA

Z-Z

$$A_{V,z} = A - 2b \cdot t_f + (t_w + 2r) \cdot t_f \geq \eta \cdot h_w \cdot t_w$$

$$A_{V,z} = 30,4 - 2 \cdot 16 \cdot 0,7 + (0,5 + 2 \cdot 1,5) \cdot 0,7 \geq 1,2 \cdot 10,4 \cdot 0,5$$

$$A_{V,z} = 11,5 \text{ cm}^2 > 6,24 \text{ cm}^2$$

$$V_{PL,z,Rd} = \frac{A_{V,z} \cdot f_y}{\sqrt{3} \cdot \gamma_{M0}} = \frac{11,5 \cdot 23,5}{\sqrt{3} \cdot 1,0} = 156,03 \text{ kN} > V_{Ed} = 4,71 \text{ kN}$$

y-y

$$A_{V,y} = A - \Sigma h_w \cdot t_w$$

$$A_{V,y} = 30,4 - (10,4 \cdot 0,5) = 25,2 \text{ cm}^2$$

$$V_{PL,y,Rd} = \frac{A_{V,y} \cdot f_y}{\sqrt{3} \cdot \gamma_{M0}} = \frac{25,2 \cdot 23,5}{\sqrt{3} \cdot 1,0} = 341,91 \text{ kN} > V_{Ed} = 6,12 \text{ kN}$$

INTERAKCIJA M_y I M_z (DVOOSNO SAVIJANJE)

$$\left(\frac{M_{y,ED}}{M_{N,y,RD}} \right)^\alpha + \left(\frac{M_{z,ED}}{M_{N,z,RD}} \right)^\beta \leq 1,0$$

$$\alpha = 2 ; \beta = 1$$

y-y

$$V_{Ed} < 0,5V_{PL,z,Rd}$$

$$6,12 \text{ kN} < 78,01 \text{ kN}$$

$$M_{N,V,y,Rd} = 44,75 \text{ kNm} = M_{C,y,RD}$$

Z-Z

$$V_{Ed} < 0,5V_{PL,y,Rd}$$

$$4,71 \text{ kN} < 170,96 \text{ kN}$$

$$M_{N,V,z,Rd} = 21,44 \text{ kNm} = M_{C,z,RD}$$

NEMA REDUKCIJE OTPORNOSTI NA POPREČNE SILE

$$\left(\frac{5,9}{44,75}\right)^2 + \left(\frac{7,68}{21,44}\right)^2 \leq 1,0$$

$$0,38 \leq 1,0$$

PROFIL HEA160A ZADOVOLJAVA PROVJERE OTPORNOSTI NA RAZINI POPREČNOG PRESJEKA

OTPORNOST ELEMENTA NA SAVIJANJE

$$M_{CR} = C_1 \cdot \frac{\pi^2 \cdot E \cdot I_z}{|k \cdot L|^2} \left[\sqrt{\left(\frac{k}{k_w}\right)^2 \cdot \frac{I_w}{I_z} + \frac{|k \cdot L|^2 \cdot G \cdot I_t}{\pi^2 \cdot E \cdot I_z} + |C_2 \cdot z_g|^2} - C_2 \cdot z_g \right]$$

$$z_g = 74 \text{ mm} = 7,4 \text{ cm}$$

$$L = 650,0 \text{ cm}$$

$$C_1 = 2,578$$

$$C_2 = 1,554$$

$$k = 1,0$$

$$k_w = 1,0$$

$$M_{CR} = 2,578 \cdot \frac{\pi^2 \cdot 21000 \cdot 479}{(1,0 \cdot 650)^2} \left[\sqrt{\left(\frac{1,0}{1,0}\right)^2 \cdot \frac{23751}{479} + \frac{(1,0 \cdot 650)^2 \cdot 8077 \cdot 6,33}{\pi^2 \cdot 21000 \cdot 479} + (1,554 \cdot 7,4)^2} - 1,554 \cdot 7,4 \right]$$

$$M_{CR} = 5140,36 \text{ kNcm} = 51,4 \text{ kNm}$$

$$\bar{\lambda}_{LT} = \sqrt{\frac{W_y \cdot f_y}{M_{CR}}} = \sqrt{\frac{190,42 \cdot 23,5}{5140,36}} = 0,933 > 0,4$$

$$h/b = 148/160 = 0,925$$

$$\text{KRIVULJA IZVIJANJA } a \rightarrow \alpha_{LT} = 0,21$$

$$\Phi_{LT} = 0,5 \left[1 + \alpha_{LT}(\bar{\lambda}_{LT} - 0,2) + \bar{\lambda}_{LT}^2 \right] = 0,5[1 + 0,21(0,933 - 0,2) + 0,933^2] = 1,012$$

$$\chi_{LT} = \frac{1}{\Phi_{LT} + \sqrt{\Phi_{LT}^2 - \bar{\lambda}_{LT}^2}} = \frac{1}{1,012 + \sqrt{1,012^2 - 0,933^2}} = 0,712$$

$$M_{b,Rd} = \chi_{LT} \cdot \frac{W_y \cdot f_y}{\gamma_{M1}} = 0,712 \cdot \frac{190,42 \cdot 23,5}{1,0} = 3186,11 \text{ kNcm} = 31,86 \text{ kNm} > M_{y,Ed} = 5,9 \text{ kNm}$$

INTERAKCIJA M_y - M_z

$$k_{yy} \cdot \frac{M_{y,ED}}{\chi_{LT} \cdot M_{c,RD}/\gamma_{M1}} + k_{yz} \cdot \frac{M_{z,ED}}{M_{c,RD}/\gamma_{M1}} \leq 1,0$$

$$k_{zy} \cdot \frac{M_{y,ED}}{\chi_{LT} \cdot M_{c,RD}/\gamma_{M1}} + k_{zz} \cdot \frac{M_{z,ED}}{M_{c,RD}/\gamma_{M1}} \leq 1,0$$

$$\Psi = 0$$

$$a_h = \frac{M_h}{M_s} = \frac{3,57}{5,9} = 0,6$$

$$C_{my}, C_{mz}, C_{mLT} = 0,2 + 0,8 a_h \geq 0,4$$

$$0,2 + 0,8 \cdot 0,6 \geq 0,4$$

$$0,68 \geq 0,4$$

$$k_{yy} = C_{my} \left(1 + (\bar{\lambda}_y - 0,2) \cdot \frac{N_{ED}}{\chi_y \cdot N_{RK}/\gamma_{M1}} \right) \leq C_{my} \left(1 + 0,8 \cdot \frac{N_{ED}}{\chi_y \cdot N_{RK}/\gamma_{M1}} \right)$$

$$k_{yz} = 0,6k_{zz}$$

$$k_{zy} = \left(1 - \frac{0,1 \cdot \bar{\lambda}_z}{C_{mLT} - 0,25} \cdot \frac{N_{ED}}{\chi_z \cdot N_{RK}/\gamma_{M1}} \right) \leq \left(1 - \frac{0,1}{C_{mLT} - 0,25} \cdot \frac{N_{ED}}{\chi_z \cdot N_{RK}/\gamma_{M1}} \right)$$

$$k_{zz} = C_{mz} \left(1 + (\bar{\lambda}_z - 0,6) \cdot \frac{N_{ED}}{\chi_z \cdot N_{RK}/\gamma_{M1}} \right) \leq C_{mz} \left(1 + 1,4 \cdot \frac{N_{ED}}{\chi_z \cdot N_{RK}/\gamma_{M1}} \right)$$

$$k_{yy} = C_{my} = 0,68$$

$$k_{zz} = C_{mz} = 0,68$$

$$k_{yz} = 0,6 \cdot 0,68 = 0,408$$

$$k_{zy} = 1,0$$

$$0,68 \cdot \frac{5,9}{0,712 \cdot 44,75/1,0} + 0,408 \cdot \frac{7,68}{21,44/1,0} \leq 1,0$$

$$0,2721 < 1,0$$

$$0,68 \cdot \frac{5,9}{0,712 \cdot 44,75/1,0} + 1,0 \cdot \frac{7,68}{21,44/1,0} \leq 1,0$$

$$0,4841 < 1,0$$

6.3 DIMENZIONIRANJE SPREGOVA

KROVNI SPREG

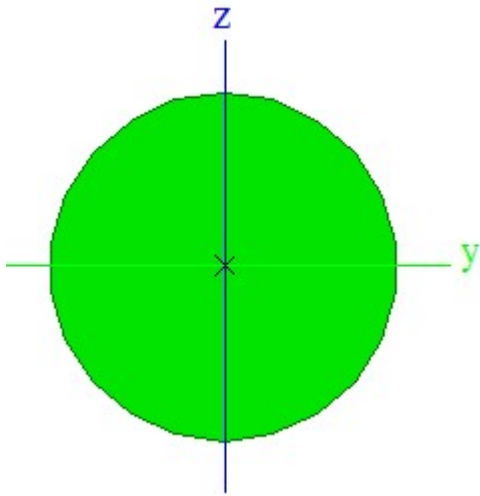

$$N_{ED} = 32,44 \text{ kN}$$

$$N_{ED} \leq \frac{A \cdot f_y}{\gamma_{M0}}$$

$$d \geq \sqrt{\frac{4 \cdot N_{ED} \cdot \gamma_{M0}}{\pi \cdot f_y}} = \sqrt{\frac{4 \cdot 32,44 \cdot 1,0}{\pi \cdot 23,5}} = 1,32 \text{ cm}$$

ODRABRANO $d = 14 \text{ mm}$

$$A = \frac{d^2 \cdot \pi}{4} = \frac{1,4^2 \cdot \pi}{4} = 1,54 \text{ cm}^2$$

$$N_{Rd} = \frac{A \cdot f_y}{\gamma_{M0}} = \frac{1,54 \cdot 23,5}{1,0} = 36,19 \text{ kN} > N_{Ed} = 21,6 \text{ kN}$$

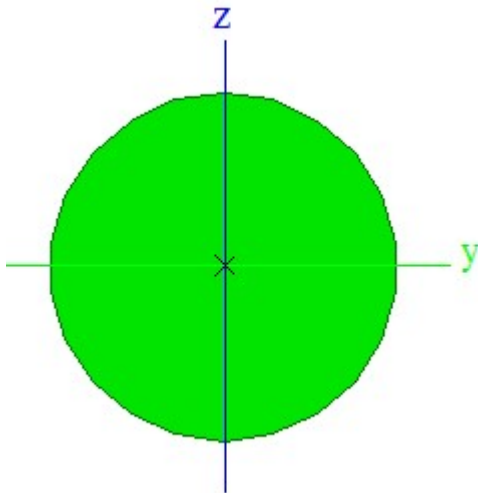
BOČNI SPREG

$$N_{ED} = 58,78 \text{ kN}$$

$$N_{ED} \leq \frac{A \cdot f_y}{\gamma_{M0}}$$

$$d \geq \sqrt{\frac{4 \cdot N_{ED} \cdot \gamma_{M0}}{\pi \cdot f_y}} = \sqrt{\frac{4 \cdot 58,78 \cdot 1,0}{\pi \cdot 23,5}} = 1,78 \text{ cm}$$

ODRABRANO $d = 18 \text{ mm}$

$$A = \frac{d^2 \cdot \pi}{4} = \frac{1,8^2 \cdot \pi}{4} = 2,54 \text{ cm}^2$$

$$N_{Rd} = \frac{A \cdot f_y}{\gamma_{M0}} = \frac{2,54 \cdot 23,5}{1,0} = 59,69 \text{ kN} > N_{Ed} = 58,78 \text{ kN}$$

7. DIMENZIONIRANJE SPOJEVA

7.1 UPETI SPOJ STUP - TEMELJ

STUP HEA320

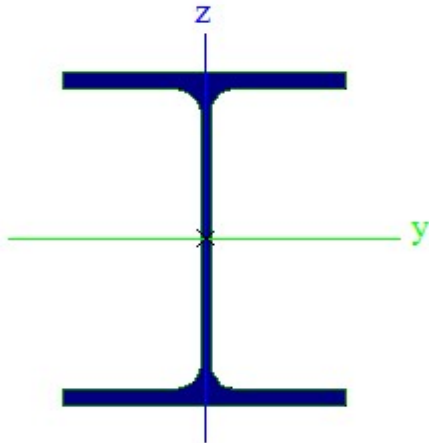

Profil:	HEA 320
Tip presjeka:	valjani
Visina presjeka:	$h = 310 \text{ mm}$
Širina presjeka:	$b = 300 \text{ mm}$
Debljina pojasnice:	$t_f = 16 \text{ mm}$
Debljina hrpta:	$t_w = 9 \text{ mm}$
Radius:	$r = 27 \text{ mm}$
Površina presjeka:	$A = 124 \text{ cm}^2$
	$A_y = 89,52 \text{ cm}^2$
	$A_z = 27,75 \text{ cm}^2$

Momenti otpora:	$I_y = 22900 \text{ cm}^4$
	$I_z = 6990 \text{ cm}^4$
Momenti otpora:	$W_{PL,y} = 1629,2 \text{ cm}^3$
	$W_{PL,z} = 708,33 \text{ cm}^3$
Konstanta krivljenja:	$I_w = 1512400 \text{ cm}^6$
Torzijska konstanta:	$I_t = 108 \text{ cm}^4$

Materijal: S235

$f_y = 235 \text{ MPa}$

$f_u = 360 \text{ MPa}$

$E = 210 \text{ GPa} = 21000 \text{ kN/cm}^2$

$G = 8077 \text{ kN/cm}^2$

$\nu = 0,3$

ULAZNI PODACI

DJELUJUĆE SILE

$N_{Ed} = 137,48 \text{ kN (TLAK)}$

$M_{Ed} = 241,09 \text{ kNm}$

$V_{Ed} = 71,69 \text{ kN}$

Vijci k.v. 8.8

POJASNICE

VLAČNA SILA U POJASU OD MOMENTA SAVIJANJA

$$N_p^M = \frac{M_{Ed}}{h'} = \frac{241,09}{(0,31 - 0,016)} = 820,03 \text{ kN}$$

TLAČNA SILA U POJASU OD UZDUŽNE SILE

$$N_p^N = \frac{A_p}{A} \cdot N_{Ed} = \frac{30 \cdot 1,6}{124} \cdot (-137,48) = -53,22 \text{ kN}$$

UKUPNA SILA U VLAČNOJ POJASNICI

$$N_p = N_p^M + N_p^N = 820,03 - 53,22 = 766,81 \text{ kN}$$

KONTROLA VAROVA

DUŽINA VARA HRPTA

$$L \approx 2 \cdot 278 = 556 \text{ mm}$$

DUŽINA VARA POJASNICE

$$L \approx 2 \cdot 300 = 600 \text{ mm}$$

MAKSIMALNA DEBLJINA VARA S OBZIROM NA DEBLJINU HRPTA NOSAČA

$$a_{\max} = 0,7 \cdot t_{\min} = 0,7 \cdot 9 = 6,3 \text{ mm}$$

ZA PRETOPSTAVLJENI VAR $a = 6 \text{ mm}$

MAKSIMALNA DEBLJINA VARA S OBZIROM NA DEBLJINU POJASA NOSAČA

$$a_{\max} = 0,7 \cdot t_{\min} = 0,7 \cdot 16 = 11,2 \text{ mm}$$

ZA PRETOPSTAVLJENI VAR $a = 7 \text{ mm}$

$a = 6 \text{ mm}$, S235; $F_{w,Rk} = 155,9 \text{ kN}$

$a = 7 \text{ mm}$, S235; $F_{w,Rk} = 181,9 \text{ kN}$

UZDUŽNA SILA

$$F_{w,Rd} = \frac{F_{w,Rk}}{1,25} \cdot \frac{L}{100} = \frac{181,9}{1,25} \cdot \frac{600}{100} = 873,12 \text{ kN} > N_p = 766,81 \text{ kN}$$

POPREČNA SILA

$$F_{w,Rd} = \frac{F_{w,Rk}}{1,25} \cdot \frac{L}{100} = \frac{155,9}{1,25} \cdot \frac{556}{100} = 693,44 \text{ kN} > N_p = 71,69 \text{ kN}$$

PRORAČUN VIJAKA

VIJCI M-30

k.v. 8.8

$$c_{\min} = 2d + a\sqrt{2} = 2 \cdot 30 + 7\sqrt{2} = 69,89 \text{ mm} \rightarrow c = 70 \text{ mm}$$

EKSCENTRICITET UZDUŽNE SILE

$$e = \frac{M_{Ed}}{N_{Ed}} = \frac{240,09}{137,48} = 1,75 \text{ m}$$

EKSCENTRICITET X_1

$$X_1 = 70 + 310 - 8 = 372 \text{ mm} = 0,372 \text{ m}$$

EKSCENTRICITET X_2

$$X_2 = 1750 - 310/2 + 8 = 1603 \text{ mm} = 1,603 \text{ m}$$

$$F_{t,Sd} = N_{Ed} \cdot \frac{X_2}{X_1} = 137,48 \cdot \frac{1,603}{0,372} = 592,42 \text{ kN}$$

OTPORNOST VIJAKA NA VLAK

$$F_{t,Rd} = \frac{F_{t,Rk}}{\gamma_{M1}} = \frac{403,9}{1,25} = 323,12 \text{ kN} \geq \frac{F_{t,Sd}}{2} = 296,21 \text{ kN}$$

OTPORNOST VIJAKA NA POSMIK

$$F_{v,Rd} = \frac{F_{v,Rk}}{\gamma_{M1}} = \frac{269,3}{1,25} = 215,44 \text{ kN} \geq \frac{V_{Sd}}{4} = 17,92 \text{ kN}$$

INTERAKCIJA UZDUŽNE I POSMIČNE SILE NA VIJAK

$$\frac{F_{v,Sd}}{F_{v,Rd}} + \frac{F_{t,Sd}}{1,4 \cdot F_{t,Rd}} \leq 1,0$$

$$\frac{17,92}{215,44} + \frac{296,21}{1,4 \cdot 323,12} \leq 1,0$$

$$0,738 < 1,0$$

PRORAČUN DIMENZIJA PLOČE

$$a_{pl}^{\min} = h + 2(c + e_1) = 310 + 2(70 + 75) = 600 \text{ mm}$$

$$b_{pl}^{\min} = b + 2a\sqrt{2} + 20 = 300 + 2 \cdot 7 \cdot \sqrt{2} + 20 = 339,79 \text{ mm}$$

$$b_{pl}^{\min} = p_2 + 2e_2 = 100 + 2 \cdot 60 = 220 \text{ mm}$$

DIMENZIJE PLOČE SU 600×340 mm

PRORAČUN DEBLJINE PLOČEPRITISAK PO OMOTAČU RUPE OSNOVNOG OMOTAČA

$$F_{b,Sd} = F_{v,Sd} = 17,92 \text{ kN}$$

$$F_{b,Rd} = \frac{F_{b,Rk}}{1,25} \cdot \frac{t_{pl}}{10} = \frac{204,5}{12,5} \cdot t_{pl} = 17,92 \cdot t_{pl} \rightarrow t_{pl}^{\min} = 1 \text{ mm}$$

SAVIJANJE PLOČE OD ODGOVORA BETONSKE PODLOGE

$$s = (600 - 310 - 16)/2 = 137 \text{ mm} = 13,7 \text{ cm}$$

$$R = F_{t,Sd} + N_{Sd} = 592,42 - 137,48 = 454,94 \text{ kN}$$

NAPREZANJE NA BETONU

$$f_{B,Sd} = \frac{R}{\frac{3 \cdot s \cdot b_{pl}}{2}} = \frac{454,94}{\frac{3 \cdot 13,7 \cdot 34}{2}} = 0,65 \frac{\text{kN}}{\text{cm}^2} \leq \frac{f_{ck}}{1,5} = \frac{25}{1,5} = 1,67 \frac{\text{kN}}{\text{cm}^2}$$

SAVIJANJE PLOČE

$$M_{Sd} = F_1 \cdot \frac{s}{2} + F_2 \cdot \frac{2}{3}s = \frac{2}{3}f_{B,Sd} \cdot s \cdot b_{pl} \cdot \frac{s}{2} + \frac{1}{3}f_{B,Sd} \cdot s \cdot b_{pl} \cdot \frac{2}{3}s =$$

$$M_{Sd} = \frac{2}{3} \cdot 6500 \cdot 0,137 \cdot 0,34 \cdot \frac{0,137}{2} + \frac{1}{3} \cdot 6500 \cdot 0,137 \cdot 0,34 \cdot \frac{2}{3} \cdot 0,137 =$$

$$M_{Sd} = 18,44 \text{ kNm}$$

SAVIJANJE PLOČE OD VLAČNIH VIJAKA

$$M_{Sd} = F_{t,Sd} \cdot \left(c + \frac{t_f}{2} \right) = 592,42 \cdot 0,078 = 46,21 \text{ kNm}$$

$$t_{\min} = \sqrt{\frac{1,1 \cdot M_{Sd} \cdot 6}{b_{pl} \cdot f_y}} = \sqrt{\frac{1,1 \cdot 4621 \cdot 6}{34 \cdot 23,5}} = 6,17 \text{ cm} \rightarrow 62 \text{ mm}$$

$$t = 40 \text{ mm}$$

POTREBNO JE STAVITI UKRUTE**USVOJENE DIMENZIJE PLOČE: 600×340×40 mm**

7.2 DIMENZIONIRANJE SPOJA STUP-GREDA

GREDA HEA340

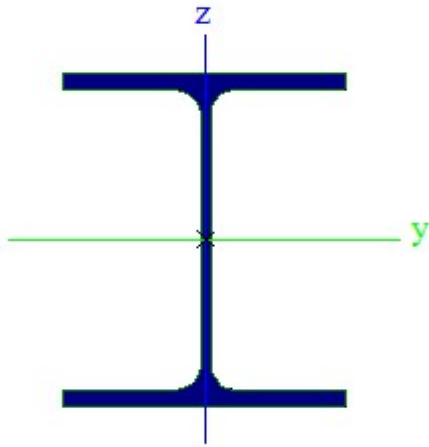

Profil: HEA 340
Tip presjeka: valjani
Visina presjeka: $h = 330 \text{ mm}$
Širina presjeka: $b = 300 \text{ mm}$
Debljina pojasnice: $t_f = 17 \text{ mm}$
Debljina hrpta: $t_w = 10 \text{ mm}$
Radius: $r = 27 \text{ mm}$
Površina presjeka: $A = 134 \text{ cm}^2$
 $A_y = 95,5 \text{ cm}^2$
 $A_z = 33,2 \text{ cm}^2$

Momenti otpora: $I_y = 27700 \text{ cm}^4$
 $I_z = 7440 \text{ cm}^4$
Momenti otpora: $W_{PL,y} = 1850 \text{ cm}^3$
 $W_{PL,z} = 754,17 \text{ cm}^3$
Konstanta krivljenja: $I_w = 1824400 \text{ cm}^6$
Torzijska konstanta: $I_t = 127 \text{ cm}^4$

Materijal: S235

$f_y = 235 \text{ MPa}$

$f_u = 360 \text{ MPa}$

$E = 210 \text{ GPa} = 21000 \text{ kN/cm}^2$

$G = 8077 \text{ kN/cm}^2$

$\nu = 0,3$

OSNOVNI MATERIJAL: S235

Vijci k.v. 8.8

DJELUJUĆE SILE

$$N_{Ed} = 58,72 \text{ kN (TLAK)}$$

$$M_{Ed} = 260,43 \text{ kNm}$$

$$V_{Ed} = 80,11 \text{ kN}$$

DIMENZIJE PLOČE 680×320×20 mm

POJASNICE

VLAČNA SILA U POJASU OD MOMENTA SAVIJANJA

$$N_p^M = \frac{M_{Ed}}{h'} = \frac{260,43}{(0,8 \cdot h_p)} = 478,73 \text{ kN}$$

TLAČNA SILA U POJASU OD UZDUŽNE SILE

$$N_p^N = \frac{A_p}{A} \cdot N_{Ed} = \frac{30 \cdot 1,7}{134} \cdot (-58,72) = -22,35 \text{ kN}$$

UKUPNA SILA U VLAČNOJ POJASNICI

$$N_p = N_p^M + N_p^N = 832,0 - 22,35 = 456,38 \text{ kN}$$

KONTROLA VAROVA

DUŽINA VARA HRPTA

$$L \approx 2 \cdot 296 = 592 \text{ mm}$$

DUŽINA VARA POJASNICE

$$L \approx 2 \cdot 300 = 600 \text{ mm}$$

MAKSIMALNA DEBLJINA VARA S OBZIROM NA DEBLJINU HRPTA NOSAČA

$$a_{\max} = 0,7 \cdot t_{\min} = 0,7 \cdot 10 = 7,0 \text{ mm}$$

ZA PRETOPSTAVLJENI VAR a = 7 mm

$$a = 7 \text{ mm, S235; } F_{w,Rk} = 181,9 \text{ kN}$$

UZDUŽNA SILA

$$F_{w,Rd} = \frac{F_{w,Rk}}{1,25} \cdot \frac{L}{100} = \frac{181,9}{1,25} \cdot \frac{600}{100} = 873,12 \text{ kN} > N_p = 456,38 \text{ kN}$$

POPREČNA SILA

$$F_{w,Rd} = \frac{F_{w,Rk}}{1,25} \cdot \frac{L}{100} = \frac{181,9}{1,25} \cdot \frac{592}{100} = 861,48 \text{ kN} > N_p = 80,11 \text{ kN}$$

PRORAČUN VIJAKA

VIJCI M-22

k.v. 8.8

$$c_{\min} = 2d + a\sqrt{2} = 2 \cdot 22 + 7\sqrt{2} = 53,9 \text{ mm} \rightarrow c = 55 \text{ mm}$$

OTPORNOST VIJAKA NA VLAK

$$F_{t,Rd} = \frac{F_{t,Rk}}{\gamma_{M1}} = \frac{218,2}{1,25} = 174,56 \text{ kN} \geq \frac{F_{t,Sd}}{4} = 114,1 \text{ kN}$$

OTPORNOST VIJAKA NA POSMIK

$$F_{v,Rd} = \frac{F_{v,Rk}}{\gamma_{M1}} = \frac{117,6}{1,25} = 94,08 \text{ kN} \geq \frac{V_{Sd}}{6} = 13,35 \text{ kN}$$

INTERAKCIJA UZDUŽNE I POSMIČNE SILE NA VIJAK

$$\frac{F_{v,Sd}}{F_{v,Rd}} + \frac{F_{t,Sd}}{1,4 \cdot F_{t,Rd}} \leq 1,0$$

$$\frac{13,35}{94,08} + \frac{114,1}{1,4 \cdot 174,56} \leq 1,0$$

$$0,608 < 1,0$$

7.3 DIMENZIONIRANJE SPOJA NASTAVKA KROVNIH I BOČNIH PODROŽNICA

KROVNA PODROŽNICA

ULAZNI PODACI

$$N_{Ed} = 0$$

$$M_{Ed} = 15,42 \text{ kNm}$$

$$V_{Ed} = 2,76 \text{ kN}$$

MATERIJAL

OSNOVNI MATERIJAL: S235

Vijci k.v. 5.6

POPREČNI PREJEK PROFIL: HEA160A

$$h = 148 \text{ mm}$$

$$b = 160 \text{ mm}$$

$$t_f = 7 \text{ mm}$$

$$t_w = 5 \text{ mm}$$

$$r = 15 \text{ mm}$$

VLAČNA SILA U POJASU OD MOMENTA SAVIJANJA

$$N_p^M = \frac{M_{Ed}}{h'} = \frac{15,42}{(0,148 - 0,005)} = 107,83 \text{ kN}$$

VLAČNA SILA U POJASU OD UZDUŽNE SILE

$$N_p^N = \frac{A_p}{A} \cdot N_{Ed} = 0 \text{ kN}$$

UKUPNA SILA U VLAČNOJ POJASNICI

$$N_p = N_p^M + N_p^N = 107,83 + 0 = 107,83 \text{ kN}$$

KONTROLA VAROVA

DUŽINA VARA HRPTA

$$L \approx 2 \cdot 134 = 268 \text{ mm}$$

DUŽINA VARA POJASNICE

$$L \approx 2 \cdot 160 = 320 \text{ mm}$$

MAKSIMALNA DEBLJINA VARA S OBZIROM NA DEBLJINU HRPTA I POJASEVA NOSAČA

$$a_{\max} = 0,7 \cdot t_{\min} = 0,7 \cdot 5 = 3,5 \text{ mm}$$

ZA PRETOPSTAVLJENI VAR $a = 3 \text{ mm}$

$a = 3 \text{ mm}$, S235; $F_{w,Rk} = 181,9 \text{ kN}$

UZDUŽNA SILA

$$F_{w,Rd} = \frac{F_{w,Rk}}{1,25} \cdot \frac{L}{100} = \frac{77,9 \cdot 320}{1,25 \cdot 100} = 199,42 \text{ kN} > N_p = 107,83 \text{ kN}$$

POPREČNA SILA

$$F_{w,Rd} = \frac{F_{w,Rk}}{1,25} \cdot \frac{L}{100} = \frac{77,9 \cdot 268}{1,25 \cdot 100} = 167,02 \text{ kN} > V_{ED} = 2,76 \text{ kN}$$

PRORAČUN VIJAKA

VIJCI M-16

k.v. 5.6

$$c_{\min} = 2d + a\sqrt{2} = 2 \cdot 16 + 3\sqrt{2} = 36,24 \text{ mm} \rightarrow c = 37 \text{ mm}$$

OTPORNOST VIJAKA NA VLAKE

$$F_{t,Rd} = \frac{F_{t,Rk}}{\gamma_{M1}} = \frac{70,7}{1,25} = 56,56 \text{ kN} \geq \frac{N_p}{2} = 53,92 \text{ kN}$$

OTPORNOST VIJAKA NA POSMIK

$$F_{v,Rd} = \frac{F_{v,Rk}}{\gamma_{M1}} = \frac{47,1}{1,25} = 37,68 \text{ kN} \geq \frac{V_{Sd}}{6} = 0,46 \text{ kN}$$

INTERAKCIJA UZDUŽNE I POSMIČNE SILE NA VIJAK

$$\frac{F_{V,Sd}}{F_{V,Rd}} + \frac{F_{t,Sd}}{1,4 \cdot F_{t,Rd}} \leq 1,0$$

$$\frac{0,46}{37,68} + \frac{53,92}{1,4 \cdot 56,56} \leq 1,0$$

$$0,69 < 1,0$$

PRORAČUN DIMENZIJA PLOČE

$$a_{pl}^{\min} = h + c + e_1 = 148 + 37 + 30 = 215 \text{ mm}$$

$$b_{pl}^{\min} = p_2 + 2e_2 = 55 + 2 \cdot 30 = 115 \text{ mm}$$

DIMENZIJE PLOČE SU 160×215 mm

PRORAČUN DEBLJINE PLOČE

PRITISAK PO OMOTAČU RUPE OSNOVNOG OMOTAČA

$$F_{b,Sd} = F_{v,Sd} = 0,46 \text{ kN}$$

$$F_{b,Rd} = \frac{F_{b,Rk}}{1,25} \cdot \frac{t_{pl}}{10} = \frac{106,7}{12,5} \cdot t_{pl} = 8,54 \cdot t_{pl} \rightarrow t_{pl}^{\min} = 1 \text{ mm}$$

SAVIJANJE PLOČE OD VLAČNIH VIJAKA

$$M_{Sd} = F_{t,Sd} \cdot c = 53,92 \cdot 0,037 = 2,00 \text{ kNm}$$

$$t_{\min} = \sqrt{\frac{1,1 \cdot M_{Sd} \cdot 6}{b_{pl} \cdot f_y}} = \sqrt{\frac{1,1 \cdot 200 \cdot 6}{160 \cdot 23,5}} = 0,59 \text{ cm} \rightarrow 1,0 \text{ cm} = 10 \text{ mm}$$

$$t = 10 \text{ mm}$$

USVOJENE DIMENZIJE PLOČE: 160×215×10 mm

BOČNE PODROŽNICE

ULAZNI PODACI

$$N_{ed} = 0$$

$$M_{ed} = 5,42 \text{ kNm}$$

$$V_{ed} = 0,98 \text{ kN}$$

MATERIJAL:

OSNOVNI MATERIJAL: S235

VIJCI k.v. 4.6

POPREČNI PREJEK: HEA160A

$$h = 148 \text{ mm}$$

$$b = 160 \text{ mm}$$

$$t_f = 7 \text{ mm}$$

$$t_w = 5 \text{ mm}$$

$$r = 15 \text{ mm}$$

VLAČNA SILA U POJASU OD MOMENTA SAVIJANJA

$$N_p^M = \frac{M_{Ed}}{h'} = \frac{5,42}{(0,148 - 0,005)} = 37,90 \text{ kN}$$

VLAČNA SILA U POJASU OD UZDUŽNE SILE

$$N_p^N = \frac{A_p}{A} \cdot N_{Ed} = 0 \text{ kN}$$

UKUPNA SILA U VLAČNOJ POJASNICI

$$N_p = N_p^M + N_p^N = 37,90 + 0 = 37,90 \text{ kN}$$

KONTROLA VAROVA

DUŽINA VARA HRPTA

$$L \approx 2 \cdot 134 = 268 \text{ mm}$$

DUŽINA VARA POJASNICE

$$L \approx 2 \cdot 160 = 320 \text{ mm}$$

MAKSIMALNA DEBLJINA VARA S OBZIROM NA DEBLJINU HRPTA I POJASEVA NOSAČA

$$a_{\max} = 0,7 \cdot t_{\min} = 0,7 \cdot 5 = 3,5 \text{ mm}$$

ZA PRETOPSTAVLJENI VAR $a = 3 \text{ mm}$

$a = 3 \text{ mm}$, S235; $F_{w,Rk} = 181,9 \text{ kN}$

UZDUŽNA SILA

$$F_{w,Rd} = \frac{F_{w,Rk}}{1,25} \cdot \frac{L}{100} = \frac{77,9}{1,25} \cdot \frac{320}{100} = 199,42 \text{ kN} > N_p = 37,90 \text{ kN}$$

POPREČNA SILA

$$F_{w,Rd} = \frac{F_{w,Rk}}{1,25} \cdot \frac{L}{100} = \frac{77,9}{1,25} \cdot \frac{268}{100} = 167,02 \text{ kN} > V_{ED} = 0,98 \text{ kN}$$

PRORAČUN VIJAKA

VIJCI M-12

k.v. 4.6

$$c_{\min} = 2d + a\sqrt{2} = 2 \cdot 16 + 3\sqrt{2} = 28,24 \text{ mm} \rightarrow c = 30 \text{ mm}$$

OTPORNOST VIJAKA NA VLAKE

$$F_{t,Rd} = \frac{F_{t,Rk}}{\gamma_{M1}} = \frac{30,3}{1,25} = 24,24 \text{ kN} \geq \frac{N_p}{2} = 18,95 \text{ kN}$$

OTPORNOST VIJAKA NA POSMIK

$$F_{v,Rd} = \frac{F_{v,Rk}}{\gamma_{M1}} = \frac{20,2}{1,25} = 16,16 \text{ kN} \geq \frac{V_{Sd}}{6} = 0,17 \text{ kN}$$

INTERAKCIJA UZDUŽNE I POSMIČNE SILE NA VIJAK

$$\frac{F_{V,Sd}}{F_{V,Rd}} + \frac{F_{t,Sd}}{1,4 \cdot F_{t,Rd}} \leq 1,0$$

$$\frac{0,17}{16,16} + \frac{18,95}{1,4 \cdot 24,24} \leq 1,0$$

$$0,57 < 1,0$$

PRORAČUN DIMENZIJA PLOČE

$$a_{pl}^{\min} = h + 2(c + e_1) = 148 + 2(30 + 30) = 268 \text{ mm}$$

$$b_{pl}^{\min} = p_2 + 2e_2 = 40 + 2 \cdot 25 = 90 \text{ mm}$$

DIMENZIJE PLOČE SU 160×215 mm

PRORAČUN DEBLJINE PLOČE

PRITISAK PO OMOTAČU RUPE OSNOVNOG MATERIJALA

$$F_{b,Sd} = F_{v,Sd} = 0,17 \text{ kN}$$

$$F_{b,Rd} = \frac{F_{b,Rk}}{1,25} \cdot \frac{t_{pl}}{10} = \frac{83,1}{12,5} \cdot t_{pl} = 6,65 \cdot t_{pl} \rightarrow t_{pl}^{\min} = 1 \text{ mm}$$

SAVIJANJE PLOČE OD VLAČNIH VIJAKA

$$M_{Sd} = F_{t,Sd} \cdot c = 18,95 \cdot 0,03 = 0,57 \text{ kNm}$$

$$t_{\min} = \sqrt{\frac{1,1 \cdot M_{Sd} \cdot 6}{b_{pl} \cdot f_y}} = \sqrt{\frac{1,1 \cdot 57 \cdot 6}{160 \cdot 23,5}} = 0,32 \text{ cm} \rightarrow 1,0 \text{ cm} = 10 \text{ mm}$$

$$t = 10 \text{ mm}$$

USVOJENE DIMENZIJE PLOČE: 160×215×10 mm

7.4 DIMANZIONIRANJE SPOJA SEKUNDARNE NA GLAVNU KONSTRUKCIJU

SPAJANJE KROVNE PODROŽNICE NA GORNJI POJAS GREDE

ULAZNI PODACI

$$N_{Ed} = 53,64 \text{ kN}$$

$$V_{z,Ed} = 1,34 \text{ kN}$$

$$V_{y,Ed} = 22,53 \text{ kN}$$

MATERIJAL

OSNOVNI MATERIJAL: S235

VIJCI k.v. 4.6; M - 12

$$h = 148 \text{ mm}$$

$$b = 160 \text{ mm}$$

$$t_f = 7 \text{ mm}$$

$$t_w = 5 \text{ mm}$$

$$r = 15 \text{ mm}$$

POPREČNI PRESJEK: HEA320

$$h = 310 \text{ mm}$$

$$b = 300 \text{ mm}$$

$$t_f = 16 \text{ mm}$$

$$t_w = 9 \text{ mm}$$

$$r = 27 \text{ mm}$$

OTPORNOST VIJKA NA VLAK

$$F_{t,RD} = \frac{F_{t,Rk}}{\gamma_{M1}} = \frac{30,3}{1,25} = 24,24 \text{ kN} > F_{t,ED} = \frac{22,53}{4} = 5,63 \text{ kN}$$

OTPORNOST VIJAKA NA POSMIK

$$F_{w,ED} = \sqrt{53,64^2 + 1,34^2} = 54,43 \text{ kN}$$

$$F_{v,Rd} = \frac{F_{v,Rk}}{\gamma_{M1}} = \frac{20,2}{1,25} = 16,16 \text{ kN} \geq \frac{F_{w,ED}}{4} = 13,61 \text{ kN}$$

SPAJANJE BOČNE PODROŽNICE NA STUP

ULAZNI PODACI

$$N_{Ed} = 1,63 \text{ kN}$$

$$V_{z,Ed} = 9,26 \text{ kN}$$

$$V_{y,Ed} = 12,03 \text{ kN}$$

MATERIJAL

OSNOVNI MATERIJAL: S235

VIJCI k.v. 4.6; M - 12

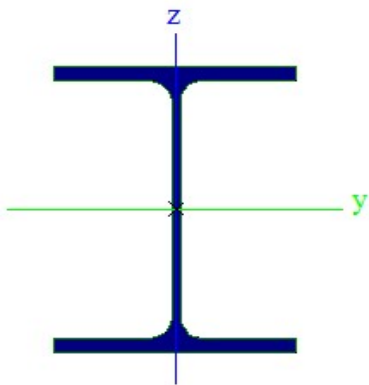

$$h = 148 \text{ mm}$$

$$b = 160 \text{ mm}$$

$$t_f = 7 \text{ mm}$$

$$t_w = 5 \text{ mm}$$

$$r = 15 \text{ mm}$$

POPREČNI PRESJEK: HEA320

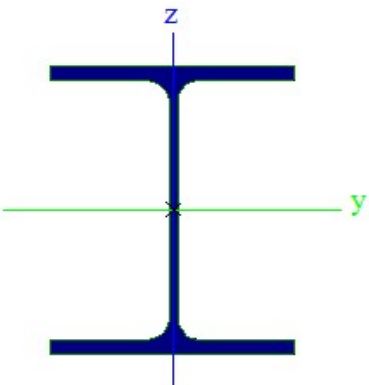

$$h = 310 \text{ mm}$$

$$b = 300 \text{ mm}$$

$$t_f = 16 \text{ mm}$$

$$t_w = 9 \text{ mm}$$

$$r = 27 \text{ mm}$$

OTPORNOST VIJKA NA VLAK

$$F_{t,RD} = \frac{F_{t,Rk}}{\gamma_{M1}} = \frac{30,3}{1,25} = 24,24 \text{ kN} > F_{t,ED} = \frac{9,26}{4} = 2,32 \text{ kN}$$

OTPORNOST VIJAKA NA POSMIK

$$F_{w,ED} = \sqrt{1,63^2 + 12,03^2} = 12,14 \text{ kN}$$
$$F_{v,Rd} = \frac{F_{v,Rk}}{\gamma_{M1}} = \frac{20,2}{1,25} = 16,16 \text{ kN} \geq \frac{F_{w,ED}}{4} = 3,03 \text{ kN}$$

7.5 DIMENZIONIRANJE SPOJA KROVNIH I BOČNIH SPREGOVA

KROVNI SPREG

ULAZNI PODACI

$$N_{Ed} = 32,44 \text{ kN}$$

Materijal:

Osnovni materijal: S235

Vijci: k.v. 10.9

Poprečni presjek:

Profil: Ø14

d= 14 mm

UVJET NOSIVOSTI NETO POPREČNOG PRESJEKA

$$A_{netto} = (2e_2 - d) \cdot t = (2 \cdot 25 - 13) \cdot 10 = 370 \text{ mm}^2$$

$$N_{u,RD} = \frac{0,9 \cdot A_{netto} \cdot f_u}{\gamma_{M2}} = \frac{0,9 \cdot 370 \cdot 360}{1,25} = 95,90 \text{ kN}$$

$$N_{ED} \leq N_{u,RD}$$

$$95,90 \text{ kN} < 32,44 \text{ kN}$$

UVJET NOSIVOSTI BRUTO POPREČNOG PRESJEKA

$$A_{brutto} = 50 \cdot 10 = 500 \text{ mm}^2$$

$$N_{pl,RD} = \frac{A_{brutto} \cdot f_y}{\gamma_{M2}} = \frac{500 \cdot 235}{1,25} = 94,0 \text{ kN}$$

$$N_{ED} \leq N_{pl,RD}$$

$$32,44 \text{ kN} < 94,0 \text{ kN}$$

OTPORNOST VIJAKA NA POSMIK

$$F_{v,Rd} = \frac{F_{v,Rk}}{\gamma_{M1}} = \frac{78,5}{1,25} = 62,80 \text{ kN} \geq F_{w,ED} = 32,44 \text{ kN}$$

OTPORNOST VIJKA NA PRITISAK PO OMOTAČU RUPE

$$F_{b,Rd} = \frac{F_{b,Rk}}{1,25} \cdot \frac{t_{pl}}{10} = \frac{83,1}{1,25} \cdot \frac{10}{10} = 66,48 \text{ kN} \geq F_{V,ED} = 32,44 \text{ kN}$$

KONTROLA VAROVA

$$a_{max} = 0,7 \cdot t_{min} = 0,7 \cdot 10 = 7 \text{ mm}$$

ZA PRETOPSTAVLJENI VAR a = 3 mm

$a = 3\text{mm}$, S235; $F_{w,Rk} = 181,9\text{ kN}$

$L_w = O = 4 \cdot 50 = 200\text{ mm}$

$$F_{w,Rd} = \frac{F_{w,Rk}}{1,25} \cdot \frac{L}{100} = \frac{77,9}{1,25} \cdot \frac{200}{100} = 124,64\text{ kN} > F_{w,ED} = 32,44\text{ kN}$$

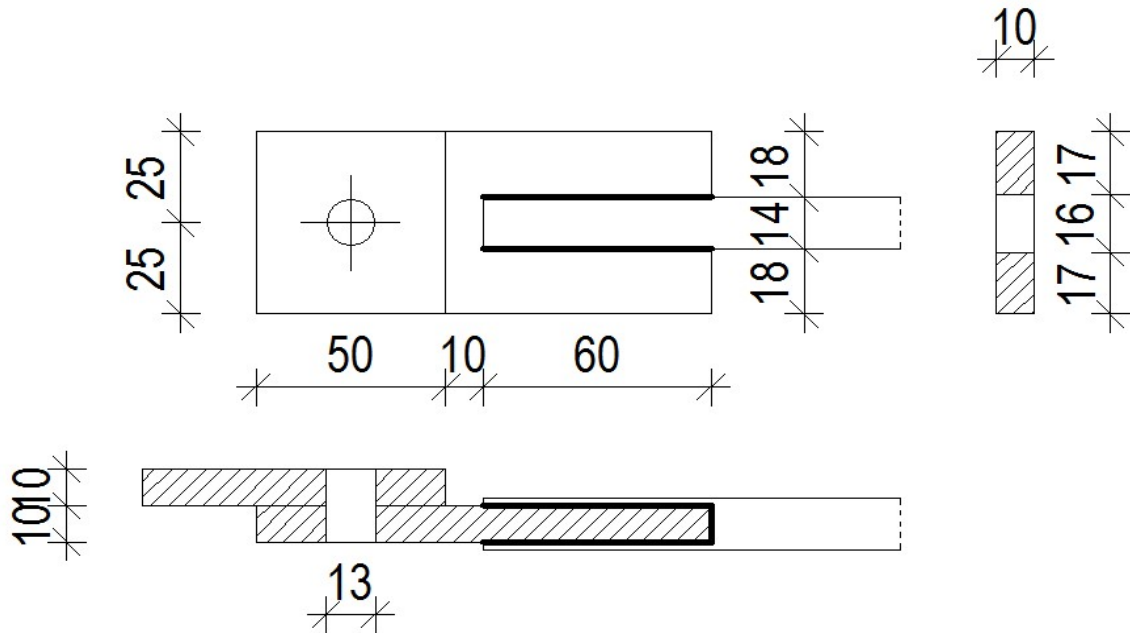

Slika 7.6.1 Detalj spoja krovnog sprega

BOČNI SPREG

ULAZNI PODACI

$$N_{Ed} = 56,93 \text{ kN}$$

Materijal:

Osnovni materijal: S235

Vijci: k.v. 10.9

Poprečni presjek:

Profil: Ø18

d= 18 mm

UVJET NOSIVOSTI NETO POPREČNOG PRESJEKA

$$A_{netto} = (2e_2 - d) \cdot t = (2 \cdot 25 - 13) \cdot 10 = 370 \text{ mm}^2$$

$$N_{u,RD} = \frac{0,9 \cdot A_{netto} \cdot f_u}{\gamma_{M2}} = \frac{0,9 \cdot 370 \cdot 360}{1,25} = 95,90 \text{ kN}$$

$$N_{ED} \leq N_{u,RD}$$

$$95,90 \text{ kN} < 56,93 \text{ kN}$$

UVJET NOSIVOSTI BRUTO POPREČNOG PRESJEKA

$$A_{brutto} = 50 \cdot 10 = 600 \text{ mm}^2$$

$$N_{pl,RD} = \frac{A_{brutto} \cdot f_y}{\gamma_{M2}} = \frac{500 \cdot 235}{1,25} = 94,0 \text{ kN}$$

$$N_{ED} \leq N_{pl,RD}$$

$$56,93 \text{ kN} < 94,0 \text{ kN}$$

OTPORNOST VIJAKA NA POSMIK

$$F_{v,Rd} = \frac{F_{v,Rk}}{\gamma_{M1}} = \frac{78,5}{1,25} = 62,80 \text{ kN} \geq F_{w,ED} = 56,93 \text{ kN}$$

OTPORNOST VIJKA NA PRITISAK PO OMOTAČU RUPE

$$F_{b,Rd} = \frac{F_{b,Rk}}{1,25} \cdot \frac{t_{pl}}{10} = \frac{83,1}{1,25} \cdot \frac{10}{10} = 66,48 \text{ kN} \geq F_{V,ED} = 56,93 \text{ kN}$$

KONTROLA VAROVA

$$a_{max} = 0,7 \cdot t_{min} = 0,7 \cdot 10 = 7 \text{ mm}$$

ZA PRETOPSTAVLJENI VAR a = 3 mm

$a = 3\text{mm}$, S235; $F_{w,Rk} = 181,9\text{ kN}$

$L_w = O = 4 \cdot 50 = 200\text{ mm}$

$$F_{w,Rd} = \frac{F_{w,Rk}}{1,25} \cdot \frac{L}{100} = \frac{77,9}{1,25} \cdot \frac{200}{100} = 124,64\text{ kN} > F_{w,ED} = 56,93\text{ kN}$$

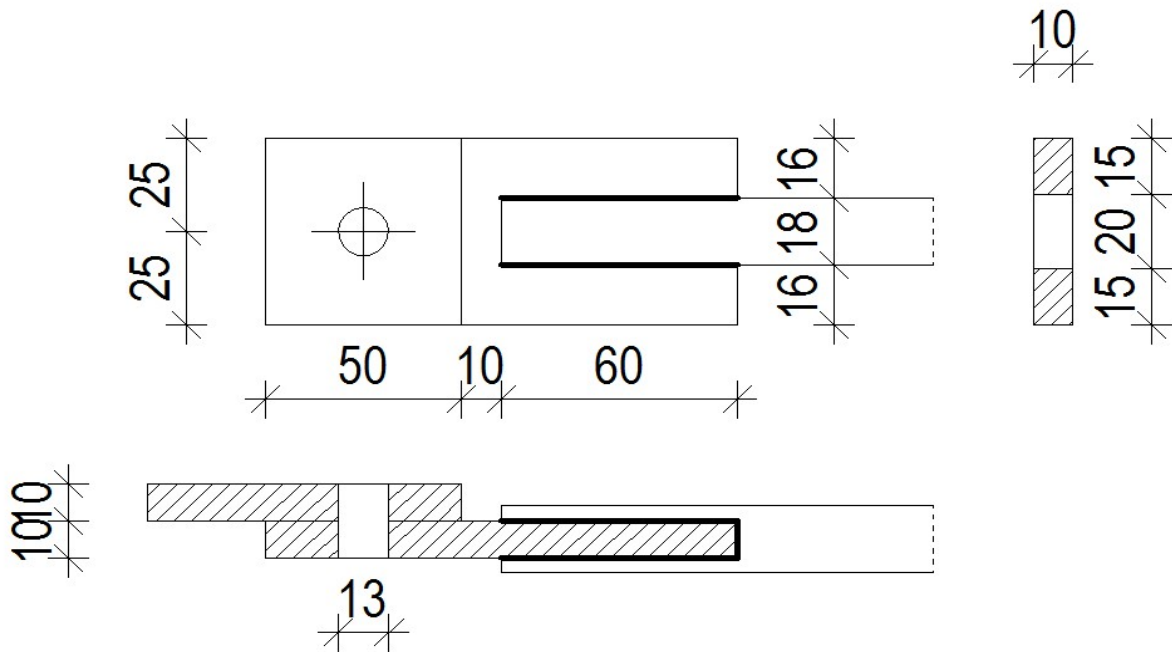

Slika 7.6.2 Detalj spoja bočnog sprega

8. PRORAČUN TEMELJA

ODABRANE DIMENZIJE TEMELJA

$$L = 2,5 \text{ m}$$

$$B = 2,5 \text{ m}$$

$$H = 1,5 \text{ m}$$

MATERIJAL:

TEMELJNO TLO:

$$\sigma_{tla,lim} = 300 \text{ kN/m}^2$$

BETON C25/30

$$f_{ck} = 25 \text{ kN/m}^2$$

ČELIK B500B

$$f_{yk} = 50 \text{ kN/m}^2$$

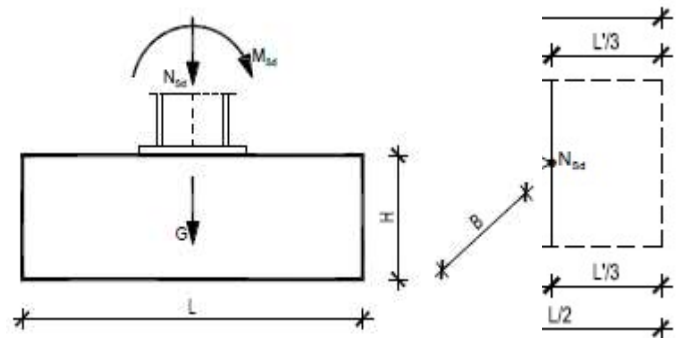

REZNE SILE

$$N_{Ed} = 137,48 \text{ kN (TLAK)}$$

$$M_{Ed} = 241,09 \text{ kNm}$$

$$V_{Ed} = 71,69 \text{ kN}$$

POVRŠINA TEMELJNE STOPE

$$A = L \cdot B = 2,5 \cdot 2,5 = 6,25 \text{ m}^2$$

TEŽINA TEMELJNE STOPE

$$G = L \cdot B \cdot H \cdot \gamma_b = 2,5 \cdot 2,5 \cdot 1,5 \cdot 25 = 234,38 \text{ kN}$$

MOMENT OTPORA

$$W = \frac{B \cdot L^2}{6} = \frac{2,5 \cdot 2,5^2}{6} = 2,60 \text{ m}^3$$

NAPREZANJE U TLU ISPOD TEMELJNE STOPE NA DUBINI TEMELJENJA

$$\sigma_{1,2} = \frac{G + N_{SD}}{A} \pm \frac{M_{SD}}{W} = \frac{234,38 + 137,48}{6,25} \pm \frac{241,09}{2,6} = 59,5 \pm 92,73$$

$$\sigma_1 = 152,23 \text{ kN/m}^2$$

$$\sigma_2 = -33,23 \text{ kN/m}^2$$

$$e = \frac{M_{SD}}{G + N_{SD}} = \frac{241,09}{234,38 + 137,48} = 0,65 \text{ m}$$

$$\frac{L}{2} = e + \frac{L'}{3} \rightarrow L' = 3 \left(\frac{L}{2} - e \right) = 3 \left(\frac{2,5}{2} - 0,65 \right) = 1,8 \text{ m}$$

$$\sigma_{ekv} = \frac{2 \cdot (G + N_{SD})}{L' \cdot B} = \frac{2 \cdot (234,38 + 137,48)}{1,8 \cdot 2,5} = 165,27 \text{ kN/m}^2 < \sigma_{tla,lim} = 300 \text{ kN/m}^2$$

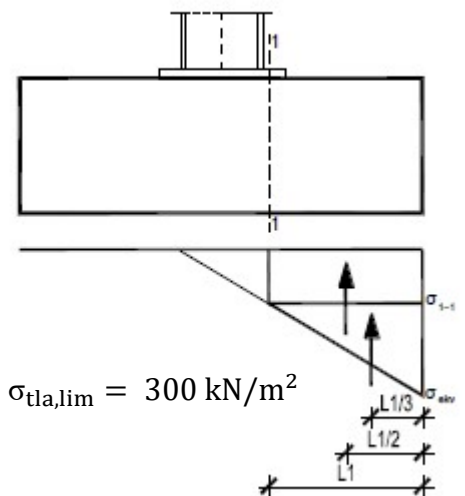

PRORAČUN ARMATURE TEMELJA

$$L_1 = \frac{L - h_{\text{stup}}}{2} = \frac{2,5 - 0,31}{2} = 1,095 \text{ m}$$

$$\frac{\sigma_{1-1}}{L' - L_1} = \frac{\sigma_{ekv}}{L'} \rightarrow \sigma_{1-1} = \frac{L' - L_1}{L'} \cdot \sigma_{ekv} = \frac{1,8 - 1,095}{1,8} \cdot 165,27 = 64,73 \text{ kN/m}^2$$

$$M_{SD}^{1-1} = \gamma \cdot \left(\sigma_{1-1} \cdot \frac{L_1^2}{2} \cdot B + \frac{\sigma_{ekv} - \sigma_{1-1}}{2} \cdot L_1 \cdot B \cdot \frac{2}{3} \cdot L_1 \right)$$

$$M_{SD}^{1-1} = 1,4 \cdot \left(64,73 \cdot \frac{1,095^2}{2} \cdot 2,5 + \frac{165,27 - 64,73}{2} \cdot 1,095 \cdot 2,5 \cdot \frac{2}{3} \cdot 1,095 \right) = 276,46 \text{ kNm}$$

KRAK UNUTARNJIH SILA U BETONU

$$z \approx 0,8H = 0,8 \cdot 1,5 = 1,2 \text{ m}$$

POTREBNA POVRŠINA ARMATURE

$$A_{s1} = \frac{M_{SD}^{1-1}}{z \cdot f_{yk} / \gamma_s} = \frac{27646}{120 \cdot 50,0 / 1,15} = 5,3 \text{ cm} < A_{s1,min} = \frac{0,1}{100} \cdot B \cdot H = 37,5 \text{ cm}$$

ODABRANA ARMATURA:

GLAVNA ARMATURA – $\phi 20/10$	12 KOMADA	$A_s = 37,7 \text{ cm}^2$
POMOĆNA ARMATURA – $\phi 8/25$	12 KOMADA	$A_s = 37,7 \text{ cm}^2$

9. LITERATURA

[1] B. Androić; D. Dumović; I. Džeba: Metalne konstrukcije 1, Institut građevinarstva Hrvatske, Zagreb, 1994.

[2] B. Androić; D. Dumović; I. Džeba: Metalne konstrukcije 2, Institut građevinarstva Hrvatske, Zagreb, 1994.

[3] B. Androić; D. Dumović; I. Džeba: Metalne konstrukcije 3, Institut građevinarstva Hrvatske, Zagreb, 1994

[4] ENV 1993-1-1: 1992: Eurocode 3: Bemessung nach EC3, Bemessung und Konstruktion von Stahlbauten – Teil 1-1: Allgemeine Bemessungsregeln, Bemessungsregeln für den Hochbau.

[5] Prof.dr sc. Ivica Boko: Predavanja

10. NACRTI

GENERALNI PLAN POZICIJA M 1:200

TLOCRT

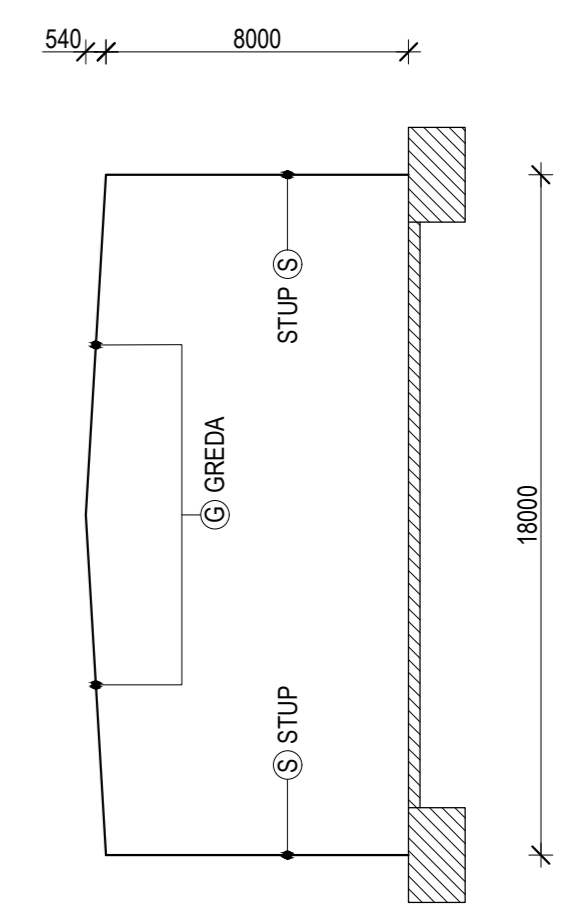
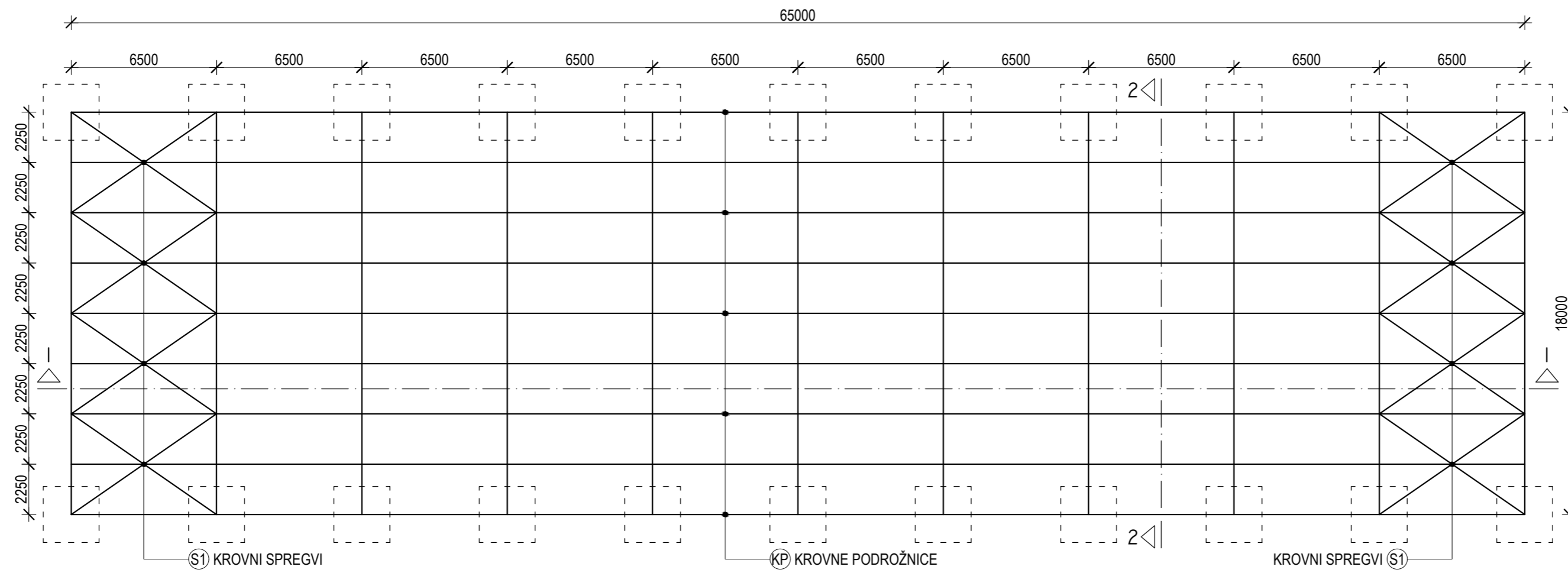

PRESJEK 1-1

PRESJEK 2-2

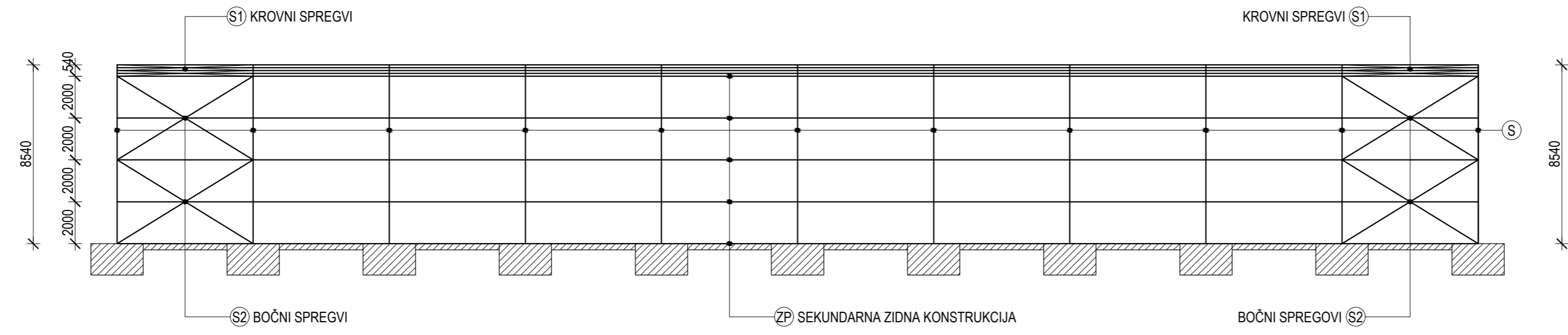

<p>FAKULTET GRAĐEVINARSTVA, ARHITEKTURE I GEODEZIJE Matije hrvatske 15</p>	METALNE KONSTRUKCIJE	
	TEMA: ANALIZA UTROŠKA MATERIJALA ČELIČNE HALE	
	STUDENT: VRKIĆ JOSIP, 4654	M 1:200
	SADRŽAJ: GENERALNI PLAN POZICIJA	BROJ PRILOGA: 1
DATUM: Rujan 2019.		

PRESJEK KROZ GLAVNI OKVIR

M 1:50

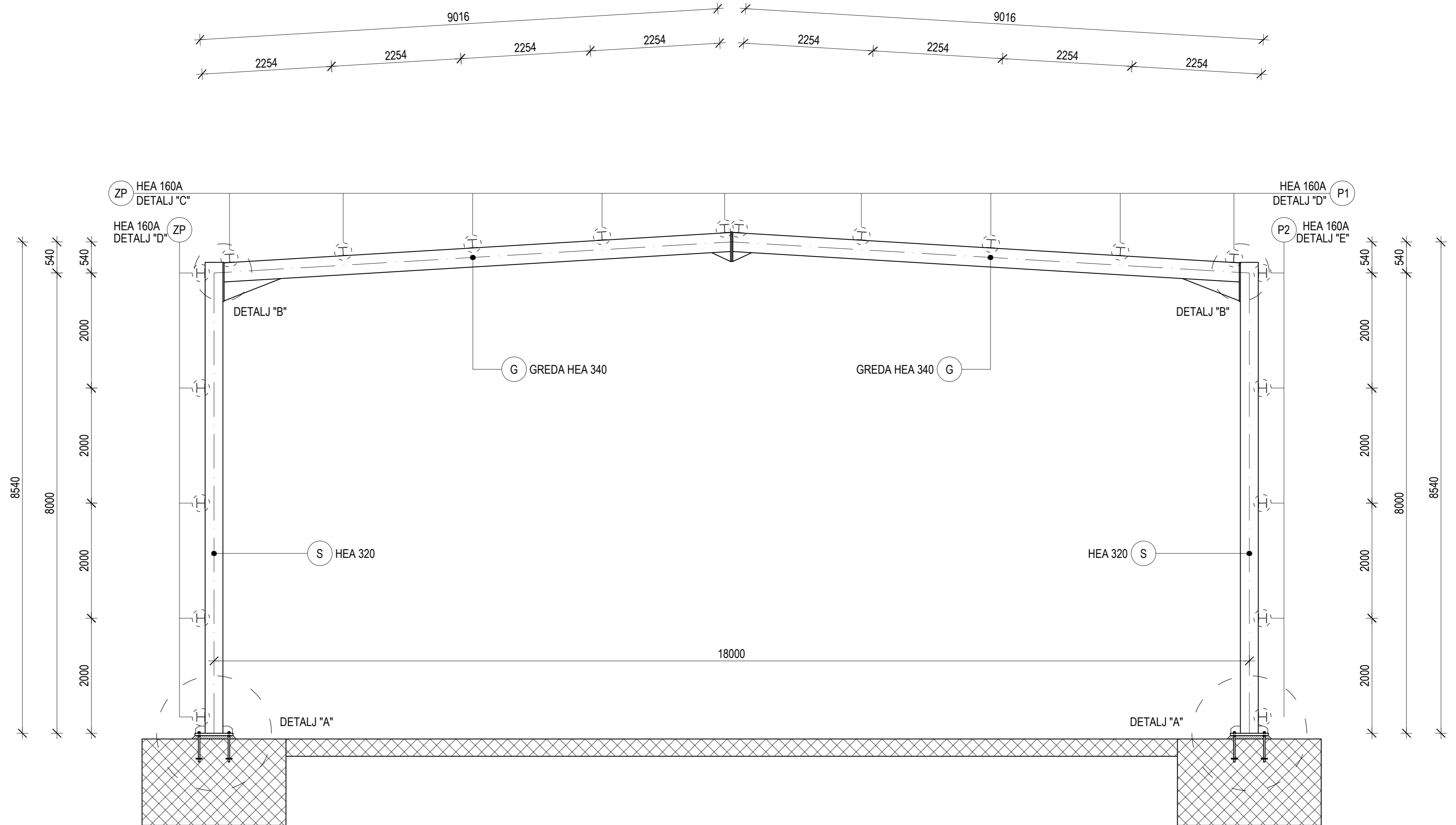

PRODUCED BY AN AUTODESK STUDENT VERSION

PRODUCED BY AN AUTODESK STUDENT VERSION

	METALNE KONSTRUKCIJE	
	TEMA: ANALIZA UTROŠKA MATERIJALA ČELIČNE HALE	
	STUDENT: VRKIĆ JOSIP, 4654	M 1:50
	SADRŽAJ: PRESJEK KROZ GLAVNI OKVIR	BROJ PRILOGA: 2
DATUM: Rujan 2019.		

GLAVNA KONSTRUKCIJA

STUP S; HEA320; L=8186 mm; kom 22

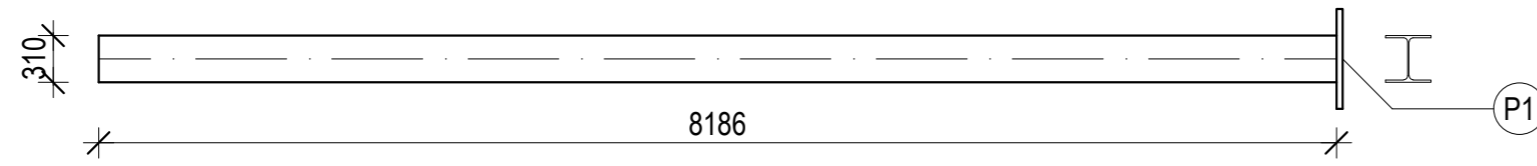

GREDA G; HEA 340; L=8841 mm; kom 22

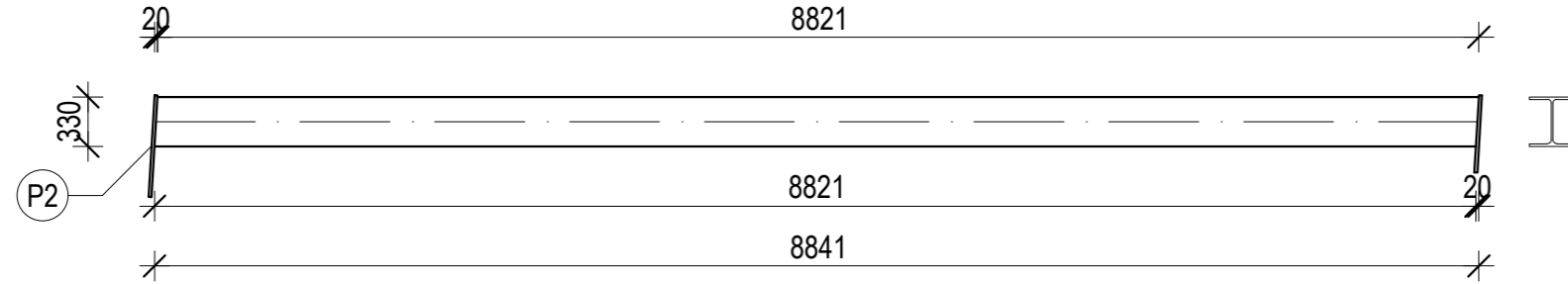

SEKUNDARNA KONSTRUKCIJA

KROVNI SEKUNDARNI NOSAČ KP1; HEA 160A; L=9740 mm; kom 20

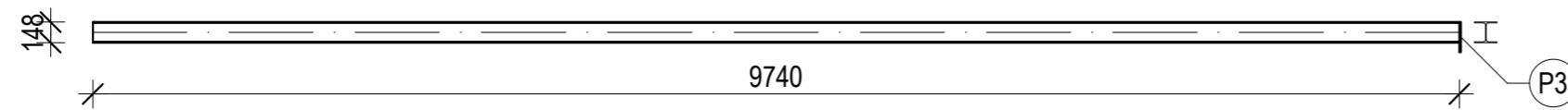

KROVNI SEKUNDARNI NOSAČ P2; HEA 160A; L=6480 mm; kom 70

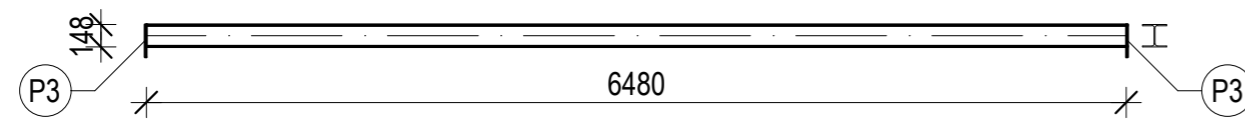

BOČNI SEKUNDARNI NOSAČ ZP1; HEA 160A; L=9740 mm; kom 20

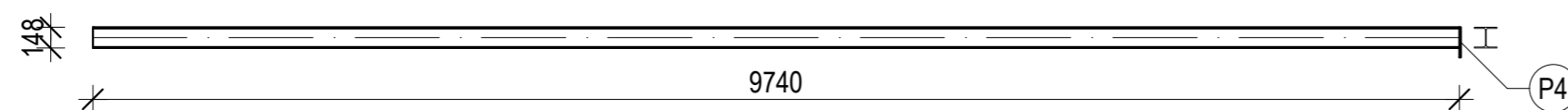

BOČNI SEKUNDARNI NOSAČ ZP2; HEA 160A; L=6480 mm; kom 70

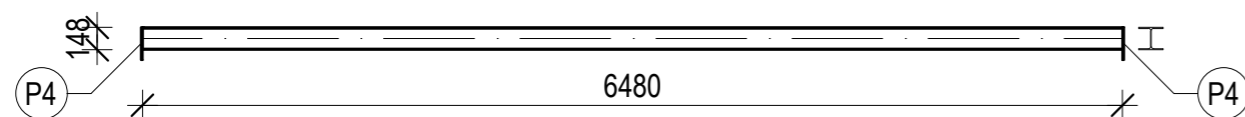

RADIONIČKI NACRT GLAVNOG OKVIRA M 1:50

SPREGOVI

KROVNI SPREG S1; RD 14; L=7905 mm; kom 16

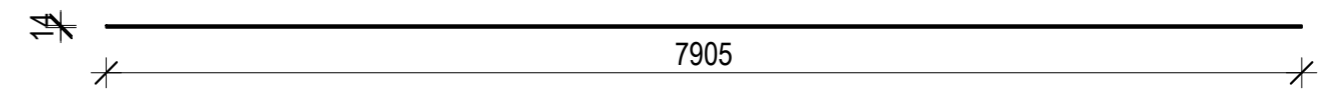

BOČNI SPREG S2; RD 18; L=7632 mm; kom 16

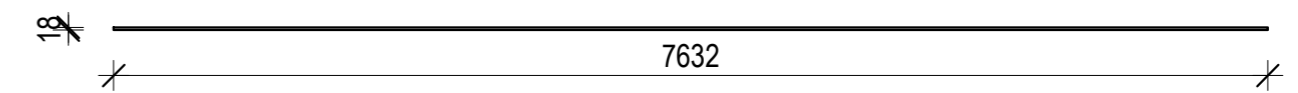

	METALNE KONSTRUKCIJE	
	TEMA: ANALIZA UTROŠKA MATERIJALA ČELIČNE HALE	
	STUDENT: VRKIĆ JOSIP, 4654	M 1:50
	SADRŽAJ: RADIONIČKI NACRT GLAVNOG OKVIRA	BROJ PRILOGA: 3
DATUM: Rujan 2019.		

PRIKAZ PLOČICA M 1:10

PLOČA P1; 600×340×40; kom 22

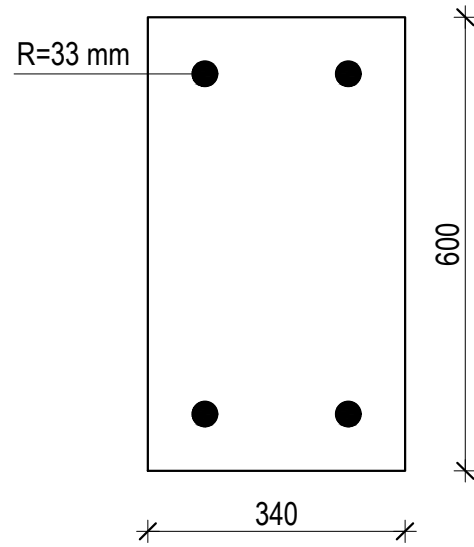

PLOČA P3; 215×160×10; kom 160

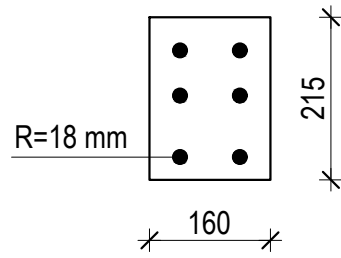

PLOČA P4; 215×160×10; kom 160

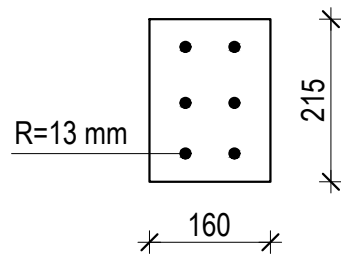

PLOČA P2; 680×320×20; kom 22

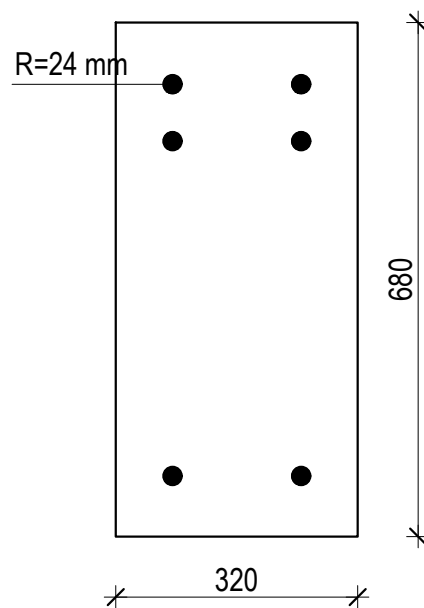

UKRUTA U1; 125×125×9; kom 44

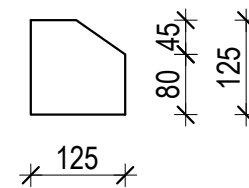

UKRUTA U2; 296×145×10; kom 44

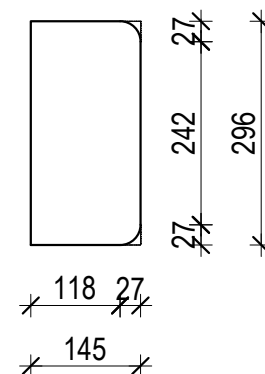

UKRUTA U3

PLOČA U3A; 960×313×10; kom 22

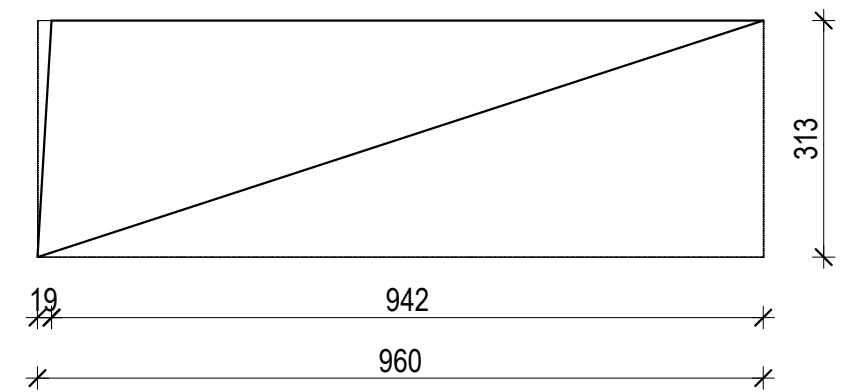

PLOČA U3B; 1062×300×15; kom 22

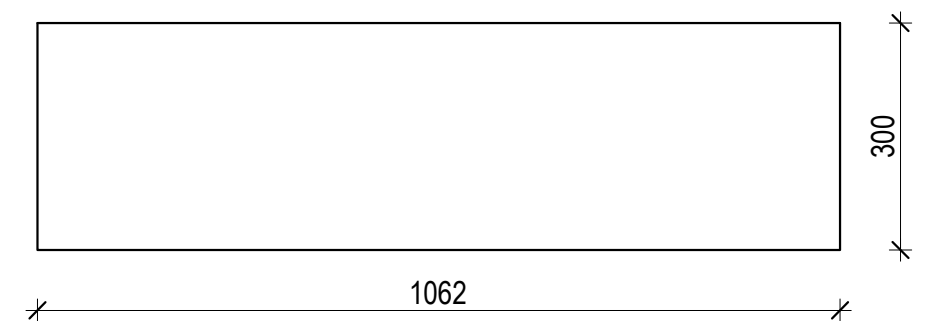

 FAKULTET GRAĐEVINARSTVA, ARHITEKTURE I GEODEZIJE Matice hrvatske 15	METALNE KONSTRUKCIJE	
	TEMA: ANALIZA UTROŠKA MATERIJALA ČELIČNE HALE	
	STUDENT: VRKIĆ JOSIP, 4654	M 1:10
	SADRŽAJ: PRIKAZ PLOČICA	BROJ PRILOGA:
	DATUM: Rujan 2019.	4

PRODUCED BY AN AUTODESK STUDENT VERSION

PRODUCED BY AN AUTODESK STUDENT VERSION

TABLICA PREDMJERA ZA CIJELU KONSTRUKCIJU					
POZICIJA	PROFIL	DUŽINA (mm)	KOMADA	JED. TEŽINA (kg/m)	UKUPNA TEŽINA (kg)
STUP	HEA 320	8186	22	97,34	17530,2
GREDA	HEA 340	8841	22	105,19	20459,7
KROVNA PODROŽNICA KP1	HEA 160A	9740	20	23,86	4648,7
KROVNA PODROŽNICA KP2	HEA 160A	6480	70	23,86	10824,7
BOČNA PODROŽNICA ZP1	HEA 160A	9740	20	23,86	4648,7
BOČNA PODROŽNICA ZP2	HEA 160A	6480	70	23,86	10824,7
KROVNI SPREG S1	RD 14	7905	16	1,21	152,8
BOČNI SPREG S2	RD 18	7632	16	2,00	243,8
PLOČA P1	600×340×40	-	22	-	1409,232
PLOČA P2	680×320×20	-	22	-	78,64758
PLOČA P3	215×160×10	-	160	-	432,064
PLOČA P4	215×160×10	-	160	-	432,064
PLOČA U3A	960×313×10	-	22	-	518,929
PLOČA U3B	1062×300×15	-	22	-	825,3333
UKRUTA U1	125×125×9	-	44	-	48,57188
UKRUTA U2	296×145×15	-	44	-	222,3685
				Σ	73300,4
				2% SPOJNA SREDSTVA	1466,009
				UKUPNO (kg)	74766,4

 <p>FAKULTET GRAĐEVINARSTVA, ARHITEKTURE I GEODEZIJE Matice hrvatske 15</p>	METALNE KONSTRUKCIJE	
	TEMA: ANALIZA UTROŠKA MATERIJALA ČELIČNE HALE	
	STUDENT: VRKIĆ JOSIP, 4654	
	SADRŽAJ: ISKAZ MATERIJALA	
	DATUM: Rujan 2019.	
		BROJ PRILOGA: 5

DETALJ "A" SPOJ STUP - TEMELJ

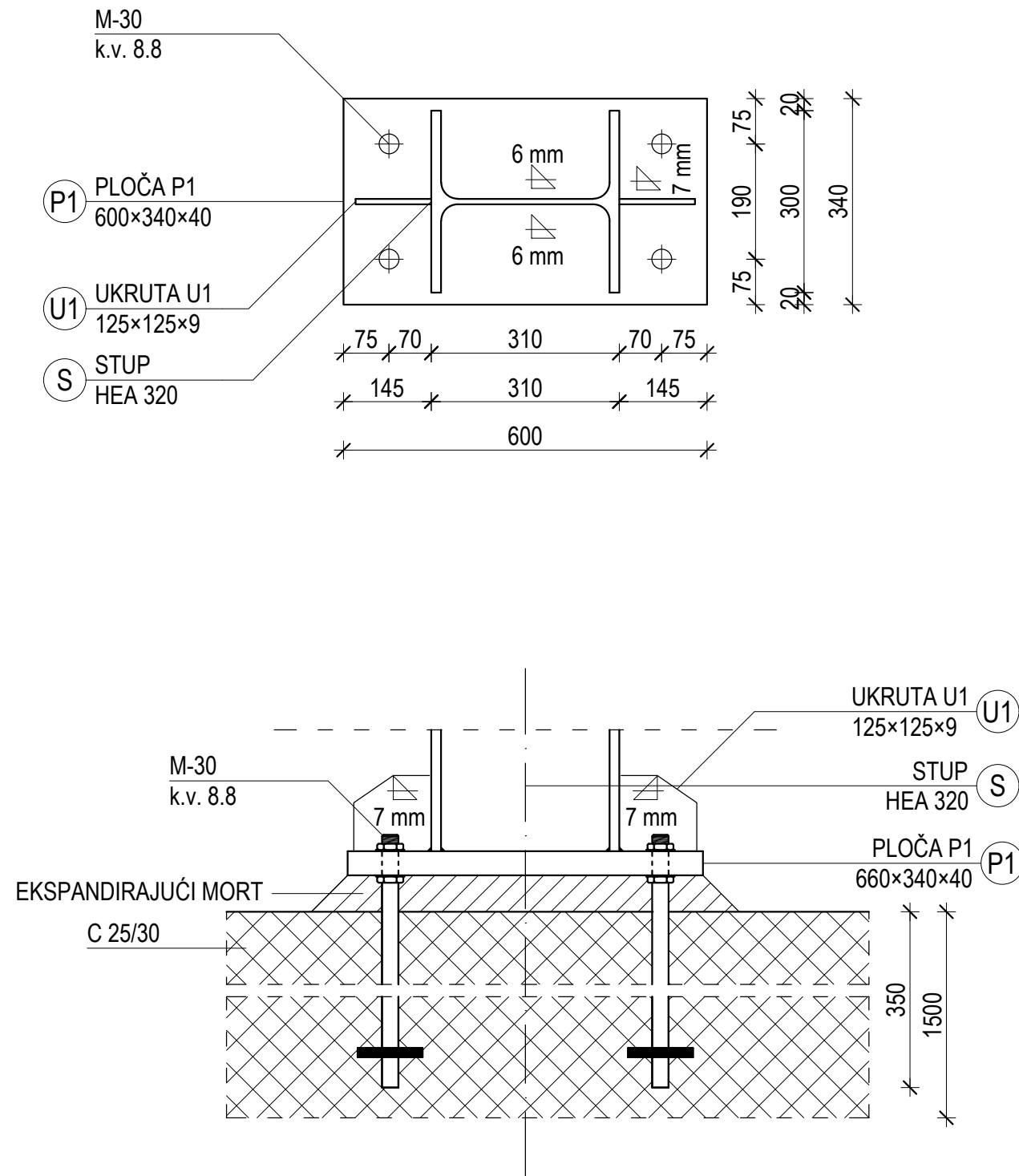

DETALJI SPOJEVA M 1:10

DETALJ "F" NASTAVAK BOČNE PODROŽNICE

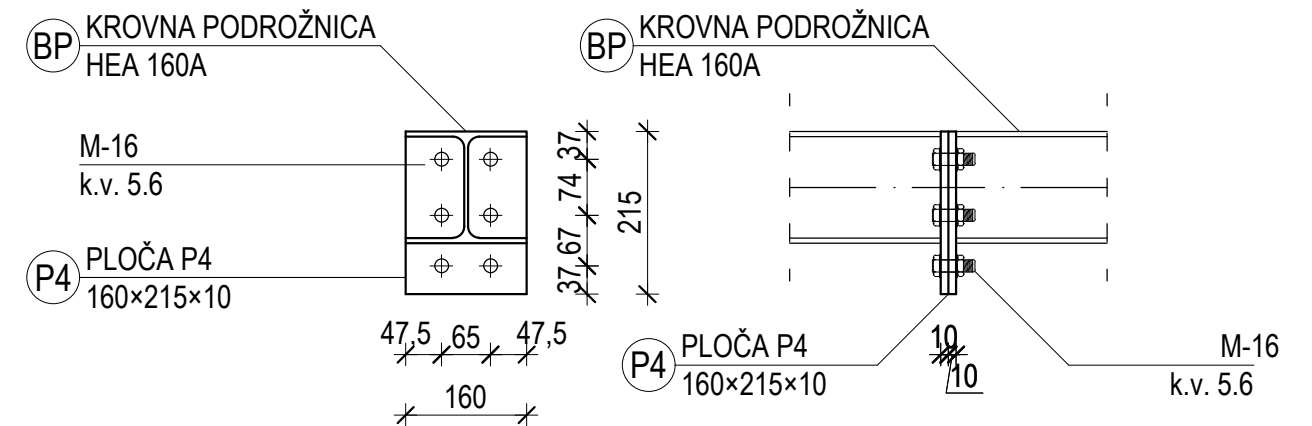

 <p>FAKULTET GRAĐEVINARSTVA, ARHITEKTURE I GEODEZIJE Matice hrvatske 15</p>	METALNE KONSTRUKCIJE	
	TEMA: ANALIZA UTROŠKA MATERIJALA ČELIČNE HALE	
	STUDENT: VRKIĆ JOSIP, 4654	M 1:10
	SADRŽAJ: DETALJI SPOJEVA	BROJ PRILOGA: 6
	DATUM: Rujan 2019.	

DETALJ "B" SPOJ STUP - GREDA

DETALJI SPOJEVA M 1:10

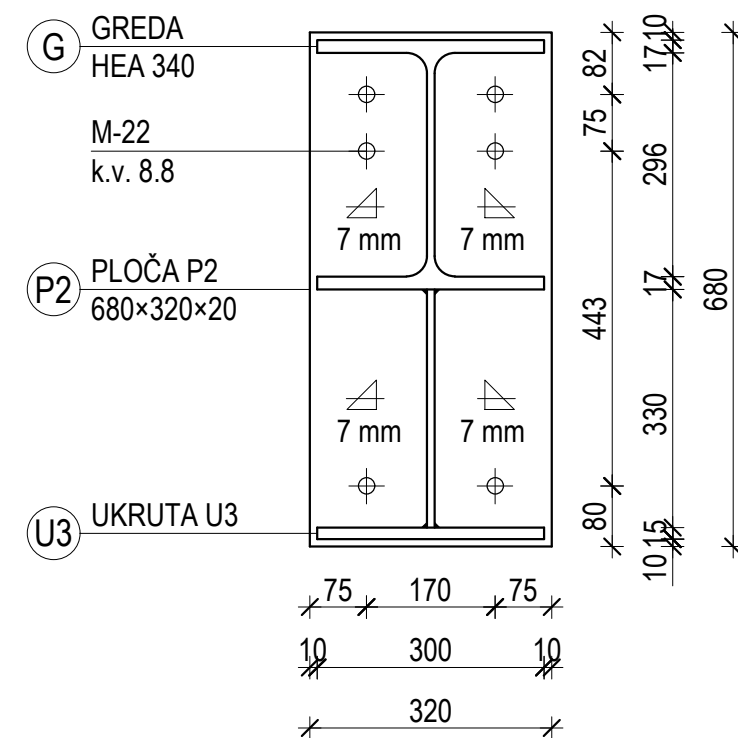
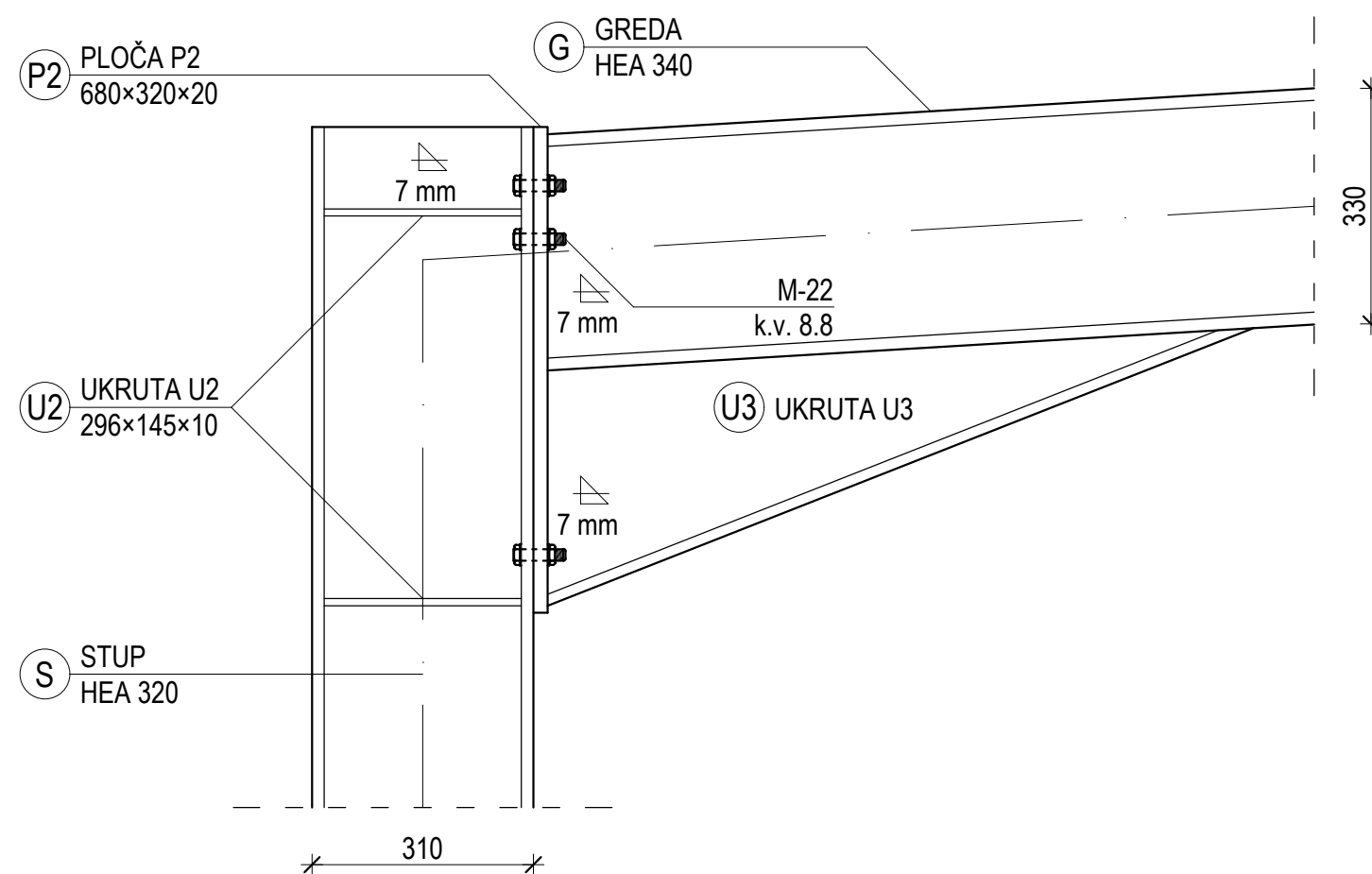

	METALNE KONSTRUKCIJE	
	TEMA: ANALIZA UTROŠKA MATERIJALA ČELIČNE HALE	
	STUDENT: VRKIĆ JOSIP, 4654	M 1:10
	SADRŽAJ: DETALJI SPOJEVA	BROJ PRILOGA:
	DATUM: Rujan 2019.	7

DETALJ "C"

SPOJ KROVNE PODROŽNICE I GREDE

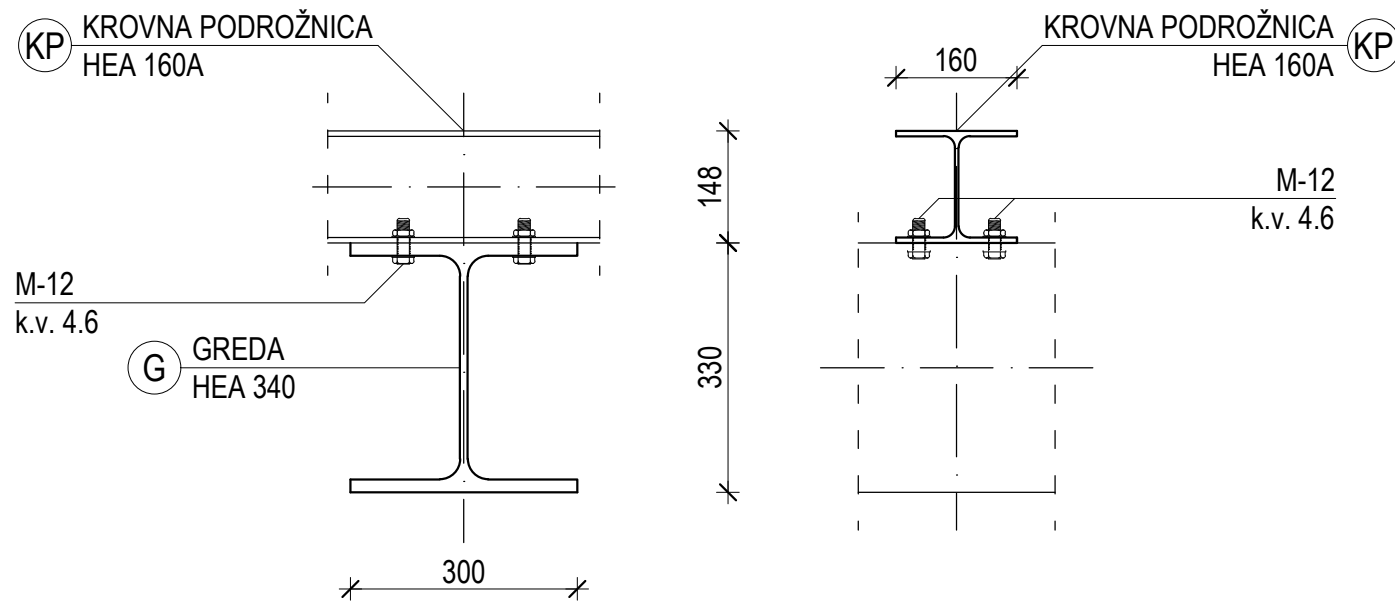

DETALJI SPOJEVA

M 1:10

DETALJ "E"

NASTAVAK KROVNE PODROŽNICE

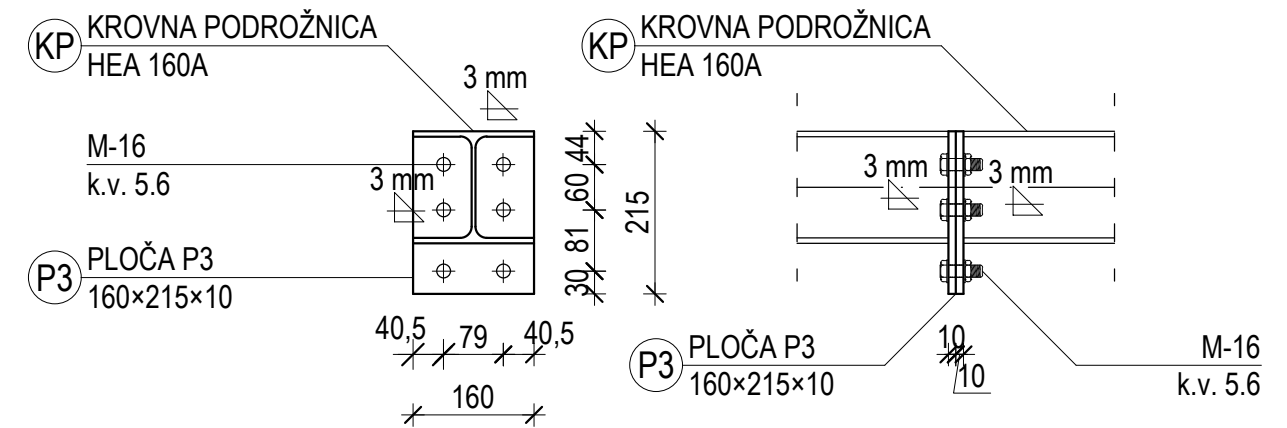

DETALJ "D"

SPOJ BOČNE PODROŽNICE I STUPA

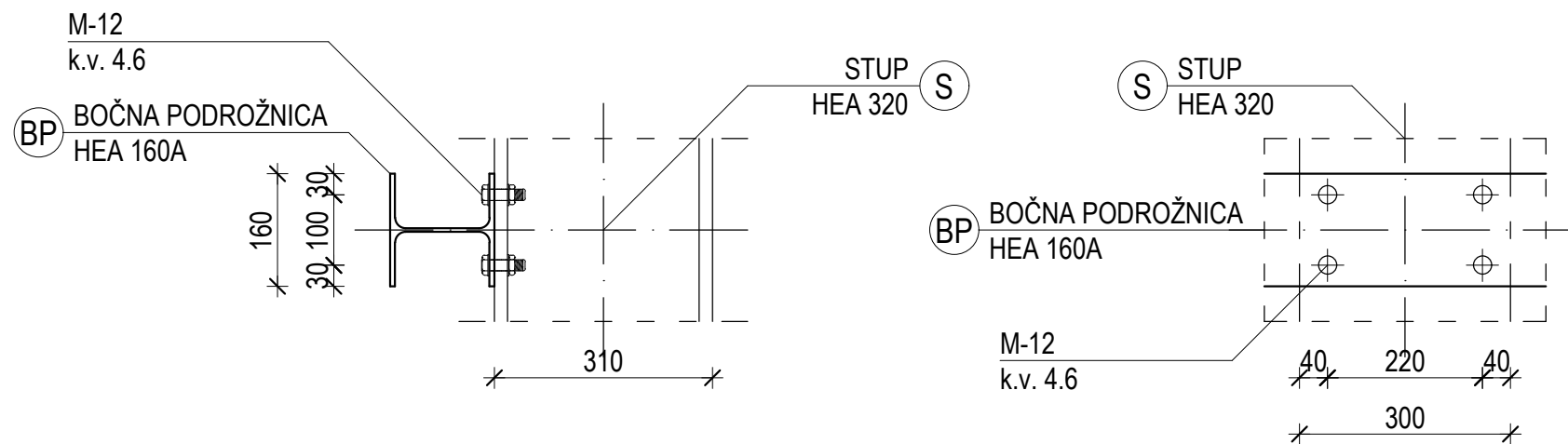

	METALNE KONSTRUKCIJE	
	TEMA: ANALIZA UTROŠKA MATERIJALA ČELIČNE HALE	
	STUDENT: VRKIĆ JOSIP, 4654	M 1:10
	SADRŽAJ: DETALJI SPOJEVA	BROJ PRILOGA:
	DATUM: Rujan 2019.	8

PRODUCED BY AN AUTODESK STUDENT VERSION

PRODUCED BY AN AUTODESK STUDENT VERSION