

Proračun nosive konstrukcije zidane građevine

Vrdoljak, Petar

Undergraduate thesis / Završni rad

2023

Degree Grantor / Ustanova koja je dodijelila akademski / stručni stupanj:

University of Split, Faculty of Civil Engineering, Architecture and Geodesy / Sveučilište u Splitu, Fakultet građevinarstva, arhitekture i geodezije

Permanent link / Trajna poveznica: <https://um.nsk.hr/um:nbn:hr:123:340105>

Rights / Prava: [In copyright](#)/[Zaštićeno autorskim pravom.](#)

Download date / Datum preuzimanja: **2025-03-22**



Repository / Repozitorij:

[FCEAG Repository - Repository of the Faculty of Civil Engineering, Architecture and Geodesy, University of Split](#)



UNIVERSITY OF SPLIT



**SVEUČILIŠTE U SPLITU
FAKULTET GRAĐEVINARSTVA, ARHITEKTURE I GEODEZIJE**

ZAVRŠNI RAD

Petar Vrdoljak

Split, 2022./2023.

**SVEUČILIŠTE U SPLITU
FAKULTET GRAĐEVINARSTVA, ARHITEKTURE I GEODEZIJE**

Proračun nosive konstrukcije zidane građevine

Završni rad

Split, 2022./2023.

Sažetak:

U radu je prikazan proračun zidane konstrukcije. Konstrukcija se sastoji od 3 etaže, prizemlja i 2 kata. Proračun sadrži dokaz nosivosti zidova na vertikalna opterećenja, dokaz nosivosti zidova na potres, određivanje širine temeljnih traka iz uvjeta nosivosti, proračun međukatnih konstrukcija i određivanje potrebne armature.

Ključne riječi:

zidana konstrukcija, zide, zid, međukatna konstrukcija, temelj, armatura, opterećenje, potres

Calculation of the load bearing masonry structure

Abstract:

The calculation of the masonry structure is presented in the paper. The construction consists of three floors, ground floor and two floors. The calculation contains proof of the bearing capacity of the walls against vertical loads, proof of the bearing capacity of the walls against an earthquake, determination of the width of the foundation strips from the bearing conditions, calculation of the inter-floor constructions and determination of the required reinforcement.

Keywords:

masonry structure, walls, wall, floor structure, foundation, reinforcement, load, earthquake

SVEUČILIŠTE U SPLITU
FAKULTET GRAĐEVINARSTVA, ARHITEKTURE I GEODEZIJE

Split, Matice hrvatske 15

STUDIJ: **PREDDIPLOMSKI STRUČNI STUDIJ**
GRAĐEVINARSTVA

KANDIDAT: Petar Vrdoljak

MATIČNI BROJ (JMBAG): 0083224085

KATEDRA: **Katedra za teoriju konstrukcija**

PREDMET: Zidane konstrukcije

ZADATAK ZA ZAVRŠNI RAD

Tema: proračun nosive konstrukcije zidane građevine

Opis zadatka: Potrebno je izraditi proračun nosive konstrukcije zidane zgrade. Nosiva konstrukcija je zidana i omeđena serklažama. 1. etaža međukatne konstrukcije je AB ploča, a 2. i 3. etaža su od sitno-rebrastih fert gredica. Građevina se nalazi u potresnoj zoni gdje se očekuje vršno ubrzanje podloge $a_g=0.23$ g s povratnim periodom od 475 godina. Proračunom je potrebno dokazati mehaničku otpornost i stabilnost konstrukcije. Proračun treba provesti prema europskim normama EC1, EC6 i EC8, te odgovarajućim hrvatskim normama i pravilnicima.

U Splitu, 13.07.2023.

Voditelj Završnog rada:

izv. prof. dr. sc. Hrvoje Smoljanović
izv. prof. dr. sc. Ivan Balić

Sadržaj

1. TEHNIČKI OPIS	1
1.1 Općenito	1
1.2 Opis nosive konstrukcije	1
1.2.1 Temelji	1
1.2.2 Zidovi	1
1.2.3 Međukatne konstrukcije	2
1.2.4 Ostale konstrukcije	2
1.3 Osnovna djelovanja i kombinacije	3
1.3.1 Osnovna djelovanja	3
1.3.2 Osnovne kombinacije djelovanja	4
2. PRORAČUN HORIZONTALNIH KONSTRUKCIJA	5
2.1 Ploče POZ 100 (a-b ploča)	5
2.1.1 Proračun armature u gredama	10
2.2 Ploča POZ 200 i POZ 300 (sitno rebrasti stropni sustav s gredicama)	20
3. PRORAČUN ZIDOVA	24
3.1 Proračun zidova na vertikalna opterećenja	24
3.1.1 Podaci za proračun zidova:	24
3.2 Proračun zidova na potres	31
3.2.1. Djelovanje potresa (S)	31
3.2.2. Kategorija temeljnog tla	32
3.2.3. Računsko ubrzanje tla	32
3.2.4. Proračun ukupne potresne poprečne sile	34
3.2.5. Proračun zidova na potres	38
4. PRORAČUN TEMELJA	50
5. LITERATURA	54
6. GRAĐEVINSKI NACRTI	55

1. TEHNIČKI OPIS

1.1 Općenito

Predmet ovog rada je proračun nosive konstrukcije stambene zgrade smještene u Splitu. Građevina je troetažna, pravilnog tlocrtnog oblika "sastavljenog" od dva spojena pravokutnika – pravokutnika dimenzija 6.70 x 8.90 m i pravokutnika dimenzija 3.40 x 10.60 m. Ukupna bruto površina građevine iznosi 287.79 m², a ukupna visina 8.60 m, mjereno od podne ploče prizemlja. Građevina se nalazi u potresnoj zoni gdje se očekuje vršno ubrzanje podloge $a_g=0.23$ g prema EC8 s povratnim periodom od 457 godina, te u II. području opterećenja vjetrom i području D opterećenja snijegom.

Međukatna konstrukcija iznad 1. etaže je armirano-betonska ploča, iznad 2. i 3. etaže je sitno rebrasti stropni sustav s prenapregnutim gredicama na dvije od tri pozicije i AB ploča na jednoj poziciji (pozicija sa stepeništem). Konstrukcija temelja je armiranobetonska, a sastoji se od: temeljnih traka, nad temeljnih zidova i podne ploče prizemlja.

1.2 Opis nosive konstrukcije

1.2.1 Temelji

Računska nosivost tla iznosi $\sigma_{R,d}=300$ kPa, što je nakon iskopa temelja potrebno utvrditi ispitivanjem. Temeljne trake izvesti (visine $h=50$) izvesti od betona C30/37, armirati s B-500. Nad temeljne zidove ($d=30$ cm) i podnu ploču ($d=15$ cm) izvesti od betona C30/37, armirati s B-500.

1.2.2 Zidovi

Nosive zidove zidati od blok opeke u vapneno-cementnom mortu (mort za opću namjenu). Zidovi su debljine $t=30$ cm, a omeđeni su vertikalnim i horizontalnim serklažama.

Svojstva blok opeke i morta:

- Grupa zidnih elemenata: 2
- Srednja tlačna čvrstoća bloka: $f_{b,min}=10.0$ N/mm²
- Razred izvedbe: 2
- Zidni elementi kategorije I.
- Propisani mort (mort zadanog sastava)

Za zidanje rabiti produžni mort marke M5 ($f_m=5.0 \text{ N/mm}^2$), kojemu odgovara slijedeći volumni sastav:

- cement : hidratizirano vapno : pijesak = 1 : ($\frac{1}{4}$ - $\frac{1}{2}$) : (4 - $4\frac{1}{4}$)

Obavezno je popunjavanje mortom horizontalnih i uspravnih sljubnica između zidnih blokova.

Po procjeni nadzornog inženjera utvrditi će se potreba za ispitivanjem tlačne čvrstoće morta.

1.2.3 Međukatne konstrukcije

Međukatnu konstrukciju iznad 1. etaže izvesti kao a-b ploču debljine 15 cm, od betona C25/30 i armirati s B-500. Horizontalne serklaže (b/h=30/30 cm) izvesti zajedno s pločom, od betona C25/30 i armirati s B-500.

Međukatnu konstrukciju iznad 2. i 3. etaže izvesti kao sitno rebrasti stropni sustav s pred napregnutim gredicama (osni razmak 60 cm) i opečnih blokova ispune (h=16 cm), monolitiziranu tlačnom a-b pločom (d=6 cm) armiranu s Q-188. Ukupna debljina konstrukcije je d=22.0 cm. Horizontalne serklaže izvesti u razini međukatnih konstrukcija od betona C25/30 i armirati s B-500.

1.2.4 Ostale konstrukcije

Vertikalne i horizontalne izbetonirati nakon zidanja ziđa. Moguće je ugraditi posebne blokove koji oblikuju oplatu serklaža. Horizontalne serklaže izvesti u razini međukatnih konstrukcija od betona C25/30 i armirati s B-500. serklaže izvesti od betona C25/30 i armirati s B-500. Sve vertikalne serklaže izbetonirati nakon zidanja ziđa. Horizontalne serklaže izvesti u razini međukatnih konstrukcija od betona C25/30 i armirati s B-500.

1.3 Osnovna djelovanja i kombinacije

1.3.1 Osnovna djelovanja

Osnovna djelovanja, na čiji utjecaj se dokazuje mehanička otpornost i stabilnost

predmetne građevine, podijeljena su prema slijedećem:

Oznaka osnovnog djelovanja	Opis djelovanja	
G	Stalno djelovanje. Vlastita težina elemenata nosive konstrukcije, obloga (podovi, žbuke), stalna oprema itd.	
Q1	Promjenjivo djelovanje: sobe, dnevni boravak, kuhinja,... stubište balkonske ploče	1.50 kN/m ² 3.00 kN/m ² 4.00 kN/m ²
Q2	Snijeg: područje opterećenja snijegom: nadmorska visina: karakteristična vrijednost snijega na tlu: opterećenje snijegom na krovu: $s = \mu_i C_e C_t s_k = 0.8 * 1.0 * 1.0 * 0.35$ Napomena: Za opterećenje krova mjerodavno je korisno opterećenje od	D ≤ 100 m.n.m. $s_k = 0.35$ kN/m ² $s = 0.28$ kN/m ² $q = 1.5$ kN/m ²
Q3	Vjetar: područje II. koeficijent položaja ($h \approx 10$ m, III. kategorija zemljišta): poredbeni tlak: $q_{ref} = \rho_{zraka} * v_{ref}^2 / 2 = 1.25 * (30^2) / 2 / 1000 =$ koeficijent vanjskog tlaka: $c_{pe} \approx 0.8$ koeficijent unutarnjeg tlaka: $c_{pi} \approx 0.3$ tlak vjetra na vanjske vertikalne površine: $w_e = q_{ref} * c_e(z) * c_{pe} = 0.56 * 2.0 * 0.8 =$ tlak vjetra na unutarnje vertikalne površine: $w_i = q_{ref} * c_e(z) * c_{pi} = 0.56 * 2.0 * 0.4 =$	$v_{ref,0} = 30$ m/s $c_e(z) = 2.0$ $q_{ref} = 0.56$ kN/m ² $w_e = 0.90$ kN/m ² $w_i = 0.45$ kN/m ²
S	Potres: računsko ubrzanje tla: razred tla: faktor ponašanja (za zidove): faktor važnosti građevine:	$a_g = 2.3$ m/s ² B 2.5 $\gamma_I = 1.0$

1.3.2 Osnovne kombinacije djelovanja

Granično stanje uporabljivosti :

Oznaka kombinacije	Parcijalni faktor za opterećenje	Koristi se za:	Parcijalni faktor za materijale
Gsu-1	osnovna kombinacija: 1.0G+1.0Q1	proračun progiba a-b ploča, kontrola naprezanja u tlu	ziđe: $\gamma_M=1.0$ beton: $\gamma_c=1.0$ čelik: $\gamma_s=1.0$

Granično stanje nosivosti :

Oznaka kombinacije	Parcijalni faktor za opterećenje	Koristi se za:	Parcijalni faktor za materijale
Gsn-1	osnovna kombinacija: 1.35G+1.5Q1	proračun ploča i zidova na vertikalna djelovanja	ziđe: $\gamma_M=2.2$ beton: $\gamma_c=1.5$ čelik: $\gamma_s=1.15$
Gsn-2	potres: 1.0G+1.0S+0.3Q1	proračun zidova na djelovanje potresa	ziđe: $\gamma_M=1.5$ beton: $\gamma_c=1.5$ čelik: $\gamma_s=1.15$

2. PRORAČUN HORIZONTALNIH KONSTRUKCIJA

2.1 Ploče POZ 100 (a-b ploča)

Opterećenje:

Stalno + dodatno stalno djelovanje:

pregradni zidovi	0.50 kN/m ²
završni sloj poda	0.50 kN/m ²
a-c estrih; d=6 cm; $\gamma=22$ kN/m ³	1.32 kN/m ²
<u>međukatna konstrukcija - a-b ploča; d=15 cm; $\gamma=25$ kN/m³</u>	<u>3.75 kN/m²</u>

ukupno stalno djelovanje: $g=6.07$ kN/m²

Promjenjivo djelovanje:

sobe, dnevni boravak, kuhinja,...: **$q=1.50$ kN/m²**

stubište: **$q=3.00$ kN/m²**

balkoni: **$q=4.00$ kN/m²**

Proračunski model ploče:

Poprečni presjek ploče



$h=15$ cm

zaštitni sloj: $a=a'=2.0$ cm
 $d=12.0$ cm

Beton: **C 30/37**

$f_{ck}=30.0$ MPa

$E_{cm}=32.8$ GPa

$\gamma_c=1.5$

Armatura: **B 500B**

$f_y=500$ MPa

$\gamma_s=1.15$

- ploča je modelirana plošnim elementima debljine $d=15$ cm
- ploča je slobodno oslonjena na zidove i horizontalne serklaže - beton: C25/30; armatura: B500; $E=30.5$ GPa

Limitirajući moment savijanja:

$$M_{Rd,lim} = 0.159 * (b * d^2) * f_{cd}$$

$$M_{Rd,lim} = 0.159 * (1.0 * 0.120^2) * (30/1.5) * 1000 = 45.8 \text{ kNm}$$

Min. i max. % armature za ploče:

$$A_{s,min} = 0.0015 * b * d = 0.0015 * 100 * 12.0 = 1.80 \text{ cm}^2/\text{m}$$

$$A_{s,min} = 0.6 * b * d / f_{yk} = 0.6 * 100 * 12.0 / 500 = 1.44 \text{ cm}^2/\text{m}$$

$$A_{s,max} = 0.31 * b * d * (f_{cd} / f_{yd}) = 0.31 * 100 * 12.0 * (30/1.5) / (500/1.15) = 17.11 \text{ cm}^2/\text{m}$$

Proračun armature:

Za proračun armature ploča usvaja se $\zeta \approx 0.9$. Potrebna armatura:

$$A_s = M_{Ed} * 100 / (\zeta * d * f_{yd}) = M_{Ed} * 100 / (0.9 * 12.0 * (50/1.15)) = M_{Ed} * 0.21$$

$$A_s = 0.21 * 1.35 * G + 0.21 * 1.5 * Q_1 = 0.28 * G + 0.32 * Q_1$$

-Prethodni izraz vrijedi za moment M_{Ed} u [kNm] i armaturu A_s u [cm²].

-Armaturu u polju zbog preraspodjele povećati 30 %.

$$M_x = k_x \cdot q \cdot l_x^2 \quad ; \quad M_x^a = k_x^a \cdot q \cdot l_x^2$$

$$M_y = k_y \cdot q \cdot l_y^2 \quad ; \quad M_y^b = k_y^b \cdot q \cdot l_y^2$$

q – jednoliko raspodijeljeno opterećenje
 Poissonov koeficijent = 0.15

upeti rub
 slobodno oslonjeni rui

Schema 1		Schema 2				
l_y/l_x	k_x	k_y	k_x	k_y	k_x^a	k_x^b
0.50	0.0079	0.0991	0.0084	0.0908	-0.0305	-0.1189
0.55	0.0103	0.0923	0.0109	0.0826	-0.0362	-0.1148
0.60	0.0131	0.0857	0.0135	0.0747	-0.0421	-0.1104
0.65	0.0162	0.0792	0.0162	0.0670	-0.0479	-0.1057
0.70	0.0194	0.0730	0.0192	0.0599	-0.0537	-0.1008
0.75	0.0230	0.0669	0.0221	0.0533	-0.0594	-0.0957
0.80	0.0269	0.0611	0.0249	0.0472	-0.0650	-0.0905
0.85	0.0307	0.0577	0.0277	0.0417	-0.0703	-0.0852
0.90	0.0344	0.0507	0.0304	0.0369	-0.0750	-0.0798
0.95	0.0383	0.0462	0.0330	0.0327	-0.0797	-0.0745
1.00	0.0423	0.0423	0.0354	0.0291	-0.0840	-0.0699
1.10	0.0500	0.0353	0.0399	0.0288	-0.0917	-0.0608
1.20	0.0575	0.0293	0.0438	0.0180	-0.0980	-0.0530
1.30	0.0644	0.0244	0.0471	0.0143	-0.1032	-0.0462
1.40	0.0710	0.0204	0.0500	0.0115	-0.1075	-0.0405
1.50	0.0722	0.0173	0.0524	0.0094	-0.1109	-0.0358
1.60	0.0825	0.0146	0.0544	0.0076	-0.1136	-0.0317
1.70	0.0874	0.0124	0.0561	0.0062	-0.1160	-0.0282
1.80	0.0916	0.0107	0.0572	0.0052	-0.1184	-0.0252
1.90	0.0954	0.0091	0.0586	0.0044	-0.1203	-0.0226
2.00	0.0991	0.0079	0.0594	0.0037	-0.1213	-0.0205
Množitelj	$q \cdot l_x^2$	$q \cdot l_y^2$	$q \cdot l_x^2$	$q \cdot l_y^2$	$q \cdot l_x^2$	$q \cdot l_y^2$

Schema 3		Schema 4				
l_y/l_x	k_x	k_y	k_x^a	k_x^b	k_y^a	k_y^b
0.50	0.0088	0.0835	-0.0297	0.0040	0.0670	-0.0205
0.55	0.0113	0.0738	-0.0350	0.0054	0.0643	-0.0249
0.60	0.0137	0.0647	-0.0400	0.0072	0.0614	-0.0294
0.65	0.0166	0.0563	-0.0450	0.0092	0.0483	-0.0341
0.70	0.0187	0.0489	-0.0497	0.0114	0.0451	-0.0390
0.75	0.0212	0.0423	-0.0540	0.0139	0.0418	-0.0442
0.80	0.0233	0.0363	-0.0578	0.0164	0.0385	-0.0496
0.85	0.0254	0.0313	-0.0612	0.0191	0.0354	-0.0548
0.90	0.0274	0.0270	-0.0644	0.0217	0.0324	-0.0598
0.95	0.0292	0.0232	-0.0677	0.0243	0.0295	-0.0648
1.00	0.0309	0.0201	-0.0699	0.0269	0.0269	-0.0699
1.10	0.0335	0.0151	-0.0741	0.0319	0.0221	-0.0787
1.20	0.0357	0.0113	-0.0770	0.0365	0.0182	-0.0869
1.30	0.0374	0.0088	-0.0793	0.0406	0.0148	-0.0937
1.40	0.0386	0.0068	-0.0811	0.0442	0.0122	-0.0993
1.50	0.0396	0.0053	-0.0815	0.0473	0.0100	-0.1041
1.60	0.0404	0.0042	-0.0825	0.0499	0.0081	-0.1082
1.70	0.0414	0.0034	-0.0830	0.0521	0.0066	-0.1116
1.80	0.0414	0.0028	-0.0832	0.0540	0.0055	-0.1143
1.90	0.0416	0.0023	-0.0833	0.0566	0.0046	-0.1167
2.00	0.0417	0.0019	-0.0833	0.0570	0.0040	-0.1189
Množ.	$q \cdot l_x^2$	$q \cdot l_y^2$	$q \cdot l_x^2$	$q \cdot l_y^2$	$q \cdot l_x^2$	$q \cdot l_y^2$

Schema 5		Schema 6				
l_y/l_x	k_x	k_y	k_x^a	k_x^b	k_y^a	k_y^b
0.50	0.0045	0.0650	-0.0203	-0.1135	0.0024	0.0405
0.55	0.0062	0.0514	-0.0247	-0.1078	0.0033	0.0394
0.60	0.0081	0.0476	-0.0291	-0.1021	0.0046	0.0378
0.65	0.0101	0.0436	-0.0336	-0.0964	0.0061	0.0360
0.70	0.0122	0.0398	-0.0381	-0.0906	0.0079	0.0339
0.75	0.0145	0.0369	-0.0427	-0.0845	0.0098	0.0315
0.80	0.0169	0.0323	-0.0471	-0.0781	0.0103	0.0293
0.85	0.0191	0.0289	-0.0513	-0.0720	0.0139	0.0269
0.90	0.0211	0.0257	-0.0551	-0.0661	0.0160	0.0247
0.95	0.0232	0.0228	-0.0586	-0.0603	0.0181	0.0224
1.00	0.0252	0.0202	-0.0617	-0.0546	0.0202	0.0202
1.10	0.0287	0.0158	-0.0676	-0.0467	0.0242	0.0164
1.20	0.0316	0.0123	-0.0722	-0.0399	0.0287	0.0131
1.30	0.0340	0.0095	-0.0757	-0.0341	0.0306	0.0105
1.40	0.0369	0.0075	-0.0782	-0.0293	0.0332	0.0084
1.50	0.0374	0.0060	-0.0800	-0.0254	0.0363	0.0066
1.60	0.0386	0.0048	-0.0814	-0.0221	0.0369	0.0053
1.70	0.0395	0.0039	-0.0825	-0.0193	0.0383	0.0042
1.80	0.0402	0.0031	-0.0834	-0.0171	0.0392	0.0035
1.90	0.0408	0.0026	-0.0842	-0.0154	0.0399	0.0028
2.00	0.0412	0.0022	-0.0847	-0.0141	0.0405	0.0024
Množ.	$q \cdot l_x^2$	$q \cdot l_y^2$	$q \cdot l_x^2$	$q \cdot l_y^2$	$q \cdot l_x^2$	$q \cdot l_y^2$

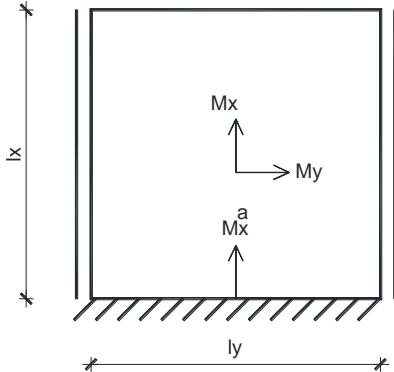
Ploča pozicije P101	
<p>Proračunski model (SHEMA 2)</p>  <p>$l_x = 3,35 \text{ m}$; $l_y = 8,6 \text{ m}$ $l_y / l_x = 8,6/3,35 = 2,57$</p>	<p>Analiza opterećenja $p = 1.35 \cdot g + 1.5 \cdot q$ $p = 1.35 \cdot 6.07 + 1.5 \cdot 1.5 = 10.44 \text{ kN/m}^2$</p> <p>Proračun momenata $k_x = 0.0594$; $k_y = 0.0037$ $k_x^a = -0.1213$ $M_x = k_x \cdot p \cdot l_x^2 = 0.0594 \cdot 10.44 \cdot 3,35^2 = 6,96 \text{ kNm/m}$ $M_y = k_y \cdot p \cdot l_y^2 = 0.0037 \cdot 10.44 \cdot 8,6^2 = 2,86 \text{ kNm/m}$ $M_x^a = k_x^a \cdot p \cdot l_x^2 = -0.1213 \cdot 10.44 \cdot 3,35^2 = -14,21 \text{ kNm/m}$</p> <p>Proračun armature $A_{sx} = M_x \cdot 100 / (0.9 \cdot d \cdot f_{yd})$ $A_{sx} = (6,96 \cdot 100) / (0.9 \cdot 12 \cdot 43.48) = 1,48 \text{ cm}^2/\text{m}$ $A_{sy} = M_y \cdot 100 / (0.9 \cdot d \cdot f_{yd})$ $A_{sy} = (2,86 \cdot 100) / (0.9 \cdot 12 \cdot 43.48) = 0,61 \text{ cm}^2/\text{m}$ $A_{sx}^a = M_x^a \cdot 100 / (0.9 \cdot d \cdot f_{yd})$ $A_{sx}^a = (14,21 \cdot 100) / (0.9 \cdot 12 \cdot 43.48) = 3,03 \text{ cm}^2/\text{m}$</p>

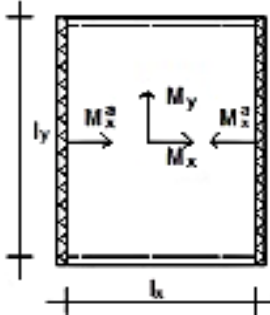
Ploča pozicije P102	
<p>Proračunski model (SHEMA 3)</p>  <p>$l_x = 3,20 \text{ m}$; $l_y = 8,6 \text{ m}$ $l_y / l_x = 8,6/3,2 = 2,68$</p>	<p>Analiza opterećenja $p = 1.35 \cdot g + 1.5 \cdot q$ $p = 1.35 \cdot 6.07 + 1.5 \cdot 1.5 = 10.44 \text{ kN/m}^2$</p> <p>Proračun momenata $k_x = 0.0417$; $k_y = 0.0019$ $k_x^a = -0.0833$ $M_x = k_x \cdot p \cdot l_x^2 = 0.0417 \cdot 10.44 \cdot 3,2^2 = 4,46 \text{ kNm/m}$ $M_y = k_y \cdot p \cdot l_y^2 = 0.0019 \cdot 10.44 \cdot 8,6^2 = 1,47 \text{ kNm/m}$ $M_x^a = k_x^a \cdot p \cdot l_x^2 = -0.0833 \cdot 10.44 \cdot 3,2^2 = -8,91 \text{ kNm/m}$</p> <p>Proračun armature $A_{sx} = M_x \cdot 100 / (0.9 \cdot d \cdot f_{yd})$ $A_{sx} = (4,46 \cdot 100) / (0.9 \cdot 12 \cdot 43.48) = 0,95 \text{ cm}^2/\text{m}$ $A_{sy} = M_y \cdot 100 / (0.9 \cdot d \cdot f_{yd})$ $A_{sy} = (1,47 \cdot 100) / (0.9 \cdot 12 \cdot 43.48) = 0,31 \text{ cm}^2/\text{m}$ $A_{sx}^a = M_x^a \cdot 100 / (0.9 \cdot d \cdot f_{yd})$ $A_{sx}^a = (8,91 \cdot 100) / (0.9 \cdot 12 \cdot 43.48) = 1,90 \text{ cm}^2/\text{m}$</p>

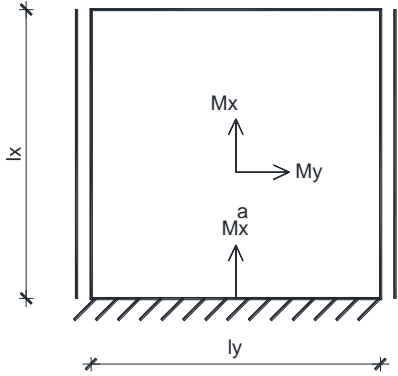
Ploča pozicije P103	
<p>Proračunski model (SHEMA 2)</p>  <p>$l_x = 3,25 \text{ m}$; $l_y = 10,3 \text{ m}$ $l_y / l_x = 10,3/3,25 = 3,17$</p>	<p>Analiza opterećenja $p = 1.35 \cdot g + 1.5 \cdot q$ $p = 1.35 \cdot 6.07 + 1.5 \cdot 1.5 = 10.44 \text{ kN/m}^2$</p> <p>Proračun momenata $k_x = 0.0594$; $k_y = 0.0037$ $k_x^a = -0.1213$ $M_x = k_x \cdot p \cdot l_x^2 = 0.0594 \cdot 10.44 \cdot 3.25^2 = 6,55 \text{ kNm/m}$ $M_y = k_y \cdot p \cdot l_y^2 = 0.0037 \cdot 10.44 \cdot 10.3^2 = 4,10 \text{ kNm/m}$ $M_x^a = k_x^a \cdot p \cdot l_x^2 = -0.1213 \cdot 10.44 \cdot 3.25^2 = -13,38 \text{ kNm/m}$</p> <p>Proračun armature $A_{sx} = M_x \cdot 100 / (0.9 \cdot d \cdot f_{yd})$ $A_{sx} = (6,55 \cdot 100) / (0.9 \cdot 12 \cdot 43.48) = 1,39 \text{ cm}^2/\text{m}$ $A_{sy} = M_y \cdot 100 / (0.9 \cdot d \cdot f_{yd})$ $A_{sy} = (4,1 \cdot 100) / (0.9 \cdot 12 \cdot 43.48) = 0,87 \text{ cm}^2/\text{m}$ $A_{sx}^a = M_x^a \cdot 100 / (0.9 \cdot d \cdot f_{yd})$ $A_{sx}^a = (13,38 \cdot 100) / (0.9 \cdot 12 \cdot 43.48) = 2,85 \text{ cm}^2/\text{m}$</p>

2.1.1 Proračun armature u gredama

Proračun potrebne armature u gredi u osi 2

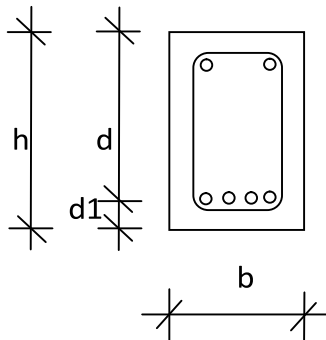

$h_f = 15 \text{ cm}$ – debljina ploče

$$h = \frac{0,85 \cdot L}{10} = \frac{0,85 \cdot 455}{10} = 38,7 \text{ cm} \rightarrow \text{odabrano } h = 40 \text{ cm}$$

$$b_w = 30 \text{ cm}$$

$$d = 40 - 5 = 35 \text{ cm}$$

$$\gamma_c = 25 \text{ kN/m}^3$$

$$g_{gr} = b_w \cdot h \cdot \gamma_c = 0,3 \cdot 0,4 \cdot 25 = 3 \text{ kN/m}$$

Proračunski model

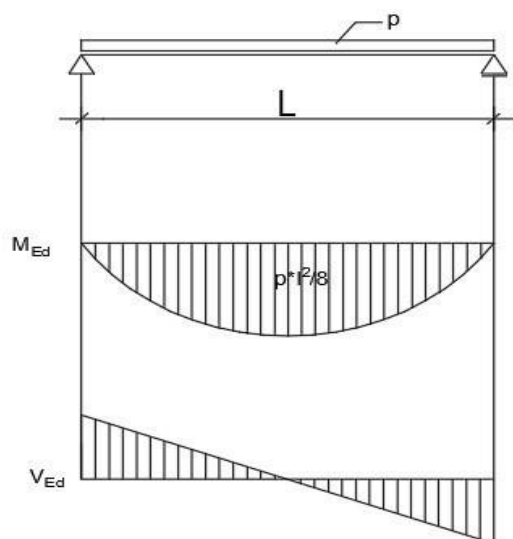

$$L = 4,55 \text{ m}$$

Analiza opterećenja

$$g_{\text{ploče}}=6.07 \text{ kN/m}^2$$

$$q_{\text{ploče}}=1.5 \text{ kN/m}^2$$

Utjecajna širina grede:

$$B=3,28 \text{ m}$$

-opterećenje od ploče

-stalno opterećenje:

$$g_{\text{ekv}}=g*B=6.07*3,28= 19,91 \text{ kN/m}$$

promjenjivo opterećenje:

$$q_{\text{ekv}}=q*B=1.5*3,28=4,92 \text{ kN/m}$$

opterećenje vlastite težine na gredu

$$g_{\text{gr}}=b*h*\gamma_c=0.3*0.4*25 = 3 \text{ kN/m}$$

Ukupno opterećenje

$$g_{\text{uk}}=g_{\text{ekv}}+g_{\text{gr}}=19,91+3= 22,91 \text{ kN/m}$$

$$q_{\text{uk}}=q_{\text{ekv}}=4,92 \text{ kN/m}$$

$$p= 1.35*g+1.5*q$$

$$p= 1.35*22,91+1.5*4,92=38,31$$

$$\text{kN/m}^2$$

Proračun momenata

$$M_{\text{Ed}}=p*L^2/ 8=38,31*4,55^2/ 8 = 99,14 \text{ kNm/m}$$

Proračun vertikalne sile

$$V_{Ed} = p \cdot L / 2 = 38,31 \cdot 4,55 / 2 = 87,16 \text{ kN}$$

Dimenzioniranje:

BETON: 30/37 $f_{ck} = 30 \text{ MPa}$

$$f_{cd} = f_{ck} / \gamma_c = 30 / 1.5 = 20 \text{ MPa}$$

ARMATURA: B500B $f_{yk} = 500 \text{ MPa}$

$$f_{yd} = f_{yk} / \gamma_s = 500 / 1.15 = 434.78 \text{ MPa}$$

Dimenzioniranje na moment

savijanja:

$$\mu_{sd} = \frac{M_{Ed,A}}{b_{eff} \cdot d^2 \cdot f_{cd}} = \frac{99,14 \cdot 100}{30 \cdot 35^2 \cdot 2} = 0,134$$

-iz tablice za $\epsilon_{s1} = 10\text{‰}$ uzimamo: $\epsilon_{c2} = 2,9\text{‰}$, $\xi = 0.225$, $\zeta = 0.910$, $\mu_{sd} = 0.134$

-armatura:

$$A_{s1} = \frac{M_{Ed,1}}{\zeta \cdot d \cdot f_{yd}} = \frac{9914}{0,910 \cdot 35 \cdot 43,48} = 7,15 \text{ cm}^2$$

ODABRANO: $A_{s1} = 7,70 \text{ cm}^2$, 5 ϕ 14

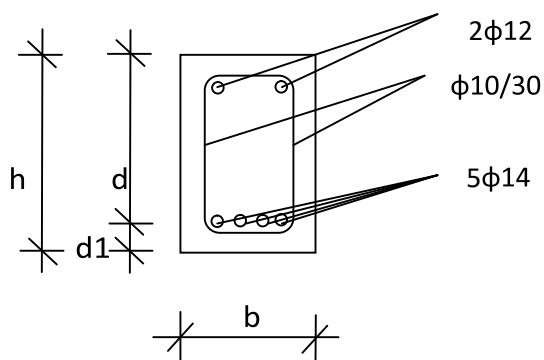

Uzdužna armatura na poprečnu silu ($V_{Rd,c}$):

$$V_{Ed} = 87,16 \text{ kN}$$

$$V_{Rd,c} = [C_{Rdc} \cdot k \cdot (100 \cdot \rho_l \cdot f_{ck})^{1/3} + k_1 \cdot \sigma_{cp}] \cdot b_w \cdot d$$

$$C_{Rdc} = \frac{0,18}{\gamma_c} = \frac{0,18}{1,5} = 0,12$$

$$k = 1,0 + \sqrt{\frac{200}{d}} = 1,0 + \sqrt{\frac{200}{350}} = 1,756 \leq 2,0 \rightarrow k = 1,756$$

$$k_1 = 0,15$$

$$\sigma_{cp} = \frac{N_{Ed}}{A_c} = 0 \quad (N_{Ed} = 0)$$

$$V_{Rdc} = [0,12 \cdot 1,756 \cdot (100 \cdot 0,00861 \cdot 30)^{1/3} + 0,15 \cdot 0] \cdot 300 \cdot 350 = 65403,8 \text{ N}$$

$$V_{Rdc} = 65,4 \text{ kN} < V_{Ed} = 87,16 \text{ kN}$$

$V_{Rd,c}$ mora biti veća od:

$$V_{Rd,c} \geq [v_{min} + k_1 \cdot \sigma_{cp}] \cdot b_w \cdot d$$

$$v_{min} = 0,035 \cdot k^{3/2} \cdot f_{ck}^{1/2} = 0,035 \cdot 1,756^{3/2} \cdot 30^{1/2} = 0,45$$

$$V_{Rd,c} \geq 0,45 \cdot 300 \cdot 350 = 47250 \text{ N} = 47,25 \text{ kN}$$

$$65,4 \text{ kN} > 47,25 \text{ kN} \text{ (uvjet je zadovoljen)}$$

Maksimalna poprečna sila

$$V_{Rd,max} = 0,5 \cdot v \cdot b_w \cdot d \cdot f_{cd}$$

$$v = 0,6 \cdot \left(1,0 - \frac{f_{ck}}{250}\right) = 0,6 \cdot \left(1,0 - \frac{30}{250}\right) = 0,528$$

$$V_{Rd,max} = 0,5 \cdot 0,528 \cdot 300 \cdot 350 \cdot 20 = 554400 \text{ N}$$

$$V_{Rd,max} = 554,4 \text{ kN} > V_{Ed} = 87,16 \text{ kN}$$

Maksimalni razmak spona (s_{max}):

$$\frac{V_{Ed}}{V_{Rd,max}} = \frac{87,16}{554,4} \approx 0,157 \rightarrow V_{Ed} = 0,157 \cdot V_{Rd,max} < 0,3 \cdot V_{Rd,max}$$

$$s_{w,max} = \min(0,75 \cdot d; 30 \text{ cm}) = \min(26,25 \text{ cm}; 30 \text{ cm}) \rightarrow s_{w,max} = 30 \text{ cm}$$

Minimalna površina jedne grane spone ($A_{sw,min}$):

$$A_{s_{w,min}} = \frac{\rho_{w,min} \cdot s_{w,max} \cdot b_w}{m} = \frac{0,00110 \cdot 30 \cdot 30}{2} = 0,495 \text{ cm}^2$$

odabrane spone: $\Phi 12/30 \text{ cm}$ ($A_{s_w} = 1,13 \text{ cm}^2$)

Otpornost elementa sa minimalnom poprečnom armaturom:

$$V_{Rd} = V_{Rd,s} = \frac{A_{s_w}}{s} \cdot z \cdot f_{ywd} \cdot m \cdot ctg\theta$$

$z \approx 0,9 \cdot d$ (krak unutrašnjih sila)

$\theta = 45^\circ$ (kut nagiba tlačnih dijagonala)

$$V_{Rd,s} = \frac{1,13}{30} \cdot (0,9 \cdot 35) \cdot 43,48 \cdot 2 \cdot 1 = 103,18 \text{ kN} > V_{Ed,0} = 87,16 \text{ kN}$$

(dovoljna je nosivost minimalne poprečne armature)

Potreban razmak spona (s_{pot}):

$$s_{pot} \leq m \cdot A_{s_w} \cdot f_{ywd} \cdot z / V_{sd} = 2 \cdot 1,13 \cdot 43,48 \cdot (35 \cdot 0,9) / 87,16 = 35,51 \text{ m}$$

odabrane spone: $\Phi 12/30 \text{ cm}$

-Površina minimalne armature za grede

Minimalna površina uzdužne armature:

$$A_{s1,min} \geq 0,26 \cdot f_{ctm} / f_{yk} \cdot b_t \cdot d \geq 0,0013 \cdot b_t \cdot d$$

b_t – srednja širina vlačnog područja

d – statička visina

f_{ctm} – srednja vlačna čvrstoća betona

f_{yk} – karakteristična granica popuštanja čelika

$$A_{s1,min} \geq 0,26 \cdot \frac{f_{ctm}}{f_{yk}} \cdot b_t \cdot d \geq 0,0013 \cdot b_t \cdot d$$

$$A_{s1,min} \geq 0,26 \cdot \frac{f_{ctm}}{f_{yk}} \cdot b_t \cdot d \geq 0,26 \cdot \frac{2,9}{500} \cdot 30 \cdot 35 = 1,58 \text{ cm}^2$$

$$A_{s1,min} \geq 0,0013 \cdot b_t \cdot d \geq 0,0013 \cdot 30 \cdot 35 = 1,365 \text{ cm}^2$$

LEŽAJ:

$$A_{s1,min} \geq 0,0013 \cdot b_t \cdot d \geq 0,0013 \cdot 30 \cdot 35 = 1,365 \text{ cm}^2$$

odabrano: $2\Phi 12$ ($A_{sw} = 2,26 \text{ cm}^2$)

Proračun potrebne armature u gredi u osi 3

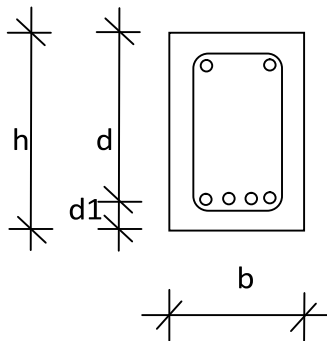

$h_f = 15 \text{ cm}$ – debljina ploče

$$h = \frac{0,85 \cdot L}{10} = \frac{0,85 \cdot 455}{10} = 38,7 \text{ cm} \rightarrow \text{odabrano } h = 40 \text{ cm}$$

$$b_w = 30 \text{ cm}$$

$$d = 40 - 5 = 35 \text{ cm}$$

$$\gamma_c = 25 \text{ kN/m}^3$$

$$g_{gr} = b_w \cdot h \cdot \gamma_c = 0,3 \cdot 0,4 \cdot 25 = 3 \text{ kN/m}$$

Proračunski model

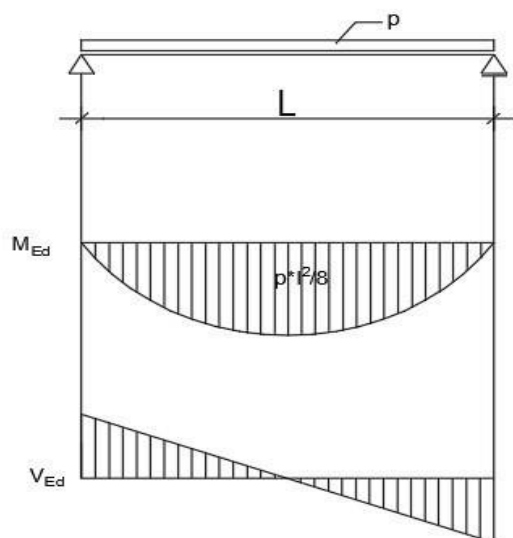

Analiza opterećenja

$$\underline{g_{ploče}=6.07 \text{ kN/m}^2}$$

$$\underline{q_{ploče}=1.5 \text{ kN/m}^2}$$

Utjecajna širina grede:

$$\underline{B=3,23 \text{ m}}$$

-opterećenje od ploče

-stalno opterećenje:

$$g_{ekv}=g*B=6.07*3,23= 19,61 \text{ kN/m}$$

promjenjivo opterećenje:

$$q_{ekv}=q*B=1.5*3,23=4,85 \text{ kN/m}$$

opterećenje vlastite težine na gredu

$$g_{gr}=b*h*\gamma_c=0.3*0.4*25 = 3 \text{ kN/m}$$

Ukupno opterećenje

$$g_{uk}=g_{ekv}+g_{gr}=19,61+3= 22,61 \text{ kN/m}$$

$$q_{uk}=q_{ekv}=4,85 \text{ kN/m}$$

$$p= 1.35*g+1.5*q$$

$$p= 1.35*22,61+1.5*4,85=37,79 \text{ kN/m}^2$$

Proračun momenata

$$M_{Ed}=p*L^2/ 8=37,79*7,35^2/ 8 = 255,25 \text{ kNm/m}$$

Proračun vertikalne sile

$$V_{Ed}=p*L/2=37,79*7,35/2=138,88 \text{ kN}$$

Dimenzioniranje:

$$\text{BETON: } 30/37 \text{ } f_{ck}=30\text{MPa}$$

$$f_{cd}=f_{ck}/\gamma_c=30/1.5=20\text{MPa}$$

ARMATURA: B500B $f_{yk}=500$ MPa

$f_{yd}=f_{yk}/\gamma_s=500/1.15=434.78$ MPa

Dimenzioniranje na moment

savijanja:

$$\mu_{sd} = \frac{M_{Ed,A}}{b_{eff} \cdot d^2 \cdot f_{cd}} = \frac{255,55 \times 100}{30 \cdot 35^2 \cdot 2} = 0,348$$

-iz tablice za $\epsilon_{s1}=10\text{‰}$ uzimamo: $\epsilon_{c2}=3,5\text{‰}$, $\xi=0.259$, $\zeta=0.892$, $\mu_{sd,lim}=0.159$

-armatura:

$$A_{s1} = \frac{M_{Ed,1}}{\zeta \cdot d \cdot f_{yd}} = \frac{25555}{0,892 \cdot 35 \cdot 43,48} = 18,83 \text{ cm}^2$$

$$M_{Rd,lim} = \mu_{sd,lim} \times b \times d^2 \times f_{cd} = 0.159 \times 30 \times 35^2 \times 2 = 116,87 \text{ kNm}$$

$$A_{s1} = \frac{M_{Rd,lim}}{\zeta_{lim} \times d \times f_{yd}} + \frac{M_{ed} - M_{Rd,lim}}{(d - d_2)f_{yd}} = \frac{11687}{0,892 \times 35 \times 43,48} + \frac{25555 - 11687}{(35 - 5) \times 43,48}$$

$$= 8,61 + 10,63 = 19,24 \text{ cm}^2$$

$$A_{s2} = \frac{M_{ed} - M_{Rd,lim}}{(d - d_2)f_{yd}} = 10,63 \text{ cm}^2$$

ODABRANO: $A_{s1}=19,63 \text{ cm}^2$, 4 ϕ 25

$A_{s2}=11,40 \text{ cm}^2$, 3 ϕ 22

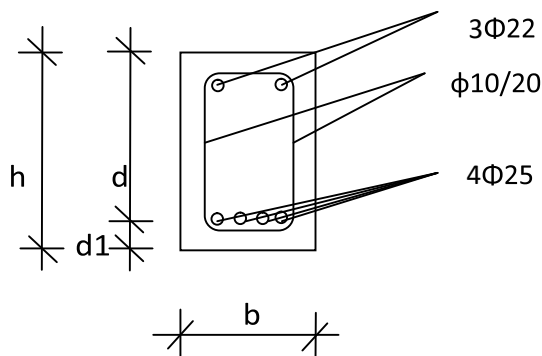

Uzdužna armatura na poprečnu silu ($V_{Rd,c}$):

$V_{Ed}=138,88$ kN

$$V_{Rd,c} = [C_{Rdc} \cdot k \cdot (100 \cdot \rho_l \cdot f_{ck})^{1/3} + k_1 \cdot \sigma_{cp}] \cdot b_w \cdot d$$

$$C_{Rdc} = \frac{0,18}{\gamma_c} = \frac{0,18}{1,5} = 0,12$$

$$k = 1,0 + \sqrt{\frac{200}{d}} = 1,0 + \sqrt{\frac{200}{350}} = 1,756 \leq 2,0 \rightarrow k = 1,756$$

$$k_1 = 0,15$$

$$\sigma_{cp} = \frac{N_{Ed}}{A_c} = 0 \quad (N_{Ed} = 0)$$

$$V_{Rdc} = [0,12 \cdot 1,756 \cdot (100 \cdot 0,00861 \cdot 30)^{1/3} + 0,15 \cdot 0] \cdot 300 \cdot 350 = 65403,8 \text{ N}$$

$$V_{Rdc} = 65,4 \text{ kN} < V_{Ed} = 138,88 \text{ kN}$$

$V_{Rd,c}$ mora biti veća od:

$$V_{Rd,c} \geq [v_{min} + k_1 \cdot \sigma_{cp}] \cdot b_w \cdot d$$

$$v_{min} = 0,035 \cdot k^{3/2} \cdot f_{ck}^{1/2} = 0,035 \cdot 1,756^{3/2} \cdot 30^{1/2} = 0,45$$

$$V_{Rd,c} \geq 0,45 \cdot 300 \cdot 350 = 47250 \text{ N} = 47,25 \text{ kN}$$

$$65,4 \text{ kN} > 47,25 \text{ kN} \text{ (uvjet je zadovoljen)}$$

Maksimalna poprečna sila

$$V_{Rd,max} = 0,5 \cdot v \cdot b_w \cdot d \cdot f_{cd}$$

$$v = 0,6 \cdot \left(1,0 - \frac{f_{ck}}{250}\right) = 0,6 \cdot \left(1,0 - \frac{30}{250}\right) = 0,528$$

$$V_{Rd,max} = 0,5 \cdot 0,528 \cdot 300 \cdot 350 \cdot 20 = 554400 \text{ N}$$

$$V_{Rd,max} = 554,4 \text{ kN} > V_{Ed} = 138,88 \text{ kN}$$

Maksimalni razmak spona (s_{max}):

$$\frac{V_{Ed}}{V_{Rd,max}} = \frac{138,88}{554,4} \approx 0,25 \rightarrow V_{Ed} = 0,25 \cdot V_{Rd,max} < 0,3 \cdot V_{Rd,max}$$

$$s_{w,max} = \min(0,75 \cdot d; 30 \text{ cm}) = \min(26,25 \text{ cm}; 30 \text{ cm}) \rightarrow s_{w,max} = 30 \text{ cm}$$

Minimalna površina jedne grane spona ($A_{sw,min}$):

$$A_{sw,min} = \frac{\rho_{w,min} \cdot s_{w,max} \cdot b_w}{m} = \frac{0,00110 \cdot 30 \cdot 30}{2} = 0,495 \text{ cm}^2$$

odabrane spone: $\Phi 12/30 \text{ cm}$ ($A_{sw} = 1,13 \text{ cm}^2$)

Otpornost elementa sa minimalnom poprečnom armaturom:

$$V_{Rd} = V_{Rd,s} = \frac{A_{sw}}{s} \cdot z \cdot f_{ywd} \cdot m \cdot ctg\theta$$

$z \approx 0,9 \cdot d$ (krak unutrašnjih sila)

$\theta = 45^\circ$ (kut nagiba tlačnih dijagonala)

$$V_{Rd,s} = \frac{1,13}{30} \cdot (0,9 \cdot 35) \cdot 43,48 \cdot 2 \cdot 1 = 103,18 \text{ kN} < V_{Ed,0} = 138,88 \text{ kN}$$

(nije dovoljna nosivost minimalne poprečne armature)

$$s_{w,pot} \leq \frac{m \cdot A_{sw} \cdot f_{yw,d} \cdot z}{V_{Ed}} = \frac{2 \cdot 1,13 \cdot 43,48 \cdot (0,9 \cdot 30)}{138,88} = 19,1 \text{ cm}$$

odabrane spone: $\Phi 12/19 \text{ cm}$

-Površina minimalne armature za grede

Minimalna površina uzdužne armature:

$$A_{s1,min} \geq 0,26 \cdot f_{ctm} / f_{yk} \cdot b_t \cdot d \geq 0,0013 \cdot b_t \cdot d$$

b_t – srednja širina vlačnog područja

d – statička visina

f_{ctm} – srednja vlačna čvrstoća betona

f_{yk} – karakteristična granica popuštanja čelika

$$A_{s1,min} \geq 0,26 \cdot \frac{f_{ctm}}{f_{yk}} \cdot b_t \cdot d \geq 0,0013 \cdot b_t \cdot d$$

$$A_{s1,min} \geq 0,26 \cdot \frac{f_{ctm}}{f_{yk}} \cdot b_t \cdot d \geq 0,26 \cdot \frac{2,9}{500} \cdot 30 \cdot 35 = 1,58 \text{ cm}^2$$

$$A_{s1,min} \geq 0,0013 \cdot b_t \cdot d \geq 0,0013 \cdot 30 \cdot 35 = 1,365 \text{ cm}^2$$

LEŽAJ:

$$A_{s1,min} \geq 0,0013 \cdot b_t \cdot d \geq 0,0013 \cdot 30 \cdot 35 = 1,365 \text{ cm}^2$$

odabrano: $2\Phi 12$ ($A_{sw} = 2,26 \text{ cm}^2$)

2.2 Ploča POZ 200 i POZ 300 (sitno rebrasti stropni sustav s gredicama)

Međukatna konstrukcija POZ 200 je sitno rebrasti stropni sustav s gredicama.

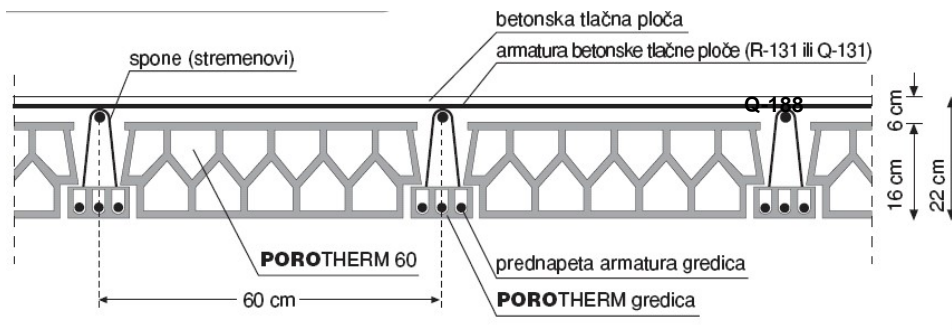

Poprečni presjek stropa

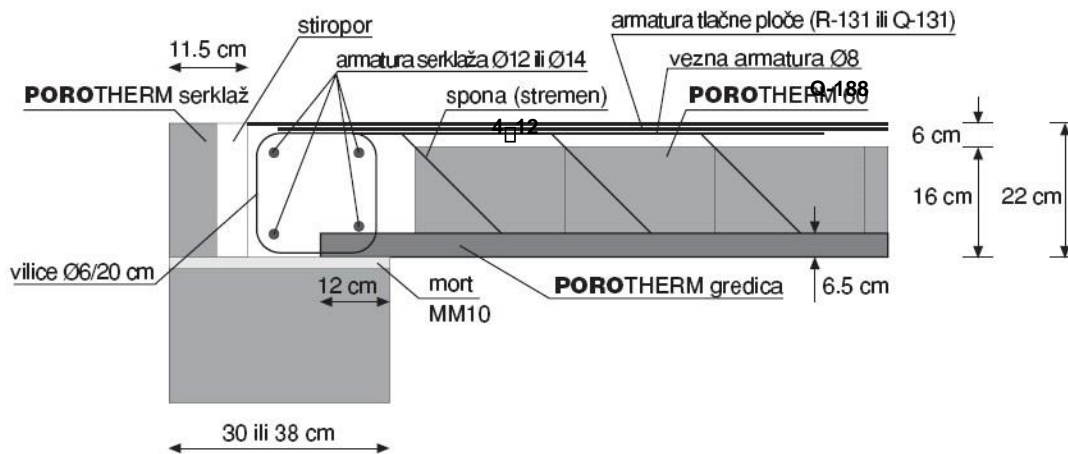

Uzdužni presjek stropa

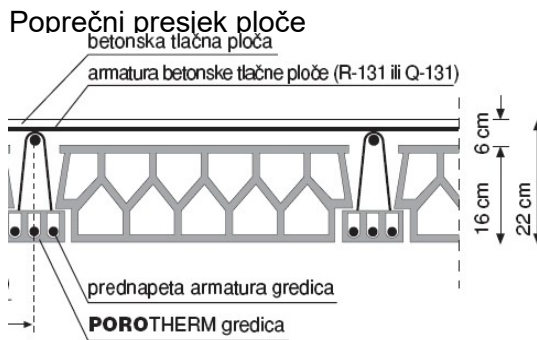

Statička visina: $d=19.0$ cm
 Krak sila: $z=16.0$ cm
 Razmak gredica: $b_w=60$ cm
 Beton: **C 30/37**
 $f_{ck}=30.0$ MPa
 $E_{cm}=32.8$ GPa
 $\gamma_c=1.5$
 Armatura: **B 500B**
 $f_y=500$ MPa
 $\gamma_s=1.15$

Limitirajući moment savijanja:

$$M_{Rd,lim}=0.159*(b_w*d^2)*f_{cd}$$

$$M_{Rd,lim}=0.159*(0.6*0.190^2)*(30/1.5)*1000=68.9 \text{ kNm}$$

Nosivost na poprečnu silu bez udjela betona:Dijagonale: $4\phi 4$

$$V_{RD} = \frac{D^2 \times \pi}{4} \times 4 \times f_{yd} \times \cos(45)$$

$$V_{Rd} = (0.4^2 * 3.14 / 4) * 4 * 43.48 * 0.707 = 15.44 \text{ kN}$$

Proračun armature u donjoj zoni gredice:

$$A_s = M_{Ed} * 100 / (z * f_{yd}) = M_{Ed} * 100 / (16.0 * (50 / 1.15)) = M_{Ed} * 0.144$$

Napomene:

-Prethodni izraz vrijedi za moment M_{Ed} i armatur A_s u $[\text{cm}^2]$.

Analiza opterećenja:**Stalno djelovanje:**

sitno rebrasta međukatna konstrukcija (gredice, ispuna i tlačna ploča); $d=22$ cm

3.00 kN/m²

Dodatno stalno djelovanje:

pregradni zidovi	0.50 kN/m ²
završni sloj poda	0.50 kN/m ²
<u>a-c estrih; d=6 cm; $\gamma=22$ kN/m³</u>	<u>1.32 kN/m²</u>

Dodatno stalno djelovanje **$g=2.30$ kN/m²**

Promjenjivo djelovanje:

sobe, dnevni boravak, kuhinja,... **1.50 kN/m²**

stubište **3.00 kN/m²**

balkonske ploče **4.00 kN/m²**

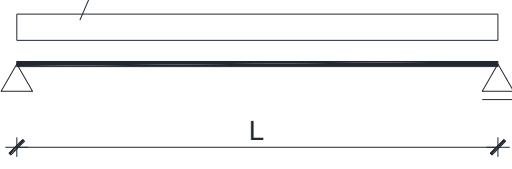
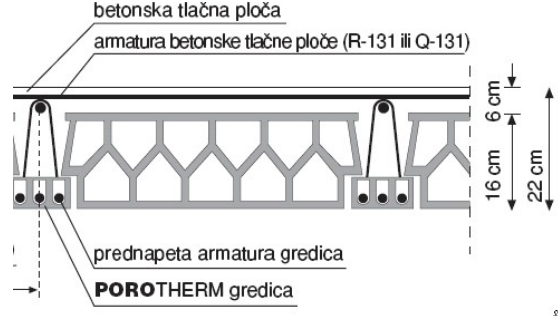
Ploča pozicije P201	
<p>Proračunski model</p>  <p>$L=3.35$ m; razmak gredica 60 cm</p> <p>Analiza opterećenja: $p=(1.35*(3.0+2.3)+1.5*1.5)*0.6 = 5.64$ kN/m</p> <p>Rezne sile: $M_{Ed}=p*L^2 / 8 = 5.64*3,35^2/8 = 7,91$ kNm</p> <p>Armatura: $A_s=M_{Ed}*100/(z*f_{yd})=7,91*100/(16*43.48)=$ $1,14$ cm²</p>	<p>Poprečni presjek</p>  <p>Krak sila $z \approx 16$ cm</p> <p>Beton: C 30/37 $f_{ck}=30.0$ MPa $E_{cm}=32.8$ GPa $\gamma_c=1.5$</p> <p>Armatura: B 500B $f_y=500$ MPa $\gamma_s=1.15$</p>

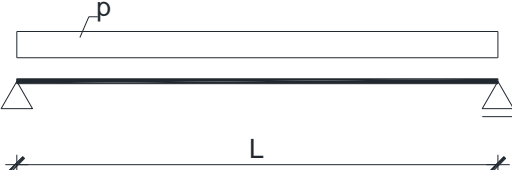
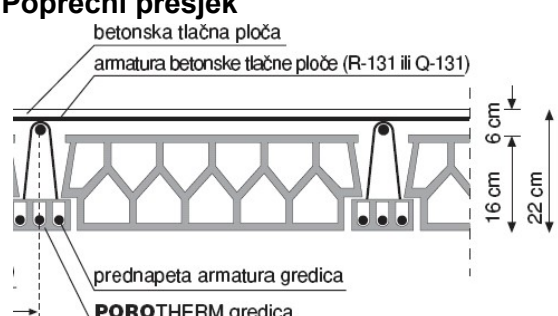
Ploča pozicije P203	
<p>Proračunski model</p>  <p>$L= 3,25$ m; razmak gredica 60 cm</p> <p>Analiza opterećenja: $p= (1.35*(3.0+2.3)+1.5*1.5)*0.6 = 5.64$ kN/m</p> <p>Rezne sile: $M_{Ed}=p*L^2 / 8 = 5,64*3,25^2/8 = 7,45$ kNm</p> <p>Armatura: $A_s=M_{Ed}*100/(z*f_{yd})= 7,45*100/(16*43,48)=$ $1,07$ cm²</p>	<p>Poprečni presjek</p>  <p>Krak sila $z \approx 16$ cm</p> <p>Beton: C 30/37 $f_{ck}=30.0$ MPa $E_{cm}=32.8$ GPa $\gamma_c=1.5$</p> <p>Armatura: B 500B $f_y=500$ MPa $\gamma_s=1.15$</p>

Ploča POZ 202 (a-b ploča)

Ploča pozicije P202	
<p>Proračunski model (SHEMA 3)</p> <p>$l_x = 3,20 \text{ m}$; $l_y = 8,6 \text{ m}$ $l_y / l_x = 8,6 / 3,2 = 2,68$</p>	<p>Analiza opterećenja $p = 1.35 \cdot g + 1.5 \cdot q$ $p = 1.35 \cdot 6.07 + 1.5 \cdot 1.5 = 10.44 \text{ kN/m}^2$</p> <p>Proračun momenata $k_x = 0.0417$; $k_y = 0.0019$ $k_x^a = -0.0833$ $M_x = k_x \cdot p \cdot l_x^2 = 0.0417 \cdot 10.44 \cdot 2,55^2 = 2,83 \text{ kNm/m}$ $M_y = k_y \cdot p \cdot l_y^2 = 0.0019 \cdot 10.44 \cdot 8,6^2 = 1,47 \text{ kNm/m}$ $M_x^a = k_x^a \cdot p \cdot l_x^2 = -0.0833 \cdot 10.44 \cdot 2,55^2 = -5,65 \text{ kNm/m}$</p> <p>Proračun armature $A_{sx} = M_x \cdot 100 / (0.9 \cdot d \cdot f_{yd})$ $A_{sx} = (2,83 \cdot 100) / (0.9 \cdot 12 \cdot 43.48) = 0,60 \text{ cm}^2/\text{m}$ $A_{sy} = M_y \cdot 100 / (0.9 \cdot d \cdot f_{yd})$ $A_{sy} = (1,47 \cdot 100) / (0.9 \cdot 12 \cdot 43.48) = 0,31 \text{ cm}^2/\text{m}$ $A_{sx}^a = M_x^a \cdot 100 / (0.9 \cdot d \cdot f_{yd})$ $A_{sx}^a = (5,65 \cdot 100) / (0.9 \cdot 12 \cdot 43.48) = 1,20 \text{ cm}^2/\text{m}$</p>

3. PRORAČUN ZIDOVA

3.1 Proračun zidova na vertikalna opterećenja

3.1.1 Podaci za proračun zidova:

blok opeka, dimenzije: $d \times \check{s} \times v = 25 \times 30 \times 23.8 \text{ cm}$

srednja tlačna čvrstoća bloka: $f_{ck,sred} = 10 \text{ MPa}$

normalizirana tlačna čvrstoća bloka: $f_b = 10 \text{ MPa}$

grupa zidnih blokova: 2 ($K = 0.45$)

mort: M5 ($f_m = 5.0 \text{ MPa}$)

tlačna čvrstoća zida: $f_k = K * f_b^{0.7} * f_m^{0.3} = 0.45 * 10^{0.7} * 5^{0.3} = 3.66 \text{ MPa}$

faktor smanjenja za vitkost i ekscentričnost: $\varphi_{i,m} = 0.70$

parcijalni koef. sigurnosti za materijale: $\gamma_M = 2.2$ (razred proizvodnje B, razred izvedbe 2.)

debljina nosivih zidova: $t = 30 \text{ cm}$

računska uzdužna sila: $N_{Sd} = N_g * 1.35 + N_q * 1.5$

računska nosivost na uzdužnu silu: $N_{Rd} = \varphi_{i,m} * A * f_k / \gamma_M$

U proračunu zidova na vertikalna djelovanja dokazuje se da je

$N_{Sd} < N_{Rd}$

Proračun se provodi tablično kako je prikazano na slijedećoj stranici gdje je:

L = računski duljina zida [m]

t = debljina zida [m]

g = stalno opterećenje po jednoj međukatnoj konstrukciji

q = promjenjivo opterećenje po jednoj međukatnoj konstrukciji

g_z = vlastita težina zida; $g_z = t * \gamma_z + g_{zbuke} = 0.3 * 10.0 + 0.03 * 20.0 = 3.00 + 0.60 = 3.60 \text{ kN/m}^2$

L' i b' = utjecajna duljina i širina međukatne ploče koja se oslanja na zid [m]

n = broj etaža (broj međukatnih ploča)

N_g = vertikalno stalno djelovanje: $N_g = (g * L' * b' + g_z * L * h) * n$

N_q = vertikalno promjenjivo djelovanje: $N_q = (q * L' * b') * n$

o = duljina otvora [m]

A_z = računski površina zida: $A_z = (L - o) * t \text{ [m}^2\text{]}$

Zid ZX1

<p>Geometrijske karakteristike zida: duljina zida: $L=1,70$ m debljina zida: $t=0.30$ m visina zida: $h=3*2.70m+0.50m=8.60$ m</p> <p>Utjecajne površine ploča: $A_{zx1,100}=3.15$ m² $A_{zx1,200}=4.47$ m² $A_{zx1,300}=4.47$ m²</p> <p>Analiza opterećenja:</p> <p>Stalno:</p> <p>$g_{100}=6.07$ kN/m² $g_{200}=5.30$ kN/m²</p> <p>$g_{300}=5,30$ kN/m²</p> <p>Pokretno:</p> <p>$q_{100}=1.50$kN/m² $q_{200}=1.50$kN/m² $q_{300}=1.50$ kN/m²</p> <p>Vlastita težina zida ($t=0,30$m): $g_z=3.60$ kN/m²</p>	<p>Proračun zida na vertikalna opterećenja:</p> <p>Uzdužna sila od stalnog djelovanja: $N_g=A_{zx1,100}*g_{100}+ A_{zx1,200}*g_{200}+ A_{zx1,300}*g_{300}+L*h*g_z$ $N_g=3.15*6.07+4.47*5.30+4.47*5,30+1.7*8.6*3.60$ $N_g=119.13$ kN</p> <p>Uzdužna sila od pokretnog djelovanja: $N_q=A_{zx1,100}*q_{100}+ A_{zx1,200}*q_{200}+ A_{zx1,300}*q_{300}$ $N_q=3.15*1.50+4.47*1.50+4.47*1.50$ $N_q=18.14$ kN</p> <p>Računska uzdužna sila: $N_{sd}=1.35*N_g+1.5*N_q$ $N_{sd}=1.35*119.13+1.5*18.14= 188$ kN</p> <p>Računska otpornost: $N_{Rd}=\phi_{i,m} * A * f_k / \gamma_M$ $N_{Rd}=0.7*(170*30)*0.366/2.2= 593.9$ kN > 188 kN</p>
---	---

Zid ZX2

<p>Geometrijske karakteristike zida: duljina zida: $L=2.40$ m debljina zida: $t=0.30$ m visina zida: $h=3*2,70m+0.50m=8,60$ m</p> <p>Utjecajne površine ploča: $A_{zx2,100}=7.8$ m² $A_{zx2,200}=7.8$ m² $A_{zx2,300}=7.8$ m²</p> <p>Analiza opterećenja: Stalno: $g_{100}=6.07$ kN/m² $g_{200}=5.30$ kN/m² $g_{300}=5,30$ kN/m² Pokretno $q_{100}=1.50$kN/m² $q_{200}=1.50$kN/m² $q_{300}=1.50$ kN/m² Vlastita težina zida ($t=0,30$m): $g_z=3.60$ kN/m²</p>	<p>Proračun zida na vertikalna opterećenja:</p> <p>Uzdužna sila od stalnog djelovanja: $N_g=A_{zx2,100}*g_{100}+ A_{zx2,200}*g_{200}+ A_{zx2,300}*g_{300}+L*h*g_z$ $N_g=7.8 *6.07+7.8 *5.30+7.8 *5,30+2.4*8,6*3,6$ $N_g=204.33$ kN</p> <p>Uzdužna sila od pokretnog djelovanja: $N_q=A_{zx2,100}*q_{100}+ A_{zx2,200}*q_{200}+ A_{zx2,300}*q_{300}$ $N_q=7.8 *1.50+7.8 *1.50+7.8 *1.50$ $N_q=35.1$ kN</p> <p>Računska uzdužna sila: $N_{sd}=1.35*N_g+1.5*N_q$ $N_{sd}=1.35*204.33+1.5*35.1 = 328.5$ kN</p> <p>Računska otpornost: $N_{Rd}=\phi_{i,m} * A * f_k / \gamma_M$ $N_{Rd}=0.7*(240*30)*0.366/2.2= 838.5$ kN > 328.5 kN</p>
--	---

Zid ZX3

<p>Geometrijske karakteristike zida: duljina zida: $L=1,70$ m debljina zida: $t=0.30$ m visina zida: $h=3*2.70m+0.50m=8.60$ m</p> <p>Utjecajne površine ploča: $A_{zx3,100}=3.15$ m² $A_{zx3,200}=4.47$ m² $A_{zx3,300}=4.47$ m²</p> <p>Analiza opterećenja: Stalno: $g_{100}=6.07$ kN/m² $g_{200}=5.30$ kN/m² $g_{300}=5,30$ kN/m² Pokretno: $q_{100}=1.50$kN/m² $q_{200}=1.50$kN/m² $q_{300}=1.50$ kN/m² Vlastita težina zida ($t=0,30$m): $g_z=3.60$ kN/m²</p>	<p>Proračun zida na vertikalna opterećenja:</p> <p>Uzdužna sila od stalnog djelovanja: $N_g=A_{zx3,100}*g_{100}+ A_{zx3,200}*g_{200}+ A_{zx3,300}*g_{300}+L*h*g_z$ $N_g=3.15*6.07+4.47*5.30+4.47*5,30+1.7*8.6*3.60$ $N_g=119.13$ kN</p> <p>Uzdužna sila od pokretnog djelovanja: $N_q=A_{zx3,100}*q_{100}+ A_{zx3,200}*q_{200}+ A_{zx3,300}*q_{300}$ $N_q=3.15*1.50+4.47*1.50+4.47*1.50$ $N_q=18.14$ kN</p> <p>Računska uzdužna sila: $N_{sd}=1.35*N_g+1.5*N_q$ $N_{sd}=1.35*119.13+1.5*18.14= 188$ kN</p> <p>Računska otpornost: $N_{Rd}=\phi_{i,m} * A * f_k / \gamma_M$ $N_{Rd}=0.7*(170*30)*0.366/2.2= 593.9$ kN > 188 kN</p>
--	---

Zid ZX4

<p>Geometrijske karakteristike zida: duljina zida: $L=2.2$ m debljina zida: $t=0.30$ m visina zida: $h=3*2,70m+0.50m=8,60$ m</p> <p>Utjecajne površine ploča: $A_{zx4,100}=14.70$ m² $A_{zx4,200}=16.02$ m² $A_{zx4,300}=16.02$ m²</p> <p>Analiza opterećenja: Stalno: $g_{100}=6.07$ kN/m² $g_{200}=5.30$ kN/m² $g_{300}=5,30$ kN/m² Pokretno: $q_{100}=1.50$ kN/m² $q_{200}=1.50$ kN/m² $q_{300}=1.50$ kN/m² Vlastita težina zida ($t=0,30m$): $g_z=3.60$ kN/m²</p>	<p>Proračun zida na vertikalna opterećenja:</p> <p>Uzdužna sila od stalnog djelovanja: $N_g=A_{zx4,100}*g_{100}+ A_{zx4,200}*g_{200}+ A_{zx4,300}*g_{300}+L*h*g_z$ $N_g=14.7 *6.07+16.02*5.30+16.02*5,30+2.2*8,6*3,6$ $N_g=327.15$ kN</p> <p>Uzdužna sila od pokretnog djelovanja: $N_q=A_{zx4,100}*q_{100}+ A_{zx4,200}*q_{200}+ A_{zx4,300}*q_{300}$ $N_q=14.7 *1.50+16.02*1.50+16.02*1.50$ $N_q=70.11$ kN</p> <p>Računska uzdužna sila: $N_{sd}=1.35*N_g+1.5*N_q$ $N_{sd}=1.35*327.15+1.5*70.11 = 546.82$ kN</p> <p>Računska otpornost: $N_{Rd}=\phi_{i,m} * A * f_k / \gamma_M$ $N_{Rd}=0.7*(220*30)*0.366/2.2= 768.6$ kN > 547 kN</p>
--	--

Zid ZX5

<p>Geometrijske karakteristike zida: duljina zida: $L=1.05$ m debljina zida: $t=0.30$ m visina zida: $h=3*2.70m+0.50m=8.60$ m</p> <p>Utjecajne površine ploča: $A_{zx5,100}=13.89$ m² $A_{zx5,200}=12.28$ m² $A_{zx5,300}=12.28$ m²</p> <p>Analiza opterećenja: Stalno: $g_{100}=6.07$ kN/m² $g_{200}=5.30$ kN/m² $g_{300}=5.30$ kN/m² Pokretno: $q_{100}=1.50$ kN/m² $q_{200}=1.50$ kN/m² $q_{300}=1.50$ kN/m² Vlastita težina zida ($t=0,30m$): $g_z=3.60$ kN/m²</p>	<p>Proračun zida na vertikalna opterećenja:</p> <p>Uzdužna sila od stalnog djelovanja: $N_g=A_{zx5,100}*g_{100}+ A_{zx5,200}*g_{200}+ A_{zx5,300}*g_{300}+L*h*g_z$ $N_g=13.89*6.07+12.28*5.30+12.28*5,30+1.05*8.6*3.60$ $N_g=246.99$ kN</p> <p>Uzdužna sila od pokretnog djelovanja: $N_q=A_{zx5,100}*q_{100}+ A_{zx5,200}*q_{200}+ A_{zx5,300}*q_{300}$ $N_q=13.89*1.50+12.28*1.50+12.28*1.50$ $N_q=57.68$ kN</p> <p>Računska uzdužna sila: $N_{sd}=1.35*N_g+1.5*N_q$ $N_{sd}=1.35*246.99+1.5*57.68= 419.96$ kN</p> <p>Računska otpornost: $N_{Rd}=\phi_{i,m} * A * f_k / \gamma_M$ $N_{Rd}=0.7*(105*30)*2.5/1.5= 3675$ kN > 420 kN</p>
---	--

Zid ZX6

<p>Geometrijske karakteristike zida: duljina zida: $L=4.05$ m debljina zida: $t=0.30$ m visina zida: $h=3*2,70m+0.50m=8,60$ m</p> <p>Utjecajne površine ploča: $A_{zx6,100}=17.54$ m² $A_{zx6,200}=18.94$ m² $A_{zx6,300}=18.94$ m²</p> <p>Analiza opterećenja: Stalno: $g_{100}=6.07$ kN/m² $g_{200}=5.30$ kN/m² $g_{300}=5,30$ kN/m² Pokretno: $q_{100}=1.50$ kN/m² $q_{200}=1.50$ kN/m² $q_{300}=1.50$ kN/m² Vlastita težina zida ($t=0,30$m): $g_z=3.60$ kN/m²</p>	<p>Proračun zida na vertikalna opterećenja:</p> <p>Uzdužna sila od stalnog djelovanja: $N_g=A_{zx6,100}*g_{100}+ A_{zx6,200}*g_{200}+ A_{zx6,300}*g_{300}+L*h*g_z$ $N_g=17.54*6.07+18.94*5.30+18.94*5,30+4.05*8,6*3,6$ $N_g=432.62$ kN</p> <p>Uzdužna sila od pokretnog djelovanja: $N_q=A_{zx6,100}*q_{100}+ A_{zx6,200}*q_{200}+ A_{zx6,300}*q_{300}$ $N_q=17.54 *1.50+18.94*1.50+18.94*1.50$ $N_q=83.13$ kN</p> <p>Računska uzdužna sila: $N_{sd}=1.35*N_g+1.5*N_q$ $N_{sd}=1.35*432.62+1.5*83.13 = 708.73$ kN</p> <p>Računska otpornost: $N_{Rd}=\phi_{i,m} * A * f_k / \gamma_M$ $N_{Rd}=0.7*(405*30)*0.366/2.2= 1415$ kN > 709 kN</p>
---	---

Zid ZX7

<p>Geometrijske karakteristike zida: duljina zida: $L=8.90$ m debljina zida: $t=0.30$ m visina zida: $h=3*2.70m+0.50m=8.6$ m</p> <p>Utjecajne površine ploča: $A_{zx7,100}=11.60$ m² $A_{zx7,200}=14.41$ m² $A_{zx7,300}=14.41$ m²</p> <p>Analiza opterećenja: Stalno: $g_{100}=6.07$ kN/m² $g_{200}=5.30$ kN/m² $g_{300}=5,30$ kN/m² Pokretno: $q_{100}=1.50$ kN/m² $q_{200}=1.50$ kN/m² $q_{300}=1.50$ kN/m² Vlastita težina zida ($t=0,30$m): $g_z=3.60$ kN/m²</p>	<p>Proračun zida na vertikalna opterećenja:</p> <p>Uzdužna sila od stalnog djelovanja: $N_g=A_{zx7,100}*g_{100}+ A_{zx7,200}*g_{200}+ A_{zx7,300}*g_{300}+L*h*g_z$ $N_g=11.6*6.07+14.41*5.30+14.41*5,30+8.9*8.6*3.60$ $N_g= 498.7$ kN</p> <p>Uzdužna sila od pokretnog djelovanja: $N_q=A_{zx7,100}*q_{100}+ A_{zx7,200}*q_{200}+ A_{zx7,300}*q_{300}$ $N_q=11.6*1.50+14.41*1.50+14.41*1.50$ $N_q=60.63$ kN</p> <p>Računska uzdužna sila: $N_{sd}=1.35*N_g+1.5*N_q$ $N_{sd}=1.35*498.7+1.5*60.63= 764.19$ kN</p> <p>Računska otpornost: $N_{Rd}=\phi_{i,m} * A * f_k / \gamma_M$ $N_{Rd}=0.7*(890*30)*0.366/2.2= 3109$ kN > 764.2 kN</p>
---	--

Zid ZY1

<p>Geometrijske karakteristike zida: duljina zida: $L=3.55$ m debljina zida: $t=0.30$ m visina zida: $h=3*2,70m+0.50m=8,60$ m</p> <p>Utjecajne površine ploča: $A_{zy1,100}=2,64$ m² $A_{zy1,200}=0$ m² $A_{zy1,300}=0$ m²</p> <p>Analiza opterećenja: Stalno: $g_{100}=6.07$ kN/m² $g_{200}=5.30$ kN/m² $g_{300}=5,30$ kN/m² Pokretno: $q_{100}=1.50$ kN/m² $q_{200}=1.50$ kN/m² $q_{300}=1.50$ kN/m² Vlastita težina zida ($t=0,30m$): $g_z=3.60$ kN/m²</p>	<p>Proračun zida na vertikalna opterećenja:</p> <p>Uzdužna sila od stalnog djelovanja: $N_g=A_{zy1,100}*g_{100}+ A_{zy1,200}*g_{200}+ A_{zy1,300}*g_{300}+L*h*g_z$ $N_g=2,64*6.07+0*5.30+0*5,30+3.55*8,6*3,6$ $N_g=125.93$ kN</p> <p>Uzdužna sila od pokretnog djelovanja: $N_q=A_{zy1,100}*q_{100}+ A_{zy1,200}*q_{200}+ A_{zy1,300}*q_{300}$ $N_q=2,64*1.50+0*1.50+0*1.50$ $N_q=4$ kN</p> <p>Računska uzdužna sila: $N_{sd}=1.35*N_g+1.5*N_q$ $N_{sd}=1.35*125.93+1.5*4= 176$ kN</p> <p>Računska otpornost: $N_{Rd}=\phi_{i,m} * A * f_k / \gamma_M$ $N_{Rd}=0.7*(355*30)*0.366/2.2= 1240$ kN > 176 kN</p>
---	--

Zid ZY2

<p>Geometrijske karakteristike zida: duljina zida: $L=3.55$ m debljina zida: $t=0.30$ m visina zida: $h=3*2,7m+0.50m=8,60$ m</p> <p>Utjecajne površine ploča: $A_{zy2,100}=2,64$ m² $A_{zy2,200}=0$ m² $A_{zy2,300}=0$ m²</p> <p>Analiza opterećenja: Stalno: $g_{100}=6.07$ kN/m² $g_{200}=5.30$ kN/m² $g_{300}=5,30$ kN/m² Pokretno: $q_{100}=1.50$ kN/m² $q_{200}=1.50$ kN/m² $q_{300}=1.50$ kN/m² Vlastita težina zida ($t=0,30m$): $g_z=3.60$ kN/m²</p>	<p>Proračun zida na vertikalna opterećenja:</p> <p>Uzdužna sila od stalnog djelovanja: $N_g=A_{zy2,100}*g_{100}+ A_{zy2,200}*g_{200}+ A_{zy2,300}*g_{300}+L*h*g_z$ $N_g=2,64*6.07+0*5.30+0*5,30+3.55*8,6*3,6$ $N_g=125.93$ kN</p> <p>Uzdužna sila od pokretnog djelovanja: $N_q=A_{zy2,100}*q_{100}+ A_{zy2,200}*q_{200}+ A_{zy2,300}*q_{300}$ $N_q=2,64*1.50+0*1.50+0*1.50$ $N_q=4$ kN</p> <p>Računska uzdužna sila: $N_{sd}=1.35*N_g+1.5*N_q$ $N_{sd}=1.35*125.93+1.5*4= 176$ kN</p> <p>Računska otpornost: $N_{Rd}=\phi_{i,m} * A * f_k / \gamma_M$ $N_{Rd}=0.7*(355*30)*0.366/2.2= 1240$ kN > 176 kN</p>
---	--

Zid ZY3

<p>Geometrijske karakteristike zida: duljina zida: $L=5.35$ m debljina zida: $t=0.30$ m visina zida: $h=3*2,70m+0.50m=8,60$ m</p> <p>Utjecajne površine ploča: $A_{zy3,100}=5.01$ m² $A_{zy3,200}=2,20$ m² $A_{zy3,300}=2,20$ m²</p> <p>Analiza opterećenja: Stalno: $g_{100}=6.07$ kN/m² $g_{200}=5.30$ kN/m² $g_{300}=5,30$ kN/m² Pokretno: $q_{100}=1.50$ kN/m² $q_{200}=1.50$ kN/m² $q_{300}=1.50$ kN/m² Vlastita težina zida ($t=0,30m$): $g_z=3.60$ kN/m²</p>	<p>Proračun zida na vertikalna opterećenja:</p> <p>Uzdužna sila od stalnog djelovanja: $N_g=A_{zy3,100}*g_{100}+ A_{zy3,200}*g_{200}+ A_{zy3,300}*g_{300}+L*h*g_z$ $N_g=5.01*6.07+2,20*5.30+2,20*5,30+5.35*8,6*3,6$ $N_g=219.37$ kN</p> <p>Uzdužna sila od pokretnog djelovanja: $N_q=A_{zy3,100}*q_{100}+ A_{zy3,200}*q_{200}+ A_{zy3,300}*q_{300}$ $N_q=5.01*1.50+2,20*1.50+2,20*1.50$ $N_q=14.12$ kN</p> <p>Računska uzdužna sila: $N_{sd}=1.35*N_g+1.5*N_q$ $N_{sd}=1.35*219.37+1.5*14.12= 317.33$ kN</p> <p>Računska otpornost: $N_{Rd}=\phi_{i,m} * A * f_k / \gamma_M$ $N_{Rd}=0.7*(535*30)*0.366/2.2= 1869$ kN > 317.3 kN</p>
---	---

Zid ZY4

<p>Geometrijske karakteristike zida: duljina zida: $L=6.85$ m debljina zida: $t=0.30$ m visina zida: $h=3*2,7m+0.50m=8,60$ m</p> <p>Utjecajne površine ploča: $A_{zy4,100}=10.63$ m² $A_{zy4,200}=10.63$ m² $A_{zy4,300}=9.22$ m²</p> <p>Analiza opterećenja: Stalno: $g_{100}=6.07$ kN/m² $g_{200}=5.30$ kN/m² $g_{300}=5,30$ kN/m² Pokretno: $q_{100}=1.50$ kN/m² $q_{200}=1.50$ kN/m² $q_{300}=1.50$ kN/m² Vlastita težina zida ($t=0,30m$): $g_z=3.60$ kN/m²</p>	<p>Proračun zida na vertikalna opterećenja:</p> <p>Uzdužna sila od stalnog djelovanja: $N_g=A_{zy4,100}*g_{100}+ A_{zy4,200}*g_{200}+ A_{zy4,300}*g_{300}+L*h*g_z$ $N_g=9.22*6.07+10.63*5.30+10.63*5,30+6.85*8,6*3,6$ $N_g=380.72$ kN</p> <p>Uzdužna sila od pokretnog djelovanja: $N_q=A_{zy4,100}*q_{100}+ A_{zy4,200}*q_{200}+ A_{zy4,300}*q_{300}$ $N_q=9.22*1.50+10.63*1.50+10.63*1.50$ $N_q=45.72$ kN</p> <p>Računska uzdužna sila: $N_{sd}=1.35*N_g+1.5*N_q$ $N_{sd}=1.35*380.72+1.5*45.72= 582.55$ kN</p> <p>Računska otpornost: $N_{Rd}=\phi_{i,m} * A * f_k / \gamma_M$ $N_{Rd}=0.7*(685*30)*0.366/2.2= 2393$ kN > 582.6 kN</p>
---	---

3.2 Proračun zidova na potres

3.2.1. Djelovanje potresa (S)

Temeljni zahtjevi nosivih konstrukcija na potres su da se proračunavaju na bazi linearno elastičnog ponašanja konstrukcije. Konstrukcija mora imati dovoljnu stabilnost za moguće kombinacije opterećenja (prevrtanje i klizanje). Prema EN 1998 gibanje u nekoj točki na površini općenito se prikazuje elastičnim spektrom odaziva tla koji se naziva „elastičnim spektrom odgovora“. EC 1998 ima dva bitna zahtjeva za sve vrste konstrukcija. Prvi zahtjev je da građevina se ne smije deformirati niti srušiti. Građevinu moramo proračunati i izgraditi tako da pri proračunskom djelovanju ne dođe do proklizavanja ili rušenja pojedinih dijelova građevine ili cijele građevine, nego da zadrži svoje prvobitno stanje konstrukcije u cijelosti nakon potresa. Drugi bitni zahtjev je da su ograničena oštećenja na konstrukciji. Građevinu moramo proračunati i izgraditi tako da se može oduprijeti potresnom djelovanju, čija je vjerojatnost pojave veća nego u proračunskom potresnom djelovanju, te da se ne pojave oštećenja i ograničenja u upotrebi, tako da bi trošak bio velik u odnosu same građevine. Razlikovanje po pouzdanosti je uključeno preko razreda važnosti građevine u faktoru važnosti γ_I . Predmetna građevina ima faktor važnosti 1,0.

Razredi važnosti građevine

Razred važnosti	Opis i namjena zgrade	Faktor važnosti zgrade γ_I
I	Zgrade manje važnosti za javnu sigurnost	0,8
II	Zgrade čija je potresna otpornost važna zbog posljedica vezanih uz rušenje	1,2
III	Obične zgrade koje ne pripadaju drugim razredima	1,0
IV	Zgrade čija je cjelovitost neposredno nakon potresa životno važna za zaštitu ljudi.	1,4

Predmetna građevina se računa prema razredu važnosti III. Građevina se proračunava na horizontalno potresno djelovanje, koje se opisuje dvjema okomitim komponentama S_x i S_y koja djeluje neovisno, u dvije međusobno okomite ravnine, a prikazane su istim spektrom odziva. Vrijednosti za ove sile proračunavaju se uporabom računskog spektra i ukupne težine, pri čemu rabimo pojednostavljenu spektralnu analizu prema EC8.

3.2.2. Kategorija temeljnog tla

Utjecaj lokalnih zahtjeva koji se odnose na tlo, potresno djelovanje općenito se uzima u obzir razmatranjem kategorija tla. EN 1998 razlikuje se više kategorija tla, a za predmetnu građevinu usvojena je klasa tla B. Kategorija B opisana je sljedećim geotehničkim profilom: Kruti nanosi pijeska, šljunka ili prekonsolidirane gline, debljine najmanje nekoliko desetaka metara, sa svojstvom postupnog povećanja mehaničkih svojstava s dubinom i brzinom v_s najmanje 200 m/s pri dubini od 10 metara.

3.2.3. Računsko ubrzanje tla

Potresno djelovanje određujemo iz računskog ubrzanja tla a_g koje odgovara povratnom periodu potresa od 475 godina. Prema seizmičkoj karti za područje Splita koja se nalazi prema HRN u VIII. seizmičkoj zoni, te se prema EC8 uzima računsko ubrzanje tla $o_{a_g}=0.23$ g. Projektni potres je najjači očekivani potres koji može pogoditi objekt u tijeku njegova amortizacijskog razdoblja, a usvaja se onaj potres koji se javlja jednom u 500 godina.

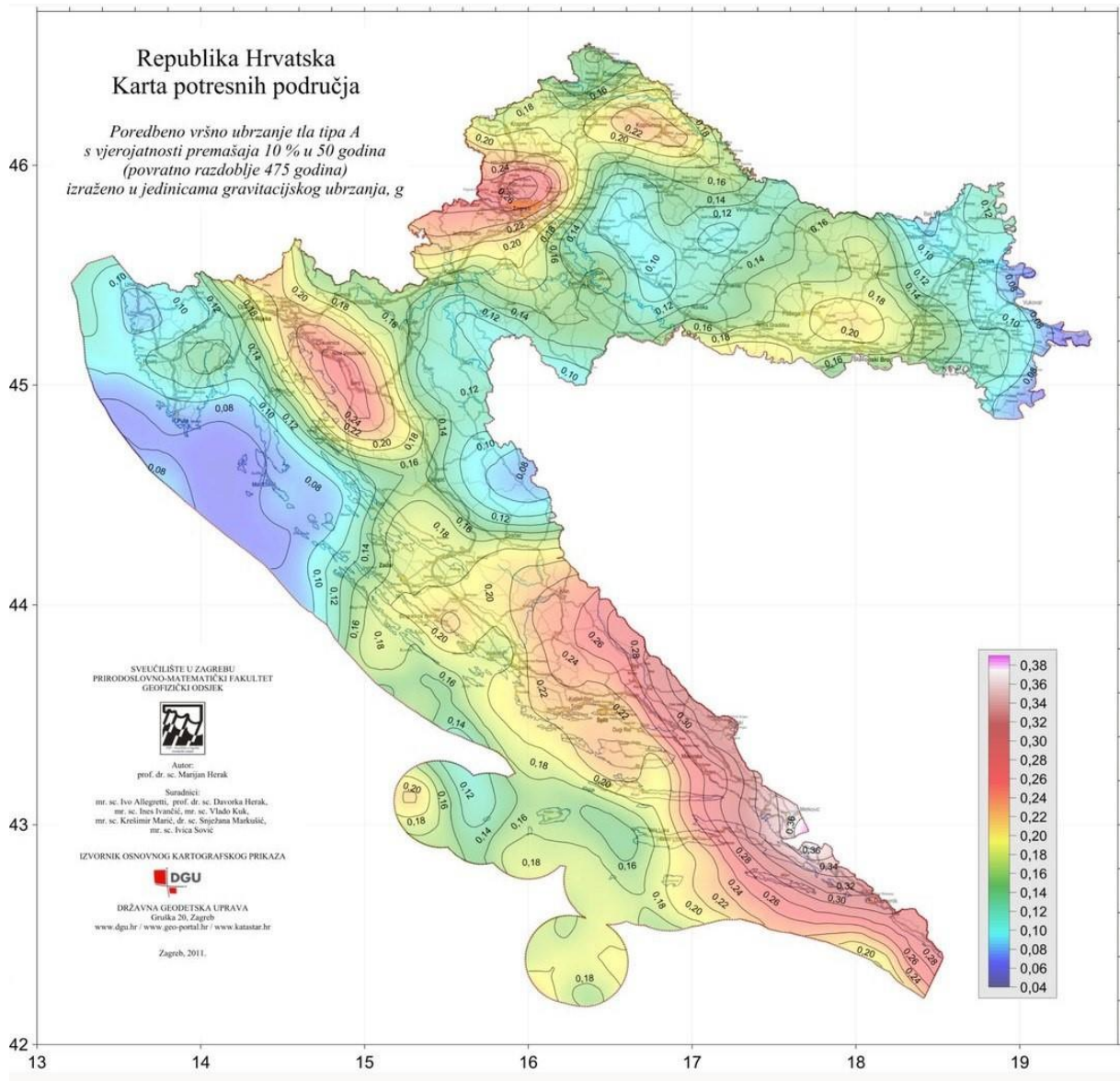

3.2.4. Proračun ukupne potresne poprečne sile

Ukupna potresna poprečna sila iznosi:

$$F_b = \gamma_I * S_d(T_1) * W$$

gdje je:

$S_d(T_1)$ = ordinata računskog spektra za period T_1

γ_I – faktor važnosti građevine ($\gamma_I=1.0$)

$$S_d(T_1) = \alpha * S^{2.5}/q$$

$\alpha = a_g/g = 2.3/10 = 0.23$ $S = 1.2$ (B kategorija tla)

$q = 2.5$ (faktor ponašanja konstrukcije)

$$S_d(T_1) = 0.23 * 1.2 * 2.5 / 2.5 = 0.27$$

W = računska težina zgrade:

3. ETAŽA I POZ 300:

$$\text{POZ 300: } (g + \phi * \psi_{2i} q) * A = (5.30 + 1.0 * 0.3 * 1.5) * 95.92 = 551.54 \text{ kN}$$

$$\text{Grede i nadvoji 300: } b * h * L_{uk} * \gamma_c = (0.3 * 0.4 * 11.9 + 0.3 * 0.25 * 5.8) * 25.0 = 46.58 \text{ kN}$$

$$\text{zidovi 3. etaže: } g_z * h_z * L_{uk} = 3.6 * 3.2 * 42.4 = 488.5 \text{ kN}$$

$$W_3 = 1086.62 \text{ kN}$$

2. ETAŽA I POZ 200:

$$\text{POZ 200: } (g + \phi * \psi_{2i} q) * A = (5.30 + 0.5 * 0.3 * 1.5) * 95.92 = 529.96 \text{ kN}$$

$$\text{Grede i nadvoji 200: } b * h * L_{uk} * \gamma_c = (0.3 * 0.4 * 11.9 + 0.3 * 0.25 * 5.8) * 25.0 = 46.58 \text{ kN}$$

$$\text{zidovi 2. etaže: } g_z * h_z * L_{uk} = 3.6 * 2.7 * 42.4 = 412.13 \text{ kN}$$

$$W_2 = 988.67 \text{ kN}$$

1. ETAŽA I POZ 100:

$$\text{POZ 100: } (g + \phi * \psi_{2i} q) * A = (6.07 + 0.5 * 0.3 * 1.5) * 95.92 = 603.82 \text{ kN}$$

$$\text{Grede i nadvoji 100: } b * h * L_{uk} * \gamma_c = (0.3 * 0.4 * 11.9 + 0.3 * 0.25 * 8.8) * 25.0 = 46.58 \text{ kN}$$

$$\text{zidovi 1. etaže: } g_z * h_z * L_{uk} = 3.6 * 2.7 * 42.4 = 412.13 \text{ kN}$$

$$W_1 = 1062.53 \text{ kN}$$

Izračun težina skoncentriranih u razini međukatnih konstrukcija:

$$W_{300} = W_3 = 1086.62 \text{ kN}$$

$$W_{200} = W_2 = 988.67 \text{ kN}$$

$$W_{100} = W_1 = 1062.53 \text{ kN}$$

Ukupna računaska težina zgrade:

$$W = 1062.53 + 988.67 + 1086.62 = 3137.82 \text{ kN}$$

Specifična računaska težina zgrade: $w = (W_1 + W_2 + W_3) / A_{uk} = 3137.82 / (95.92 * 3) = 10,9$
kN/m²

Ukupna potresna poprečna sila iznosi:

$$F_b = 0.27 * 3137.82 = 847.21 \text{ kN}$$

Razdioba ukupne potresne sile po etažama

$$F_{b,100} = F_b * (W_{100} * h_{100}) / (W_{100} * h_{100} + W_{200} * h_{200} + W_{300} * h_{300})$$

$$F_{b,100} = 847.21 * (1062.53 * 2.7) / (1062.53 * 2.7 + 988.67 * 5.4 + 1086.62 * 8.1) = 142.89 \text{ kN}$$

$$F_{b,200} = F_b * (W_{200} * h_{200}) / (W_{100} * h_{100} + W_{200} * h_{200} + W_{300} * h_{300})$$

$$F_{b,200} = 847.21 * (988.67 * 5.4) / (1062.53 * 2.7 + 988.67 * 5.4 + 1086.62 * 8.1) = 265.92 \text{ kN}$$

$$F_{b,300} = F_b * (W_{300} * h_{300}) / (W_{100} * h_{100} + W_{200} * h_{200} + W_{300} * h_{300})$$

$$F_{b,300} = 847.21 * (1086.62 * 8.1) / (1062.53 * 2.7 + 988.67 * 5.4 + 1086.62 * 8.1) = 438.40 \text{ kN}$$

Ukupna potresna poprečna sila:

$$V_{Ed} = 847.21 \text{ kN}$$

Ukupan moment savijanja:

$$M_{Ed} = F_{b,100} * h_{100} + F_{b,200} * h_{200} + F_{b,300} * h_{300}$$

$$M_{Ed} = 142.89 * 2.7 + 265.92 * 2.7 * 2 + 438.4 * 2.7 * 3 = 5372.81 \text{ kNm}$$

Razdioba ukupne potresne sile po zidovima

Ukupna potresna poprečna sila:

$$V_{Ed} = 847.21 \text{ kN}$$

Početna krutost zida bez otvora:

$$K_e = \frac{GA}{1.2h \left[1 + \alpha \frac{G}{E} \left(\frac{h}{L} \right)^2 \right]}$$

$E \cong$ modul elastičnosti: $1000f_k$

G = modul posmika ($G \approx E/6$)

t = debljina zida

h = svjetla visina zida

L = duljina zida

A = površina zida ($A=t \times L$)

α = proračunski koeficijent za punu upetost na gornjem i donjem katu $\alpha = 0.83$ za konzolni zid $\alpha = 3.33$

Početna krutost zida s otvorima za prozore

$$K_{e,otv.} = K_e \times k_1$$

$$k_1 = 1 - \frac{t \sum L_i}{0.85A}$$

$\sum L_i$ = zbroj duljina svih otvora u zidu

A = površina zida ($A=t \times L$)

$$V_{Ed,ix} = V_{Ed} \cdot K_{ix} / \sum K_{ix}$$

$$V_{Ed,iy} = V_{Ed} \cdot K_{iy} / \sum K_{iy}$$

F_b	847.21	kN	Ukupna sila od potresa
M_b	5372.81	kNm	Ukupan moment od potresa
E	3660	MPa	Modul elastičnosti
G	610	MPa	Modul posmika
f_k	3.66	MPa	Tlačna čvrstoća zida
γ_M	1.5		Parcijalni faktor sigurnosti za ziđe
γ_S	1.15		Parcijalni faktor sigurnosti za čelik
h	2.47	m	Svijetla visina zida
α	3.33	m	

ZID	debljina zida t [m]	duljina zida L [m]	površina zida A [m ²]	Σduljina otvora Li [m ²]	visina zida H [m]	početna krutost bez otvora K _e	krutost k ₁	krutost sa otvorima K _{e,otv}	poprečna sila V _{Sd} [kN]	moment M _{Sd} [kNm]	
ZX1	0.3	1.7	0.51	0.0	8.6	48.33	1.00	48.33	48.03	302.69	
ZX2	0.3	2.4	0.72	0.0	8.6	93.32	1.00	93.32	92.74	588.11	
ZX3	0.3	1.7	0.51	0.0	8.6	48.33	1.00	48.33	48.33	302.69	
ZX4	0.3	2.2	0.66	0.0	8.6	79.92	1.00	79.92	79.42	503.67	
ZX5	0.3	1.05	0.32	0.0	8.6	16.18	1.00	16.18	16.08	101.97	
ZX6	0.3	4.05	1.22	0.0	8.6	208.12	1.00	208.12	206.82	1311.60	
ZX7	0.3	8.9	2.67	2.4	8.6	526.97	0.68	358.34	356.10	2258.30	
									852.54	847.21	5372.81

ZID	debljina zida t [m]	duljina zida L [m]	površina zida A [m ²]	duljina otvora Li [m ²]	visina zida H [m]	početna krutost bez otvora K _e	krutost k ₁	krutost sa otvorima K _{e,otv}	poprečna sila V _{Sd} [kN]	moment M _{Sd} [kNm]	
ZY1	0.3	3.55	1.07	0.0	8.6	173.57	1.00	173.57	167.34	1061.21	
ZY2	0.3	3.55	1.07	0.0	8.6	173.57	1.00	173.57	167.34	1061.21	
ZY3	0.3	5.35	1.61	1.2	8.6	296.29	0.74	219.25	211.38	1340.50	
ZY4	0.3	6.85	2.06	1.2	8.6	395.42	0.79	312.38	301.16	1909.89	
									878.77	847.21	5372.81

3.2.5. Proračun zidova na potres

Podaci za proračun zidova:

tlačna čvrstoća ziđa:

$$f_k = K * f_b^{0.7} * f_m^{0.3} = 0.45 * 10^{0.7} * 5^{0.3} = 3.66 \text{ MPa}$$

parcijalni koef. sigurnosti za materijale: $\gamma_M = 1.5$

karakteristična posmična čvrstoća:

$$f_{vk} = f_{vk0} + 0.4 * \sigma_d = f_{vk} < 0.065 * f_b = 0.065 * 10 = 0.65 \text{ MPa}$$

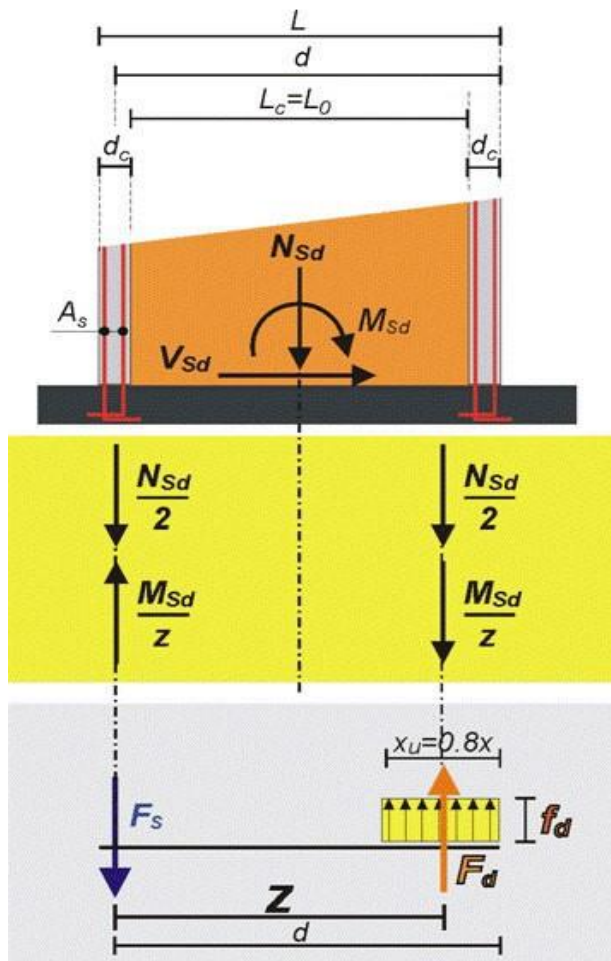

U proračunu zidova na potres dokazuje se da je:

$$1/ \quad V_{Sd} < V_{Rd}$$

računska poprečna sila: V_{Sd}

računska nosivost na poprečnu silu:

$$V_{Rd} = A * f_{vk} / \gamma_M = x_u * t * f_{vk} / \gamma_M$$

$$2/ \quad F_d < F_{Rd}$$

računska tlačna sila na rubu:

$$F_d = M_{Sd} / z + N_{Sd} / 2$$

računska uzdužna sila:

$$N_{Sd} = (N_g + N_q \psi_{2i}) \text{ računski moment}$$

savijanja: M_{Sd}

z = krak unutarnjih sila;

$z \approx 0.8 * d$ računski nosivost na

tlačnu silu na rubu:

$$F_{Rd} = x_u * t * f_k / \gamma_m$$

$$x_u = 2(d-z) \approx 0.4 * d$$

$$\gamma_m = 1.5$$

Potrebna površina armature vertikalnih serklaža:

$$3/ \quad A_{s1} = F_s / f_{yd} [\text{cm}^2]$$

računska vlačna sila: $F_s = M_{Sd} / z - N_{Sd} / 2$

$$f_{yd} = f_{yk} / \gamma_s$$

$$f_{yk} = 500 \text{ MPa}; \quad \gamma_s = 1.15$$

Zid ZX1

<p>Geometrijske karakteristike zida: duljina zida: $L=1.7$ m debljina zida: $t=0.3$ m statička visina: $d=L-t/2$ $d=1.7-0.3/2=1.55$ m krak sila: $z=0.8*d=0.8*1.55=1.24$ m duljina zida u tlaku: $x_u=2*(d-z)=2*(1.55-1.24)=0.62$ m</p> <p>Mehaničke karakteristike zida: tlačna čvrstoća: $f_k=3.66$ MPa osnovna posmična čvrstoća: $f_{vk0}=0.3$ MPa Unutarnje sile: Poprečna sila: $V_{sd}=48.03$ kN Moment: $M_{sd}=302.69$ kNm Uzdužna sila: $N_{sd}=N_g+0.3*N_q=119.13+0.3*18.14$ $N_{sd}=124.57$ kN</p>	<p>Proračun zida na potres: Dokaz nosivosti u tlaku: $F_d=N_{sd}/2+M_{sd}/z=124.57/2+302.69/1.24=306.39$ kN $F_{Rd}=f_k*t*x_u/\gamma_M=(3.66/10)*30*62/1.5=453.84$ kN > 306.39 kN</p> <p>Armatura vertikalnog serklaža: vlačna sila: $F_s=(M_{sd}/z-N_{sd}/2)=302.69/1.24-124.57/2=181.81$ kN $A_s=F_s/f_{yd}=181.81/(50/1.15)=4.18$ cm²</p> <p>Nosivost na poprečnu silu: $f_{vk}=f_{vk0}+0.4\sigma_m=0.3+0.4*F_d/(t*x_u)$ $f_{vk}=0.3+0.4*306.39/(0.3*0.62)/1000=0.96$ MPa > $0.065 * f_b = 0.065*10 = 0.65$ MPa $V_{Rd}=f_{vk}*x_u*t/\gamma_M=0.65*62*30/1.5/10=80.6$ kN > 48.03 kN</p>
---	--

Zid ZX2

<p>Geometrijske karakteristike zida: duljina zida: $L=2.4$ m debljina zida: $t=0.3$ m statička visina: $d=L-0.3/2$ $d=2.4-0.3/2=2.25$ m krak sila: $z=0.8*d=0.8*2.25=1.8$ m duljina zida u tlaku: $x_u=2*(d-z)=2*(2.25-1.8)=0.9$ m</p> <p>Mehaničke karakteristike zida: tlačna čvrstoća: $f_k=3.66$ MPa osnovna posmična čvrstoća: $f_{vk0}=0.3$ MPa Unutarnje sile: Poprečna sila: $V_{sd}=92.74$ kN Moment: $M_{sd}=588.11$ kNm Uzdužna sila: $N_{sd}=N_g+0.3*N_q=204.33+0.3*35.1$ $N_{sd}=214.86$ kN</p>	<p>Proračun zida na potres: Dokaz nosivosti u tlaku: $F_d=N_{sd}/2+M_{sd}/z=214.86/2+588.11/1.8=434.16$ kN $F_{Rd}=f_k*t*x_u/\gamma_M=(3.66/10)*30*90/1.5=658.8$ kN > 434.16 kN</p> <p>Armatura vertikalnog serklaža: vlačna sila: $F_s=(M_{sd}/z-N_{sd}/2)=588.11/1.8-214.86/2=219.30$ kN $A_s=F_s/f_{yd}=219.3/(50/1.15)=5.04$ cm²</p> <p>Nosivost na poprečnu silu: $f_{vk}=f_{vk0}+0.4\sigma_m=0.3+0.4*F_d/(t*x_u)$ $f_{vk}=0.3+0.4*434.16/(0.3*0.9)/1000=0.94$ MPa $> 0.065 * f_b = 0.065*10 = 0.65$ MPa $V_{Rd}=f_{vk}*x_u*t/\gamma_M=0.65*90*30/1.5/10=117$ kN > 92.74 kN</p>
---	--

Zid ZX3

<p>Geometrijske karakteristike zida: duljina zida: $L=1.7$ m debljina zida: $t=0.3$ m statička visina: $d=L-t/2$ $d=1.7-0.3/2=1.55$ m krak sila: $z=0.8*d=0.8*1.55=1.24$ m duljina zida u tlaku: $x_u=2*(d-z)=2*(1.55-1.24)=0.62$ m</p> <p>Mehaničke karakteristike zida: tlačna čvrstoća: $f_k=3.66$ MPa osnovna posmična čvrstoća: $f_{vk0}=0.3$ MPa Unutarnje sile: Poprečna sila: $V_{sd}=48.03$ kN Moment: $M_{sd}=302.69$ kNm Uzdužna sila: $N_{sd}=N_g+0.3*N_q=119.13+0.3*18.14$ $N_{sd}=124.57$ kN</p>	<p>Proračun zida na potres: Dokaz nosivosti u tlaku: $F_d=N_{sd}/2+M_{sd}/z=124.57/2+302.69/1.24=306.39$ kN $F_{Rd}=f_k*t*x_u/\gamma_M=(3.66/10)*30*62/1.5=453.84$ kN > 306.39 kN</p> <p>Armatura vertikalnog serklaža: vlačna sila: $F_s=(M_{sd}/z-N_{sd}/2)=302.69/1.24-124.57/2=181.81$ kN $A_s=F_s/f_{yd}=181.81/(50/1.15)=4.18$ cm²</p> <p>Nosivost na poprečnu silu: $f_{vk}=f_{vk0}+0.4\sigma_m=0.3+0.4*F_d/(t*x_u)$ $f_{vk}=0.3+0.4*306.39/(0.3*0.62)/1000=0.96$ MPa > $0.065 * f_b = 0.065*10 = 0.65$ MPa $V_{Rd}=f_{vk}*x_u*t/\gamma_M=0.65*62*30/1.5/10=80.6$ kN > 48.03 kN</p>
---	--

Zid ZX4

<p>Geometrijske karakteristike zida: duljina zida: $L=2.2$ m debljina zida: $t=0.3$ m statička visina: $d=L-t/2$ $d=2.2-0.3/2=2.05$ m krak sila: $z=0.8*d=0.8*2.05=1.64$ m duljina zida u tlaku: $x_u=2*(d-z)=2*(2.05-1.64)=0.82$ m</p> <p>Mehaničke karakteristike zida: tlačna čvrstoća: $f_k=3.66$ MPa osnovna posmična čvrstoća: $f_{vk0}=0.3$ MPa Unutarnje sile: Poprečna sila: $V_{sd}=79.42$ kN Moment: $M_{sd}=503.67$ kNm Uzdužna sila: $N_{sd}=N_g+0.3*N_q=327.15+0.3*70.11$ $N_{sd}=348.18$ kN</p>	<p>Proračun zida na potres: Dokaz nosivosti u tlaku: $F_d=N_{sd}/2+M_{sd}/z=348.18/2+503.67/1.64=481.21$ kN $F_{Rd}=f_k*t*x_u/\gamma_M=(3.66/10)*30*82/1.5=600.24$ kN > 481.21 kN</p> <p>Armatura vertikalnog serklaža: vlačna sila: $F_s=(M_{sd}/z-N_{sd}/2)=503.67/1.64-348.18/2=133.03$ kN $A_s=F_s/f_{yd}=103.03/(50/1.15)=2.37$ cm²</p> <p>Nosivost na poprečnu silu: $f_{vk}=f_{vk0}+0.4\sigma_m=0.3+0.4*F_d/(t*x_u)$ $f_{vk}=0.3+0.4*481.21/(0.3*0.82)/1000=1.08$ MPa > $0.065 * f_b = 0.065*10 = 0.65$ MPa $V_{Rd}=f_{vk}*x_u*t/\gamma_M=0.65*82*30/1.5/10=106.6$ kN > 79.42 kN</p>
--	---

Zid ZX5

<p>Geometrijske karakteristike zida: duljina zida: $L=1.05\text{m}$ debljina zida: $t=0.3\text{ m}$ statička visina: $d=L-t/2$ $d=1.05-0.3/2=0.9\text{ m}$ krak sila: $z=0.8*d=0.8*0.9=0.72\text{ m}$ duljina zida u tlaku: $x_u=2*(d-z)=2*(0.9-0.72)=0.36\text{ m}$</p> <p>Mehaničke karakteristike zida: tlačna čvrstoća: $f_k=25\text{ MPa}$ osnovna posmična čvrstoća: $f_{vk0}=0.3\text{ MPa}$ Unutarnje sile: Poprečna sila: $V_{sd}=16.08\text{ kN}$ Moment: $M_{sd}=101.97\text{kNm}$ Uzdužna sila: $N_{sd}=N_g+0.3*N_q=246.99+0.3*57.68$ $N_{sd}=264.29\text{ kN}$</p>	<p>Proračun zida na potres: Dokaz nosivosti u tlaku: $F_d=N_{sd}/2+M_{sd}/z=264.29/2+101.97/0.72=273.82\text{ kN}$ $F_{Rd}=f_k*t*x_u/\gamma_M=(25/10)*30*36/1.5=1800\text{kN}>273.82\text{kN}$</p> <p>Armatura vertikalnog serklaža: vlačna sila: $F_s=(M_{sd}/z-N_{sd}/2)=101.97/0.72-264.29/2=9.52\text{ kN}$ $A_s=F_s/f_{yd}=9.52/(50/1.15)=0.22\text{ cm}^2$</p> <p>Nosivost na poprečnu silu: $f_{vk}=f_{vk0}+0.4\sigma_m=0.3+0.4*F_d/(t*x_u)$ $f_{vk}=0.3+0.4*273.82/(0.3*0.36)/1000=1.31\text{ MPa}$ $>0.065*f_b=0.065*10=0.65\text{ MPa}$ $V_{Rd}=f_{vk}*x_u*t/\gamma_M=0.65*36*30/1.5/10=46.8\text{ kN}>16.08\text{ kN}$</p>
---	--

Zid ZX6

<p>Geometrijske karakteristike zida: duljina zida: $L=4.05$ m debljina zida: $t=0.3$ m statička visina: $d=L-t/2$ $d=4.05-0.3/2=3.90$ m krak sila: $z=0.8*d=0.8*3.9=3.12$ m duljina zida u tlaku: $x_u=2*(d-z)=2*(3.9-3.12)=1.56$ m</p> <p>Mehaničke karakteristike zida: tlačna čvrstoća: $f_k=3.66$ MPa osnovna posmična čvrstoća: $f_{vk0}=0.3$ MPa Unutarnje sile: Poprečna sila: $V_{sd}=206.82$ kN Moment: $M_{sd}=1311.60$ kNm Uzdužna sila: $N_{sd}=N_g+0.3*N_q=432.62+0.3*83.13$ $N_{sd}=457.56$ kN</p>	<p>Proračun zida na potres: Dokaz nosivosti u tlaku: $F_d=N_{sd}/2+M_{sd}/z=457.56/2+1311.60/3.12=649.16$ kN $F_{Rd}=f_k*t*x_u/\gamma_M=(3.66/10)*30*156/1.5=1141.92$ kN > 649.16 kN</p> <p>Armatura vertikalnog serklaža: vlačna sila: $F_s=(M_{sd}/z-N_{sd}/2)=1311.60/3.12-457.56/2=191.6$ kN $A_s=F_s/f_{yd}=191.6/(50/1.15)=4.41$ cm²</p> <p>Nosivost na poprečnu silu: $f_{vk}=f_{vk0}+0.4\sigma_m=0.3+0.4*F_d/(t*x_u)$ $f_{vk}=0.3+0.4*649.16/(0.3*1.56)/1000=0.79$ MPa > $0.065 * f_b =$ $0.065*10 = 0.65$ MPa $V_{Rd}=f_{vk}*x_u*t/\gamma_M=0.65*156*30/1.5/10=212.8$ kN > 206.82 kN</p>
--	--

Zid ZX7

<p>Geometrijske karakteristike zida: duljina zida: $L=8.9$ m debljina zida: $t=0.3$ m statička visina: $d=L-0.25/2$ $d=8.9-0.3/2=8.75$ m krak sila: $z=0.8*d=0.8*8.75=7.0$ m duljina zida u tlaku: $x_u=2*(d-z)=2*(8.75-7.0)=3.5$ m</p> <p>Mehaničke karakteristike zida: tlačna čvrstoća: $f_k=3.66$ MPa osnovna posmična čvrstoća: $f_{vk0}=0.3$ MPa Unutarnje sile: Poprečna sila: $V_{sd}=356.1$ kN Moment: $M_{sd}=2258.30$ kNm Uzdužna sila: $N_{sd}=N_g+0.3*N_q=498.7+0.3*60.63$ $N_{sd}=516.89$ kN</p>	<p>Proračun zida na potres: Dokaz nosivosti u tlaku: $F_d=N_{sd}/2+M_{sd}/z=516.89/2+2258.30/7=581.06$ kN $F_{Rd}=f_k*t*x_u/\gamma_M=(3.66/10)*30*350/1.5=2562$ kN >581.06 kN</p> <p>Armatura vertikalnog serklaža: vlačna sila: $F_s=(M_{sd}/z-N_{sd}/2)=2258.30/7-516.89/2=64.17$ kN $A_s=F_s/f_{yd}=64.17/(50/1.15)=1.47$ cm²</p> <p>Nosivost na poprečnu silu: $f_{vk}=f_{vk0}+0.4*\sigma_m=0.3+0.4*F_d/(t*x_u)$ $f_{vk}=0.3+0.4*581.06/(0.3*3.5)/1000=0.52$ MPa $<0.065*f_b=0.065*10=0.65$ MPa $V_{Rd}=f_{vk}*x_u*t/\gamma_M=0.65*350*30/1.5/10=455$ kN >356.1 kN</p>
--	--

Zid ZY1

<p>Geometrijske karakteristike zida: duljina zida: $L=3.55$ m debljina zida: $t=0.3$ m statička visina: $d=L-t/2$ $d=3.55-0.3/2=3.40$ m krak sila: $z=0.8*d=0.8*3.4=2.72$ m duljina zida u tlaku: $x_u=2*(d-z)=2*(3.40-2.72)=1.36$ m</p> <p>Mehaničke karakteristike zida: tlačna čvrstoća: $f_k=3.66$ MPa osnovna posmična čvrstoća: $f_{vk0}=0.3$ MPa Unutarnje sile: Poprečna sila: $V_{sd}=167.34$ kN Moment: $M_{sd}=1061.21$ kNm Uzdužna sila: $N_{sd}=N_g+0.3*N_q=125.93+0.3*4$ $N_{sd}=127.13$ kN</p>	<p>Proračun zida na potres: Dokaz nosivosti u tlaku: $F_d=N_{sd}/2+M_{sd}/z=127.13/2+1061.21/2.72=453.72$ kN $F_{Rd}=f_k*t*x_u/\gamma_M=(3.66/10)*30*136/1.5=995.52$ kN >453.72 kN</p> <p>Armatura vertikalnog serklaža: vlačna sila: $F_s=(M_{sd}/z-N_{sd}/2)=1061.21/2.72-127.13/2=326.59$ kN $A_s=F_s/f_{yd}=326.59/(50/1.15)=7.5$ cm²</p> <p>Nosivost na poprečnu silu: $f_{vk}=f_{vk0}+0.4\sigma_m=0.3+0.4*F_d/(t*x_u)$ $f_{vk}=0.3+0.4*453.72/(0.3*1.36)/1000=0.68$ MPa $\cong 0.065 * f_b = 0.065*10 = 0.65$ MPa $V_{Rd}=f_{vk}*x_u*t/\gamma_M=0.65*136*30/1.5/10=176.8$ kN >167.34 kN</p>
---	--

Zid ZY2

<p>Geometrijske karakteristike zida: duljina zida: $L=3.55$ m debljina zida: $t=0.3$ m statička visina: $d=L-t/2$ $d=3.55-0.3/2=3.40$ m krak sila: $z=0.8*d=0.8*3.4=2.72$ m duljina zida u tlaku: $x_u=2*(d-z)=2*(3.40-2.72)=1.36$ m</p> <p>Mehaničke karakteristike zida: tlačna čvrstoća: $f_k=3.66$ MPa osnovna posmična čvrstoća: $f_{vk0}=0.3$ MPa Unutarnje sile: Poprečna sila: $V_{sd}=167.34$ kN Moment: $M_{sd}=1061.21$ kNm Uzdužna sila: $N_{sd}=N_g+0.3*N_q=125.93+0.3*4$ $N_{sd}=127.13$ kN</p>	<p>Proračun zida na potres: Dokaz nosivosti u tlaku: $F_d=N_{sd}/2+M_{sd}/z=127.13/2+1061.21/2.72=453.72$ kN $F_{Rd}=f_k*t*x_u/\gamma_M=(3.66/10)*30*136/1.5=995.52$ kN >453.72 kN</p> <p>Armatura vertikalnog serklaža: vlačna sila: $F_s=(M_{sd}/z-N_{sd}/2)=1061.21/2.72-127.13/2=326.59$ kN $A_s=F_s/f_{yd}=326.59/(50/1.15)=7.5$ cm²</p> <p>Nosivost na poprečnu silu: $f_{vk}=f_{vk0}+0.4\sigma_m=0.3+0.4*F_d/(t*x_u)$ $f_{vk}=0.3+0.4*453.72/(0.3*1.36)/1000=0.68$ MPa $\cong 0.065 * f_b = 0.065*10 = 0.65$ MPa $V_{Rd}=f_{vk}*x_u*t/\gamma_M=0.65*136*30/1.5/10=176.8$ kN >167.34 kN</p>
---	--

Zid ZY3

<p>Geometrijske karakteristike zida: duljina zida: $L=5.35$ m debljina zida: $t=0.3$ m statička visina: $d=L-t/2$ $d=5.35-0.3/2=5.2$ m krak sila: $z=0.8*d=0.8*5.2=4.16$ m duljina zida u tlaku: $x_u=2*(d-z)=2*(5.20-4.16)= 2.08$ m</p> <p>Mehaničke karakteristike zida: tlačna čvrstoća: $f_k=3.66$ MPa osnovna posmična čvrstoća: $f_{vk0}=0.3$ MPa Unutarnje sile: Poprečna sila: $V_{sd}=211.38$ kN Moment: $M_{sd}=1340.50$ kNm Uzdužna sila: $N_{sd}=N_g+0.3*N_q=219.37+0.3*14.32$ $N_{sd}=223.67$ kN</p>	<p>Proračun zida na potres: Dokaz nosivosti u tlaku: $F_d=N_{sd}/2+M_{sd}/z=223.67/2+1340.50/4.16= 434.07$ kN $F_{Rd}=f_k*t*x_u/\gamma_M=(3.66/10)*30*208/1.5=1522.56$ kN > 434 kN</p> <p>Armatura vertikalnog serklaža: vlačna sila: $F_s=(M_{sd}/z-N_{sd}/2)= 1340.50/4.16-223.67/2= 210.4$ kN $A_s=F_s/f_{yd}=210.4/(50/1.15)= 4.84$ cm²</p> <p>Nosivost na poprečnu silu: $f_{vk}= f_{vk0}+0.4\sigma_m=0.3+0.4*F_d/(t*x_u)$ $f_{vk}=0.3+0.4*434/(0.3*2.08)/1000=0.57$ MPa < $0.065 * f_b =$ $0.065*10 = 0.65$ MPa $V_{Rd}=f_{vk} * x_u * t / \gamma_M = 0.65 * 208 * 30 / 1.5 / 10 = 270.4$ kN > 211.38 kN</p>
---	---

Zid ZY4

<p>Geometrijske karakteristike zida: duljina zida: $L=6.85$ m debljina zida: $t=0.3$ m statička visina: $d=L-t/2$ $d=6.85-0.3/2=6.70$ m krak sila: $z=0.8*d=0.8*6.70=5.36$ m duljina zida u tlaku: $x_u=2*(d-z)=2*(6.70-5.36)=2.68$ m</p> <p>Mehaničke karakteristike zida: tlačna čvrstoća: $f_k=3.66$ MPa osnovna posmična čvrstoća: $f_{vk0}=0.3$ MPa Unutarnje sile: Poprečna sila: $V_{sd}=301.16$ kN Moment: $M_{sd}=1909.89$ kNm Uzdužna sila: $N_{sd}=N_g+0.3*N_q=380.72+0.3*45.72$ $N_{sd}=394.44$ kN</p>	<p>Proračun zida na potres: Dokaz nosivosti u tlaku: $F_d=N_{sd}/2+M_{sd}/z=394.44/2+1909.89/5.36=553.54$ kN $F_{Rd}=f_k*t*x_u/\gamma_M=(3.66/10)*30*268/1.5=1961.7$ kN > 553.54 kN</p> <p>Armatura vertikalnog serklaža: vlačna sila: $F_s=(M_{sd}/z-N_{sd}/2)=1909.89/5.36-394.44/2=159.1$ kN $A_s=F_s/f_{yd}=159.1/(50/1.15)=3.66$ cm²</p> <p>Nosivost na poprečnu silu: $f_{vk}=f_{vk0}+0.4\sigma_m=0.3+0.4*F_d/(t*x_u)$ $f_{vk}=0.3+0.4*553.54/(0.3*2.68)/1000=0.57$ MPa $< 0.065 * f_b = 0.065*10 = 0.65$ MPa $V_{Rd}=f_{vk}*x_u*t/\gamma_M=0.65*268*30/1.5/10=348.4$ kN > 301.16 kN</p>
--	--

4. PRORAČUN TEMELJA

TEMELJNA TRAKA U OSI 1

<p>Analiza opterećenja: Uzdužna sila u zidu ZX7 (L=8.9 m): stalno djelovanje: $N_g=499$ KN korisno djelovanje: $N_q=61$ KN</p> <p>Težina temeljne trake: (pretpostavka B/H=50 cm/50 cm): $N_{g,t}=B \cdot H \cdot L \cdot \gamma_B$ $N_{g,t}=0.5 \cdot 0.5 \cdot 8.9 \cdot 25= 56$ kN</p> <p>Računska uzdužna sila: $N_{sd}=1.35 \cdot (N_g + N_{g,t}) + 1.5 \cdot N_q$ $N_{sd}=1.35 \cdot (499 + 56) + 1.5 \cdot 61= 840$ kN $n_{sd}= N_{sd}/L=840/8.9= 95$ kN/m</p>	<p>Proračun širine temeljne trake: Dopuštena nosivost tla: $\sigma_{Rd}=300$ kPa Naprezanje u tlu: $\sigma_{sd} = n_{sd} / (B \cdot 1.0 \text{ m}) < \sigma_{Rd}$ Širina temeljne trake: $B > n_{sd} / \sigma_{Rd}$ $B > 95 / 300 = 0.31$ m (usvojeno 50 cm)</p>
---	---

TEMELJNA TRAKA U OSI 2

<p>Analiza opterećenja: Uzdužna sila u zidu ZX6 (L=8.9 m): stalno djelovanje: $N_g=433$ KN korisno djelovanje: $N_q=83$ KN</p> <p>Težina temeljne trake: (pretpostavka B/H=50 cm/50 cm): $N_{g,t}=B \cdot H \cdot L \cdot \gamma_B$ $N_{g,t}=0.5 \cdot 0.5 \cdot 8.9 \cdot 25= 56$ kN</p> <p>Računska uzdužna sila: $N_{sd}=1.35 \cdot (N_g + N_{g,t}) + 1.5 \cdot N_q$ $N_{sd}=1.35 \cdot (433 + 56) + 1.5 \cdot 83= 785$ kN $n_{sd}= N_{sd}/L=785/8.9= 88$ kN/m</p>	<p>Proračun širine temeljne trake: Dopuštena nosivost tla: $\sigma_{Rd}=300$ kPa Naprezanje u tlu: $\sigma_{sd} = n_{sd} / (B \cdot 1.0 \text{ m}) < \sigma_{Rd}$ Širina temeljne trake: $B > n_{sd} / \sigma_{Rd}$ $B > 88 / 300 = 0.29$ m (usvojeno 50 cm)</p>
---	---

TEMELJNA TRAKA U OSI 3

<p>Analiza opterećenja: Uzdužna sila u zidu ZX4, ZX5 (L=10.6 m): stalno djelovanje: $N_g=574$ KN korisno djelovanje: $N_q=128$ KN</p> <p>Težina temeljne trake: (pretpostavka B/H=50 cm/50 cm): $N_{g,t}=B \cdot H \cdot L \cdot \gamma_B$ $N_{g,t}=0.5 \cdot 0.5 \cdot 10.6 \cdot 25 = 66$ kN</p> <p>Računska uzdužna sila: $N_{sd}=1.35 \cdot (N_g + N_{g,t}) + 1.5 \cdot N_q$ $N_{sd}=1.35 \cdot (574 + 66) + 1.5 \cdot 128 = 989$ kN $n_{sd} = N_{sd}/L = 1056/10.6 = 100$ kN/m</p>	<p>Proračun širine temeljne trake:</p> <p>Dopuštena nosivost tla: $\sigma_{Rd}=300$ kPa Naprezanje u tlu: $\sigma_{sd} = n_{sd} / (B \cdot 1.0 \text{ m}) < \sigma_{Rd}$ Širina temeljne trake: $B > n_{sd} / \sigma_{Rd}$ $B > 100 / 300 = 30$ m (usvojeno 50 cm)</p>
--	--

TEMELJNA TRAKA U OSI 4

<p>Analiza opterećenja: Uzdužna sila u zidu ZX1, ZX2, ZX3 (L=10.60 m): stalno djelovanje: $N_g=443$ KN korisno djelovanje: $N_q=71$ KN</p> <p>Težina temeljne trake: (pretpostavka B/H=50 cm/50 cm): $N_{g,t}=B \cdot H \cdot L \cdot \gamma_B$ $N_{g,t}=0.5 \cdot 0.5 \cdot 10.6 \cdot 25 = 66$ kN</p> <p>Računska uzdužna sila: $N_{sd}=1.35 \cdot (N_g + N_{g,t}) + 1.5 \cdot N_q$ $N_{sd}=1.35 \cdot (443 + 66) + 1.5 \cdot 71 = 794$ kN $n_{sd} = N_{sd}/L = 794/10.6 = 75$ kN/m</p>	<p>Proračun širine temeljne trake:</p> <p>Dopuštena nosivost tla: $\sigma_{Rd}=300$ kPa Naprezanje u tlu: $\sigma_{sd} = n_{sd} / (B \cdot 1.0 \text{ m}) < \sigma_{Rd}$ Širina temeljne trake: $B > n_{sd} / \sigma_{Rd}$ $B > 75 / 300 = 0.25$ m (usvojeno 50 cm)</p>
--	---

TEMELJNA TRAKA U OSI A

<p>Analiza opterećenja: Uzdužna sila u zidu ZY3 (L=6.85 m): stalno djelovanje: $N_g=220$ KN korisno djelovanje: $N_q=14$ KN</p> <p>Težina temeljne trake: (pretpostavka B/H=50 cm/50 cm): $N_{g,t}=B \cdot H \cdot L \cdot \gamma_B$ $N_{g,t}=0.5 \cdot 0.5 \cdot 6.85 \cdot 25 = 43$ kN</p> <p>Računska uzdužna sila: $N_{sd}=1.35 \cdot (N_g + N_{g,t}) + 1.5 \cdot N_q$ $N_{sd}=1.35 \cdot (220+43) + 1.5 \cdot 14 = 376$ kN $n_{sd} = N_{sd}/L = 376/6.85 = 55$ kN/m</p>	<p>Proračun širine temeljne trake:</p> <p>Dopuštena nosivost tla: $\sigma_{Rd}=300$ kPa Naprezanje u tlu: $\sigma_{sd} = n_{sd} / (B \cdot 1.0 \text{ m}) < \sigma_{Rd}$ Širina temeljne trake: $B > n_{sd} / \sigma_{Rd}$ $B > 55 / 300 = 0.18$ m (usvojeno 50 cm)</p>
--	---

TEMELJNA TRAKA U OSI B

<p>Analiza opterećenja: Uzdužna sila u zidu ZY4 (L=6.85 m): stalno djelovanje: $N_g=381$ KN korisno djelovanje: $N_q=46$ KN</p> <p>Težina temeljne trake: (pretpostavka B/H=50 cm/50 cm): $N_{g,t}=B \cdot H \cdot L \cdot \gamma_B$ $N_{g,t}=0.5 \cdot 0.5 \cdot 6.85 \cdot 25 = 43$ kN</p> <p>Računska uzdužna sila: $N_{sd}=1.35 \cdot (N_g + N_{g,t}) + 1.5 \cdot N_q$ $N_{sd}=1.35 \cdot (381+43) + 1.5 \cdot 46 = 642$ kN $n_{sd} = N_{sd}/L = 642/6.85 = 94$ kN/m</p>	<p>Proračun širine temeljne trake:</p> <p>Dopuštena nosivost tla: $\sigma_{Rd}=300$ kPa Naprezanje u tlu: $\sigma_{sd} = n_{sd} / (B \cdot 1.0 \text{ m}) < \sigma_{Rd}$ Širina temeljne trake: $B > n_{sd} / \sigma_{Rd}$ $B > 94 / 300 = 0.31$ m (usvojeno 50 cm)</p>
--	---

TEMELJNA TRAKA U OSI C

<p>Analiza opterećenja: Uzdužna sila u zidu ZY1 (L=3.55 m): stalno djelovanje: $N_g=126$ KN korisno djelovanje: $N_q=4$ KN</p> <p>Težina temeljne trake: (pretpostavka B/H=50 cm/50 cm): $N_{g,t}=B \cdot H \cdot L \cdot \gamma_B$ $N_{g,t}=0.5 \cdot 0.5 \cdot 3.55 \cdot 25 = 22$ kN</p> <p>Računska uzdužna sila: $N_{sd}=1.35 \cdot (N_g + N_{g,t}) + 1.5 \cdot N_q$ $N_{sd}=1.35 \cdot (126 + 22) + 1.5 \cdot 4 = 206$ kN $n_{sd} = N_{sd}/L = 206/3.55 = 58$ kN/m</p>	<p>Proračun širine temeljne trake:</p> <p>Dopuštena nosivost tla: $\sigma_{Rd}=300$ kPa Naprezanje u tlu: $\sigma_{sd} = n_{sd} / (B \cdot 1.0 \text{ m}) < \sigma_{Rd}$ Širina temeljne trake: $B > n_{sd} / \sigma_{Rd}$ $B > 58 / 300 = 0.19$ m (usvojeno 50 cm)</p>
--	---

TEMELJNA TRAKA U OSI D

<p>Analiza opterećenja: Uzdužna sila u zidu ZY2 (L=3.55 m): stalno djelovanje: $N_g=126$ KN korisno djelovanje: $N_q=4$ KN</p> <p>Težina temeljne trake: (pretpostavka B/H=50 cm/50 cm): $N_{g,t}=B \cdot H \cdot L \cdot \gamma_B$ $N_{g,t}=0.5 \cdot 0.5 \cdot 3.55 \cdot 25 = 22$ kN</p> <p>Računska uzdužna sila: $N_{sd}=1.35 \cdot (N_g + N_{g,t}) + 1.5 \cdot N_q$ $N_{sd}=1.35 \cdot (126 + 22) + 1.5 \cdot 4 = 206$ kN $n_{sd} = N_{sd}/L = 206/3.55 = 58$ kN/m</p>	<p>Proračun širine temeljne trake:</p> <p>Dopuštena nosivost tla: $\sigma_{Rd}=300$ kPa Naprezanje u tlu: $\sigma_{sd} = n_{sd} / (B \cdot 1.0 \text{ m}) < \sigma_{Rd}$ Širina temeljne trake: $B > n_{sd} / \sigma_{Rd}$ $B > 58 / 300 = 0.19$ m (usvojeno 50 cm)</p>
--	---

5. LITERATURA

1. Sorić, Z. Zidane konstrukcije I., Građevinski fakultet Sveučilišta u Zagrebu, Zagreb, 2004
2. Eurocode 1 – Actions on structures; Part 1-1: Densities, self-weight, imposed loads for buildings
3. Eurocode 2 – Design of Concrete Structures, Part 1; General Rules and Rules for Buildings, Revised final draft, Brussels, October 1990.
4. Eurocode 6 – Projektiranje zidanih konstrukcija (EN 1996).
5. Eurocode 8 – Design of structures for earthquake resistance – Part 1; General rules, seismic actions and rules for buildings, European committee for standardization, Brussels 2004.
6. <http://seizkarta.gfz.hr/hazmap/karta.php>
7. Tomičić, I., Betonske konstrukcije, Društvo hrvatskih građevinskih konstruktora, Zagreb, 1996.

6. GRAĐEVINSKI NACRTI

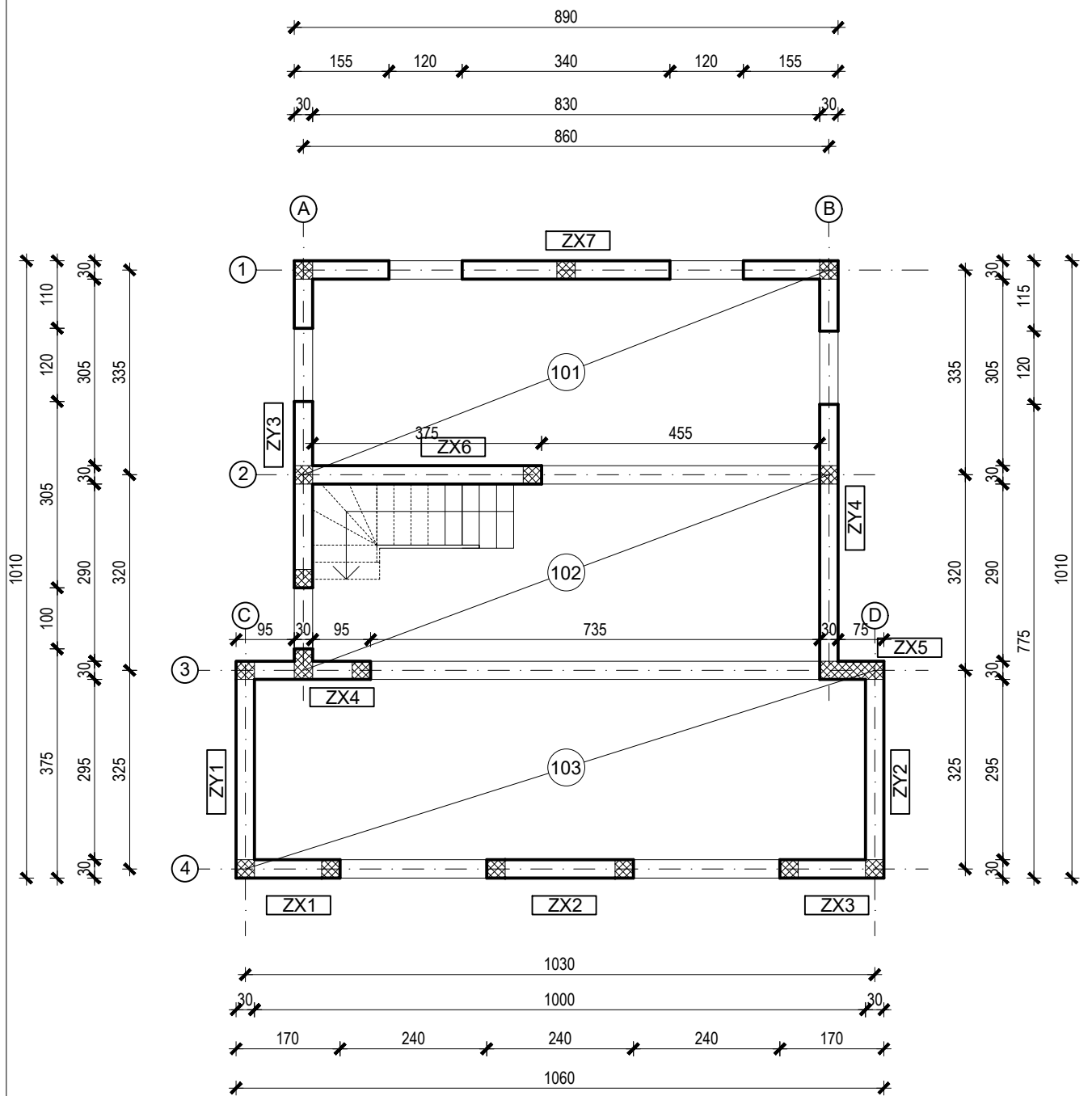

Fakultet građevinarstva, arhitekture i
geodezije
Sveučilišta u Splitu



Predmet:
Sadržaj:

Završni rad
PLAN POZICIJA 100

Mentor i
komentor:

Ivan Balić
Hrvoje Smoljanović

Student:

Petar Vrdoljak

Ak.god.:
2022./2023.

Mjerilo:
1:100

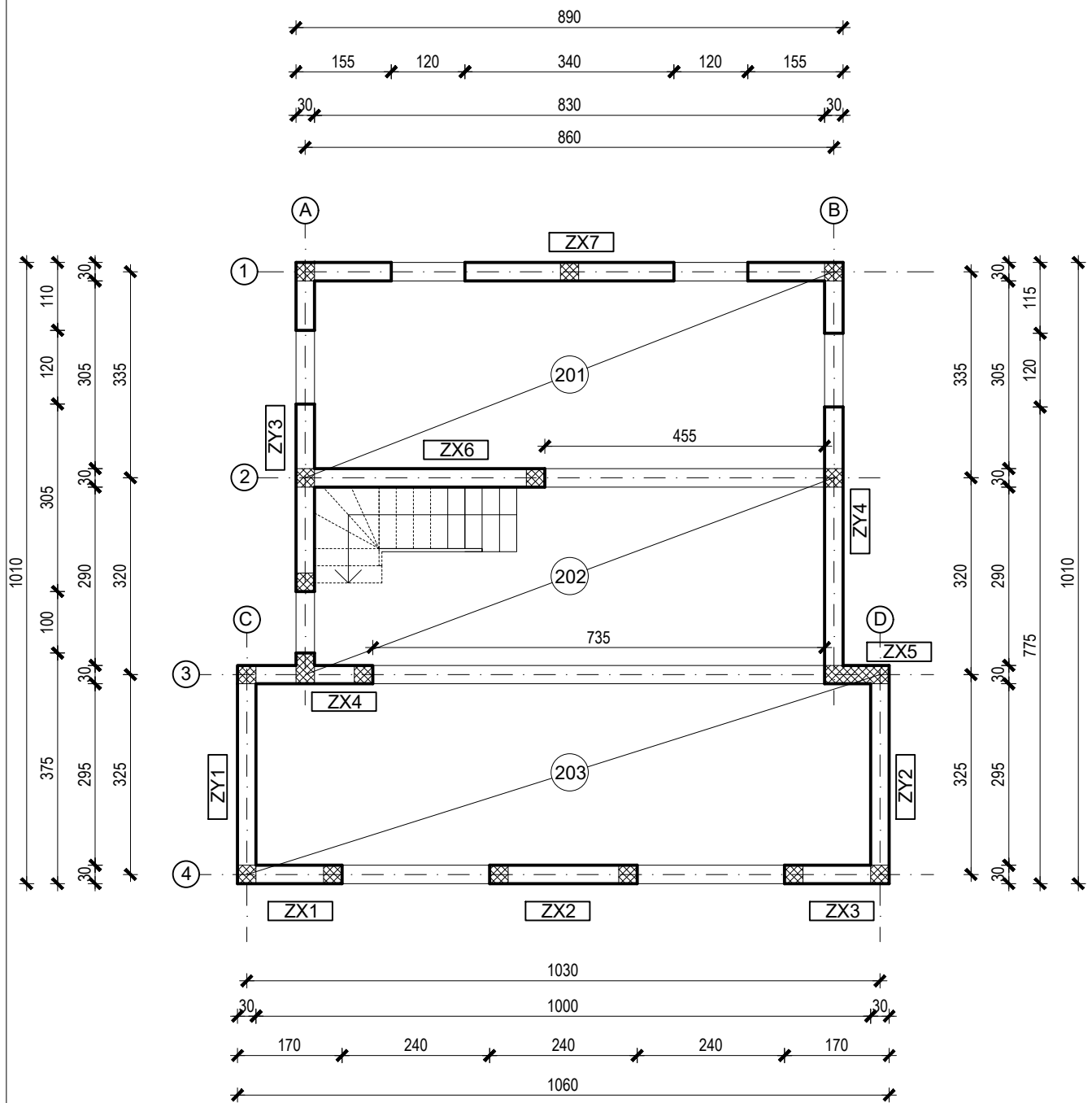

Fakultet građevinarstva, arhitekture i
geodezije
Sveučilišta u Splitu



Predmet:
Sadržaj:

Završni rad
PLAN POZICIJA 200

Mentor i
komentor:

Ivan Balić
Hrvoje Smoljanović

Student:

Petar Vrdoljak

Ak.god.:
2022./2023.

Mjerilo:
1:100

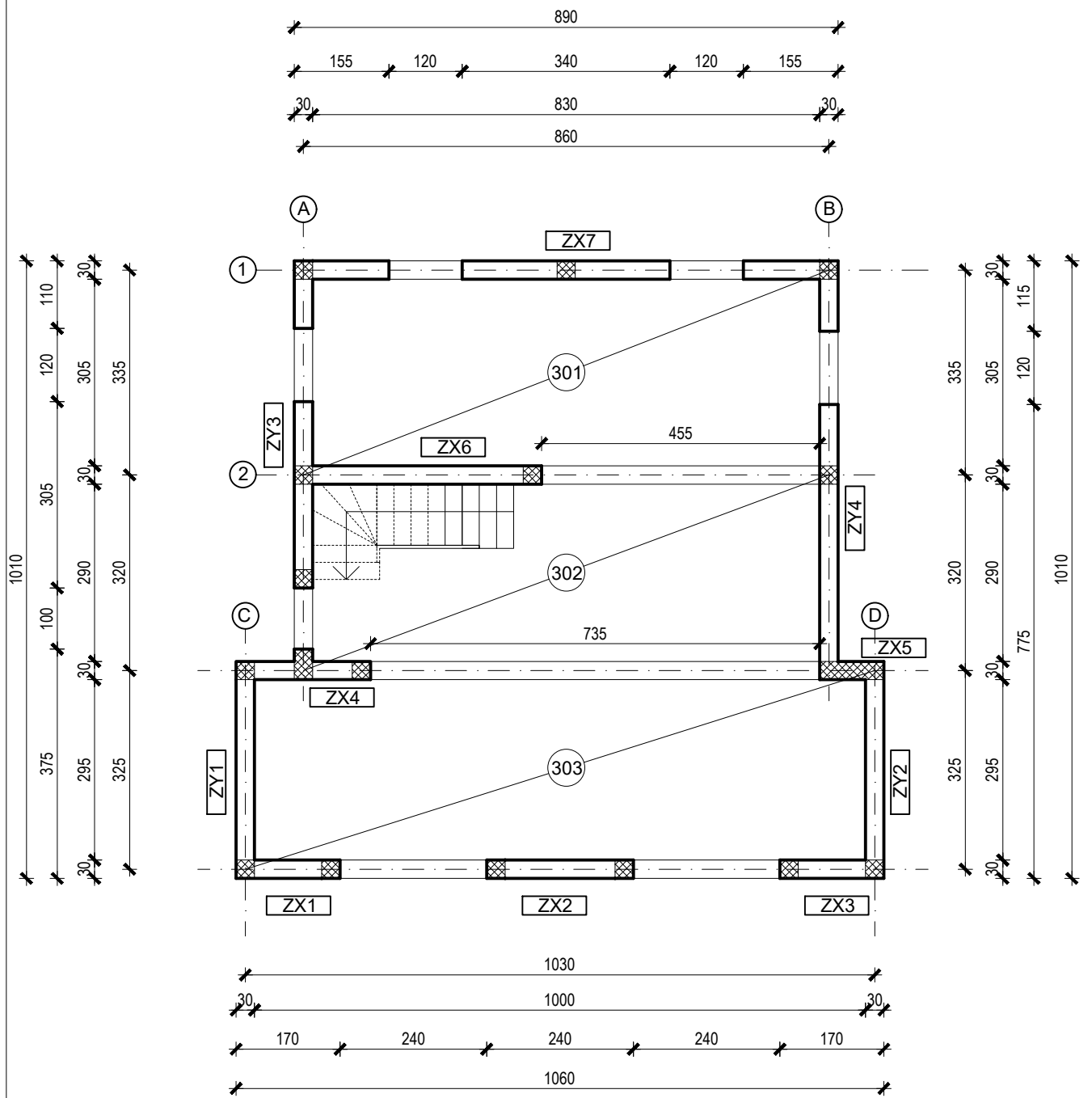

Fakultet građevinarstva, arhitekture i
geodezije
Sveučilišta u Splitu



Predmet:
Sadržaj:

Završni rad
PLAN POZICIJA 300

Mentor i
komentor:

Ivan Balić
Hrvoje Smoljanović

Student:

Petar Vrdoljak

Ak.god.:
2022./2023.

Mjerilo:
1:100

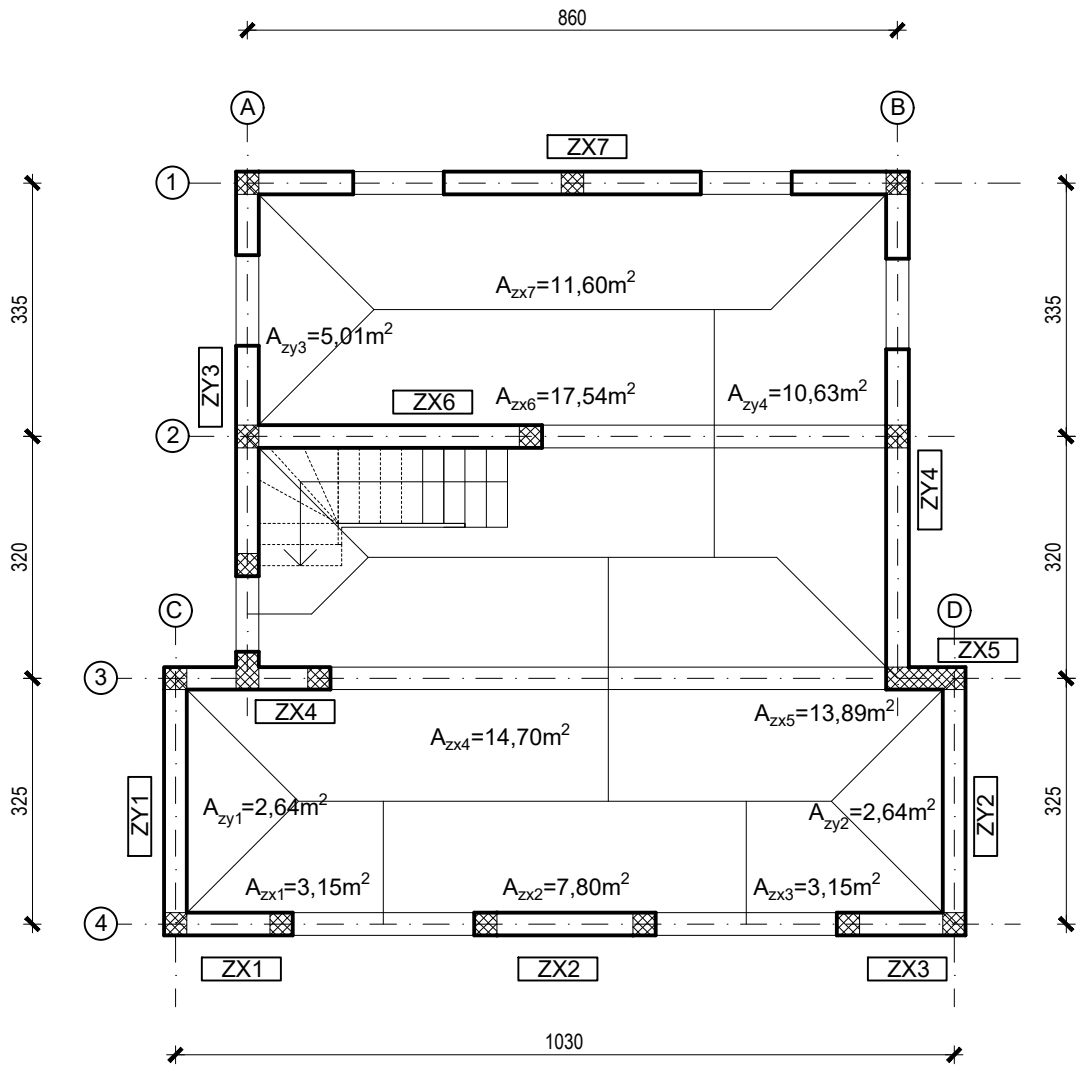

Fakultet građevinarstva, arhitekture i
geodezije
Sveučilišta u Splitu



Predmet: Završni rad
Sadržaj: UTJECAJNE POVRŠINE PLOČE POZICIJE 100

Mentor i
komentor: Ivan Balić
Hrvoje Smoljanović
Student: Petar Vrdoljak

Ak.god.: 2022./2023.

Mjerilo: 1:100

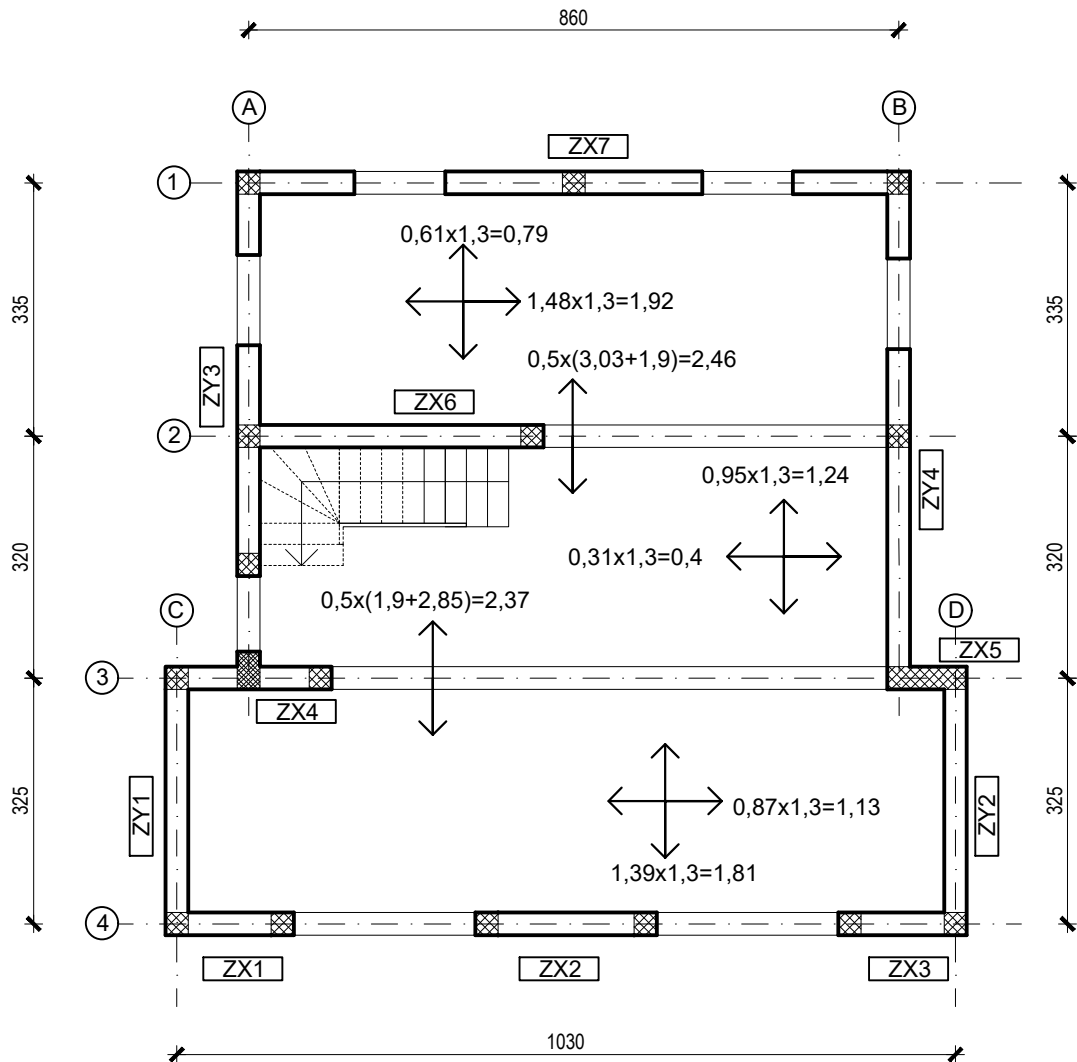

Fakultet građevinarstva, arhitekture i
geodezije
Sveučilišta u Splitu



Predmet: Završni rad

Sadržaj: RASPODJELA ARMATURE PLOČE
POZICIJE 100

Mentor i
komentor: Ivan Balić
Hrvoje Smoljanović

Student: Petar Vrdoljak

Ak.god.:
2022./2023.

Mjerilo:
1:100

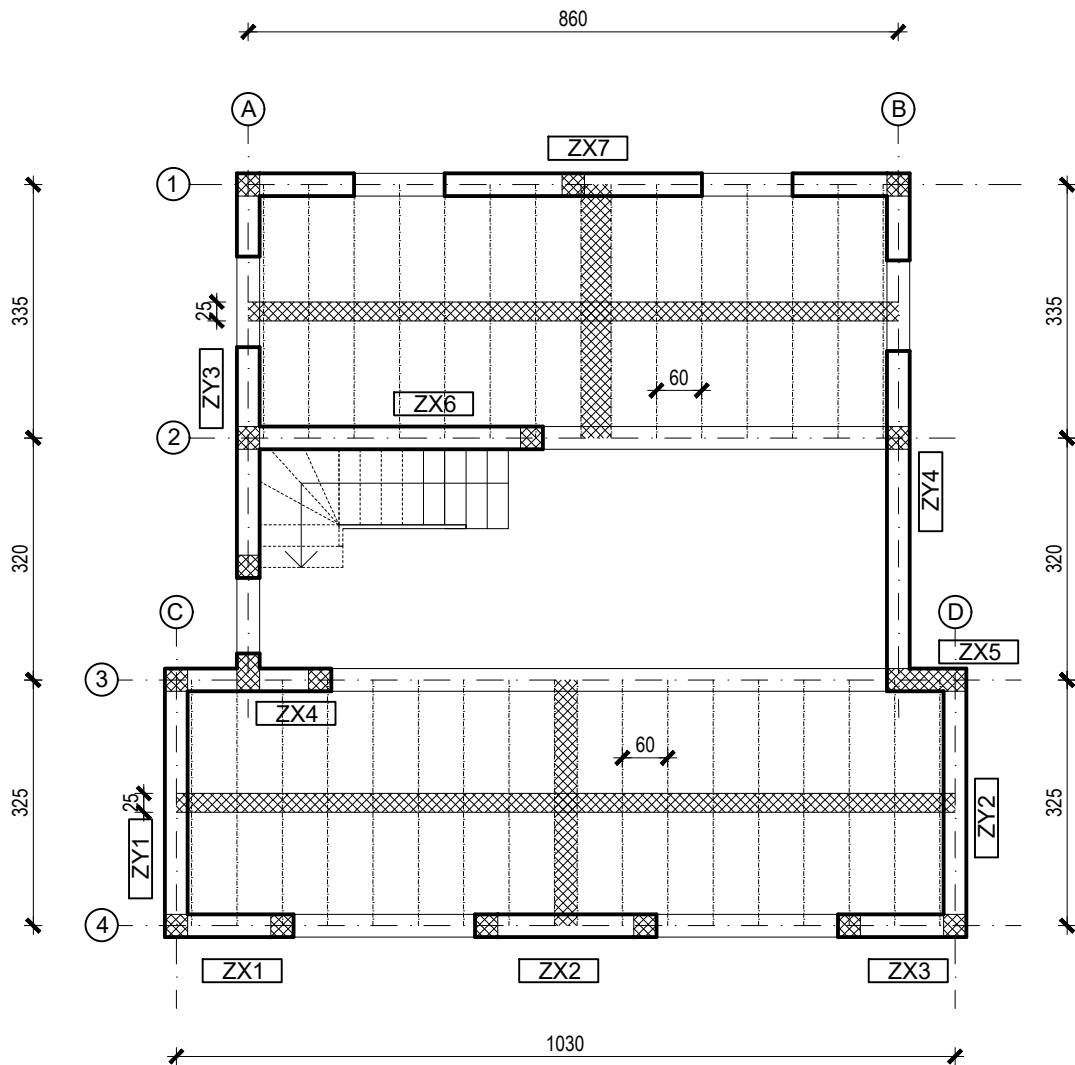

Fakultet građevinarstva, arhitekture i
geodezije
Sveučilišta u Splitu



Predmet: Završni rad
Sadržaj: PLAN POLAGANJA GREĐICA
NA POZICIJAMA 200 i 300

Mentor i
komentor: Ivan Balić
Hrvoje Smoljanović

Student: Petar Vrdoljak

Ak.god.:
2022./2023.

Mjerilo:
1:100

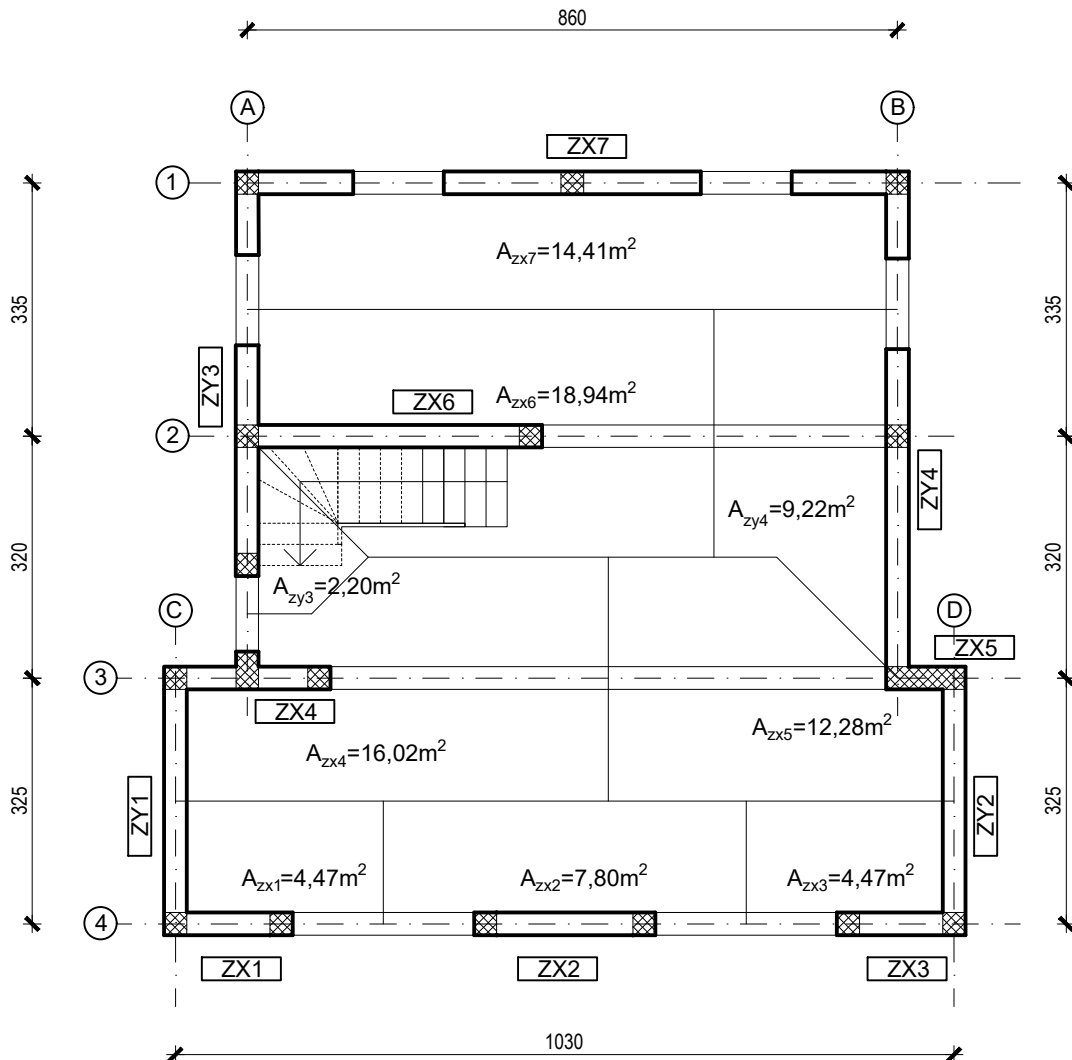

Fakultet građevinarstva, arhitekture i
geodezije
Sveučilišta u Splitu



Predmet: Završni rad
Sadržaj: UTJECAJNE POVRŠINE PLOČE
 POZICIJE 200 I 300
Mentor i komentor: Ivan Balić
 Hrvoje Smoljanović
Student: Petar Vrdoljak

Ak.god.:
2022./2023.
Mjerilo:
1:100

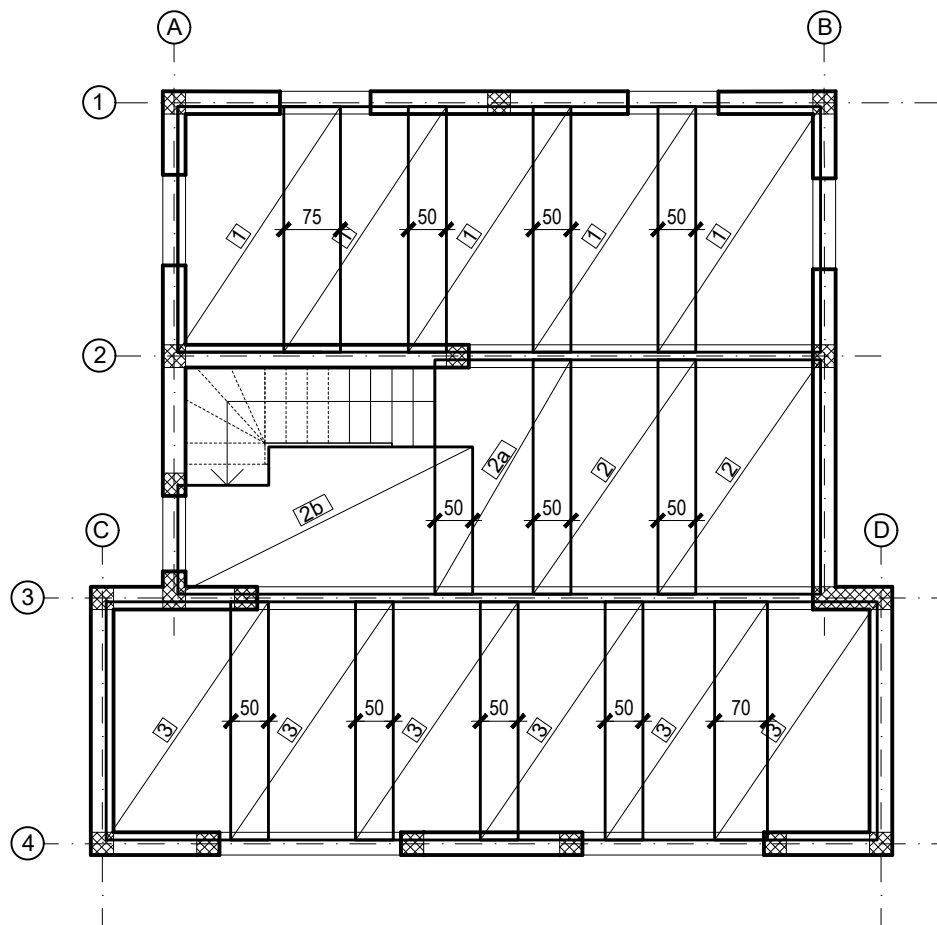

- | | | | |
|----|--------|------------|---------|
| 1 | Q-196; | 325x215 cm | - 5 kom |
| 2 | Q-196; | 310x215 cm | - 2 kom |
| 2a | Q-196; | 180x215 cm | - 1 kom |
| 2b | Q-196; | 390x195 cm | - 1 kom |
| 3 | Q-196; | 315x215 cm | - 6 kom |

Fakultet građevinarstva, arhitekture i
geodezije
Sveučilišta u Splitu



Predmet: Završni rad
Sadržaj: ARMATURA POZICIJE 100 (donja zona-mreže)

Mentor i
komentor: Ivan Balić
 Hrvoje Smoljanović

Student: Petar Vrdoljak

Ak.god.:
2022./2023.

Mjerilo:
1:100

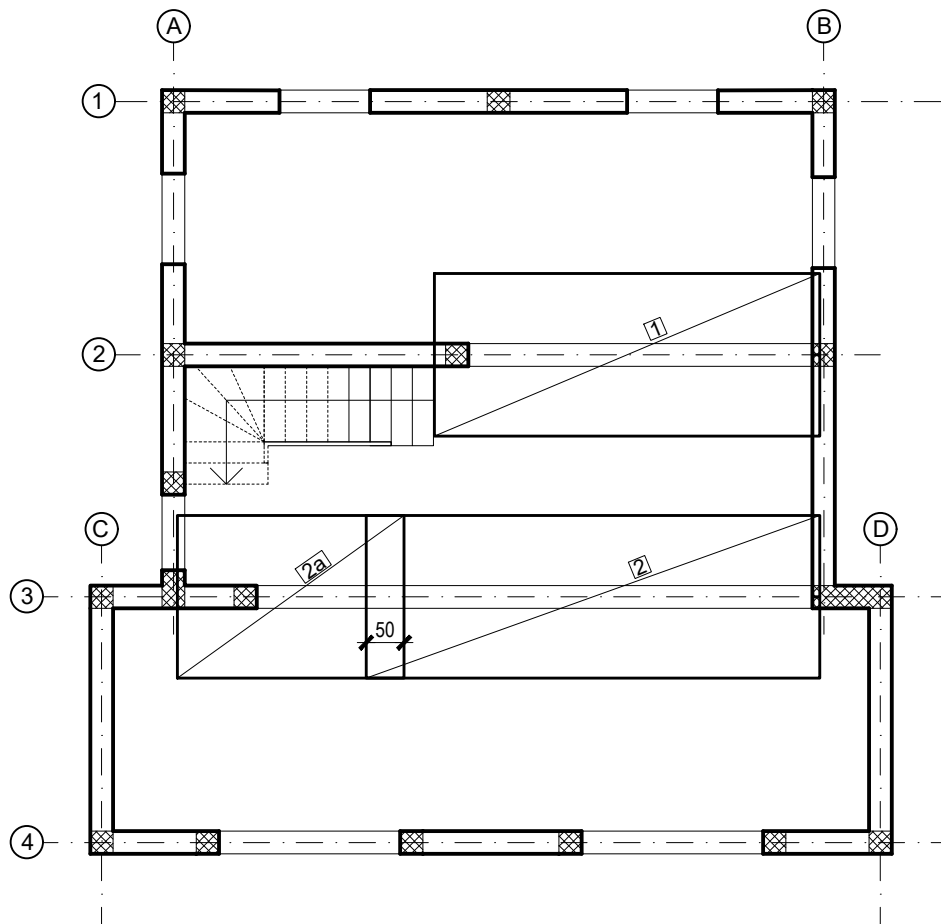

1	Q-283; 510x215 cm - 1 kom
2	Q-283; 600x215 cm - 1 kom
2a	Q-283; 300x215 cm - 1 kom

Fakultet građevinarstva, arhitekture i
geodezije
Sveučilišta u Splitu



Predmet: Završni rad
Sadržaj: ARMATURA POZICIJE 100 (gornja zona)

Mentor i
komentor: Ivan Balić
 Hrvoje Smoljanović

Student: Petar Vrdoljak

Ak.god.:
2022./2023.

Mjerilo:
1:100

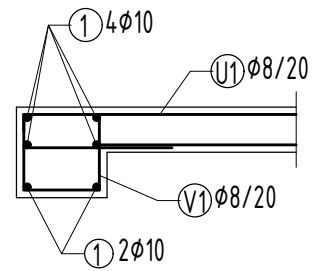
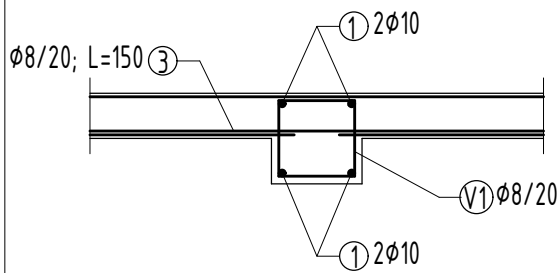
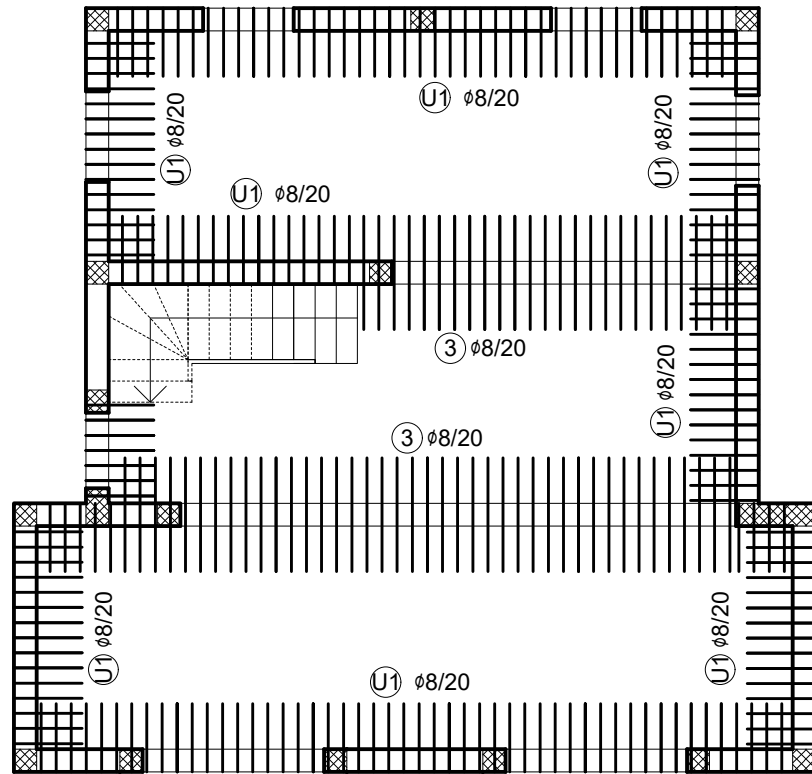

V1 $\phi 8$; L=120

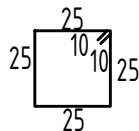

U1 $\phi 8$; L=150 (kom 196)

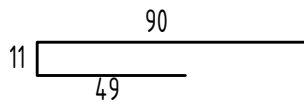

3 $\phi 8$; L=150

(kom 61)

150

Fakultet građevinarstva, arhitekture i
geodezije
Sveučilišta u Splitu



Predmet: Završni rad
Sadržaj: ARMATURA POZICIJE 100 (donja zona-šipke)

Mentor i
komentor: Ivan Balić
Hrvoje Smoljanović

Student: Petar Vrdoljak

Ak.god.:
2022./2023.

Mjerilo:
1:100

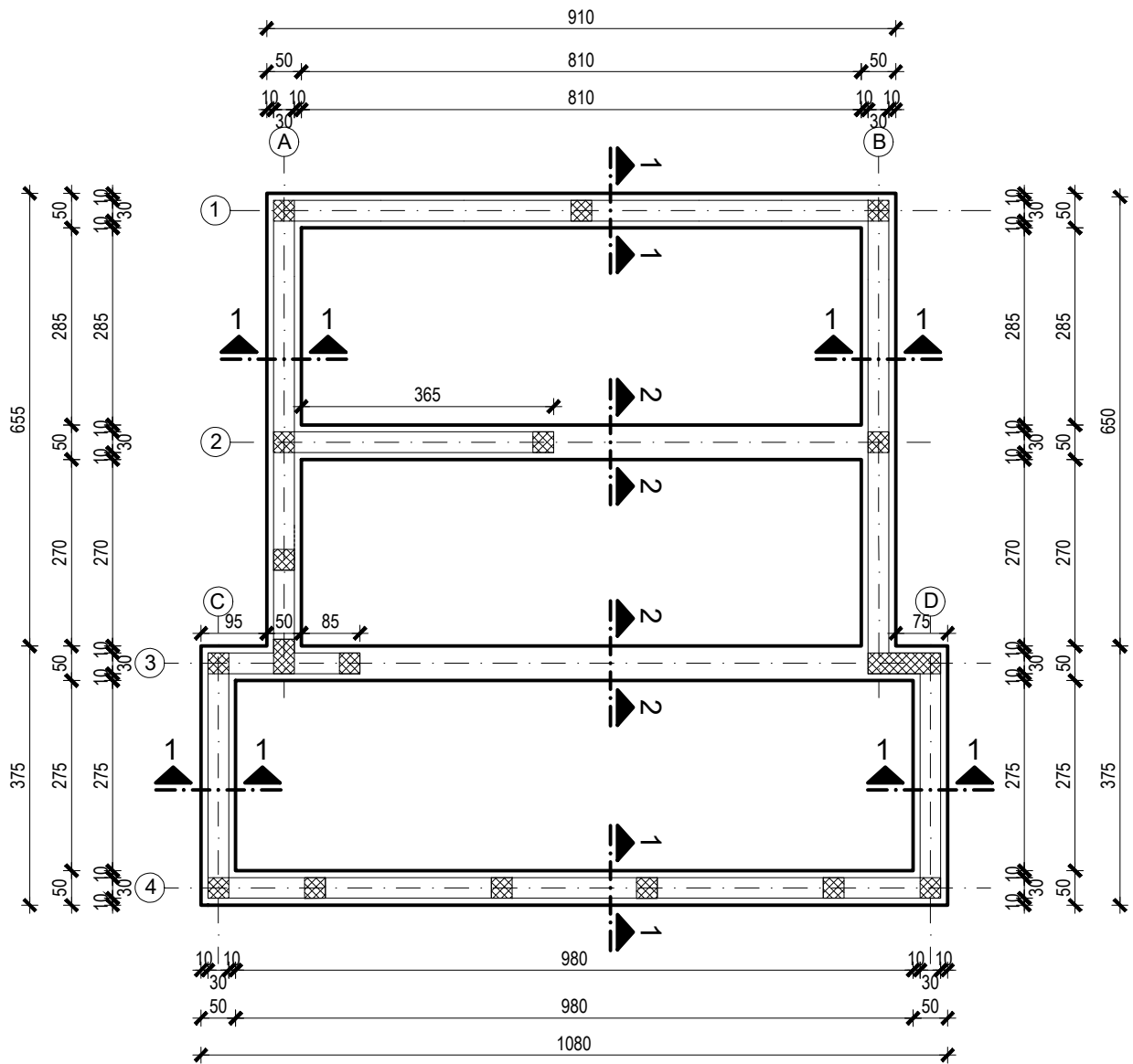

Presjek 1-1
M 1:50

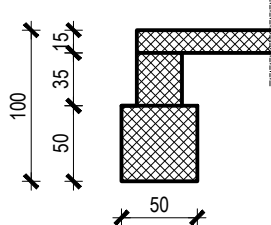

Presjek 2-2
M 1:50

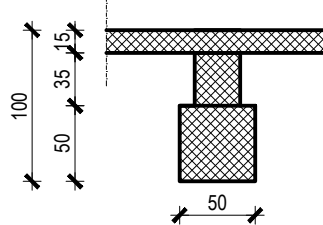

Fakultet građevinarstva, arhitekture i
geodezije
Sveučilišta u Splitu



Predmet:
Sadržaj:

Završni rad
TLOCRT TEMELJA

Mentor i
komentor:

Ivan Balić
Hrvoje Smoljanović

Student:

Petar Vrdoljak

Ak.god.:
2022./2023.

Mjerilo:
1:100

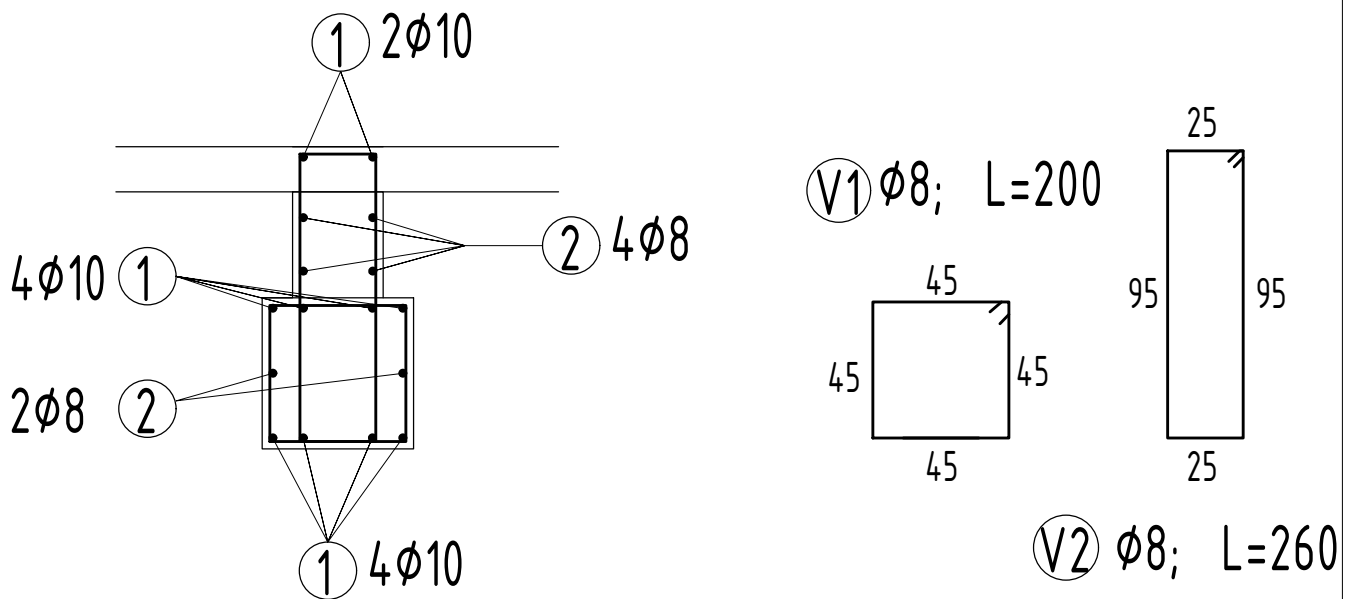
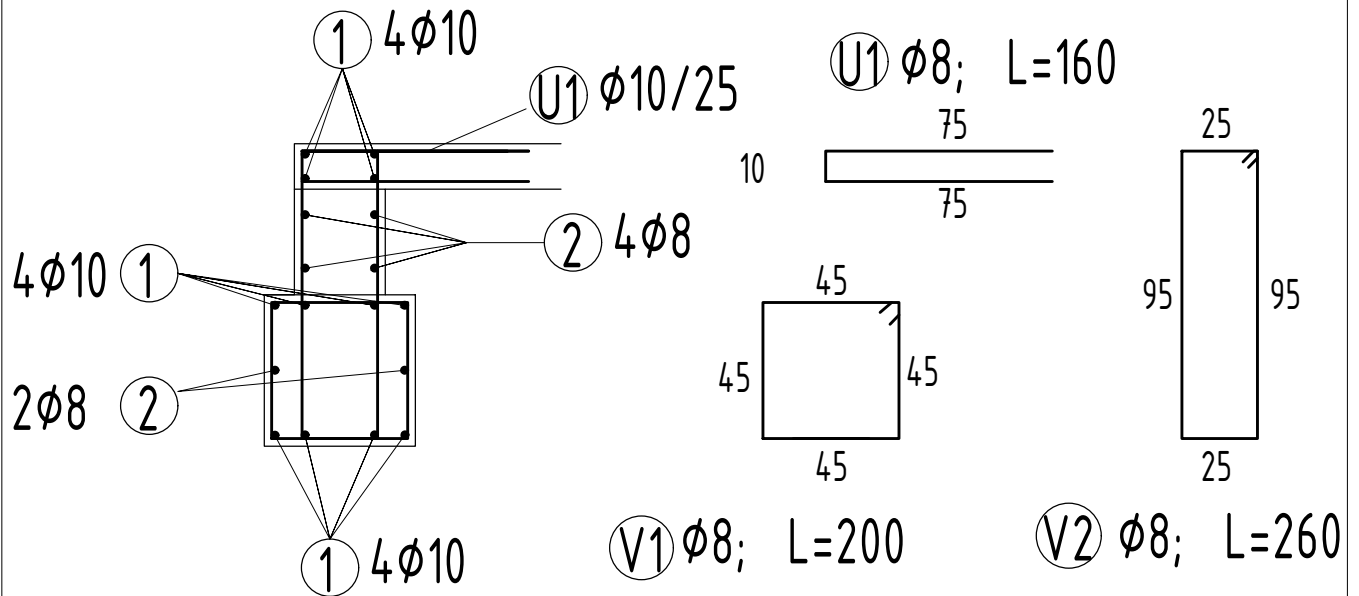

ANKERI NA MJESTU
VERTIKALNIH SERKLAŽA

A1) $\phi 12$; L=200cm

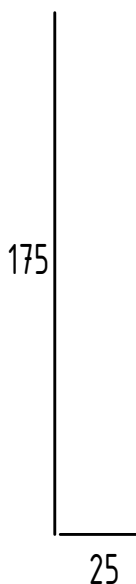

Fakultet građevinarstva, arhitekture i
geodezije
Sveučilišta u Splitu



Predmet: Završni rad
Sadržaj: ARMATURA TEMELJA

Mentor i
komentor: Ivan Balić
Hrvoje Smoljanović

Student: Petar Vrdoljak

Ak.god.:
2022./2023.

Mjerilo:
1:25

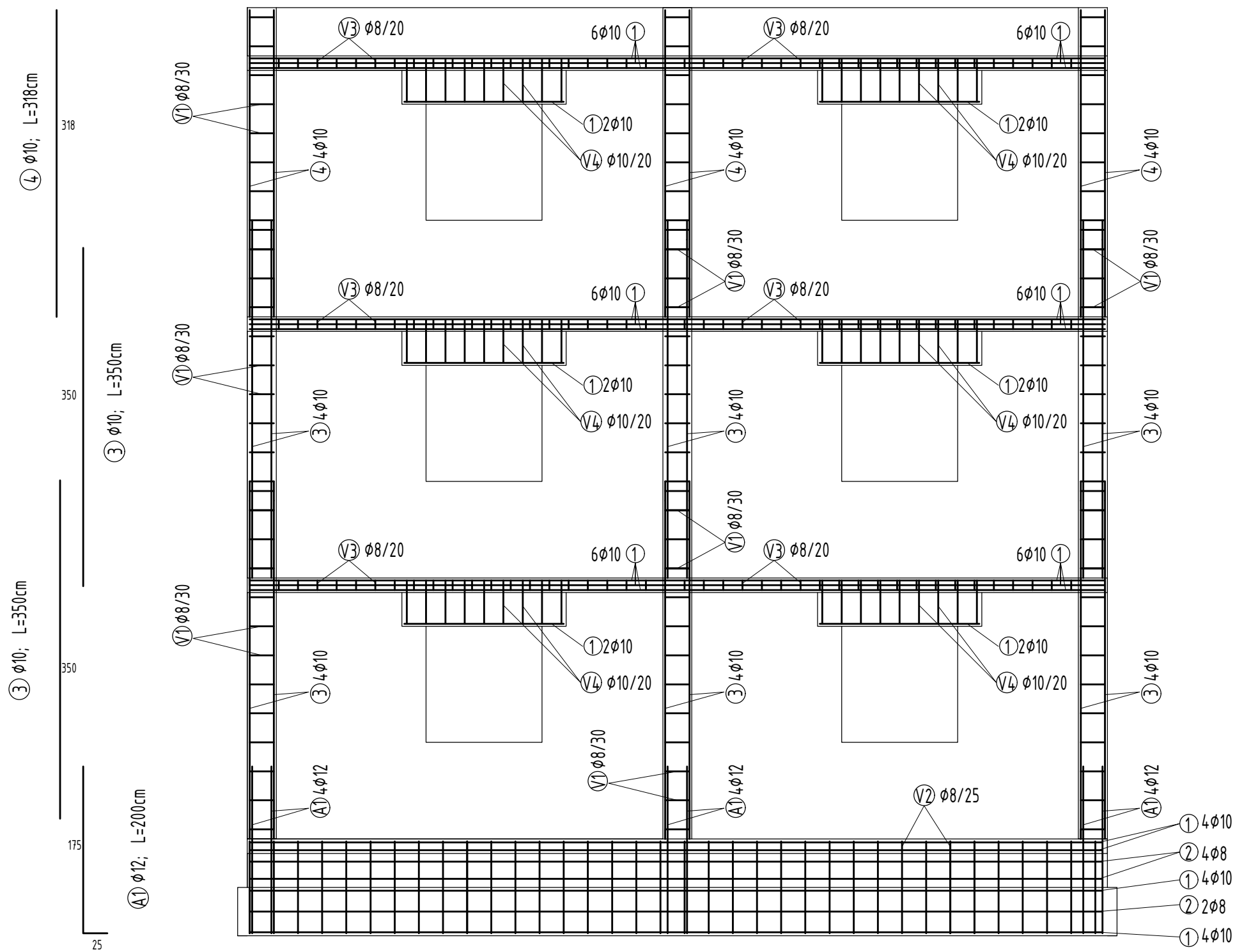

Fakultet građevinarstva, arhitekture i geodezije Sveučilišta u Splitu 	Predmet: Završni rad Sadržaj: ARMATURA ZIDA U OSI 1	Ak.god.: 2022./2023. Mjerilo: 1:50
	Mentor i komentor: Ivan Balić Hrvoje Smoljanović	
	Student: Petar Vrdoljak	