

# Proračun čelične konstrukcije proizvodne hale

---

**Kurt, Petar**

**Undergraduate thesis / Završni rad**

**2016**

*Degree Grantor / Ustanova koja je dodijelila akademski / stručni stupanj:*

**University of Split, Faculty of Civil Engineering, Architecture and Geodesy / Sveučilište u Splitu, Fakultet građevinarstva, arhitekture i geodezije**

*Permanent link / Trajna poveznica:* <https://um.nsk.hr/um:nbn:hr:123:544578>

*Rights / Prava:* [In copyright](#)/[Zaštićeno autorskim pravom.](#)

*Download date / Datum preuzimanja:* **2025-02-06**



*Repository / Repozitorij:*

[FCEAG Repository - Repository of the Faculty of Civil Engineering, Architecture and Geodesy, University of Split](#)



UNIVERSITY OF SPLIT



**SVEUČILIŠTE U SPLITU  
FAKULTET GRAĐEVINARSTVA, ARHITEKTURE I GEODEZIJE**

# **ZAVRŠNI RAD**

---

Petar Kurt

Split, 2016.

**SVEUČILIŠTE U SPLITU  
FAKULTET GRAĐEVINARSTVA, ARHITEKTURE I GEODEZIJE**

Petar Kurt

**Proračun čelične konstrukcije  
proizvodne hale**

Završni rad

Split, 2016.

**SVEUČILIŠTE U SPLITU**

**FAKULTET GRAĐEVINARSTVA, ARHITEKTURE I GEODEZIJE**

Split, Matice hrvatske 15

STUDIJ:                   **STRUČNI STUDIJ  
GRAĐEVINARSTVA**

KANDIDAT:               Petar Kurt

BROJ INDEKSA:       1489

KATEDRA:               **Katedra za metalne i drvene konstrukcije**  
PREDMET:               Metalne konstrukcije

**ZADATAK ZA ZAVRŠNI RAD**

Opis zadatka: Na temelju zadanih podataka čelične hale potrebno je dimenzionirati krovni rešetkasti sustav, stupove, temelje i sekundarnu konstrukciju.

Način izvedbe: montažno

Materijal konstrukcije: Fe-360

Objekt se nalazi na području Splita.

Razmak okvira: 5,7 (m)

U Splitu, 30.lipnja 2016.

Voditelj Završnog rada:

Dr.sc. Neno Torić

# 1. SADRŽAJ

1. SADRŽAJ.....	1
2. TEHNIČKI OPIS.....	2
3. ANALIZA OPTEREĆENJA.....	5
3.1. STALNO OPTEREĆENJE – KROVNA PLOHA.....	5
3.2. PROMJENJIVO OPTEREĆENJE - DJELOVANJE SNIJEGA.....	6
3.3. PROMJENJIVO OPTEREĆENJE - DJELOVANJE VJETRA.....	7
4. KOMBINACIJE OPTEREĆENJA ZA GRANIČNO STANJE NOSIVOSTI I GRANIČNO STANJE UPORABLJIVOSTI.....	14
5. GRANIČNO STANJE UPORABLJIVOSTI.....	15
5.1. VERTIKALNI PROGIB U SREDINI DONJEG POJASA REŠETKE.....	15
5.2. HORIZONTALNI POMAK VRHA STUPA.....	16
6. PRIKAZ REZULTATA PRORAČUNA GRANIČNOG STANJA NOSIVOSTI.....	17
6.1. SEKUNDARNA BOČNA KONSTRUKCIJA.....	17
6.2. SEKUNDARNA KROVNA KONSTRUKCIJA.....	17
6.3. KROVNI VJETROVNI SPREG.....	18
6.4. BOČNI VJETROVNI SPREG.....	18
6.5. MAKSIMALNE REZNE SILE U STUPU.....	19
6.6. MAKSIMALNE REZNE SILE U REŠETKI.....	21
7. DIMENZIONIRANJE.....	24
7.1. DIMENZIONIRANJE BOČNIH PODROŽNICA.....	24
7.2. DIMENZIONIRANJE KROVNIH PODROŽNICA.....	27
7.3. DIMENZIONIRANJE KROVNOG SPREGA.....	30
7.4. DIMENZIONIRANJE BOČNOG SPREGA.....	32
7.5. DIMENZIONIRANJE GORNJEG POJASA REŠETKE.....	34
7.6. DIMENZIONIRANJE DONJEG POJASA REŠETKE.....	37
7.7. DIMENZIONIRANJE ISPUNE REŠETKE.....	40
7.8. DIMENZIONIRANJE STUPA.....	43
8. PRORAČUN SPOJEVA.....	48
8.1. DIMENZIONIRANJE MONTAŽNOG NASTAVKA REŠETKE.....	48
8.2. DIMENZIONIRANJE SPOJA STUP-REŠETKA.....	50
8.3. DIMENZIONIRANJE UPETOG SPOJA STUP - TEMELJ.....	52
9. DIMENZIONIRANJE TEMELJA.....	56
10. GRAFIČKI PRILOZI.....	58
10.1. GENERALNI PLAN POZICIJA M 1:200.....	58
10.2. PRESJEK KROZ GLAVNI OKVIR M 1:50.....	58
10.3. DETALJI SPOJEVA M 1:10.....	58
10.4. ISKAZ KOLIČINE ČELIKA.....	58

## 2. TEHNIČKI OPIS

### Općenito:

Predmetna građevina nalazi se na području grada Splita. Tlocrtne dimenzije su 16,8 x 39,9 (m), visina iznosi 7,92 (m). Krovna ploha je u odnosu na horizontalnu ravninu nagnuta pod kutom  $\alpha = 4^\circ$ , što je ekvivalentno padu od 7 %. Projektirana je za potrebe skladištenja.

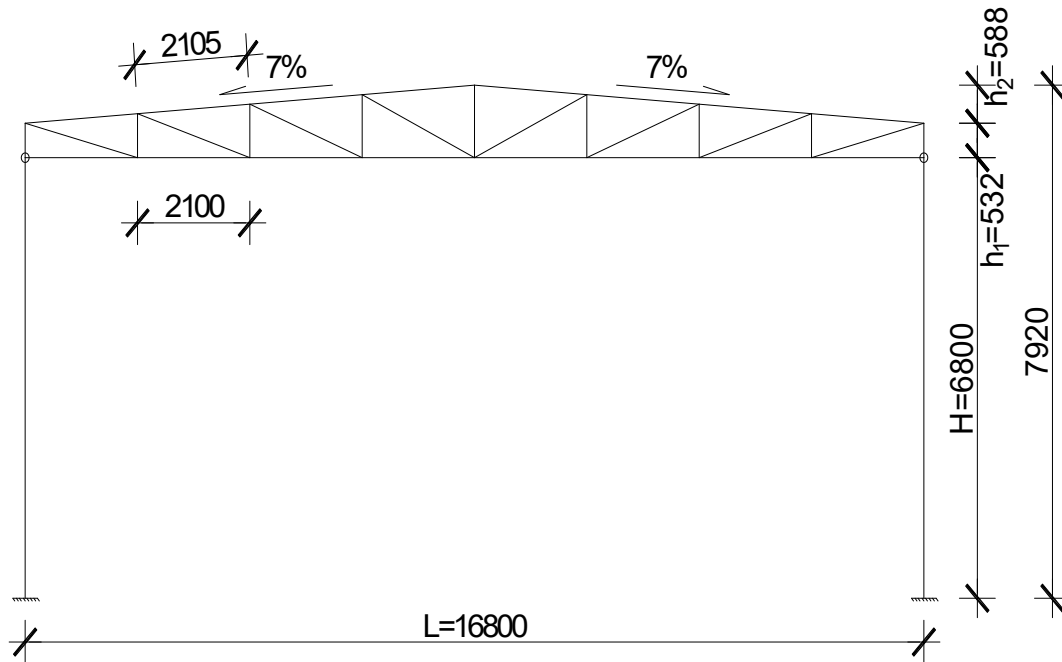

Slika 1. Geometrija glavnog nosača

Glavni nosivi sustav hale izveden je kao sustav 7 ravninskih okvira raspona 16,80 (m), stabilnih u svojoj ravnini, na međusobnom osnom razmaku od 5,70 (m).

Na gornje pojaseve se oslanjaju sekundarni krovni nosači (podrožnice), a na stupove su oslonjeni sekundarni bočni nosači na međusobnom osnom razmaku od 2,30 (m).

Stabilizacija hale u smjeru okomitom na glavni nosivi sustav ostvarena je spregovima u krovnim (horizontalnim) i bočnim (zidnim) ravninama i to u krajnjim poljima (prvom i posljednjem).

Kao pokrov koriste se aluminijski sendvič paneli.

## **Konstruktivni elementi**

### **Rešetka**

Proračunom je odabrani donji pojas profila CFRHS100x100x5 (mm) i gornji pojas profila CFRHS150x100x4 (mm), te vertikale i dijagonale CFRHS70x70x4 (mm). Zbog maksimalne proizvodne dužine od 12,0 (m), donji pojas se sastoji iz 2 dijela, jednog dužine 12 000 (mm) i drugi 4800 (mm).

### **Stupovi**

Proračunom su odabrani stupovi širokopojasnih H profila HEB 320 , svaki dužine 6690 (mm).

### **Krovne podrožnice**

Odabrane su krovne podrožnice profila IPE180.

### **Bočne podrožnice**

Odabrani sekundarni bočni nosači su profila IPE180.

### **Spregovi**

Kao dijagonale krovnog sprega odabrane su čelične šipke (sajle)  $\Phi 20$  mm.

Kao dijagonale bočnog sprega odabrane su čelične šipke (sajle)  $\Phi 22$  mm.

## **Spojevi**

### **Vlačni nastavak rešetke**

Spoj se izvodi čeonim pločama dimenzija 215x215x20(mm) za donji pojas i 215x265x20(mm) za gornji pojas, navarenim na krajeve greda međusobno pričvršćenim vijcima M22 k.v. 10.9 nosivim na vlak i odrez.

### **Stup – rešetka**

Spoj donje pojasnice rešetke sa stupom dimenzioniran je na vlačnu silu, ostvaruje se čeonim pločama dimenzija 300/320/12 (mm) i vijcima M16 k.v. 10.9 nosivim na vlak i odrez.

### **Stup – temelj**

Spoj se izvodi podložnom pločom dimenzija 550/350/20 (mm) navarenom na kraj stupa i pričvršćenom vijcima M22 k.v 10.9 nosivim na vlak i odrez, te sidrenim u armirano–betonski temelj. Između podložne ploče i armirano–betonskog temelja podlijeva se ekspandirajući mort.

### **O proračunu konstrukcije**

Statičkom analizom obuhvaćena su opterećenja koja djeluju na konstrukciju i to:

- stalno (vlastita težina okvira, sekundarna konstrukcija, instalacije),
- snijeg,
- vjetar

Analiza je provedena na jednom reprezentativnom ravninskom okviru na kojeg otpada 5,7 (m) širine krovne plohe.

Odgovarajući koeficijenti za vjetar i snijeg uzeti su iz propisanih tablica. Kao mjerodavna za dimenzioniranje konstruktivnih elemenata i spojeva uzeta je najnepovoljnija kombinacija opterećenja.

Proračun konstrukcije izvršen je programskim paketom „SCIA 16“

### **Materijal za izradu konstrukcije**

Svi elementi konstrukcije (glavni nosivi okvir, sekundarne konstrukcije, spregovi i spojne ploče) izrađeni su od građevinskog čelika Fe-360 (S 235).

### **Antikorozijska zaštita**

Svi dijelovi čelične konstrukcije moraju biti zaštićeni od korozije.

Kao vrsta zaštite od korozije koristi se zaštita vrućim pocinčavanjem i zaštitnim premazom.

### **Zaštita od požara**

Svi elementi moraju se zaštititi posebnim premazima otpornim na visoke temperature, s ciljem što veće zaštite od požara. Također je potrebno opremiti objekt za slučaj nastanka požara uređajima za najavu požara kao i opremom za njegovo gašenje.

### **Montaža i transport**

Pozicije okvira će se izrezati u radionici te transportirati na gradilište. Pri tome je potrebno obratiti posebnu pažnju na montažu i transport da bi se izbjegla nepotrebna oštećenja. Izvođač je dužan izraditi plan montaže nosača kojeg treba zajedno sa transportnim planom dostaviti nadzornoj službi na suglasnost. Potrebno je poduzeti sve mjere u skladu s „Pravilnikom o zaštiti na radu“.



### 3. ANALIZA OPTEREĆENJA

#### 3.1. Stalno opterećenje – krovna ploha

-sendvič paneli:  $g=0,25 \text{ kN/m}^2$

-sekundarna konstrukcija i spregovi:  $g=0,20 \text{ kN/m}^2$

-instalacije:  $g=0,10 \text{ kN/m}^2$

Ukupno:  $q = 0,55 \text{ kN/m}^2$

$$a = \frac{2,10}{\cos \alpha} = \frac{2,10}{\cos 4} = 2,105 \text{ m}$$

$$G = g \cdot a \cdot l = 0,55 \cdot 2,105 \cdot 5,7 = 6,60 \text{ kN}$$

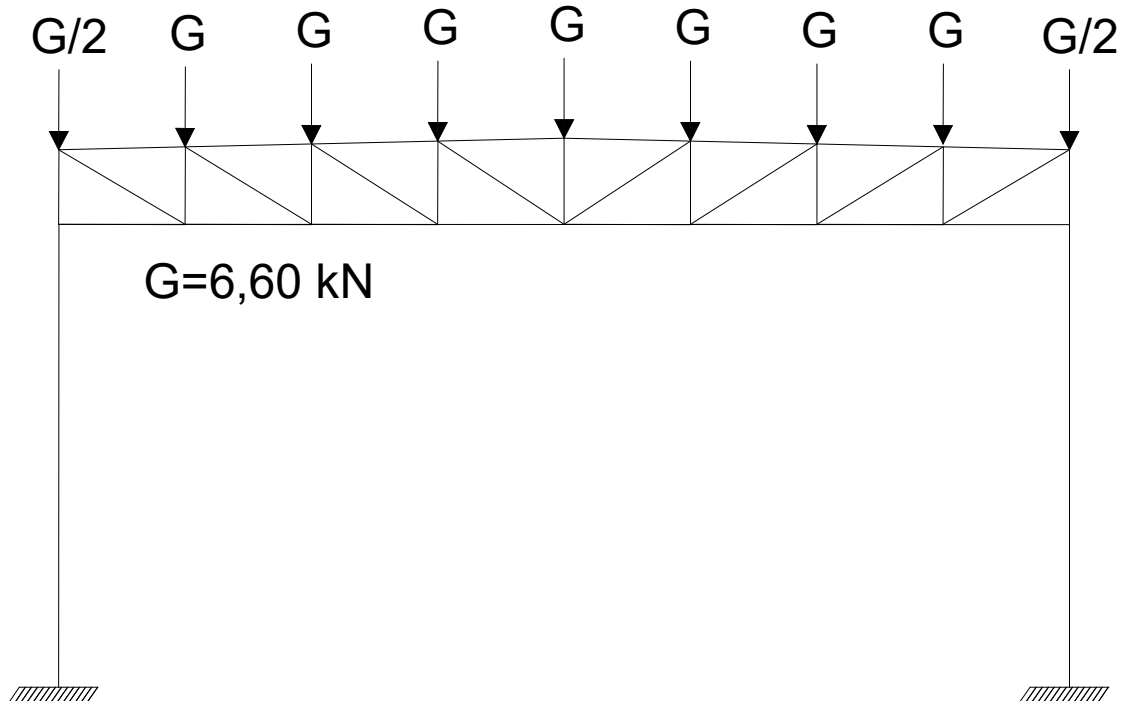

Slika 2. Stalno opterećenje u čvorovima okvira

### 3.2. Promjenjivo opterećenje - djelovanje snijega

$$s = \mu_i \cdot C_e \cdot C_t \cdot s_k \text{ (kN / m}^2\text{)}$$

$$C_e = C_t = 1,0$$

$S_k = 0,50 \text{ kN/m}^2$  - očitano za područje C - Split

$$\mu_i = 0,8 \text{ za kut } 4^\circ$$

$$s = 0,8 \cdot 1,0 \cdot 1,0 \cdot 0,5 = 0,40 \frac{\text{kN}}{\text{m}^2}$$

$$S = s \cdot a \cdot l = 0,40 \cdot 2,105 \cdot 5,7 = 4,80 \text{ kN}$$

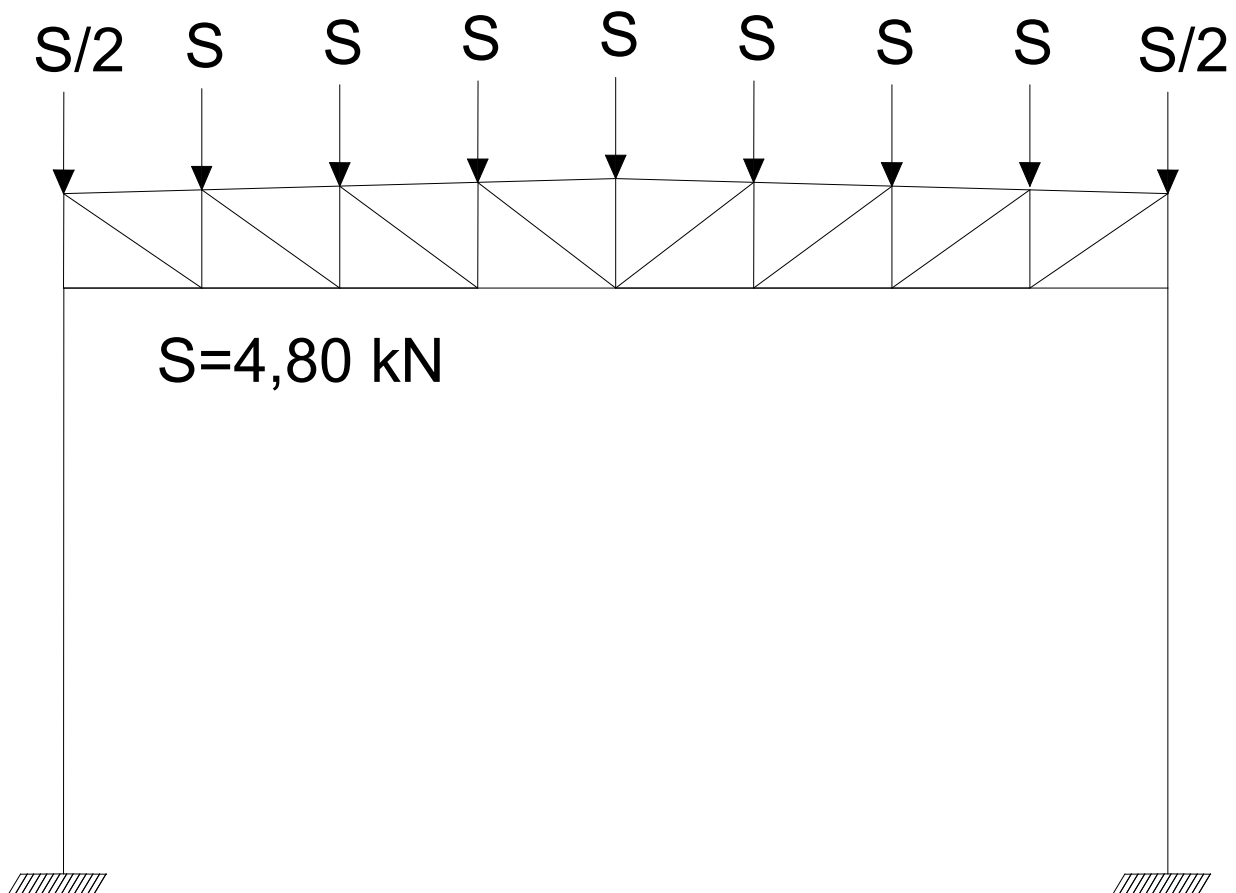

Slika 3. Opterećenje snijegom u čvorovima okvira

### 3.3. Promjenjivo opterećenje - djelovanje vjetra

vanjski pritisak  $\rightarrow w_e = q_b(z_e) \cdot c_{pe}$

unutarnji pritisak  $\rightarrow w_i = q_p(z_i) \cdot c_{pi}$

$q_p(z_e(i))$   $\rightarrow$  pritisak brzine vjetra pri udaru  
 $z_e$  i  $z_i$   $\rightarrow$  referentne visine za vanjski ili unutarnji pritisak  
 $c_{pe}$  i  $c_{pi}$   $\rightarrow$  vanjski i unutarnji koeficijenti pritiska

#### Osnovni pritisak vjetra

$$q_b = \frac{\rho}{2} \cdot v_b^2$$

$\rho$   $\rightarrow$  gustoća zraka  $\rho = 1,25 \text{ kg/m}^3$

$v_b$   $\rightarrow$  osnovna brzina dana je izrazom:

$$v_b = c_{dir} \cdot c_{season} \cdot v_{b,0}$$

$v_{b,0} = 35 \text{ m/s}$ , za područje III (Split)

$c_{dir}$   $\rightarrow$  koeficijent smjera vjetra;

$$c_{dir} = 1.0$$

$c_{season}$   $\rightarrow$  koeficijent doba godine;

$$c_{season} = 1.0$$

$$v_b = c_{dir} \cdot c_{season} \cdot v_{b,0} = 1 \cdot 1 \cdot 35 = 35 \text{ m/s}$$

$$q_b = \frac{\rho}{2} \cdot v_b^2$$

$$q_b = \frac{1,25}{2} \cdot 35^2$$

$$q_b = 765.63 \text{ N/m}^2$$

$$q_b = 0,765 \text{ kN/m}^2$$

#### Pritisak brzine vjetra pri udaru:

$$q_p(z) = c_e(z) \cdot q_b$$

Očitano za kategoriju zemljišta III, i visinu objekta 7,9 m  $c_e(z_e) = 1,7$

$$q_p(z) = c_e(z) \cdot q_b = 1.7 \cdot 0.765 = 1.30 \text{ kN/m}^2$$

Koef. unutarnjeg tlaka

Koeficijenti  $c_{pi}$  ovise o veličini i raspodjeli otvora na oblozi hale (fasada i krov). U ovom primjeru nije definiran raspored i veličina otvora, zato se za vrijednost  $c_{pi}$  usvajaju vrijednosti za pozitivni unutarnji pritisak i za negativni unutarnji pritisak:

Unutarnji tlak:  $C_{pi} = +0,2$

Unutarnji podtlak:  $C_{pi} = -0,3$

Koef. vanjskog tlaka

Koeficijenti vanjskog pritiska se određuju na način da se krovna ploha podijeli na zone kako je to prikazano na slici.

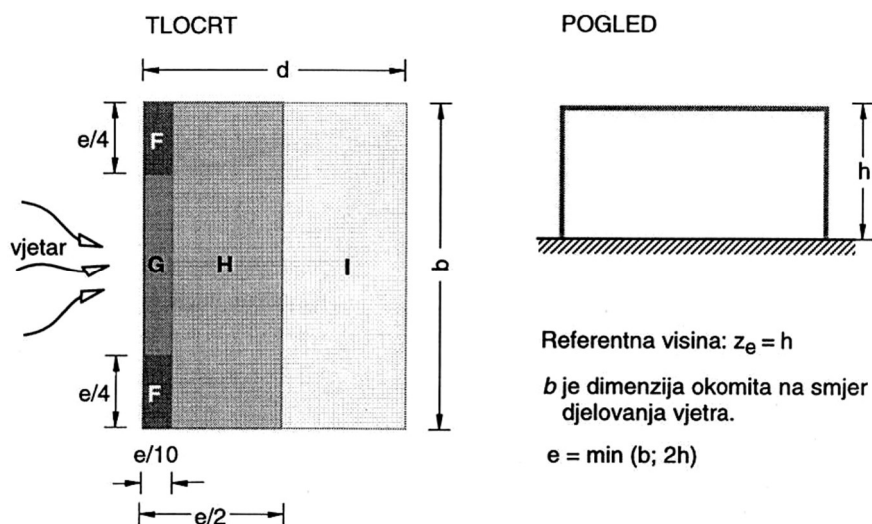

Slika 4. Raspodjela krovne plohe na vjetrovne zone

$h$	→ visina u sljemenu dvostrešnog krova	$h = 7,92$ m
$d$	→ dubina građevine	$d = 16,8$ m
$b$	→ širina građevine (površina izložena vjetru)	$b = 39,9$ m (7x5,7)

SMJER VJETRA  $\Theta = 0^0$

$$e = \min \{b; 2h\} = \min \{5,7 \cdot 7 = 39,9 ; 2 \cdot 7,92 = 15,84\} = 15,84 \text{ m}$$

$$e/4 = 3,96 \text{ m}$$

$$e/10 = 1,58 \text{ m}$$

za nagib  $5^0$

PODRUČJE	F	G	H	I=J	D	E
$C_{pe,10}$	-1,8	-1,2	-0,7	$\pm 0,2$	+0,7	-0,3

Pritisak vjetra na unutrašnje površine:

$$W_i = q_p(z_i) \cdot c_{pi} = 1.30 \cdot c_{pi}$$

Pritisak vjetra na vanjske površine:

$$W_e = q_p(z_e) \cdot c_{pe} = 1.30 \cdot c_{pe}$$

Rezultirajuće djelovanje vjetra:

$$w_k = w_e - w_i \quad [\text{kN/m}^2]$$

Vjetar **W1**     **pozitivni** unutarnji pritisak ( $c_{pi} = +0,2$ )

$$W_k = w_k \cdot L \quad [\text{kN/m}'] \quad L = 5,7 \text{ m} \quad \rightarrow \quad \text{razmak okvira}$$

PODRUČJE	F	G	H	I=J	D	E
$w_e$ (kN/m <sup>2</sup> )	-2,34	-1,56	-0,91	-0,26	+0,91	-0,39
$w_i$ (kN/m <sup>2</sup> )	+0,26	+0,26	+0,26	+0,26	+0,26	+0,26
$w_k$ (kN/m <sup>2</sup> )	-2,60	-1,82	-1,17	-0,52	+0,65	-0,65
$W_k$ (kN/m')	-14,82	-11,80	-6,67	-2,96	+3,71	-3,71

Vjetar **W2**     **negativni** unutarnji pritisak ( $c_{pi} = -0,3$ )

$$W_k = w_k \cdot L \quad [\text{kN/m}'], \quad L = 5,7 \text{ m}, \quad \rightarrow \quad \text{razmak okvira}$$

PODRUČJE	F	G	H	I=J	D	E
$w_e$ (kN/m <sup>2</sup> )	-2,34	-1,56	-0,91	-0,26	+0,91	-0,39
$w_i$ (kN/m <sup>2</sup> )	-0,39	-0,39	-0,39	-0,39	-0,39	-0,39
$w_k$ (kN/m <sup>2</sup> )	-1,95	-1,17	-0,52	-0,13	+1,30	-0,00
$W_k$ (kN/m')	-11,12	-6,67	-2,96	-0,74	+7,41	-0,00

Za proračun se uzima srednji glavni nosač!

Vjetar W1

$$W_1 = W_{GK} \cdot a / 2 = -11,80 \cdot 2,10 / 2 = -12,63 \text{ kN}$$

$$W_2 = (W_{GK} + W_{HK}) \cdot a / 2 = (-11,80 - 6,67) \cdot 2,10 / 2 = -19,76 \text{ kN}$$

$$W_3 = W_{HK} \cdot a = -6,67 \cdot 2,10 = -14,27 \text{ kN}$$

$$W_4 = W_{HK} \cdot a / 2 = -6,67 \cdot 2,10 / 2 = -7,14 \text{ kN}$$

$$W_5 = W_{IK} \cdot a = -2,96 \cdot 2,10 = -6,33 \text{ kN}$$

$$W_6 = W_{IK} \cdot a / 2 = -2,96 \cdot 2,10 / 2 = -3,16 \text{ kN}$$

$$W_7 = W_{DK} \cdot h_1 / 2 = 3,71 \cdot 0,53 / 2 = 0,98 \text{ kN}$$

$$W_8 = W_{EK} \cdot h_1 / 2 = -3,71 \cdot 0,53 / 2 = -0,98 \text{ kN}$$

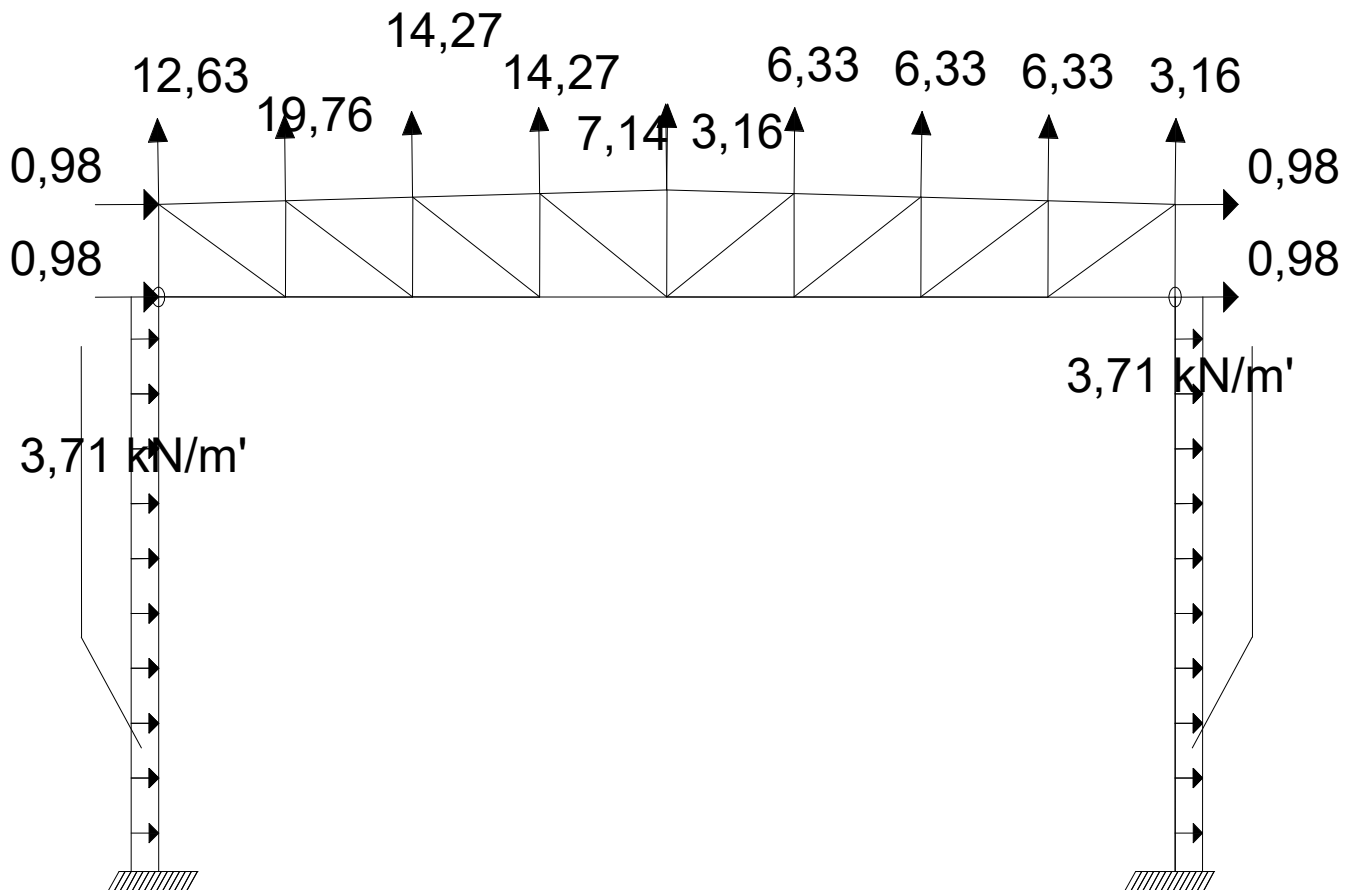

Slika 5. Djelovanje vjetra W1 na okvir

Vjetar W2

$$W_1 = W_{GK} \cdot a / 2 = -6,67 \cdot 2,10 / 2 = -7,17 \text{ kN}$$

$$W_2 = (W_{GK} + W_{HK}) \cdot a / 2 = (-6,67 - 2,96) \cdot 2,10 / 2 = -10,30 \text{ kN}$$

$$W_3 = W_{HK} \cdot a = -2,96 \cdot 2,10 = -6,33 \text{ kN}$$

$$W_4 = W_{HK} \cdot a / 2 = -2,96 \cdot 2,10 / 2 = -3,16 \text{ kN}$$

$$W_5 = W_{DK} \cdot h_1 / 2 = 7,41 \cdot 0,53 / 2 = 1,96 \text{ kN}$$

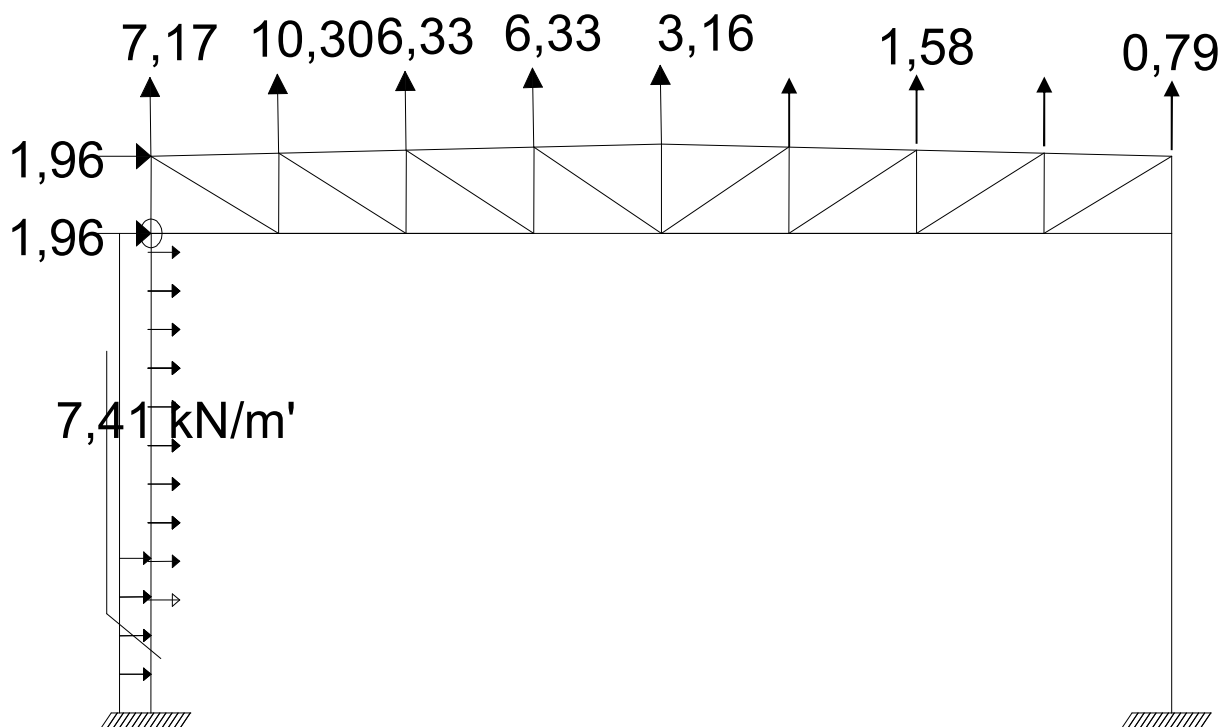

Slika 6. Djelovanje vjetra W2 na okvir

KROVNE PODROŽNICE:

Stalno opterećenje:  $G = g \cdot 2,105 = 0,35 \cdot 2,105 = 0,74 \text{ kN/m}$

Opterećenje snijegom:  $S = s \cdot 2,105 = 0,50 \cdot 2,105 = 1,05 \text{ kN/m}$

Opterećenje vjetrom (W1):  $W_H = w \cdot 2,105 = -1,30 \cdot 2,105 = -2,74 \text{ kN/m}$

BOČNE PODROŽNICE:

Opterećenje vjetrom:

$$W_D = w_D \cdot 2,26 \text{ m} = 1,30 \cdot 2,26 = 2,94 \text{ kN/m}$$

SPREGOVI:

Trenje po površini:

$$c_{fr} = 0,02$$

$$F_{fr} = c_{fr} \cdot q_p(z) \cdot A_{fr} = 0,02 \cdot 1,3 \cdot 19,95 \cdot 4,20 = 2,18 \text{ kN}$$

Sila na zabatnoj plohi:

Za područje B  $C_{pe} = +0,8$ ,  $C_{pi} = +0,3$

$$q_b = 1,30 \frac{\text{kN}}{\text{m}^2}$$

$$w_B = w_e - w_i = 0,8 + 0,3 = 1,1 \text{ kN/m}^2$$

$$q = q_B \cdot w_B \cdot l = 1,1 \cdot 1,30 \cdot 4,20 = 6,00 \text{ kN/m}$$

$$W_B = q \cdot \frac{h_{sr}}{2} = 6,00 \cdot \frac{7,92}{2} = 23,76 \text{ kN}$$

$$\text{Ukupna sila na spregu: } P = (F_{fr} + W_B) \cdot \gamma = (2,18 + 23,76) \cdot 1,5 = 38,91 \text{ kN}$$

Reakcija krovnog sprega:  $R = 77,82 \text{ kN}$



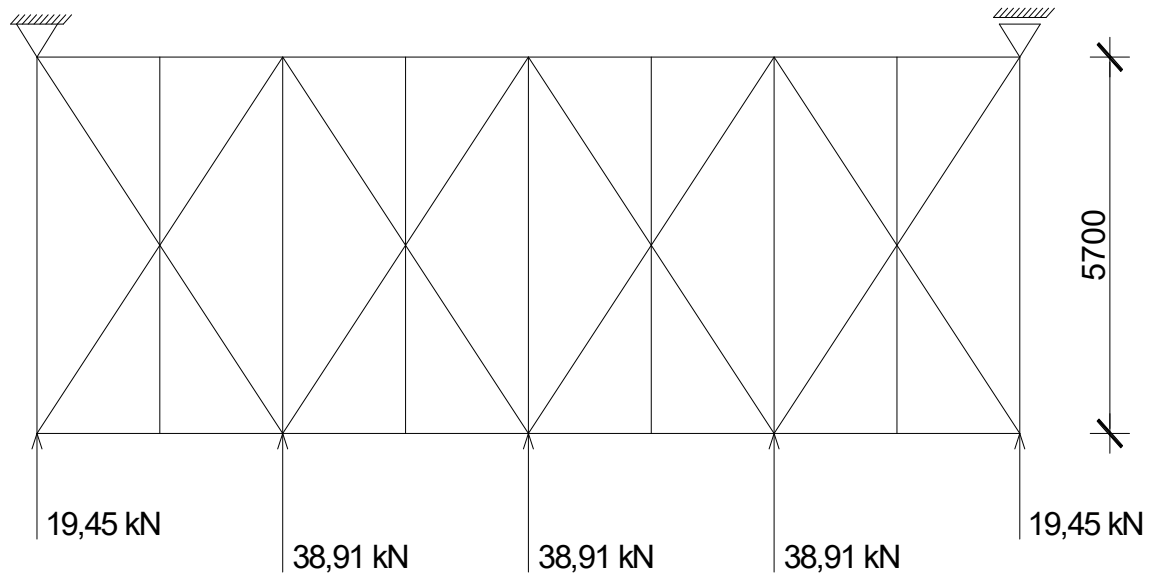

Slika 7. Raspored krovnih spregova i opterećenje

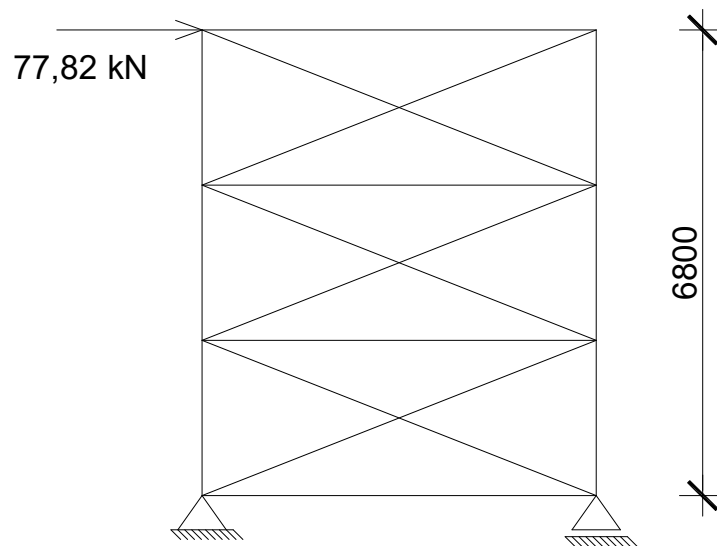

Slika 8. Raspored bočnih spregova i opterećenje

#### **4. KOMBINACIJE OPTEREĆENJA ZA GRANIČNO STANJE NOSIVOSTI I GRANIČNO STANJE UPORABLJIVOSTI**

##### **Combinations**

Name	Description	Type	Load cases	Coeff. [-]
GSN1	1,35G+1,5S	Linear - ultimate	G - vlastita teжина	1,35
			dG - dodatno stalno	1,35
			S - snijeg	1,50
GSN2	1,00G+1,5W1	Linear - ultimate	G - vlastita teжина	1,00
			dG - dodatno stalno	1,00
			W1 - v poz unut prit	1,50
GSN3	1,35G+1,5W2	Linear - ultimate	G - vlastita teжина	1,35
			dG - dodatno stalno	1,35
			W2 - v neg unut prit	1,50
GSN4	1,35G+1,5W1+0,6*1,5S	Linear - ultimate	G - vlastita teжина	1,35
			dG - dodatno stalno	1,35
			S - snijeg	0,90
			W1 - v poz unut prit	1,50
GSU1	1,0G+1,0S	Linear - serviceability	G - vlastita teжина	1,00
			dG - dodatno stalno	1,00
			S - snijeg	1,00
GSU2	1,0G+1,0W1	Linear - serviceability	G - vlastita teжина	1,00
			dG - dodatno stalno	1,00
			W1 - v poz unut prit	1,00
GSU3	1,0G+1,0W2	Linear - serviceability	G - vlastita teжина	1,00
			dG - dodatno stalno	1,00
			W2 - v neg unut prit	1,00
GSU4	1,0G+1,0W2+0,6S	Linear - serviceability	G - vlastita teжина	1,00
			dG - dodatno stalno	1,00
			S - snijeg	0,60
			W2 - v neg unut prit	1,00

## 5. GRANIČNO STANJE UPORABLJIVOSTI

Kod graničnog stanja uporabljivosti provjerava se vertikalni progib rešetke u sredini koji ne smije prekoračiti vrijednost od  $L/300$  (  $L$  duljina donjeg pojasa rešetke) i horizontalni pomak na vrhu stupa koji ne smije prekoračiti vrijednost  $H/300$  ( $H$  visina stupa). Parcijalni koeficijenti sigurnosti kod kontrole GSU su jednaki jedinici.

### 5.1. Vertikalni progib u sredini donjeg pojasa rešetke

Mjerodavna kombinacija:

(1.00\* vl. težina + 1.00\*dodatno stalno + 1.00\*snijeg):

Prikaz plana pomaka za navedenu kombinaciju:

Napomena : vrijednost progiba u mm

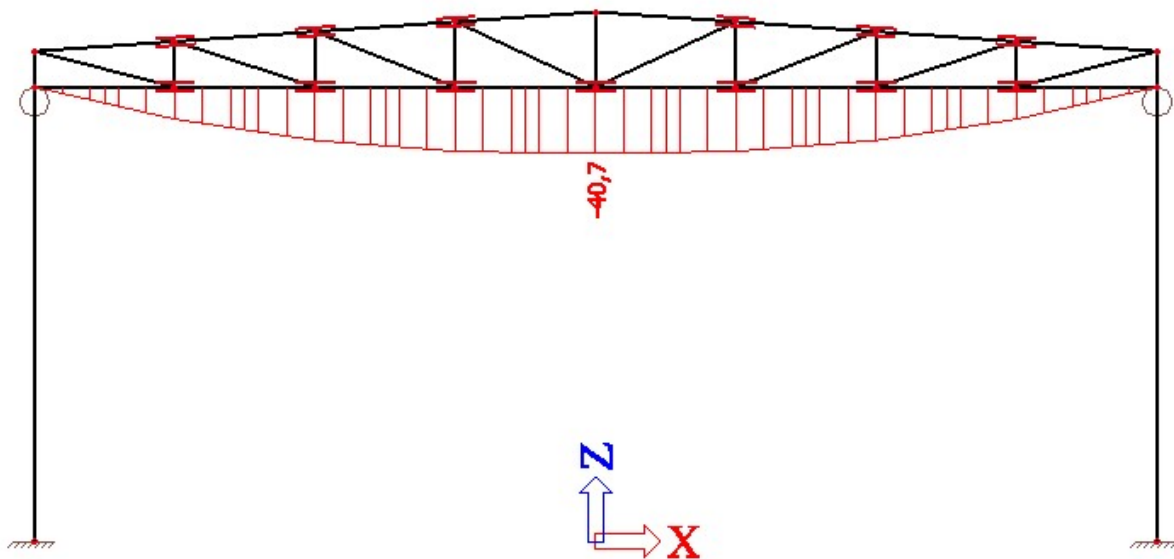

Slika 9. Vertikalni progib rešetke

Najveći progib  $\delta_{\max} = 40,7$  mm manji je od dopuštenog  $L/300 = 16800/300 = 56$  mm

**Iskoristivost 73 %**

Za gornji pojas odabran: **CFRHS 150 x 100 x 4**

Za donji pojas odabran: **CFRHS 100 x 100 x 5**

Za ispune odabran: **CFRHS 70 x 70 x 4**

## 5.2. Horizontalni pomak vrha stupa

Mjerodavna kombinacija GSU4

(1.00\* vl. težina + 1.00\*stalni teret + 1.00\*vjetar W2 + 0.60\*snijeg):

Prikaz plana pomaka za navedenu kombinaciju:

Napomena : vrijednost pomaka u mm

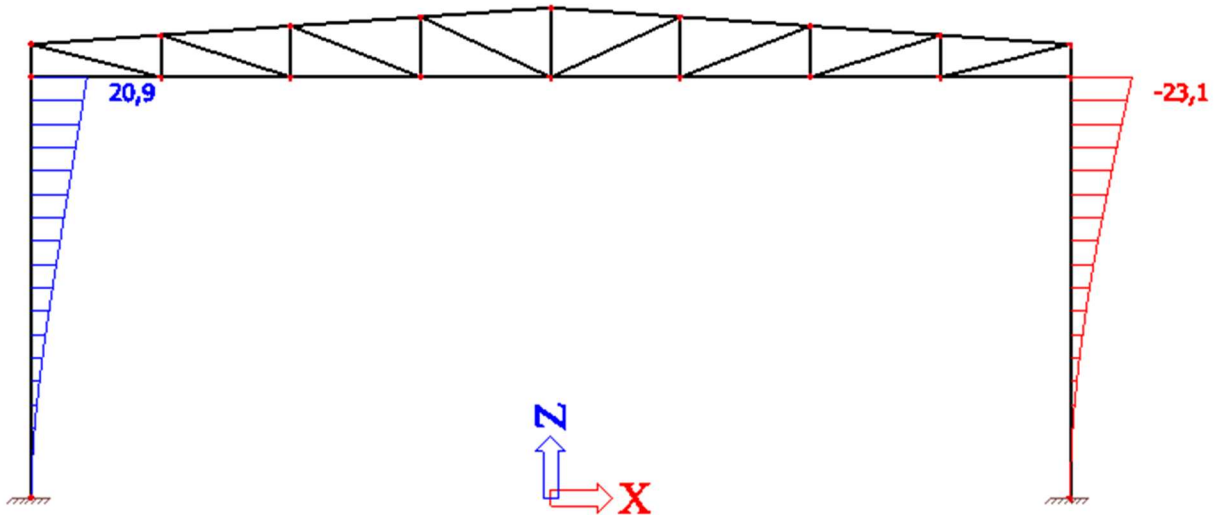

Slika 10. Horizontalni pomak stupa

Najveći pomak  $\delta_{\max}=23,1$  mm je u granicama dopuštenog  $H/300=6400/300=21,33$  mm

**Iskoristivost 108%**

Za stup odabran: **HEB 320**

**Granično stanje uporabljivosti je zadovoljeno.**

## 6. PRIKAZ REZULTATA PRORAČUNA GRANIČNOG STANJA NOSIVOSTI

### 6.1. Sekundarna bočna konstrukcija

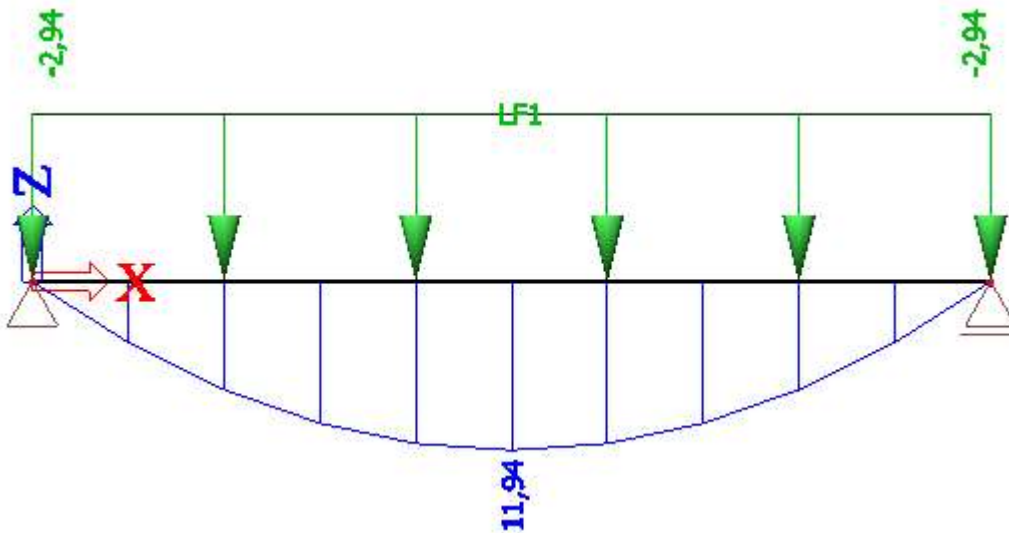

Slika 11. Moment u bočnim podrožnicama

Maksimalni moment savijanja:  $M_{Ed}=11,49$  kNm

### 6.2. Sekundarna krovna konstrukcija

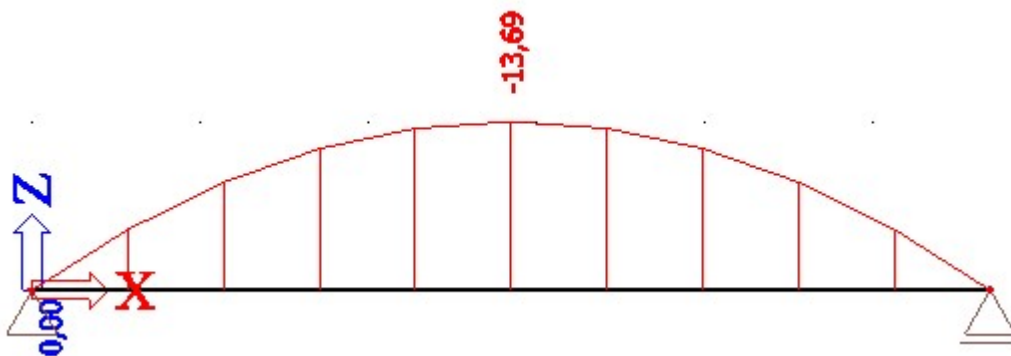

Slika 12. Moment u krovnim podrožnicama ( $1,0G+1,5W1$ )

Maksimalni moment savijanja:  $M_{Ed}=13,69$  kNm

### 6.3. Krovni vjetrovni spreg

(uzimamo samo vlačne dijagonale)

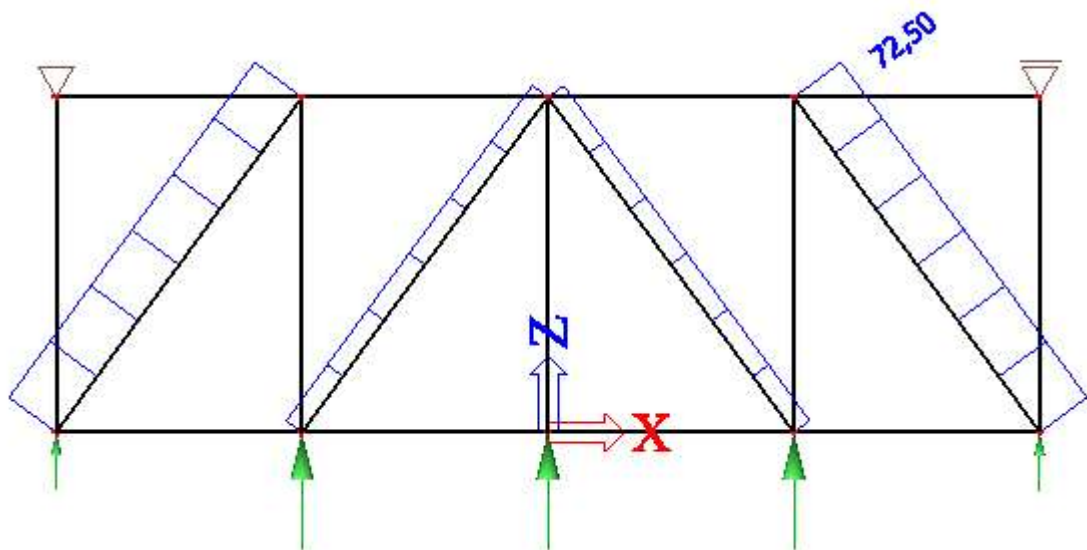

Slika 13. Uzdužne sile u krovnim spregovima

Maksimalna vlačna sila:  $N_{sd}=72,50$  kN

### 6.4. Bočni vjetrovni spreg

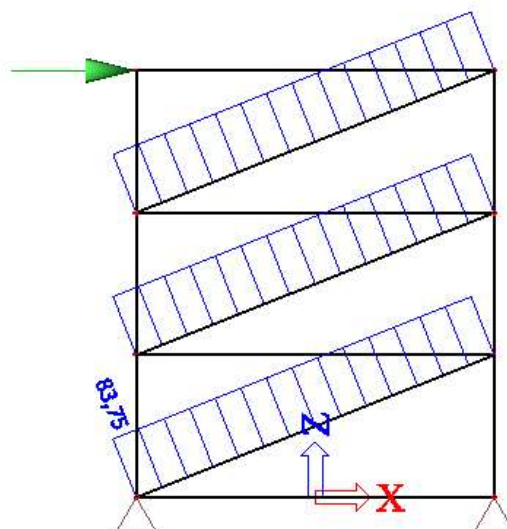

Slika 14. Uzdužne sile u bočnim spregovima

Maksimalna vlačna uzdužna sila:  $N_{Ed}=83,75$  kN

## 6.5. Maksimalne rezne sile u stupu

Mjerodavna kritična kombinacija za tlačno djelovanje (1,35 G + 1,5 S):

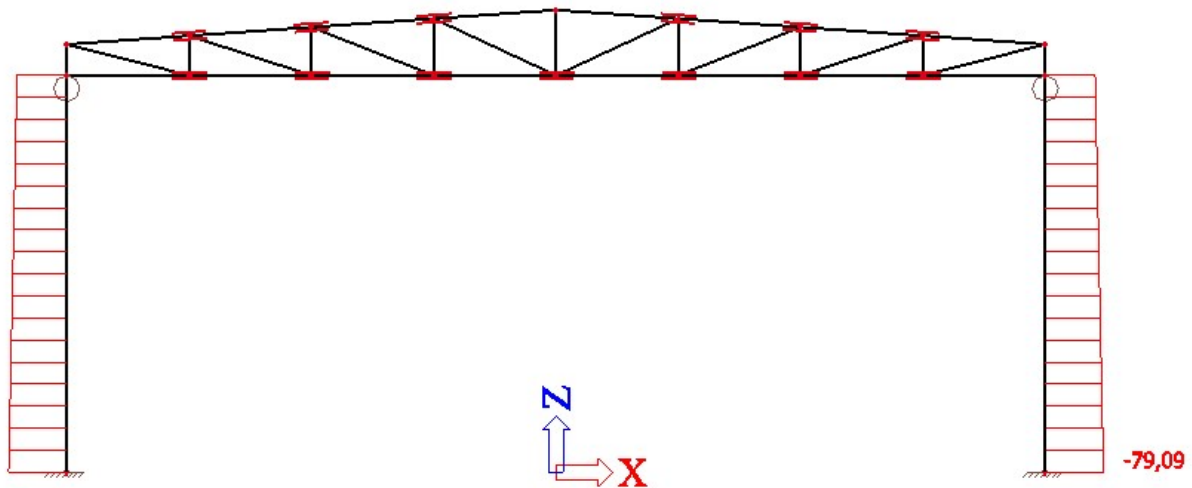

Slika 15. Maksimalna tlačna uzdužna sila u stupu

$$N_{Ed} = -79,09 \text{ kN}$$

$$V_{Ed} = -2,34 \text{ kN}$$

$$M_{Ed} = 15,45 \text{ kNm}$$

Mjerodavna kritična kombinacija za savijanje (1.0 G + 1.5 W2):

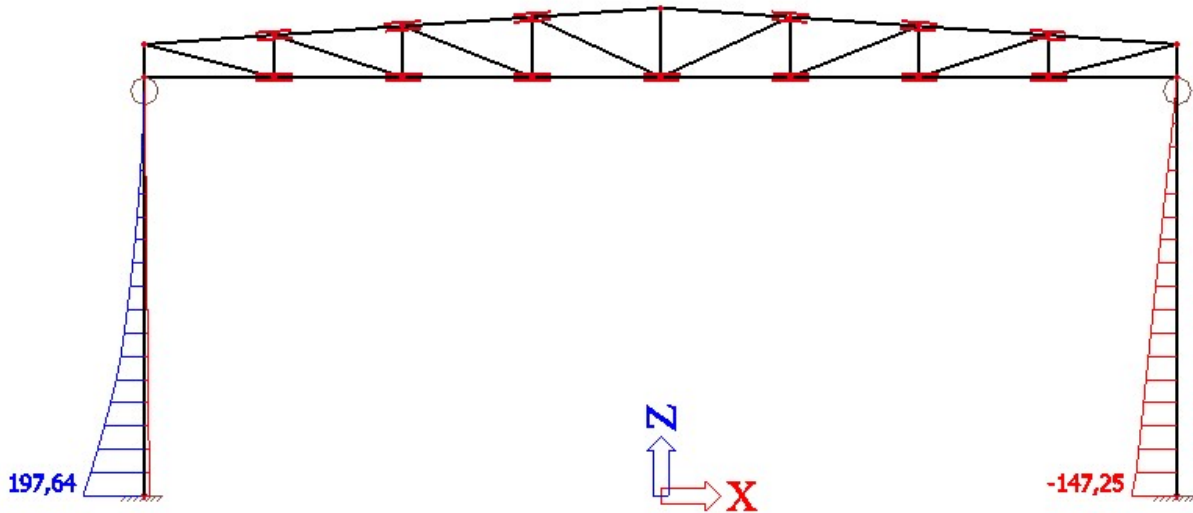

Slika 16. Anvelopa momenta u stupu

$$N_{Ed} = -36,04 \text{ kN}$$

$$V_{Ed} = -66,86 \text{ kN}$$

$$M_{Ed} = 197,64 \text{ kNm}$$



## 6.6. Maksimalne rezne sile u rešetki

Maksimalna uzdužna sila u donjem pojasu rešetke (1.35 G + 1.5 S):

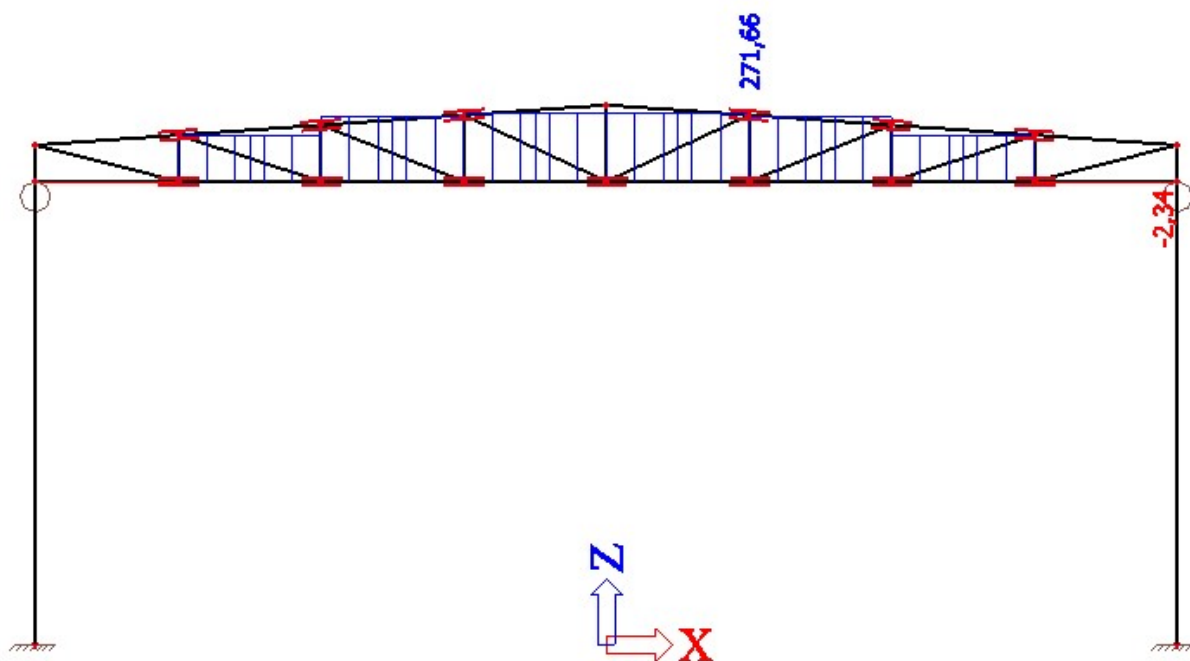

Slika 17. Anvelopa uzdužnih sila u donjem pojasu rešetke

$$N_{Ed} = 271,66 \text{ kN (vlak)}$$

$$N_{Ed} = -2,34 \text{ kN (tlak)}$$

Maksimalna uzdužna sila u gornjem pojasu rešetke:

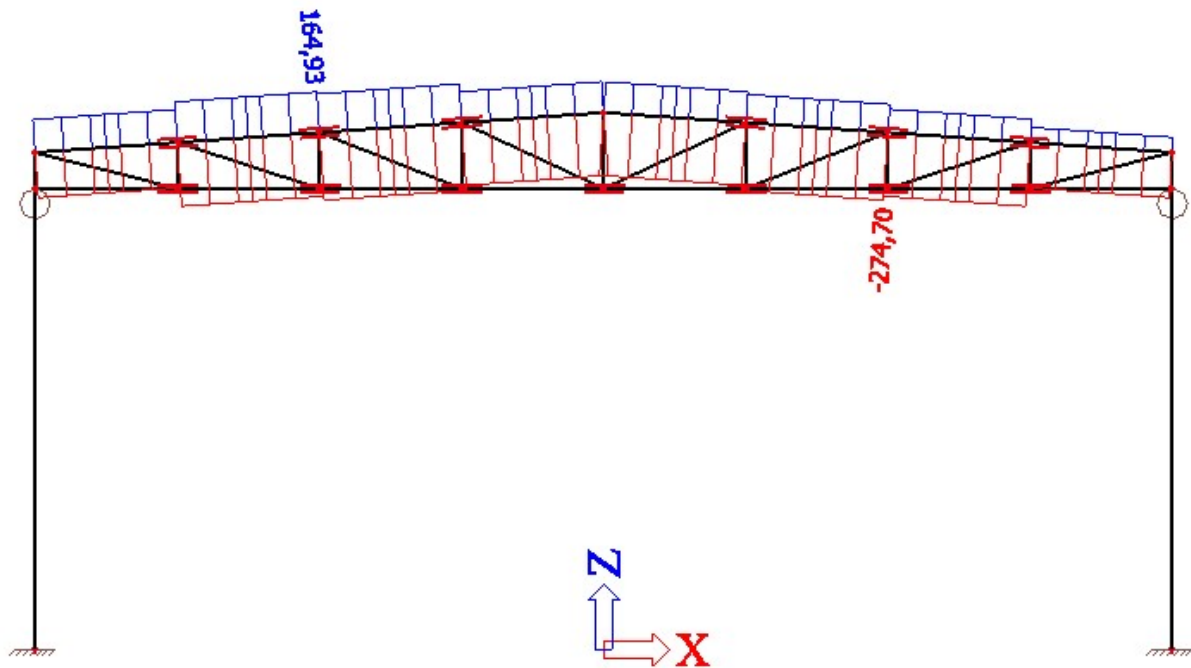

Slika 18. Anvelopa uzdužnih sila u gornjem pojasu rešetke

$$N_{Ed}=164,93 \text{ kN (vlak)}$$

$$N_{Ed}=-274,70 \text{ kN (tlak)}$$

Maksimalna uzdužna vlačna sila u ispuni rešetke (1.0 G + 1.5 S):

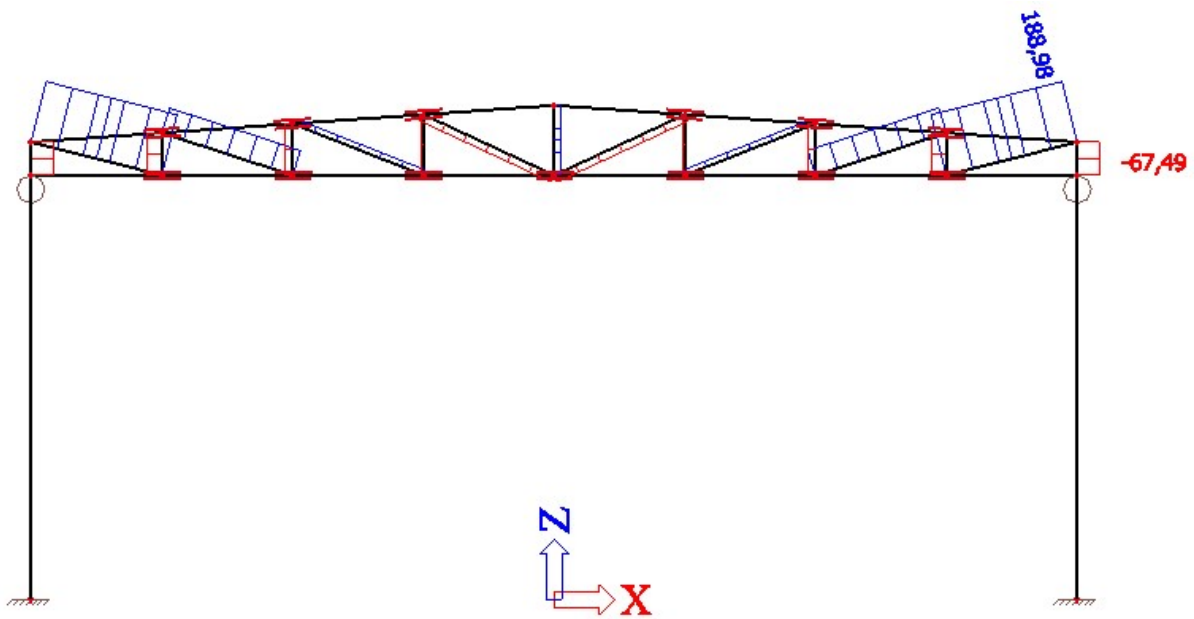

Slika 19. Maksimalna vlačna uzdužna sila u ispuni rešetke

$N_{Ed}=188,98$  kN (vlak)

Maksimalna uzdužna tlačna sila u ispuni rešetke (1.0 G + 1.5 W1):

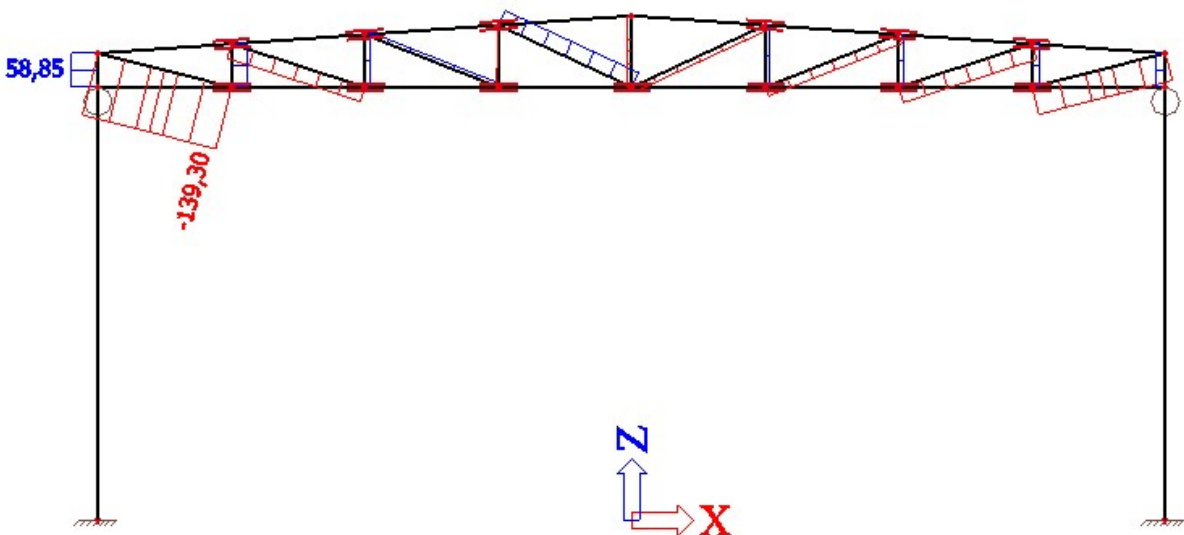

Slika 20. Maksimalna tlačna uzdužna sila u ispuni rešetke

$N_{Ed}=-139,30$  kN (tlak)

## 7. DIMENZIONIRANJE

### 7.1. Dimenzioniranje bočnih področja

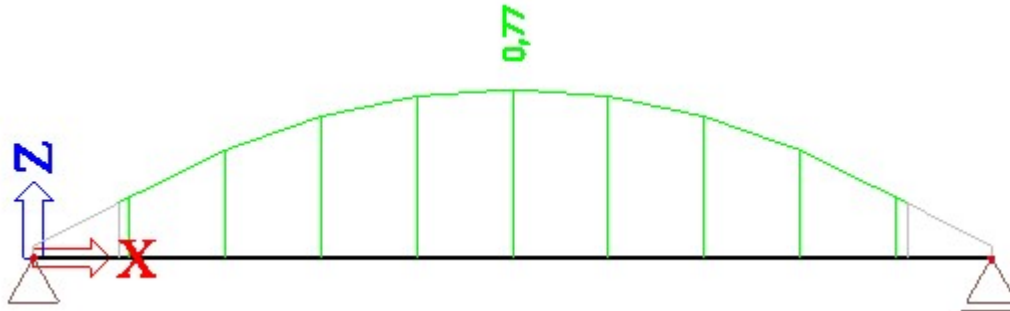

Slika 21. Iskorištenost prema GSN

Bočna področnica - IPE 180

Formcode - 1

Cross-section characteristics

A	2,3900e-03	m <sup>2</sup>
A <sub>y</sub>	1,4865e-03	m <sup>2</sup>
A <sub>z</sub>	9,6640e-04	m <sup>2</sup>
AL	6,9788e-01	m <sup>2</sup> /m
AD	6,9788e-01	m <sup>2</sup> /m
cYUCS	46	mm
cZUCS	90	mm
α	0,00	deg
I <sub>y</sub>	1,3170e-05	m <sup>4</sup>
I <sub>z</sub>	1,0100e-06	m <sup>4</sup>
i <sub>y</sub>	74	mm
i <sub>z</sub>	21	mm
W <sub>ely</sub>	1,4600e-04	m <sup>3</sup>
W <sub>elz</sub>	2,2200e-05	m <sup>3</sup>
W <sub>ply</sub>	1,6600e-04	m <sup>3</sup>
W <sub>plz</sub>	3,4600e-05	m <sup>3</sup>
M <sub>ply+</sub>	3,91e+04	Nm
M <sub>ply-</sub>	3,91e+04	Nm
M <sub>plz+</sub>	8,13e+03	Nm
M <sub>plz-</sub>	8,13e+03	Nm
d <sub>y</sub>	0	mm
d <sub>z</sub>	0	mm
I <sub>t</sub>	4,7900e-08	m <sup>4</sup>
I <sub>w</sub>	7,4300e-09	m <sup>6</sup>
β <sub>y</sub>	0	mm
β <sub>z</sub>	0	mm

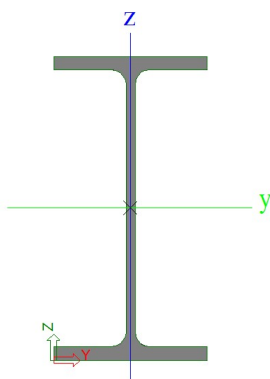





## 7.2. Dimenzioniranje krovnih področnica

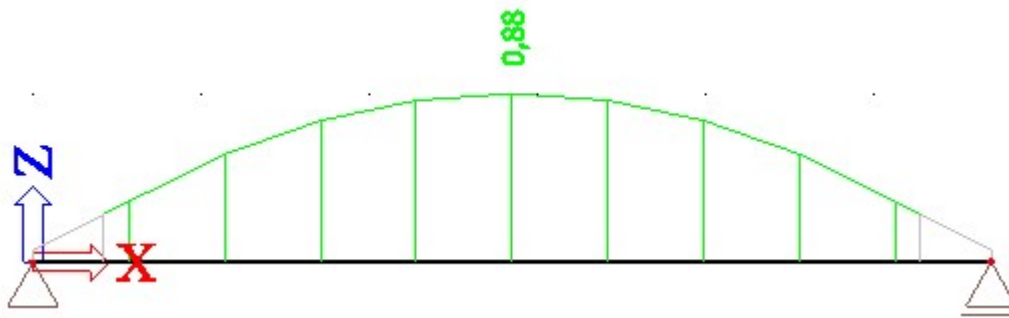

Slika 22. Iskorištenost prema GSN

Krovna področnica - IPE180

Formcode - 1

**Cross-section characteristics**

A	2,3900e-03	m <sup>2</sup>
A <sub>y</sub>	1,4865e-03	m <sup>2</sup>
A <sub>z</sub>	9,6640e-04	m <sup>2</sup>
AL	6,9788e-01	m <sup>2</sup> /m
AD	6,9788e-01	m <sup>2</sup> /m
cYUCS	46	mm
cZUCS	90	mm
α	0,00	deg
I <sub>y</sub>	1,3170e-05	m <sup>4</sup>
I <sub>z</sub>	1,0100e-06	m <sup>4</sup>
i <sub>y</sub>	74	mm
i <sub>z</sub>	21	mm
W <sub>ely</sub>	1,4600e-04	m <sup>3</sup>
W <sub>elz</sub>	2,2200e-05	m <sup>3</sup>
W <sub>ply</sub>	1,6600e-04	m <sup>3</sup>
W <sub>plz</sub>	3,4600e-05	m <sup>3</sup>
M <sub>ply+</sub>	3,91e+04	Nm
M <sub>ply-</sub>	3,91e+04	Nm
M <sub>plz+</sub>	8,13e+03	Nm
M <sub>plz-</sub>	8,13e+03	Nm
d <sub>y</sub>	0	mm
d <sub>z</sub>	0	mm
I <sub>t</sub>	4,7900e-08	m <sup>4</sup>
I <sub>w</sub>	7,4300e-09	m <sup>6</sup>
β <sub>y</sub>	0	mm
β <sub>z</sub>	0	mm

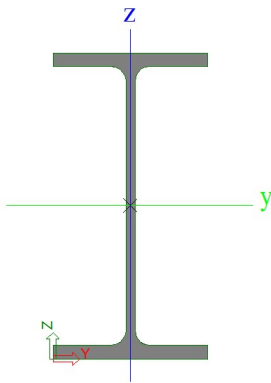







### 7.3. Dimenzioniranje krovnog sprega

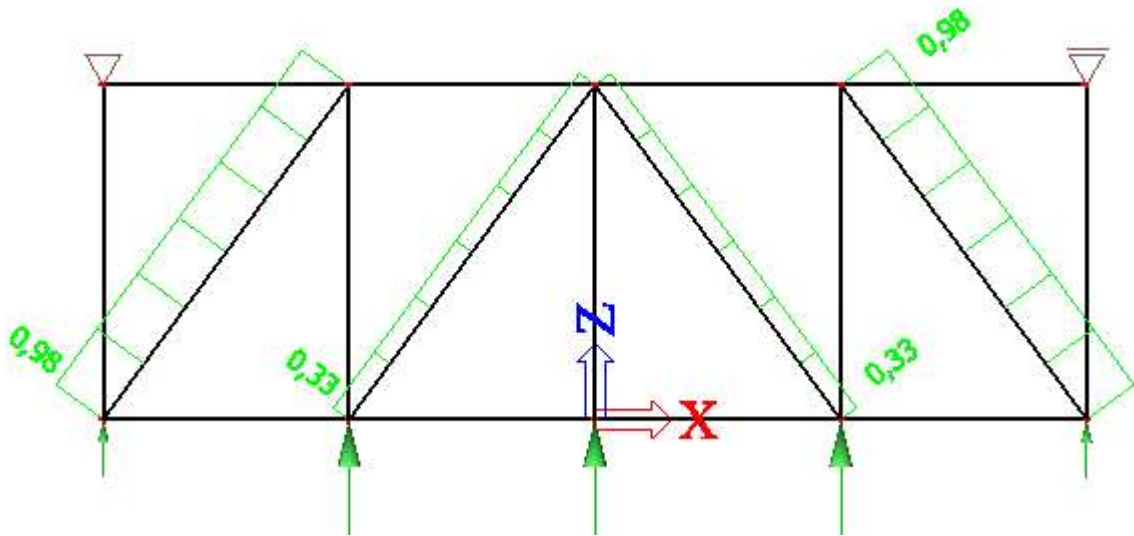

Slika 23. Iskorištenost prema GSN

Krovni spreg - RND20

Formcode - 11

#### Cross-section characteristics

A	3,1400e-04	m <sup>2</sup>
Ay	2,8194e-04	m <sup>2</sup>
Az	2,8194e-04	m <sup>2</sup>
AL	6,2800e-02	m <sup>2</sup> /m
AD	6,2829e-02	m <sup>2</sup> /m
cYUCS	10	mm
cZUCS	10	mm
α	0,00	deg
Iy	7,8500e-09	m <sup>4</sup>
Iz	7,8500e-09	m <sup>4</sup>
iy	5	mm
iz	5	mm
Wely	7,8500e-07	m <sup>3</sup>
Welz	7,8500e-07	m <sup>3</sup>
Wply	1,3300e-06	m <sup>3</sup>
Wplz	1,3300e-06	m <sup>3</sup>
Mply+	3,13e+02	Nm
Mply-	3,13e+02	Nm
Mplz+	3,13e+02	Nm
Mplz-	3,13e+02	Nm
dy	0	mm
dz	0	mm
It	1,5738e-08	m <sup>4</sup>
Iw	3,9042e-23	m <sup>6</sup>
βy	0	mm
βz	0	mm

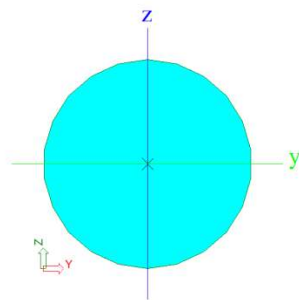



## 7.4. Dimenzioniranje bočnog sprega

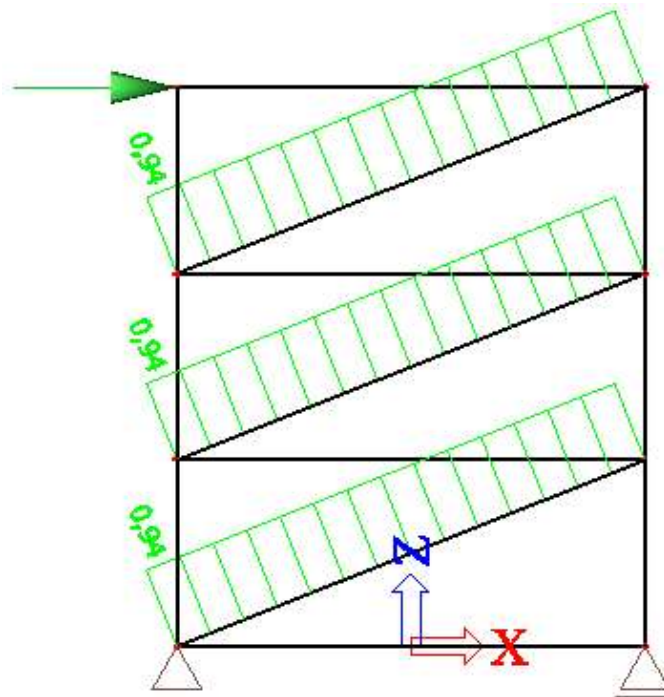

Slika 24. Iskorištenost prema GSN

Bočni spreg - RD22

Formcode - 11

### Cross-section characteristics

A	3,7994e-04	m <sup>2</sup>
Ay	3,4226e-04	m <sup>2</sup>
Az	3,4226e-04	m <sup>2</sup>
AL	6,8932e-02	m <sup>2</sup> /m
AD	6,9112e-02	m <sup>2</sup> /m
cYUCS	11	mm
cZUCS	11	mm
$\alpha$	0,00	deg
Iy	1,1258e-08	m <sup>4</sup>
Iz	1,1258e-08	m <sup>4</sup>
Iy	5	mm
Iz	5	mm
Wely	1,0235e-06	m <sup>3</sup>
Welz	1,0235e-06	m <sup>3</sup>
Wply	1,7467e-06	m <sup>3</sup>
Wplz	1,7467e-06	m <sup>3</sup>
Mply+	4,17e+02	Nm
Mply-	4,17e+02	Nm
Mplz+	4,17e+02	Nm
Mplz-	4,17e+02	Nm
dy	0	mm
dz	0	mm
It	2,3042e-08	m <sup>4</sup>
Iw	6,9165e-23	m <sup>6</sup>
$\beta_y$	0	mm
$\beta_z$	0	mm

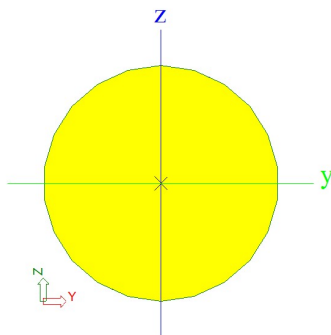



## 7.5. Dimenzioniranje gornjeg pojasa rešetke

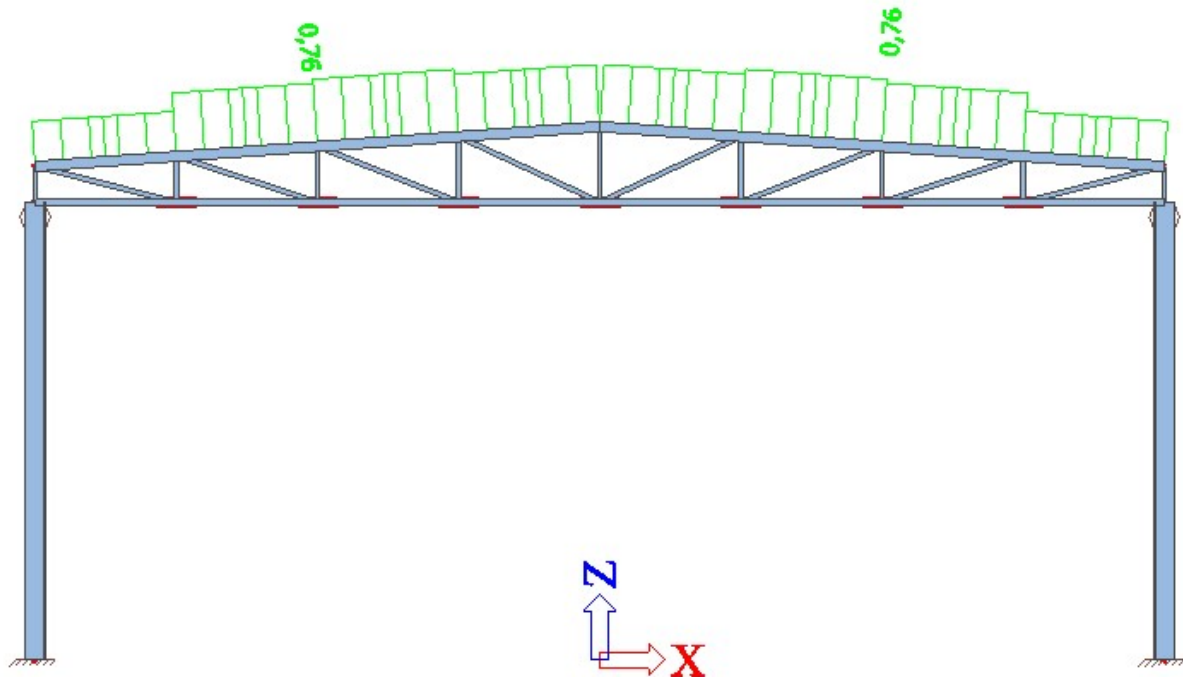

Slika 25. Iskorištenost prema GSN za kritičnu kombinaciju

gornji pojas - CFRHS150X100X4  
Formcode - 2

### Cross-section characteristics

A	1,8950e-03	m <sup>2</sup>
A <sub>y</sub>	7,5761e-04	m <sup>2</sup>
A <sub>z</sub>	1,1364e-03	m <sup>2</sup>
AL	4,8600e-01	m <sup>2</sup> /m
AD	9,4730e-01	m <sup>2</sup> /m
cYUCS	50	mm
cZUCS	75	mm
α	0,00	deg
I <sub>y</sub>	5,9460e-06	m <sup>4</sup>
I <sub>z</sub>	3,1857e-06	m <sup>4</sup>
i <sub>y</sub>	56	mm
i <sub>z</sub>	41	mm
W <sub>ely</sub>	7,9280e-05	m <sup>3</sup>
W <sub>elz</sub>	6,3710e-05	m <sup>3</sup>
W <sub>ply</sub>	9,5670e-05	m <sup>3</sup>
W <sub>plz</sub>	7,2500e-05	m <sup>3</sup>
M <sub>ply+</sub>	2,25e+04	Nm
M <sub>ply-</sub>	2,25e+04	Nm
M <sub>plz+</sub>	1,70e+04	Nm
M <sub>plz-</sub>	1,70e+04	Nm
d <sub>y</sub>	0	mm
d <sub>z</sub>	0	mm
I <sub>t</sub>	6,6163e-06	m <sup>4</sup>
I <sub>w</sub>	9,3750e-09	m <sup>6</sup>
β <sub>y</sub>	0	mm
β <sub>z</sub>	0	mm

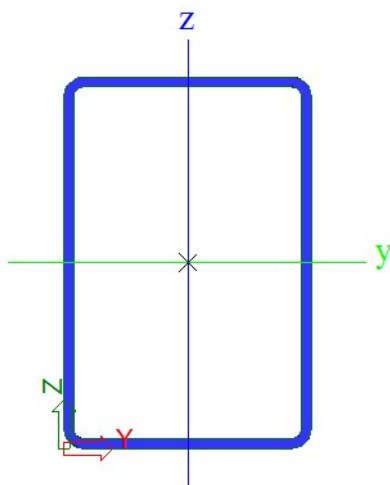







## 7.6. Dimenzioniranje donjeg pojasa rešetke

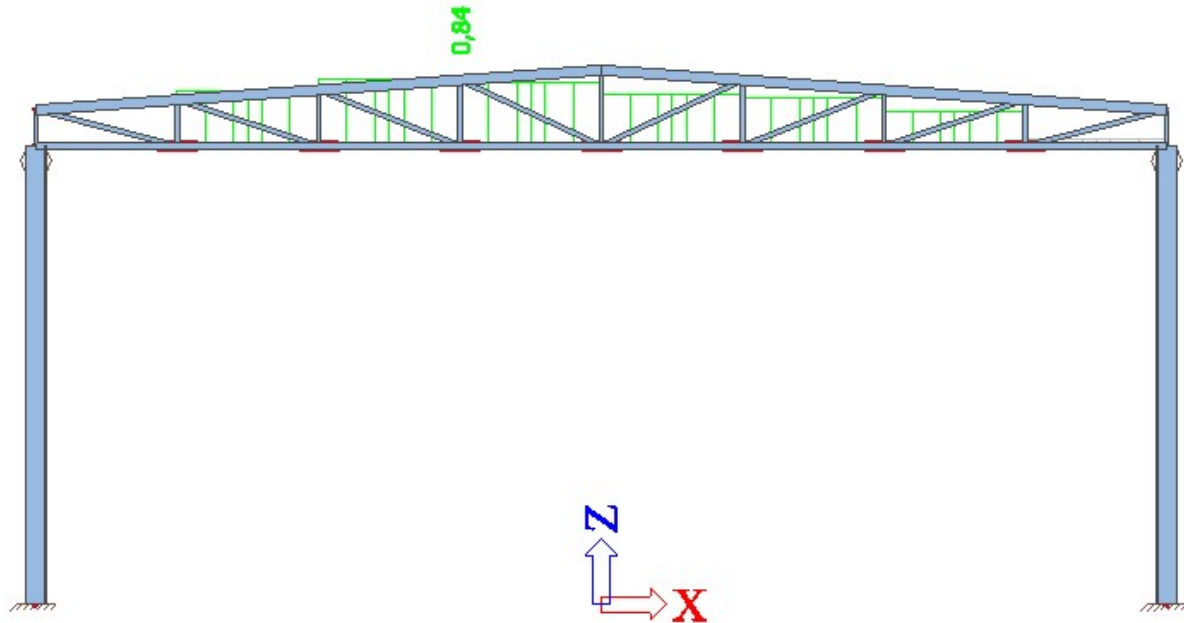

Slika 26. Iskorištenost prema GSN za kritičnu kombinaciju

donji pojas - CFRHS100X100X5  
Formcode - 2

### Cross-section characteristics

A	1,8360e-03	m <sup>2</sup>
Ay	9,1721e-04	m <sup>2</sup>
Az	9,1721e-04	m <sup>2</sup>
AL	3,8300e-01	m <sup>2</sup> /m
AD	7,3413e-01	m <sup>2</sup> /m
cYUCS	50	mm
cZUCS	50	mm
α	0,00	deg
Iy	2,7110e-06	m <sup>4</sup>
Iz	2,7110e-06	m <sup>4</sup>
Iy	38	mm
Iz	38	mm
Wely	5,4220e-05	m <sup>3</sup>
Welz	5,4220e-05	m <sup>3</sup>
Wply	6,4590e-05	m <sup>3</sup>
Wplz	6,4590e-05	m <sup>3</sup>
Mply+	1,52e+04	Nm
Mply-	1,52e+04	Nm
Mplz+	1,52e+04	Nm
Mplz-	1,52e+04	Nm
dy	0	mm
dz	0	mm
It	4,4052e-06	m <sup>4</sup>
Iw	4,1667e-09	m <sup>6</sup>
βy	0	mm
βz	0	mm

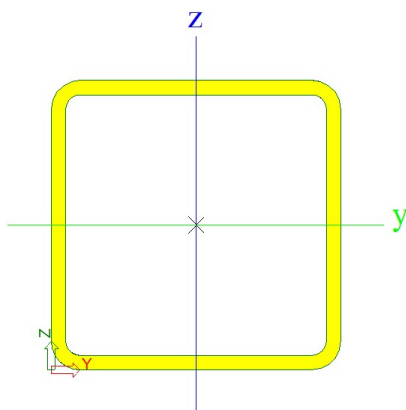





## 7.7. Dimenzioniranje ispune rešetke

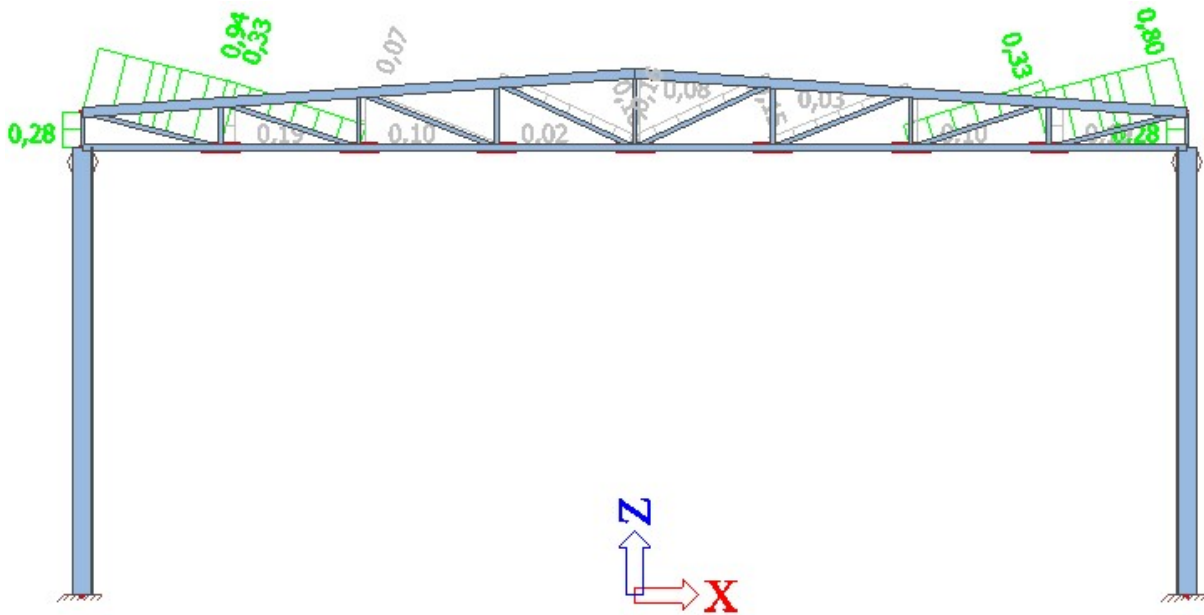

Slika 27. Iskorištenost prema GSD za kritičnu kombinaciju

ispuna - CFRHS70X70X4

Formcode - 2

### Cross-section characteristics

A	1,0150e-03	m <sup>2</sup>
A <sub>y</sub>	5,0702e-04	m <sup>2</sup>
A <sub>z</sub>	5,0702e-04	m <sup>2</sup>
AL	2,6600e-01	m <sup>2</sup> /m
AD	5,0730e-01	m <sup>2</sup> /m
cYUCS	35	mm
cZUCS	35	mm
α	0,00	deg
I <sub>y</sub>	7,2120e-07	m <sup>4</sup>
I <sub>z</sub>	7,2120e-07	m <sup>4</sup>
i <sub>y</sub>	27	mm
i <sub>z</sub>	27	mm
W <sub>ely</sub>	2,0610e-05	m <sup>3</sup>
W <sub>elz</sub>	2,0610e-05	m <sup>3</sup>
W <sub>ply</sub>	2,4760e-05	m <sup>3</sup>
W <sub>plz</sub>	2,4760e-05	m <sup>3</sup>
M <sub>ply+</sub>	5,81e+03	Nm
M <sub>ply-</sub>	5,81e+03	Nm
M <sub>plz+</sub>	5,81e+03	Nm
M <sub>plz-</sub>	5,81e+03	Nm
d <sub>y</sub>	0	mm
d <sub>z</sub>	0	mm
I <sub>t</sub>	1,1852e-06	m <sup>4</sup>
I <sub>w</sub>	5,6023e-10	m <sup>6</sup>
β <sub>y</sub>	0	mm
β <sub>z</sub>	0	mm

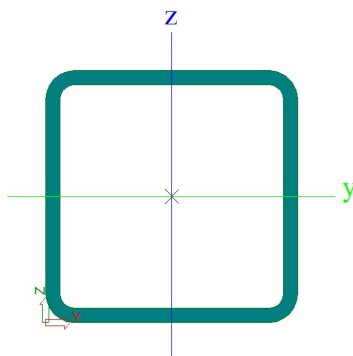





## 7.8. Dimenzioniranje stupa

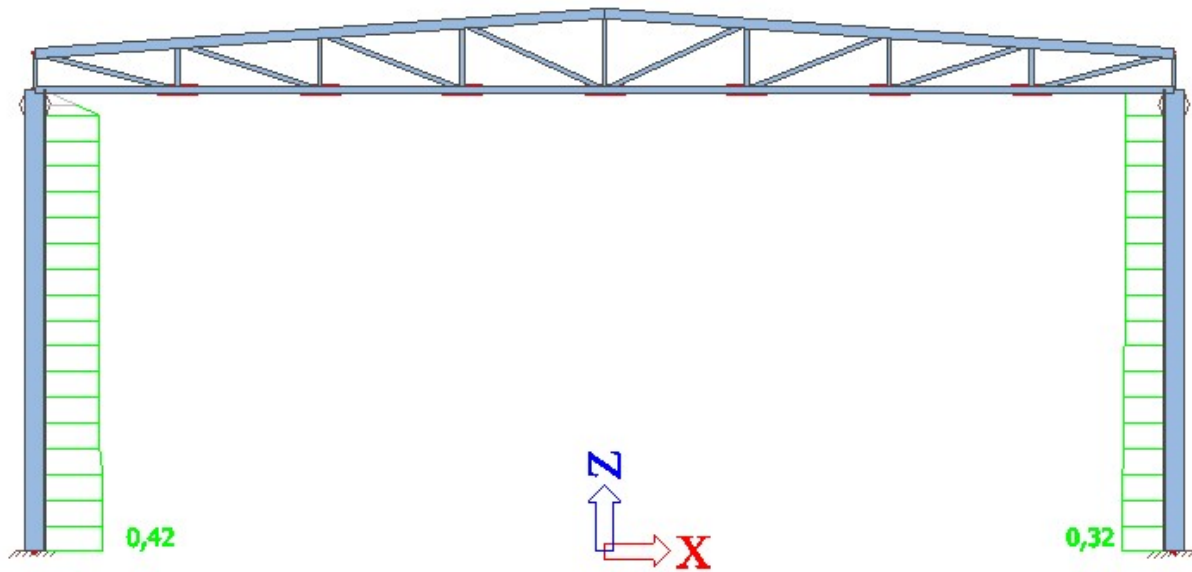

Slika 28. Iskorištenost prema GSN za kritičnu kombinaciju

stup - HEB320

Formcode - 1

**Cross-section characteristics**

A	1,6130e-02	m <sup>2</sup>
A <sub>y</sub>	1,1813e-02	m <sup>2</sup>
A <sub>z</sub>	3,9264e-03	m <sup>2</sup>
AL	1,7700e+00	m <sup>2</sup> /m
AD	1,7704e+00	m <sup>2</sup> /m
cYUCS	150	mm
cZUCS	160	mm
α	0,00	deg
I <sub>y</sub>	3,0820e-04	m <sup>4</sup>
I <sub>z</sub>	9,2390e-05	m <sup>4</sup>
i <sub>y</sub>	138	mm
i <sub>z</sub>	76	mm
W <sub>ely</sub>	1,9260e-03	m <sup>3</sup>
W <sub>elz</sub>	6,1590e-04	m <sup>3</sup>
W <sub>ply</sub>	2,1490e-03	m <sup>3</sup>
W <sub>plz</sub>	9,3910e-04	m <sup>3</sup>
M <sub>ply+</sub>	5,05e+05	Nm
M <sub>ply-</sub>	5,05e+05	Nm
M <sub>plz+</sub>	2,21e+05	Nm
M <sub>plz-</sub>	2,21e+05	Nm
d <sub>y</sub>	0	mm
d <sub>z</sub>	0	mm
I <sub>t</sub>	2,2510e-06	m <sup>4</sup>
I <sub>w</sub>	2,0687e-06	m <sup>6</sup>
β <sub>y</sub>	0	mm
β <sub>z</sub>	0	mm

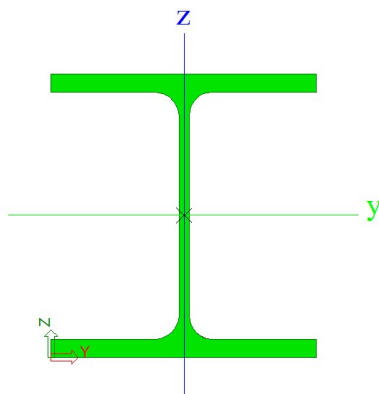











## 8. PRORAČUN SPOJEVA

### 8.1. Dimenzioniranje montažnog nastavka rešetke

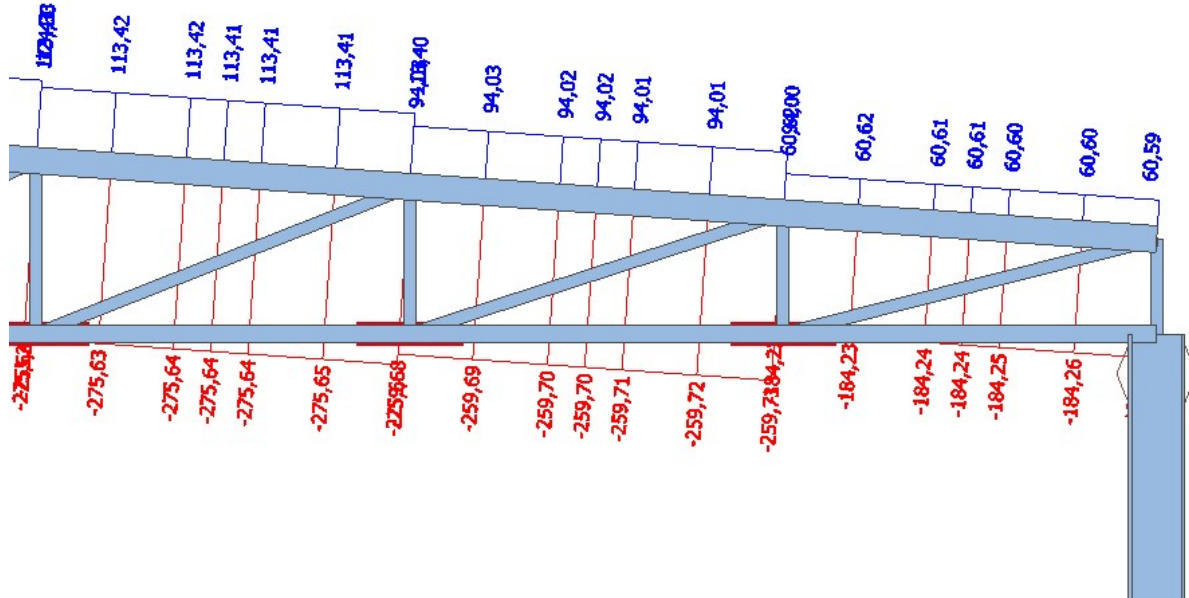

Slika X. Normalne sile u gornjem pojasu

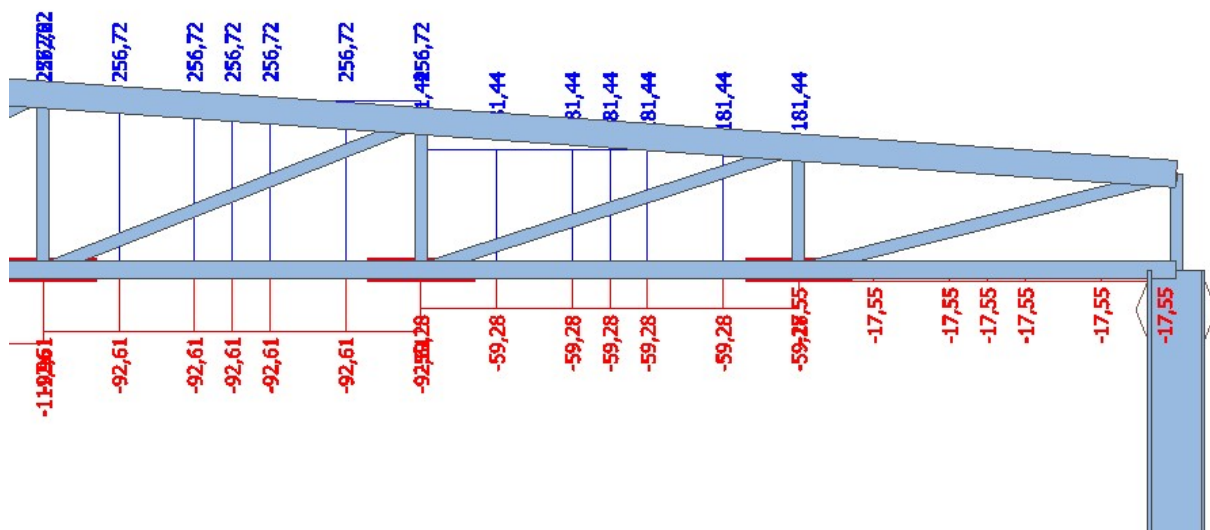

Slika X. Normalne sile u donjem pojasu

Poprečni presjek:   gornji pojas (150x100x4)  
                           donji pojas (100x100x5)

$N_{Ed}=256,72$  kN (vlak)

$N_{Ed}=-275,65$  kN (tlak)

Materijal:

Osnovni materijal: Fe-360

Vijci: k.v. 10.9

**1. Kontrola varova**Max. debljina vara

$$a_{\max} = 0,7 \cdot t_{\min} = 0,7 \cdot 5,0 = 3,5 \text{ mm}$$

$$a_{\text{odabrano}} = 3,0 \text{ mm}$$

Otpornost vara

$$L = O = 2 \cdot 150 + 2 \cdot 100 = 500 \text{ mm}$$

$$F_{w,Rd} = \frac{F_{w,Rk}}{\gamma_{M_w}} \cdot \frac{L}{100} = \frac{77,9}{1,25} \cdot \frac{500}{100} = 311,6 \text{ kN} > N_{Ed} = 256,72 \text{ kN}$$

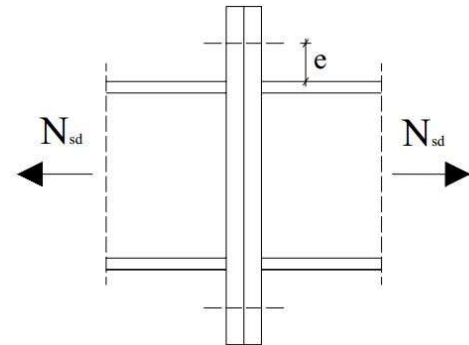
**2. Proračun vijaka**

Pretpostavljeni vijak M16; k.v. 10.9, n=4

Otpornost vijaka

$$F_{t,Rd} = \frac{F_{t,Rk}}{\gamma_{M1}} = \frac{141,3}{1,25} = 113,04 \text{ kN}$$

$$F_{t,Ed} = \frac{N_{Ed}}{n} = \frac{256,72}{4} = 64,18 \text{ kN}$$

$$F_{t,Ed} < F_{t,Rd}$$

$$64,18 \text{ kN} < 113,04 \text{ kN}$$

**3. Proračun ploče**Proračun dimenzija pločice

$$c = 2d + a\sqrt{2} = 2 \cdot 16 + 3\sqrt{2} = 36,24 \text{ mm} \approx 36 \text{ mm}$$

$$b_{pl,\min} = 2 \cdot e_2 + p_2 = 2 \cdot 30 + 155 = 215 \text{ mm}$$

$$b_{pl,\min} = b + 2 \cdot a\sqrt{2} + 20 \text{ mm} = 100 + 2 \cdot 3\sqrt{2} + 20 = 128,48 \text{ mm}$$

odabrane dim.ploče: 215x215 (mm) donji pojas

215x265 (mm) gornji pojas

Proračun min. debljine pločice

$$e = 23\text{mm}$$

$$b_{pl} = 215\text{mm}$$

$$M_{Ed} = 2 \cdot F_{t,Ed} \cdot e = 2 \cdot 64,18 \cdot 0,023 = 2,95\text{kNm}$$

$$M_{Ed} \leq \frac{W_{min} \cdot f_y}{1,0} \Rightarrow W = \frac{1,0 \cdot M_{Ed}}{f_y} = \frac{b_{pl} \cdot t_{pl}^{\min}}{6}$$

$$\Rightarrow t_{pl}^{\min} = \sqrt{\frac{1 \cdot M_{Ed} \cdot 6}{b_{pl} \cdot f_y}} = \sqrt{\frac{1 \cdot 295 \cdot 6}{21,5 \cdot 23,5}} = 1,87\text{cm}$$

$$t_{pl,oda} = 20\text{mm}$$

**Odabrana pločica: 215x215x20 (mm) donji pojas**  
**215x265x20 (mm) gornji pojas**

## 8.2. Dimenzioniranje spoja stup-rešetka

### Mjerodavna kritična kombinacija:

$$N_{sd} = 59,06 \text{ kN (vlak)}$$

### Materijal:

Osnovni materijal: Fe-510

Vijci: k.v. 10.9

### Poprečni presjek

Profil: HEB 320

$$h = 320 \text{ mm}$$

$$b = 300 \text{ mm}$$

$$t_w = 12 \text{ mm}$$

$$t_f = 22 \text{ mm}$$

-Duljina vara

$$l = 2 \cdot (300 - 10) + 2 \cdot 300 + 2 \cdot (320 - 2 \cdot 17,5) \approx 1830 \text{ mm}$$

**1. Kontrola varova**Max. debljina vara

$$a_{\max} = 0,7 \cdot t_{\min} = 0,7 \cdot 5,0 = 3,5 \text{ mm}$$

$$a_{\text{odabrano}} = 3,0 \text{ mm}$$

Otpornost vara

$$L = O = 2 \cdot 205 = 410 \text{ mm}$$

$$F_{w,Rd} = \frac{F_{w,Rk}}{\gamma_{M_w}} \cdot \frac{L}{100} = \frac{77,9}{1,25} \cdot \frac{410}{100} = 255,51 \text{ kN} > N_{Ed} = 59,06 \text{ kN}$$

**1. Vijci**Pretpostavljeni vijak M16; k.v. 10.9, n=2Otpornost vijka na vlak

$$F_{t,Rd} = \frac{F_{t,Rk}}{\gamma_{M_1}} = \frac{141,3}{1,25} = 113,04 \text{ kN} > \frac{59,06}{2} = 29,53 \text{ kN}$$

$$c_{\min} = 2 \cdot d + a\sqrt{2} = 2 \cdot 16 + 3\sqrt{2} = 36,24 \text{ mm}$$

Odabrano: c=40 mm

$$e_1 = 40 \text{ mm}$$

Proračun min. debljine pločice

$$e = 23 \text{ mm}$$

$$b_{pl} = 300 \text{ mm}$$

$$M_{Ed} = 2 \cdot F_{t,Ed} \cdot e = 2 \cdot 29,53 \cdot 0,023 = 1,35 \text{ kNm}$$

$$M_{Ed} \leq \frac{W_{\min} \cdot f_y}{1,0} \Rightarrow W = \frac{1,0 \cdot M_{Ed}}{f_y} = \frac{b_{pl} \cdot t_{pl}^{\min}}{6}$$

$$\Rightarrow t_{pl}^{\min} = \sqrt{\frac{1 \cdot M_{Ed} \cdot 6}{b_{pl} \cdot f_y}} = \sqrt{\frac{1 \cdot 1,35 \cdot 6}{30 \cdot 23,5}} = 1,07 \text{ cm}$$

$$t_{pl,oda} = 12 \text{ mm}$$

**Odabrane dimenzije ploče su 300x320x12 mm**

### 8.3. Dimenzioniranje upetog spoja stup - temelj

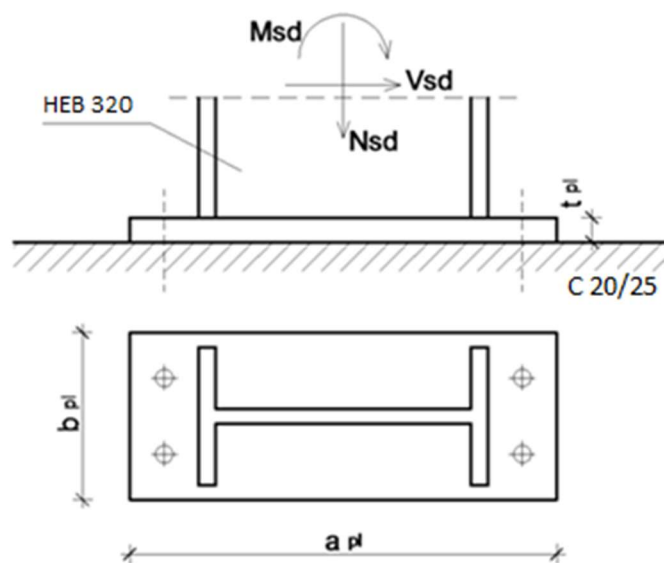

Slika 29. Skica upetog spoja stup-temelj

#### Mjerodavna kritična kombinacija

1,00 x stalno opterećenje + 1,5 x vjetar W1

$$N_{Ed} = 50,61 \text{ kN}$$

$$V_{Ed} = 42,04 \text{ kN}$$

$$M_{Ed} = 157,21 \text{ kNm}$$

#### Materijal:

Osnovni materijal: Fe-360

Vijci: k.v. 10.9

#### Poprečni presjek:

Profil: HEB 320

$h = 320 \text{ mm}$

$b = 300 \text{ mm}$

$t_w = 12 \text{ mm}$

$t_f = 22,0 \text{ mm}$



**1. Raspodjela sila po presjeku nosača:**Pojasnice:

Vlačna sila u pojasnici od momenta savijanja

$$N_p^{*M} = \frac{M_{Ed}}{h'} = \frac{157,21}{(0,32 - 0,022)} = 527,55 \text{ kN}$$

Vlačna sila u pojasnici od uzdužne sile

$$N_p^N = \frac{A_p}{A} \cdot N_{Ed} = + \frac{30 \cdot 2,1}{161,3} \cdot 50,61 = 19,76 \text{ kN}$$

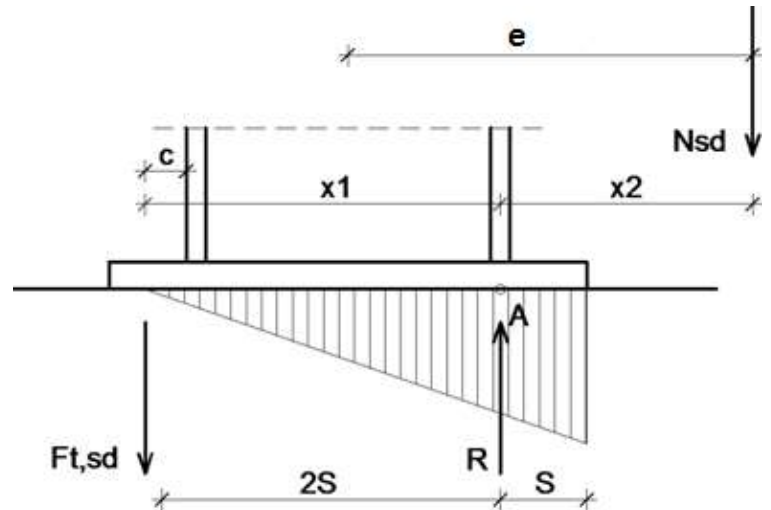

Ukupna sila u vlačnoj pojasnici

$$N_p = N_p^{*M} + N_p^N = 527,55 + 19,76 = 547,31 \text{ kN} = F_{w,Ed}$$

**2. Kontrola varova:**

Dužina vara pojasnice

$$l_1 \approx 2 \cdot 300 = 600 \text{ mm}$$

Dužina vara hrpta:

$$l_2 \approx 2 \cdot 224 = 448 \text{ mm}$$

Maksimalna debljina vara s obzirom na debljinu hrpta i pojaseva nosača

$$a_{\max} = 0,7 \cdot t_{\min} = 0,7 \cdot 12 = 8,4 \text{ mm}$$

Za pretpostavljeni var  $a=8,0 \text{ mm}$

Uzdužna sila

$$F_{w,rd} = \frac{F_{w,rk}}{\gamma_{M1}} \cdot \frac{l_1}{100} = \frac{207,8}{1,25} \cdot \frac{600}{100} = 997,44 \text{ kN} > F_{w,Ed} = 547,31 \text{ kN}$$

Poprečna sila

$$F_{w,rd} = \frac{F_{w,Rk}}{\gamma_{M1}} \cdot \frac{l_2}{100} = \frac{207,8}{1,25} \cdot \frac{448}{100} = 744,75 \text{ kN} > V_{Ed} = 42,04 \text{ kN}$$

**3. Proračun vijaka:**Pretpostavljeni vijak M 22 ; k.v. 10.9

$$c_{\min} = 2 \cdot d + a\sqrt{2} = 2 \cdot 22 + 8,4\sqrt{2} = 55,88\text{mm}$$

Usvojeni  $c = 60\text{ mm}$ .

Ekscentricitet uzdužne sile:

$$e = \frac{M_{Ed}}{N_{Ed}} = \frac{157,21}{50,61} = 3,10\text{m}$$

$$\text{Ekscentricitet } x_1 = 60 + 320 - 22 / 2 = 369\text{mm} = 0,369\text{m}$$

$$\text{Ekscentricitet } x_2 = 3100 - 320 / 2 + 22 / 2 = 2,951\text{ mm} = 2,95\text{ m}$$

Iz ravnoteže sila slijedi:

$$N_{Ed} \cdot x_2 = F_{t,Ed} \cdot x_1 \Rightarrow F_{t,Ed} = \frac{N_{Ed} \cdot x_2}{x_1} = \frac{50,61 \cdot 2,95}{0,369} = 404,60\text{kN}$$

Otpornost vijka na vlak

Vlačna sila se raspoređuje na 4 vijka

$$F_{t,rd} = \frac{F_{t,rk}}{\gamma_{M1}} = \frac{207,8}{1,25} = 166,24\text{kN} > \frac{F_{t,Ed}}{4} = \frac{404,60}{4} = 101,15\text{ kN}$$

Otpornost vijaka na posmik

Poprečna sila se raspoređuje na 4 vijaka.

$$F_{v,rd} = \frac{F_{v,rk}}{\gamma_{M1}} = \frac{151,5}{1,25} = 121,2\text{kN} > F_{v,sd} = \frac{V_{sd}}{4} = \frac{42,04}{4} = 10,51\text{kN}$$

Interakcija uzdužne i posmične sile na vijak

$$\frac{F_{t,Ed}}{1,4 \cdot F_{t,rd}} + \frac{F_{v,Ed}}{F_{v,rd}} \leq 1,0 \Rightarrow \frac{101,15}{1,4 \cdot 166,24} + \frac{10,51}{121,2} = 0,52 < 1,0$$

**4. Proračun dimenzija ploče:**Proračun širine i dužine ploče

$$a_{pl}^{\min} = h + 2 \cdot (c + e_1) = 320 + 2 \cdot (60 + 55) = 550\text{mm}$$

$$b_{pl}^{\min} = b + 2a\sqrt{2} + 20 = 300 + 2 \cdot 8,4 \cdot \sqrt{2} + 20 = 343,76 \text{ mm}$$

$$b_{pl}^{\min} = p_2 + 2 \cdot e_2 = 75 + 2 \cdot 45 = 165 \text{ mm}$$

Odabrane dimenzije širine i dužine ploče su 550x350mm

### Proračun debljine ploče

#### -Pritisak po omotaču rupe osnovnog materijala

$$F_{v,Ed} = \frac{V_{Ed}}{4} = 10,51 \text{ kN} = F_{b,Ed} < F_{b,Rd} = \frac{F_{b,Rk}}{\gamma_{Mb}} \cdot \frac{t^{pl}}{10} \Rightarrow t^{pl} > F_{b,Ed} \cdot \gamma_{Mb} \cdot 10$$

$$t^{pl} > \frac{10,51 \cdot 1,25 \cdot 10}{151,3} = 0,86 \text{ mm}$$

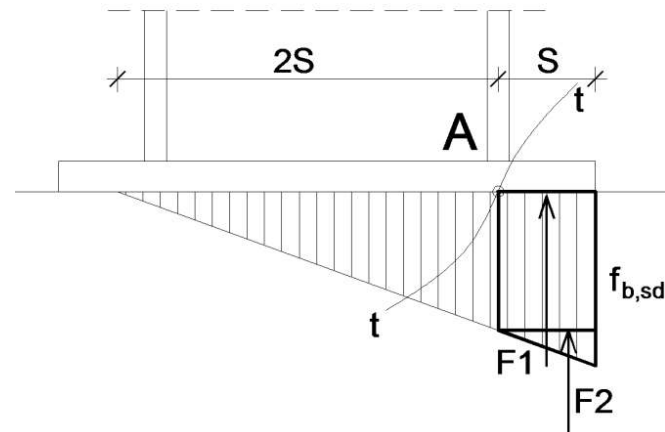

- Savijanje ploče od odgovora betonske podloge

$$S = (550 - 320 + 22) / 2 = 126,0 \text{ mm} = 12,6 \text{ cm}$$

$$R = F_{t,Ed} + N_{Ed} = 166,24 - 50,61 = 115,63 \text{ kN}$$

#### *Naprezanje na betonu*

$$f_{B,sd} = \frac{R}{\frac{3 \cdot S \cdot b_{pl}}{2}} = \frac{115,63}{\frac{3 \cdot 12,6 \cdot 35}{2}} = 0,175 \text{ kN / cm}^2 \leq \frac{f_{ck}}{1,5} = \frac{2,0}{1,5} = 1,33 \text{ kN / cm}^2$$

#### *Savijanje ploče*

$$M_{Ed} = F_1 \cdot \frac{S}{2} + F_2 \cdot \frac{3 \cdot S}{2} = \frac{2}{3} f_{B,sd} \cdot S \cdot b_{pl} \cdot \frac{S}{2} + \frac{1}{3} \cdot f_{B,sd} \cdot S \cdot b_{pl} \cdot \frac{2}{3} \cdot S =$$

$$= \frac{2}{3} \cdot 1750 \cdot 0,126 \cdot 0,35 \cdot \frac{0,126}{2} + \frac{1}{3} \cdot 1750 \cdot 0,126 \cdot 0,350 \cdot \frac{2}{3} \cdot 0,126 = 4,32 \text{ kNm} \Rightarrow \text{mjerodavno}$$

#### -Savijanje ploče od vlačnih vijaka

$$M_{sd} = F_{t,Ed} \cdot (c + t_f / 2) = 166,24 \cdot (0,06 + 0,0011) = 10,15 \text{ kNm}$$

$$M_{Ed} \leq \frac{W_{\min} \cdot f_y}{1,1} \Rightarrow W_{\min} = \frac{1,1 \cdot M_{Ed}}{f_y} = \frac{b_{pl} \cdot t_{pl}^{\min}}{6} \Rightarrow t_{pl}^{\min} = \sqrt{\frac{1,0 \cdot M_{Ed} \cdot 6}{b_{pl} \cdot f_y}} = \sqrt{\frac{1,0 \cdot 432 \cdot 6}{35 \cdot 23,5}} = 1,78 \text{ cm}$$

Odabrane dimenzije pločice su 550x 350x20

## 9. DIMENZIONIRANJE TEMELJA

- MAKSIMALNA TLAČNA SILA I PRIPADNI MOMET

### BETON

C 25/30

$\gamma_b = 24 \text{ kN/m}^3$

### ARMATURA

B 500/550

$f_{yk} = 500 \text{ N/mm}^2$

$\gamma_s = 1,15$

$f_{yd} = f_{yk} / \gamma_s = 434,8 \text{ N/mm}^2$

### TLO

$f_{tla,dop} = 0,3 \text{ MN/m}^2$

### REZNE SILE

$N = 78,57 \text{ kN}$

$M_z = 15,81 \text{ kN}$

### SILE

$A = b_x \cdot b_y = 2,56 \text{ m}^2$

$W_x = \frac{b_x \cdot b_y^2}{6} = 0,68 \text{ m}^2$

$W_y = \frac{b_y \cdot b_x^2}{6} = 0,68 \text{ m}^2$

$N_{sd} = N - \gamma_b \cdot b_x \cdot b_y \cdot d = 53,99 \text{ kN}$

$M_{sd,x} = M_x + N \cdot c_y = 0 \text{ kNm}$

$M_{sd,y} = M_y + N \cdot c_x = 15,81 \text{ kNm}$

$e_x = \frac{M_{sd,y}}{N_{sd}} = 29,28 \text{ cm}$

$e_y = \frac{M_{sd,x}}{N_{sd}} = 0 \text{ cm}$

### NAPREZANJA U TLU

$\sigma_1 = 0,00 \text{ MN/m}^2$

$\sigma_2 = 0,01397 \text{ MN/m}^2$

$\sigma_3 = 0,01397 \text{ MN/m}^2$

$\sigma_4 = 0,00 \text{ MN/m}^2$

### ARMATURA

$M_{1-1} = 0 \text{ kNm}$

$M_{2-2} = 0,38 \text{ kNm}$

$M_{3-3} = -4,48 \text{ kNm}$

$M_{4-4} = -4,48 \text{ kNm}$

$A_{sx} = \frac{M_{2-2}}{0,9 \cdot d \cdot f_{yd}} = 0,03 \text{ cm}^2$

$A_{sy} = \frac{M_{3-3}}{0,9 \cdot d \cdot f_{yd}} = 0,33 \text{ cm}^2$

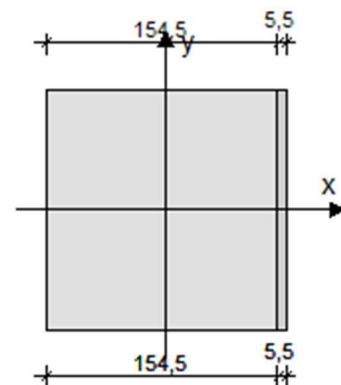
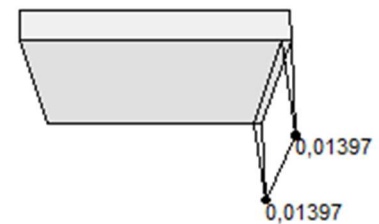
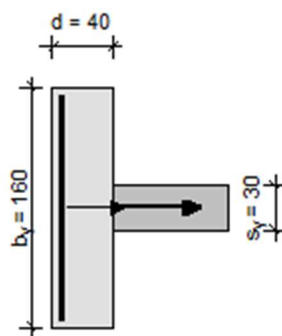
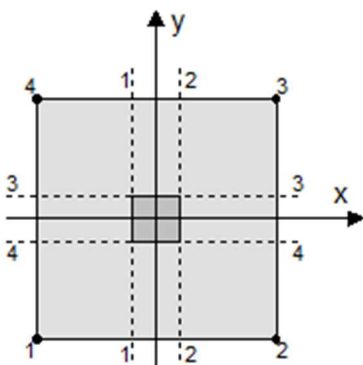
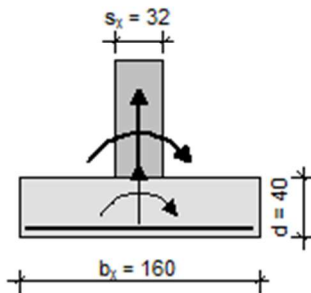

## MAKSIMALNI MOMENT I PRIPADNA NORMALNA SILA

**BETON**

C 25/30

 $\gamma_b = 24 \text{ kN/m}^3$ **ARMATURA**

B 500/550

 $f_{yk} = 500 \text{ N/mm}^2$  $\gamma_s = 1,15$  $f_{yd} = f_{yk} / \gamma_s = 434,8 \text{ N/mm}^2$ **TLO** $f_{tla,dop} = 0,3 \text{ MN/m}^2$ **REZNE SILE** $N = 10,48 \text{ kN}$  $M_z = 197,77 \text{ kN}$ **SILE**

$$A = b_x \cdot b_y = 2,56 \text{ m}^2$$

$$W_x = \frac{b_x \cdot b_y^2}{6} = 0,68 \text{ m}^2$$

$$W_y = \frac{b_y \cdot b_x^2}{6} = 0,68 \text{ m}^2$$

$$N_{sd} = N - \gamma_b \cdot b_x \cdot b_y \cdot d = -14,1 \text{ kN}$$

$$M_{sd,x} = M_x + N \cdot c_y = 0 \text{ kNm}$$

$$M_{sd,y} = M_y + N \cdot c_x = 197,77 \text{ kNm}$$

$$e_x = \frac{M_{sd,y}}{N_{sd}} = -1403,02 \text{ cm}$$

$$e_y = \frac{M_{sd,x}}{N_{sd}} = 0 \text{ cm}$$

**NAPREZANJA U TLU**

$$\sigma_1 = 0,00 \text{ MN/m}^2$$

$$\sigma_2 = 0,29521 \text{ MN/m}^2$$

$$\sigma_3 = 0,29521 \text{ MN/m}^2$$

$$\sigma_4 = 0,00 \text{ MN/m}^2$$

**ARMATURA**

$$M_{1-1} = 0 \text{ kNm}$$

$$M_{2-2} = 71,42 \text{ kNm}$$

$$M_{3-3} = -23,52 \text{ kNm}$$

$$M_{4-4} = -23,52 \text{ kNm}$$

$$A_{sx} = \frac{M_{2-2}}{0,9 \cdot d \cdot f_{yd}} = 5,21 \text{ cm}^2$$

$$A_{sy} = \frac{M_{3-3}}{0,9 \cdot d \cdot f_{yd}} = 1,72 \text{ cm}^2$$

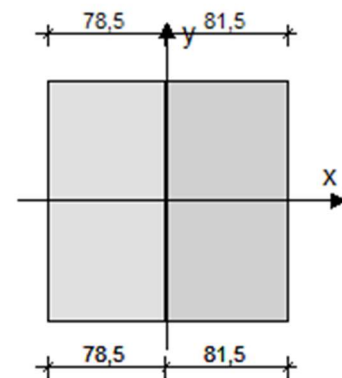
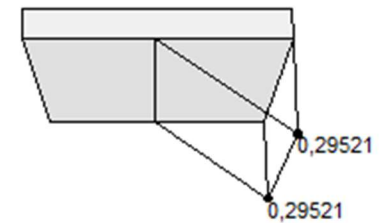
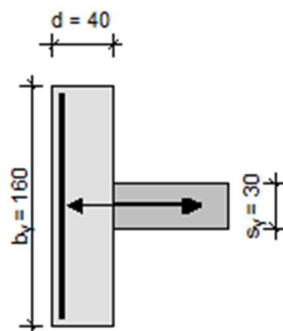
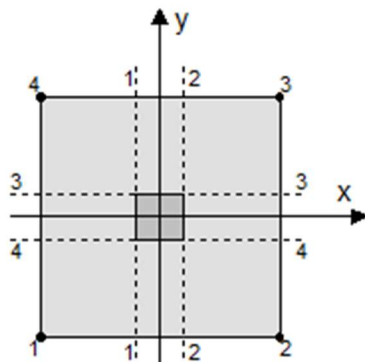
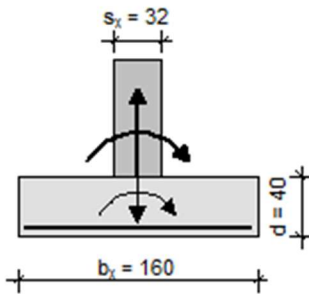

## **10. GRAFIČKI PRILOZI**

- 10.1. Generalni plan pozicija M 1:200**
- 10.2. Presjek kroz glavni okvir M 1:50**
- 10.3. Detalji spojeva M 1:10**
- 10.4. Iskaz količine čelika**

<b>Member B1</b>	<b>5,700 m</b>	<b>IPE180</b>	<b>S 235</b>	<b>W</b>	<b>0,77 -</b>
------------------	----------------	---------------	--------------	----------	---------------

<b>Partial safety factors</b>	
Gamma M0 for resistance of cross-sections	1,00
Gamma M1 for resistance to instability	1,00
Gamma M2 for resistance of net sections	1,25

<b>Material</b>		
Yield strength $f_y$	235,0	MPa
Ultimate strength $f_u$	360,0	MPa
Fabrication	Rolled	

....:SECTION CHECK:....

The critical check is on position **2.850 m**

<b>Internal forces</b>	<b>Calculated</b>	<b>Unit</b>
N,Ed	0,00	kN
V <sub>y</sub> ,Ed	0,00	kN
V <sub>z</sub> ,Ed	0,00	kN
T,Ed	0,00	kNm
M <sub>y</sub> ,Ed	11,94	kNm
M <sub>z</sub> ,Ed	0,00	kNm

**Classification for cross-section design**

According to EN 1993-1-1 article 5.5.2

**Classification of Internal Compression parts**

According to EN 1993-1-1 Table 5.2 Sheet 1

Maximum width-to-thickness ratio	27,55
Class 1 Limit	72,00
Class 2 Limit	83,00
Class 3 Limit	124,00

=> Internal Compression parts Class 1

**Classification of Outstand Flanges**

According to EN 1993-1-1 Table 5.2 Sheet 2

Maximum width-to-thickness ratio	4,23
Class 1 Limit	9,00
Class 2 Limit	10,00
Class 3 Limit	13,77

=> Outstand Flanges Class 1

=> Section classified as Class 1 for cross-section design

**Bending moment check for M<sub>y</sub>**

According to EN 1993-1-1 article 6.2.5 and formula (6.12),(6.13)

Wpl,y	1,6600e-04	m <sup>3</sup>
Mpl,y,Rd	39,01	kNm
Unity check	0,31	-

The member satisfies the section check.

....:STABILITY CHECK:....

**Classification for member buckling design**

Decisive position for stability classification: 0,570 m

**Classification of Internal Compression parts**

According to EN 1993-1-1 Table 5.2 Sheet 1

Maximum width-to-thickness ratio	27,55
Class 1 Limit	72,00
Class 2 Limit	83,00
Class 3 Limit	124,00

=> Internal Compression parts Class 1

**Classification of Outstand Flanges**

According to EN 1993-1-1 Table 5.2 Sheet 2

Maximum width-to-thickness ratio	4,23
----------------------------------	------

*\*Student version\* \*Student version\* \*Student version\* \*Student ve*

Class 1 Limit	9,00
Class 2 Limit	10,00
Class 3 Limit	13,77

=> Outstand Flanges Class 1  
=> Section classified as Class 1 for member buckling design

#### Lateral Torsional Buckling check

According to EN 1993-1-1 article 6.3.2.1 & 6.3.2.2 and formula (6.54)

LTB parameters	
<i>*Student version* *Student version* *Student version* *Student version* *Student version* *Stu</i>	

LTB parameters		
Method for LTB curve	General case	
Cross-section plastic modulus $W_{pl,y}$	1,6600e-04	m <sup>3</sup>
Elastic critical moment $M_{cr}$	18,85	kNm
Relative slenderness $\lambda_{rel,LT}$	1,44	
Limit slenderness $\lambda_{rel,LT,0}$	0,20	
LTB curve	a	
Imperfection $\alpha_{LT}$	0,21	
Reduction factor $\chi_{LT}$	0,40	
Design buckling resistance $M_{b,Rd}$	15,59	kNm
Unity check	0,77	-

Mcr parameters	
<i>*Student version* *Student version* *Student version* *Student version* *Student ver</i>	

LTB length L	5,700	m
Influence of load position	no influence	
Correction factor k	1,00	
Correction factor $k_w$	1,00	
LTB moment factor C1	1,13	
LTB moment factor C2	0,45	
LTB moment factor C3	0,53	
Shear center distance d,z	0	mm
Distance of load application z,g	0	mm
Mono-symmetry constant $\beta_{a,y}$	0	mm
Mono-symmetry constant z,j	0	mm

**Note:** C parameters are determined according to ECCS 119 2006 / Galea 2002.  
The member satisfies the stability check.



Member B1	5,700 m	IPE180	S 235	GSN2	0,88 -
-----------	---------	--------	-------	------	--------

Partial safety factors	
Gamma M0 for resistance of cross-sections	1,00
Gamma M1 for resistance to instability	1,00
Gamma M2 for resistance of net sections	1,25

Material	
Yield strength $f_y$	235,0 MPa
Ultimate strength $f_u$	360,0 MPa
Fabrication	Rolled

....SECTION CHECK:....

The critical check is on position 2.850 m

Internal forces	Calculated	Unit
N,Ed	0,00	kN
V <sub>y</sub> ,Ed	0,00	kN
V <sub>z</sub> ,Ed	0,00	kN
T,Ed	0,00	kNm
M <sub>y</sub> ,Ed	-13,69	kNm
M <sub>z</sub> ,Ed	0,00	kNm

**Classification for cross-section design**

According to EN 1993-1-1 article 5.5.2

**Classification of Internal Compression parts**

According to EN 1993-1-1 Table 5.2 Sheet 1

Maximum width-to-thickness ratio	27,55
Class 1 Limit	72,00
Class 2 Limit	83,00
Class 3 Limit	124,00

=> Internal Compression parts Class 1

**Classification of Outstand Flanges**

According to EN 1993-1-1 Table 5.2 Sheet 2

Maximum width-to-thickness ratio	4,23
Class 1 Limit	9,00
Class 2 Limit	10,00
Class 3 Limit	13,77

=> Outstand Flanges Class 1

=> Section classified as Class 1 for cross-section design

**Bending moment check for M<sub>y</sub>**

According to EN 1993-1-1 article 6.2.5 and formula (6.12),(6.13)

Wpl,y	1,6600e-04	m <sup>3</sup>
Mpl,y,Rd	39,01	kNm
Unity check	0,35	-

The member satisfies the section check.

....STABILITY CHECK:....

**Classification for member buckling design**

Decisive position for stability classification: 0,570 m

**Classification of Internal Compression parts**

According to EN 1993-1-1 Table 5.2 Sheet 1

Maximum width-to-thickness ratio	27,55
Class 1 Limit	72,00
Class 2 Limit	83,00
Class 3 Limit	124,00

=> Internal Compression parts Class 1

**Classification of Outstand Flanges**

According to EN 1993-1-1 Table 5.2 Sheet 2

Maximum width-to-thickness ratio	4,23
----------------------------------	------

\*Student version\* \*Student version\* \*Student version\* \*Student ve.

Class 1 Limit	9,00
Class 2 Limit	10,00
Class 3 Limit	13,77

=> Outstand Flanges Class 1  
=> Section classified as Class 1 for member buckling design

#### Lateral Torsional Buckling check

According to EN 1993-1-1 article 6.3.2.1 & 6.3.2.2 and formula (6.54)

LTB parameters	
<i>*Student version* *Student version* *Student version* *Student version* *Student version* *Stu</i>	

Method for LTB curve	General case	
Cross-section plastic modulus $W_{pl,y}$	1,6600e-04	m <sup>3</sup>
Elastic critical moment $M_{cr}$	18,85	kNm
Relative slenderness $\lambda_{rel,LT}$	1,44	
Limit slenderness $\lambda_{rel,LT,0}$	0,20	
LTB curve	a	
Imperfection $\alpha_{LT}$	0,21	
Reduction factor $\chi_{LT}$	0,40	
Design buckling resistance $M_{b,Rd}$	15,59	kNm
Unity check	0,88	-

Mcr parameters	
<i>*Student version* *Student version* *Student version* *Student version* *Student ver</i>	

LTB length L	5,700	m
Influence of load position	no influence	
Correction factor k	1,00	
Correction factor $k_w$	1,00	
LTB moment factor C1	1,13	
LTB moment factor C2	0,45	
LTB moment factor C3	0,53	
Shear center distance d,z	0	mm
Distance of load application z,g	0	mm
Mono-symmetry constant $\beta_{a,y}$	0	mm
Mono-symmetry constant z,j	0	mm

**Note:** C parameters are determined according to ECCS 119 2006 / Galea 2002.  
The member satisfies the stability check.

Member B9	7,080 m	RND20	S 235	P	0,98 -
-----------	---------	-------	-------	---	--------

Partial safety factors	
Gamma M0 for resistance of cross-sections	1,00
Gamma M1 for resistance to instability	1,00
Gamma M2 for resistance of net sections	1,25

Material		
Yield strength $f_y$	235,0	MPa
Ultimate strength $f_u$	360,0	MPa
Fabrication	Rolled	

**Warning:** Strength reduction in function of the thickness is not supported for this type of cross-section.

.....SECTION CHECK:....

The critical check is on position 0.000 m

Internal forces	Calculated	Unit
N,Ed	72,50	kN
Vy,Ed	0,00	kN
Vz,Ed	0,00	kN
T,Ed	0,00	kNm
My,Ed	0,00	kNm
Mz,Ed	0,00	kNm

#### Classification for cross-section design

According to EN 1993-1-1 article 5.5.2

**Warning:** Classification is not supported for this type of cross-section.

The section is checked as elastic, class 3.

#### Tension check

According to EN 1993-1-1 article 6.2.3 and formula (6.5)

A	3,1400e-04	m <sup>2</sup>
Npl,Rd	73,79	kN
Nu,Rd	81,39	kN
Nt,Rd	73,79	kN
Unity check	0,98	-

The member satisfies the section check.

.....STABILITY CHECK:....

The member satisfies the stability check.

Member B7	6,134 m	RD22	S 235	R	0,94 -
-----------	---------	------	-------	---	--------

Partial safety factors	
Gamma M0 for resistance of cross-sections	1,00
Gamma M1 for resistance to instability	1,00
Gamma M2 for resistance of net sections	1,25

Material		
Yield strength $f_y$	235,0	MPa
Ultimate strength $f_u$	360,0	MPa
Fabrication	Rolled	

**Warning:** Strength reduction in function of the thickness is not supported for this type of cross-section.

.....SECTION CHECK:....

The critical check is on position 0.000 m

Internal forces	Calculated	Unit
N,Ed	83,74	kN
Vy,Ed	0,00	kN
Vz,Ed	0,00	kN
T,Ed	0,00	kNm
My,Ed	0,00	kNm
Mz,Ed	0,00	kNm

#### Classification for cross-section design

According to EN 1993-1-1 article 5.5.2

**Warning:** Classification is not supported for this type of cross-section.

The section is checked as elastic, class 3.

#### Tension check

According to EN 1993-1-1 article 6.2.3 and formula (6.5)

A	3,7994e-04	m <sup>2</sup>
Npl,Rd	89,29	kN
Nu,Rd	98,48	kN
Nt,Rd	89,29	kN
Unity check	0,94	-

The member satisfies the section check.

.....STABILITY CHECK:....

The member satisfies the stability check.

Member B9	8,421 m	CFRHS150X100X4	S 235	GSN1	0,76 -
-----------	---------	----------------	-------	------	--------

Note: EN 1993-1-3 article 1.1(3) specifies that this part does not apply to cold formed CHS and RHS sections. The default EN 1993-1-1 code check is executed instead of the EN 1993-1-3 code check.

Partial safety factors	
Gamma M0 for resistance of cross-sections	1,00
Gamma M1 for resistance to instability	1,00
Gamma M2 for resistance of net sections	1,25

Material		
Yield strength $f_y$	235,0	MPa
Ultimate strength $f_u$	360,0	MPa
Fabrication	Cold formed	

....SECTION CHECK:....

The critical check is on position 4.210 m

Internal forces	Calculated	Unit
N,Ed	-275,66	kN
V <sub>y</sub> ,Ed	0,00	kN
V <sub>z</sub> ,Ed	0,00	kN
T,Ed	0,00	kNm
M <sub>y</sub> ,Ed	0,00	kNm
M <sub>z</sub> ,Ed	0,00	kNm

**Classification for cross-section design**

According to EN 1993-1-1 article 5.5.2

**Classification of Internal Compression parts**

According to EN 1993-1-1 Table 5.2 Sheet 1

Maximum width-to-thickness ratio	34,50
Class 1 Limit	33,00
Class 2 Limit	38,00
Class 3 Limit	42,00

=> Section classified as Class 2 for cross-section design

**Compression check**

According to EN 1993-1-1 article 6.2.4 and formula (6.9)

A	1,8950e-03	m <sup>2</sup>
N <sub>c,Rd</sub>	445,32	kN
Unity check	0,62	

The member satisfies the section check.

....STABILITY CHECK:....

**Classification for member buckling design**

Decisive position for stability classification: 0,000 m

**Classification of Internal Compression parts**

According to EN 1993-1-1 Table 5.2 Sheet 1

Maximum width-to-thickness ratio	34,50
Class 1 Limit	33,00
Class 2 Limit	38,00
Class 3 Limit	42,00

=> Section classified as Class 2 for member buckling design

**Flexural Buckling check**

According to EN 1993-1-1 article 6.3.1.1 and formula (6.46)

Buckling parameters	yy	zz	
Sway type	sway	non-sway	
System length L	2,105	8,421	m
Buckling factor k	1,00	0,25	
Buckling length L <sub>cr</sub>	2,105	2,105	m
Critical Euler load N <sub>cr</sub>	2780,88	1489,92	kN

\*Student version\* \*Student version\* \*Student version\* \*Student version\* \*Student version\* \*Student version\*

Buckling parameters	yy	zz	
<i>*Student version* *Student version* *Student version* *Student version* *Student version* *Student</i>			
Slenderness Lambda	37,58	51,34	
Relative slenderness Lambda,rel	0,40	0,55	
Limit slenderness Lambda,rel,0	0,20	0,20	
Buckling curve	c	c	
Imperfection Alpha	0,49	0,49	
Reduction factor Chi	0,90	0,82	
Buckling resistance Nb,Rd	399,56	363,61	kN

Flexural Buckling verification		
<i>*Student version* *Student version* *Student version* *Student version* *Student v</i>		
Cross-section area A	1,8950e-03	m <sup>2</sup>
Buckling resistance Nb,Rd	363,61	kN
Unity check	0,76	-

#### Torsional(-Flexural) Buckling check

According to EN 1993-1-1 article 6.3.1.1 and formula (6.46)

**Note:** The cross-section concerns a RHS section which is not susceptible to Torsional(-Flexural) Buckling.

The member satisfies the stability check.

Student version



Buckling parameters	yy	zz	
<i>*Student version* *Student version* *Student version* *Student version* *Student version* *Student</i>			
Slenderness Lambda	54,65	109,30	
Relative slenderness Lambda,rel	0,58	1,16	
Limit slenderness Lambda,rel,0	0,20	0,20	
Buckling curve	c	c	
Imperfection Alpha	0,49	0,49	
Reduction factor Chi	0,80	0,45	
Buckling resistance Nb,Rd	343,46	194,75	kN

Flexural Buckling verification		
<i>*Student version* *Student version* *Student version* *Student version* *Student v</i>		
Cross-section area A	1,8360e-03	m <sup>2</sup>
Buckling resistance Nb,Rd	194,75	kN
Unity check	0,84	-

#### Torsional(-Flexural) Buckling check

According to EN 1993-1-1 article 6.3.1.1 and formula (6.46)

**Note:** The cross-section concerns a RHS section which is not susceptible to Torsional(-Flexural) Buckling.

The member satisfies the stability check.

Student version





Buckling parameters	yy	zz	
<i>*Student version* *Student version* *Student version* *Student version* *Student version* *Stude</i>			
Slenderness Lambda	81,27	81,27	
Relative slenderness Lambda,rel	0,87	0,87	
Limit slenderness Lambda,rel,0	0,20	0,20	
Buckling curve	c	c	
Imperfection Alpha	0,49	0,49	
Reduction factor Chi	0,62	0,62	
Buckling resistance Nb,Rd	148,18	148,18	kN

Flexural Buckling verification		
<i>*Student version* *Student version* *Student version* *Student version* *Student v</i>		
Cross-section area A	1,0150e-03	m <sup>2</sup>
Buckling resistance Nb,Rd	148,18	kN
Unity check	0,94	-

#### Torsional(-Flexural) Buckling check

According to EN 1993-1-1 article 6.3.1.1 and formula (6.46)

**Note:** The cross-section concerns a RHS section which is not susceptible to Torsional(-Flexural) Buckling.

The member satisfies the stability check.

Student version

Member B1	6,800 m	HEB320	S 235	GSN3	0,42 -
-----------	---------	--------	-------	------	--------

Partial safety factors	
Gamma M0 for resistance of cross-sections	1,00
Gamma M1 for resistance to instability	1,00
Gamma M2 for resistance of net sections	1,25

Material	
Yield strength $f_y$	235,0 MPa
Ultimate strength $f_u$	360,0 MPa
Fabrication	Rolled

....SECTION CHECK:....

The critical check is on position 6.800 m

Internal forces	Calculated	Unit
N,Ed	-11,24	kN
V <sub>y</sub> ,Ed	0,00	kN
V <sub>z</sub> ,Ed	66,85	kN
T,Ed	0,00	kNm
M <sub>y</sub> ,Ed	197,59	kNm
M <sub>z</sub> ,Ed	0,00	kNm

#### Classification for cross-section design

According to EN 1993-1-1 article 5.5.2

#### Classification of Internal Compression parts

According to EN 1993-1-1 Table 5.2 Sheet 1

Maximum width-to-thickness ratio	19,57
Class 1 Limit	70,46
Class 2 Limit	81,14
Class 3 Limit	121,28

=> Internal Compression parts Class 1

#### Classification of Outstand Flanges

According to EN 1993-1-1 Table 5.2 Sheet 2

Maximum width-to-thickness ratio	5,72
Class 1 Limit	9,00
Class 2 Limit	10,00
Class 3 Limit	13,77

=> Outstand Flanges Class 1

=> Section classified as Class 1 for cross-section design

#### Compression check

According to EN 1993-1-1 article 6.2.4 and formula (6.9)

A	1,6130e-02	m <sup>2</sup>
N <sub>c</sub> ,R <sub>d</sub>	3790,55	kN
Unity check	0,00	-

#### Bending moment check for M<sub>y</sub>

According to EN 1993-1-1 article 6.2.5 and formula (6.12),(6.13)

W <sub>pl,y</sub>	2,1490e-03	m <sup>3</sup>
M <sub>pl,y</sub> ,R <sub>d</sub>	505,01	kNm
Unity check	0,39	-

#### Shear check for V<sub>z</sub>

According to EN 1993-1-1 article 6.2.6 and formula (6.17)

E <sub>a</sub>	1,20	
A <sub>v</sub>	5,1727e-03	m <sup>2</sup>
V <sub>pl,z</sub> ,R <sub>d</sub>	701,82	kN
Unity check	0,10	-

#### Combined bending, axial force and shear force check

According to EN 1993-1-1 article 6.2.9.1 and formula (6.31)

Mpl,y,Rd	505,01	kNm
Unity check	0,39	-

**Note:** Since the shear forces are less than half the plastic shear resistances their effect on the moment resistances is neglected.

**Note:** Since the axial force satisfies both criteria (6.33) and (6.34) of EN 1993-1-1 article 6.2.9.1(4) its effect on the moment resistance about the y-y axis is neglected.

The member satisfies the section check.

....:STABILITY CHECK:....

**Classification for member buckling design**

Decisive position for stability classification: 0,378 m

**Classification of Internal Compression parts**

According to EN 1993-1-1 Table 5.2 Sheet 1

Maximum width-to-thickness ratio	19,57
Class 1 Limit	71,93
Class 2 Limit	82,83
Class 3 Limit	116,54

=> Internal Compression parts Class 1

**Classification of Outstand Flanges**

According to EN 1993-1-1 Table 5.2 Sheet 2

Maximum width-to-thickness ratio	5,72
Class 1 Limit	9,00
Class 2 Limit	10,00
Class 3 Limit	13,77

=> Outstand Flanges Class 1

=> Section classified as Class 1 for member buckling design

**Flexural Buckling check**

According to EN 1993-1-1 article 6.3.1.1 and formula (6.46)

Buckling parameters	yy	zz	
<small>*Student version* *Student version* *Student version* *Student version* *Student version* *Student version*</small>			
Sway type	sway	non-sway	
System length L	6,800	6,800	m
Buckling factor k	2,00	1,00	
Buckling length Lcr	13,616	6,800	m
Critical Euler load Ncr	3445,39	4141,20	kN
Slenderness Lambda	98,50	89,85	
Relative slenderness Lambda,rel	1,05	0,96	
Limit slenderness Lambda,rel,0	0,20	0,20	

**Note:** The slenderness or compression force is such that Flexural Buckling effects may be ignored according to EN 1993-1-1 article 6.3.1.2(4).

**Torsional(-Flexural) Buckling check**

According to EN 1993-1-1 article 6.3.1.1 and formula (6.46)

**Note:** For this I-section the Torsional(-Flexural) buckling resistance is higher than the resistance for Flexural buckling. Therefore Torsional(-Flexural) buckling is not printed on the output.

**Lateral Torsional Buckling check**

According to EN 1993-1-1 article 6.3.2.1 & 6.3.2.2 and formula (6.54)

LTB parameters		
<small>*Student version* *Student version* *Student version* *Student version* *Student version* *Student version*</small>		
Method for LTB curve	General case	
Cross-section plastic modulus Wpl,y	2,1490e-03	m <sup>3</sup>
Elastic critical moment Mcr	3030,72	kNm
Relative slenderness Lambda,rel,LT	0,41	
Limit slenderness Lambda,rel,LT,0	0,20	
LTB curve	a	
Imperfection Alpha,LT	0,21	
Reduction factor Chi,LT	0,95	
Design buckling resistance Mb,Rd	480,07	kNm
Unity check	0,41	-

Mcr parameters		
<small>*Student version* *Student version* *Student version* *Student version* *Student version* *Student version*</small>		
LTB length L	6,800	m
<small>*Student version* *Student version* *Student version* *Student version* *Student version* *Student version*</small>		

Mcr parameters		
<i>*Student version* *Student version* *Student version* *Student version* *Student ver</i>		
Influence of load position	no influence	
Correction factor k	1,00	
Correction factor kw	1,00	
LTB moment factor C1	2,84	
LTB moment factor C2	0,29	
LTB moment factor C3	1,00	
Shear center distance d,z	0	mm
Distance of load application z,g	0	mm
Mono-symmetry constant beta,y	0	mm
Mono-symmetry constant z,j	0	mm

**Note:** C parameters are determined according to ECCS 119 2006 / Galea 2002.

#### Bending and axial compression check

According to EN 1993-1-1 article 6.3.3 and formula (6.61),(6.62)

Bending and axial compression check parameters		
<i>*Student version* *Student version* *Student version* *Student version* *Student version* *Student version* *Student version* *S</i>		
Interaction method	alternative method 1	
Cross-section area A	1,6130e-02	m <sup>2</sup>
Cross-section plastic modulus Wpl,y	2,1490e-03	m <sup>3</sup>
Design compression force N,Ed	11,24	kN
Design bending moment (maximum) My,Ed	197,59	kNm
Design bending moment (maximum) Mz,Ed	0,00	kNm
Characteristic compression resistance N,Rk	3790,55	kN
Characteristic moment resistance My,Rk	505,01	kNm
Reduction factor Chi,y	1,00	
Reduction factor Chi,z	1,00	
Reduction factor Chi,LT	0,95	
Interaction factor k,y	1,00	
Interaction factor k,z	0,52	

Maximum moment My,Ed is derived from beam B1 position 6,800 m.

Maximum moment Mz,Ed is derived from beam B1 position 0,000 m.

Interaction method 1 parameters		
<i>*Student version* *Student version* *Student version* *Student version* *Student version* *Student version* *Student version* *S</i>		
Critical Euler load N <sub>cr,y</sub>	3445,39	kN
Critical Euler load N <sub>cr,z</sub>	4141,20	kN
Elastic critical load N <sub>cr,T</sub>	11054,42	kN
Cross-section plastic modulus Wpl,y	2,1490e-03	m <sup>3</sup>
Cross-section elastic modulus Wel,y	1,9260e-03	m <sup>3</sup>
Cross-section plastic modulus Wpl,z	9,3910e-04	m <sup>3</sup>
Cross-section elastic modulus Wel,z	6,1590e-04	m <sup>3</sup>
Second moment of area Iy	3,0820e-04	m <sup>4</sup>
Second moment of area Iz	9,2390e-05	m <sup>4</sup>
Torsional constant It	2,2510e-06	m <sup>4</sup>
Method for equivalent moment factor C <sub>m,y,0</sub>	Table A.2 Line 2 (General)	
Design bending moment (maximum) My,Ed	197,59	kNm
Maximum relative deflection delta,z	-4,3	mm
Equivalent moment factor C <sub>m,y,0</sub>	1,00	
Factor mu,y	1,00	
Factor mu,z	1,00	
Factor epsilon,y	147,22	
Factor a <sub>LT</sub>	0,99	
Critical moment for uniform bending M <sub>cr,0</sub>	1066,26	kNm
Relative slenderness Lambda <sub>rel,0</sub>	0,69	
Limit relative slenderness Lambda <sub>rel,0,lim</sub>	0,34	
Equivalent moment factor C <sub>m,y</sub>	1,00	
Equivalent moment factor C <sub>m,LT</sub>	1,00	
Factor b <sub>LT</sub>	0,00	
Factor d <sub>LT</sub>	0,00	
Factor w <sub>y</sub>	1,12	
Factor w <sub>z</sub>	1,50	
Factor n <sub>pl</sub>	0,00	
Maximum relative slenderness Lambda <sub>rel,max</sub>	1,05	
Factor C <sub>y,y</sub>	1,00	
Factor C <sub>z,y</sub>	1,00	

Unity check (6.61) = 0,00 + 0,41 + 0,00 = 0,42 -

Unity check (6.62) = 0,00 + 0,21 + 0,00 = 0,22 -

### Shear Buckling check

According to EN 1993-1-5 article 5 & 7.1 and formula (5.10) & (7.1)

Shear Buckling parameters		
---------------------------	--	--

*\*Student version\* \*Student version\* \*Student version\* \*Student version\* \*Stude*

Buckling field length a	6,800	m
Web	unstiffened	
Web height hw	279	mm
Web thickness t	12	mm
Material coefficient epsilon	1,00	
Shear correction factor Eta	1,20	

Shear Buckling verification	
-----------------------------	--

*\*Student version\* \*Student version\* \*Student version\* \*Stua*

Web slenderness hw/t	24,26
Web slenderness limit	60,00

**Note:** The web slenderness is such that Shear Buckling effects may be ignored according to EN 1993-1-5 article 5.1(2).

The member satisfies the stability check.

Student version

# DETALJ SPOJA M 1:10

## DETALJ "D" VLAČNI NASTAVAK REŠETKE GORNJEG POJASA

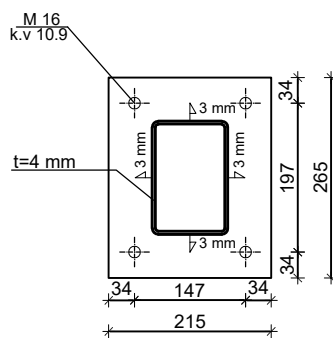
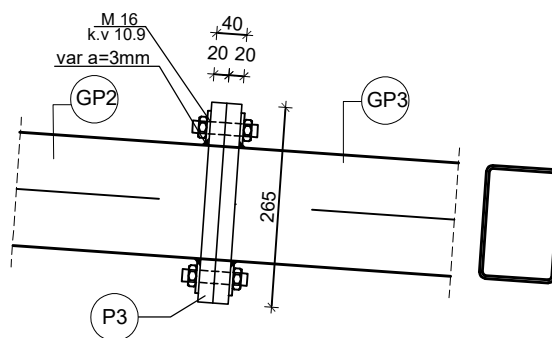

FAK. GRAĐEVINARSTVA, ARHITEKTURE I GEO.	
METALNE KONSTRUKCIJE	
DETALJ SPOJA-"D"	
AK.GOD. 2015/2016	M 1:10
STUDENT:	Petar Kurt

# DETALJ SPOJA M 1:10

DETALJ "C"  
VLAČNI NASTAVAK REŠETKE  
DONJEG POJASA

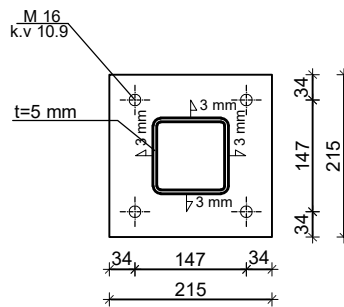
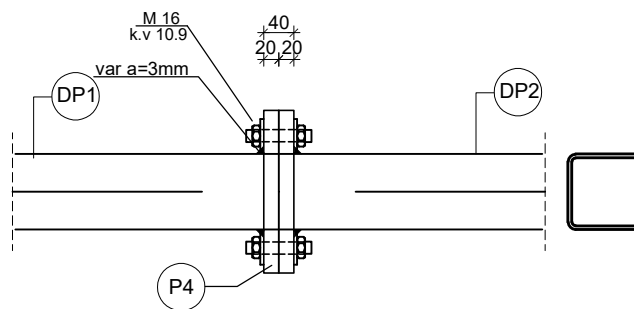

FAK. GRAĐEVINARSTVA, ARHITEKTURE I GEO.	
METALNE KONSTRUKCIJE	
DETALJ SPOJA-"C"	
AK.GOD. 2015/2016	M 1:10
STUDENT:	Petar Kurt



# DETALJ SPOJA M 1:10

## DETALJ "A" ZGLOBNI SPOJ STUPA S REŠETKOM

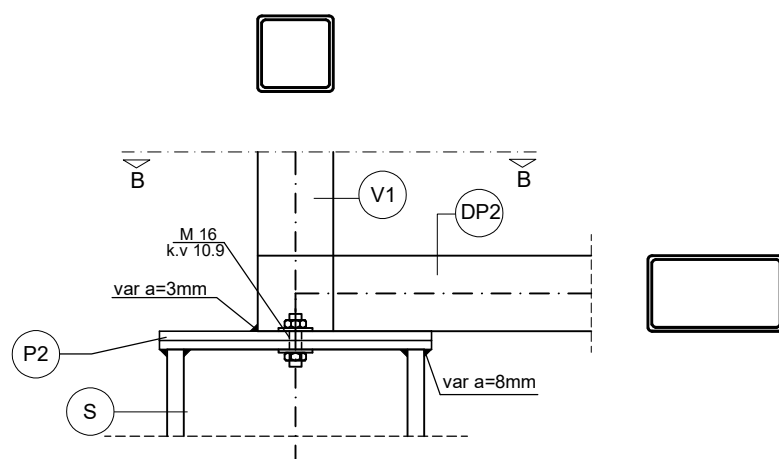

Presjek B-B

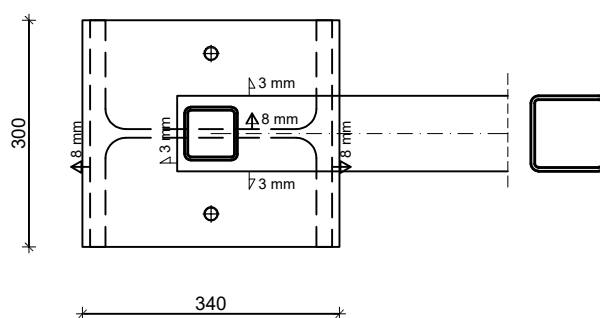

FAK. GRAĐEVINARSTVA, ARHITEKTURE I GEO.	
METALNE KONSTRUKCIJE	
DETALJ SPOJA "A"	
AK.GOD. 2015/2016	M 1:10
STUDENT:	Petar Kurt

# DETALJ SPOJA M 1:10

## DETALJ "B" UPETI SPOJ STUPA S TEMELJEM

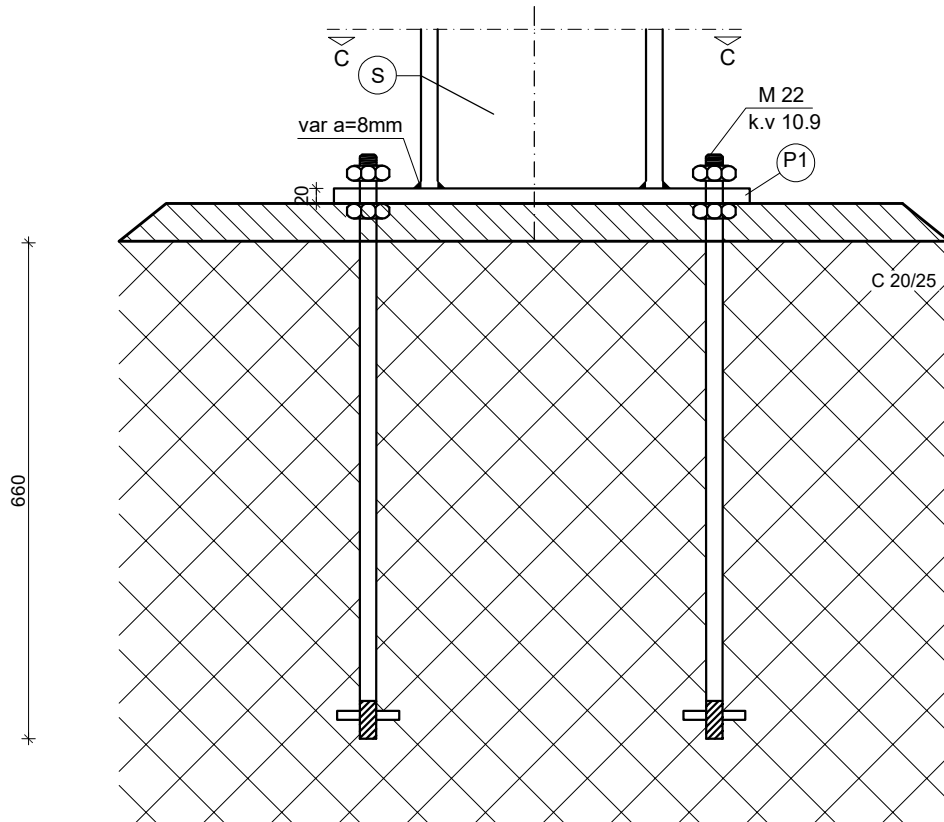

Presjek C-C

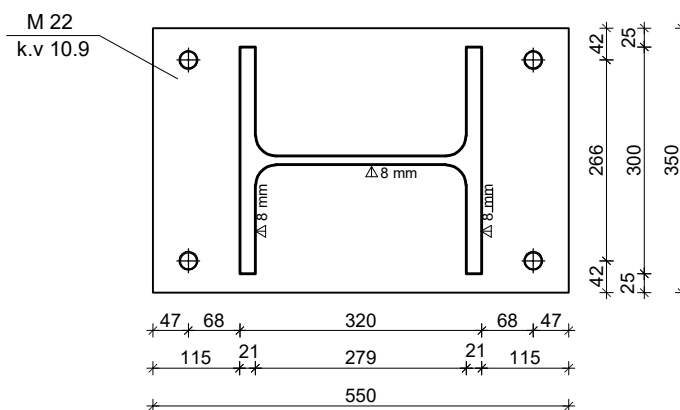

FAK. GRAĐEVINARSTVA, ARHITEKTURE I GEO.	
METALNE KONSTRUKCIJE	
DETALJ SPOJA-"B"	
AK.GOD. 2015/2016	M 1:10
STUDENT:	Petar Kurt

## 10. ISKAZ KOLIČINE ČELIKA

TABLICA PREDMJERA MATERIJALA ZA JEDAN OKVIR (DUŽINSKI ELEMENTI)					
POZICIJA	PROFIL	DUŽINA (mm)	KOMADA	JED. TEŽINA (kg/m)	UKUPNA TEŽINA (kg)
Stup S	HEB 320	6700	2	127,00	1701,80
Donji pojas DP1	100x100x5	12000	1	14,40	172,80
Donji pojas DP2	100x100x5	4850	1	14,40	69,84
Gornji pojas GP1	150x100x4	8455	1	14,90	125,97
Gornji pojas GP2	150x100x4	6012	1	14,90	89,58
Gornji pojas GP3	150x100x4	4850	1	14,90	72,27
Vertikala V1	70x70x4	409	2	8,00	6,54
Vertikala V2	70x70x4	556	2	8,00	8,90
Vertikala V3	70x70x4	703	2	8,00	11,25
Vertikala V4	70x70x4	850	2	8,00	13,60
Vertikala V5	70x70x4	993	1	8,00	7,94
Dijagonala D1	70x70x4	1968	2	8,00	31,48
Dijagonala D2	70x70x4	2039	2	8,00	32,64
Dijagonala D3	70x70x4	2104	2	8,00	33,66
Dijagonala D4	70x70x4	2179	2	8,00	34,86
TABLICA PREDMJERA MATERIJALA ZA JEDAN OKVIR (PLOČICE)					
POZICIJA	DIMENZIJE (mm)	DUŽINA (mm)	KOMADA	JED. TEŽINA (kg/m <sup>3</sup> )	UKUPNA TEŽINA (kg)
Pločica P1	550x350x20	-	2	7850	60,45
Pločica P2	340x300x12	-	4	7850	38,43
Pločica P3	265x215x20	-	2	7850	17,90
Pločica P4	215x215x20	-	2	7850	14,51
				UKUPNO (kg)	2674,00
				+ 5,0 % spojna sredstva	2807,70
TABLICA PREDMJERA MATERIJALA ZA SEKUNDARNU KONSTRUKCIJU					
POZICIJA	PROFIL	DUŽINA (mm)	KOMADA	JED. MASA (kg/m)	UKUPNA MASA (kg)
KP	IPE 180	5700	70	18,8	7501,20
BP	IPE 180	5700	56	18,8	6000,96
S1	φ20	56640	2	2,46	278,66
S2	φ22	36800	4	2,98	438,65
				Ukupno (kg)	14219,47

Ukupna teжина konstrukcije hale (bez fasadnih i krovnih panela):

$$G=2807,70 \cdot 8 + 14219,47 = 36681,07 \text{ kg}$$

Težina po kvadratu bruto tlocrta:

$$G=36681,07 / (16,8 \cdot 39,9) = 54,72 \text{ kg/m}^2$$