

Marble Wall Decorations from the Imperial Mausoleum (4th C.) and the Basilica of San Lorenzo (5th C.) in Milan: an Update on Colored Marbles in Late Antique Milan

Neri, Elisabetta; Bugini, Roberto; Gazzoli, Silvia

Source / Izvornik: **ASMOSIA XI, Interdisciplinary Studies on Ancient Stone, Proceedings of the XI International Conference of ASMOSIA, 2018, 79 - 87**

Conference paper / Rad u zborniku

Publication status / Verzija rada: **Published version / Objavljena verzija rada (izdavačev PDF)**

<https://doi.org/10.31534/XI.asmosia.2015/01.05>

Permanent link / Trajna poveznica: <https://um.nsk.hr/um:nbn:hr:123:678319>

Rights / Prava: [In copyright](#) / [Zaštićeno autorskim pravom.](#)

Download date / Datum preuzimanja: **2025-01-14**

Repository / Repozitorij:



[FCEAG Repository - Repository of the Faculty of Civil Engineering, Architecture and Geodesy, University of Split](#)





ASMOSIA XI

Interdisciplinary Studies on Ancient Stone

PROCEEDINGS

of the XI ASMOSIA Conference, Split 2015

Edited by Daniela Matetić Poljak and Katja Marasović



Interdisciplinary Studies on Ancient Stone
Proceedings of the XI ASMOSIA Conference (Split 2015)

Publishers:

ARTS ACADEMY IN SPLIT
UNIVERSITY OF SPLIT

and

UNIVERSITY OF SPLIT
FACULTY OF CIVIL ENGINEERING,
ARCHITECTURE AND GEODESY

Technical editor:
Kate Bošković

English language editor:
Graham McMaster

Computer pre-press:
Nikola Križanac

Cover design:
Mladen Čulić

Cover page:

Sigma shaped mensa of pavonazzetto marble from Diocletian's palace in Split

ISBN 978-953-6617-49-4 (Arts Academy in Split)

ISBN 978-953-6116-75-1 (Faculty of Civil Engineering, Architecture and Geodesy)

e-ISBN 978-953-6617-51-7 (Arts Academy in Split)

e-ISBN 978-953-6116-79-9 (Faculty of Civil Engineering, Architecture and Geodesy)

CIP available at the digital catalogue of the University Library in Split, no 170529005

Association for the Study of Marble & Other Stones in Antiquity

ASMOSIA XI

Interdisciplinary Studies of Ancient Stone

Proceedings of the Eleventh International Conference of ASMOSIA,
Split, 18–22 May 2015

Edited by
Daniela Matetić Poljak
Katja Marasović



Split, 2018

Nota bene

All papers are subjected to an international review.

The quality of the images relies on the quality of the originals provided by the authors.

CONTENT

PRESENTATION	15
NECROLOGY: NORMAN HERZ (1923-2013) by Susan Kane	17
1. APPLICATIONS TO SPECIFIC ARCHEOLOGICAL QUESTIONS – USE OF MARBLE	
Hermaphrodites and Sleeping or Reclining Maenads: Production Centres and Quarry Marks <i>Patrizio Pensabene</i>	25
First Remarks about the Pavement of the Newly Discovered Mithraeum of the Colored Marbles at Ostia and New Investigations on Roman and Late Roman White and Colored Marbles from Insula IV, IX <i>Massimiliano David, Stefano Succi and Marcello Turci</i>	33
Alabaster. Quarrying and Trade in the Roman World: Evidence from Pompeii and Herculaneum <i>Simon J. Barker and Simona Perna</i>	45
Recent Work on the Stone at the Villa Arianna and the Villa San Marco (Castellammare di Stabia) and Their Context within the Vesuvian Area <i>Simon J. Barker and J. Clayton Fant</i>	65
Marble Wall Decorations from the Imperial Mausoleum (4 th C.) and the Basilica of San Lorenzo (5 th C.) in Milan: an Update on Colored Marbles in Late Antique Milan <i>Elisabetta Neri, Roberto Bugini and Silvia Gazzoli</i>	79
Sarcophagus Lids Sawn from their Chests <i>Dorothy H. Abramitis and John J. Herrmann</i>	89
The Re-Use of Monolithic Columns in the Invention and Persistence of Roman Architecture <i>Peter D. De Staebler</i>	95
The Trade in Small-Size Statues in the Roman Mediterranean: a Case Study from Alexandria <i>Patrizio Pensabene and Eleonora Gasparini</i>	101
The Marble Dedication of Komon, Son of Asklepiades, from Egypt: Material, Provenance, and Reinforcement of Meaning <i>Patricia A. Butz</i>	109
Multiple Reuse of Imported Marble Pedestals at Caesarea Maritima in Israel <i>Barbara Burrell</i>	117
Iasos and Iasian Marble between the Late Antique and Early Byzantine Eras <i>Diego Peirano</i>	123

Thassos, Known Inscriptions with New Data <i>Tony Kozelj and Manuela Wurch-Kozelj</i>	131
The Value of Marble in Roman <i>Hispalis</i> : Contextual, Typological and Lithological Analysis of an Assemblage of Large Architectural Elements Recovered at N° 17 Goyeneta Street (Seville, Spain) <i>Ruth Taylor, Oliva Rodríguez, Esther Ontiveros, María Luisa Loza, José Beltrán and Araceli Rodríguez</i>	143
<i>Giallo Antico</i> in Context. Distribution, Use and Commercial Actors According to New Stratigraphic Data from the Western Mediterranean (2 nd C. Bc – Late 1 st C. Ad) <i>Stefan Ardeleanu</i>	155
<i>Amethystus</i> : Ancient Properties and Iconographic Selection <i>Luigi Pedroni</i>	167
2. PROVENANCE IDENTIFICATION I: (MARBLE)	
Unraveling the Carrara – Göktepe Entanglement <i>Walter Prochaska, Donato Attanasio and Matthias Bruno</i>	175
The Marble of Roman Imperial Portraits <i>Donato Attanasio, Matthias Bruno, Walter Prochaska and Ali Bahadır Yavuz</i>	185
Tracing Alabaster (Gypsum or Anhydrite) Artwork Using Trace Element Analysis and a Multi-Isotope Approach (Sr, S, O) <i>Lise Leroux, Wolfram Kloppmann, Philippe Bromblet, Catherine Guerrot, Anthony H. Cooper, Pierre-Yves Le Pogam, Dominique Vingtain and Noel Worley</i>	195
Roman Monolithic Fountains and Thasian Marble <i>Annewies van den Hoek, Donato Attanasio and John J. Herrmann</i>	207
Archaeometric Analysis of the Alabaster Thresholds of Villa A, Oplontis (Torre Annunziata, Italy) and New Sr and Pb Isotopic Data for <i>Alabastro Ghiaccione del Circeo</i> <i>Simon J. Barker, Simona Perna, J. Clayton Fant, Lorenzo Lazzarini and Igor M. Villa</i>	215
Roman Villas of Lake Garda and the Occurrence of Coloured Marbles in the Western Part of “Regio X Venetia et Histria” (Northern Italy) <i>Roberto Bugini, Luisa Folli and Elisabetta Roffia</i>	231
Calcitic Marble from Thasos in the North Adriatic Basin: Ravenna, Aquileia, and Milan <i>John J. Herrmann, Robert H. Tykot and Annewies van den Hoek</i>	239
Characterisation of White Marble Objects from the Temple of Apollo and the House of Augustus (Palatine Hill, Rome) <i>Francesca Giustini, Mauro Brilli, Enrico Gallochio and Patrizio Pensabene</i>	247
Study and Archeometric Analysis of the Marble Elements Found in the Roman Theater at Aeclanum (Mirabella Eclano, Avellino - Italy) <i>Antonio Mesisca, Lorenzo Lazzarini, Stefano Cancelliere and Monica Salvadori</i>	255

Two Imperial Monuments in Puteoli: Use of Proconnesian Marble in the Domitianic and Trajanic Periods in Campania <i>Irene Bald Romano, Hans Rupprecht Goette, Donato Attanasio and Walter Prochaska</i>	267
Coloured Marbles in the Neapolitan Pavements (16 th And 17 th Centuries): the Church of <i>Santi Severino e Sossio</i> <i>Roberto Bugini, Luisa Folli and Martino Solito</i>	275
Roman and Early Byzantine Sarcophagi of Calcitic Marble from Thasos in Italy: Ostia and Siracusa <i>Donato Attanasio, John J. Herrmann, Robert H. Tykot and Annewies van den Hoek</i>	281
Revisiting the Origin and Destination of the Late Antique Marzamemi 'Church Wreck' Cargo <i>Justin Leidwanger, Scott H. Pike and Andrew Donnelly</i>	291
The Marbles of the Sculptures of Felix Romuliana in Serbia <i>Walter Prochaska and Maja Živić</i>	301
Calcitic Marble from Thasos and Proconnesos in Nea Anchialos (Thessaly) and Thessaloniki (Macedonia) <i>Vincent Barbin, John J. Herrmann, Aristotle Mentzos and Annewies van den Hoek</i>	311
Architectural Decoration of the Imperial Agora's Porticoes at Iasos <i>Fulvia Bianchi, Donato Attanasio and Walter Prochaska</i>	321
The Winged Victory of Samothrace - New Data on the Different Marbles Used for the Monument from the Sanctuary of the Great Gods <i>Annie Blanc, Philippe Blanc and Ludovic Laugier</i>	331
Polychrome Marbles from the Theatre of the Sanctuary of Apollo Pythios in Gortyna (Crete) <i>Jacopo Bonetto, Nicolò Mareso and Michele Bueno</i>	337
Paul the Silentary, Hagia Sophia, Onyx, Lydia, and Breccia Corallina <i>John J. Herrmann and Annewies van den Hoek</i>	345
Incrustations from Colonia Ulpia Traiana (Near Modern Xanten, Germany) <i>Vilma Ruppinić and Ulrich Schüssler</i>	351
Stone Objects from Vindobona (Austria) – Petrological Characterization and Provenance of Local Stone in a Historico-Economical Setting <i>Andreas Rohatsch, Michaela Kronberger, Sophie Insulander, Martin Mosser and Barbara Hodits</i>	363
Marbles Discovered on the Site of the Forum of Vaison-la-Romaine (Vaucluse, France): Preliminary Results <i>Elsa Roux, Jean-Marc Mignon, Philippe Blanc and Annie Blanc</i>	373
Updated Characterisation of White Saint-Béat Marble. Discrimination Parameters from Classical Marbles <i>Hernando Royo Plumed, Pilar Lapeunte, José Antonio Cuchí, Mauro Brillì and Marie-Claire Savin</i>	379

Grey and Greyish Banded Marbles from the Estremoz Anticline in Lusitania <i>Pilar Lapuente, Trinidad Nogales-Basarrate, Hernando Royo Plumed, Mauro Brilli and Marie-Claire Savin</i>	391
New Data on Spanish Marbles: the Case of <i>Gallaecia</i> (NW Spain) <i>Anna Gutiérrez García-M., Hernando Royo Plumed and Silvia González Soutelo</i>	401
A New Roman Imperial Relief Said to Be from Southern Spain: Problems of Style, Iconography, and Marble Type in Determining Provenance <i>John Pollini, Pilar Lapuente, Trinidad Nogales-Basarrate and Jerry Podany</i>	413
Reuse of the <i>Marmora</i> from the Late Roman Palatial Building at Carranque (Toledo, Spain) in the Visigothic Necropolis <i>Virginia García-Entero, Anna Gutiérrez García-M. and Sergio Vidal Álvarez</i>	427
Imperial Porphyry in Roman Britain <i>David F. Williams</i>	435
Recycling of Marble: Apollonia/Sozousa/Arsuf (Israel) as a Case Study <i>Moshe Fischer, Dimitris Tambakopoulos and Yannis Maniatis</i>	443
Thasian Connections Overseas: Sculpture in the Cyrene Museum (Libya) Made of Dolomitic Marble from Thasos <i>John J. Herrmann and Donato Attanasio</i>	457
Marble on Rome's Southwestern Frontier: Thamugadi and Lambaesis <i>Robert H. Tykot, Ouahiba Bouzidi, John J. Herrmann and Annewies van den Hoek</i>	467
Marble and Sculpture at Lepcis Magna (Tripolitania, Libya): a Preliminary Study Concerning Origin and Workshops <i>Luisa Musso, Laura Buccino, Matthias Bruno, Donato Attanasio and Walter Prochaska</i>	481
The Pentelic Marble in the Carnegie Museum of Art Hall of Sculpture, Pittsburgh, Pennsylvania <i>Albert D. Kollar</i>	491
Analysis of Classical Marble Sculptures in the Michael C. Carlos Museum, Emory University, Atlanta <i>Robert H. Tykot, John J. Herrmann, Renée Stein, Jasper Gaunt, Susan Blevins and Anne R. Skinner</i>	501
3. PROVENANCE IDENTIFICATION II: (OTHER STONES)	
Aphrodisias and the Regional Marble Trade. The <i>Scaenae Frons</i> of the Theatre at Nysa <i>Natalia Toma</i>	513
The Stones of Felix Romuliana (Gamzigrad, Serbia) <i>Bojan Djurić, Divna Jovanović, Stefan Pop Lazić and Walter Prochaska</i>	523
Aspects of Characterisation of Stone Monuments from Southern Pannonia <i>Branka Migotti</i>	537

The Budakalász Travertine Production <i>Bojan Djurić, Sándor Kele and Igor Rižnar</i>	545
Stone Monuments from Carnuntum and Surrounding Areas (Austria) – Petrological Characterization and Quarry Location in a Historical Context <i>Gabrielle Kremer, Isabella Kitz, Beatrix Moshhammer, Maria Heinrich and Erich Draganits</i>	557
Espejón Limestone and Conglomerate (Soria, Spain): Archaeometric Characterization, Quarrying and Use in Roman Times <i>Virginia García-Entero, Anna Gutiérrez García-M, Sergio Vidal Álvarez, María J. Peréx Agorreta and Eva Zarco Martínez</i>	567
The Use of Alcover Stone in Roman Times (<i>Tarraco, Hispania Citerior</i>). Contributions to the <i>Officina Lapidaria Tarraconensis</i> <i>Diana Gorostidi Pi, Jordi López Vilar and Anna Gutiérrez García-M.</i>	577
4. ADVANCES IN PROVENANCE TECHNIQUES, METHODOLOGIES AND DATABASES	
Grainautline – a Supervised Grain Boundary Extraction Tool Supported by Image Processing and Pattern Recognition <i>Kristóf Csorba, Lilla Barancsuk, Balázs Székely and Judit Zöldföldi</i>	587
A Database and GIS Project about Quarrying, Circulation and Use of Stone During the Roman Age in <i>Regio X - Venetia et Histria</i> . The Case Study of the Euganean Trachyte <i>Caterine Previato and Arturo Zara</i>	597
5. QUARRIES AND GEOLOGY	
The Distribution of Troad Granite Columns as Evidence for Reconstructing the Management of Their Production <i>Patrizio Pensabene, Javier Á. Domingo and Isabel Rodà</i>	613
Ancient Quarries and Stonemasonry in Northern Choria Considiana <i>Hale Güney</i>	621
Polychromy in Larisaeon Quarries and its Relation to Architectural Conception <i>Gizem Mater and Ertunç Denктаş</i>	633
Euromos of Caria: the Origin of an Hitherto Unknown Grey Veined Stepped Marble of Roman Antiquity <i>Matthias Bruno, Donato Attanasio, Walter Prochaska and Ali Bahadır Yavuz</i>	639
Unknown Painted Quarry Inscriptions from Bacakale at <i>Docimium</i> (Turkey) <i>Matthias Bruno</i>	651
The Green Schist Marble Stone of Jebel El Hairech (North West of Tunisia): a Multi-Analytical Approach and its Uses in Antiquity <i>Ameur Younès, Mohamed Gaied and Wissem Gallala</i>	659
Building Materials and the Ancient Quarries at <i>Thamugadi</i> (East of Algeria), Case Study: Sandstone and Limestone <i>Younès Rezkallah and Ramdane Marmi</i>	673

The Local Quarries of the Ancient Roman City of <i>Valeria</i> (Cuenca, Spain) <i>Javier Atienza Fuente</i>	683
The Stone and Ancient Quarries of Montjuïc Mountain (Barcelona, Spain) <i>Aureli Álvarez</i>	693
<i>Notae Lapidinarum</i> : Preliminary Considerations about the Quarry Marks from the Provincial Forum of <i>Tarraco</i> <i>Maria Serena Vinci</i>	699
The Different Steps of the Rough-Hewing on a Monumental Sculpture at the Greek Archaic Period: the Unfinished Kouros of Thasos <i>Danièle Braunstein</i>	711
A Review of Copying Techniques in Greco-Roman Sculpture <i>Séverine Moureaud</i>	717
Labour Forces at Imperial Quarries <i>Ben Russell</i>	733
Social Position of Craftsmen inside the Stone and Marble Processing Trades in the Light of Diocletian's Edict on Prices <i>Krešimir Bosnić and Branko Matulić</i>	741
6. STONE PROPERTIES, WEATHERING EFFECTS AND RESTORATION, AS RELATED TO DIAGNOSIS PROBLEMS, MATCHING OF STONE FRAGMENTS AND AUTHENTICITY	
Methods of Consolidation and Protection of Pentelic Marble <i>Maria Apostolopoulou, Elissavet Drakopoulou, Maria Karoglou and Asterios Bakolas</i>	749
7. PIGMENTS AND PAINTINGS ON MARBLE	
Painting and Sculpture Conservation in Two Gallo-Roman Temples in Picardy (France): Champlieu and Pont-Sainte-Maxence <i>Véronique Brunet-Gaston and Christophe Gaston</i>	763
The Use of Colour on Roman Marble Sarcophagi <i>Eliana Siotto</i>	773
New Evidence for Ancient Gilding and Historic Restorations on a Portrait of Antinous in the San Antonio Museum of Art <i>Jessica Powers, Mark Abbe, Michelle Bushey and Scott H. Pike</i>	783
Schists and Pigments from Ancient Swat (Khyber Pukhtunkhwa, Pakistan) <i>Francesco Mariottini, Gianluca Vignaroli, Maurizio Mariottini and Mauro Roma</i>	793
8. SPECIAL THEME SESSION: „THE USE OF MARBLE AND LIMESTONE IN THE ADRIATIC BASIN IN ANTIQUITY”	
Marble Sarcophagi of Roman Dalmatia Material – Provenance – Workmanship <i>Guntram Koch</i>	809

Funerary Monuments and Quarry Management in Middle Dalmatia <i>Nenad Cambi</i>	827
Marble Revetments of Diocletian's Palace <i>Katja Marasović and Vinka Marinković</i>	839
The Use of Limestones as Construction Materials for the Mosaics of Diocletian's Palace <i>Branko Matulić, Domagoj Mudronja and Krešimir Bosnić</i>	855
Restoration of the Peristyle of Diocletian's Palace in Split <i>Goran Nikšić</i>	863
Marble Slabs Used at the Archaeological Site of Sorna near Poreč Istria – Croatia <i>Đeni Gobić-Bravar</i>	871
Ancient Marbles from the Villa in Verige Bay, Brijuni Island, Croatia <i>Mira Pavletić and Đeni Gobić-Bravar</i>	879
Notes on Early Christian Ambos and Altars in the Light of some Fragments from the Islands of Pag and Rab <i>Mirja Jarak</i>	887
The Marbles in the Chapel of the Blessed John of Trogir in the Cathedral of St. Lawrence at Trogir <i>Đeni Gobić-Bravar and Daniela Matetić Poljak</i>	899
The Use of Limestone in the Roman Province of Dalmatia <i>Edisa Lozić and Igor Rižnar</i>	915
The Extraction and Use of Limestone in Istria in Antiquity <i>Klara Buršić-Matijašić and Robert Matijašić</i>	925
Aurisina Limestone in the Roman Age: from Karst Quarries to the Cities of the Adriatic Basin <i>Caterina Previato</i>	933
The Remains of Infrastructural Facilities of the Ancient Quarries on Zadar Islands (Croatia) <i>Mate Parica</i>	941
The Impact of Local Geomorphological and Geological Features of the Area for the Construction of the Burnum Amphitheatre <i>Miroslav Glavičić and Uroš Stepišnik</i>	951
Roman Quarry Klis Kosa near Salona <i>Ivan Alduk</i>	957
Marmore Lavdata Brattia <i>Miona Miliša and Vinka Marinković</i>	963
Quarries of the Lumbarda Archipelago <i>Ivka Lipanović and Vinka Marinković</i>	979

Island of Korčula – Importer and Exporter of Stone in Antiquity <i>Mate Parica and Igor Borzić</i>	985
Faux Marbling Motifs in Early Christian Frescoes in Central and South Dalmatia: Preliminary Report <i>Tonči Borovac, Antonija Gluhan and Nikola Radošević</i>	995
INDEX OF AUTHORS	1009

MARBLE WALL DECORATIONS FROM THE IMPERIAL MAUSOLEUM (4TH C.) AND THE BASILICA OF SAN LORENZO (5TH C.) IN MILAN: AN UPDATE ON COLORED MARBLES IN LATE ANTIQUE MILAN

Elisabetta Neri^{1,3}, Roberto Bugini² and Silvia Gazzoli³

¹ Université Paris-Sorbonne, Paris, France/Università Cattolica del Sacro Cuore, Milan, Italy (Elisabetta.neri@unicatt.it)

² CNR-ICVBC, Ist. Conservazione Beni Culturali, Milan, Italy (bugini@icvbc.cnr.it)

³ Università Cattolica del Sacro Cuore, Milan, Italy (silviag.gazzoli@gmail.com)

Abstract

The unpublished remains of marble *crustae* from late Antique Milan are here presented. They covered the walls of two buildings of imperial commission in Milan: the Imperial Mausoleum and the Basilica of San Lorenzo (4th–5th C. AD). The comparison between the two buildings allows the formulation of hypotheses on the supply, reuse and use of this type of decoration for two buildings that were designed less than one century apart, but in two definitely different political contexts.

Keywords

Opus sectile, Late Antique, colored marbles, Milan, wall decoration

This paper aims at presenting the unpublished remains of the marble *crustae* from the walls of two Late Antique buildings in Milan, both under the emperor's patronage: the Imperial Mausoleum and the Basilica of San Lorenzo. The former was built in the mid-4th c.¹, the second completed by the mid-5th c.²

A lithological examination of the remains and the observation of the manufacturing marks on the slabs allow the identification of the lithotypes used in the two sites, a review of the cutting techniques, and the acquisition of information on the reuse of the materials and on the customer's means. By comparing the two sites, some considerations can be made on the supply, the reuse and the diffusion of this type of decoration in Late Antique Milan.

E.N.–R.B.

1. The Imperial mausoleum

Context

The Imperial Mausoleum, located in the southwestern suburbium of Milan, was demolished in the 16th c. to build the present-day church of San Vittore al Corpo. A small portion of the mausoleum was excavated by Mario Mirabella Roberti in 1972–73. The building was located in one of the first necropoleis to be Christianized (since the first half of the 4th c.). It had an octagonal plan, alternating circular and rectangular niches, and its elevation probably included upper galleries, as suggested by comparing it with an anonymous depiction (at the Staatsgalerie in Stuttgart) and with the later example of Sant'Aquilino. It was erected in the mid-4th c., according to a recent thermoluminescence analysis of the foundation's bricks³. Of its rich decoration, only the imprint of the floor *opus sectile* remains on site, with black and white alternating triangles and hexagons, a common pattern in 4th c. Northern Italy.

Short before the demolition of the mausoleum, Jacopo Filippo Besta (15th c.) described its architecture, organized on two floors, with corridors and an upper deambulatory, as “as round above as it is below”, adding that it was “all finished with mosaic”. Bonaventura Castiglioni (+1553) describes the ancient appearance of the building, focusing his attention on the parietal *sectilia*: “some works in the finest marbles of different colours, tessellated, that is like mosaics; stone slabs sawn with various friezes, composed with vases, flowers and animals, which have now disappeared, the walls whitewashed and the magnificent works withdrawn”⁴. The

1 SANNAZARO 2015; LUSUARDI SIENA, NERI 2013.

2 NERI, LUSUARDI SIENA, GREPPI 2015.

3 SANNAZARO 2015.

4 Bonaventura Castiglione, cod Ambr. N. 153, f. 30v.: ‘in cotesto tempio vi erano anche alcuni lavori di marmi finissimi di diversi colori tassillati, ossia alla mosaica, tavole di pietra segate con frisi varii, componuti di vasi

author testifies that the figurative marble inlays had been removed and replaced with a white wall.

While neglected until the present day, some elements of this decoration were unearthed by the excavations in the 1970s: marble *crustae*, glass tesserae, painting and stucco fragments. The *crustae* are described here in particular: by rereading the excavation journals, we could identify the locations of their findings, which occurred while removing the layers of collapse of the building (between April and May 1973).

E.N.

The *crustae*

The preserved *crustae* represent less than 1% of the surface that was probably decorated in the excavated portion of the mausoleum. When the building was demolished, the decoration had already been largely removed; some fragments of medieval and late medieval frescoes, also found in the layers of collapse, testify that some portions of the wall – most likely where the early Christian decoration was lacunary – were integrated by painting.

The *crustae* are predominantly made of imported marble, with the exception of “nero delle Prealpi” and Palombino limestone; moreover, precious lithotypes – mentioned as the most expensive in the *Edictum de pretiis* – predominate: Imperial porphyry (Egypt), Spartan basalt or “green porphyry” (*lapis lacedaemonius*, Greece), “Pavoazzetto” or Phrygian marble (Turkey), “giallo antico” or Numidian marble (*marmor numidicum*, Tunisia), Egyptian alabaster marble, and fine-grained white marbles. These are associated with “rosso antico” or Tainaron marble (*marmor taenarium*, Greece), “fior di pesco” (*marmor chalcidicum*, Greece), “cipollino” from Euboea (*marmor carystium*, Greece) and “africano” (*marmor luculleum*, Turkey)⁵.

They are found in the following percentages:⁶ Imperial porphyry 9.2%, green porphyry 7.9%, pavoazzetto 5.3%, giallo antico 8.1%, alabaster 0.3%, fine-grained white marbles 7.2%, rosso antico 2/6%, Eretria red 7.4%, fior di pesco 6.3%, cipollino 10.1%, africano 5.8%, Nero delle Prealpi 7.4%, Palombino 22.2%.

di fiori e di animali, or venuti al meno, e datovi il bianco levate l'opere magnifiche.

5 On the value of the different lithotypes based on the *Edictum*, see *Marmi antichi* 1989 and *I marmi colorati della Roma imperiale* 2006. For specific considerations on the prices see GNOLI 1988.

6 The quantitative data are furnished in weight of material. The percentages are similar to these of number of *crustae* per material.

The most frequent patterns that can be identified are simple rectilinear bands and border listels, kyma moulds with an oblique side, together with several listels with semicircular sections and flat slabs, mainly in pavoazzetto and africano marble. Geometrical elements are next in terms of abundance: lozenges, triangles and rectangles, which could have formed a decorative band similar to that observed in the panels with *rotae* in the apse of San Vitale in Ravenna. Elements of an architectural partition were also identified: a fragment of a fluted lesena, two spirals from a 30-cm wide Ionic capital, four egg and dart mouldings from an Ionic kyma with the corresponding linings, and some arrow-shaped elements (Fig. 1a).

Other elements form a well-known pattern with four petals inscribed in a circle: two variants are attested, one with palombino petals on a red porphyry background and a specular one with red porphyry petals on a white background (Fig. 1b). The decoration is enriched by other floral patterns, conveying the idea of nature's vitality: acanthus gyral in fine-grain marble, with incised leaf veins; a four-petal flower, possibly surrounded by a gyral, as observed in the *domus* outside Porta Marina at Ostia⁷; and two other types of flowers, with elongated petals (Fig. 1c). Another floral pattern is formed by *peltae* and leaves within a squared frame, similar too to the samples from Porta Marina. Other elements, such as chalices, branches and pistils, give an idea of the diversity of the patterns. Finally, a *crusta* with a complex profile could be part of a vase.

Animals were most likely depicted in the branches, but only a protome with carved features and rubrication traces remains; based on comparison with similar *crustae* from the Euphrasian Basilica in Poreč⁸ and from the *domus* on the Esquiline Hill in Rome, it could be interpreted as a fish⁹ (Fig. 1d).

Therefore, beyond the usual geometrical repertoire common to other Milanese sites¹⁰, vegetal and floral

7 GUIDOBALDI 2000, 251–262 and references.

8 TERRY 1986, 147–164.

9 FOGAGNOLO 2011, 455–466.

10 *Crustae* from wall decorations have been identified in buildings with Imperial patronage (Herculean baths, Imperial palace, basilica of San Lorenzo) and in the churches founded by Ambrose. No systematic and comprehensive study of these materials has been carried out, which would allow their chronology to be clarified. The only context studied in detail is the baptistery of San Giovanni alle Fonti, dated to the 5th–6th c. phase; only there some figurative and geometric sectilia have been recognized (such as four-petal flowers, or patterns of alternated triangles and lozenges) similar to those suggested from the loose elements from the Mausoleum (LUSUARDI SIENA, SACCHI 2004).

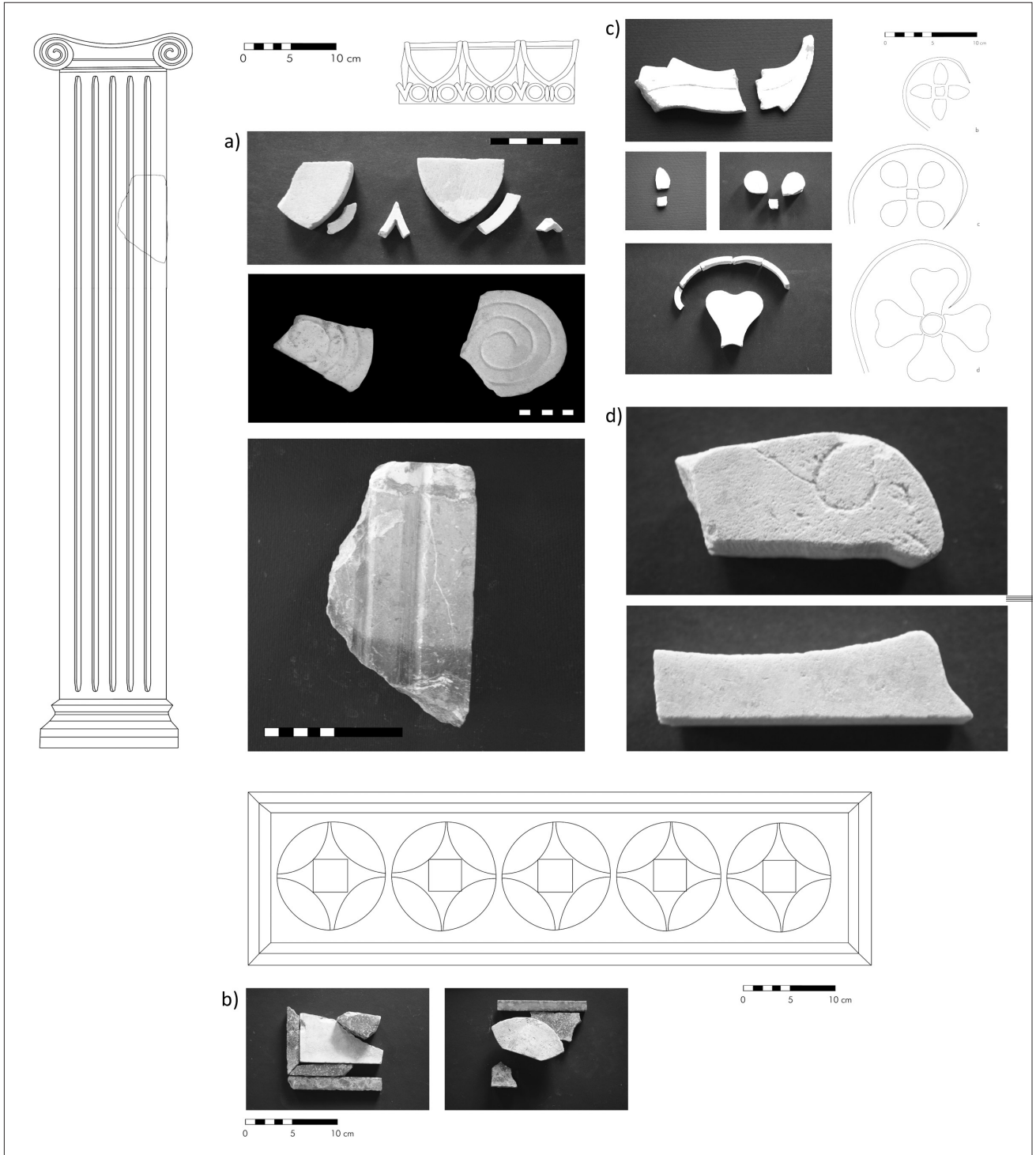

Fig. 1. Imperial Mausoleum (Milan Italy), *crustae*: a. architectural elements, b. vegetal elements, c. geometrical compositions, (photo: E. Neri)

motifs – more complex to execute – give the wall decoration a peculiar animation.

From a technical standpoint, the *crustae* have two flat sides, one of which is smoothed (more rarely two for the reused pieces). The side in contact with the mortar is sometimes not smoothed, but rather displays the marks of wire-sawing, i.e. slightly oblique and curved parallel grooves.

The thickness is rather regular within a given set of *crustae*. The cases of reuse or reworking are extremely sparse, as is the case for the site of Porta Marina at Ostia, but not for the urban *domus* on the Pincian and Esquiline hills as well as the so-called *domus* “above the Seven Halls”¹¹. The borders are carefully cut, edged and hewn with a “martellina”, except the curved listels that are neatly smoothed. All pieces except those in Nero delle Prealpi or Palombino are polished. A fragment of an alabaster slab is still clamped to its original cocciopesto mortar by an L-shaped bronzed clamp.

The decoration was integrated by small, thin glass elements coloured in purple, yellow and blue.

The scarcity of reused elements, the prevalence of precious imported marbles, the diversified repertoire of motifs and the integration of glass indicate exceptional standards for the workshop and the artisans, as well as for the financial and supply capacity of the customer. This observation is not surprising given the context of Imperial patronage; furthermore, it suggests that the decoration be dated to the time of the building’s conception or shortly afterwards.

The repertoire is similar to what the artisans used when working for the potentiores who financed not only the *domus* at Porta Marina, an inevitable reference thanks to its state of conservation, but also the urban *domus* “above the seven halls”, in the Cadorna barracks on the Esquiline Hill and on the Pincian Hill, where the same workers as at Porta Marina are supposed. The traces of similar decoration in Milan could be a confirmation that the models and the artisans from Rome circulated outside the city, as supposed already for the Spanish *villae* of Gabia la Grande, Elche and Antequera¹², which are chronologically near the construction of the Imperial mausoleum.

E.N.

2. San Lorenzo

Context

The church is built immediately outside the Roman gate (Porta Ticinese), on previously unoccupied land, surrounded by canals and near the fluvial harbour, not far from the amphitheatre whose conglomerate blocks (of Ceppo del Brembo stone) were reused for the basilica’s foundations.

The dating, patronage and original function of the church are still debated. However, especially since Laura Fieni’s studies, most scholars agree to date it between the late 4th and the early 5th c., based on archaeological and archaeometric elements (dating of pottery from an excavation below the façade and of the amphorae from the dome’s cover; construction technique). Thermoluminescence dating of the bricks and C14 analyses of mortar return an average dating between 390 and 410. The grandeur of the construction, the richness of the decoration and the reuse of material from public buildings tied to the Imperial authority suggest that the customer was the Emperor himself or a member of his family: Theodosius, who died in Milan in 395; Stilicho, the Barbarian general whom he left as a regent; or Galla Placidia, his daughter, as stated by post-9th c. sources. More recently, patronage by Valentinian III was proposed¹³.

Written sources repeatedly highlight the presence of magnificent marble covering. Bishop Veranus of Cavaillon (+589), who was in Milan on St. Lawrence’s day on his way back from Rome and had already visited Ravenna, thought that San Lorenzo was the most beautiful church in Italy (*domus mirificam*). The *Versus de Mediolano civitate* (8th c.) takes the church as an example of the splendour of the city, with its interior (*alma intus*) shining with a variety of marbles and a gold cover. Later sources insist on the presence of porphyry and gold, two materials linked with the Imperial functions of the church. According to the 9th-c. bishop Benzo of Alba, “there is no more beautiful church in Italy” than San Lorenzo, “all in porphyry and gold” (*Ad Heinricum imperatorem libri VII*, MGH, *In usum scholarum*, LXV, SS, XI). The three chapels of Sant’Aquilino, Sant’Ippolito and San Sisto also had a decoration similar to that of the central part of the church.

For Sant’Aquilino in particular, the only chapel with surviving decoration, Galvano Flamma (*Chronica extravagans* and *Chronica maior*, 14th c.) recalls the ornaments in porphyry and other precious marbles. Carlo Torre (*Il ritratto di Milano*, 1674) records the presence of round slabs of precious marble between the arches.

11 For Porta Marina at Ostia, see GUIDOBALDI 2000. For the urban *domus* on the Esquiline and Pincian hills, see respectively FOGAGNOLO 2011 and RONCHETTI 2009, 241–252. For the *domus* “above the seven halls”, see BIANCHI, BRUNO, DE NUCCIO 2002, 161–168 and 465.

12 PEREZ OLMEDA 1996, 81–82, 133–134. GUTIÉRREZ DEZA 2005, 71–86.

13 NERI, LUSUARDI SIENA, GREPPI 2015b.

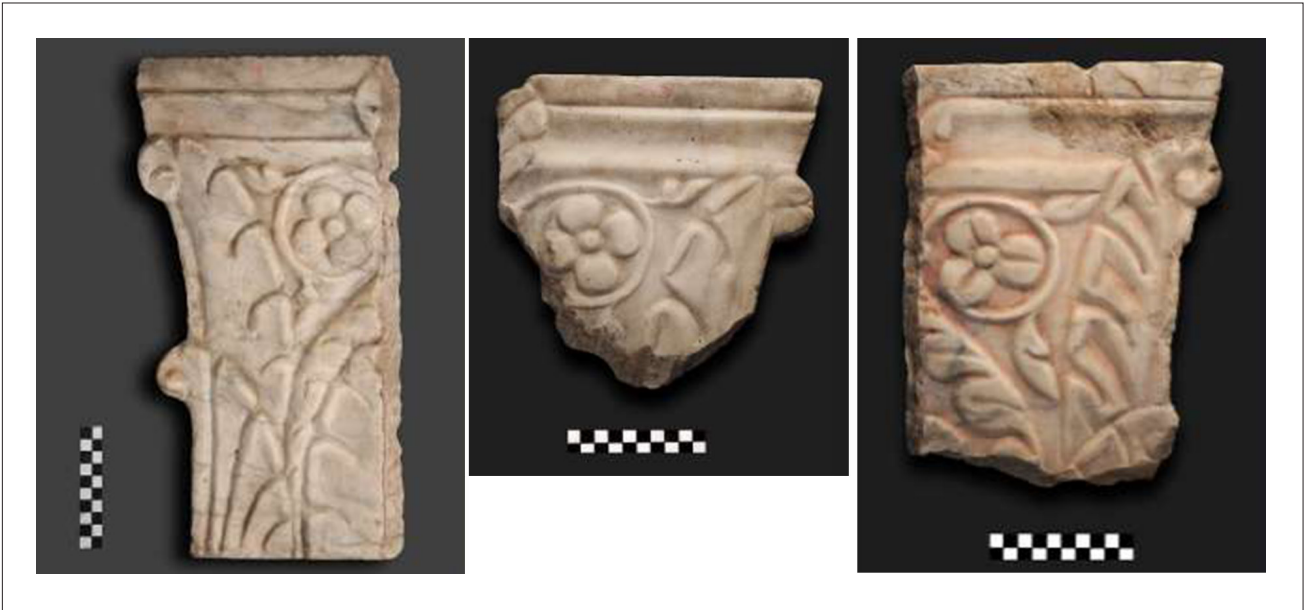

Fig. 2. Basilica of San Lorenzo (Milan, Italy), chapel of Sant'Aquilino, inlaid marble: pseudo-Corinthian capitals (2 c. AD) of pilaster, re-use in the 5 c. decoration (photo: C. Bozzi)

Non-stratigraphic excavations and restorations, carried out in 1913 and 1937, revealed numerous fragments of the marble wall decoration, but only now are they studied systematically. Due to the excavation procedures, these fragments do not have a context, other than a generic attribution to the central part (tetraconch) of the church or to Sant'Aquilino.

E.N.

Marble decoration in Sant'Aquilino

A wide range of decoration types has been found for Sant'Aquilino¹⁴. The octagon was probably decorated with an architectural partition: the remains consist of two fragments of wide slabs, similar to those found in the villa of Toscolano Maderno¹⁵ and in the apse of San Vitale, as well as bases (3 fragments) and shafts (6 fragments) of fluted lesenae in cipollino marble, topped with reused 2nd c. capitals in fine-grained white and rubricated marble (Fig. 2). The lesenae have two types of fluting, suggesting that they were used in different locations or in a corner (Fig. 3). Curved listels framing large circular slabs demonstrate the presence of *rotae* (Fig. 4).

On top of geometrical patterns – a trace of which remains imprinted in the original mortar, still preserved in the chapel – carved or bas-relief slabs in cipollino from Euboea, displaying friezes with gyral, vases, and naturalistic

figures (birds, fish, etc.), enriched the decoration (Fig. 5). Some carved fragments with branches stemming from a *cantharos*, as well as fragments from a slab showing gyral from a chalice, rendered in bas-relief with a raw background (Fig. 6 and 7), deserve a specific mention¹⁶.

E.N.

Marble decoration from the tetraconch of the church

The remains of the decoration of the central part of the basilica are more fragmentary but more abundant (1450 *crustae*)¹⁷.

There is little information available on the context where the fragments were found: Calderini, Chierici and Cecchelli¹⁸ report piles of stone elements of various types, mixed with demolition materials, as generically found in the main hall of the church.

A large variety of marble is attested: both local materials (Majolica limestone and Nero delle Prealpi) and imported stones are represented. White “marbles” are predominant, accounting for 49% of the fragments; among these, medium-grained marble is prevalent, followed by coarse-grained and fine grained marble,

16 These remains are currently on exhibit in Sant'Aquilino.

17 All the materials are now in the upper gallery of the church. For the followed methods see ANGELELLI, GUIDOBALDI 2002, 155–163, with some modifications proposed in FURLAN, MADRIGALI 2009, 817–851.

18 CALDERINI, CHIERICI, CECHELLI 1951, 88.

14 LUSUARDI SIENA 1990.

15 SACCHI 2015.

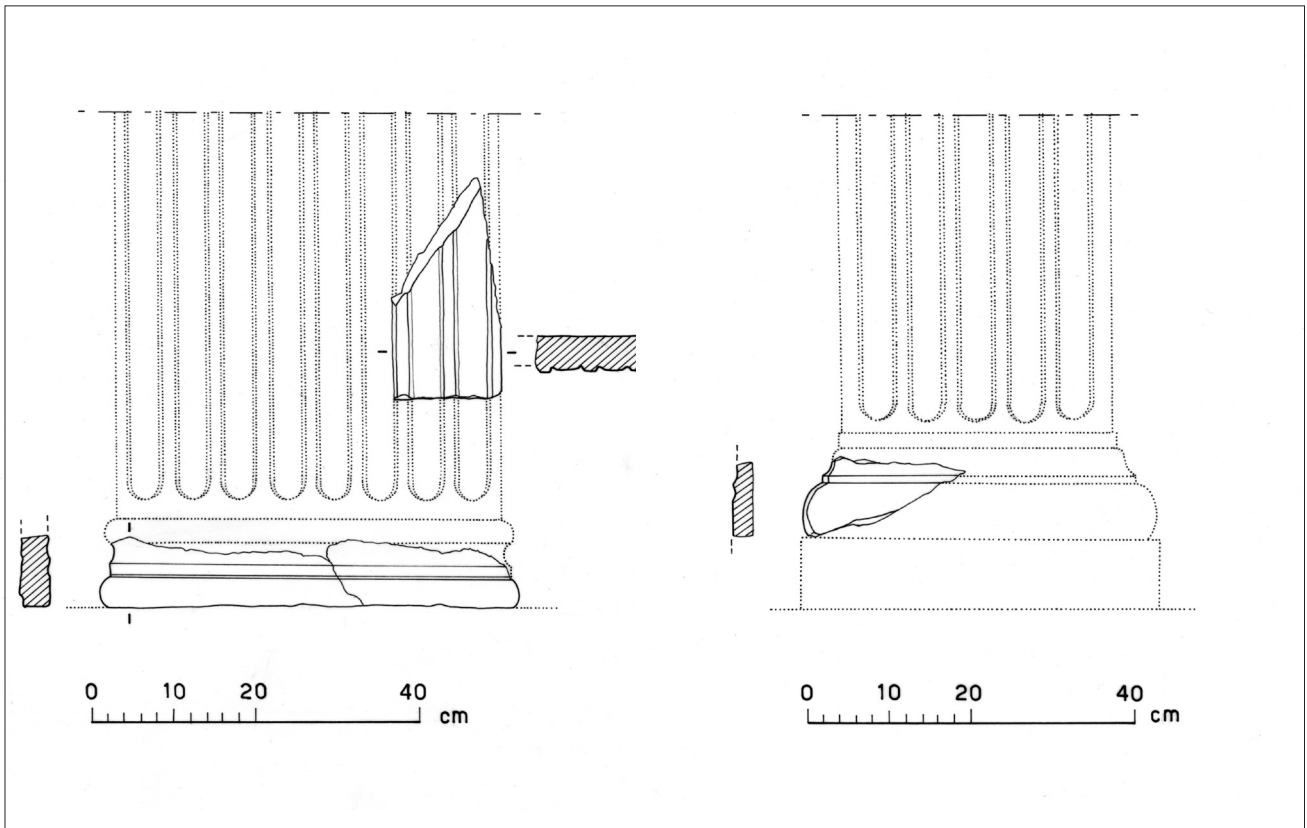

Fig. 3. Basilica of San Lorenzo (Milan, Italy), chapel of Sant'Aquilino, inlaid marble: elements of pilaster (drawing: R. Rachini)

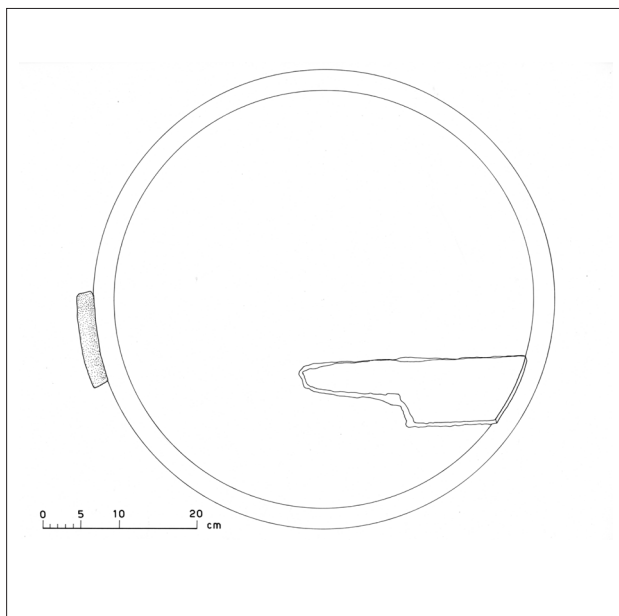

Fig. 4. Basilica of San Lorenzo (Milan, Italy), chapel of Sant'Aquilino, inlaid marble: elements of *rotae* (drawing: R. Rachini)

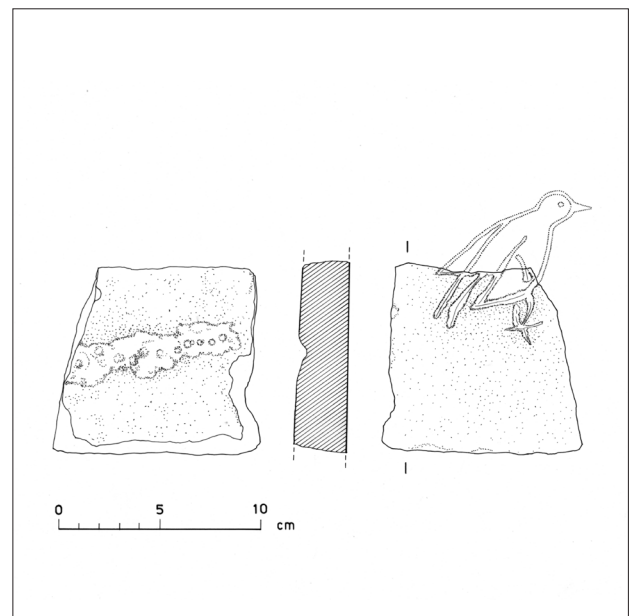

Fig. 5. Basilica of San Lorenzo (Milan, Italy), chapel of Sant'Aquilino, inlaid marble with bird (drawing: R. Rachini)

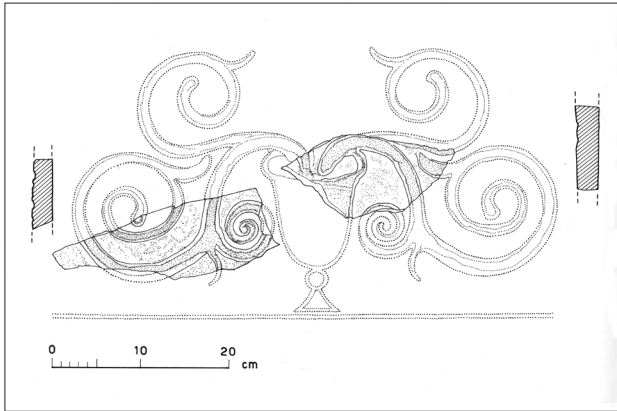

Fig. 6. Basilica of San Lorenzo (Milan, Italy), chapel of Sant'Aquilino, inlaid marble with vase and vegetal gyral (drawing: R. Rachini)

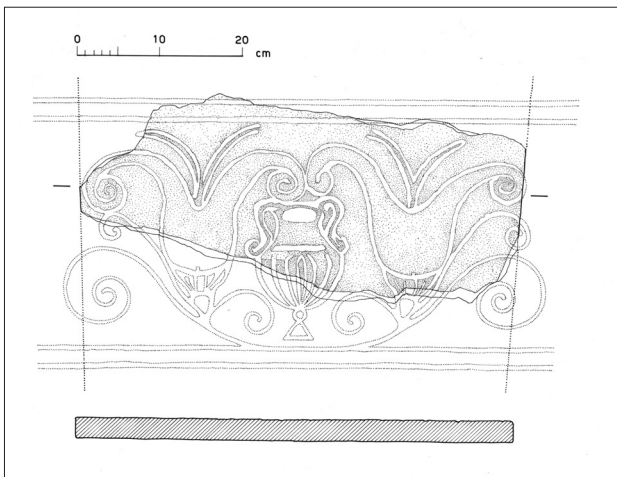

Fig. 7. St. Lorenzo church (Milan, Italy), St. Aquilino chapel, inlaid marble with Kantharos and floral gyral (drawing: R. Rachini)

Proconnesian marble, Thassos marble, Majolica limestone, Musso marble, Botticino stone and very thin-grained marbles. A large variety of coloured marbles has been observed, representing 41% of the observed fragments. The most frequently attested is “pavoazetto”, followed by Giallo antico; less frequent lithotypes include Cipollino, Rosso Antico, Breccia Corallina, Africano, Fior di Pesco, Portasanta, Bianco and Nero Antico, Rosso Ammonitico, Grigio Arabescato and Greco Scritto. The limited presence of porphyry is remarkable: Imperial porphyry is represented by one small fragment, whose shape suggests it belonged to a curved element of a frame, and green porphyry is also observed in only one fragment. Black limestone from the Lombard Alpine foothills (Nero delle Prealpi, most likely from the “Calcarei di Perledo e Varenna” Triassic formation) represent 10% of the fragments.

In terms of shapes, a reduced number of squares and hexagons is observed (respectively 4 and 9 samples), with varying thickness and sizes. This is in contrast with a large number of triangles, made of white and coloured marbles and black limestone, which could have formed linear bands¹⁹ as suggested by the presence of isosceles triangles²⁰. Lists of white and coloured marble are also abundant, hinting at the presence of square or rectangular bands and borders. In terms of filling, large slabs of cipollino²¹ and black limestone are found, as well as the only fragment of green porphyry. Lozenges are also observed, especially in white and coloured marble, with some samples in Nero delle Prealpi; they were most likely used in bands.

Curved elements made of Numidian marble have been identified; they are very thin (ca. 0.8 cm) and cut with a saw on both faces. However, no other reference in the studied materials allows the reconstruction of a hypothetical pattern for this decoration. Another typical element is a triangle with two curved sides: together with other pieces with complex outline it suggests the presence of figurative elements (Fig. 8).

The *crustae* from this site have different characteristics. More than half of the fragments have both faces smoothed; the most notable exceptions are almost all the Nero delle Prealpi and Majolica fragments, as well as most of the Giallo antico fragments. In particular, black limestone fragments always have a coarse face and a smooth one, although the latter has a grey patina that sometimes hides the manufacturing features. Majolica and Giallo antico fragments show clear traces of chiselling, i.e. large conchoidal chipping, suggesting that the chisel was used perpendicularly or at a 75-degree angle²².

In this context, it was not possible to identify the provenance of the elements from the same motif; however, it can be assumed that the materials belonged to different parts of the decoration and have been collected in one point after an accidental event. Some of the element display marks of fire, suggesting that the slabs were found with the remains of the early medieval destruction of the building, and had already been selected in ancient times.

S.G.

19 GUIDOBALDI 2009, fig. 14 c; BUGINI, FOLLI 2008, fig. 5.5.

20 GUIDOBALDI 2009, tav IV.F.

21 Fields in Cipollino have been also observed in San Giovanni alle Fonti (LUSUARDI SIENA, SACCHI 2004, 87).

22 ROCKWELL 1989.



Fig. 8. St. Lorenzo church (Milan, Italy), Tetraconch, inlaid marble with geometric pattern

3. Comparison

The comparison between the two sites shows that a figurative decoration, with small elements to render the details of floral, vegetal and animal motifs, was in place at the Imperial mausoleum. This explains the wide use of palombino, absent from San Lorenzo and from all other Milanese sites with marble decoration. The first parallel in Northern Italy comes from the recent study of the *crustae* from the villa in Toscolano Maderno²³. Moreover, some lithotypes in the Mausoleum are not attested in San Lorenzo, e.g. “African” marble and Egyptian alabaster. The use of Imperial porphyry and green porphyry are more significant in the Mausoleum, although a selection of the marbles in ancient times has to be accounted for; the use of local marbles (Nero delle Prealpi and Botticino stone) is limited here, but widely documented in San Lorenzo.

The decoration in San Lorenzo and Sant’Aquilino primarily consists of geometrical motifs and architectural

partitions. These partitions and the carved slabs are mostly made with Cipollino, newly graving re-used ancient slabs or reusing 2nd c. architectural elements.

Though the reuse of older marble slabs is frequent, the technical know-how required to smooth, cut and polish the *crustae* does not change.

The mid-4th c. phase of the Imperial mausoleum includes an unusual type of figurative decoration, generally associated in literature with craftsmen from Rome²⁴. The supply of (mostly new) coloured marble confirms the high-level patronage and its financial capacity at a time when the Imperial court resided in Milan. The 5th c. works in San Lorenzo, as shown for the construction materials as well²⁵, mostly reuse coloured marble slabs or architectural elements from other buildings, working them with the same techniques but using a larger proportion of locally sourced materials.

E.N.–R.B.

23 SACCHI 2015.

24 NERI *et al.* 2015a.

25 FIENI 2014.

REFERENCES

- ANGELELLI C., GUIDOBALDI F. 2002: "Frammenti di opus sectile come materiali da scavo: criteri di individuazione, classificazione", in G. BISCONTIN, G. DRIUSSI (eds.): *I Mosaici. Cultura, Tecnologia, Conservazione* (Atti del convegno di studi, Bressanone 2-5 luglio 2002), Venezia, 155-163.
- BIANCHI F., BRUNO M., DE NUCCIO M. 2002: "La domus sopra le Sette Sale: la decorazione pavimentale e parietale dell'aula absidata", in *I marmi colorati*, 61-168.
- BUGINI R., FOLLI L. 2008: "Pavimenti in Opus Sectile a Milano e in Lombardia. L'uso dei calcari neri", in *V Congresso Nazionale AIAR*, 265-278.
- BUGINI R., FOLLI L. 2015: "L'identificazione dei marmi della villa: indagini mineralogico-petrografiche" in I. ROFFIA (ed.): *La villa romana dei Nonii - Arrii a Toscolano Maderno*, Milano, 247-257.
- CALDERINI A., CHERICI G., CECHELLI C. 1951: *La basilica Maggiore di San Lorenzo in Milano*, Milano.
- FIENI L. 2004: *La costruzione della basilica di S. Lorenzo*, Milano.
- FOGAGNOLO S. 2011: "Nuove acquisizioni di opus sectile parietale e pavimentale dagli scavi della caserma 'R. Cadorna' all'Esquilino", in *AISCOM XVI*, 455-466.
- FURLAN G., MADRIGALI E. 2009: *I marmi di rivestimento in Nora. Il foro romano*. Padova, 817-851.
- GNOLI R. 1988: *Marmora Romana*, Roma.
- GUIDOBALDI F. 2000: "La decorazione in *opus sectile* dell'aula", in S. ENSOLI-E. LA ROCCA (eds.): *Aurea Roma: dalla città pagana alla città cristiana*, 251-262.
- GUIDOBALDI F. 2009: "Sectilia pavimenta tardoantichi e paleocristiani a piccolo modulo in Italia settentrionale", in *Rivista di Archeologia Cristiana*, 85, 355-419.
- GUTIÉRREZ DEZA M. I. 2005: "Sectile figurado de la Villa de la Estación de Antequera", *Mainake*, XX-VII, 71-86.
- I Marmi Colorati della Roma Imperiale*, M. DE NUCCIO, L. UNGARO (eds.), Venezia.
- LUSUARDI SIENA S. 1990: "2a36. Il complesso laurenziano. L'arredo interno e i rivestimenti parietali", in *Milano capitale dell'impero romano (286-402 d.C.)*, Milano, 143-144.
- LUSUARDI SIENA S., SACCHI F. 2004: "Per un riesame dei sectilia parietali paleocristiani del battistero di S. Giovanni alle Fonti a Milano", in S. LUSUARDI SIENA, F. SACCHI (eds.): *I colori ritrovati. Il contributo dell'archeologia alla conoscenza degli elementi di arredo nell'architettura tra tarda antichità e medioevo*, Milano, 145-159.
- LUSUARDI SIENA S., NERI E. 2013: "La basilica portiana e S. Vittore al Corpo: un punto di vista archeologico", in *Ambrogio e l'arianesimo*, *Studia ambrosiana* 7, 147-192.
- Marmi antichi*, G. BORGHINI (ed.), Roma 1989.
- NERI E., BUGINI R., VERITÀ M. 2015a: *Frammenti della decorazione parietale del mausoleo imperiale di Milano (IV sec.): i materiali e la loro caratterizzazione*, XX Colloquio AISCOM (Roma, 19-22 marzo 2014), Tivoli, 159-169.
- NERI E., LUSUARDI SIENA S., GREPPI P. 2015b: *Il problema della cronologia del cantiere di San Lorenzo a Milano. Vecchi e nuovi dati a confronto*, in *Il culto di San Lorenzo tra Milano e Roma*, *Studia ambrosiana* 8, 115-164.
- PEREZ OLMEDA E. 1996: *Revestimentos de "Opus sectile" en la Península ibérica*, Madrid.
- ROCKWELL P. 1989: *Lavorare la pietra: manuale per l'archeologo, lo storico d'arte e il restauratore* (Beni culturali 7), Roma.
- RONCHETTI E. 2009: *Opus sectile parietale da una residenza sul Pincio*, in *AISCOM XII*, 241-252.
- SACCHI F. 2015: "La decorazione marmorea e gli arredi lapidei", in I. ROFFIA (ed.): *La villa romana dei Nonii - Arrii a Toscolano Maderno*, Milano, 236-247.
- SANNAZARO M. 2015: "Lo sviluppo urbanistico di Milano in età paleocristiana", *Atti del Seminario interdisciplinare 'Milano Archeologia per Expo 2015'*, *Lanx* 19, 79-94.
- TERRY A. 1986: *The Opus sectile in the Euphrausius cathedral at Poreč*, *DOP* 40, 1986, 147-164.