

Projekt čelične konstrukcije "Zeleni inkubator"

Blažević, Mia

Master's thesis / Diplomski rad

2020

Degree Grantor / Ustanova koja je dodijelila akademski / stručni stupanj:

University of Split, Faculty of Civil Engineering, Architecture and Geodesy / Sveučilište u Splitu, Fakultet građevinarstva, arhitekture i geodezije

Permanent link / Trajna poveznica: <https://um.nsk.hr/um:nbn:hr:123:965025>

Rights / Prava: [In copyright](#)/[Zaštićeno autorskim pravom.](#)

Download date / Datum preuzimanja: **2025-02-18**



Repository / Repozitorij:

[FCEAG Repository - Repository of the Faculty of Civil Engineering, Architecture and Geodesy, University of Split](#)



UNIVERSITY OF SPLIT



DIGITALNI AKADEMSKI ARHIVI I REPOZITORIJI

**SVEUČILIŠTE U SPLITU
FAKULTET GRAĐEVINARSTVA ARHITEKTURE I GEODEZIJE**

DIPLOMSKI RAD

Mia Blažević

Split, 2020.

**SVEUČILIŠTE U SPLITU
FAKULTET GRAĐEVINARSTVA ARHITEKTURE I GEODEZIJE**

Mia Blažević

Projekt čelične konstrukcije "Zeleni inkubator"

Diplomski rad

Split, 2020.

SVEUČILIŠTE U SPLITU

FAKULTET GRAĐEVINARSTVA, ARHITEKTURE I GEODEZIJE

STUDIJ: DIPLOMSKI SVEUČILIŠNI STUDIJ GRAĐEVINARSTVA

KANDIDAT: Mia Blažević

BROJ INDEKSA: 758

KATEDRA: Katedra za metalne i drvene konstrukcije

PREDMET: Metalne konstrukcije

ZADATAK ZA DIPLOMSKI RAD

Tema: Projekt čelične konstrukcije "Zeleni inkubator"

Opis zadatka: Na temelju arhitektonskih podloga potrebno je izraditi projekt čelične konstrukcije termalno lječilišnog kompleksa "Zeleni inkubator".

Projekt konstrukcije treba sadržavati:

- Tehnički opis
- Proračune nosivih elemenata i priključaka
- Građevinske nacрте

U Splitu, ožujak 2020.

Voditelj Diplomskog rada:

prof.dr.sc.Ivica Boko

Predsjednik Povjerenstva

za završne i diplomske ispite:

Doc. dr. sc. Ivo Andrić

Projekt čelične konstrukcije "Zeleni inkubator"

Sažetak:

Prema arhitektonskim podlogama i urbanističkim planovima izrađen je projekt čelične konstrukcije "Zeleni inkubator" - termalno-lječilišni kompleks. Arhitektonskim podlogama zadane su uzdužna, poprečna i tlocrtna dispozicija kao i profili konstruktivnih elemenata. Na temelju zadanih podataka napravljen je numerički model na kojem je izvršeno dimenzioniranje svih konstruktivnih elemenata. Također je izvršen je i proračun spojeva i izrađeni su svi građevinski nacrti. Svi proračuni izvedeni su prema EC normama.

Ključne riječi:

Čelična konstrukcija, spojevi, nacrti, numerički model, Eurocode

Abstract: Steel structure project "Zeleni inkubator" - thermal spa complex - was made according to architectural project and urbanism solutions for the area. The architectural project contained ground, longitudinal and transversal plans as well as the type of cross sections for structural elements. On the basis of given data, numerical model has been made on which the calculations for the dimensions of the elements were conducted. Also, the project contains steel joints designs as well as all the construction drawings. All calculations were conducted under the Eurocode norms.

Keywords:

Steel structure, joints, drawings, numerical model, Eurocode

Zahvala

Zahvaljujem obitelji i prijateljima na podršci i pomoći te mentoru na strpljenju i stručnoj pomoći prilikom izrade ovog rada.

Sadržaj:

1.	Uvod – o konstrukciji	1
2.	Tehnički opis	2
2.1.	O proračunu konstrukcije	2
2.2.	Materijal za izradu konstrukcije i elementi konstrukcije.....	3
2.3.	Montaža konstrukcije	4
2.4.	Primijenjeni propisi	4
2.5.	Protupožarna zaštita.....	4
2.6.	Antikorozivna zaštita.....	5
3.	Numerički model konstrukcije	7
4.	Analiza opterećenja	9
4.1.	Stalno opterećenje – vlastita težina	9
4.2.	Dodatno stalno opterećenje	9
4.3.	Korisno opterećenje	11
4.4.	Opterećenje snijegom	12
4.5.	Opterećenje vjetrom	15
4.6.	Temperaturno djelovanje	20
5.	Kombinacije djelovanja za GSN i GSU	22
6.	Kontrola pomaka – Granično stanje uporabljivosti (GSU).....	29
6.1.	Horizontalni pomaci	29
6.2.	Vertikalni progib rešetke	30
7.	Dimenzioniranje elemenata – Granično stanje nosivosti (GSN)	31
7.1.	Glavna rešetka	31
7.1.1.	Gornji pojas glavne rešetke – Pozicija 1	31
7.1.2.	Donji pojas glavne rešetke – Pozicija 2	37
7.1.3.	Ispune glavne rešetke – Pozicija 3	42
7.2.	Bočna rešetka.....	48
7.2.1.	Gornji pojas bočne rešetke – Pozicija 4	48
7.2.2.	Donji pojas bočne rešetke – Pozicija 5.....	54
7.2.3.	Ispune bočne rešetke – Pozicija 6	60
7.3.	Krovne podrožnice – Pozicija 7.....	66
7.4.	Vanjske grede – Pozicija 8	73
7.5.	Veliki stup – Pozicija 9.....	79
7.6.	Mali stup – Pozicija 10	82
7.7.	Unutarnje grede – Pozicija 11	88

7.8. Unutarnji stup – Pozicija 12	93
8. Težina konstrukcije	100
9. Proračun spojeva	101
9.1. Spoj velikog stupa s temeljem	101
9.2. Spoj malog stupa s temeljem	107
9.3. Spoj velikog stupa s donjim pojasom glavne rešetke	113
9.4. Nastavak gornjeg pojasa bočne rešetke	120
9.5. Nastavak donjeg pojasa bočne rešetke	126
9.6. Nastavak ispune bočne rešetke	132
9.7. Spoj donjeg pojasa bočne rešetke i ispuna	138
9.8. Spoj gornjeg pojasa bočne rešetke i ispuna	145
9.9. Spoj grede sa zidom.....	152
9.10. Nastavak gornjeg pojasa glavne rešetke	158
9.11. Nastavak donjeg pojasa glavne rešetke.....	164
9.12. Nastavak ispuna glavne rešetke	170
9.13. Spoj gornjeg pojasa glavne rešetke s ispunama	176
9.14. Spoj donjeg pojasa glavne rešetke s ispunama	183
9.15. Nastavak podrožnice	190
9.16. Spoj stupa sa gredama.....	196
10. Dimenzioniranje temelja samca	206
11. Popis grafičkih priloga	207
12. Literatura	208

1. Uvod – o konstrukciji

Lokacija Blato jedno je neizgrađeno veće područje, a nalazi se ne tako daleko od Jaruna i drugih izgrađenih i naseljenih dijelova Zagreba. Kao rub grada ona ima potencijal da postane ravnoteža izgrađenog i neizgrađenog, grada i sela, odnosno rurbano naselje. U konceptu arhitekture i urbanizma iskoristio se taj potencijal pri kreiranju objekta u kojem su zatvoreni puni volumeni minimizirani i razdvojeni, a između njih se prostiru velike staklene cjeline sustava bazena koje propuštaju prirodu s obje strane zgrade. Zgrada se sastoji od velikog prostora s bazenima koji su smješteni u prizemlju. Puni volumeni sadrže ostale srodne sadržaje koji nisu u direktnoj vezi s bazenima. Oni imaju vlastite ulaze i komunikaciju na prvoj etaži. Rubni zatvoreni volumen ima na etažama terapijske sadržaje dok su središnji volumeni namijenjeni treningu i ugostiteljstvu.

Betonski volumeni su izvedeni kao troslojni zid s vanjskom nosivom betonskom fasadom izvedenom od oplata drvenih trupaca koji joj daju posebnu teksturu i dojam špilje. Čelična konstrukcija između obložena je čitava staklenim stijenama, kao i krov. Južne padine krova su stakleni fotovoltaići kojima se prikuplja sunčeva energija. Pod na dijelovima s bazenima je profilirani protuklizni betonski sa sitnim agregatom i ugrađenim podnim grijanjem.

Temelji su proračunati kao armirano-betonski temelji samci no zapravo se povezuju u trakasti temelj zbog male udaljenosti stupova. Iznad temelja postavljena je temeljna armirano-betonska ploča. Tlocrtni gabariti objekta su cca. 50m x 160m, a visina objekta je cca. 8,70m.



Slika 1.1. Blato

2. Tehnički opis

2.1. O proračunu konstrukcije

Proračun konstrukcije napravljen je uz pomoć programskog paketa SCIA Engineer 19.1. Proračun reznih sila, te dimenzioniranje konstruktivnih elemenata provedeno je korištenjem programa SCIA Engineer 19.1. Priključci su proračunati uz pomoć programa IDEA StatiCa, dok je za grafički dio projekta korišten AutoCAD 2018.

Proračun reznih sila izvršen je po linearnoj teoriji elastičnosti prvog reda. Proračunom su obuhvaćena sva djelovanja na konstrukciju, a to su: vlastita težina, dodatno stalno opterećenje, pokretno opterećenje, opterećenje snijegom, vjetrom i djelovanje temperature. Potres nije uračunat s obzirom na visinu objekta na koji kao takav djeluje neznatno u odnosu na ostala opterećenja.

S obzirom na lokaciju objekta napravljena je analiza opterećenja koja obuhvaća djelovanje snijega i vjetra. Objekt se nalazi na području Zagreba, te prema karti snijega za Republiku Hrvatsku ova građevina spada u 3. područje – kontinentalna Hrvatska, što određuje karakterističnu vrijednost opterećenja snijegom na tlu. U obzir je uzeta i nadmorska visina na kojoj se nalazi objekt. Za opterećenje vjetrom odabrana je zona III, kategorija zemljišta 0, te je u obzir uzeta visina objekta i njegova zaštićenost.

Za svaki element konstrukcije određena je mjerodavna kombinacija opterećenja za provjeru krajnjeg graničnog stanja i graničnog stanja uporabivosti. Za svako granično stanje napravljene su posebne kombinacije uz poštivanje parcijalnih faktora sigurnosti prema EN 1991.

Rezultati uključuju rezne sile i pomake određenih dijelova konstrukcije. Rezne sile su dane u jedinicama kN za poprečne i uzdužne sile, kNm za momente, te u mm za pomake konstrukcije. U obzir su uzete sve mjerodavne kombinacije opterećenja, te je svaki element dimenzioniran sukladno njegovim reznim silama.

2.2. Materijal za izradu konstrukcije i elementi konstrukcije

Betonski dio konstrukcije izrađen je od betona klase C35/45, kao i temelji. Za armaturu temelja predviđena je armatura B500B.

Materijal za izradu čeličnog dijela, odnosno glavne rešetke, bočne rešetke, stupova i greda je čelik S355. Konstruktivni elementi biti će međusobno vezani vijčanim ili zavarenim spojevima. Vijci korišteni za izradu tih spojeva su M12, M16, M22, M27 i M30 svi kvalitete 10.9. Spojevi također sadrže dodatne pločice različitih dimenzija, no iste kvalitete čelika (S355).

Za glavnu rešetku odabrani su šuplji pravokutni profili dimenzija:

- CFRHS 200x100x10 za gornji pojas rešetke
- CFRHS 200x100x12,5 za donji pojas rešetke
- CFRHS 140x80x6 za ispune rešetke

Za bočnu rešetku:

- CFRHS 200x100x10 za gornji pojas rešetke
- CFRHS 200x100x12,5 za donji pojas rešetke
- CFRHS 100x60x6 za ispune rešetke

Za vanjske stupove:

- CFRHS 180x120x10 za veći upeti stup
- CFRHS 120x120x6 za manji stup

Za podrožnice je predviđen I profil:

- HEB240

Za vanjske grede:

- CFRHS 80x60x5

Za elemente unutar objekta predviđeni su sljedeći profili:

- HEB 160 za grede za koje je predviđeno sprezanje s ab pločom
- HEM 280 za stupove koji su tlocrtno postavljeni na rubovima predviđenih pregradnih zidova (u dogovoru s arhitektom, kako bi omogućili fleksibilnije pregrađivanje i eventualnu prenamjenu prostora, eliminirani su nosivi betonski zidovi i zamijenjeni sa čeličnim stupovima)

2.3. Montaža konstrukcije

Izvedba čeličog dijela konstrukcije je montažna. Svi elementi konstrukcije predgotovljeni stižu na gradilište te se međusobno vežu vijcima.

Nulta faza montaže, nakon izvedenih svih predhodno potrebnih radova, je montaža stupova. Stup se pridržava dizalicom dok se ne postigne vertikalnost pomoću dvostrukih vijaka. Nakon provjere vertikalnosti, vrši se ispunjenje prostora između spojne i betonske ploče ekspanzirajućim mortom. Nakon toga se na stupove vežu grede međukatne konstrukcije i glavni i sekundarni rešetkasti nosači.

Svi elementi konstrukcije se dovoze na gradilište duljine do 15 m zbog transporta. Na gradilištu se spajaju u veće segmente i takvi podižu dizalicom na predviđenu poziciju te vijčano i zavarima spajaju na ostatak konstrukcije.

2.4. Primijenjeni propisi

Proračun i dimenzioniranje svih elemenata čelične konstrukcije provedeni su u skladu sa EUROCODE-om 3, a analiza djelovanja na konstrukciju napravljena je u skladu sa EUROCODE-om 1. Posebno je proveden proračun zavarenih spojeva prema EN 1993, dio 1-8

2.5. Protupožarna zaštita

Pri izvedbi osigurati će se provedba svih propisa o zaštiti od požara. Pristup i intervencija vatrogasnog vozila omogućiti će se sa sjeverne strane parcele. Zahtijevana vatrootpornost elemenata čelične konstrukcije je F30. Osiguranje vatrootpornosti osiguravamo specijalnim ekspanzirajućim premazima.

2.6. Antikorozivna zaštita

Kod čelika se pod korozijom podrazumijeva oksidacija željeza pri djelovanju vlage i raznih nečistoća. Agensi koji ubrzavaju hrđanje su zagađena atmosfera, industrijsko područje zagađeno sumporom, sol itd.

Zaštita čeličnih konstrukcija od hrđanja vrši se:

- premazima
- cinkom
- metalizacijom
- uporabom specijalnih čelika
- katodnom zaštitom

Zaštita premazima obavlja se u svrhu sprječavanja kontakta kisika i vlage sa čelikom. Premazivanje se obično vrši bojanjem u dva sloja: osnovni premaz i zaštitni premaz. Osnovni premaz neposredno štiti čelik, a mora biti izrađen od tvari koje nisu štetne po ljudsko zdravlje. Zaštitni sloj služi za zaštitu osnovnog premaza.

Prerano propadanje konstrukcije najčešće nastaje uslijed loših detalja u konstrukciji (nepristupačna mjesta za bojenje, mjesta gdje se zadržava voda, oštri bridovi gdje se ne može nanijeti zahtjevana debljina premaza i i sl.) koje treba nastojati izbjegavati.

Sistem zaštite bojom sastoji se iz:

- pripreme površine – trajnost premaza ovisi o prionjivosti boje za metalnu površinu, što ovisi o čistoći površine prije bojanja. Čišćenje se vrši četkama, pjeskarenjem, plamenikom ili kemijskim sredstvima.

- nanošenje boje – bojenje se vrši četkom, valjkom ili prskanjem. Treba paziti na ograničenja za pojedine boje. Broj slojeva premaza obično se sastoji od dva, a specifično od četiri ili više slojeva. Novi premaz može se vršiti tek kada je prethodni potpuno suh. Debljini premaza potrebno je posvetiti posebnu pažnju. Općenito, deblji premaz povećava trajnost zaštite. Ukupna debljina suhih premaza treba se kretati između 0,1-0,4mm.

Dobro izvedeni premazi traju:

- do 30 godina u zatvorenoj prostoriji
- do 20 godina kod konstrukcija zaštićenih od kiše
- do 10 godina u prirodi
- 2 do 3 godine u zagađenom okolišu

Zaštita pocinčavanjem podrazumijeva vrste zaštite koje se ostvaruju nanošenjem prevlake cinka. Mase i debljine prevlaka cinka za pojedine elemente određene su prema Pravilniku o tehničkim mjerama i uvjetima za zaštitu čeličnih konstrukcija od korozije i ne mogu biti manje od 500g/m² elementa debljine 5 mm. Sve čelične konstrukcije prethodno treba odmastiti, očistiti razblaženom otopinom klorovodične kiseline te isprati hladnom vodom. Neposredno prije pocinčavanja čelična konstrukcija se stavlja u taljevinu ili otopinu za flusiranje.

Toplo pocinčavanje se izvodi stavljanjem tekućine u rastopljeni cink. Cink mora biti kvaliteta Zn 97,5 do Zn 99,5 prema HRN EN ISO 14713:2001. Prevlaka cinka dobivena toplim postupkom mora biti homogena i mora prekrivati osnovicu. Prevlaka cinka mora čvrsto prianjati za čeličnu površinu i ne smije se ljuštiti niti pucati pri uporabi. Prije montaže potrebno je izvršiti kontrolu prevlake cinka prema HRN C.A1. 558, odnosno mase prevlake cinka prema HRN A6.021.

Zbog specifičnosti konstrukcije, odnosno kategorije korozivnosti C5-I usvojena ukupna debljina zaštitnog sloja je 320 µm.

3. Numerički model konstrukcije

Numerički 3D model izrađen je u SCIA Engineer 19.1.

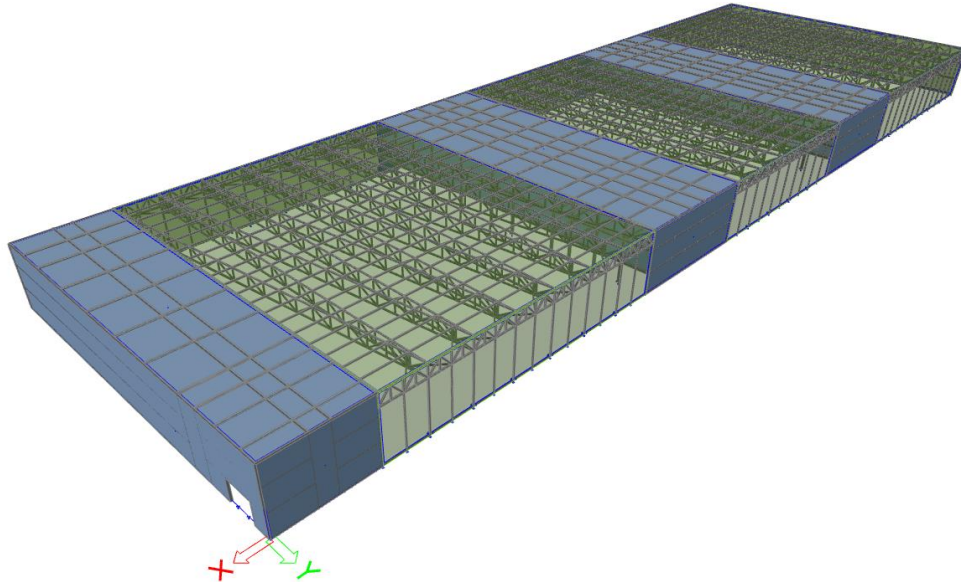

Slika 3.1. Numerički model konstrukcije

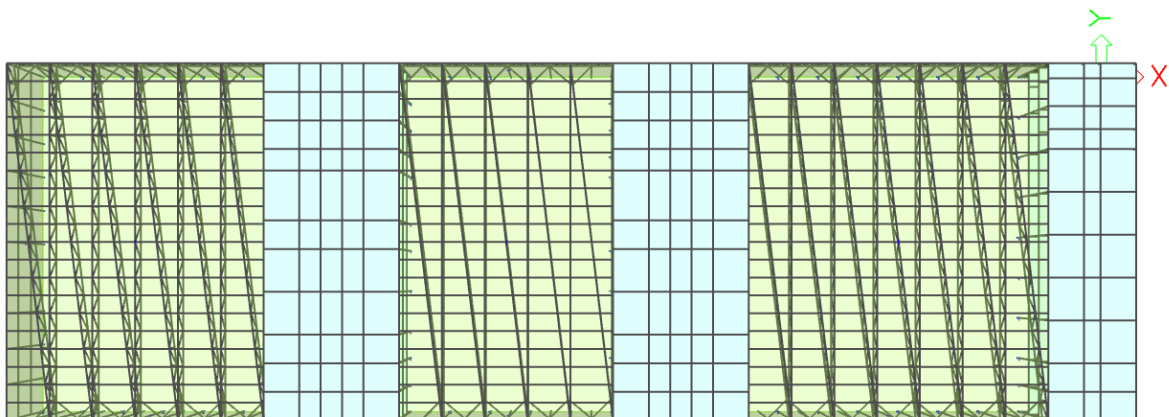

Slika 3.2. Tlocrt konstrukcije

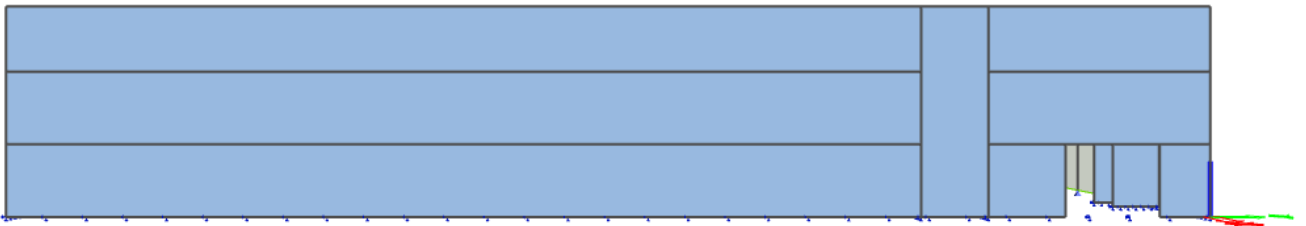

Slika 3.3. Sjeverno pročelje

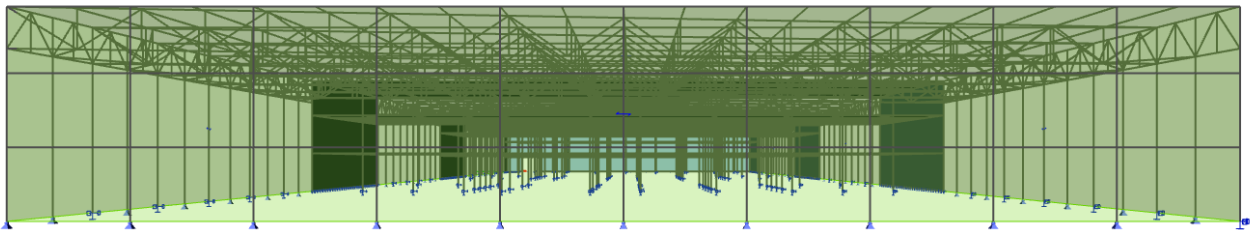

Slika 3.4. Južno pročelje



Slika 3.5. Zapadno pročelje

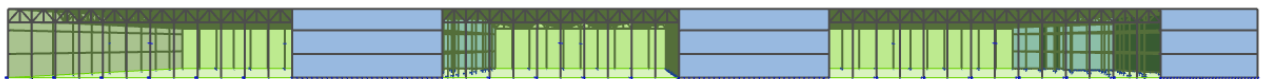

Slika 3.6. Istočno pročelje

4. Analiza opterećenja

4.1. Stalno opterećenje – vlastita težina

Vlastita težina uračunata je u sklopu numeričkog modela u software-u SCIA Engineer 19.1.

4.2. Dodatno stalno opterećenje

a) krov (betonski segmenti):

- pokrov 0,10 kN/m²
- instalacije 0,10 kN/m²
- hidroizolacija + parna brana 0,20 kN/m²
- estrih 2,50 kN/m²
- toplinska izolacija 0,20 kN/m²

Ukupno dodatno stalno opterećenje: $g_{\text{beton,krov}}=3,10 \text{ kN/m}^2$

Krov (čelični segmenti):

- fotovoltaići 0,20 kN/m²
- instalacije 0,20 kN/m²
- hidroizolacija 0,20 kN/m²
- toplinska izolacija 0,20 kN/m²

Ukupno dodatno stalno opterećenje: $g_{\text{čelik,krov}}=0,80 \text{ kN/m}^2$

b) pozicija 200

- instalacije + podno grijanje 0,10 kN/m²
- toplinska izolacija 0,20 kN/m²
- završna obrada poda - pločice 0,30 kN/m²
- hidroizolacija 0,10 kN/m²
- estrih 2,00 kN/m²
- pregrade 1,00 kN/m²

Ukupno dodatno stalno opterećenje: $g_{200}=3,70 \text{ kN/m}^2$

c) pozicija 100

- instalacije + podno grijanje 0,10 kN/m²
- toplinska izolacija 0,40 kN/m²
- završna obrada poda - pločice 0,30 kN/m²
- hidroizolacija 0,10 kN/m²
- estrih 2,00 kN/m²
- pregrade 1,00 kN/m²

Ukupno dodatno stalno opterećenje: $g_{100}=3,90 \text{ kN/m}^2$

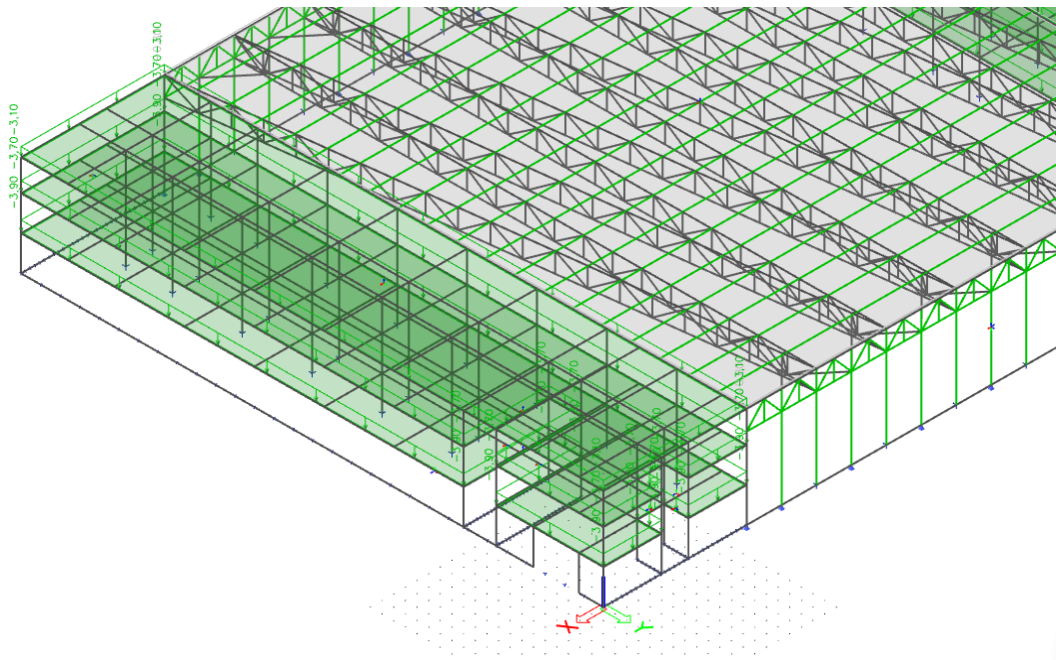

Slika 4.2.1. Dodatno stalno opterećenje, detalj

4.3. Korisno opterećenje

Kategorija	Prostor	EC1 q_k (kN/m ²)	Q_k (kN)
A	- sobe	2.0	2.0
	- stubišta	3.0	2.0
	- balkoni	4.0	2.0
B	- uredski prostori	3.0	2.0
C	C_1 – prostorije sa stolovima u školama, kavanama, restoranima, blagovaonicama, knjižnicama, recepcijama	3.0	4.0
	C_2 – prostorije s nepomičnim stolicama u crkvama, kazalištima ili kinima, sobe za sastanke, dvorane za predavanja, čekaonice	4.0	4.0
	C_3 – prostorije bez prepreka za kretanje ljudi u muzejima, izložbenim prostorima, pristupi u javnim i administrativnim zgradama, hotelima i sl.	5.0	4.0
	C_4 – športske prostorije i prostori za igru npr. plesne dvorane, gimnastičke dvorane, pozornice i sl.	5.0	7.0
	C_5 – prostorije za velika okupljanja ljudi, zgrade za javne priredbe, koncertne dvorane, športske dvorane s gledalištem, terase.	5.0	4.0
D	D_1 – prostorije u trgovinama	5.0	4.0
	D_2 – prostorije u robnim kućama i trgovinama na veliko, papirnicama	5.0	7.0
E	E - skladišta uključujući knjižnice	6.0	7.0

Slika 4.3.1. Vrijednosti korisnog djelovanja u zgradama

Za poziciju 200: uredski prostori / prostorije sa stolovima u školama, kavanama, restoranima, blagovaonicama, knjižnicama, recepcijama => 3,00 kN/m²

Za poziciju 100: prostorije sa nepomičnim sjedalima, kina prodavaonice, čekaonice, konferencijske dvorane => 4,00 kN/m²

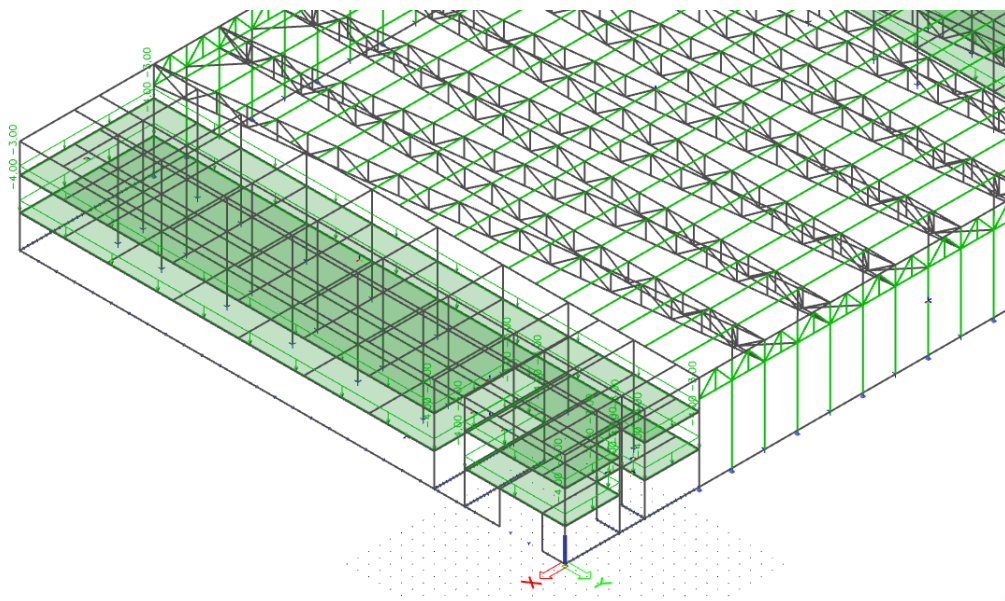

Slika 4.3.1. Korisno opterećenje, detalj

4.4. Opterećenje snijegom

Opterećenje snijegom na krovu

$$s = \mu_1 \cdot C_e \cdot C_t \cdot s_k$$

μ - koeficijent oblika opterećenja snijegom

C_e - koeficijent izloženosti (obično se usvaja kao 1,0)

C_t - toplinski koeficijent (obično se usvaja kao 1,0)

s_k - karakteristična vrijednost opterećenja snijegom na tlu

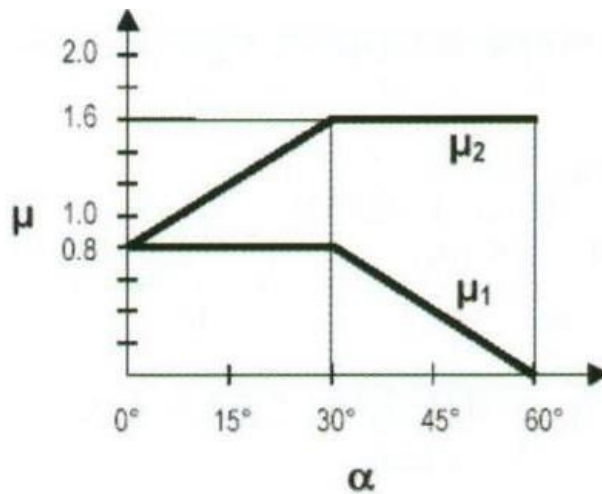

Slika 3.2. Koeficijenti oblika opterećenja snijegom

- za krov nagiba $\alpha=0^\circ$ očitana je vrijednost $\mu_1=0,8$

Prema karti snijega za Republiku Hrvatsku ova građevina spada u 3. područje – kontinentalna Hrvatska, te je prema nadmorskoj visini očitana vrijednost s_k (karakteristična vrijednost opterećenja snijegom na tlu) $\Rightarrow s_k = 0,80 \text{ kN/m}^2$



Slika 4.4.1. Karta snježnih područja za Republiku Hrvatsku

Nadmorska visina do [m]	1. područje – priobalje i otoci [kN/m ²]	2. područje – zaleđe Dalmacije, Primorja i Istre [kN/m ²]	3. područje – kontinentalna Hrvatska [kN/m ²]	4. područje – gorska Hrvatska [kN/m ²]
100	0,50	0,75	1,00	1,25
200	0,50	0,75	1,25	1,50
300	0,50	0,75	1,50	1,75
400	0,50	1,00	1,75	2,00
500	0,50	1,25	2,00	2,50
600	0,50	1,50	2,25	3,00
700	0,50	2,00	2,50	3,50
800	0,50	2,50	2,75	4,00
900	1,00	3,00	3,00	4,50
1 000	2,00	4,00	3,50	5,00
1 100	3,00	5,00	4,00	5,50
1 200	4,00	6,00	4,50	6,00
1 300	5,00	7,00		7,00
1 400	6,00	8,00		8,00
1 500		9,00		9,00
1 600		10,00		10,00
1 700		11,00		11,00
1 800		12,00		

Slika 4.4.2. Karakteristične vrijednosti opterećenja snijegom za pojedina područja i nadmorske visine

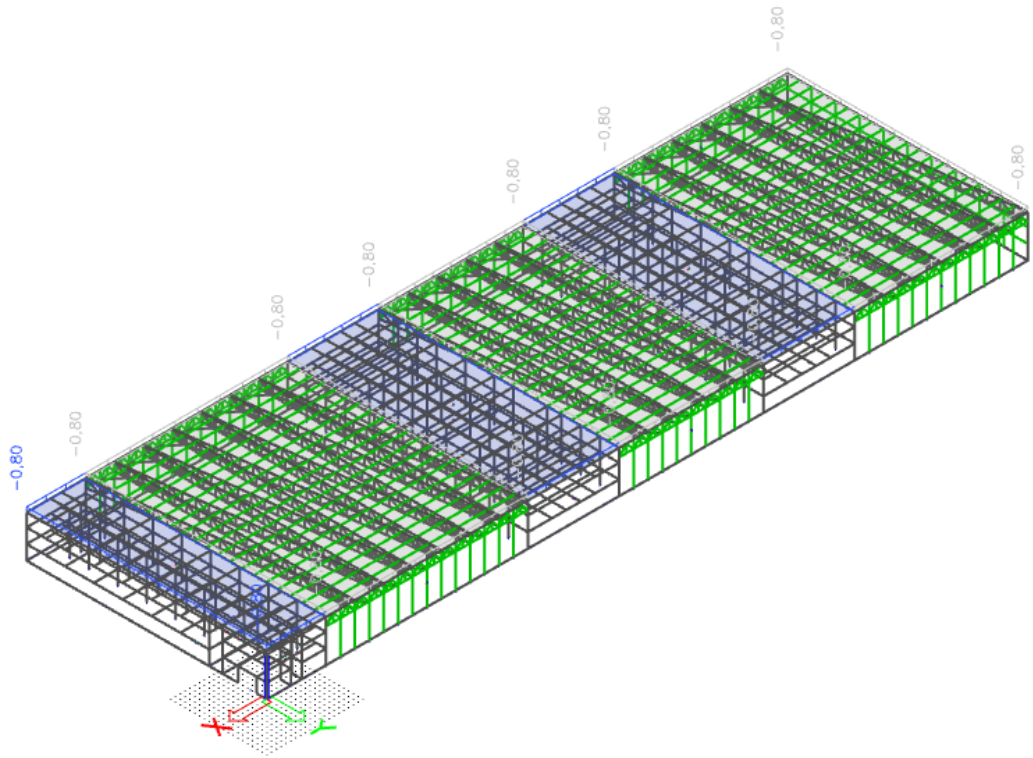

Slika 4.4.1. Opterećenje snijegom

4.5. Opterećenje vjetrom

Opterećenje vjetrom je generirano računalnim programom SCIA Engineer 19.1. pomoću značajke 3D Wind Generator. Posebno su definirane kategorija terena i početna brzina vjetra kao ulazni parametri. Također, nanoseni su paneli na čelične dijelove i vjetar se generirao na panelima i 2D vertikalnim armirano betonskim zidovima s odgovarajućim koeficijentima i proračunatim zonama.

Ispod su prikazane slike pomoću kojih je odabrana početna brzina vjetra, kao i kategorija terena. U nastavku slijedi izvješće proračuna.

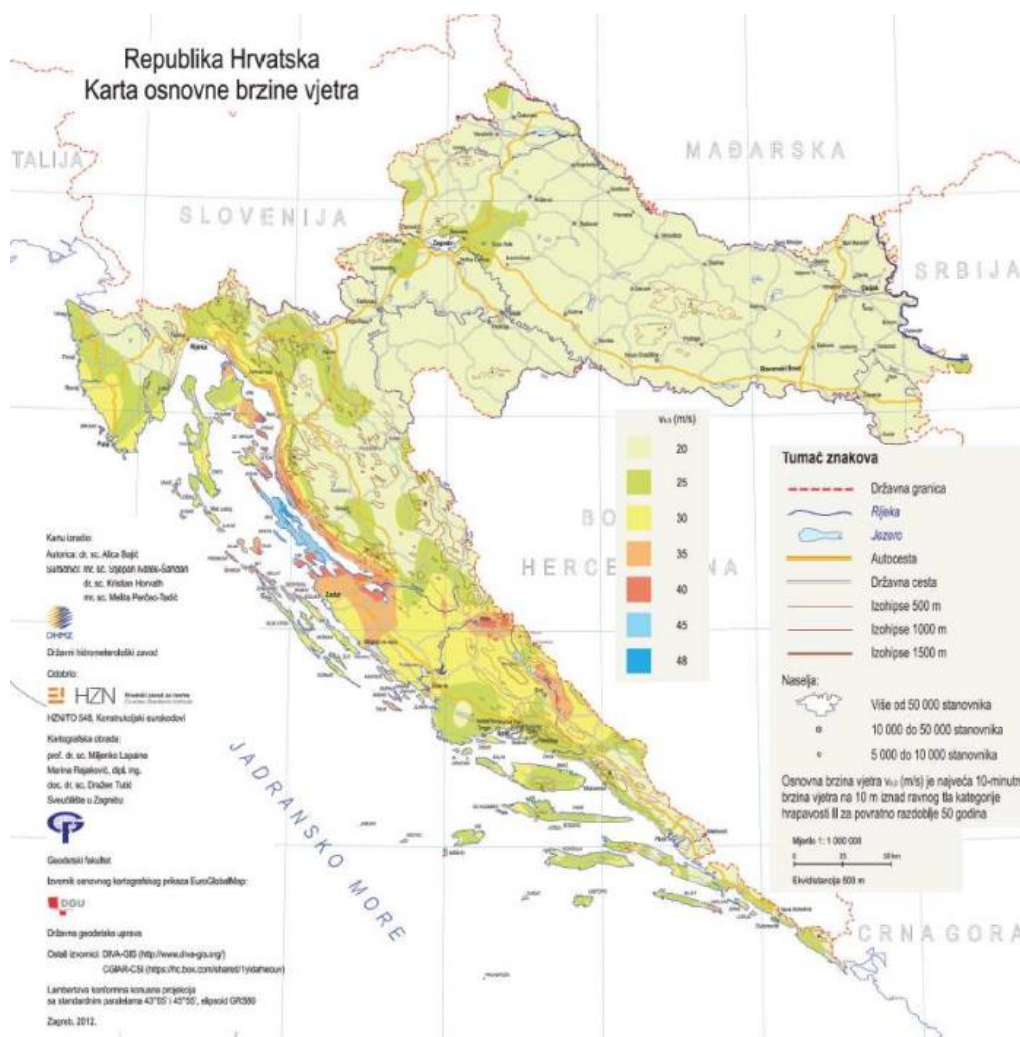

Slika 4.5.1. Karta osnovnih brzina vjetra za Republiku Hrvatsku

- Očitano: $v_b = 20,0$ (m/s) – očitano za okolicu Zagreba

Kategorija terena		z_0 [m]	z_{min} [m]
0	More ili priobalna područja izložena otvorenom moru	0,003	1
I	Ježera ili ravna i horizontalno položena područja sa zanemarivom vegetacijom i bez prepreka	0,01	1
II	Područja s niskom vegetacijom, npr. travom, i izoliranim preprekama (drveće, zgrade) s razmakom najmanje 20 visina prepreke	0,05	2
III	Područja sa stalnim pokrovom od vegetacije ili zgrade ili područja s izoliranim preprekama s razmakom najviše 20 visina prepreke (npr. sela, predgrađa, stalna šuma)	0,3	5
IV	Područja s najmanje 15 % površine pokriveno zgradama čija prosječna visina premašuje 15 m	1,0	10

Slika 4.5.2. Kategorije terena s odgovarajućim vrijednostima z_0 i z_{min}

-Odabrana kategorija terena: III

1. 3D wind generator data

Code references

National annex	Standard EN
Base code	EN 1991-1-4:2005-04
Correction sheets / Addenda	EN 1991-1-4:2005/AC:2010-01

Wind pressure according to EC1

V _{b,0} - basic wind velocity [m/s]	20,000
ρ _a - air density [kg/m ³]	1,3
c _{dir} - directional factor	1
c _{season} - season factor	1
c _o - orography factor	1
1/p - life period of the building [year]	50,00
c _{prob} - probability factor	1
K - shape factor	0.2
n - exponent	0.5
terrain category	III
K _r - terrain factor	0.215389
z ₀ - roughness length [m]	0,300
z _{min} - minimal height [m]	5,000
k _L - turbulence factor	1
Type of the structure	Vertical walls or rectangular buildings (EC1-1-4, 7.2.2)
Reference level of terrain [m]	0,000
Correlation between zones D and E	✓

Wind data

Name	2D member	Type	Roof type	Roof overhangs	Swap outer surface
WD12	S24	Wall			X
WD15	S15	Wall			✓
WD17	S8	Wall			X
WD19	S23	Wall			✓
WD20	S20	Roof	Flat	No	X
WD22	S14	Wall			X
WD24	S7	Wall			✓
WD27	S19	Wall			X
WD28	S16	Roof	Flat	No	X
WD30	S10	Roof	Flat	No	X
WD31		Roof	Flat	No	X
WD32		Wall			✓
WD33		Wall			X
WD34		Roof	Flat	No	X
WD35		Wall			✓
WD36		Wall			✓
WD37		Wall			X
WD38		Roof	Flat	No	X
WD39		Wall			✓
WD40		Wall			X

Name	2D member	Load direction	+C _{pi}	-C _{pi}	Region	Zones	+C _{pe}	-C _{pe}		
WD12	S24	0	0.2000	-0.3000	1	E	-0.3000	-0.3000		
		90	0.2000	-0.3000	1	A	-1.2000	-1.2000		
					2	B	-0.8000	-0.8000		
					3	C	-0.5000	-0.5000		
		180	0.2000	-0.3000	1	D	0.7000	0.7000		
		270	0.2000	-0.3000	1	A	-1.2000	-1.2000		
WD15	S15	0	0.2000	-0.3000	1	C	-0.5000	-0.5000		
		90	0.2000	-0.3000	1	D	0.7000	0.7000		
		180	0.2000	-0.3000	1	C	-0.5000	-0.5000		
		270	0.2000	-0.3000	1	E	-0.3000	-0.3000		
		WD17	S8	0	0.2000	-0.3000	1	C	-0.5000	-0.5000
				90	0.2000	-0.3000	1	E	-0.3000	-0.3000
180	0.2000			-0.3000	1	A	-1.2000	-1.2000		
WD19	S23	270	0.2000	-0.3000	1	B	-0.8000	-0.8000		
		0	0.2000	-0.3000	1	D	0.7000	0.7000		
		90	0.2000	-0.3000	1	C	-0.5000	-0.5000		
		180	0.2000	-0.3000	1	C	-0.5000	-0.5000		
		270	0.2000	-0.3000	1	E	-0.3000	-0.3000		
		WD20	S20	0	0.2000	-0.3000	1	I	0.2000	-0.2000
90	0.2000			-0.3000	1	G	-1.2000	-1.2000		
					2	H	-0.7000	0.7000		
					3	I	0.2000	-0.2000		
180	0.2000			-0.3000	1	I	0.2000	-0.2000		
270	0.2000			-0.3000	1	G	-1.2000	-1.2000		
			2	H	-0.7000	-0.7000				

Name	2D member	Load direction	+Cpi	-Cpi	Region	Zones	+Cpe	-Cpe
WD22	S14	0	0.2000	-0.3000	3	I	0.2000	-0.2000
		90	0.2000	-0.3000	1	C	-0.5000	-0.5000
		180	0.2000	-0.3000	1	E	-0.3000	-0.3000
		270	0.2000	-0.3000	1	C	-0.5000	-0.5000
WD24	S7	0	0.2000	-0.3000	1	D	0.7000	0.7000
		90	0.2000	-0.3000	1	C	-0.5000	-0.5000
		180	0.2000	-0.3000	1	D	0.7000	0.7000
		270	0.2000	-0.3000	1	A	-1.2000	-1.2000
					2	B	-0.8000	-0.8000
WD27	S19	0	0.2000	-0.3000	1	E	-0.3000	-0.3000
		90	0.2000	-0.3000	1	C	-0.5000	-0.5000
		180	0.2000	-0.3000	1	C	-0.5000	-0.5000
		270	0.2000	-0.3000	1	D	0.7000	0.7000
WD28	S16	0	0.2000	-0.3000	1	I	0.2000	-0.2000
		90	0.2000	-0.3000	1	G	-1.2000	-1.2000
					2	H	-0.7000	-0.7000
					3	I	0.2000	-0.2000
		180	0.2000	-0.3000	1	I	0.2000	-0.2000
		270	0.2000	-0.3000	1	G	-1.2000	-1.2000
WD30	S10	0	0.2000	-0.3000	1	I	0.2000	-0.2000
		90	0.2000	-0.3000	1	F2	-1.8000	-1.8000
					2	G	-1.2000	-1.2000
					3	H	-0.7000	-0.7000
					4	I	0.2000	-0.2000
		180	0.2000	-0.3000	1	F1	-1.8000	-1.8000
					2	F2	-1.8000	-1.8000
					3	G	-1.2000	-1.2000
					4	H	-0.7000	-0.7000
					5	I	0.2000	-0.2000
		270	0.2000	-0.3000	1	F1	-1.8000	-1.8000
					2	G	-1.2000	-1.2000
WD31	0	0	0.2000	-0.3000	1	F1	-1.8000	-1.8000
					2	F2	-1.8000	-1.8000
					3	G	-1.2000	-1.2000
					4	H	-0.7000	-0.7000
					5	I	0.2000	-0.2000
		90	0.2000	-0.3000	1	F1	-1.8000	-1.8000
					2	G	-1.2000	-1.2000
					3	H	-0.7000	-0.7000
					4	I	0.2000	-0.2000
		180	0.2000	-0.3000	1	I	0.2000	-0.2000
		270	0.2000	-0.3000	1	F2	-1.8000	-1.8000
					2	G	-1.2000	-1.2000
WD32	0	0	0.2000	-0.3000	1	A	-1.2000	-1.2000
					2	B	-0.8000	-0.8000
					3	C	-0.5000	-0.5000
		90	0.2000	-0.3000	1	D	0.7000	0.7000
		180	0.2000	-0.3000	1	C	-0.5000	-0.5000
WD33	0	0	0.2000	-0.3000	1	E	-0.3000	-0.3000
		90	0.2000	-0.3000	1	C	-0.5000	-0.5000
		180	0.2000	-0.3000	1	E	-0.3000	-0.3000
WD34	0	0	0.2000	-0.3000	1	C	-0.5000	-0.5000
		90	0.2000	-0.3000	1	D	0.7000	0.7000
		270	0.2000	-0.3000	1	I	0.2000	-0.2000
WD35	0	0	0.2000	-0.3000	1	G	-1.2000	-1.2000
					2	H	-0.7000	-0.7000
					3	I	0.2000	-0.2000
		90	0.2000	-0.3000	1	I	0.2000	-0.2000
		180	0.2000	-0.3000	1	G	-1.2000	-1.2000
		270	0.2000	-0.3000	1	H	-0.7000	-0.7000
WD36	0	0	0.2000	-0.3000	1	I	0.2000	-0.2000
					2	H	-0.7000	-0.7000
					3	I	0.2000	-0.2000
		90	0.2000	-0.3000	1	C	-0.5000	-0.5000
		180	0.2000	-0.3000	1	D	0.7000	0.7000
WD36	0	0	0.2000	-0.3000	1	B	-0.8000	-0.8000
					2	C	-0.5000	-0.5000
					3	C	-0.5000	-0.5000
		90	0.2000	-0.3000	1	E	-0.3000	-0.3000
WD36	0	0	0.2000	-0.3000	1	D	0.7000	0.7000
					2	A	-1.2000	-1.2000
					3	B	-0.8000	-0.8000
WD36	0	0	0.2000	-0.3000	1	C	-0.5000	-0.5000
					3	C	-0.5000	-0.5000

Name	2D member	Load direction	+Cpi	-Cpi	Region	Zones	+Cpe	-Cpe
WD37		180	0.2000	-0.3000	1	E	-0.3000	-0.3000
		270	0.2000	-0.3000	1	A	-1.2000	-1.2000
					2	B	-0.8000	-0.8000
					3	C	-0.5000	-0.5000
		0	0.2000	-0.3000	1	C	-0.5000	-0.5000
		90	0.2000	-0.3000	1	E	-0.3000	-0.3000
WD38		180	0.2000	-0.3000	1	B	-0.8000	-0.8000
					2	C	-0.5000	-0.5000
		270	0.2000	-0.3000	1	D	0.7000	0.7000
		0	0.2000	-0.3000	1	I	0.2000	-0.2000
		90	0.2000	-0.3000	1	G	-1.2000	-1.2000
					2	H	-0.7000	-0.7000
WD39					3	I	0.2000	-0.2000
		180	0.2000	-0.3000	1	I	0.2000	-0.2000
		270	0.2000	-0.3000	1	G	-1.2000	-1.2000
					2	H	-0.7000	-0.7000
					3	I	0.2000	-0.2000
		0	0.2000	-0.3000	1	C	-0.5000	-0.5000
WD40		90	0.2000	-0.3000	1	D	0.7000	0.7000
		180	0.2000	-0.3000	1	C	-0.5000	-0.5000
		270	0.2000	-0.3000	1	E	-0.3000	-0.3000
		0	0.2000	-0.3000	1	A	-1.2000	-1.2000
					2	B	-0.8000	-0.8000
					3	C	-0.5000	-0.5000
			1	E	-0.3000	-0.3000		
			1	C	-0.5000	-0.5000		
			1	D	0.7000	0.7000		

Student version

Student version

4.6. Temperaturno djelovanje

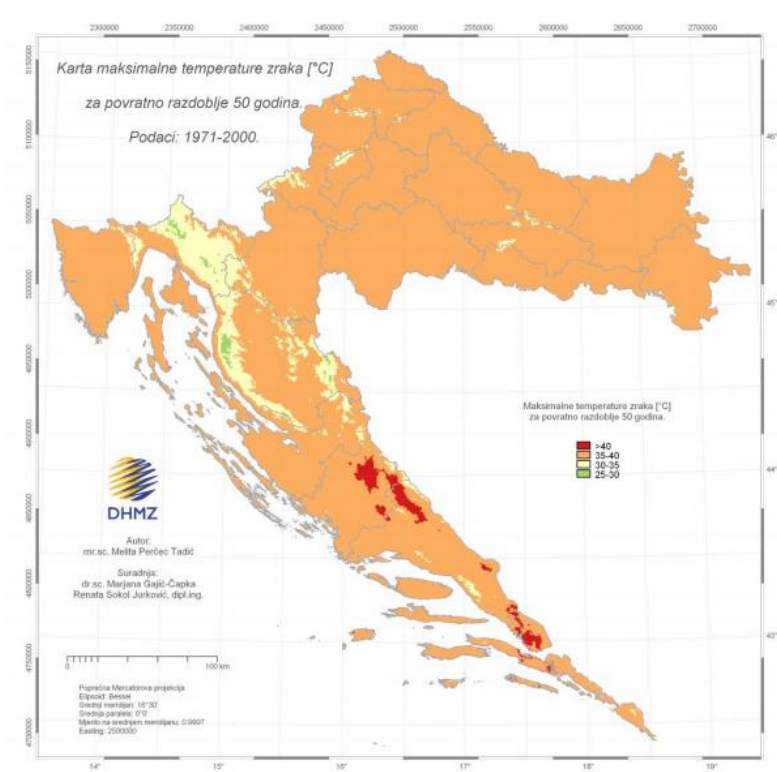

Slika 4.6.1. Karta maksimalnih temperatura zraka u RH

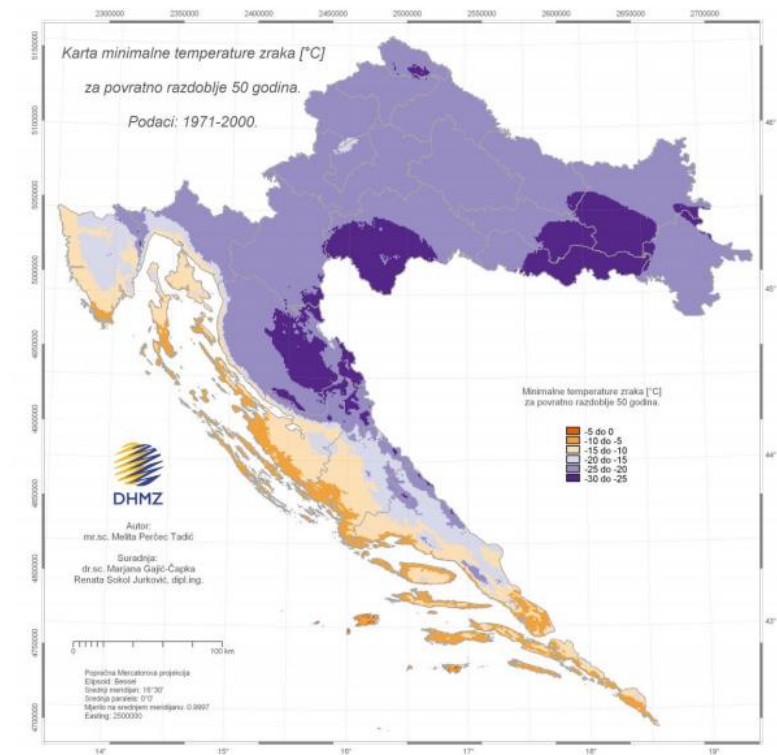

Slika 4.6.2. Karta minimalnih temperatura zraka u RH

Za područje Zagreba očitane su vrijednosti:

Najviše temperature zraka:

$$T_{\max} = 40 \text{ }^{\circ}\text{C}$$

Najniže temperature zraka:

$$T_{\min} = -25 \text{ }^{\circ}\text{C}$$

Pretpostavlja se djelovanje jednolike temperaturne promjene u svim presjecima.

Pretpostavljena temperatura pri montaži konstrukcije: $T = 15 \text{ }^{\circ}\text{C}$

Maksimalna pozitivna temperaturna promjena: $T_{\max} = 40 \text{ }^{\circ}\text{C} - 15 \text{ }^{\circ}\text{C} = 25 \text{ }^{\circ}\text{C}$

Maksimalna negativna temperaturna promjena: $T_{\min} = -25 \text{ }^{\circ}\text{C} - 15 \text{ }^{\circ}\text{C} = -40 \text{ }^{\circ}\text{C}$

5. Kombinacije djelovanja za GSN i GSU

GSN:

Combinations

Name	Type	Load cases	Coeff. [-]
<i>*Student version* *Student version* *Student version* *Student version* *Student version* *Student version* *Student version* *Student version* *Student version*</i>			
ULS-Set B (auto)	EN-ULS (STR/GEO) Set B	LC1 - Self weight	1,00
		korisno	1,00
		snijeg	1,00
		vjetar	1,00
		dodatno stalno	1,00
		3DWind1 - 0, + CPE, + CPI	1,00
		3DWind2 - 0, + CPE, - CPI	1,00
		3DWind3 - 0, - CPE, + CPI	1,00
		3DWind4 - 0, - CPE, - CPI	1,00
		3DWind5 - 90, + CPE, + CPI	1,00
		3DWind6 - 90, + CPE, - CPI	1,00
		3DWind7 - 90, - CPE, + CPI	1,00
		3DWind8 - 90, - CPE, - CPI	1,00
		3DWind9 - 180, + CPE, + CPI	1,00
		3DWind10 - 180, + CPE, - CPI	1,00
		3DWind11 - 180, - CPE, + CPI	1,00
		3DWind12 - 180, - CPE, - CPI	1,00
		3DWind13 - 270, + CPE, + CPI	1,00
		3DWind14 - 270, + CPE, - CPI	1,00
		3DWind15 - 270, - CPE, + CPI	1,00
3DWind16 - 270, - CPE, - CPI	1,00		
temperatura +	1,00		
temperatura -	1,00		
ULS-Set B (auto)1	Envelope - ultimate	LC1 - Self weight	1,35
		dodatno stalno	1,35
ULS-Set B (auto)2	Envelope - ultimate	LC1 - Self weight	1,00
		dodatno stalno	1,00
ULS-Set B (auto)3	Envelope - ultimate	LC1 - Self weight	1,35
		korisno	1,50
		snijeg	1,50
		vjetar	0,90
		dodatno stalno	1,35
		3DWind1 - 0, + CPE, + CPI	0,90
		3DWind2 - 0, + CPE, - CPI	0,90
		3DWind3 - 0, - CPE, + CPI	0,90
		3DWind4 - 0, - CPE, - CPI	0,90
		3DWind5 - 90, + CPE, + CPI	0,90
		3DWind6 - 90, + CPE, - CPI	0,90
		3DWind7 - 90, - CPE, + CPI	0,90
		3DWind8 - 90, - CPE, - CPI	0,90
		3DWind9 - 180, + CPE, + CPI	0,90
		3DWind10 - 180, + CPE, - CPI	0,90
		3DWind11 - 180, - CPE, + CPI	0,90
		3DWind12 - 180, - CPE, - CPI	0,90
		3DWind13 - 270, + CPE, + CPI	0,90
		3DWind14 - 270, + CPE, - CPI	0,90
		3DWind15 - 270, - CPE, + CPI	0,90
3DWind16 - 270, - CPE, - CPI	0,90		
temperatura +	0,90		
temperatura -	0,90		
ULS-Set B	Envelope	LC1 - Self weight	1,00
		korisno	1,50
		snijeg	1,50
		vjetar	0,90
		dodatno stalno	1,00
		3DWind1 - 0, + CPE, + CPI	0,90
		3DWind2 - 0, + CPE, - CPI	0,90
		3DWind3 - 0, - CPE, + CPI	0,90
		3DWind4 - 0, - CPE, - CPI	0,90
		3DWind5 - 90, + CPE, + CPI	0,90
		3DWind6 - 90, + CPE, - CPI	0,90
		3DWind7 - 90, - CPE, + CPI	0,90
		3DWind8 - 90, - CPE, - CPI	0,90
		3DWind9 - 180, + CPE, + CPI	0,90
		3DWind10 - 180, + CPE, - CPI	0,90
		3DWind11 - 180, - CPE, + CPI	0,90
		3DWind12 - 180, - CPE, - CPI	0,90
<i>*Student version* *Student version* *Student version* *Student version* *Student version* *Student version* *Student version* *Student version* *Student version*</i>			

Name	Type	Load cases	Coeff. [-]
<i>*Student version* *Student version* *Student version* *Student version* *Student version* *Student version* *Student version*</i>			
ULS-Set B	Envelope - ultimate	3DWind13 - 270, + CPE, + CPI	1,50
		3DWind14 - 270, + CPE, - CPI	1,50
		3DWind15 - 270, - CPE, + CPI	1,50
		3DWind16 - 270, - CPE, - CPI	1,50
		temperatura +	0,90
		temperatura -	0,90
		ULS-Set B (auto)8	Envelope - ultimate
korisno	1,50		
snijeg	1,50		
vjetar	0,90		
dodatno stalno	1,00		
3DWind1 - 0, + CPE, + CPI	1,50		
3DWind2 - 0, + CPE, - CPI	1,50		
3DWind3 - 0, - CPE, + CPI	1,50		
3DWind4 - 0, - CPE, - CPI	1,50		
3DWind5 - 90, + CPE, + CPI	1,50		
3DWind6 - 90, + CPE, - CPI	1,50		
3DWind7 - 90, - CPE, + CPI	1,50		
3DWind8 - 90, - CPE, - CPI	1,50		
3DWind9 - 180, + CPE, + CPI	1,50		
3DWind10 - 180, + CPE, - CPI	1,50		
3DWind11 - 180, - CPE, + CPI	1,50		
3DWind12 - 180, - CPE, - CPI	1,50		
3DWind13 - 270, + CPE, + CPI	1,50		
3DWind14 - 270, + CPE, - CPI	1,50		
3DWind15 - 270, - CPE, + CPI	1,50		
3DWind16 - 270, - CPE, - CPI	1,50		
temperatura +	0,90		
temperatura -	0,90		
ULS-Set B (auto)9	Envelope - ultimate	LC1 - Self weight	1,35
		korisno	1,50
		snijeg	1,50
		vjetar	0,90
		dodatno stalno	1,35
		3DWind1 - 0, + CPE, + CPI	0,90
		3DWind2 - 0, + CPE, - CPI	0,90
		3DWind3 - 0, - CPE, + CPI	0,90
		3DWind4 - 0, - CPE, - CPI	0,90
		3DWind5 - 90, + CPE, + CPI	0,90
		3DWind6 - 90, + CPE, - CPI	0,90
		3DWind7 - 90, - CPE, + CPI	0,90
		3DWind8 - 90, - CPE, - CPI	0,90
		3DWind9 - 180, + CPE, + CPI	0,90
		3DWind10 - 180, + CPE, - CPI	0,90
		3DWind11 - 180, - CPE, + CPI	0,90
		3DWind12 - 180, - CPE, - CPI	0,90
		3DWind13 - 270, + CPE, + CPI	0,90
		3DWind14 - 270, + CPE, - CPI	0,90
		3DWind15 - 270, - CPE, + CPI	0,90
		3DWind16 - 270, - CPE, - CPI	0,90
		temperatura +	1,50
		temperatura -	1,50
ULS-Set B	Envelope - ultimate	LC1 - Self weight	1,00
		korisno	1,50
		snijeg	1,50
		vjetar	0,90
		dodatno stalno	1,00
		3DWind1 - 0, + CPE, + CPI	0,90
		3DWind2 - 0, + CPE, - CPI	0,90
		3DWind3 - 0, - CPE, + CPI	0,90
		3DWind4 - 0, - CPE, - CPI	0,90
		3DWind5 - 90, + CPE, + CPI	0,90
		3DWind6 - 90, + CPE, - CPI	0,90
		3DWind7 - 90, - CPE, + CPI	0,90
		3DWind8 - 90, - CPE, - CPI	0,90
		3DWind9 - 180, + CPE, + CPI	0,90
		3DWind10 - 180, + CPE, - CPI	0,90
		3DWind11 - 180, - CPE, + CPI	0,90
		3DWind12 - 180, - CPE, - CPI	0,90

Student version* *Student version* *Student version* *Student version* *Student version* *Student version* *Student version

Name	Type	Load cases	Coeff. [-]
<i>*Student version* *Student version* *Student version* *Student version* *Student version* *Student version* *Student version*</i>			
Sub B	Envelope -	3DWind13 - 270, + CPE, + CPI	0,90
		3DWind14 - 270, + CPE, - CPI	0,90
		3DWind15 - 270, - CPE, + CPI	0,90
		3DWind16 - 270, - CPE, - CPI	0,90
		temperatura +	1,50
		temperatura -	1,50

Student version

GSU:

Combinations

Name	Type	Load cases	Coeff. [-]
<i>*Student version* *Student version* *Student version* *Student version* *Student version* *Student version* *Student version* *Student version* *Student version* *Student version*</i>			
SLS-Char (auto)	EN-SLS Characteristic	LC1 - Self weight	1,00
		korisno	1,00
		snijeg	1,00
		vjetar	1,00
		dodatno stalno	1,00
		3DWind1 - 0, + CPE, + CPI	1,00
		3DWind2 - 0, + CPE, - CPI	1,00
		3DWind3 - 0, - CPE, + CPI	1,00
		3DWind4 - 0, - CPE, - CPI	1,00
		3DWind5 - 90, + CPE, + CPI	1,00
		3DWind6 - 90, + CPE, - CPI	1,00
		3DWind7 - 90, - CPE, + CPI	1,00
		3DWind8 - 90, - CPE, - CPI	1,00
		3DWind9 - 180, + CPE, + CPI	1,00
		3DWind10 - 180, + CPE, - CPI	1,00
		3DWind11 - 180, - CPE, + CPI	1,00
		3DWind12 - 180, - CPE, - CPI	1,00
		3DWind13 - 270, + CPE, + CPI	1,00
		3DWind14 - 270, + CPE, - CPI	1,00
		3DWind15 - 270, - CPE, + CPI	1,00
3DWind16 - 270, - CPE, - CPI	1,00		
temperatura +	1,00		
temperatura -	1,00		
SLS-Quasi (auto)	EN-SLS Quasi-permanent	LC1 - Self weight	1,00
		korisno	1,00
		snijeg	1,00
		vjetar	1,00
		dodatno stalno	1,00
		3DWind1 - 0, + CPE, + CPI	1,00
		3DWind2 - 0, + CPE, - CPI	1,00
		3DWind3 - 0, - CPE, + CPI	1,00
		3DWind4 - 0, - CPE, - CPI	1,00
		3DWind5 - 90, + CPE, + CPI	1,00
		3DWind6 - 90, + CPE, - CPI	1,00
		3DWind7 - 90, - CPE, + CPI	1,00
		3DWind8 - 90, - CPE, - CPI	1,00
		3DWind9 - 180, + CPE, + CPI	1,00
		3DWind10 - 180, + CPE, - CPI	1,00
		3DWind11 - 180, - CPE, + CPI	1,00
		3DWind12 - 180, - CPE, - CPI	1,00
		3DWind13 - 270, + CPE, + CPI	1,00
		3DWind14 - 270, + CPE, - CPI	1,00
		3DWind15 - 270, - CPE, + CPI	1,00
3DWind16 - 270, - CPE, - CPI	1,00		
temperatura +	1,00		
temperatura -	1,00		
SLS-Char (auto)1	Envelope - serviceability	LC1 - Self weight	1,00
		dodatno stalno	1,00
<i>*Student version* *Student version* *Student version* *Student version* *Student version* *Student version* *Student version* *Student version* *Student version* *Student version*</i>			
SLS-Char (auto)2	Envelope	LC1 - Self weight	1,00
		korisno	1,00
		snijeg	1,00
		vjetar	0,60
		dodatno stalno	1,00
		3DWind1 - 0, + CPE, + CPI	0,60
		3DWind2 - 0, + CPE, - CPI	0,60
		3DWind3 - 0, - CPE, + CPI	0,60
		3DWind4 - 0, - CPE, - CPI	0,60
		3DWind5 - 90, + CPE, + CPI	0,60
		3DWind6 - 90, + CPE, - CPI	0,60
		3DWind7 - 90, - CPE, + CPI	0,60
		3DWind8 - 90, - CPE, - CPI	0,60
		3DWind9 - 180, + CPE, + CPI	0,60
		3DWind10 - 180, + CPE, - CPI	0,60
3DWind11 - 180, - CPE, + CPI	0,60		
3DWind12 - 180, - CPE, - CPI	0,60		
3DWind13 - 270, + CPE, + CPI	0,60		
3DWind14 - 270, + CPE, - CPI	0,60		

6. Kontrola pomaka – Granično stanje uporabljivosti (GSU)

6.1. Horizontalni pomaci

1D deformations
Values: u_x
Linear calculation
Combination: SLS-Char (auto)
Coordinate system: Global
Extreme 1D: Global
Selection: All

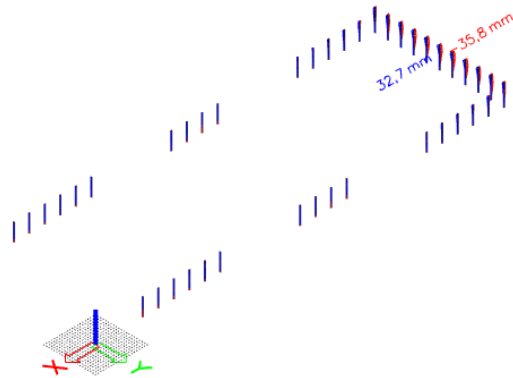

Slika 6.1.1. Horizontalni pomak velikog stupa u smjeru osi x

1D deformations
Values: u_y
Linear calculation
Combination: SLS-Char (auto)
Coordinate system: Global
Extreme 1D: Global
Selection: All

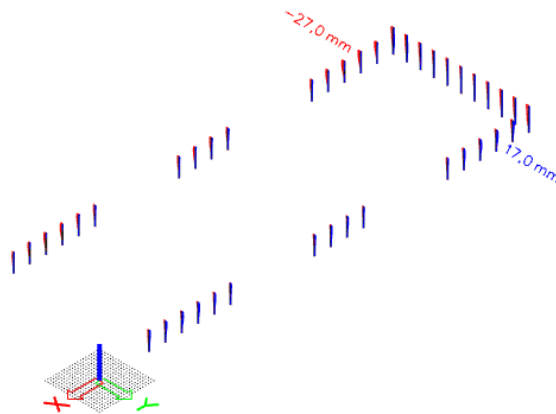

Slika 6.1.2. Horizontalni pomak velikog stupa u smjeru osi y

$U_x = 35,80 \text{ mm}$; $U_y = 27,0 \text{ mm}$

Dopušteni horizontalni pomak u smjeru x:

$$u_{x,dop} = \frac{H}{150} = \frac{7,0 \cdot 1000}{150} = 46,67 \text{ mm}$$

$$u_x = 35,80 \text{ mm} < u_{x,dop} = 46,67 \text{ mm} - \text{zadovoljava!}$$

Dopušteni horizontalni pomak u smjeru y:

$$u_{y,dop} = \frac{H}{150} = \frac{7,0 \cdot 1000}{150} = 46,67 \text{ mm}$$

$$u_y = 27,0 \text{ mm} < u_{y,dop} = 46,67 \text{ mm} - \text{zadovoljava}$$

6.2. Vertikalni progib rešetke

1D deformations
Values: uz
Linear calculation
Combination: SLS-Char (auto)
Coordinate system: Global
Extreme 1D: Global
Selection: All

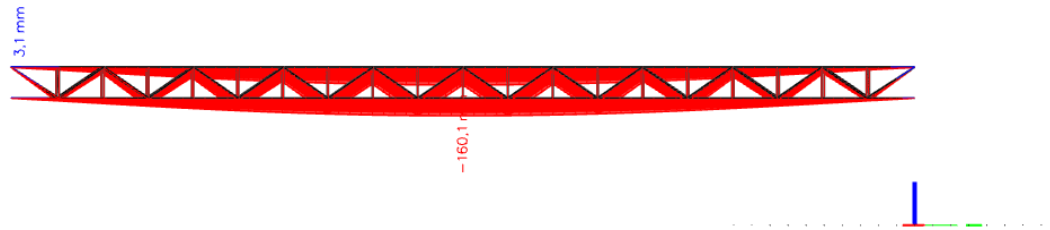

Slika 6.2.1. Vertikalni pomak rešetke u smjeru osi z

$U_z = 160,10 \text{ mm}$

Dopušteni vertikalni pomak u smjeru osi z:

$$u_{z,dop} = \frac{L}{300} = \frac{50 \cdot 1000}{300} = 166,67 \text{ mm}$$

$u_z = 160,10 \text{ mm} < u_{z,dop} = 166,67 \text{ mm} - \text{zadovoljava!}$

7. Dimenzioniranje elemenata – Granično stanje nosivosti (GSN)

7.1. Glavna rešetka

7.1.1. Gornji pojas glavne rešetke – Pozicija 1

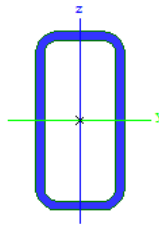
Name	GP glavna	
Type	CFRHS200X100X10	
Source description	Rautaruukki Oyj / Structural Hollow Sections EN10219 / Ed.2007	
Item material	S 355	
Fabrication	rolled	
Flexural buckling y-y	a	
Flexural buckling z-z	a	
Lateral torsional buckling	Default	
Use 2D FEM analysis	x	
		
A [m ²]	5,2570e-03	
A _{y, z} [m ²]	1,7501e-03	3,5002e-03
I _{y, z} [m ⁴]	2,4444e-05	8,1774e-06
I _w [m ⁶], I _t [m ⁴]	5,0000e-08	2,1541e-05
W _{el} y, z [m ³]	2,4444e-04	1,6355e-04
W _{pl} y, z [m ³]	3,1808e-04	1,9525e-04
d y, z [mm]	0	0
c YUCS, ZUCS [mm]	50	100
α [deg]	0,00	
A L, D [m ² /m]	5,5700e-01	1,0510e+00
M _{py} +, - [Nm]	1,13e+05	1,13e+05
M _{pz} +, - [Nm]	6,92e+04	6,92e+04

Slika 7.1.1.1. Karakteristike poprečnog presjeka gornjeg pojasa glavne rešetke

EC-EN 1993 Steel check ULS

Values: UC Overall
 Linear calculation
 Combination: ULS-Set B (auto)
 Coordinate system: Principal
 Extreme 1D: Cross-section
 Selection: All
 Filter: Cross-section = GP glavna -
 CFRHS200X100X10

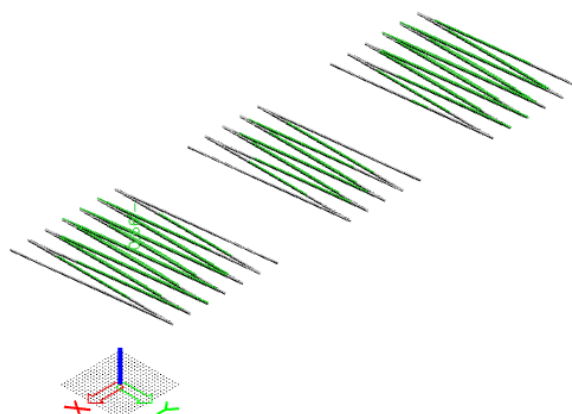

Slika 7.1.1.2. Prikaz iskoristivosti gornjeg pojasa glavne rešetke

1D internal forces

Values: M_x
Linear calculation
Combination: ULS-Set B (auto)
Coordinate system: Principal
Extreme 1D: Global
Selection: All
Filter: Cross-section = GP glavna -
CFRHS200X100X10

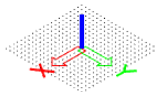
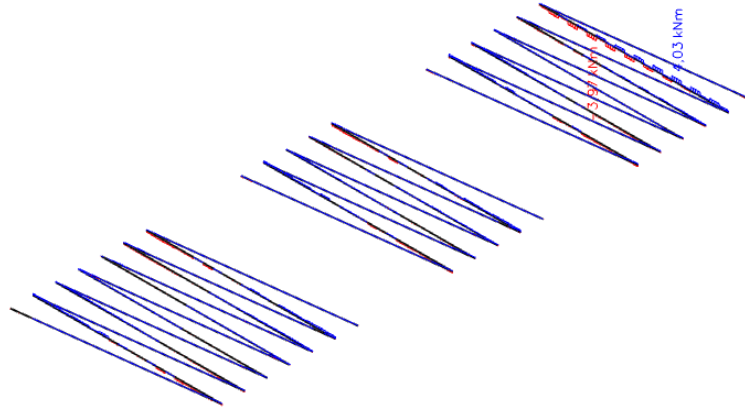

Slika 7.1.1.3.Moment M_x

1D internal forces

Values: M_y
Linear calculation
Combination: ULS-Set B (auto)
Coordinate system: Principal
Extreme 1D: Global
Selection: All
Filter: Cross-section = GP glavna -
CFRHS200X100X10

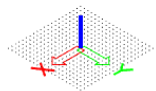
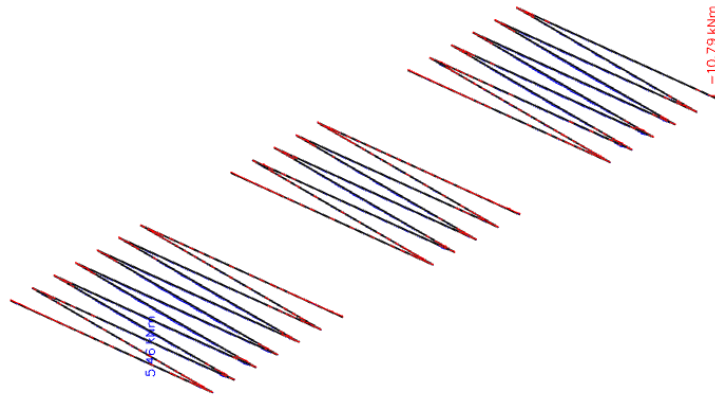

Slika 7.1.1.4.Moment M_y

1D internal forces

Values: M_z
Linear calculation
Combination: ULS-Set B (auto)
Coordinate system: Principal
Extreme 1D: Global
Selection: All
Filter: Cross-section = GP glavna -
CFRHS200X100X10

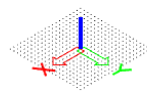
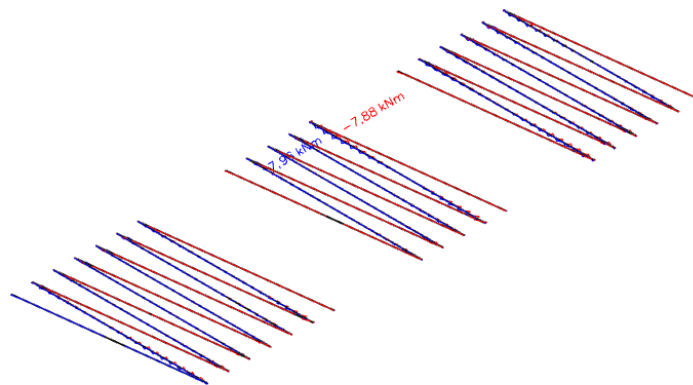

Slika 7.1.1.5.Moment M_z

1D internal forces

Values: V_y
Linear calculation
Combination: ULS-Set B (auto)
Coordinate system: Principal
Extreme 1D: Global
Selection: All
Filter: Cross-section = GP glavna - CFRHS200X100X10

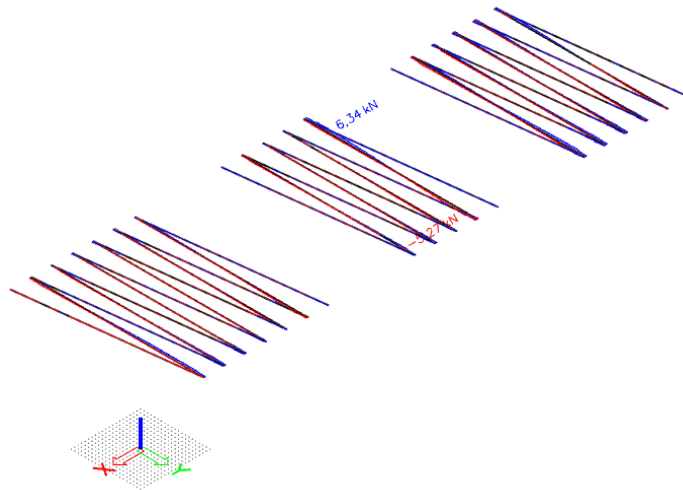

Slika 7.1.1.6. Poprečna sila V_y

1D internal forces

Values: V_z
Linear calculation
Combination: ULS-Set B (auto)
Coordinate system: Principal
Extreme 1D: Global
Selection: All
Filter: Cross-section = GP glavna - CFRHS200X100X10

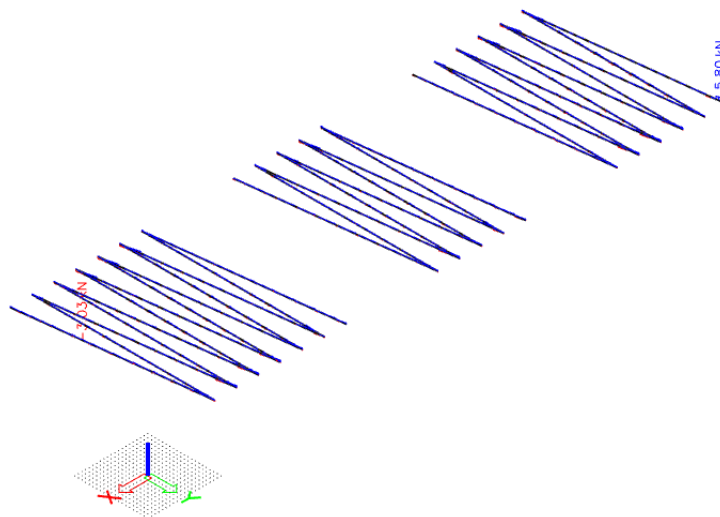

Slika 7.1.1.7. Poprečna sila V_z

1D internal forces

Values: N
Linear calculation
Combination: ULS-Set B (auto)
Coordinate system: Principal
Extreme 1D: Global
Selection: All
Filter: Cross-section = GP glavna - CFRHS200X100X10

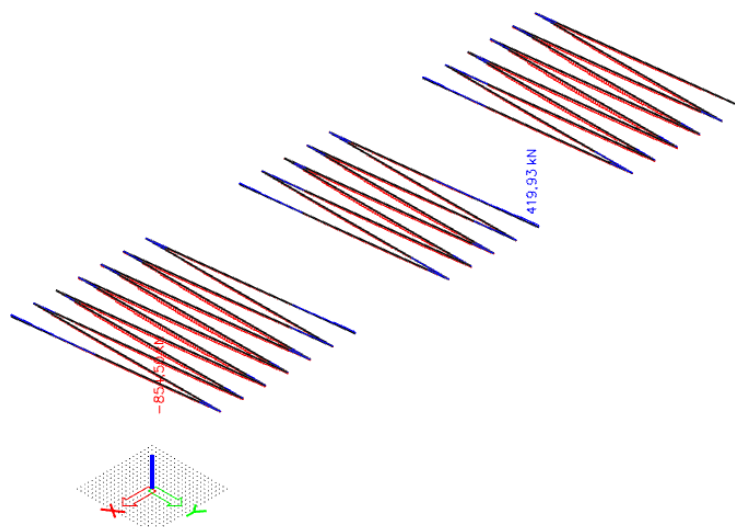

Slika 7.1.1.8. Uzdužna sila N

EC-EN 1993 Steel check ULS

Linear calculation
 Combination: ULS-Set B (auto)
 Coordinate system: Principal
 Extreme 1D: Cross-section
 Selection: All
 Filter: Cross-section = GP glavna - CFRHS200X100X10

EN 1993-1-1 Code Check

National annex: Standard EN

Member B3167	0,000 / 2,500 m	CFRHS200X100X10	S 355	ULS-Set B (auto)	0,66 -
--------------	-----------------	-----------------	-------	------------------	--------

Combination key

ULS-Set B (auto) / 1.35*LC1 + 1.50*korisno + 1.35*dodatno stalno + 1.50*3DWind2 + 0.90*temperatura -

Partial safety factors

γ_{M0} for resistance of cross-sections	1,00
γ_{M1} for resistance to instability	1,00
γ_{M2} for resistance of net sections	1,25

Material

Yield strength	f_y	355,0	MPa
Ultimate strength	f_u	490,0	MPa
Fabrication		Rolled	

....:SECTION CHECK:....

The critical check is on position 0,000 m

Internal forces		Calculated	Unit
Normal force	N_{Ed}	-854,49	kN
Shear force	$V_{y,Ed}$	-0,12	kN
Shear force	$V_{z,Ed}$	-0,25	kN
Torsion	T_{Ed}	0,13	kNm
Bending moment	$M_{y,Ed}$	5,45	kNm
Bending moment	$M_{z,Ed}$	0,16	kNm

Classification for cross-section design

Classification according to EN 1993-1-1 article 5.5.2

Classification of Internal and Outstand parts according to EN 1993-1-1 Table 5.2 Sheet 1 & 2

Id	Type	c [mm]	t [mm]	σ_1 [kN/m ²]	σ_2 [kN/m ²]	ψ [-]	k_{α} [-]	α [-]	c/t [-]	Class 1 Limit [-]	Class 2 Limit [-]	Class 3 Limit [-]	Class
1	I	70	10	1,407e+05	1,421e+05	0,99		1,00	7,00	22,78	27,66	31,02	1
3	I	170	10	1,445e+05	1,825e+05	0,79		1,00	17,00	22,78	27,66	33,32	1
5	I	70	10	1,845e+05	1,831e+05	0,99		1,00	7,00	22,78	27,66	31,00	1
7	I	170	10	1,807e+05	1,427e+05	0,79		1,00	17,00	22,78	27,66	33,35	1

Note: The Classification limits have been set according to Semi-Comp+.
 The cross-section is classified as Class 1

Compression check

According to EN 1993-1-1 article 6.2.4 and formula (6.9)

Cross-section area	A	5,2570e-03	m ²
Compression resistance	$N_{c,Rd}$	1866,24	kN
Unity check		0,46	-

Bending moment check for M_y

According to EN 1993-1-1 article 6.2.5 and formula (6.12),(6.13)

Plastic section modulus	$W_{pl,y}$	3,1808e-04	m ³
Plastic bending moment	$M_{pl,y,Rd}$	112,92	kNm
Unity check		0,05	-

Bending moment check for M_z

According to EN 1993-1-1 article 6.2.5 and formula (6.12),(6.13)

Plastic section modulus	$W_{pl,z}$	1,9525e-04	m ³
Plastic bending moment	$M_{pl,z,Rd}$	69,31	kNm
Unity check		0,00	-

Shear check for V_y

According to EN 1993-1-1 article 6.2.6 and formula (6.17)

Shear correction factor	η	1,20	
Shear area	A_w	1,7523e-03	m ²
Plastic shear resistance for V_y	$V_{pl,y,Rd}$	359,16	kN
Unity check		0,00	-

Shear check for V_z

According to EN 1993-1-1 article 6.2.6 and formula (6.17)

Shear correction factor	η	1,20	
Shear area	A_v	3,5047e-03	m ²
Plastic shear resistance for V_z	$V_{pl,z,Rd}$	718,31	kN
Unity check		0,00	-

Torsion check

According to EN 1993-1-1 article 6.2.7 and formula (6.23)

Index of fibre	Fibre	1	
Total torsional moment	T_{Ed}	0,4	MPa
Elastic shear resistance	T_{Rd}	205,0	MPa
Unity check		0,00	-

Note: The unity check for torsion is lower than the limit value of 0,05. Therefore torsion is considered as insignificant and is ignored in the combined checks.

Combined bending, axial force and shear force check

According to EN 1993-1-1 article 6.2.9.1 and formula (6.41)

Design plastic moment resistance reduced due to N_{Ed}	$M_{N,y,Rd}$	81,62	kNm
Exponent of bending ratio y	α	2,18	
Design plastic moment resistance reduced due to N_{Ed}	$M_{N,z,Rd}$	42,68	kNm
Exponent of bending ratio z	β	2,18	

Unity check (6.41) = 0,00 + 0,00 = 0,00 -

Note: Since the shear forces are less than half the plastic shear resistances their effect on the moment resistances is neglected.

The member satisfies the section check.

....:STABILITY CHECK:....

Classification for member buckling design

Decisive position for stability classification: 0,000 m

Classification according to EN 1993-1-1 article 5.5.2

Classification of Internal and Outstand parts according to EN 1993-1-1 Table 5.2 Sheet 1 & 2

Id	Type	c [mm]	t [mm]	σ_1 [kN/m ²]	σ_2 [kN/m ²]	Ψ [-]	k_σ [-]	α [-]	c/t [-]	Class 1 Limit [-]	Class 2 Limit [-]	Class 3 Limit [-]	Class
1	I	70	10	1,407e+05	1,421e+05	0,99		1,00	7,00	22,78	27,66	31,02	1
3	I	170	10	1,445e+05	1,825e+05	0,79		1,00	17,00	22,78	27,66	33,32	1
5	I	70	10	1,845e+05	1,831e+05	0,99		1,00	7,00	22,78	27,66	31,00	1
7	I	170	10	1,807e+05	1,427e+05	0,79		1,00	17,00	22,78	27,66	33,35	1

Note: The Classification limits have been set according to Semi-Comp+.

The cross-section is classified as Class 1

Flexural Buckling check

According to EN 1993-1-1 article 6.3.1.1 and formula (6.46)

Buckling parameters		yy	zz	
Sway type		sway	non-sway	
System length	L	2,500	47,500	m
Buckling factor	k	1,00	0,05	
Buckling length	l_{cr}	2,500	2,500	m
Critical Euler load	N_{cr}	8106,09	2711,78	kN
Slenderness	λ	36,66	63,39	
Relative slenderness	λ_{rel}	0,48	0,83	
Limit slenderness	$\lambda_{rel,0}$	0,20	0,20	
Buckling curve		a	a	
Imperfection	α	0,21	0,21	
Reduction factor	χ	0,93	0,78	
Buckling resistance	$N_{b,Rd}$	1736,39	1452,62	kN

Flexural Buckling verification

Cross-section area	A	5,2570e-03	m ²
Buckling resistance	$N_{b,Rd}$	1452,62	kN
Unity check		0,59	-

Torsional(-Flexural) Buckling check

According to EN 1993-1-1 article 6.3.1.1 and formula (6.46)

Note: The cross-section concerns a RHS section which is not susceptible to Torsional(-Flexural) Buckling.

Lateral Torsional Buckling check

According to EN 1993-1-1 article 6.3.2.1

Note: The cross-section concerns an RHS section with ' $h/b < 10/\lambda_{rel,z}$ '. This section is thus not susceptible to Lateral Torsional Buckling.

Bending and axial compression check

According to EN 1993-1-1 article 6.3.3 and formula (6.61),(6.52)

Bending and axial compression check parameters			
Interaction method		alternative method 1	
Cross-section area	A	5,2570e-03	m ²
Plastic section modulus	W _{pl,y}	3,1808e-04	m ³
Plastic section modulus	W _{pl,z}	1,9525e-04	m ³
Design compression force	N _{Ed}	854,49	kN
Design bending moment (maximum)	M _{y,Ed}	5,45	kNm
Design bending moment (maximum)	M _{z,Ed}	-2,76	kNm
Characteristic compression resistance	N _{Rk}	1866,24	kN
Characteristic moment resistance	M _{y,Rk}	112,92	kNm
Characteristic moment resistance	M _{z,Rk}	69,31	kNm
Reduction factor	χ _y	0,93	
Reduction factor	χ _z	0,78	
Reduction factor	χ _{LT}	1,00	
Interaction factor	k _{yy}	1,10	
Interaction factor	k _{yz}	0,57	
Interaction factor	k _{zy}	0,70	
Interaction factor	k _{zz}	0,83	

Maximum moment M_{y,Ed} is derived from beam B3167 position 0,000 m.
Maximum moment M_{z,Ed} is derived from beam B3177 position 0,000 m.

Interaction method 1 parameters			
Critical Euler load	N _{cr,y}	8106,09	kN
Critical Euler load	N _{cr,z}	2711,78	kN
Elastic critical load	N _{cr,T}	280391,41	kN
Plastic section modulus	W _{pl,y}	3,1808e-04	m ³
Elastic section modulus	W _{el,y}	2,4444e-04	m ³
Plastic section modulus	W _{pl,z}	1,9525e-04	m ³
Elastic section modulus	W _{el,z}	1,6355e-04	m ³
Second moment of area	I _y	2,4444e-05	m ⁴
Second moment of area	I _z	8,1774e-06	m ⁴
Torsional constant	I _t	2,1541e-05	m ⁴
Method for equivalent moment factor C _{my,0}		Table A.2 Line 2 (General)	
Design bending moment (maximum)	M _{y,Ed}	5,45	kNm
Maximum relative deflection	δ _z	-0,7	mm
Equivalent moment factor	C _{my,0}	1,01	
Method for equivalent moment factor C _{mz,0}		Table A.2 Line 2 (General)	
Design bending moment (maximum)	M _{z,Ed}	-2,76	kNm
Maximum relative deflection	δ _y	1,0	mm
Equivalent moment factor	C _{mz,0}	0,69	
Factor	μ _y	0,99	
Factor	μ _z	0,91	
Factor	ε _y	0,14	
Factor	α _{LT}	0,12	
Critical moment for uniform bending	M _{cr,0}	114,32	kNm
Relative slenderness	λ _{rel,0}	0,99	
Limit relative slenderness	λ _{rel,0,lim}	0,22	
Equivalent moment factor	C _{my}	1,01	
Equivalent moment factor	C _{mz}	0,69	
Equivalent moment factor	C _{mLT}	1,00	
Factor	b _{LT}	0,00	
Factor	c _{LT}	0,01	
Factor	d _{LT}	0,00	
Factor	e _{LT}	0,02	
Factor	w _y	1,30	
Factor	w _z	1,19	
Factor	η _{pl}	0,46	
Maximum relative slenderness	λ _{rel,max}	0,83	
Factor	C _{yy}	1,02	
Factor	C _{yz}	1,01	
Factor	C _{zy}	0,92	
Factor	C _{zz}	1,09	

Unity check (6.61) = 0,49 + 0,05 + 0,02 = 0,57 -

Unity check (6.62) = 0,59 + 0,03 + 0,03 = 0,66 -

The member satisfies the stability check.

7.1.2. Donji pojas glavne rešetke – Pozicija 2

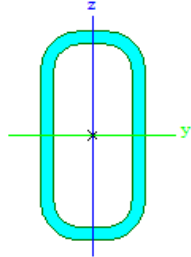
Name	DP glavna	
Type	CFRHS200X100X12.5	
Source description	Rautaruukki Oyj / Structural Hollow Sections EN10219 / Ed.2007	
Item material	S 355	
Fabrication	rolled	
Flexural buckling y-y	a	
Flexural buckling z-z	a	
Lateral torsional buckling	Default	
Use 2D FEM analysis	x	
		
A [m ²]	6,2040e-03	
A _{y, z} [m ²]	2,0640e-03	4,1280e-03
I _{y, z} [m ⁴]	2,6589e-05	8,9215e-06
I _w [m ⁶], I _t [m ⁴]	6,2500e-08	2,4738e-05
W _{el, y, z} [m ³]	2,6589e-04	1,7843e-04
W _{pl, y, z} [m ³]	3,5913e-04	2,2078e-04
d _{y, z} [mm]	0	0
c _{YUCS, ZUCS} [mm]	50	100
α [deg]	0,00	
A _{L, D} [m ² /m]	5,3600e-01	9,9220e-01
M _{pl, y, z} [Nm]	1,27e+05	1,27e+05
M _{plz, y, z} [Nm]	7,82e+04	7,82e+04

Slika 7.1.2.1. Karakteristike poprečnog presjeka donjeg pojasa glavne rešetke

EC-EN 1993 Steel check ULS

Values: UC_{Overall}
 Linear calculation
 Combination: ULS-Set B (auto)
 Coordinate system: Principal
 Extreme 1D: Cross-section
 Selection: All
 Filter: Cross-section = DP glavna -
 CFRHS200X100X12.5

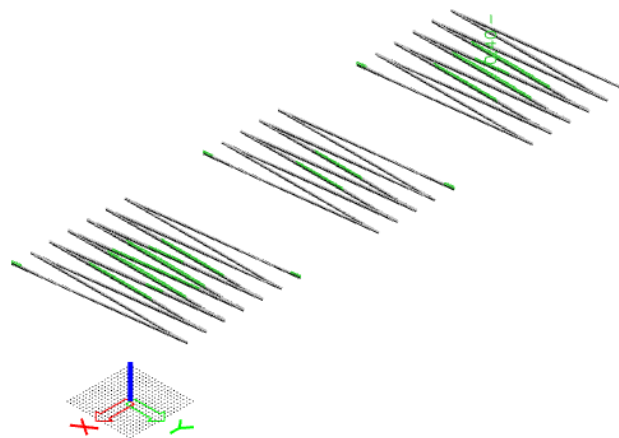

Slika 7.1.2.2. Prikaz iskoristivosti donjeg pojasa glavne rešetke

1D internal forces

Values: M_x
Linear calculation
Combination: ULS-Set B (auto)
Coordinate system: Principal
Extreme 1D: Global
Selection: All
Filter: Cross-section = DP glavna -
CFRHS200X100X12.5

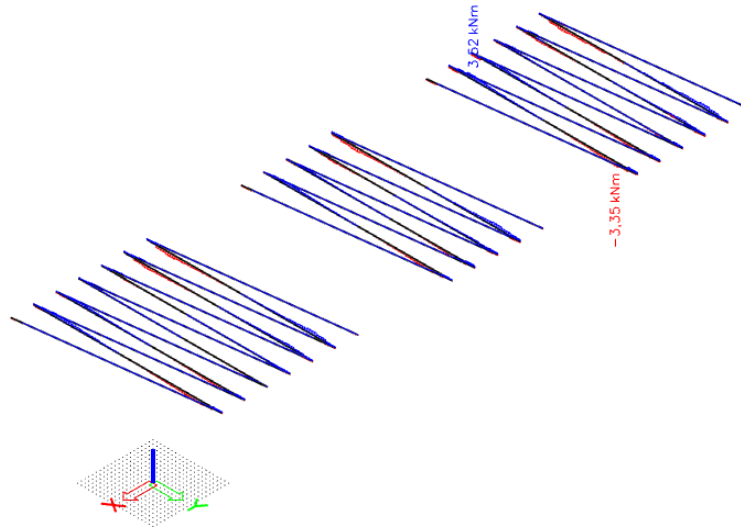

Slika 7.1.2.3.Moment M_x

1D internal forces

Values: M_y
Linear calculation
Combination: ULS-Set B (auto)
Coordinate system: Principal
Extreme 1D: Global
Selection: All
Filter: Cross-section = DP glavna -
CFRHS200X100X12.5

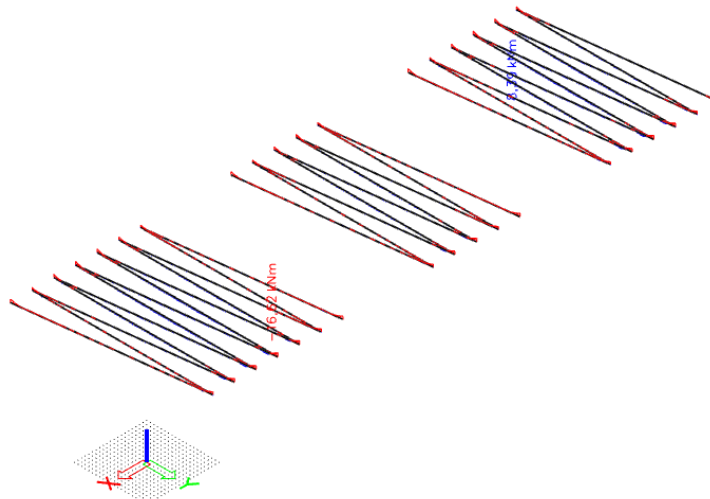

Slika 7.1.2.4.Moment M_y

1D internal forces

Values: M_z
Linear calculation
Combination: ULS-Set B (auto)
Coordinate system: Principal
Extreme 1D: Global
Selection: All
Filter: Cross-section = DP glavna -
CFRHS200X100X12.5

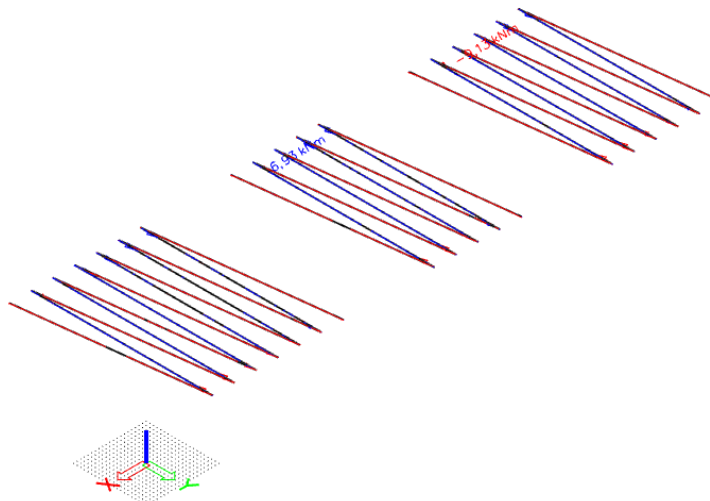

Slika 7.1.2.5.Moment M_z

1D internal forces

Values: V_y
Linear calculation
Combination: ULS-Set B (auto)
Coordinate system: Principal
Extreme 1D: Global
Selection: All
Filter: Cross-section = DP glavna -
CFRHS200X100X12.5

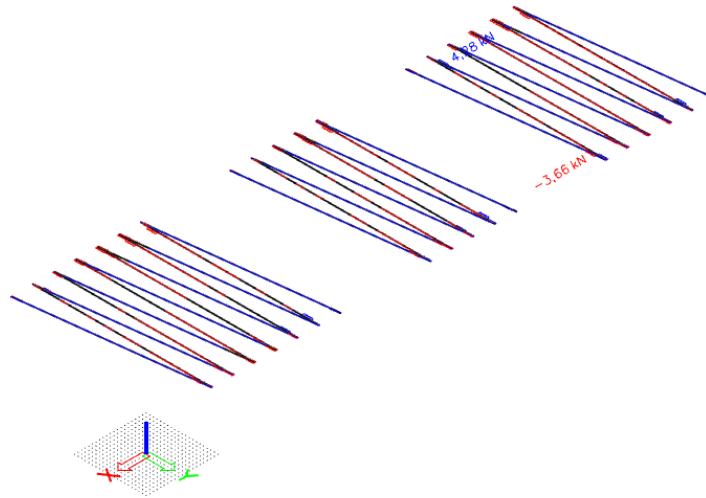

Slika 7.1.2.6. Poprečna sila V_y

1D internal forces

Values: V_z
Linear calculation
Combination: ULS-Set B (auto)
Coordinate system: Principal
Extreme 1D: Global
Selection: All
Filter: Cross-section = DP glavna -
CFRHS200X100X12.5

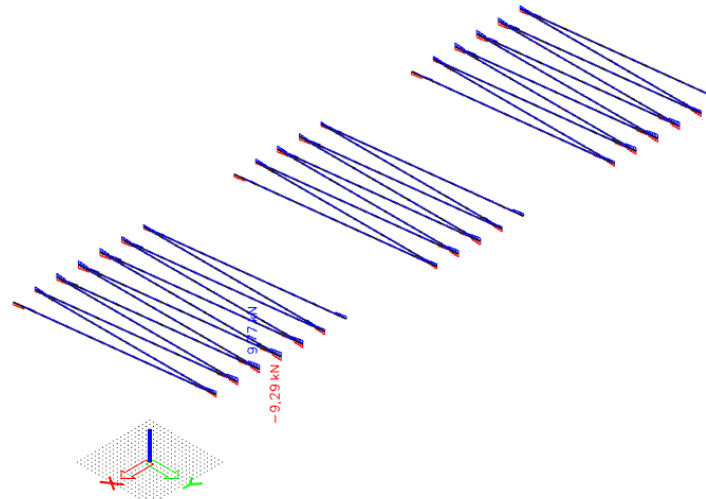

Slika 7.1.2.7. Poprečna sila V_z

1D internal forces

Values: N
Linear calculation
Combination: ULS-Set B (auto)
Coordinate system: Principal
Extreme 1D: Global
Selection: All
Filter: Cross-section = DP glavna -
CFRHS200X100X12.5

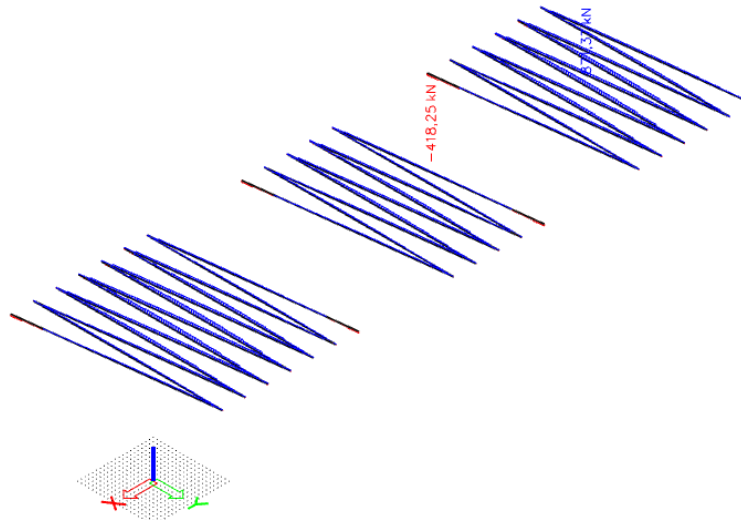

Slika 7.1.2.8. Uzdužna sila N

EC-EN 1993 Steel check ULS

Linear calculation
 Combination: ULS-Set B (auto)
 Coordinate system: Principal
 Extreme 1D: Cross-section
 Selection: All
 Filter: Cross-section = DP glavna - CFRHS200X100X12.5

EN 1993-1-1 Code Check

National annex: Standard EN

Member B4932	0,000 / 2,500 m	CFRHS200X100X12.5	S 355	ULS-Set B (auto)	0,40 -
--------------	-----------------	-------------------	-------	------------------	--------

Combination key

ULS-Set B (auto) / 1.35*LC1 + 1.50*korisno +
 1.35*dodatno stalno + 1.50*3DWind10 +
 0.90*temperatura -

Partial safety factors

γ_{M0} for resistance of cross-sections	1,00
γ_{M1} for resistance to instability	1,00
γ_{M2} for resistance of net sections	1,25

Material

Yield strength	f_y	355,0	MPa
Ultimate strength	f_u	490,0	MPa
Fabrication		Rolled	

....:SECTION CHECK:....

The critical check is on position 0,000 m

Internal forces		Calculated	Unit
Normal force	N_{Ed}	871,37	kN
Shear force	$V_{y,Ed}$	0,01	kN
Shear force	$V_{z,Ed}$	0,25	kN
Torsion	T_{Ed}	0,11	kNm
Bending moment	$M_{y,Ed}$	5,31	kNm
Bending moment	$M_{z,Ed}$	0,10	kNm

Classification for cross-section design

Classification according to EN 1993-1-1 article 5.5.2

Classification of Internal and Outstand parts according to EN 1993-1-1 Table 5.2 Sheet 1 & 2

Id	Type	c [mm]	t [mm]	σ_1 [kN/m ²]	σ_2 [kN/m ²]	ψ [-]	k_σ [-]	α [-]	c/t [-]	Class 1 Limit [-]	Class 2 Limit [-]	Class 3 Limit [-]	Class
1	I	63	13	-1,596e+05	-1,589e+05								
3	I	162	13	-1,563e+05	-1,238e+05								
5	I	63	13	-1,214e+05	-1,221e+05								
7	I	162	13	-1,248e+05	-1,572e+05								

Note: The Classification limits have been set according to Semi-Comp+.
 The cross-section is classified as Class 1

Tension check

According to EN 1993-1-1 article 6.2.3 and formula (6.5)

Cross-section area	A	6,2040e-03	m ²
Plastic tension resistance	$N_{pl,Rd}$	2202,42	kN
Ultimate tension resistance	$N_{u,Rd}$	2188,77	kN
Tension resistance	$N_{t,Rd}$	2188,77	kN
Unity check		0,40	-

Bending moment check for M_y

According to EN 1993-1-1 article 6.2.5 and formula (6.12),(6.13)

Plastic section modulus	$W_{pl,y}$	3,5913e-04	m ³
Plastic bending moment	$M_{pl,y,Rd}$	127,49	kNm
Unity check		0,04	-

Bending moment check for M_z

According to EN 1993-1-1 article 6.2.5 and formula (6.12),(6.13)

Plastic section modulus	$W_{pl,z}$	2,2078e-04	m ³
Plastic bending moment	$M_{pl,z,Rd}$	78,38	kNm
Unity check		0,00	-

Shear check for V_y

According to EN 1993-1-1 article 6.2.6 and formula (6.17)

Shear correction factor	η	1,20	
Shear area	A_w	2,0680e-03	m ²
Plastic shear resistance for V_y	$V_{pl,y,Rd}$	423,86	kN
Unity check		0,00	-

Shear check for V_z

According to EN 1993-1-1 article 6.2.6 and formula (6.17)

Shear correction factor	η	1,20	
Shear area	A_w	4,1360e-03	m ²
Plastic shear resistance for V_z	$V_{pl,z,Rd}$	847,71	kN
Unity check		0,00	-

Torsion check

According to EN 1993-1-1 article 6.2.7 and formula (6.23)

Index of fibre	Fibre	1	
Total torsional moment	T_{Ed}	0,3	MPa
Elastic shear resistance	T_{Rd}	205,0	MPa
Unity check		0,00	-

Note: The unity check for torsion is lower than the limit value of 0,05. Therefore torsion is considered as insignificant and is ignored in the combined checks.

Combined bending, axial force and shear force check

According to EN 1993-1-1 article 6.2.9.1 and formula (6.41)

Design plastic moment resistance reduced due to N_{Ed}	$M_{N,y,Rd}$	102,73	kNm
Exponent of bending ratio y	α	2,02	
Design plastic moment resistance reduced due to N_{Ed}	$M_{N,z,Rd}$	52,46	kNm
Exponent of bending ratio z	β	2,02	

Unity check (6.41) = 0,00 + 0,00 = 0,00 -

Note: Since the shear forces are less than half the plastic shear resistances their effect on the moment resistances is neglected.

The member satisfies the section check.

....:STABILITY CHECK:....

Classification for member buckling design

Decisive position for stability classification: 0,000 m

Classification according to EN 1993-1-1 article 5.5.2

Classification of Internal and Outstand parts according to EN 1993-1-1 Table 5.2 Sheet 1 & 2

Id	Type	c [mm]	t [mm]	σ_1 [kN/m ²]	σ_2 [kN/m ²]	Ψ [-]	k_σ [-]	α [-]	c/t [-]	Class 1 Limit [-]	Class 2 Limit [-]	Class 3 Limit [-]	Class [-]
1	I	63	13	-1,595e+05	-1,589e+05								
3	I	162	13	-1,563e+05	-1,238e+05								
5	I	63	13	-1,214e+05	-1,221e+05								
7	I	162	13	-1,248e+05	-1,572e+05								

Note: The Classification limits have been set according to Semi-Comp+. The cross-section is classified as Class 1

Lateral Torsional Buckling check

According to EN 1993-1-1 article 6.3.2.1

Note: The cross-section concerns an RHS section with 'h / b < 10 / $\lambda_{rel,z}$ '. This section is thus not susceptible to Lateral Torsional Buckling.

The member satisfies the stability check.

Student version

7.1.3. Ispune glavne rešetke – Pozicija 3

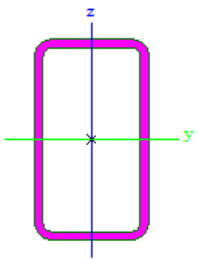
Name	ispune glavna		
Type	CFRHS140X80X6		
Source description	Rautaruukki Oyj / Structural Hollow Sections EN10219 / Ed.2007		
Item material	S 355		
Fabrication	rolled		
Flexural buckling y-y	a		
Flexural buckling z-z	a		
Lateral torsional buckling	Default		
Use 2D FEM analysis	x		
			
A [m ²]	2,4030e-03		
A _{y, z} [m ²]	8,7330e-04		1,5283e-03
I _{y, z} [m ⁴]	5,9700e-06		2,4796e-06
I _w [m ⁶], t [m ⁴]	6,8992e-09		5,8380e-06
W _{el} y, z [m ³]	8,5290e-05		6,1990e-05
W _{pl} y, z [m ³]	1,0709e-04		7,2430e-05
d y, z [mm]	0		0
c YUCS, ZUCS [mm]	40		70
α [deg]	0,00		
A L, D [m ² /m]	4,1900e-01		8,0095e-01
M _{pl} +, - [Nm]	3,80e+04		3,80e+04
M _{plz} +, - [Nm]	2,57e+04		2,57e+04

Slika 7.1.3.1. Karakteristike poprečnog presjeka ispuna glavne rešetke

EC-EN 1993 Steel check ULS

Values: UC Overall

Linear calculation

Combination: ULS-Set B (auto)

Coordinate system: Principal

Extreme 1D: Cross-section

Selection: All

Filter: Cross-section = ispune glavna -

CFRHS140X80X6

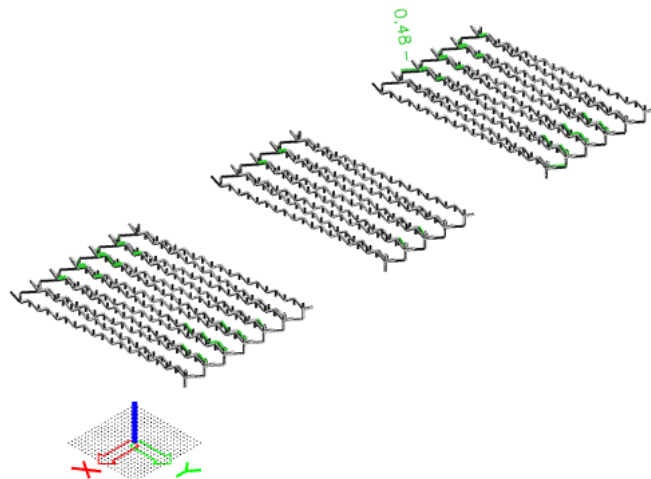

Slika 7.1.3.2. Prikaz iskoristivosti ispuna glavne rešetke

1D internal forces

Values: M_x
Linear calculation
Combination: ULS-Set B (auto)
Coordinate system: Principal
Extreme 1D: Global
Selection: All
Filter: Cross-section = ispune glavna - CFRHS140X80X6

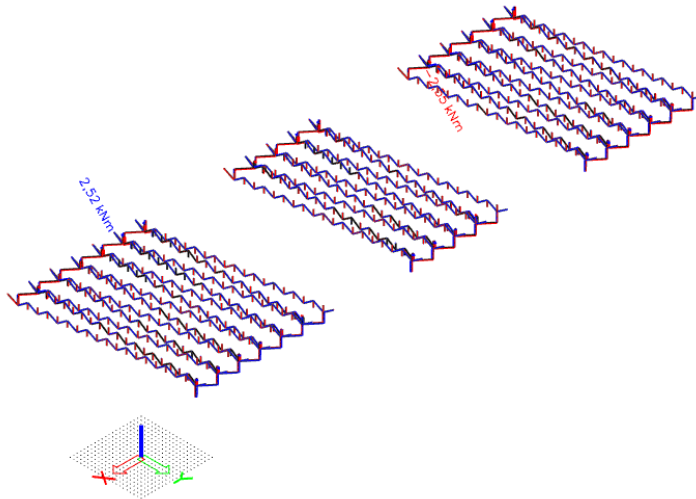

Slika 7.1.3.3. Moment M_x

1D internal forces

Values: M_y
Linear calculation
Combination: ULS-Set B (auto)
Coordinate system: Principal
Extreme 1D: Global
Selection: All
Filter: Cross-section = ispune glavna - CFRHS140X80X6

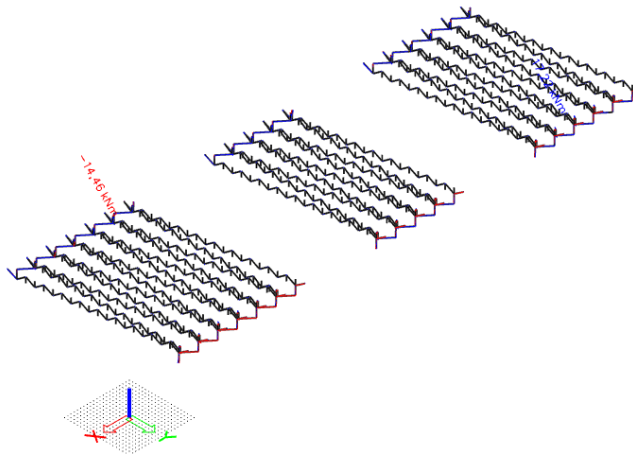

Slika 7.1.3.4. Moment M_y

1D internal forces

Values: M_z
Linear calculation
Combination: ULS-Set B (auto)
Coordinate system: Principal
Extreme 1D: Global
Selection: All
Filter: Cross-section = ispune glavna - CFRHS140X80X6

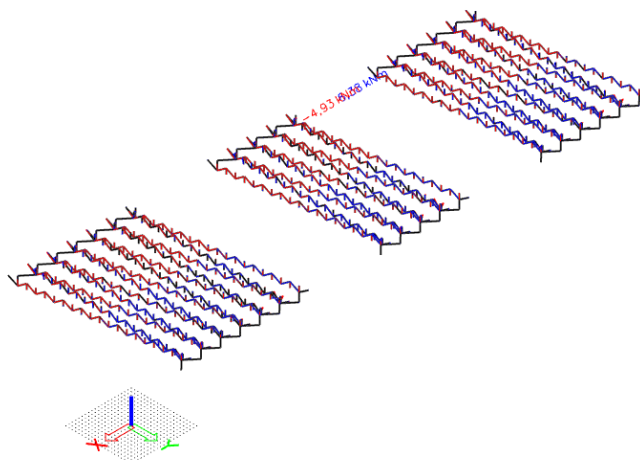

Slika 7.1.3.5. Moment M_z

1D internal forces

Values: V_y
Linear calculation
Combination: ULS-Set B (auto)
Coordinate system: Principal
Extreme 1D: Global
Selection: All
Filter: Cross-section = ispunje glavna - CFRHS140X80X6

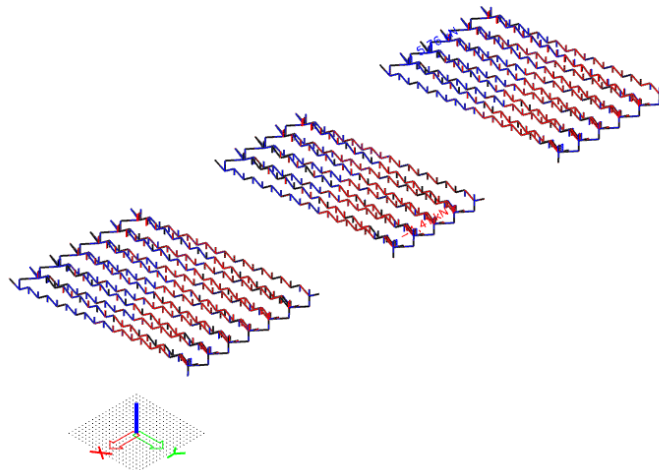

Slika 7.1.3.6. Poprečna sila V_y

1D internal forces

Values: V_z
Linear calculation
Combination: ULS-Set B (auto)
Coordinate system: Principal
Extreme 1D: Global
Selection: All
Filter: Cross-section = ispunje glavna - CFRHS140X80X6

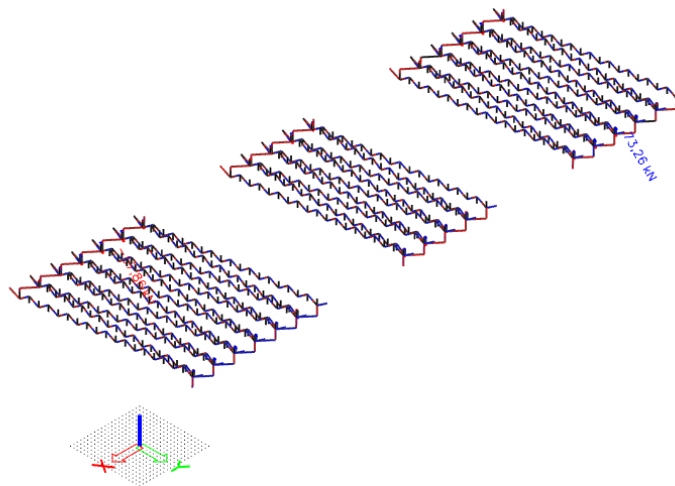

Slika 7.1.3.7. Poprečna sila V_z

1D internal forces

Values: N
Linear calculation
Combination: ULS-Set B (auto)
Coordinate system: Principal
Extreme 1D: Global
Selection: All
Filter: Cross-section = ispunje glavna - CFRHS140X80X6

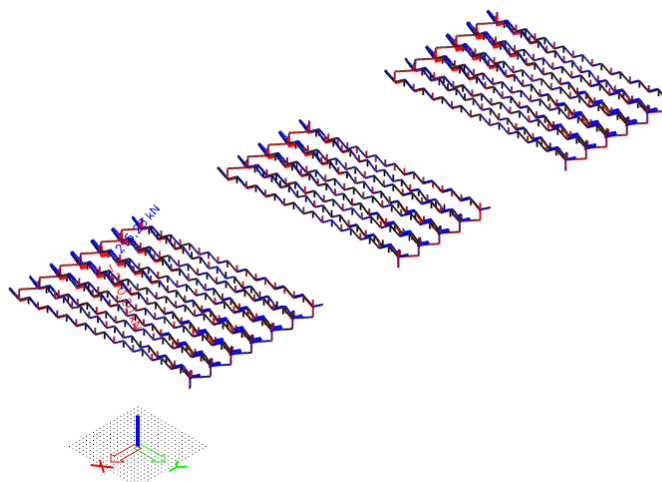

Slika 7.1.3.8. Uzdužna sila N

EC-EN 1993 Steel check ULS

Linear calculation
 Combination: ULS-Set B (auto)
 Coordinate system: Principal
 Extreme 1D: Cross-section
 Selection: All
 Filter: Cross-section = ispunje glavna - CFRHS140X80X6

EN 1993-1-1 Code Check

National annex: Standard EN

Member B2007 0,000 / 3,905 m CFRHS140X80X6 S 355 ULS-Set B (auto) 0,48 -

Combination key

ULS-Set B (auto) / 1.35*LC1 + 1.50*snijeg + 1.35*dodatno stalno + 0.90*3DWind14 + 1.50*temperatura -

Partial safety factors

γ_{M0} for resistance of cross-sections	1,00
γ_{M1} for resistance to instability	1,00
γ_{M2} for resistance of net sections	1,25

Material

Yield strength	f_y	355,0	MPa
Ultimate strength	f_u	490,0	MPa
Fabrication		Rolled	

....SECTION CHECK:....

The critical check is on position 0,000 m

Internal forces		Calculated	Unit
Normal force	N_{Ed}	-27,34	kN
Shear force	$V_{y,Ed}$	0,49	kN
Shear force	$V_{z,Ed}$	0,78	kN
Torsion	T_{Ed}	-0,60	kNm
Bending moment	$M_{y,Ed}$	-1,89	kNm
Bending moment	$M_{z,Ed}$	0,00	kNm

Classification for cross-section design

Classification according to EN 1993-1-1 article 5.5.2

Classification of Internal and Outstand parts according to EN 1993-1-1 Table 5.2 Sheet 1 & 2

Id	Type	c [mm]	t [mm]	σ_1 [kN/m ²]	σ_2 [kN/m ²]	ψ [-]	κ_σ [-]	α [-]	c/t [-]	Class 1 Limit [-]	Class 2 Limit [-]	Class 3 Limit [-]	Class
1	I	62	6	3,256e+04	3,256e+04	1,00		1,00	10,33	22,78	27,66	30,92	1
3	I	122	6	3,066e+04	-7,905e+03	-0,26		0,80	20,33	30,40	36,49	54,86	1
5	I	62	6	-9,801e+03	-9,801e+03								
7	I	122	6	-7,905e+03	3,066e+04	-0,26		0,80	20,33	30,40	36,49	54,86	1

Note: The Classification limits have been set according to Semi-Comp+.
 The cross-section is classified as Class 1

Compression check

According to EN 1993-1-1 article 6.2.4 and formula (6.9)

Cross-section area	A	2,4030e-03	m ²
Compression resistance	$N_{c,Rd}$	853,07	kN
Unity check		0,03	-

Bending moment check for M_y

According to EN 1993-1-1 article 6.2.5 and formula (6.12),(6.13)

Plastic section modulus	$W_{pl,y}$	1,0709e-04	m ³
Plastic bending moment	$M_{pl,y,Rd}$	38,02	kNm
Unity check		0,05	-

Shear check for V_y

According to EN 1993-1-1 article 6.2.6 and formula (6.17)

Shear correction factor	η	1,20	
Shear area	A_v	8,7382e-04	m ²
Plastic shear resistance for V_y	$V_{pl,y,Rd}$	179,10	kN
Unity check		0,00	-

Shear check for V_z

According to EN 1993-1-1 article 6.2.6 and formula (6.17)

Shear correction factor	η	1,20	
Shear area	A_v	1,5292e-03	m ²
Plastic shear resistance for V_z	$V_{pl,z,Rd}$	313,42	kN
Unity check		0,00	-

Torsion check

According to EN 1993-1-1 article 6.2.7 and formula (6.23)

Index of fibre	Fibre	1	
Total torsional moment	T_{Ed}	5,0	MPa
Elastic shear resistance	T_{Rd}	205,0	MPa
Unity check		0,02	-

Note: The unity check for torsion is lower than the limit value of 0,05. Therefore torsion is considered as insignificant and is ignored in the combined checks.

Combined bending, axial force and shear force check

According to EN 1993-1-1 article 6.2.9.1 and formula (6.31)

Design plastic moment resistance reduced due to N_{Ed}	$M_{N,y,Rd}$	38,02	kNm
Unity check		0,05	-

Note: Since the shear forces are less than half the plastic shear resistances their effect on the moment resistances is neglected.

The member satisfies the section check.

....:STABILITY CHECK:....

Classification for member buckling design

Decisive position for stability classification: 0,000 m

Classification according to EN 1993-1-1 article 5.5.2

Classification of Internal and Outstand parts according to EN 1993-1-1 Table 5.2 Sheet 1 & 2

Id	Type	c [mm]	t [mm]	σ_1 [kN/m ²]	σ_2 [kN/m ²]	Ψ [-]	k_{σ} [-]	α [-]	c/t [-]	Class 1 Limit [-]	Class 2 Limit [-]	Class 3 Limit [-]	Class
1	I	62	6	3,256e+04	3,256e+04	1,00		1,00	10,33	22,78	27,66	30,92	1
3	I	122	6	3,066e+04	-7,905e+03	-0,26		0,80	20,33	30,40	36,49	54,86	1
5	I	62	6	-9,801e+03	-9,801e+03								
7	I	122	6	-7,905e+03	3,066e+04	-0,26		0,80	20,33	30,40	36,49	54,86	1

Note: The Classification limits have been set according to Semi-Comp+. The cross-section is classified as Class 1

Flexural Buckling check

According to EN 1993-1-1 article 6.3.1.1 and formula (6.46)

Buckling parameters		yy	zz
Sway type		sway	non-sway
System length	L	3,905	3,905 m
Buckling factor	k	3,51	1,00
Buckling length	l_{cr}	13,705	3,905 m
Critical Euler load	N_{cr}	65,88	337,02 kN
Slenderness	λ	274,96	121,57
Relative slenderness	λ_{rel}	3,60	1,59
Limit slenderness	$\lambda_{rel,0}$	0,20	0,20
Buckling curve	a	a	
Imperfection	α	0,21	0,21
Reduction factor	χ	0,07	0,34
Buckling resistance	$N_{b,Rd}$	62,18	287,08 kN

Flexural Buckling verification

Cross-section area	A	2,4030e-03	m ²
Buckling resistance	$N_{b,Rd}$	62,18	kN
Unity check		0,44	-

Torsional(-Flexural) Buckling check

According to EN 1993-1-1 article 6.3.1.1 and formula (6.46)

Note: The cross-section concerns a RHS section which is not susceptible to Torsional(-Flexural) Buckling.

Lateral Torsional Buckling check

According to EN 1993-1-1 article 6.3.2.1

Note: The cross-section concerns an RHS section with ' $h / b < 10 / \lambda_{rel,z}$ '.

This section is thus not susceptible to Lateral Torsional Buckling.

Bending and axial compression check

According to EN 1993-1-1 article 6.3.3 and formula (6.61),(6.62)

Bending and axial compression check parameters			
Interaction method		alternative method 1	
Cross-section area	A	2,4030e-03	m ²
Plastic section modulus	$W_{pl,y}$	1,0709e-04	m ³
Plastic section modulus	$W_{pl,z}$	7,2430e-05	m ³
Design compression force	N_{Ed}	27,34	kN
Design bending moment (maximum)	$M_{y,Ed}$	-1,89	kNm
Design bending moment (maximum)	$M_{z,Ed}$	0,48	kNm
Characteristic compression resistance	N_{Rk}	853,07	kN
Characteristic moment resistance	$M_{y,Rk}$	38,02	kNm

Bending and axial compression check parameters			
Characteristic moment resistance	$M_{z,Rk}$	25,71	kNm
Reduction factor	χ_y	0,07	
Reduction factor	χ_z	0,34	
Reduction factor	χ_{LT}	1,00	
Interaction factor	k_{yy}	0,56	
Interaction factor	k_{yz}	0,68	
Interaction factor	k_{zy}	0,59	
Interaction factor	k_{zz}	1,16	

Maximum moment $M_{y,Ed}$ is derived from beam B2007 position 0,000 m.
Maximum moment $M_{z,Ed}$ is derived from beam B2007 position 1,953 m.

Interaction method 1 parameters			
Critical Euler load	$N_{cr,y}$	65,88	kN
Critical Euler load	$N_{cr,z}$	337,02	kN
Elastic critical load	$N_{cr,T}$	134366,32	kN
Plastic section modulus	$W_{pl,y}$	1,0709e-04	m ³
Elastic section modulus	$W_{el,y}$	8,5290e-05	m ³
Plastic section modulus	$W_{pl,z}$	7,2430e-05	m ³
Elastic section modulus	$W_{el,z}$	6,1990e-05	m ³
Second moment of area	I_y	5,9700e-06	m ⁴
Second moment of area	I_z	2,4796e-06	m ⁴
Torsional constant	I_t	5,8380e-06	m ⁴
Method for equivalent moment factor $C_{my,0}$		Table A.2 Line 1 (Linear)	
Ratio of end moments	ψ_y	-0,61	
Equivalent moment factor	$C_{my,0}$	0,52	
Method for equivalent moment factor $C_{mz,0}$		Table A.2 Line 4 (Line load)	
Equivalent moment factor	$C_{mz,0}$	1,00	
Factor	μ_y	0,60	
Factor	μ_z	0,94	
Factor	ϵ_y	1,94	
Factor	a_{LT}	0,02	
Critical moment for uniform bending	$M_{cr,0}$	399,03	kNm
Relative slenderness	$\lambda_{rel,0}$	0,31	
Limit relative slenderness	$\lambda_{rel,0,lim}$	0,31	
Equivalent moment factor	C_{my}	0,52	
Equivalent moment factor	C_{mz}	1,00	
Equivalent moment factor	C_{mLT}	1,00	
Factor	b_{LT}	0,00	
Factor	c_{LT}	0,00	
Factor	d_{LT}	0,00	
Factor	e_{LT}	0,00	
Factor	w_y	1,26	
Factor	w_z	1,17	
Factor	η_{pl}	0,03	
Maximum relative slenderness	$\lambda_{rel,max}$	3,60	
Factor	C_{yy}	0,97	
Factor	C_{yz}	0,56	
Factor	C_{zy}	0,89	
Factor	C_{zz}	0,89	

Unity check (6.61) = 0,44 + 0,03 + 0,01 = 0,48 -
Unity check (6.62) = 0,10 + 0,03 + 0,02 = 0,15 -

The member satisfies the stability check.

Student version

7.2. Bočna rešetka

7.2.1. Gornji pojas bočne rešetke – Pozicija 4

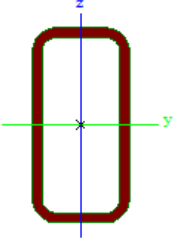
Name	gp bocna	
Type	CFRHS200X100X10	
Source description	Rautaruukki Oyj / Structural Hollow Sections EN10219 / Ed.2007	
Item material	S 355	
Fabrication	rolled	
Flexural buckling y-y	a	
Flexural buckling z-z	a	
Lateral torsional buckling	Default	
Use 2D FEM analysis	x	
		
A [m ²]	5,2570e-03	
A _{y, z} [m ²]	1,7501e-03	3,5002e-03
I _{y, z} [m ⁴]	2,4444e-05	8,1774e-06
I _w [m ⁶], t [m ⁴]	5,0000e-08	2,1541e-05
W _{el, y, z} [m ³]	2,4444e-04	1,6355e-04
W _{pl, y, z} [m ³]	3,1808e-04	1,9525e-04
d _{y, z} [mm]	0	0
c _{YUCS, ZUCS} [mm]	50	100
α [deg]	0,00	
A _{L, D} [m ² /m]	5,5700e-01	1,0510e+00
M _{pl, y, z} +, - [Nm]	1,13e+05	1,13e+05
M _{pl, z, y} +, - [Nm]	6,92e+04	6,92e+04

Slika 7.2.1.1. Karakteristike poprečnog presjeka gornjeg pojasa bočne rešetke

EC-EN 1993 Steel check ULS

Values: **UC** Overall
 Linear calculation
 Combination: ULS-Set B (auto)
 Coordinate system: Principal
 Extreme 1D: Cross-section
 Selection: All
 Filter: Cross-section = gp bocna -
 CFRHS200X100X10

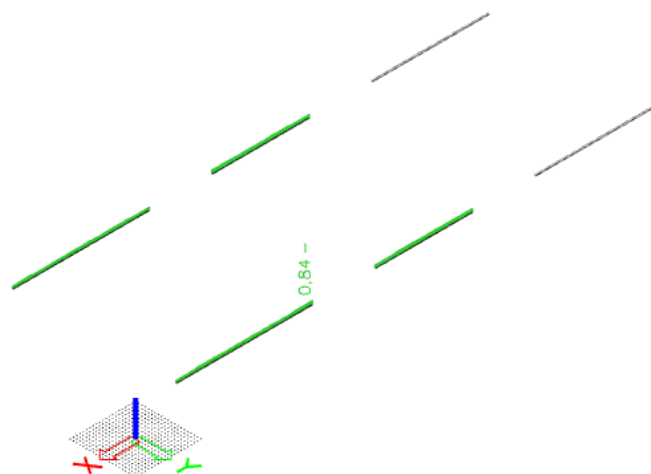

Slika 7.2.1.2. Prikaz iskoristivosti gornjeg pojasa bočne rešetke

1D internal forces
 Values: M_x
 Linear calculation
 Combination: ULS-Set B (auto)
 Coordinate system: Principal
 Extreme 1D: Global
 Selection: All
 Filter: Cross-section = gp bocna -
 CFRHS200X100X10

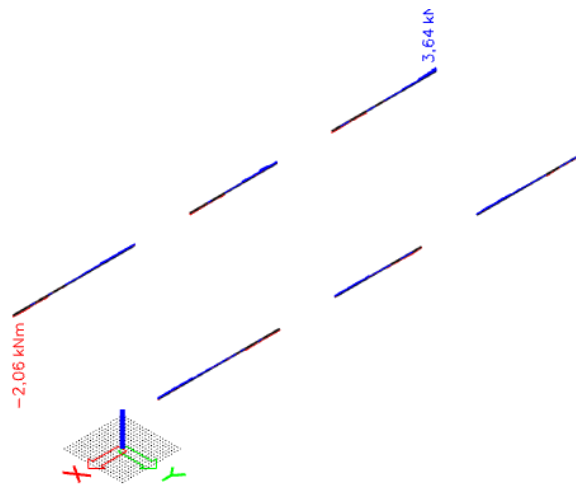

Slika 7.2.1.3.Moment M_x

1D internal forces
 Values: M_y
 Linear calculation
 Combination: ULS-Set B (auto)
 Coordinate system: Principal
 Extreme 1D: Global
 Selection: All
 Filter: Cross-section = gp bocna -
 CFRHS200X100X10

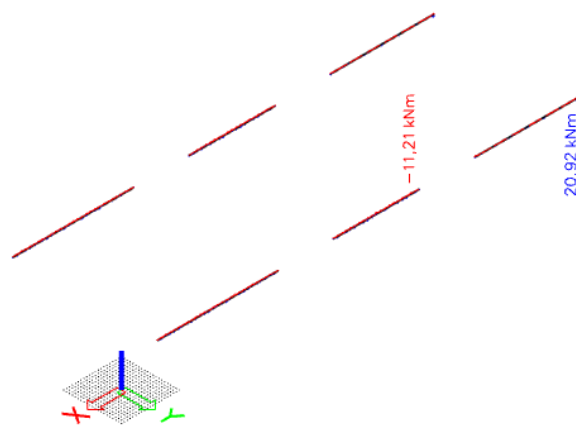

Slika 7.2.1.4.Moment M_y

1D internal forces
 Values: M_z
 Linear calculation
 Combination: ULS-Set B (auto)
 Coordinate system: Principal
 Extreme 1D: Global
 Selection: All
 Filter: Cross-section = gp bocna -
 CFRHS200X100X10

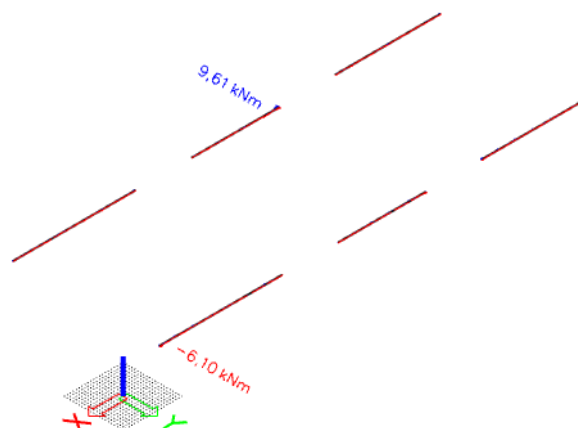

Slika 7.2.1.5.Moment M_z

1D internal forces

Values: V_y
Linear calculation
Combination: ULS-Set B (auto)
Coordinate system: Principal
Extreme 1D: Global
Selection: All
Filter: Cross-section = gp bocna -
CFRHS200X100X10

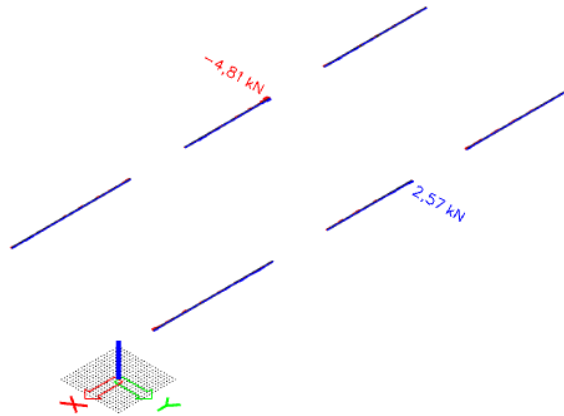

Slika 7.2.1.6. Poprečna sila V_y

1D internal forces

Values: V_z
Linear calculation
Combination: ULS-Set B (auto)
Coordinate system: Principal
Extreme 1D: Global
Selection: All
Filter: Cross-section = gp bocna -
CFRHS200X100X10

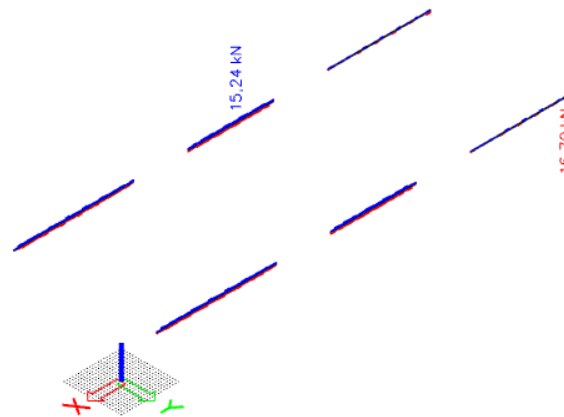

Slika 7.2.1.7. Poprečna sila V_z

1D internal forces

Values: N
Linear calculation
Combination: ULS-Set B (auto)
Coordinate system: Principal
Extreme 1D: Global
Selection: All
Filter: Cross-section = gp bocna -
CFRHS200X100X10

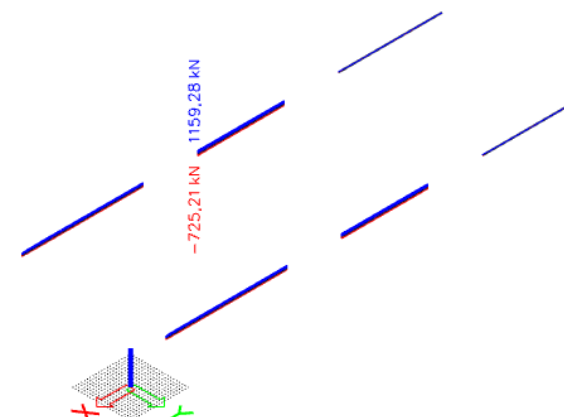

Slika 7.2.1.8. Uzdužna sila N

EC-EN 1993 Steel check ULS

Linear calculation
 Combination: ULS-Set B (auto)
 Coordinate system: Principal
 Extreme 1D: Cross-section
 Selection: All
 Filter: Cross-section = gp bocna - CFRHS200X100X10

EN 1993-1-1 Code Check

National annex: Standard EN

Member B109 | **0,000 / 1,500 m** | **CFRHS200X100X10** | **S 355** | **ULS-Set B (auto)** | **0,84 -**

Combination key
 ULS-Set B (auto) / 1.35*LC1 + 1.50*korisno + 1.50*snijeg
 + 1.35*dodatno stalno + 0.90*3DWind15 +
 1.50*temperatura +

Partial safety factors

γ_{M0} for resistance of cross-sections	1,00
γ_{M1} for resistance to instability	1,00
γ_{M2} for resistance of net sections	1,25

Material

Yield strength	f_y	355,0	MPa
Ultimate strength	f_u	490,0	MPa
Fabrication		Rolled	

....:SECTION CHECK:....

The critical check is on position 0,000 m

Internal forces		Calculated	Unit
Normal force	N_{Ed}	-633,11	kN
Shear force	$V_{y,Ed}$	-0,49	kN
Shear force	$V_{z,Ed}$	-7,96	kN
Torsion	T_{Ed}	-1,10	kNm
Bending moment	$M_{y,Ed}$	5,43	kNm
Bending moment	$M_{z,Ed}$	0,66	kNm

Classification for cross-section design

Classification according to EN 1993-1-1 article 5.5.2

Classification of Internal and Outstand parts according to EN 1993-1-1 Table 5.2 Sheet 1 & 2

Id	Type	c [mm]	t [mm]	σ_1 [kN/m ²]	σ_2 [kN/m ²]	ψ [-]	k_{σ} [-]	α [-]	c/t [-]	Class 1 Limit [-]	Class 2 Limit [-]	Class 3 Limit [-]	Class
1	I	70	10	9,654e+04	1,022e+05	0,94		1,00	7,00	22,78	27,66	31,52	1
3	I	170	10	1,052e+05	1,430e+05	0,74		1,00	17,00	22,78	27,66	34,04	1
5	I	70	10	1,444e+05	1,388e+05	0,96		1,00	7,00	22,78	27,66	31,34	1
7	I	170	10	1,358e+05	9,796e+04	0,72		1,00	17,00	22,78	27,66	34,22	1

Note: The Classification limits have been set according to Semi-Comp+.
 The cross-section is classified as Class 1

Compression check

According to EN 1993-1-1 article 6.2.4 and formula (6.9)

Cross-section area	A	5,2570e-03	m ²
Compression resistance	$N_{c,Rd}$	1866,24	kN
Unity check		0,34	-

Bending moment check for M_y

According to EN 1993-1-1 article 6.2.5 and formula (6.12),(6.13)

Plastic section modulus	$W_{pl,y}$	3,1808e-04	m ³
Plastic bending moment	$M_{pl,y,Rd}$	112,92	kNm
Unity check		0,05	-

Bending moment check for M_z

According to EN 1993-1-1 article 6.2.5 and formula (6.12),(6.13)

Plastic section modulus	$W_{pl,z}$	1,9525e-04	m ³
Plastic bending moment	$M_{pl,z,Rd}$	69,31	kNm
Unity check		0,01	-

Shear check for V_y

According to EN 1993-1-1 article 6.2.6 and formula (6.17)

Shear correction factor	η	1,20	
Shear area	A_v	1,7523e-03	m ²
Plastic shear resistance for V_y	$V_{pl,y,Rd}$	359,16	kN
Unity check		0,00	-

Shear check for V_z

According to EN 1993-1-1 article 6.2.6 and formula (6.17)

Shear correction factor	η	1,20	
Shear area	A_w	3,5047e-03	m ²
Plastic shear resistance for V_z	$V_{pl,z,Rd}$	718,31	kN
Unity check		0,01	-

Torsion check

According to EN 1993-1-1 article 6.2.7 and formula (6.23)

Index of fibre	Fibre	1	
Total torsional moment	T_{Ed}	3,2	MPa
Elastic shear resistance	T_{Rd}	205,0	MPa
Unity check		0,02	-

Note: The unity check for torsion is lower than the limit value of 0,05. Therefore torsion is considered as insignificant and is ignored in the combined checks.

Combined bending, axial force and shear force check

According to EN 1993-1-1 article 6.2.9.1 and formula (6.41)

Design plastic moment resistance reduced due to N_{Ed}	$M_{N,y,Rd}$	99,48	kNm
Exponent of bending ratio y	α	1,91	
Design plastic moment resistance reduced due to N_{Ed}	$M_{N,z,Rd}$	52,02	kNm
Exponent of bending ratio z	β	1,91	

Unity check (6.41) = 0,00 + 0,00 = 0,00 -

Note: Since the shear forces are less than half the plastic shear resistances their effect on the moment resistances is neglected.

The member satisfies the section check.

....:STABILITY CHECK:....

Classification for member buckling design

Decisive position for stability classification: 0,000 m

Classification according to EN 1993-1-1 article 5.5.2

Classification of Internal and Outstand parts according to EN 1993-1-1 Table 5.2 Sheet 1 & 2

Id	Type	c [mm]	t [mm]	σ_1 [kN/m ²]	σ_2 [kN/m ²]	Ψ [-]	k_{σ} [-]	α [-]	c/t [-]	Class 1 Limit [-]	Class 2 Limit [-]	Class 3 Limit [-]	Class
1	I	70	10	9,654e+04	1,022e+05	0,94		1,00	7,00	22,78	27,66	31,52	1
3	I	170	10	1,052e+05	1,430e+05	0,74		1,00	17,00	22,78	27,66	34,04	1
5	I	70	10	1,444e+05	1,388e+05	0,96		1,00	7,00	22,78	27,66	31,34	1
7	I	170	10	1,358e+05	9,796e+04	0,72		1,00	17,00	22,78	27,66	34,22	1

Note: The Classification limits have been set according to Semi-Comp+.

The cross-section is classified as Class 1

Flexural Buckling check

According to EN 1993-1-1 article 6.3.1.1 and formula (6.46)

Buckling parameters		yy	zz	
Sway type		sway	non-sway	
System length	L	1,500	6,000	m
Buckling factor	k	1,40	0,69	
Buckling length	l_{cr}	2,104	4,119	m
Critical Euler load	N_{cr}	11443,31	999,00	kN
Slenderness	λ	30,86	104,44	
Relative slenderness	λ_{rel}	0,40	1,37	
Limit slenderness	$\lambda_{rel,0}$	0,20	0,20	
Buckling curve		a	a	
Imperfection	α	0,21	0,21	
Reduction factor	χ	0,95	0,43	
Buckling resistance	$N_{b,Rd}$	1776,23	810,91	kN

Flexural Buckling verification

Cross-section area	A	5,2570e-03	m ²
Buckling resistance	$N_{b,Rd}$	810,91	kN
Unity check		0,78	-

Torsional(-Flexural) Buckling check

According to EN 1993-1-1 article 6.3.1.1 and formula (6.46)

Note: The cross-section concerns a RHS section which is not susceptible to Torsional(-Flexural) Buckling.

Lateral Torsional Buckling check

According to EN 1993-1-1 article 6.3.2.1

Note: The cross-section concerns an RHS section with ' $h/b < 10/\lambda_{rel,z}$ '.

This section is thus not susceptible to Lateral Torsional Buckling.

Bending and axial compression check

According to EN 1993-1-1 article 6.3.3 and formula (6.61),(6.52)

Bending and axial compression check parameters			
Interaction method		alternative method 1	
Cross-section area	A	5,2570e-03	m ²
Plastic section modulus	W _{pl,y}	3,1808e-04	m ³
Plastic section modulus	W _{pl,z}	1,9525e-04	m ³
Design compression force	N _{Ed}	633,11	kN
Design bending moment (maximum)	M _{y,Ed}	-5,61	kNm
Design bending moment (maximum)	M _{z,Ed}	2,74	kNm
Characteristic compression resistance	N _{Rk}	1866,24	kN
Characteristic moment resistance	M _{y,Rk}	112,92	kNm
Characteristic moment resistance	M _{z,Rk}	69,31	kNm
Reduction factor	χ _y	0,95	
Reduction factor	χ _z	0,43	
Reduction factor	χ _{LT}	1,00	
Interaction factor	k _{yy}	1,22	
Interaction factor	k _{yz}	0,94	
Interaction factor	k _{zy}	0,59	
Interaction factor	k _{zz}	0,73	

Maximum moment M_{y,Ed} is derived from beam B109 position 1,500 m.
Maximum moment M_{z,Ed} is derived from beam B5182 position 1,500 m.

Interaction method 1 parameters			
Critical Euler load	N _{cr,y}	11443,31	kN
Critical Euler load	N _{cr,z}	999,00	kN
Elastic critical load	N _{cr,T}	280847,90	kN
Plastic section modulus	W _{pl,y}	3,1808e-04	m ³
Elastic section modulus	W _{el,y}	2,4444e-04	m ³
Plastic section modulus	W _{pl,z}	1,9525e-04	m ³
Elastic section modulus	W _{el,z}	1,6355e-04	m ³
Second moment of area	I _y	2,4444e-05	m ⁴
Second moment of area	I _z	8,1774e-06	m ⁴
Torsional constant	I _t	2,1541e-05	m ⁴
Method for equivalent moment factor C _{my,0}		Table A.2 Line 2 (General)	
Design bending moment (maximum)	M _{y,Ed}	-5,61	kNm
Maximum relative deflection	δ _z	0,0	mm
Equivalent moment factor	C _{my,0}	0,96	
Method for equivalent moment factor C _{mz,0}		Table A.2 Line 2 (General)	
Design bending moment (maximum)	M _{z,Ed}	2,74	kNm
Maximum relative deflection	δ _y	1,7	mm
Equivalent moment factor	C _{mz,0}	0,55	
Factor	μ _y	1,00	
Factor	μ _z	0,51	
Factor	ε _y	0,19	
Factor	a _{LT}	0,12	
Critical moment for uniform bending	M _{cr,0}	905,80	kNm
Relative slenderness	λ _{rel,0}	0,35	
Limit relative slenderness	λ _{rel,0,lim}	0,18	
Equivalent moment factor	C _{my}	0,96	
Equivalent moment factor	C _{mz}	0,55	
Equivalent moment factor	C _{mLT}	1,00	
Factor	b _{LT}	0,00	
Factor	c _{LT}	0,00	
Factor	d _{LT}	0,00	
Factor	e _{LT}	0,00	
Factor	w _y	1,30	
Factor	w _z	1,19	
Factor	η _{pl}	0,34	
Maximum relative slenderness	λ _{rel,max}	1,37	
Factor	C _{yy}	0,83	
Factor	C _{yz}	0,92	
Factor	C _{zy}	0,55	
Factor	C _{zz}	1,05	

Unity check (6.61) = 0,36 + 0,06 + 0,04 = 0,45 -

Unity check (6.62) = 0,78 + 0,03 + 0,03 = 0,84 -

The member satisfies the stability check.

7.2.2. Donji pojas bočne rešetke – Pozicija 5

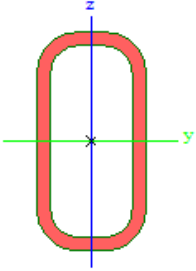
Name	dp bocna	
Type	CFRHS200X100X12.5	
Source description	Rautaruukki Oyj / Structural Hollow Sections EN10219 / Ed.2007	
Item material	S 355	
Fabrication	rolled	
Flexural buckling y-y	a	
Flexural buckling z-z	a	
Lateral torsional buckling	Default	
Use 2D FEM analysis	x	
		
A [m ²]	6,2040e-03	
A _{y, z} [m ²]	2,0640e-03	4,1280e-03
I _{y, z} [m ⁴]	2,6589e-05	8,9215e-06
I _w [m ⁶], t [m ⁴]	6,2500e-08	2,4738e-05
W _{el} y, z [m ³]	2,6589e-04	1,7843e-04
W _{pl} y, z [m ³]	3,5913e-04	2,2078e-04
d y, z [mm]	0	0
c YUCS, ZUCS [mm]	50	100
α [deg]	0,00	
A _{L, D} [m ² /m]	5,3600e-01	9,9220e-01
M _{py} +, - [Nm]	1,27e+05	1,27e+05
M _{pz} +, - [Nm]	7,82e+04	7,82e+04

Slika 7.2.2.1. Karakteristike poprečnog presjeka donjeg pojasa bočne rešetke

EC-EN 1993 Steel check ULS

Values: UC Overall
 Linear calculation
 Combination: ULS-Set B (auto)
 Coordinate system: Principal
 Extreme 1D: Cross-section
 Selection: All
 Filter: Cross-section = dp bocna -
 CFRHS200X100X12.5

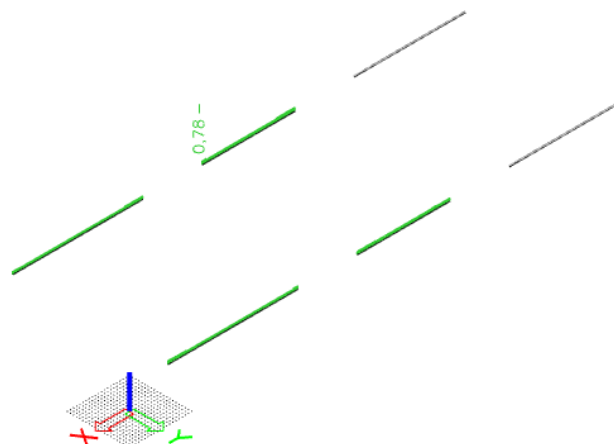

Slika 7.2.2.1. Prikaz iskoristivosti donjeg pojasa bočne rešetke

1D internal forces

Values: M_x
Linear calculation
Combination: ULS-Set B (auto)
Coordinate system: Principal
Extreme 1D: Global
Selection: All
Filter: Cross-section = dp bocna - CFRHS200X100X12.5

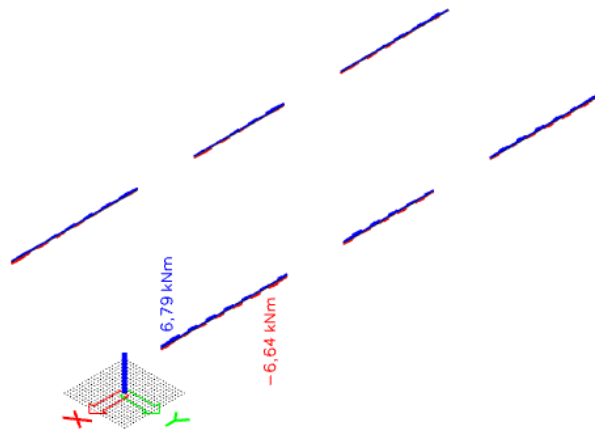

Slika 7.2.2.3. Moment M_x

1D internal forces

Values: M_y
Linear calculation
Combination: ULS-Set B (auto)
Coordinate system: Principal
Extreme 1D: Global
Selection: All
Filter: Cross-section = dp bocna - CFRHS200X100X12.5

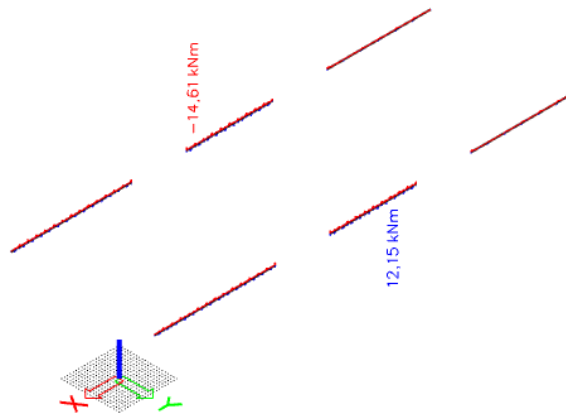

Slika 7.2.2.4. Moment M_y

1D internal forces

Values: M_z
Linear calculation
Combination: ULS-Set B (auto)
Coordinate system: Principal
Extreme 1D: Global
Selection: All
Filter: Cross-section = dp bocna - CFRHS200X100X12.5

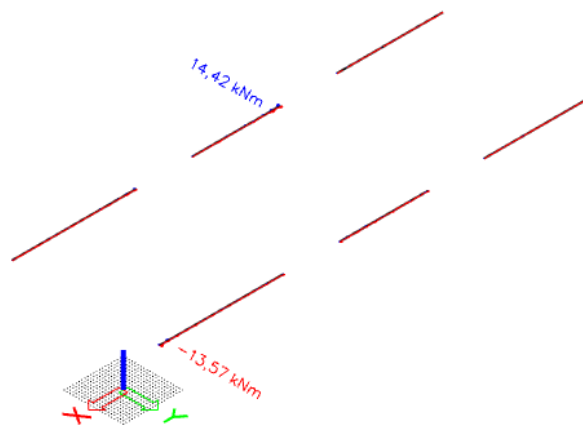

Slika 7.2.2.5. Moment M_z

1D internal forces

Values: V_y
Linear calculation
Combination: ULS-Set B (auto)
Coordinate system: Principal
Extreme 1D: Global
Selection: All
Filter: Cross-section = dp bocna -
CFRHS200X100X12.5

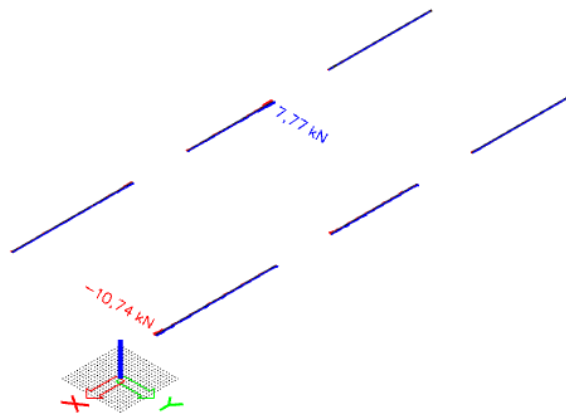

Slika 7.2.2.6. Poprečna sila V_y

1D internal forces

Values: V_z
Linear calculation
Combination: ULS-Set B (auto)
Coordinate system: Principal
Extreme 1D: Global
Selection: All
Filter: Cross-section = dp bocna -
CFRHS200X100X12.5

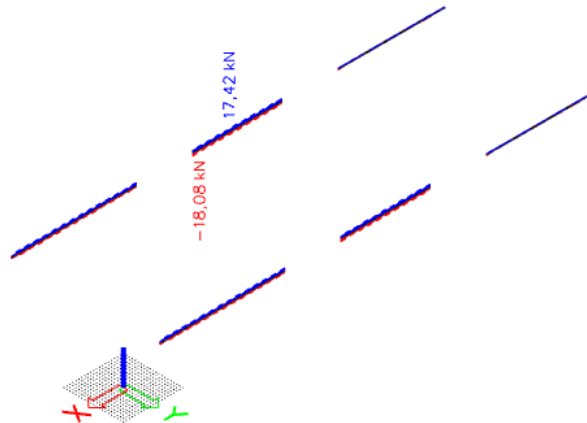

Slika 7.2.2.7. Poprečna sila V_z

1D internal forces

Values: N
Linear calculation
Combination: ULS-Set B (auto)
Coordinate system: Principal
Extreme 1D: Global
Selection: All
Filter: Cross-section = dp bocna -
CFRHS200X100X12.5

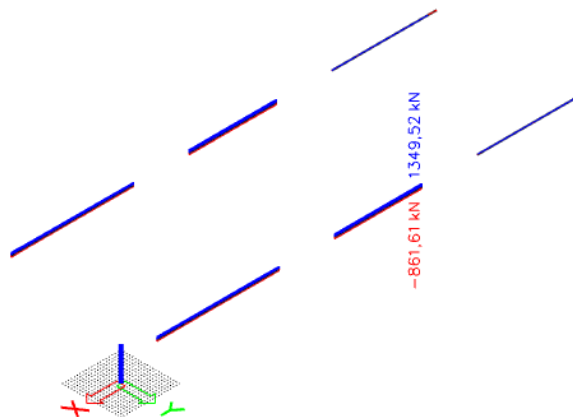

Slika 7.2.2.8. Uzdužna sila N

EC-EN 1993 Steel check ULS

Linear calculation
 Combination: ULS-Set B (auto)
 Coordinate system: Principal
 Extreme 1D: Cross-section
 Selection: All
 Filter: Cross-section = dp bocna - CFRHS200X100X12.5

EN 1993-1-1 Code Check

National annex: Standard EN

Member B5353	0,000 / 1,500 m	CFRHS200X100X12.5	S 355	ULS-Set B (auto)	0,78 -
--------------	-----------------	-------------------	-------	------------------	--------

Combination key

ULS-Set B (auto) / 1.35*LC1 + 1.50*korisno + 1.50*snijeg
 + 1.35*dodatno stalno + 0.90*3DWind13 +
 1.50*temperatura +

Partial safety factors

γ_{M0} for resistance of cross-sections	1,00
γ_{M1} for resistance to instability	1,00
γ_{M2} for resistance of net sections	1,25

Material

Yield strength	f_y	355,0	MPa
Ultimate strength	f_u	490,0	MPa
Fabrication		Rolled	

....:SECTION CHECK:....

The critical check is on position 0,000 m

Internal forces		Calculated	Unit
Normal force	N_{Ed}	-796,81	kN
Shear force	$V_{y,Ed}$	-2,81	kN
Shear force	$V_{z,Ed}$	11,14	kN
Torsion	T_{Ed}	-2,40	kNm
Bending moment	$M_{y,Ed}$	-7,19	kNm
Bending moment	$M_{z,Ed}$	0,16	kNm

Classification for cross-section design

Classification according to EN 1993-1-1 article 5.5.2

Classification of Internal and Outstand parts according to EN 1993-1-1 Table 5.2 Sheet 1 & 2

Id	Type	c [mm]	t [mm]	σ_1 [kN/m ²]	σ_2 [kN/m ²]	ψ [-]	k_{σ} [-]	α [-]	c/t [-]	Class 1 Limit [-]	Class 2 Limit [-]	Class 3 Limit [-]	Class
1	I	63	13	1,533e+05	1,544e+05	0,99		1,00	5,00	22,78	27,66	31,00	1
3	I	162	13	1,513e+05	1,073e+05	0,71		1,00	13,00	22,78	27,66	34,39	1
5	I	63	13	1,037e+05	1,026e+05	0,99		1,00	5,00	22,78	27,66	31,03	1
7	I	162	13	1,057e+05	1,497e+05	0,71		1,00	13,00	22,78	27,66	34,43	1

Note: The Classification limits have been set according to Semi-Comp+.

The cross-section is classified as Class 1

Compression check

According to EN 1993-1-1 article 6.2.4 and formula (6.9)

Cross-section area	A	6,2040e-03	m ²
Compression resistance	$N_{c,Rd}$	2202,42	kN
Unity check		0,36	-

Bending moment check for M_y

According to EN 1993-1-1 article 6.2.5 and formula (6.12),(6.13)

Plastic section modulus	$W_{pl,y}$	3,5913e-04	m ³
Plastic bending moment	$M_{pl,y,Rd}$	127,49	kNm
Unity check		0,06	-

Bending moment check for M_z

According to EN 1993-1-1 article 6.2.5 and formula (6.12),(6.13)

Plastic section modulus	$W_{pl,z}$	2,2078e-04	m ³
Plastic bending moment	$M_{pl,z,Rd}$	78,38	kNm
Unity check		0,00	-

Shear check for V_y

According to EN 1993-1-1 article 6.2.6 and formula (6.17)

Shear correction factor	η	1,20	
Shear area	A_v	2,0680e-03	m ²
Plastic shear resistance for V_y	$V_{pl,y,Rd}$	423,86	kN
Unity check		0,01	-

Shear check for V_z

According to EN 1993-1-1 article 6.2.6 and formula (6.17)

Shear correction factor	η	1,20	
Shear area	A_v	4,1360e-03	m ²
Plastic shear resistance for V_z	$V_{pl,z,Rd}$	847,71	kN
Unity check		0,01	-

Torsion check

According to EN 1993-1-1 article 6.2.7 and formula (6.23)

Index of fibre	Fibre	1	
Total torsional moment	T_{Ed}	5,8	MPa
Elastic shear resistance	T_{Rd}	205,0	MPa
Unity check		0,03	-

Note: The unity check for torsion is lower than the limit value of 0,05. Therefore torsion is considered as insignificant and is ignored in the combined checks.

Combined bending, axial force and shear force check

According to EN 1993-1-1 article 6.2.9.1 and formula (6.41)

Design plastic moment resistance reduced due to N_{Ed}	$M_{N,y,Rd}$	108,49	kNm
Exponent of bending ratio y	α	1,95	
Design plastic moment resistance reduced due to N_{Ed}	$M_{N,z,Rd}$	55,40	kNm
Exponent of bending ratio z	β	1,95	

Unity check (6.41) = 0,01 + 0,00 = 0,01 -

Note: Since the shear forces are less than half the plastic shear resistances their effect on the moment resistances is neglected.

The member satisfies the section check.

....:STABILITY CHECK:....

Classification for member buckling design

Decisive position for stability classification: 1,500 m

Classification according to EN 1993-1-1 article 5.5.2

Classification of Internal and Outstand parts according to EN 1993-1-1 Table 5.2 Sheet 1 & 2

Id	Type	c [mm]	t [mm]	σ_1 [kN/m ²]	σ_2 [kN/m ²]	Ψ [-]	k_{σ} [-]	α [-]	c/t [-]	Class 1 Limit [-]	Class 2 Limit [-]	Class 3 Limit [-]	Class
1	I	63	13	1,132e+05	5,169e+04	0,72		1,00	5,00	22,78	27,66	34,22	1
3	I	162	13	7,953e+04	1,333e+05	0,60		1,00	13,00	22,78	27,66	35,95	1
5	I	63	13	1,438e+05	1,753e+05	0,82		1,00	5,00	22,78	27,66	32,97	1
7	I	162	13	1,775e+05	1,237e+05	0,70		1,00	13,00	22,78	27,66	34,55	1

Note: The Classification limits have been set according to Semi-Comp+.

The cross-section is classified as Class 1

Flexural Buckling check

According to EN 1993-1-1 article 6.3.1.1 and formula (6.46)

Buckling parameters		yy	zz	
Sway type		sway	non-sway	
System length	L	1,500	3,000	m
Buckling factor	k	4,07	0,52	
Buckling length	l_{cr}	6,101	1,557	m
Critical Euler load	N_{cr}	1480,67	7627,83	kN
Slenderness	λ	93,19	41,06	
Relative slenderness	λ_{rel}	1,22	0,54	
Limit slenderness	$\lambda_{rel,0}$	0,20	0,20	
Buckling curve	a	a	a	
Imperfection	α	0,21	0,21	
Reduction factor	χ	0,52	0,91	
Buckling resistance	$N_{b,Rd}$	1140,30	2009,19	kN

Flexural Buckling verification

Cross-section area	A	6,2040e-03	m ²
Buckling resistance	$N_{b,Rd}$	1140,30	kN
Unity check		0,70	-

Torsional(-Flexural) Buckling check

According to EN 1993-1-1 article 6.3.1.1 and formula (6.46)

Note: The cross-section concerns a RHS section which is not susceptible to Torsional(-Flexural) Buckling.

Lateral Torsional Buckling check

According to EN 1993-1-1 article 6.3.2.1

Note: The cross-section concerns an RHS section with 'h / b < 10 / $\lambda_{rel,z}$ '.

This section is thus not susceptible to Lateral Torsional Buckling.

Bending and axial compression check

According to EN 1993-1-1 article 6.3.3 and formula (6.61),(6.62)

Bending and axial compression check parameters			
Interaction method		alternative method 1	
Cross-section area	A	6,2040e-03	m ²
Plastic section modulus	W _{pl,y}	3,5913e-04	m ³
Plastic section modulus	W _{pl,z}	2,2078e-04	m ³
Design compression force	N _{Ed}	796,81	kN
Design bending moment (maximum)	M _{y,Ed}	8,79	kNm
Design bending moment (maximum)	M _{z,Ed}	-4,50	kNm
Characteristic compression resistance	N _{Rk}	2202,42	kN
Characteristic moment resistance	M _{y,Rk}	127,49	kNm
Characteristic moment resistance	M _{z,Rk}	78,38	kNm
Reduction factor	χ _y	0,52	
Reduction factor	χ _z	0,91	
Reduction factor	χ _{LT}	1,00	
Interaction factor	k _{yy}	0,74	
Interaction factor	k _{yz}	0,57	
Interaction factor	k _{zy}	0,76	
Interaction factor	k _{zz}	1,09	

Maximum moment M_{y,Ed} is derived from beam B5353 position 1,500 m.
Maximum moment M_{z,Ed} is derived from beam B5353 position 1,500 m.

Interaction method 1 parameters			
Critical Euler load	N _{cr,y}	1480,67	kN
Critical Euler load	N _{cr,z}	7627,83	kN
Elastic critical load	N _{cr,T}	351589,01	kN
Plastic section modulus	W _{pl,y}	3,5913e-04	m ³
Elastic section modulus	W _{el,y}	2,6589e-04	m ³
Plastic section modulus	W _{pl,z}	2,2078e-04	m ³
Elastic section modulus	W _{el,z}	1,7843e-04	m ³
Second moment of area	I _y	2,6589e-05	m ⁴
Second moment of area	I _z	8,9215e-06	m ⁴
Torsional constant	I _t	2,4738e-05	m ⁴
Method for equivalent moment factor C _{my,0}		Table A.2 Line 2 (General)	
Design bending moment (maximum)	M _{y,Ed}	8,79	kNm
Maximum relative deflection	δ _z	-0,1	mm
Equivalent moment factor	C _{my,0}	0,59	
Method for equivalent moment factor C _{mz,0}		Table A.2 Line 2 (General)	
Design bending moment (maximum)	M _{z,Ed}	-4,50	kNm
Maximum relative deflection	δ _y	-0,3	mm
Equivalent moment factor	C _{mz,0}	0,91	
Factor	μ _y	0,64	
Factor	μ _z	0,99	
Factor	ε _y	0,26	
Factor	a _{LT}	0,07	
Critical moment for uniform bending	M _{cr,0}	2033,37	kNm
Relative slenderness	λ _{rel,0}	0,25	
Limit relative slenderness	λ _{rel,0,lim}	0,28	
Equivalent moment factor	C _{my}	0,59	
Equivalent moment factor	C _{mz}	0,91	
Equivalent moment factor	C _{mLT}	1,00	
Factor	b _{LT}	0,00	
Factor	c _{LT}	0,00	
Factor	d _{LT}	0,00	
Factor	e _{LT}	0,02	
Factor	w _y	1,35	
Factor	w _z	1,24	
Factor	η _{pl}	0,36	
Maximum relative slenderness	λ _{rel,max}	1,22	
Factor	C _{yy}	1,11	
Factor	C _{yz}	0,66	
Factor	C _{zy}	1,05	
Factor	C _{zz}	0,92	

Unity check (6.61) = 0,70 + 0,05 + 0,03 = 0,78 -

Unity check (6.62) = 0,40 + 0,05 + 0,06 = 0,51 -

The member satisfies the stability check.

7.2.3. Ispune bočne rešetke – Pozicija 6

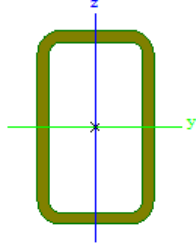
Name	ispune bocna	
Type	CFRHS100X60X6	
Source description	Rautaruukki Oyj / Structural Hollow Sections EN10219 / Ed.2007	
Item material	S 355	
Fabrication	rolled	
Flexural buckling y-y	a	
Flexural buckling z-z	a	
Lateral torsional buckling	Default	
Use 2D FEM analysis	x	
		
A [m ²]	1,6830e-03	
A _{y, z} [m ²]	6,3059e-04	1,0510e-03
I _{y, z} [m ⁴]	2,0530e-06	9,1200e-07
I _w [m ⁶], I _t [m ⁴]	1,4400e-09	2,1644e-06
W _{el} y, z [m ³]	4,1060e-05	3,0400e-05
W _{pl} y, z [m ³]	5,2540e-05	3,6640e-05
d y, z [mm]	0	0
c YUCS, ZUCS [mm]	30	50
α [deg]	0,00	
A _{L, D} [m ² /m]	2,9900e-01	5,6095e-01
M _{pl} +, - [Nm]	1,86e+04	1,86e+04
M _{plz} +, - [Nm]	1,30e+04	1,30e+04

Slika 7.2.3.1. Karakteristike poprečnog presjeka ispuna bočne rešetke

EC-EN 1993 Steel check ULS

Values: **UC** Overall

Linear calculation

Combination: ULS-Set B (auto)

Coordinate system: Principal

Extreme 1D: Cross-section

Selection: All

Filter: Cross-section = ispune bocna -

CFRHS100X60X6

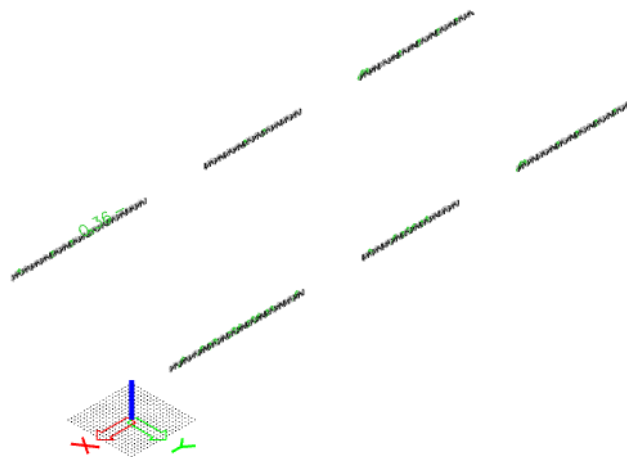

Slika 7.2.3.2. Prikaz iskoristivosti ispuna bočne rešetke

1D internal forces

Values: M_x

Linear calculation

Combination: ULS-Set B (auto)

Coordinate system: Principal

Extreme 1D: Global

Selection: All

Filter: Cross-section = ispune bocna -
CFRHS100X60X6

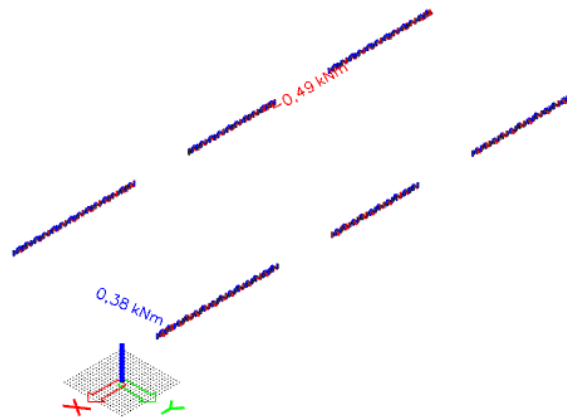

Slika 7.2.3.3. Moment M_x

1D internal forces

Values: M_y

Linear calculation

Combination: ULS-Set B (auto)

Coordinate system: Principal

Extreme 1D: Global

Selection: All

Filter: Cross-section = ispune bocna -
CFRHS100X60X6

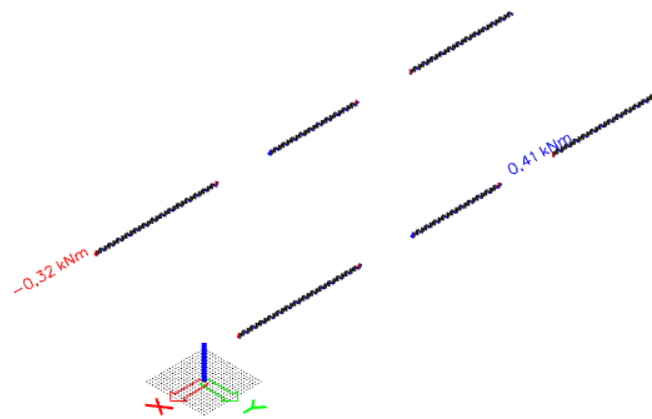

Slika 7.2.3.4. Moment M_y

1D internal forces

Values: M_z

Linear calculation

Combination: ULS-Set B (auto)

Coordinate system: Principal

Extreme 1D: Global

Selection: All

Filter: Cross-section = ispune bocna -
CFRHS100X60X6

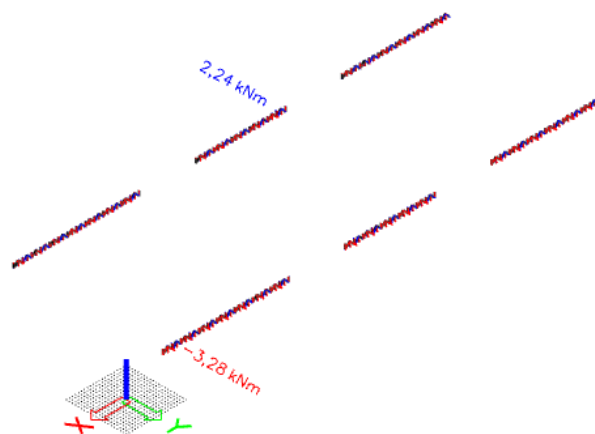

Slika 7.2.3.5. Moment M_z

1D internal forces

Values: V_y
Linear calculation
Combination: ULS-Set B (auto)
Coordinate system: Principal
Extreme 1D: Global
Selection: All
Filter: Cross-section = ispune bocna - CFRHS100X60X6

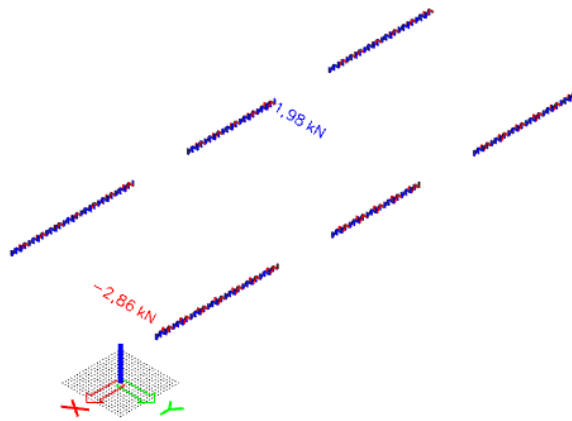

Slika 7.2.3.6. Poprečna sila V_y

1D internal forces

Values: V_z
Linear calculation
Combination: ULS-Set B (auto)
Coordinate system: Principal
Extreme 1D: Global
Selection: All
Filter: Cross-section = ispune bocna - CFRHS100X60X6

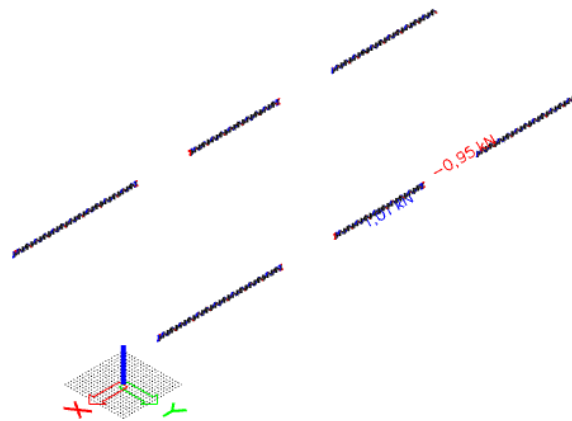

Slika 7.2.3.7. Poprečna sila V_z

1D internal forces

Values: N
Linear calculation
Combination: ULS-Set B (auto)
Coordinate system: Principal
Extreme 1D: Global
Selection: All
Filter: Cross-section = ispune bocna - CFRHS100X60X6

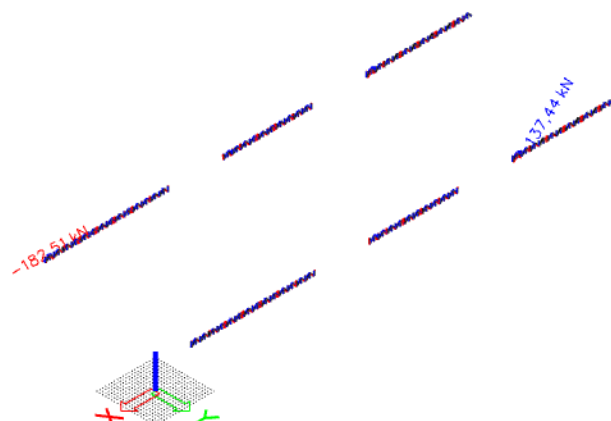

Slika 7.2.3.8. Uzdužna sila N

EC-EN 1993 Steel check ULS

Linear calculation
 Combination: ULS-Set B (auto)
 Coordinate system: Principal
 Extreme 1D: Cross-section
 Selection: All
 Filter: Cross-section = ispune bocna - CFRHS100X60X6

EN 1993-1-1 Code Check

National annex: Standard EN

Member B78 | **0,000 / 1,700 m** | **CFRHS100X60X6** | **S 355** | **ULS-Set B (auto)** | **0,36 -**

Combination key
 ULS-Set B (auto) / 1.35*LC1 + 1.50*korisno + 1.35*dodatno
 stalno + 1.50*3DWind2 + 0.90*temperatura -

Partial safety factors	
γ_{M0} for resistance of cross-sections	1,00
γ_{M1} for resistance to instability	1,00
γ_{M2} for resistance of net sections	1,25

Material			
Yield strength	f_y	355,0	MPa
Ultimate strength	f_u	490,0	MPa
Fabrication		Rolled	

....:SECTION CHECK:....

The critical check is on position **0,000 m**

Internal forces		Calculated	Unit
Normal force	N_{Ed}	-182,51	kN
Shear force	$V_{y,Ed}$	0,37	kN
Shear force	$V_{z,Ed}$	0,00	kN
Torsion	T_{Ed}	0,03	kNm
Bending moment	$M_{y,Ed}$	0,00	kNm
Bending moment	$M_{z,Ed}$	-0,21	kNm

Classification for cross-section design

Classification according to EN 1993-1-1 article 5.5.2

Classification of Internal and Outstand parts according to EN 1993-1-1 Table 5.2 Sheet 1 & 2

Id	Type	c [mm]	t [mm]	σ_1 [kN/m ²]	σ_2 [kN/m ²]	ψ [-]	k_{σ} [-]	α [-]	c/t [-]	Class 1 Limit [-]	Class 2 Limit [-]	Class 3 Limit [-]	Class
1	I	42	6	1,132e+05	1,037e+05	0,92		1,00	7,00	22,78	27,66	31,85	1
3	I	82	6	1,023e+05	1,023e+05	1,00		1,00	13,67	22,78	27,66	30,92	1
5	I	42	6	1,037e+05	1,132e+05	0,92		1,00	7,00	22,78	27,66	31,85	1
7	I	82	6	1,146e+05	1,146e+05	1,00		1,00	13,67	22,78	27,66	30,92	1

Note: The Classification limits have been set according to Semi-Comp+.

The cross-section is classified as Class 1

Compression check

According to EN 1993-1-1 article 6.2.4 and formula (6.9)

Cross-section area	A	1,6830e-03	m ²
Compression resistance	$N_{c,Rd}$	597,47	kN
Unity check		0,31	-

Bending moment check for M_z

According to EN 1993-1-1 article 6.2.5 and formula (6.12),(6.13)

Plastic section modulus	$W_{pl,z}$	3,6640e-05	m ³
Plastic bending moment	$M_{pl,z,Rd}$	13,01	kNm
Unity check		0,02	-

Shear check for V_y

According to EN 1993-1-1 article 6.2.6 and formula (6.17)

Shear correction factor	η	1,20	
Shear area	A_v	6,3112e-04	m ²
Plastic shear resistance for V_y	$V_{pl,y,Rd}$	129,35	kN
Unity check		0,00	-

Torsion check

According to EN 1993-1-1 article 6.2.7 and formula (6.23)

Index of fibre	Fibre	1	
Total torsional moment	T_{Ed}	0,4	MPa
Elastic shear resistance	T_{Rd}	205,0	MPa
Unity check		0,00	-

Note: The unity check for torsion is lower than the limit value of 0,05. Therefore torsion is considered as insignificant and is ignored in the combined checks.

Combined bending, axial force and shear force check

According to EN 1993-1-1 article 6.2.9.1 and formula (6.31)

Design plastic moment resistance reduced due to N_{Ed}	$M_{N,z,Rd}$	10,55	kNm
Unity check		0,02	-

Note: Since the shear forces are less than half the plastic shear resistances their effect on the moment resistances is neglected.

The member satisfies the section check.

....:STABILITY CHECK:....

Classification for member buckling design

Decisive position for stability classification: 1,700 m

Classification according to EN 1993-1-1 article 5.5.2

Classification of Internal and Outstand parts according to EN 1993-1-1 Table 5.2 Sheet 1 & 2

Id	Type	c [mm]	t [mm]	σ_1 [kN/m ²]	σ_2 [kN/m ²]	Ψ [-]	k_{σ} [-]	α [-]	c/t [-]	Class 1 Limit [-]	Class 2 Limit [-]	Class 3 Limit [-]	Class
1	I	42	6	1,004e+05	1,162e+05	0,86		1,00	7,00	22,78	27,66	32,45	1
3	I	82	6	1,184e+05	1,184e+05	1,00		1,00	13,67	22,78	27,66	30,92	1
5	I	42	6	1,162e+05	1,004e+05	0,86		1,00	7,00	22,78	27,66	32,45	1
7	I	82	6	9,810e+04	9,810e+04	1,00		1,00	13,67	22,78	27,66	30,92	1

Note: The Classification limits have been set according to Semi-Comp+. The cross-section is classified as Class 1

Flexural Buckling check

According to EN 1993-1-1 article 6.3.1.1 and formula (6.46)

Buckling parameters		yy	zz	
Sway type		sway	non-sway	
System length	L	1,700	1,700	m
Buckling factor	k	1,00	0,59	
Buckling length	l_{cr}	1,700	1,011	m
Critical Euler load	N_{cr}	1472,35	1850,90	kN
Slenderness	λ	48,67	43,41	
Relative slenderness	λ_{rel}	0,64	0,57	
Limit slenderness	$\lambda_{rel,0}$	0,20	0,20	
Buckling curve	a	a	a	
Imperfection	α	0,21	0,21	
Reduction factor	χ	0,88	0,90	
Buckling resistance	$N_{b,Rd}$	523,02	538,72	kN

Flexural Buckling verification			
Cross-section area	A	1,6830e-03	m ²
Buckling resistance	$N_{b,Rd}$	523,02	kN
Unity check		0,35	-

Torsional(-Flexural) Buckling check

According to EN 1993-1-1 article 6.3.1.1 and formula (6.46)

Note: The cross-section concerns a RHS section which is not susceptible to Torsional(-Flexural) Buckling.

Bending and axial compression check

According to EN 1993-1-1 article 6.3.3 and formula (6.61),(6.62)

Bending and axial compression check parameters			
Interaction method		alternative method 1	
Cross-section area	A	1,6830e-03	m ²
Plastic section modulus	$W_{pl,z}$	3,6640e-05	m ³
Design compression force	N_{Ed}	182,51	kN
Design bending moment (maximum)	$M_{y,Ed}$	0,00	kNm
Design bending moment (maximum)	$M_{z,Ed}$	0,34	kNm
Characteristic compression resistance	N_{Rk}	597,47	kN
Characteristic moment resistance	$M_{z,Rk}$	13,01	kNm
Reduction factor	χ_y	0,88	
Reduction factor	χ_z	0,90	
Reduction factor	χ_{LT}	1,00	
Interaction factor	k_{yz}	0,59	
Interaction factor	k_{zz}	0,98	

Maximum moment $M_{y,Ed}$ is derived from beam B78 position 0,000 m.

Maximum moment $M_{z,Ed}$ is derived from beam B78 position 1,700 m.

Interaction method 1 parameters			
Critical Euler load	$N_{cr,y}$	1472,35	kN
Critical Euler load	$N_{cr,z}$	1850,90	kN
Elastic critical load	$N_{cr,T}$	99816,17	kN
Plastic section modulus	$W_{pl,y}$	5,2540e-05	m ³
Elastic section modulus	$W_{el,y}$	4,1060e-05	m ³
Plastic section modulus	$W_{pl,z}$	3,6640e-05	m ³
Elastic section modulus	$W_{el,z}$	3,0400e-05	m ³
Second moment of area	I_y	2,0530e-06	m ⁴
Second moment of area	I_z	9,1200e-07	m ⁴
Torsional constant	I_t	2,1644e-06	m ⁴
Method for equivalent moment factor $C_{mz,0}$		Table A.2 Line 2 (General)	
Design bending moment (maximum)	$M_{z,Ed}$	0,34	kNm
Maximum relative deflection	δ_y	-0,2	mm
Equivalent moment factor	$C_{mz,0}$	0,94	
Factor	μ_y	0,98	
Factor	μ_z	0,99	
Factor	a_{LT}	0,00	
Critical moment for uniform bending	$M_{cr,0}$	339,14	kNm
Relative slenderness	$\lambda_{rel,0}$	0,23	
Equivalent moment factor	C_{mz}	0,94	
Factor	c_{LT}	0,00	
Factor	e_{LT}	0,00	
Factor	w_y	1,28	
Factor	w_z	1,21	
Factor	η_{pl}	0,31	
Maximum relative slenderness	$\lambda_{rel,max}$	0,64	
Factor	C_{yz}	1,00	
Factor	C_{zz}	1,05	

Unity check (6.61) = 0,35 + 0,00 + 0,02 = 0,36 -

Unity check (6.62) = 0,34 + 0,00 + 0,03 = 0,36 -

The member satisfies the stability check.

Student version

Student version

7.3. Krovne podrožnice – Pozicija 7

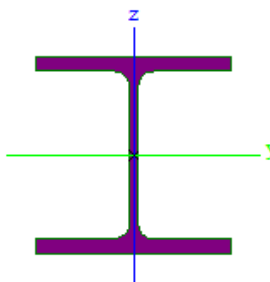
Name	podroznice		
Type	HEB240		
Source description	Profil Arbed / Structural shapes / Edition Octobre 1995		
Item material	S 355		
Fabrication	rolled		
Flexural buckling y-y	b		
Flexural buckling z-z	c		
Lateral torsional buckling	Default		
Use 2D FEM analysis	x		
			
A [m ²]	1,0600e-02		
A _{y, z} [m ²]	7,8218e-03		2,5536e-03
I _{y, z} [m ⁴]	1,1260e-04		3,9230e-05
I _w [m ⁶], I _t [m ⁴]	4,8695e-07		1,0270e-06
W _{el} y, z [m ³]	9,3830e-04		3,2690e-04
W _{pl} y, z [m ³]	1,0530e-03		4,9840e-04
d y, z [mm]	0		0
c YUCS, ZUCS [mm]	120		120
α [deg]	0,00		
A _{L, D} [m ² /m]	1,3800e+00		1,3838e+00
M _{pl} +, - [Nm]	3,74e+05		3,74e+05
M _{pz} +, - [Nm]	1,77e+05		1,77e+05

Slika 7.3.1. Karakteristike poprečnog presjeka krovne podrožnice

EC-EN 1993 Steel check ULS

Values: UC Overall
 Linear calculation
 Combination: ULS-Set B (auto)
 Coordinate system: Principal
 Extreme 1D: Cross-section
 Selection: All
 Filter: Cross-section = podroznice -
 HEB240

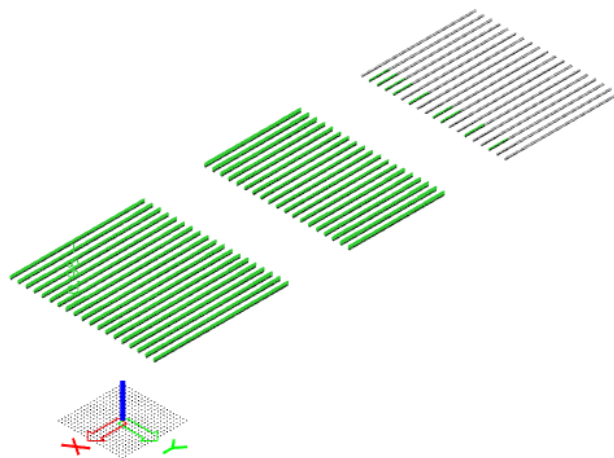

Slika 7.3.2. Prikaz iskoristivosti krovne podrožnice

1D internal forces

Values: M_x
Linear calculation
Combination: ULS-Set B (auto)
Coordinate system: Principal
Extreme 1D: Global
Selection: All
Filter: Cross-section = podroznice - HEB240

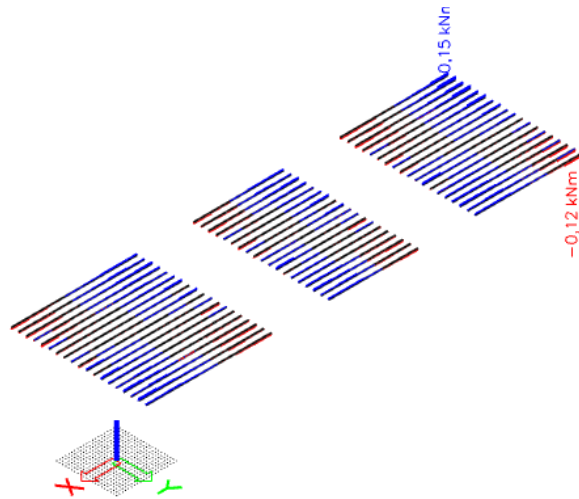

Slika 7.3.3.Moment M_x

1D internal forces

Values: M_y
Linear calculation
Combination: ULS-Set B (auto)
Coordinate system: Principal
Extreme 1D: Global
Selection: All
Filter: Cross-section = podroznice - HEB240

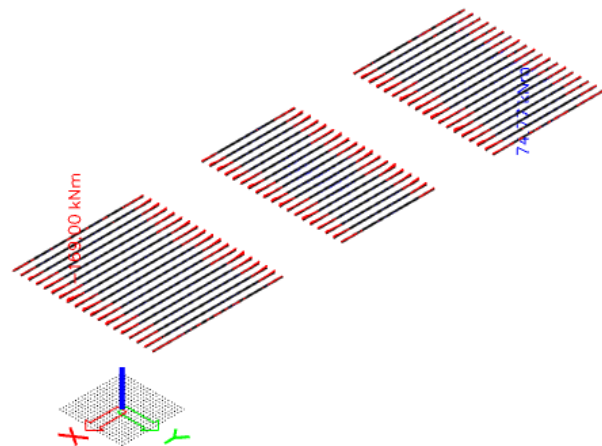

Slika 7.3.4.Moment M_y

1D internal forces

Values: M_z
Linear calculation
Combination: ULS-Set B (auto)
Coordinate system: Principal
Extreme 1D: Global
Selection: All
Filter: Cross-section = podroznice - HEB240

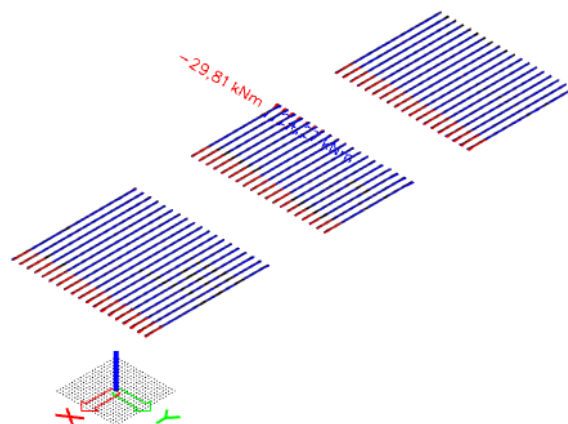

Slika 7.3.5.Moment M_z

1D internal forces

Values: V_y
Linear calculation
Combination: ULS-Set B (auto)
Coordinate system: Principal
Extreme 1D: Global
Selection: All
Filter: Cross-section = podroznice -
HEB240

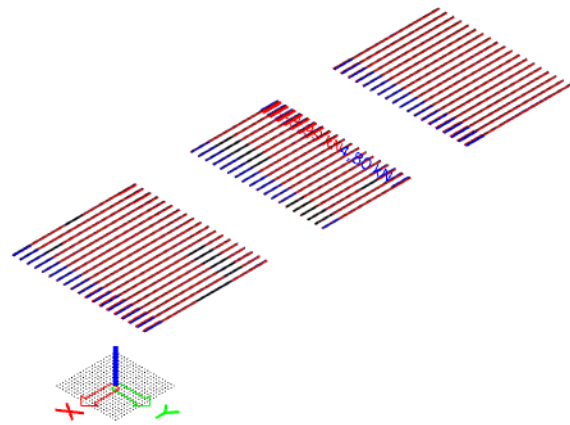

Slika 7.3.6. Poprečna sila V_y

1D internal forces

Values: V_z
Linear calculation
Combination: ULS-Set B (auto)
Coordinate system: Principal
Extreme 1D: Global
Selection: All
Filter: Cross-section = podroznice -
HEB240

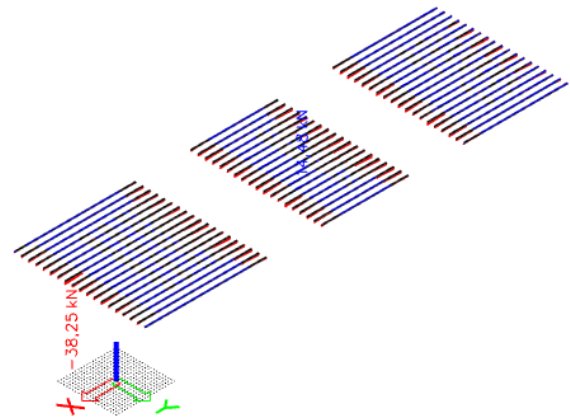

Slika 7.3.7. Poprečna sila V_z

1D internal forces

Values: N
Linear calculation
Combination: ULS-Set B (auto)
Coordinate system: Principal
Extreme 1D: Global
Selection: All
Filter: Cross-section = podroznice -
HEB240

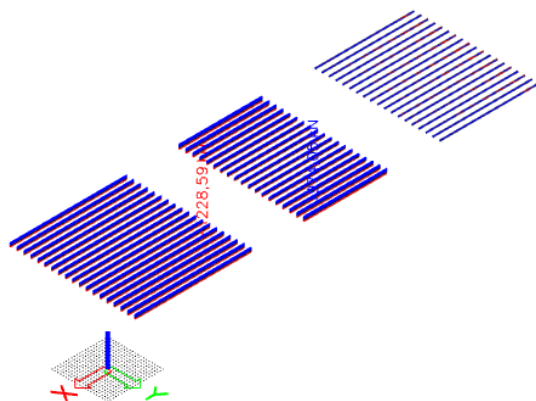

Slika 7.3.8. Uzdužna sila N

EC-EN 1993 Steel check ULS

Linear calculation
 Combination: ULS-Set B (auto)
 Coordinate system: Principal
 Extreme 1D: Cross-section
 Selection: All
 Filter: Cross-section = podroznice - HEB240

EN 1993-1-1 Code Check

National annex: Standard EN

Member B2622 6,000 / 6,000 m HEB240 S 355 ULS-Set B (auto) 0,98 -

Combination key
 ULS-Set B (auto) / 1.35*LC1 + 1.50*snijeg + 1.35*dodatno stalno + 0.90*3DWind10 + 1.50*temperatura +

Partial safety factors	
γ_{M0} for resistance of cross-sections	1,00
γ_{M1} for resistance to instability	1,00
γ_{M2} for resistance of net sections	1,25

Material			
Yield strength	f_y	355,0	MPa
Ultimate strength	f_u	490,0	MPa
Fabrication		Rolled	

....:SECTION CHECK:....

The critical check is on position 6,000 m

Internal forces		Calculated	Unit
Normal force	N_{Ed}	-921,71	kN
Shear force	$V_{y,Ed}$	0,55	kN
Shear force	$V_{z,Ed}$	-36,45	kN
Torsion	T_{Ed}	-0,02	kNm
Bending moment	$M_{y,Ed}$	-162,80	kNm
Bending moment	$M_{z,Ed}$	1,82	kNm

Classification for cross-section design

Classification according to EN 1993-1-1 article 5.5.2

Classification of Internal and Outstand parts according to EN 1993-1-1 Table 5.2 Sheet 1 & 2.

Id	Type	c [mm]	t [mm]	σ_1 [kN/m ²]	σ_2 [kN/m ²]	ψ [-]	κ_0 [-]	α [-]	c/t [-]	Class 1 Limit [-]	Class 2 Limit [-]	Class 3 Limit [-]	Class
1	SO	94	17	2,469e+05	2,426e+05	0,98	0,44	1,00	5,53	7,32	8,14	11,30	1
3	SO	94	17	2,494e+05	2,537e+05	0,98	0,43	1,00	5,53	7,32	8,14	11,22	1
4	I	164	10	2,055e+05	-3,159e+04	-0,15		1,00	16,40	22,78	27,66	51,56	1
5	SO	94	17	-7,303e+04	-6,867e+04								
7	SO	94	17	-7,545e+04	-7,981e+04								

Note: The Classification limits have been set according to Semi-Comp+.
 The cross-section is classified as Class 1

Compression check

According to EN 1993-1-1 article 6.2.4 and formula (6.9)

Cross-section area	A	1,0600e-02	m ²
Compression resistance	$N_{c,Rd}$	3763,00	kN
Unity check		0,24	-

Bending moment check for M_y

According to EN 1993-1-1 article 6.2.5 and formula (6.12),(6.13)

Plastic section modulus	$W_{pl,y}$	1,0530e-03	m ³
Plastic bending moment	$M_{pl,y,Rd}$	373,81	kNm
Unity check		0,44	-

Bending moment check for M_z

According to EN 1993-1-1 article 6.2.5 and formula (6.12),(6.13)

Plastic section modulus	$W_{pl,z}$	4,9840e-04	m ³
Plastic bending moment	$M_{pl,z,Rd}$	176,93	kNm
Unity check		0,01	-

Shear check for V_y

According to EN 1993-1-1 article 6.2.6 and formula (6.17)

Shear correction factor	η	1,20	
Shear area	A_v	8,4700e-03	m ²
Plastic shear resistance for V_y	$V_{pl,y,Rd}$	1736,01	kN
Unity check		0,00	-

Shear check for V_z

According to EN 1993-1-1 article 6.2.6 and formula (6.17)

Shear correction factor	η	1,20	
Shear area	A_v	3,3240e-03	m ²
Plastic shear resistance for V_z	$V_{pl,z,Rd}$	681,28	kN
Unity check		0,05	-

Torsion check

According to EN 1993-1-1 article 6.2.7 and formula (6.23)

Index of fibre	Fibre	2	
Total torsional moment	T_{Ed}	0,3	MPa
Elastic shear resistance	T_{Rd}	205,0	MPa
Unity check		0,00	-

Note: The unity check for torsion is lower than the limit value of 0,05. Therefore torsion is considered as insignificant and is ignored in the combined checks.

Combined bending, axial force and shear force check

According to EN 1993-1-1 article 6.2.9.1 and formula (6.41)

Design plastic moment resistance reduced due to N_{Ed}	$M_{N,y,Rd}$	318,96	kNm
Exponent of bending ratio y	α	2,00	
Design plastic moment resistance reduced due to N_{Ed}	$M_{N,z,Rd}$	176,87	kNm
Exponent of bending ratio z	β	1,22	

Unity check (6.41) = 0,26 + 0,00 = 0,26 -

Note: Since the shear forces are less than half the plastic shear resistances their effect on the moment resistances is neglected.

The member satisfies the section check.

....:STABILITY CHECK:....

Classification for member buckling design

Decisive position for stability classification: 6,000 m

Classification according to EN 1993-1-1 article 5.5.2

Classification of Internal and Outstand parts according to EN 1993-1-1 Table 5.2 Sheet 1 & 2

Id	Type	c [mm]	t [mm]	σ_1 [kN/m ²]	σ_2 [kN/m ²]	Ψ [-]	k_σ [-]	α [-]	c/t [-]	Class 1 Limit [-]	Class 2 Limit [-]	Class 3 Limit [-]	Class
1	SO	94	17	2,469e+05	2,426e+05	0,98	0,44	1,00	5,53	7,32	8,14	11,30	1
3	SO	94	17	2,494e+05	2,537e+05	0,98	0,43	1,00	5,53	7,32	8,14	11,22	1
4	I	164	10	2,055e+05	-3,159e+04	-0,15		1,00	16,40	22,78	27,66	51,56	1
5	SO	94	17	-7,303e+04	-6,867e+04								
7	SO	94	17	-7,545e+04	-7,981e+04								

Note: The Classification limits have been set according to Semi-Comp+. The cross-section is classified as Class 1

Flexural Buckling check

According to EN 1993-1-1 article 6.3.1.1 and formula (6.46)

Buckling parameters		yy	zz	
Sway type		sway	non-sway	
System length	L	6,000	6,000	m
Buckling factor	k	1,00	1,00	
Buckling length	l_{cr}	6,000	6,000	m
Critical Euler load	N_{cr}	6482,69	2258,58	kN
Slenderness	λ	58,22	98,63	
Relative slenderness	λ_{rel}	0,76	1,29	
Limit slenderness	$\lambda_{rel,0}$	0,20	0,20	
Buckling curve		b	c	
Imperfection	α	0,34	0,49	
Reduction factor	χ	0,75	0,39	
Buckling resistance	$N_{b,Rd}$	2813,41	1477,87	kN

Flexural Buckling verification

Cross-section area	A	1,0600e-02	m ²
Buckling resistance	$N_{b,Rd}$	1477,87	kN
Unity check		0,62	-

Torsional(-Flexural) Buckling check

According to EN 1993-1-1 article 6.3.1.1 and formula (6.46)

Note: For this I-section the Torsional(-Flexural) buckling resistance is higher than the resistance for Flexural buckling. Therefore Torsional(-Flexural) buckling is not printed on the output.

Laterai Torsional Buckling check

According to EN 1993-1-1 article 6.3.2.1 & 6.3.2.3 and formula (6.54)

LTB parameters			
Method for LTB curve		Alternative case	
Plastic section modulus	$W_{pl,y}$	1,0530e-03	m^3
Elastic critical moment	M_{cr}	1039,73	kNm
Relative slenderness	$\lambda_{rel,LT}$	0,60	
Limit slenderness	$\lambda_{rel,LT,0}$	0,40	

Note: The slenderness or bending moment is such that Lateral Torsional Buckling effects may be ignored according to EN 1993-1-1 article 6.3.2.2(4).

Mcr parameters			
LTB length	l_{LT}	6,000	m
Influence of load position		no influence	
Correction factor	k	1,00	
Correction factor	k_{W}	1,00	
LTB moment factor	C_1	2,08	
LTB moment factor	C_2	0,03	
LTB moment factor	C_3	1,00	
Shear centre distance	d_z	0	mm
Distance of load application	Z_g	0	mm
Mono-symmetry constant	β_y	0	mm
Mono-symmetry constant	z_1	0	mm

Note: C parameters are determined according to ECSS 119 2006 / Galea 2002.

Bending and axial compression check

According to EN 1993-1-1 article 6.3.3 and formula (6.61),(6.62)

Bending and axial compression check parameters			
Interaction method		alternative method 1	
Cross-section area	A	1,0600e-02	m^2
Plastic section modulus	$W_{pl,y}$	1,0530e-03	m^3
Plastic section modulus	$W_{pl,z}$	4,9840e-04	m^3
Design compression force	N_{Ed}	921,71	kN
Design bending moment (maximum)	$M_{y,Ed}$	-162,80	kNm
Design bending moment (maximum)	$M_{z,Ed}$	1,82	kNm
Characteristic compression resistance	N_{Rk}	3763,00	kN
Characteristic moment resistance	$M_{y,Rk}$	373,81	kNm
Characteristic moment resistance	$M_{z,Rk}$	176,93	kNm
Reduction factor	χ_y	0,75	
Reduction factor	χ_z	0,39	
Modified reduction factor	$\chi_{LT,mod}$	1,00	
Interaction factor	k_{yy}	1,49	
Interaction factor	k_{yz}	0,53	
Interaction factor	k_{zy}	0,77	
Interaction factor	k_{zz}	0,47	

Maximum moment $M_{y,Ed}$ is derived from beam B2622 position 6,000 m.

Maximum moment $M_{z,Ed}$ is derived from beam B2622 position 6,000 m.

Interaction method 1 parameters			
Critical Euler load	$N_{cr,y}$	6482,69	kN
Critical Euler load	$N_{cr,z}$	2258,58	kN
Elastic critical load	$N_{cr,T}$	7748,40	kN
Plastic section modulus	$W_{pl,y}$	1,0530e-03	m^3
Elastic section modulus	$W_{el,y}$	9,3830e-04	m^3
Plastic section modulus	$W_{pl,z}$	4,9840e-04	m^3
Elastic section modulus	$W_{el,z}$	3,2690e-04	m^3
Second moment of area	I_y	1,1260e-04	m^4
Second moment of area	I_z	3,9230e-05	m^4
Torsional constant	I_t	1,0270e-06	m^4
Method for equivalent moment factor $C_{my,0}$		Table A.2 Line 2 (General)	
Design bending moment (maximum)	$M_{y,Ed}$	-162,80	kNm
Maximum relative deflection	δ_z	12,5	mm
Equivalent moment factor	$C_{my,0}$	0,93	
Method for equivalent moment factor $C_{mz,0}$		Table A.2 Line 1 (Linear)	
Ratio of end moments	ψ_z	-0,82	
Equivalent moment factor	$C_{mz,0}$	0,45	
Factor	μ_y	0,96	
Factor	μ_z	0,70	
Factor	ϵ_y	2,00	
Factor	a_{LT}	0,99	
Critical moment for uniform bending	$M_{cr,0}$	500,67	kNm
Relative slenderness	$\lambda_{rel,0}$	0,86	

Interaction method 1 parameters		
Limit relative slenderness	$\lambda_{rel,0,lim}$	0,24
Equivalent moment factor	C_{my}	0,97
Equivalent moment factor	C_{mz}	0,45
Equivalent moment factor	C_{mLT}	1,29
Factor	b_{LT}	0,00
Factor	c_{LT}	0,43
Factor	d_{LT}	0,01
Factor	e_{LT}	0,23
Factor	w_y	1,12
Factor	w_z	1,50
Factor	η_{pl}	0,24
Maximum relative slenderness	$\lambda_{rel,max}$	1,29
Factor	C_{yy}	0,94
Factor	C_{yz}	0,96
Factor	C_{zy}	0,69
Factor	C_{zz}	1,14

Unity check (6.61) = 0,33 + 0,65 + 0,01 = 0,98 -

Unity check (6.62) = 0,62 + 0,34 + 0,00 = 0,97 -

Shear Buckling check

According to EN 1993-1-5 article 5 & 7.1 and formula (5.10) & (7.1)

Shear Buckling parameters		
Buckling field length	a	6,000 m
Web		unstiffened
Web height	h_w	206 mm
Web thickness	t	10 mm
Material coefficient	ϵ	0,81
Shear correction factor	η	1,20

Shear Buckling verification		
Web slenderness	h_w/t	20,60
Web slenderness limit		48,82

Note: The web slenderness is such that Shear Buckling effects may be ignored according to EN 1993-1-5 article 5.1(2).

The member satisfies the stability check.

7.4. Vanjske grede – Pozicija 8

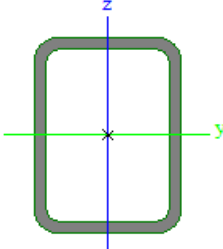
Name	grede vanka	
Type	CFRHS80X60X5	
Source description	Rautaruukki Oyj / Structural Hollow Sections EN10219 / Ed.2007	
Item material	S 355	
Fabrication	rolled	
Flexural buckling y-y	a	
Flexural buckling z-z	a	
Lateral torsional buckling	Default	
Use 2D FEM analysis	x	
		
A [m ²]	1,2360e-03	
A _{y, z} [m ²]	5,2904e-04	7,0539e-04
I _{y, z} [m ⁴]	1,0328e-06	6,5660e-07
I _w [m ⁶], I _t [m ⁴]	6,7200e-10	1,3553e-06
W _{el, y, z} [m ³]	2,5820e-05	2,1890e-05
W _{pl, y, z} [m ³]	3,2240e-05	2,6380e-05
d _{y, z} [mm]	0	0
c _{YUCS, ZUCS} [mm]	30	40
α [deg]	0,00	
A _{L, D} [m ² /m]	2,6300e-01	4,9413e-01
M _{pl, y, z} +, - [Nm]	1,14e+04	1,14e+04
M _{pl, z, y} +, - [Nm]	9,35e+03	9,35e+03

Slika 7.4.1. Karakteristike poprečnog presjeka vanjskih greda

EC-EN 1993 Steel check ULS
 Values: UC Overall
 Linear calculation
 Combination: ULS-Set B (auto)
 Coordinate system: Principal
 Extreme 1D: Cross-section
 Selection: All
 Filter: Cross-section = grede vanka -
 CFRHS80X60X5

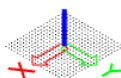
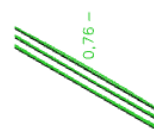

Slika 7.4.2. Prikaz iskoristivosti vanjskih greda

1D internal forces

Values: M_x
Linear calculation
Combination: ULS-Set B (auto)
Coordinate system: Principal
Extreme 1D: Global
Selection: All
Filter: Cross-section = grede vanka - CFRHS80X60X5

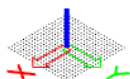
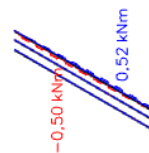

Slika 7.4.3..Moment M_x

1D internal forces

Values: M_y
Linear calculation
Combination: ULS-Set B (auto)
Coordinate system: Principal
Extreme 1D: Global
Selection: All
Filter: Cross-section = grede vanka - CFRHS80X60X5

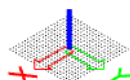
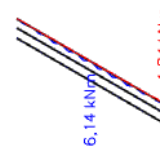

Slika 7.4.4.Moment M_y

1D internal forces

Values: M_z
Linear calculation
Combination: ULS-Set B (auto)
Coordinate system: Principal
Extreme 1D: Global
Selection: All
Filter: Cross-section = grede vanka - CFRHS80X60X5

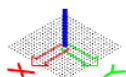
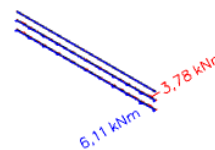

Slika 7.4.5.Moment M_z

1D internal forces

Values: V_y
Linear calculation
Combination: ULS-Set B (auto)
Coordinate system: Principal
Extreme 1D: Global
Selection: All
Filter: Cross-section = grede vanka -
CFRHS80X60X5

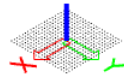
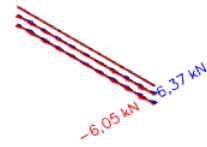

Slika 7.4.6. Poprečna sila V_y

1D internal forces

Values: V_z
Linear calculation
Combination: ULS-Set B (auto)
Coordinate system: Principal
Extreme 1D: Global
Selection: All
Filter: Cross-section = grede vanka -
CFRHS80X60X5

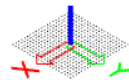
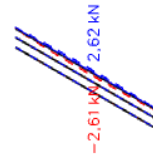

Slika 7.4.7. Poprečna sila V_z

1D internal forces

Values: N
Linear calculation
Combination: ULS-Set B (auto)
Coordinate system: Principal
Extreme 1D: Global
Selection: All
Filter: Cross-section = grede vanka -
CFRHS80X60X5

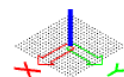
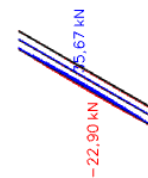

Slika 7.4.8. Uzdužna sila N

EC-EN 1993 Steel check ULS

Linear calculation
 Combination: ULS-Set B (auto)
 Coordinate system: Principal
 Extreme 1D: Cross-section
 Selection: All
 Filter: Cross-section = grede vanka - CFRHS80X60X5

EN 1993-1-1 Code Check

National annex: Standard EN

Member B2570	2,500 / 5,000 m	CFRHS80X60X5	S 355	ULS-Set B (auto)	0,76 -
--------------	-----------------	--------------	-------	------------------	--------

Combination key	
ULS-Set B (auto) / 1.35*LC1 + 1.50*snijeg + 1.35*dodatno stalno + 1.50*3DWind6 + 0.90*temperatura -	

Partial safety factors	
γ_{M0} for resistance of cross-sections	1,00
γ_{M1} for resistance to instability	1,00
γ_{M2} for resistance of net sections	1,25

Material			
Yield strength	f_y	355,0	MPa
Ultimate strength	f_u	490,0	MPa
Fabrication		Rolled	

....:SECTION CHECK:....

The critical check is on position 2,500 m

Internal forces	Calculated	Unit
Normal force	N_{Ed}	-13,33 kN
Shear force	$V_{y,Ed}$	0,46 kN
Shear force	$V_{z,Ed}$	2,29 kN
Torsion	T_{Ed}	0,46 kNm
Bending moment	$M_{y,Ed}$	6,14 kNm
Bending moment	$M_{z,Ed}$	0,31 kNm

Classification for cross-section design

Classification according to EN 1993-1-1 article 5.5.2

Classification of Internal and Outstand parts according to EN 1993-1-1 Table 5.2 Sheet 1 & 2.

Id	Type	c [mm]	t [mm]	σ_1 [kN/m ²]	σ_2 [kN/m ²]	ψ [-]	κ_0 [-]	α [-]	c/t [-]	Class 1 Limit [-]	Class 2 Limit [-]	Class 3 Limit [-]	Class
1	I	45	5	-2,228e+05	-2,014e+05								
3	I	65	5	-1,693e+05	2,170e+05	-0,78		0,56	13,00	49,06	57,33	80,88	1
5	I	45	5	2,444e+05	2,230e+05	0,91		1,00	9,00	22,78	27,66	31,88	1
7	I	65	5	1,909e+05	-1,955e+05	-1,02		0,49	13,00	59,27	68,33	103,29	1

Note: The Classification limits have been set according to Semi-Comp+.
 The cross-section is classified as Class 1

Compression check

According to EN 1993-1-1 article 6.2.4 and formula (6.9)

Cross-section area	A	1,2360e-03	m ²
Compression resistance	$N_{c,Rd}$	438,78	kN
Unity check		0,03	-

Bending moment check for M_y

According to EN 1993-1-1 article 6.2.5 and formula (6.12),(6.13)

Plastic section modulus	$W_{pl,y}$	3,2240e-05	m ³
Plastic bending moment	$M_{pl,y,Rd}$	11,45	kNm
Unity check		0,54	-

Bending moment check for M_z

According to EN 1993-1-1 article 6.2.5 and formula (6.12),(6.13)

Plastic section modulus	$W_{pl,z}$	2,6380e-05	m ³
Plastic bending moment	$M_{pl,z,Rd}$	9,36	kNm
Unity check		0,03	-

Shear check for V_y

According to EN 1993-1-1 article 6.2.6 and formula (6.17)

Shear correction factor	η	1,20	
Shear area	A_v	5,2971e-04	m ²
Plastic shear resistance for V_y	$V_{pl,y,Rd}$	108,57	kN
Unity check		0,00	-

Shear check for V_z

According to EN 1993-1-1 article 6.2.6 and formula (6.17)

Shear correction factor	η	1,20	
Shear area	A_v	7,0629e-04	m ²
Plastic shear resistance for V_z	$V_{pl,z,Rd}$	144,76	kN
Unity check		0,02	-

Torsion check

According to EN 1993-1-1 article 6.2.7 and formula (6.23)

Index of fibre	Fibre	1	
Total torsional moment	T_{Ed}	11,1	MPa
Elastic shear resistance	T_{Rd}	205,0	MPa
Unity check		0,05	-

Combined Shear and Torsion check for V_y and $\tau_{t,Ed}$

According to EN 1993-1-1 article 6.2.6 & 6.2.7 and formula (6.25),(6.28)

Plastic shear resistance for V_y and T_{Ed}	$V_{pl,T,y,Rd}$	102,71	kN
Unity check		0,00	-

Combined Shear and Torsion check for V_z and $\tau_{t,Ed}$

According to EN 1993-1-1 article 6.2.6 & 6.2.7 and formula (6.25),(6.28)

Plastic shear resistance for V_z and T_{Ed}	$V_{pl,T,z,Rd}$	136,95	kN
Unity check		0,02	-

Combined bending, axial force and shear force check

According to EN 1993-1-1 article 6.2.9.1 and formula (6.41)

Design plastic moment resistance reduced due to N_{Ed}	$M_{N,y,Rd}$	11,45	kNm
Exponent of bending ratio y	α	1,66	
Design plastic moment resistance reduced due to N_{Ed}	$M_{N,z,Rd}$	9,36	kNm
Exponent of bending ratio z	β	1,66	

Unity check (6.41) = 0,35 + 0,00 = 0,36 -

Note: Since the shear forces are less than half the plastic shear resistances their effect on the moment resistances is neglected.

The member satisfies the section check.

....:STABILITY CHECK:....

Classification for member buckling design

Decisive position for stability classification: 2,500 m

Classification according to EN 1993-1-1 article 5.5.2

Classification of Internal and Outstand parts according to EN 1993-1-1 Table 5.2 Sheet 1 & 2

Id	Type	c [mm]	t [mm]	σ_1 [kN/m ²]	σ_2 [kN/m ²]	Ψ [-]	k_{σ} [-]	α [-]	c/t [-]	Class 1 Limit [-]	Class 2 Limit [-]	Class 3 Limit [-]	Class
1	I	45	5	-2,228e+05	-2,014e+05								
3	I	65	5	-1,693e+05	2,170e+05	-0,78		0,56	13,00	49,06	57,33	80,88	1
5	I	45	5	2,444e+05	2,230e+05	0,91		1,00	9,00	22,78	27,66	31,88	1
7	I	65	5	1,909e+05	-1,955e+05	-1,02		0,49	13,00	59,27	68,33	103,29	1

Note: The Classification limits have been set according to Semi-Comp+.

The cross-section is classified as Class 1

Flexural Buckling check

According to EN 1993-1-1 article 6.3.1.1 and formula (6.46)

Buckling parameters		yy	zz	
Sway type		sway	non-sway	
System length	L	5,000	2,500	m
Buckling factor	k	1,00	0,62	
Buckling length	l_{cr}	5,000	1,554	m
Critical Euler load	N_{cr}	85,62	563,33	kN
Slenderness	λ	172,97	67,44	
Relative slenderness	λ_{rel}	2,26	0,88	
Limit slenderness	$\lambda_{rel,0}$	0,20	0,20	
Buckling curve		a	a	
Imperfection	α	0,21	0,21	
Reduction factor	χ	0,18	0,75	
Buckling resistance	$N_{b,Rd}$	77,65	327,03	kN

Flexural Buckling verification

Cross-section area	A	1,2360e-03	m ²
Buckling resistance	$N_{b,Rd}$	77,65	kN
Unity check		0,17	-

Torsional(-Flexural) Buckling check

According to EN 1993-1-1 article 6.3.1.1 and formula (6.46)

Note: The cross-section concerns a RHS section which is not susceptible to Torsional(-Flexural) Buckling.

Lateral Torsional Buckling check

According to EN 1993-1-1 article 6.3.2.1

Note: The cross-section concerns an RHS section with $h / b < 10 / \lambda_{rel,z}$. This section is thus not susceptible to Lateral Torsional Buckling.

Bending and axial compression check

According to EN 1993-1-1 article 6.3.3 and formula (6.61),(6.62)

Bending and axial compression check parameters			
Interaction method		alternative method 1	
Cross-section area	A	1,2360e-03	m ²
Plastic section modulus	W _{pl,y}	3,2240e-05	m ³
Plastic section modulus	W _{pl,z}	2,6380e-05	m ³
Design compression force	N _{Ed}	13,33	kN
Design bending moment (maximum)	M _{y,Ed}	6,13	kNm
Design bending moment (maximum)	M _{z,Ed}	0,31	kNm
Characteristic compression resistance	N _{Rk}	438,78	kN
Characteristic moment resistance	M _{y,Rk}	11,45	kNm
Characteristic moment resistance	M _{z,Rk}	9,36	kNm
Reduction factor	χ _y	0,18	
Reduction factor	χ _z	0,75	
Reduction factor	χ _{LT}	1,00	
Interaction factor	k _{yy}	1,05	
Interaction factor	k _{yz}	0,61	
Interaction factor	k _{zy}	0,83	
Interaction factor	k _{zz}	1,05	

Maximum moment M_{y,Ed} is derived from beam B2570 position 2,500 m.

Maximum moment M_{z,Ed} is derived from beam B2570 position 2,500 m.

Interaction method 1 parameters			
Critical Euler load	N _{cr,y}	85,62	kN
Critical Euler load	N _{cr,z}	563,33	kN
Elastic critical load	N _{cr,T}	80251,02	kN
Plastic section modulus	W _{pl,y}	3,2240e-05	m ³
Elastic section modulus	W _{el,y}	2,5820e-05	m ³
Plastic section modulus	W _{pl,z}	2,6380e-05	m ³
Elastic section modulus	W _{el,z}	2,1890e-05	m ³
Second moment of area	I _y	1,0329e-06	m ⁴
Second moment of area	I _z	6,5660e-07	m ⁴
Torsional constant	I _t	1,3553e-06	m ⁴
Method for equivalent moment factor		Table A.2 Line 3 (Point load)	
Equivalent moment factor	C _{my,0}	0,97	
Method for equivalent moment factor		Table A.2 Line 2 (General)	
Equivalent moment factor	C _{mz,0}		
Design bending moment (maximum)	M _{z,Ed}	0,31	kNm
Maximum relative deflection	δ _y	0,3	mm
Equivalent moment factor	C _{mz,0}	0,98	
Factor	μ _y	0,87	
Factor	μ _z	0,99	
Factor	ε _y	22,01	
Factor	a _{LT}	0,00	
Critical moment for uniform bending	M _{cr,0}	154,54	kNm
Relative slenderness	λ _{rel,0}	0,27	
Limit relative slenderness	λ _{rel,0,lim}	0,26	
Equivalent moment factor	C _{my}	0,97	
Equivalent moment factor	C _{mz}	0,98	
Equivalent moment factor	C _{mLT}	1,00	
Factor	b _{LT}	0,00	
Factor	c _{LT}	0,00	
Factor	d _{LT}	0,00	
Factor	e _{LT}	0,00	
Factor	w _y	1,25	
Factor	w _z	1,21	
Factor	n _{pl}	0,03	
Maximum relative slenderness	λ _{rel,max}	2,26	
Factor	C _{yy}	0,95	
Factor	C _{yz}	0,84	
Factor	C _{zy}	0,85	
Factor	C _{zz}	0,95	

Unity check (6.61) = 0,17 + 0,56 + 0,02 = 0,76 -

Unity check (6.62) = 0,04 + 0,44 + 0,03 = 0,52 -

The member satisfies the stability check.

7.5. Veliki stup – Pozicija 9

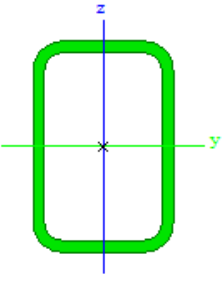
Name	veliki stup	
Type	CFRHS180X120X10	
Source description	Rautaruukki Oyj / Structural Hollow Sections EN10219 / Ed.2007	
Item material	S 355	
Fabrication	rolled	
Flexural buckling y-y	a	
Flexural buckling z-z	a	
Lateral torsional buckling	Default	
Use 2D FEM analysis	x	
		
A [m ²]	5,2570e-03	
A _{y, z} [m ²]	2,1001e-03	3,1502e-03
I _{y, z} [m ⁴]	2,1488e-05	1,1408e-05
I _w [m ⁶], I _t [m ⁴]	5,8320e-08	2,5816e-05
W _{el} y, z [m ³]	2,3876e-04	1,9013e-04
W _{pl} y, z [m ³]	3,0151e-04	2,2782e-04
d _{y, z} [mm]	0	0
c _{YUCS, ZUCS} [mm]	60	90
α [deg]	0,00	
A _{L, D} [m ² /m]	5,5700e-01	1,0510e+00
M _{pl} +, - [Nm]	1,07e+05	1,07e+05
M _{pz} +, - [Nm]	8,08e+04	8,08e+04

Slika 7.5.1. Karakteristike poprečnog presjeka velikog stupa

EC-EN 1993 Steel check ULS
 Values: UC Overall
 Linear calculation
 Combination: ULS-Set B (auto)
 Coordinate system: Principal
 Extreme 1D: Cross-section
 Selection: All
 Filter: Cross-section = veliki stup -
 CFRHS180X120X10

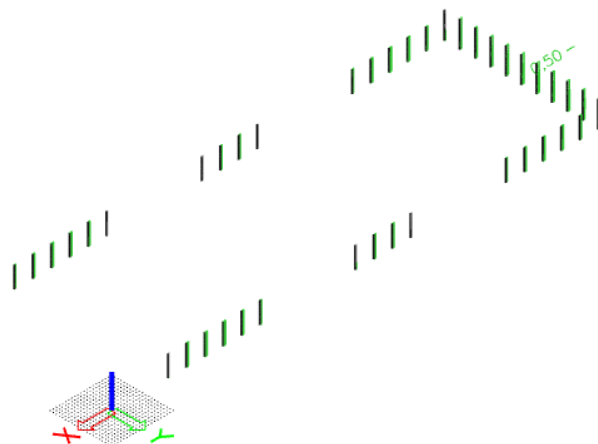

Slika 7.5.2. Prikaz iskoristivosti velikog stupa

1D internal forces

Values: M_x
Linear calculation
Combination: ULS-Set B (auto)
Coordinate system: Principal
Extreme 1D: Global
Selection: All
Filter: Cross-section = veliki stup -
CFRHS180X120X10

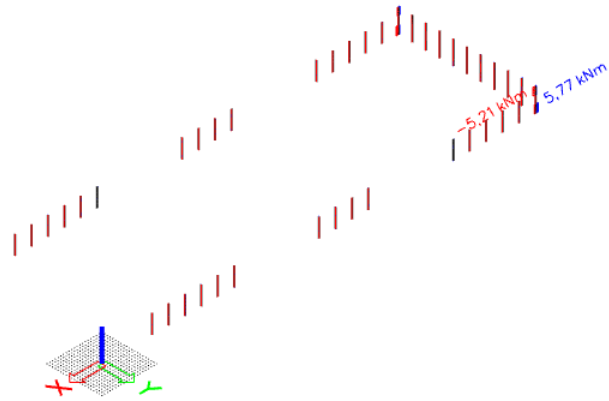

Slika 7.5.3.Moment M_x

1D internal forces

Values: M_y
Linear calculation
Combination: ULS-Set B (auto)
Coordinate system: Principal
Extreme 1D: Global
Selection: All
Filter: Cross-section = veliki stup -
CFRHS180X120X10

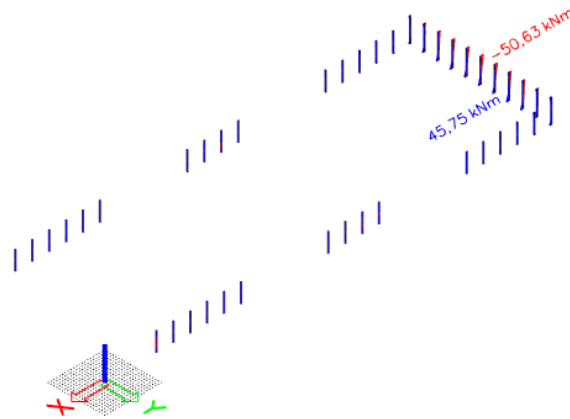

Slika 7.5.4.Moment M_y

1D internal forces

Values: M_z
Linear calculation
Combination: ULS-Set B (auto)
Coordinate system: Principal
Extreme 1D: Global
Selection: All
Filter: Cross-section = veliki stup -
CFRHS180X120X10

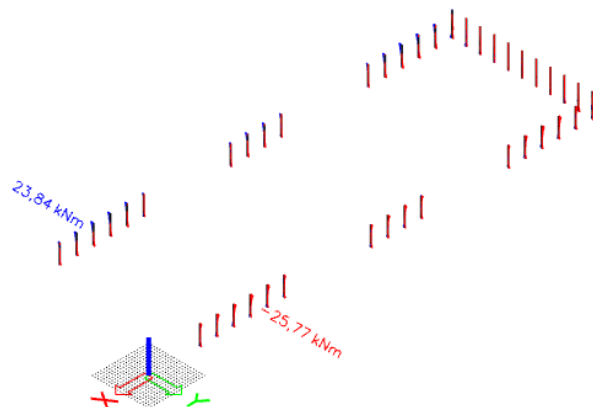

Slika 7.5.5.Moment M_z

1D internal forces
 Values: V_y
 Linear calculation
 Combination: ULS-Set B (auto)
 Coordinate system: Principal
 Extreme 1D: Global
 Selection: All
 Filter: Cross-section = veliki stup -
 CFRHS180X120X10

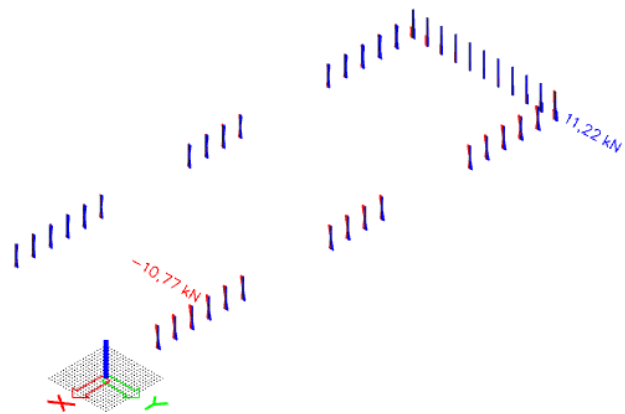

Slika 7.5.6. Poprečna sila V_y

1D internal forces
 Values: V_z
 Linear calculation
 Combination: ULS-Set B (auto)
 Coordinate system: Principal
 Extreme 1D: Global
 Selection: All
 Filter: Cross-section = veliki stup -
 CFRHS180X120X10

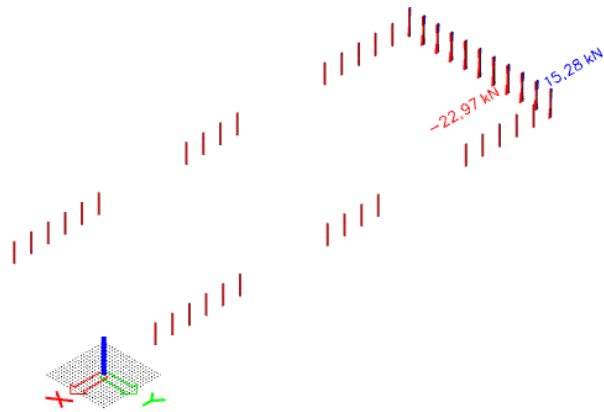

Slika 7.5.7. Poprečna sila V_z

1D internal forces
 Values: N
 Linear calculation
 Combination: ULS-Set B (auto)
 Coordinate system: Principal
 Extreme 1D: Global
 Selection: All
 Filter: Cross-section = veliki stup -
 CFRHS180X120X10

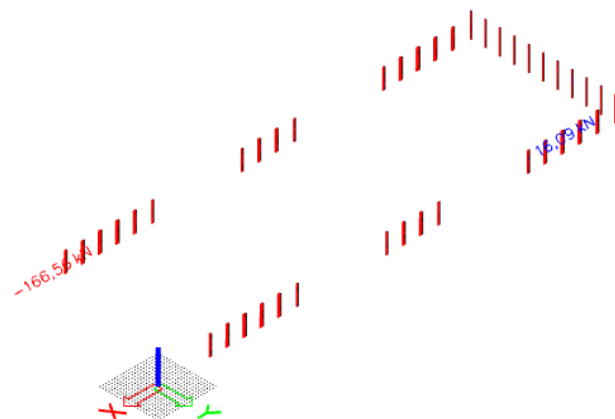

Slika 7.5.8. Uzdužna sila N

7.6. Mali stup – Pozicija 10

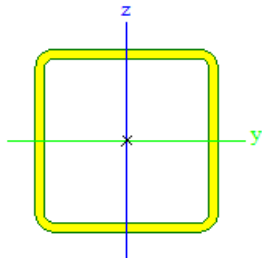
Name	mali stup	
Type	CFRHS120X120X6	
Source description	Rautaruukki Oyj / Structural Hollow Sections EN10219 / Ed.2007	
Item material	S 355	
Fabrication	rolled	
Flexural buckling y-y	a	
Flexural buckling z-z	a	
Lateral torsional buckling	Default	
Use 2D FEM analysis	x	
		
A [m ²]	2,6430e-03	
A _{y, z} [m ²]	1,3208e-03	1,3208e-03
I _{y, z} [m ⁴]	5,6216e-06	5,6216e-06
I _w [m ⁶], t [m ⁴]	1,2442e-08	9,1346e-06
W _{el, y, z} [m ³]	9,3690e-05	9,3690e-05
W _{pl, y, z} [m ³]	1,1161e-04	1,1161e-04
d _{y, z} [mm]	0	0
c _{YUCS, ZUCS} [mm]	60	60
α [deg]	0,00	
A _{L, D} [m ² /m]	4,5900e-01	8,8095e-01
M _{pl, y, z} [Nm]	3,96e+04	3,96e+04
M _{pl, z, y} [Nm]	3,96e+04	3,96e+04

Slika 7.6.1. Karakteristike poprečnog presjeka malog stupa

EC-EN 1993 Steel check ULS

Values: UC Overall
 Linear calculation
 Combination: ULS-Set B (auto)
 Coordinate system: Principal
 Extreme 1D: Cross-section
 Selection: All
 Filter: Cross-section = mali stup -
 CFRHS120X120X6

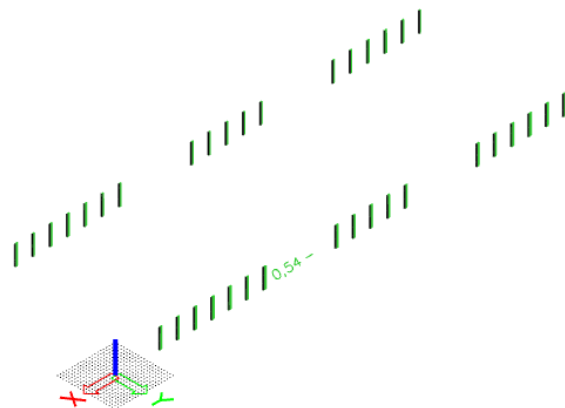

Slika 7.6.2. Prikaz iskoristivosti malog stupa

1D internal forces

Values: M_x
Linear calculation
Combination: ULS-Set B (auto)
Coordinate system: Principal
Extreme 1D: Global
Selection: All
Filter: Cross-section = mali stup -
CFRHS120X120X6

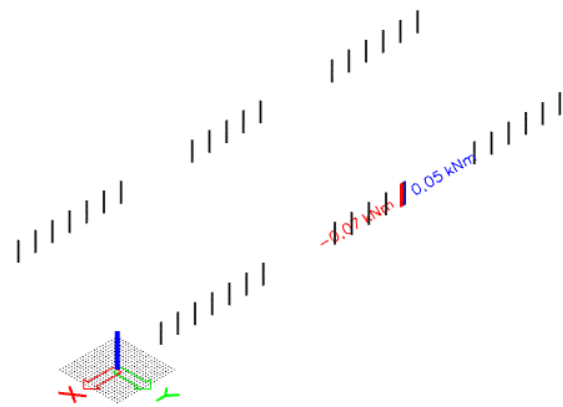

Slika 7.6.3. Moment M_x

1D internal forces

Values: M_y
Linear calculation
Combination: ULS-Set B (auto)
Coordinate system: Principal
Extreme 1D: Global
Selection: All
Filter: Cross-section = mali stup -
CFRHS120X120X6

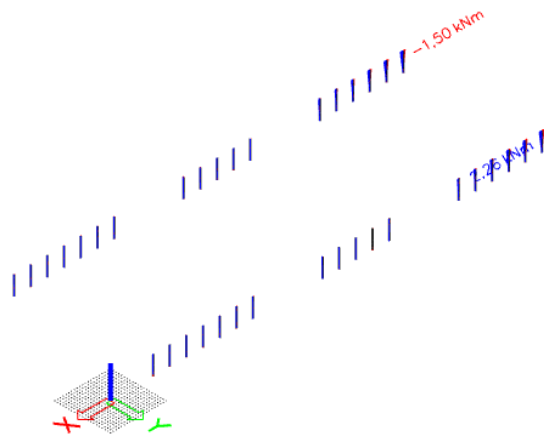

Slika 7.6.4. Moment M_y

1D internal forces

Values: M_z
Linear calculation
Combination: ULS-Set B (auto)
Coordinate system: Principal
Extreme 1D: Global
Selection: All
Filter: Cross-section = mali stup -
CFRHS120X120X6

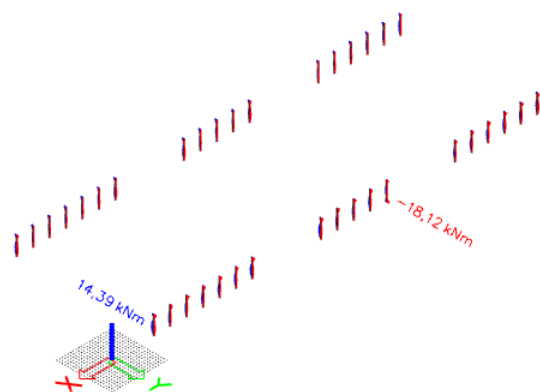

Slika 7.6.5. Moment M_z

1D internal forces

Values: V_y
Linear calculation
Combination: ULS-Set B (auto)
Coordinate system: Principal
Extreme 1D: Global
Selection: All
Filter: Cross-section = mali stup -
CFRHS120X120X6

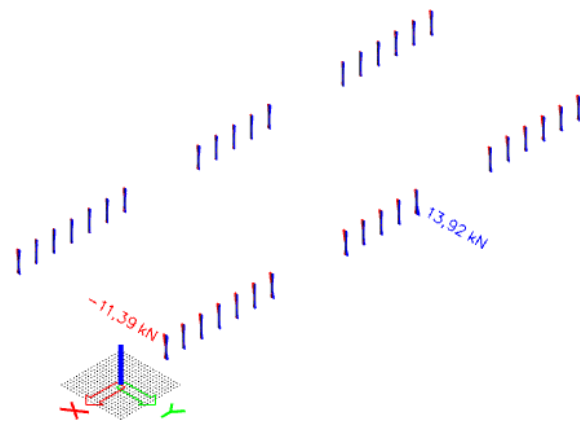

Slika 7.6.6. Poprečna sila V_y

1D internal forces

Values: V_z
Linear calculation
Combination: ULS-Set B (auto)
Coordinate system: Principal
Extreme 1D: Global
Selection: All
Filter: Cross-section = mali stup -
CFRHS120X120X6

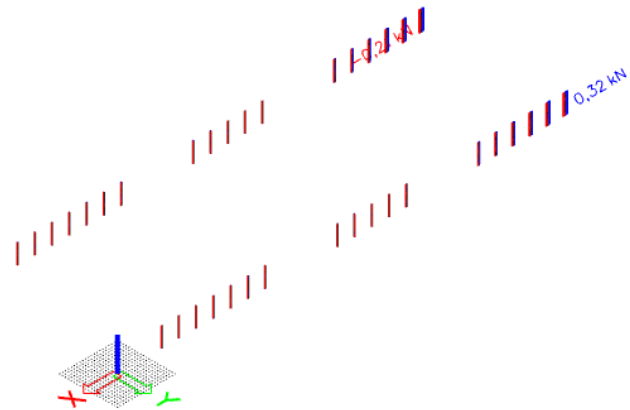

Slika 7.6.7. Poprečna sila V_z

1D internal forces

Values: N
Linear calculation
Combination: ULS-Set B (auto)
Coordinate system: Principal
Extreme 1D: Global
Selection: All
Filter: Cross-section = mali stup -
CFRHS120X120X6

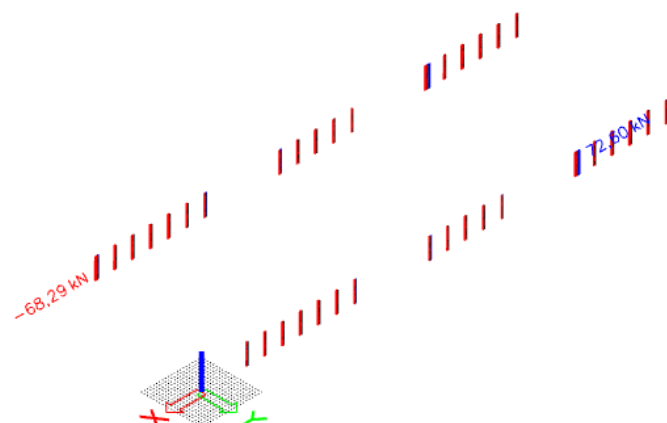

Slika 7.6.8. Uzdužna sila N

EC-EN 1993 Steel check ULS

Linear calculation
 Combination: ULS-Set B (auto)
 Coordinate system: Principal
 Extreme 1D: Cross-section
 Selection: All
 Filter: Cross-section = mali stup - CFRHS120X120X6

EN 1993-1-1 Code Check

National annex: Standard EN

Member B489 | **0,000 / 7,000 m** | **CFRHS120X120X6** | **S 355** | **ULS-Set B (auto)** | **0,54 -**

Combination key

ULS-Set B (auto) / 1.35*LC1 + 1.50*korisno +
 1.35*dodatno stalno + 0.90*3DWind14 +
 1.50*temperatura +

Partial safety factors

γ_{M0} for resistance of cross-sections	1,00
γ_{M1} for resistance to instability	1,00
γ_{M2} for resistance of net sections	1,25

Material

Yield strength	f_y	355,0	MPa
Ultimate strength	f_u	490,0	MPa
Fabrication		Rolled	

.....SECTION CHECK:.....

The critical check is on position 0,000 m

Internal forces		Calculated	Unit
Normal force	N_{Ed}	-28,24	kN
Shear force	$V_{y,Ed}$	9,87	kN
Shear force	$V_{z,Ed}$	0,03	kN
Torsion	T_{Ed}	0,00	kNm
Bending moment	$M_{y,Ed}$	0,00	kNm
Bending moment	$M_{z,Ed}$	0,00	kNm

Classification for cross-section design

Classification according to EN 1993-1-1 article 5.5.2

Classification of Internal and Outstand parts according to EN 1993-1-1 Table 5.2 Sheet 1 & 2

Id	Type	c [mm]	t [mm]	σ_1 [kN/m ²]	σ_2 [kN/m ²]	ψ [-]	k_{σ} [-]	α [-]	c/t [-]	Class 1 Limit [-]	Class 2 Limit [-]	Class 3 Limit [-]	Class
1	I	102	6	1,069e+04	1,069e+04	1,00		1,00	17,00	22,78	27,66	30,92	1
3	I	102	6	1,069e+04	1,069e+04	1,00		1,00	17,00	22,78	27,66	30,92	1
5	I	102	6	1,069e+04	1,069e+04	1,00		1,00	17,00	22,78	27,66	30,92	1
7	I	102	6	1,069e+04	1,069e+04	1,00		1,00	17,00	22,78	27,66	30,92	1

Note: The Classification limits have been set according to Semi-Comp+.
 The cross-section is classified as Class 1

Compression check

According to EN 1993-1-1 article 6.2.4 and formula (6.9)

Cross-section area	A	2,6430e-03	m ²
Compression resistance	$N_{c,Rd}$	938,26	kN
Unity check		0,03	-

Shear check for V_y

According to EN 1993-1-1 article 6.2.6 and formula (6.17)

Shear correction factor	η	1,20	
Shear area	A_v	1,3215e-03	m ²
Plastic shear resistance for V_y	$V_{pl,y,Rd}$	270,85	kN
Unity check		0,04	-

Shear check for V_z

According to EN 1993-1-1 article 6.2.6 and formula (6.17)

Shear correction factor	η	1,20	
Shear area	A_v	1,3215e-03	m ²
Plastic shear resistance for V_z	$V_{pl,z,Rd}$	270,85	kN
Unity check		0,00	-

The member satisfies the section check.

.....STABILITY CHECK:.....

Classification for member buckling design

Decisive position for stability classification: 7,000 m

Classification according to EN 1993-1-1 article 5.5.2

Classification of Internal and Outstand parts according to EN 1993-1-1 Table 5.2 Sheet 1 & 2

Id	Type	c [mm]	t [mm]	σ_1 [kN/m ²]	σ_2 [kN/m ²]	Ψ [-]	k_{σ} [-]	α [-]	c/t [-]	Class 1 Limit [-]	Class 2 Limit [-]	Class 3 Limit [-]	Class
1	I	102	5	1,691e+05	-1,540e+05	-0,91		0,52	17,00	54,58	63,28	91,76	1
3	I	102	5	-1,723e+05	-1,685e+05								
5	I	102	6	-1,492e+05	1,739e+05	-0,86		0,54	17,00	52,29	60,82	87,00	1
7	I	102	6	1,927e+05	1,884e+05	0,98		1,00	17,00	22,78	27,66	31,16	1

Note: The Classification limits have been set according to Semi-Comp+.
The cross-section is classified as Class 1

Flexural Buckling check

According to EN 1993-1-1 article 6.3.1.1 and formula (6.46)

Buckling parameters		yy	zz	
Sway type		sway	non-sway	
System length	L	7,000	7,000	m
Buckling factor	k	0,43	0,78	
Buckling length	l_{cr}	3,000	5,443	m
Critical Euler load	N_{cr}	1294,60	393,34	kN
Slenderness	λ	65,05	118,01	
Relative slenderness	λ_{rel}	0,85	1,54	
Limit slenderness	$\lambda_{rel,0}$	0,20	0,20	
Buckling curve	a	a		
Imperfection	α	0,21	0,21	
Reduction factor	χ	0,77	0,35	
Buckling resistance	$N_{b,Rd}$	717,86	332,41	kN

Flexural Buckling verification			
Cross-section area	A	2,6430e-03	m ²
Buckling resistance	$N_{b,Rd}$	332,41	kN
Unity check		0,08	-

Torsional(-Flexural) Buckling check

According to EN 1993-1-1 article 6.3.1.1 and formula (6.46)

Note: The cross-section concerns a RHS section which is not susceptible to Torsional(-Flexural) Buckling.

Bending and axial compression check

According to EN 1993-1-1 article 6.3.3 and formula (6.61),(6.62)

Bending and axial compression check parameters			
Interaction method		alternative method 1	
Cross-section area	A	2,6430e-03	m ²
Plastic section modulus	$W_{pl,y}$	1,1161e-04	m ³
Plastic section modulus	$W_{pl,z}$	1,1161e-04	m ³
Design compression force	N_{Ed}	28,24	kN
Design bending moment (maximum)	$M_{y,Ed}$	0,24	kNm
Design bending moment (maximum)	$M_{z,Ed}$	-17,81	kNm
Characteristic compression resistance	N_{Rk}	938,26	kN
Characteristic moment resistance	$M_{y,Rk}$	39,62	kNm
Characteristic moment resistance	$M_{z,Rk}$	39,62	kNm
Reduction factor	χ_y	0,77	
Reduction factor	χ_z	0,35	
Reduction factor	χ_{LT}	1,00	
Interaction factor	k_{yy}	0,81	
Interaction factor	k_{yz}	0,67	
Interaction factor	k_{zy}	0,48	
Interaction factor	k_{zz}	1,01	

Maximum moment $M_{y,Ed}$ is derived from beam B489 position 7,000 m.

Maximum moment $M_{z,Ed}$ is derived from beam B489 position 7,000 m.

Interaction method 1 parameters			
Critical Euler load	$N_{cr,y}$	1294,60	kN
Critical Euler load	$N_{cr,z}$	393,34	kN
Elastic critical load	$N_{cr,T}$	173561,09	kN
Plastic section modulus	$W_{pl,y}$	1,1161e-04	m ³
Elastic section modulus	$W_{el,y}$	9,3690e-05	m ³
Plastic section modulus	$W_{pl,z}$	1,1161e-04	m ³
Elastic section modulus	$W_{el,z}$	9,3690e-05	m ³
Second moment of area	I_y	5,6216e-06	m ⁴
Second moment of area	I_z	5,6216e-06	m ⁴
Torsional constant	I_t	9,1346e-06	m ⁴
Method for equivalent moment factor $C_{my,0}$		Table A.2 Line 1 (Linear)	
Ratio of end moments	ψ_y	0,00	
Equivalent moment factor	$C_{my,0}$	0,79	
Method for equivalent moment factor $C_{mz,0}$		Table A.2 Line 2 (General)	

Interaction method 1 parameters			
Design bending moment (maximum)	$M_{z,Ed}$	-17,81	kNm
Maximum relative deflection	δ_y	-42,5	mm
Equivalent moment factor	$C_{mz,0}$	0,97	
Factor	μ_y	0,99	
Factor	μ_z	0,95	
Factor	ϵ_y	0,24	
Factor	a_{LT}	0,00	
Critical moment for uniform bending	$M_{cr,0}$	419,00	kNm
Relative slenderness	$\lambda_{rel,0}$	0,31	
Limit relative slenderness	$\lambda_{rel,0,lim}$	0,26	
Equivalent moment factor	C_{my}	0,79	
Equivalent moment factor	C_{mz}	0,97	
Equivalent moment factor	C_{mLT}	1,00	
Factor	b_{LT}	0,00	
Factor	c_{LT}	0,00	
Factor	d_{LT}	0,00	
Factor	e_{LT}	0,00	
Factor	w_y	1,19	
Factor	w_z	1,19	
Factor	η_{pl}	0,03	
Maximum relative slenderness	$\lambda_{rel,max}$	1,54	
Factor	C_{yy}	0,99	
Factor	C_{yz}	0,94	
Factor	C_{zy}	0,96	
Factor	C_{zz}	0,98	

Unity check (6.61) = $0,04 + 0,00 + 0,30 = 0,34$ -

Unity check (6.62) = $0,08 + 0,00 + 0,45 = 0,54$ -

The member satisfies the stability check.

Student version

Student version

7.7. Unutarnje grede – Pozicija 11

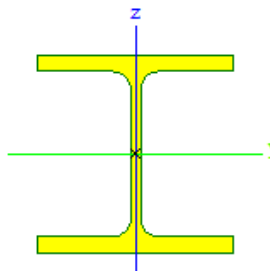
Name	grede unutra	
Type	HEB160	
Source description	Profil Arbed / Structural shapes / Edition Octobre 1995	
Item material	S 355	
Fabrication	rolled	
Flexural buckling y-y	b	
Flexural buckling z-z	c	
Lateral torsional buckling	Default	
Use 2D FEM analysis	*	
		
A [m ²]	5,4250e-03	
A _{y, z} [m ²]	4,0302e-03	1,3724e-03
I _{y, z} [m ⁴]	2,4920e-05	8,8920e-06
I _w [m ⁶], t [m ⁴]	4,7943e-08	3,1240e-07
W _{el, y, z} [m ³]	3,1150e-04	1,1120e-04
W _{pl, y, z} [m ³]	3,5400e-04	1,7000e-04
d _{y, z} [mm]	0	0
c _{YUCS, ZUCS} [mm]	80	80
α [deg]	0,00	
A _{L, D} [m ² /m]	9,1800e-01	9,1813e-01
M _{py} +, - [Nm]	1,26e+05	1,26e+05
M _{pz} +, - [Nm]	6,03e+04	6,03e+04

Slika 7.7.1. Karakteristike poprečnog presjeka unutarnjih greda

EC-EN 1993 Steel check ULS

Values: UC Overall

Linear calculation

Combination: ULS-Set B (auto)

Coordinate system: Principal

Extreme 1D: Cross-section

Selection: All

Filter: Cross-section = grede unutra -

HEB160

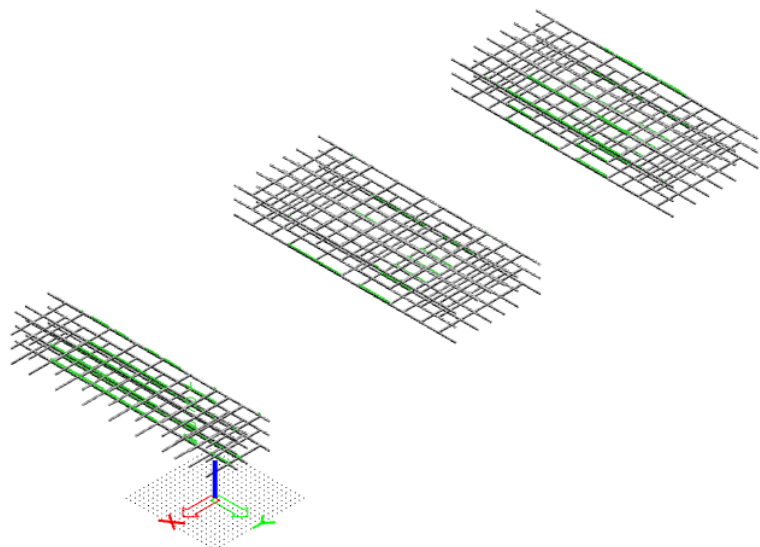

Slika 7.7.2. Prikaz iskoristivosti unutarnjih greda

1D internal forces

Values: M_x
Linear calculation
Combination: ULS-Set B (auto)
Coordinate system: Principal
Extreme 1D: Global
Selection: All
Filter: Cross-section = grede unutra -
HEB160

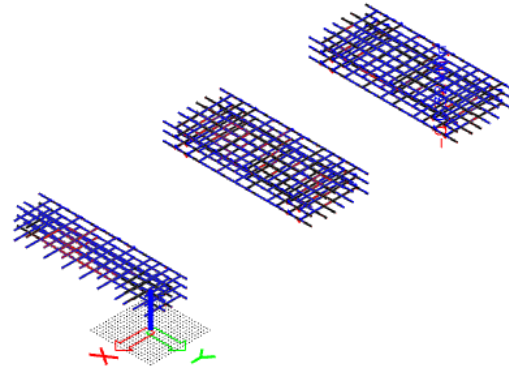

Slika 7.7.3. Moment M_x

1D internal forces

Values: M_y
Linear calculation
Combination: ULS-Set B (auto)
Coordinate system: Principal
Extreme 1D: Global
Selection: All
Filter: Cross-section = grede unutra -
HEB160

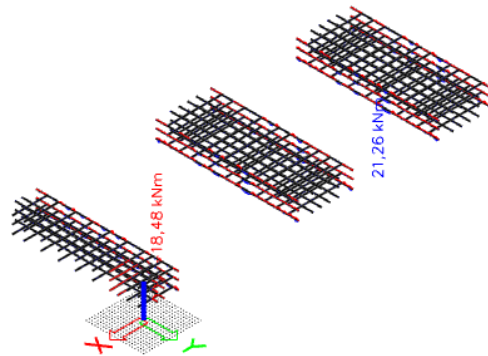

Slika 7.7.4. Moment M_y

1D internal forces

Values: M_z
Linear calculation
Combination: ULS-Set B (auto)
Coordinate system: Principal
Extreme 1D: Global
Selection: All
Filter: Cross-section = grede unutra -
HEB160

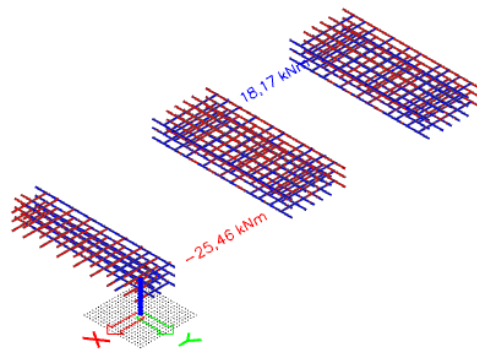

Slika 7.7.5. Moment M_z

1D internal forces

Values: V_y
Linear calculation
Combination: ULS-Set B (auto)
Coordinate system: Principal
Extreme 1D: Global
Selection: All
Filter: Cross-section = grede unutra -
HEB160

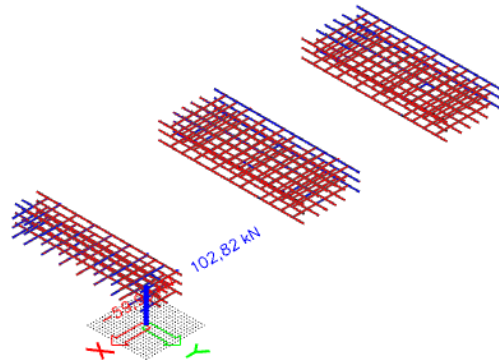

Slika 7.7.6. Poprečna sila V_y

1D internal forces

Values: V_z
Linear calculation
Combination: ULS-Set B (auto)
Coordinate system: Principal
Extreme 1D: Global
Selection: All
Filter: Cross-section = grede unutra -
HEB160

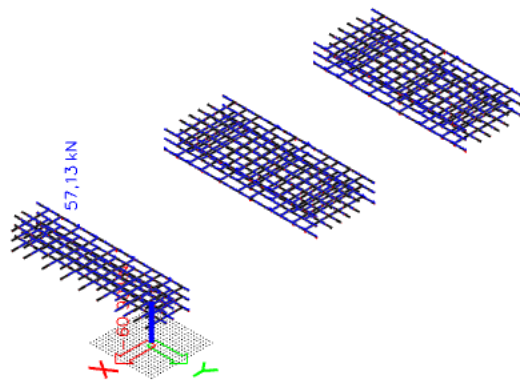

Slika 7.7.7. Poprečna sila V_z

1D internal forces

Values: N
Linear calculation
Combination: ULS-Set B (auto)
Coordinate system: Principal
Extreme 1D: Global
Selection: All
Filter: Cross-section = grede unutra -
HEB160

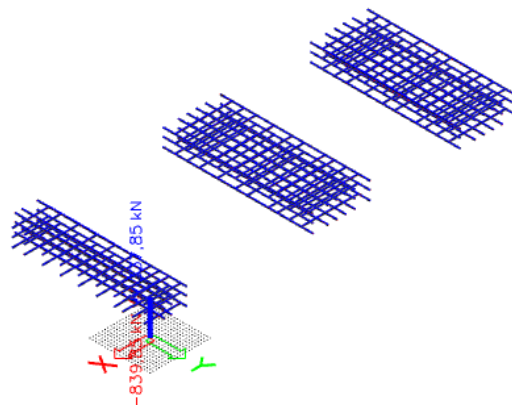

Slika 7.7.8. Uzdužna sila N

EC-EN 1993 Steel check ULS

Linear calculation
 Combination: ULS-Set B (auto)
 Coordinate system: Principal
 Extreme 1D: Cross-section
 Selection: All
 Filter: Cross-section = grede unutra - HEB160

EN 1993-1-1 Code Check

National annex: Standard EN

Member B2530	0,000 / 2,800 m	HEB160	S 355	ULS-Set B (auto)	0,70 -
--------------	-----------------	--------	-------	------------------	--------

Combination key

ULS-Set B (auto) / LC1 + 1.50*snijeg + dodatno stalno + 0.90*3DWind11 + 1.50*temperatura -

Partial safety factors

γ_{M0} for resistance of cross-sections	1,00
γ_{M1} for resistance to instability	1,00
γ_{M2} for resistance of net sections	1,25

Material

Yield strength	f_y	355,0	MPa
Ultimate strength	f_u	490,0	MPa
Fabrication		Rolled	

....SECTION CHECK:...

The critical check is on position 0,000 m

Internal forces		Calculated	Unit
Normal force	N_{Ed}	1337,85	kN
Shear force	$V_{y,Ed}$	0,81	kN
Shear force	$V_{z,Ed}$	0,58	kN
Torsion	T_{Ed}	0,00	kNm
Bending moment	$M_{y,Ed}$	0,00	kNm
Bending moment	$M_{z,Ed}$	-1,06	kNm

Classification for cross-section design

Classification according to EN 1993-1-1 article 5.5.2

Classification of Internal and Outstand parts according to EN 1993-1-1 Table 5.2 Sheet 1 & 2

Id	Type	c [mm]	t [mm]	σ_1 [kN/m ²]	σ_2 [kN/m ²]	ψ [-]	k_{σ} [-]	α [-]	c/t [-]	Class 1 Limit [-]	Class 2 Limit [-]	Class 3 Limit [-]	Class
1	SO	61	13	-2,443e+05	-2,370e+05								
3	SO	61	13	-2,488e+05	-2,561e+05								
4	I	104	8	-2,466e+05	-2,466e+05								
5	SO	61	13	-2,488e+05	-2,561e+05								
7	SO	61	13	-2,443e+05	-2,370e+05								

Note: The Classification limits have been set according to Semi-Comp+.
 The cross-section is classified as Class 1

Tension check

According to EN 1993-1-1 article 6.2.3 and formula (6.5)

Cross-section area	A	5,4250e-03	m ²
Plastic tension resistance	$N_{pl,Rd}$	1925,88	kN
Ultimate tension resistance	$N_{u,Rd}$	1913,94	kN
Tension resistance	$N_{t,Rd}$	1913,94	kN
Unity check		0,70	-

Bending moment check for M_z

According to EN 1993-1-1 article 6.2.5 and formula (6.12),(6.13)

Plastic section modulus	$W_{pl,z}$	1,7000e-04	m ³
Plastic bending moment	$M_{pl,z,Rd}$	60,35	kNm
Unity check		0,02	-

Shear check for V_y

According to EN 1993-1-1 article 6.2.6 and formula (6.17)

Shear correction factor	η	1,20	
Shear area	A_v	4,3440e-03	m ²
Plastic shear resistance for V_y	$V_{pl,y,Rd}$	890,34	kN
Unity check		0,00	-

Shear check for V_z

According to EN 1993-1-1 article 6.2.6 and formula (6.17)

Shear correction factor	η	1,20	
Shear area	A_v	1,7590e-03	m ²
Plastic shear resistance for V_z	$V_{pl,z,Rd}$	360,52	kN
Unity check		0,00	-

Torsion check

According to EN 1993-1-1 article 6.2.7 and formula (6.23)

Index of fibre	Fibre	2	
Total torsional moment	T_{Ed}	0,0	MPa
Elastic shear resistance	T_{Rd}	205,0	MPa
Unity check		0,00	-

Note: The unity check for torsion is lower than the limit value of 0,05. Therefore torsion is considered as insignificant and is ignored in the combined checks.

Combined bending, axial force and shear force check

According to EN 1993-1-1 article 6.2.9.1 and formula (6.31)

Design plastic moment resistance reduced due to N_{Ed}	$M_{N,z,Rd}$	38,49	kNm
Unity check		0,03	-

Note: Since the shear forces are less than half the plastic shear resistances their effect on the moment resistances is neglected.

The member satisfies the section check.

....:STABILITY CHECK:....

Classification for member buckling design

Decisive position for stability classification: 0,000 m

Classification according to EN 1993-1-1 article 5.5.2

Classification of Internal and Outstand parts according to EN 1993-1-1 Table 5.2 Sheet 1 & 2

Id	Type	c [mm]	t [mm]	σ_1 [kN/m ²]	σ_2 [kN/m ²]	Ψ [-]	k_σ [-]	α [-]	c/t [-]	Class 1 Limit [-]	Class 2 Limit [-]	Class 3 Limit [-]	Class
1	SO	61	13	-2,443e+05	-2,370e+05								
3	SO	61	13	-2,488e+05	-2,561e+05								
4	I	104	8	-2,466e+05	-2,466e+05								
5	SO	61	13	-2,488e+05	-2,561e+05								
7	SO	61	13	-2,443e+05	-2,370e+05								

Note: The Classification limits have been set according to Semi-Comp+.

The cross-section is classified as Class 1

Shear Buckling check

According to EN 1993-1-5 article 5 & 7.1 and formula (5.10) & (7.1)

Shear Buckling parameters			
Buckling field length	a	2,800	m
Web		unstiffened	
Web height	h_w	134	mm
Web thickness	t	8	mm
Material coefficient	ϵ	0,81	
Shear correction factor	η	1,20	

Shear Buckling verification		
Web slenderness	h_w/t	16,75
Web slenderness limit		48,82

Note: The web slenderness is such that Shear Buckling effects may be ignored according to EN 1993-1-5 article 5.1(2).

The member satisfies the stability check.

Student version

7.8. Unutarnji stup – Pozicija 12

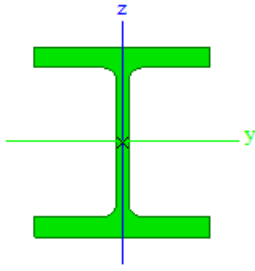
Name	stup unutra	
Type	HEM280	
Source description	Profil Arbed / Structural shapes / Edition Octobre 1995	
Item material	S 355	
Fabrication	rolled	
Flexural buckling y-y	b	
Flexural buckling z-z	c	
Lateral torsional buckling	Default	
Use 2D FEM analysis	x	
		
A [m ²]	2,4020e-02	
A _{y, z} [m ²]	1,8550e-02	6,0897e-03
I _{y, z} [m ⁴]	3,9600e-04	1,3200e-04
I _w [m ⁶], t [m ⁴]	2,5202e-06	8,0730e-06
W _{el} y, z [m ³]	2,5510e-03	9,1410e-04
W _{pl} y, z [m ³]	2,9660e-03	1,3970e-03
d y, z [mm]	0	0
c YUCS, ZUCS [mm]	144	155
α [deg]	0,00	
A _{L, D} [m ² /m]	1,6900e+00	1,6936e+00
M _{py} +, - [Nm]	1,05e+06	1,05e+06
M _{pz} +, - [Nm]	4,96e+05	4,96e+05

Slika 7.8.1. Karakteristike poprečnog presjeka unutarnjeg stupa

EC-EN 1993 Steel check ULS
 Values: UC_{Overall}
 Linear calculation
 Combination: ULS-Set B (auto)
 Coordinate system: Principal
 Extreme 1D: Cross-section
 Selection: All
 Filter: Cross-section = stup unutra -
 HEM280

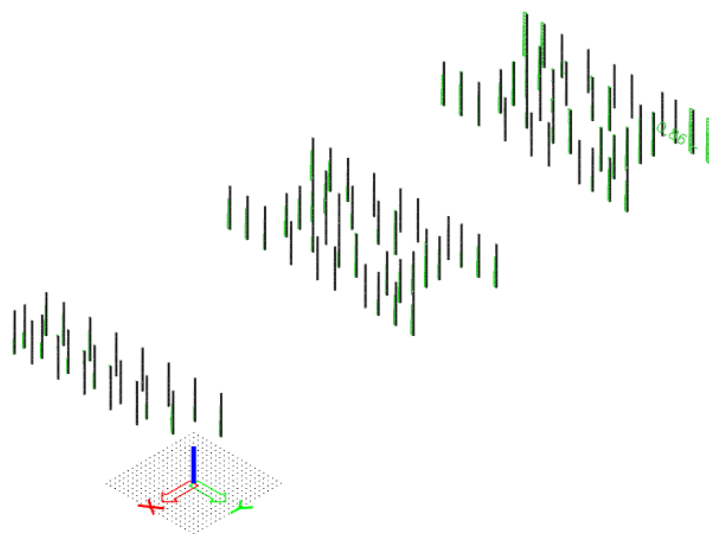

Slika 7.8.2. Prikaz iskoristivosti unutarnjih stupova

1D internal forces

Values: M_x
Linear calculation
Combination: ULS-Set B (auto)
Coordinate system: Principal
Extreme 1D: Global
Selection: All
Filter: Cross-section = stup unutra -
HEM280

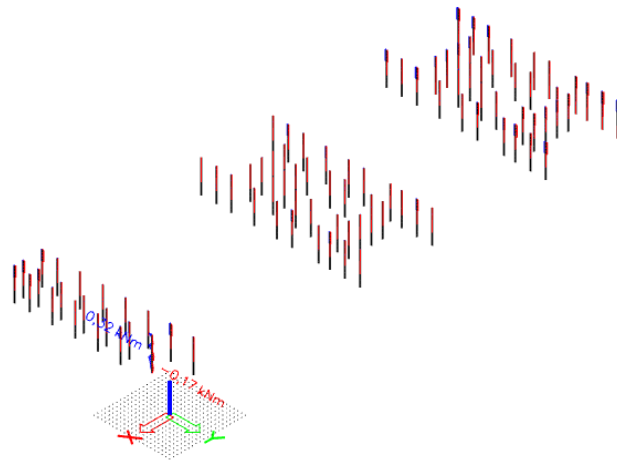

Slika 7.8.3.Moment M_x

1D internal forces

Values: M_y
Linear calculation
Combination: ULS-Set B (auto)
Coordinate system: Principal
Extreme 1D: Global
Selection: All
Filter: Cross-section = stup unutra -
HEM280

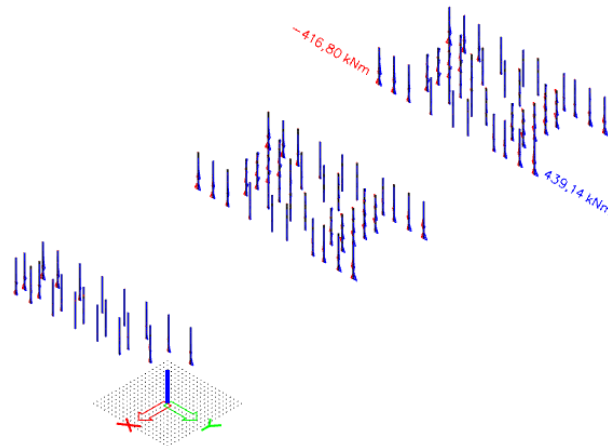

Slika 7.8.4.Moment M_y

1D internal forces

Values: M_z
Linear calculation
Combination: ULS-Set B (auto)
Coordinate system: Principal
Extreme 1D: Global
Selection: All
Filter: Cross-section = stup unutra -
HEM280

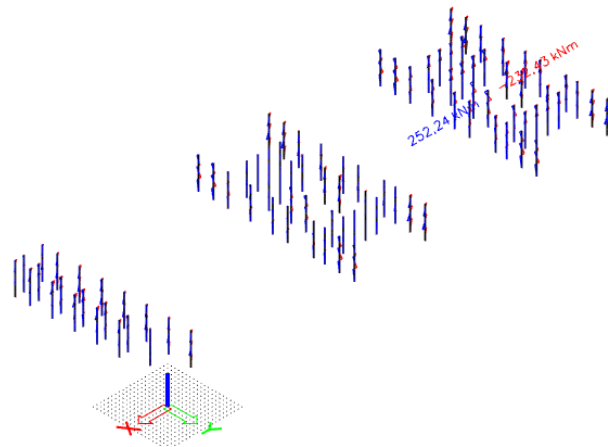

Slika 7.8.5.Moment M_z

1D internal forces

Values: V_y
Linear calculation
Combination: ULS-Set B (auto)
Coordinate system: Principal
Extreme 1D: Global
Selection: All
Filter: Cross-section = stup unutra -
HEM280

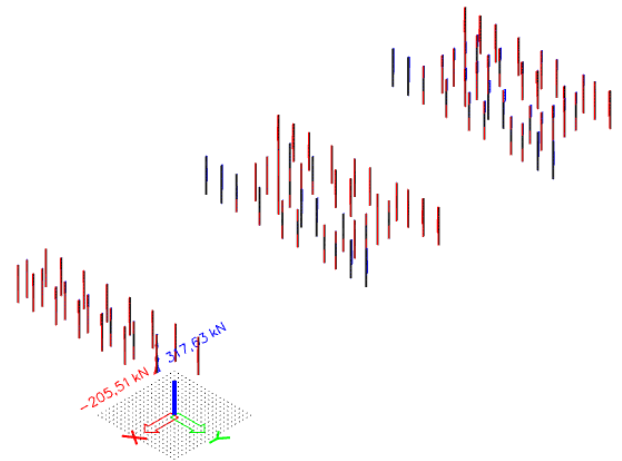

Slika 7.8.6. Poprečna sila V_y

1D internal forces

Values: V_z
Linear calculation
Combination: ULS-Set B (auto)
Coordinate system: Principal
Extreme 1D: Global
Selection: All
Filter: Cross-section = stup unutra -
HEM280

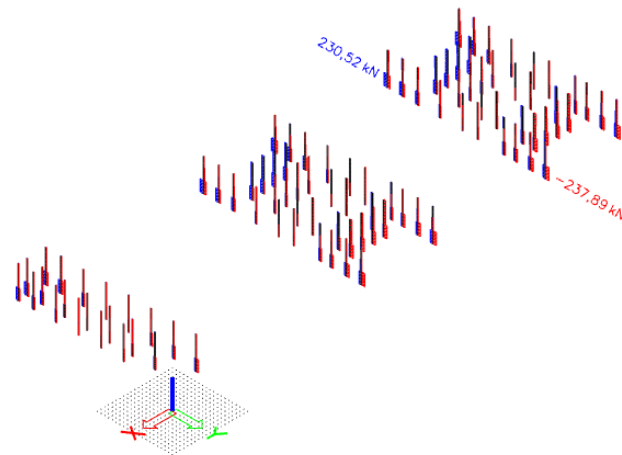

Slika 7.8.7. Poprečna sila V_z

1D internal forces

Values: N
Linear calculation
Combination: ULS-Set B (auto)
Coordinate system: Principal
Extreme 1D: Global
Selection: All
Filter: Cross-section = stup unutra -
HEM280

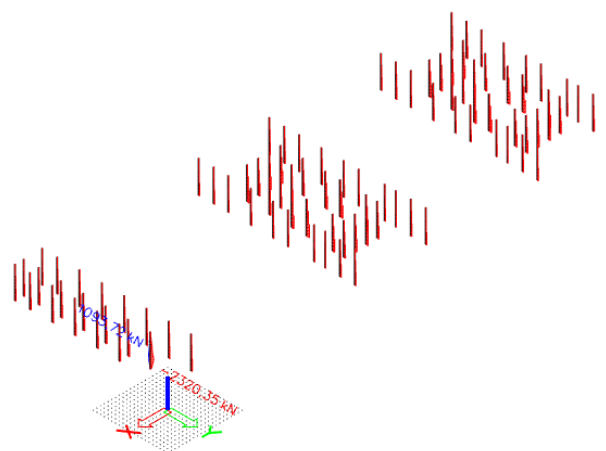

Slika 7.8.8. Uzdužna sila N

EC-EN 1993 Steel check ULS

Linear calculation
 Combination: ULS-Set B (auto)
 Coordinate system: Principal
 Extreme 1D: Cross-section
 Selection: All
 Filter: Cross-section = stup unutra - HEM280

EN 1993-1-1 Code Check

National annex: Standard EN

Member B5410	0,000 / 3,000 m	HEM280	S 355	ULS-Set B (auto)	0,86 -
---------------------	------------------------	---------------	--------------	-------------------------	---------------

Combination key

ULS-Set B (auto) / 1.35*LC1 + 1.50*korisno + 1.50*snijeg
 + 1.35*dodatno stalno + 0.90*3DWind14 +
 1.50*temperatura -

Partial safety factors

γ_{M0} for resistance of cross-sections	1,00
γ_{M1} for resistance to instability	1,00
γ_{M2} for resistance of net sections	1,25

Material

Yield strength	f_y	355,0	MPa
Ultimate strength	f_u	490,0	MPa
Fabrication		Rolled	

....:SECTION CHECK:....

The critical check is on position 0,000 m

Internal forces		Calculated	Unit
Normal force	N_{Ed}	-681,58	kN
Shear force	$V_{y,Ed}$	-23,40	kN
Shear force	$V_{z,Ed}$	-220,83	kN
Torsion	T_{Ed}	-0,01	kNm
Bending moment	$M_{y,Ed}$	420,94	kNm
Bending moment	$M_{z,Ed}$	0,00	kNm

Classification for cross-section design

Classification according to EN 1993-1-1 article 5.5.2

Classification of Internal and Outstand parts according to EN 1993-1-1 Table 5.2 Sheet 1 & 2

Id	Type	c [mm]	t [mm]	σ_1 [kN/m ²]	σ_2 [kN/m ²]	ψ [-]	k_{σ} [-]	α [-]	c/t [-]	Class 1 Limit [-]	Class 2 Limit [-]	Class 3 Limit [-]	Class
1	SO	111	33	-1,190e+05	-1,190e+05								
3	SO	111	33	-1,190e+05	-1,190e+05								
4	I	196	19	-7,593e+04	1,327e+05	-0,57		0,76	10,59	31,98	38,30	68,04	1
5	SO	111	33	1,758e+05	1,758e+05	1,00	0,43	1,00	3,36	7,32	8,14	11,39	1
7	SO	111	33	1,758e+05	1,758e+05	1,00	0,43	1,00	3,36	7,32	8,14	11,39	1

Note: The Classification limits have been set according to Semi-Comp+.

The cross-section is classified as Class 1

Compression check

According to EN 1993-1-1 article 6.2.4 and formula (6.9)

Cross-section area	A	2,4020e-02	m ²
Compression resistance	$N_{c,Rd}$	8527,10	kN
Unity check		0,08	-

Bending moment check for M_y

According to EN 1993-1-1 article 6.2.5 and formula (6.12),(6.13)

Plastic section modulus	$W_{pl,y}$	2,9660e-03	m ³
Plastic bending moment	$M_{pl,y,Rd}$	1052,93	kNm
Unity check		0,40	-

Shear check for V_y

According to EN 1993-1-1 article 6.2.6 and formula (6.17)

Shear correction factor	η	1,20	
Shear area	A_v	1,9794e-02	m ²
Plastic shear resistance for V_y	$V_{pl,y,Rd}$	4057,02	kN
Unity check		0,01	-

Shear check for V_z

According to EN 1993-1-1 article 6.2.6 and formula (6.17)

Shear correction factor	η	1,20	
Shear area	A_v	7,2065e-03	m ²
Plastic shear resistance for V_z	$V_{pl,z,Rd}$	1477,04	kN
Unity check		0,15	-

Torsion check

According to EN 1993-1-1 article 6.2.7 and formula (6.23)

Index of fibre	Fibre	2	
Total torsional moment	T_{Ed}	0,0	MPa
Elastic shear resistance	T_{Rd}	205,0	MPa
Unity check		0,00	-

Note: The unity check for torsion is lower than the limit value of 0,05. Therefore torsion is considered as insignificant and is ignored in the combined checks.

Combined bending, axial force and shear force check

According to EN 1993-1-1 article 6.2.9.1 and formula (6.31)

Plastic bending moment	$M_{pl,y,Rd}$	1052,93	kNm
Unity check		0,40	-

Note: Since the shear forces are less than half the plastic shear resistances their effect on the moment resistances is neglected.

Note: Since the axial force satisfies both criteria (6.33) and (6.34) of EN 1993-1-1 article 6.2.9.1(4) its effect on the moment resistance about the y-y axis is neglected.

The member satisfies the section check.

....:STABILITY CHECK:....

Classification for member buckling design

Decisive position for stability classification: 3,000 m

Classification according to EN 1993-1-1 article 5.5.2

Classification of Internal and Outstand parts according to EN 1993-1-1 Table 5.2 Sheet 1 & 2

Id	Type	c [mm]	t [mm]	σ_1 [kN/m ²]	σ_2 [kN/m ²]	Ψ [-]	k_{Gr} [-]	α [-]	c/t [-]	Class 1 Limit [-]	Class 2 Limit [-]	Class 3 Limit [-]	Class
1	SO	111	33	1,304e+05	1,894e+05	0,69	0,46	1,00	3,36	7,32	8,14	11,57	1
3	SO	111	33	9,492e+04	3,587e+04	0,38	0,81	1,00	3,36	7,32	8,14	15,33	1
4	I	196	19	8,792e+04	-3,179e+04	-0,36		0,76	10,59	32,14	38,48	58,61	1
5	SO	111	33	-7,425e+04	-1,333e+05								
7	SO	111	33	-3,879e+04	2,026e+04	-1,91	1,23	0,34	3,36	21,34	23,71	18,94	1

Note: The Classification limits have been set according to Semi-Comp+.

The cross-section is classified as Class 1

Flexural Buckling check

According to EN 1993-1-1 article 6.3.1.1 and formula (6.46)

Buckling parameters		yy	zz	
Sway type		sway	non-sway	
System length	L	8,700	8,700	m
Buckling factor	k	1,26	0,76	
Buckling length	l_{cr}	10,997	6,578	m
Critical Euler load	N_{cr}	6786,27	6323,38	kN
Slenderness	λ	85,65	88,73	
Relative slenderness	λ_{rel}	1,12	1,16	
Limit slenderness	$\lambda_{rel,0}$	0,20	0,20	
Buckling curve		b	c	
Imperfection	α	0,34	0,49	
Reduction factor	χ	0,52	0,45	
Buckling resistance	$N_{b,Rd}$	4458,12	3860,02	kN

Flexural Buckling verification

Cross-section area	A	2,4020e-02	m ²
Buckling resistance	$N_{b,Rd}$	3860,02	kN
Unity check		0,18	-

Torsional(-Flexural) Buckling check

According to EN 1993-1-1 article 6.3.1.1 and formula (6.46)

Note: For this I-section the Torsional(-Flexural) buckling resistance is higher than the resistance for Flexural buckling. Therefore Torsional(-Flexural) buckling is not printed on the output.

Lateral Torsional Buckling check

According to EN 1993-1-1 article 6.3.2.1 & 6.3.2.3 and formula (6.54)

LTB parameters			
Method for LTB curve		Alternative case	
Plastic section modulus	$W_{pl,y}$	2,9660e-03	m ³
Elastic critical moment	M_{cr}	3230,18	kNm
Relative slenderness	$\lambda_{rel,LT}$	0,57	
Limit slenderness	$\lambda_{rel,LT,0}$	0,40	

Note: The slenderness or bending moment is such that Lateral Torsional Buckling effects may be ignored according to EN 1993-1-1 article 6.3.2.2(4).

Mcr parameters			
LTB length	l_{LT}	8,700	m
Influence of load position		no influence	
Correction factor	k	1,00	
Correction factor	k_{sw}	1,00	
LTB moment factor	C_1	2,00	
LTB moment factor	C_2	1,15	
LTB moment factor	C_3	0,41	
Shear centre distance	d_z	0	mm
Distance of load application	z_0	0	mm
Mono-symmetry constant	β_y	0	mm
Mono-symmetry constant	z_j	0	mm

Note: C parameters are determined according to ECSS 119 2006 / Galea 2002.

Bending and axial compression check

According to EN 1993-1-1 article 6.3.3 and formula (6.61),(6.62)

Bending and axial compression check parameters			
Interaction method		alternative method 1	
Cross-section area	A	2,4020e-02	m^2
Plastic section modulus	$W_{pl,y}$	2,9660e-03	m^3
Plastic section modulus	$W_{pl,z}$	1,3970e-03	m^3
Design compression force	N_{Ed}	681,58	kN
Design bending moment (maximum)	$M_{y,Ed}$	420,94	kNm
Design bending moment (maximum)	$M_{z,Ed}$	176,24	kNm
Characteristic compression resistance	N_{Rk}	8527,10	kN
Characteristic moment resistance	$M_{y,Rk}$	1052,93	kNm
Characteristic moment resistance	$M_{z,Rk}$	495,94	kNm
Reduction factor	χ_y	0,52	
Reduction factor	χ_z	0,45	
Modified reduction factor	$\chi_{LT,mod}$	1,00	
Interaction factor	k_{yy}	1,05	
Interaction factor	k_{yz}	0,81	
Interaction factor	k_{zy}	0,60	
Interaction factor	k_{zz}	0,96	

Maximum moment $M_{y,Ed}$ is derived from beam B5410 position 0,000 m.

Maximum moment $M_{z,Ed}$ is derived from beam B5409 position 0,000 m.

Interaction method 1 parameters			
Critical Euler load	$N_{cr,y}$	6786,27	kN
Critical Euler load	$N_{cr,z}$	6323,38	kN
Elastic critical load	$N_{cr,T}$	32802,83	kN
Plastic section modulus	$W_{pl,y}$	2,9660e-03	m^3
Elastic section modulus	$W_{el,y}$	2,5510e-03	m^3
Plastic section modulus	$W_{pl,z}$	1,3970e-03	m^3
Elastic section modulus	$W_{el,z}$	9,1410e-04	m^3
Second moment of area	I_y	3,9600e-04	m^4
Second moment of area	I_z	1,3200e-04	m^4
Torsional constant	I_t	8,0730e-06	m^4
Method for equivalent moment factor $C_{my,0}$		Table A.2 Line 2 (General)	
Design bending moment (maximum)	$M_{y,Ed}$	420,94	kNm
Maximum relative deflection	δ_z	4,3	mm
Equivalent moment factor	$C_{my,0}$	0,91	
Method for equivalent moment factor $C_{mz,0}$		Table A.2 Line 2 (General)	
Design bending moment (maximum)	$M_{z,Ed}$	176,24	kNm
Maximum relative deflection	δ_y	-2,8	mm
Equivalent moment factor	$C_{mz,0}$	0,90	
Factor	μ_y	0,95	
Factor	μ_z	0,94	
Factor	ϵ_y	5,82	
Factor	a_{LT}	0,98	
Critical moment for uniform bending	$M_{cr,0}$	1614,41	kNm
Relative slenderness	$\lambda_{rel,0}$	0,81	
Limit relative slenderness	$\lambda_{rel,0,lim}$	0,27	
Equivalent moment factor	C_{my}	0,97	
Equivalent moment factor	C_{mz}	0,90	
Equivalent moment factor	C_{mLT}	1,00	
Factor	b_{LT}	0,05	
Factor	c_{LT}	0,38	
Factor	d_{LT}	0,13	
Factor	e_{LT}	0,29	

Interaction method 1 parameters			
Factor	w_y	1,16	
Factor	w_z	1,50	
Factor	η_{pl}	0,08	
Maximum relative slenderness	$\lambda_{rel,max}$	1,16	
Factor	C_{yy}	0,98	
Factor	C_{yz}	0,81	
Factor	C_{zy}	0,89	
Factor	C_{zz}	0,98	

Unity check (6.61) = $0,15 + 0,42 + 0,29 = 0,86$ -

Unity check (6.62) = $0,18 + 0,24 + 0,34 = 0,76$ -

Shear Buckling check

According to EN 1993-1-5 article 5 & 7.1 and formula (5.10) & (7.1)

Shear Buckling parameters			
Buckling field length	a	3,000	m
Web		unstiffened	
Web height	h_w	244	mm
Web thickness	t	19	mm
Material coefficient	ϵ	0,81	
Shear correction factor	η	1,20	

Shear Buckling verification		
Web slenderness	h_w/t	13,19
Web slenderness limit		48,82

Note: The web slenderness is such that Shear Buckling effects may be ignored according to EN 1993-1-5 article 5.1(2).

The member satisfies the stability check.

Student version

Student version

8. Težina konstrukcije

Bill of material

Selection: All
Type of sorting: Material

Summary

Material	Mass [kg]	Surface [m ²]	Volume [m ³]
Steel	749360,8	11675,338	9,5460e+01
Total	749360,8	11675,338	9,5460e+01

Note: Value 'Surface' represents for 1D members the total exposed surface area, while for 2D members it corresponds only to the surface area of the centroidal plane.

Steel (1D)

Material	Density [kg/m ³]	Mass [kg]	Surface [m ²]	Volume [m ³]
S 355	7850,0	749360,8	11675,338	9,5460e+01
Total		749360,8	11675,338	9,5460e+01

Slika 8.1. Iskaz materijala

Iz Slike 8.1. vidljivo je da je ukupna masa čeličnog dijela konstrukcije 749360,8 kg, pri ukupnoj tlocrtnoj površini po kojoj se definiraju čelični elementi 8000 m² pri čemu dobijemo masu po metru kvadratnom površine (uz dodatnih 15% kada uračunamo težine priključaka odnosno pločica i vijaka):

$$\frac{1,15 \cdot 749360,80 \text{ kg}}{8000 \text{ m}^2} = 107,72 \text{ kg/m}^2$$

9. Proračun spojeva

9.1. Spoj velikog stupa s temeljem

Project:
Project no:
Author:



Material

Steel S 355
Concrete C35/45

Project item Con N2225

Design

Name Con N2225
Description
Analysis Stress, strain/ loads in equilibrium

Beams and columns

Name	Cross-section	β - Direction [°]	γ - Pitch [°]	α - Rotation [°]	Offset ex [mm]	Offset ey [mm]	Offset ez [mm]	Forces in
B2427	1 - CFRHS180X120X10(RHS180x120)	0,0	0,0	0,0	0	0	0	Position

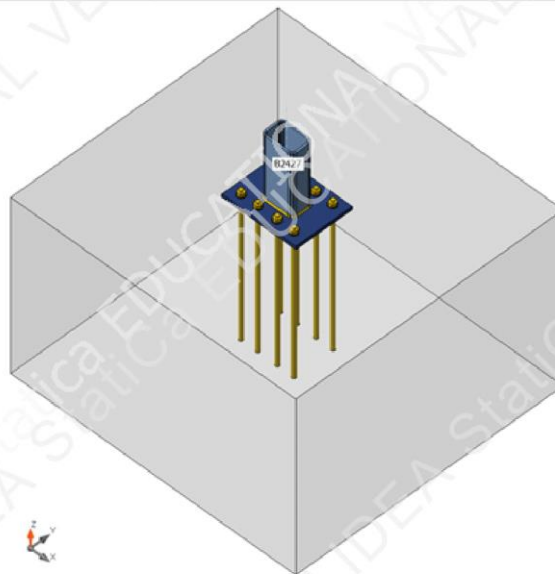

Cross-sections

Name	Material
1 - CFRHS180X120X10(RHS180x120)	S 355

Project:
Project no:
Author:

Cross-sections

Name	Material	Drawing
1 - CFRHS180X120X10(RHS180x120)	S 355	

Anchors

Name	Bolt assembly	Diameter [mm]	fu [MPa]	Gross area [mm ²]
M22 10.9	M22 10.9	22	1000,0	380

Load effects (forces in equilibrium)

Name	Member	N [kN]	Vy [kN]	Vz [kN]	Mx [kNm]	My [kNm]	Mz [kNm]
ULS-Set(1)	B2427	-1,9	-3,1	-2,5	0,0	8,1	-6,7
ULS-Set(2)	B2427	-28,5	0,0	5,0	-0,2	-14,5	-0,3
ULS-Set(3)	B2427	-21,0	-5,6	12,2	-0,2	-15,7	-12,3
ULS-Set(4)	B2427	-12,0	2,8	16,6	-0,2	-34,4	5,2
ULS-Set(5)	B2427	-11,0	0,0	-9,4	-0,1	11,7	-0,1
ULS-Set(6)	B2427	-17,6	1,2	22,3	-0,2	-42,7	0,8
ULS-Set(7)	B2427	-25,2	1,1	16,7	-0,3	-35,7	0,7
ULS-Set(8)	B2427	-3,6	0,1	-4,8	0,0	6,3	0,0
ULS-Set(9)	B2427	-19,3	2,4	20,4	-0,3	-42,3	3,1
ULS-Set(10)	B2427	-25,4	2,8	14,8	-0,3	-34,7	5,0

Foundation block

Item	Value	Unit
CB 1		
Dimensions	1520 x 1620	mm
Depth	1000	mm
Anchor	M22 10.9	
Anchoring length	800	mm
Shear force transfer	Anchors	

Project:
 Project no:
 Author:

Check

Summary

Name	Value	Status
Analysis	100,0%	OK
Plates	0,0 < 5,0%	OK
Anchors	98,8 < 100%	OK
Welds	99,5 < 100%	OK
Concrete block	46,3 < 100%	OK
Buckling	Not calculated	

Plates

Name	Thickness [mm]	Loads	σ_{Ed} [MPa]	ϵ_{pl} [%]	σ_{CEd} [MPa]	Status
B2427	10,0	ULS-Set(6)	218,4	0,0	0,0	OK
BP1	20,0	ULS-Set(6)	355,1	0,0	0,0	OK

Design data

Material	f_y [MPa]	ϵ_{lim} [%]
S 355	355,0	5,0

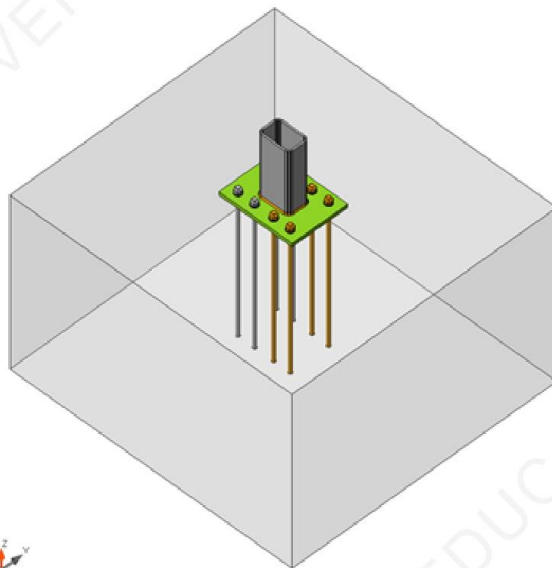

Overall check, ULS-Set(6)

Project:
Project no:
Author:

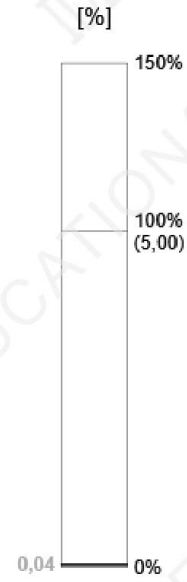
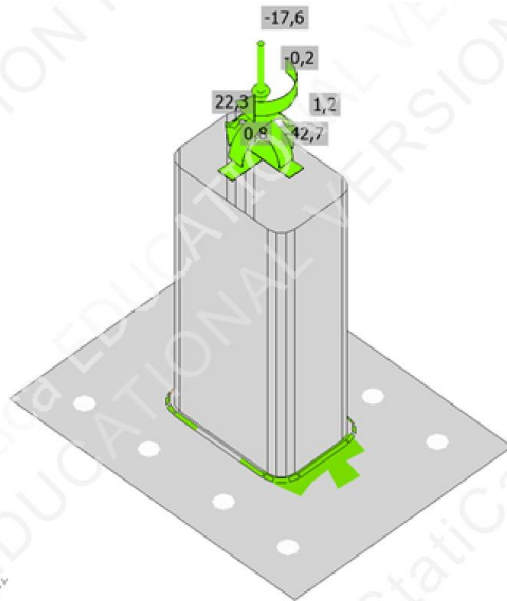

Strain check, ULS-Set(6)

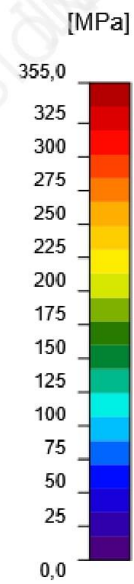
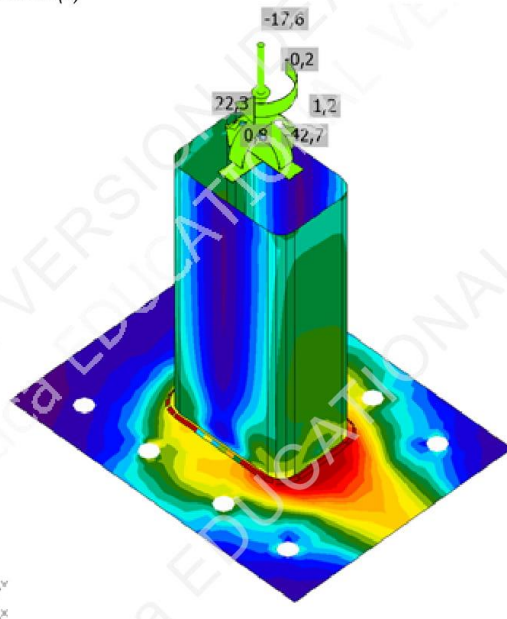

Equivalent stress, ULS-Set(6)

Project:
Project no:
Author:

Anchors

Shape	Item	Loads	N _{Ed} [kN]	V _{Ed} [kN]	N _{Rd,c} [kN]	V _{Rd,c} [kN]	V _{Rd,cp} [kN]	U _{t,t} [%]	U _{t,s} [%]	U _{t,ts} [%]	Status
	A1	ULS-Set(5)	16,0	1,2	285,5	-	656,8	23,8	1,4	11,7	OK
	A2	ULS-Set(5)	15,9	1,2	285,5	-	656,8	23,8	1,4	11,7	OK
	A3	ULS-Set(3)	14,7	1,4	284,6	-	656,8	38,4	2,0	24,1	OK
	A4	ULS-Set(4)	1,1	2,1	289,7	-	656,8	75,5	2,6	66,0	OK
	A5	ULS-Set(6)	66,0	2,8	285,3	228,0	656,8	97,1	9,8	98,8	OK
	A6	ULS-Set(6)	66,2	3,1	285,3	-	656,8	97,1	3,4	96,3	OK
	A7	ULS-Set(6)	70,7	2,6	285,3	228,0	656,8	97,1	9,8	98,8	OK
	A8	ULS-Set(6)	74,1	2,9	285,3	-	656,8	97,1	3,4	96,3	OK

Design data

Grade	N _{Rd,s} [kN]	V _{Rd,s} [kN]
M22 10.9 - 1	184,0	101,0

Welds (Plastic redistribution)

Item	Edge	Throat th. [mm]	Length [mm]	Loads	σ _{w,Ed} [MPa]	ε _{pI} [%]	σ _⊥ [MPa]	τ [MPa]	τ _⊥ [MPa]	U _t [%]	U _{t,c} [%]	Status
BP1	B2427	▲5,0	524	ULS-Set(9)	433,5	3,8	-265,2	-8,2	197,8	99,5	83,7	OK

Design data

	β _w [-]	σ _{w,Rd} [MPa]	0.9 σ [MPa]
S 355	0,90	435,6	352,8

Concrete block

Item	Loads	c [mm]	A _{eff} [mm ²]	σ [MPa]	k _j [-]	F _{jd} [MPa]	U _t [%]	Status
CB 1	ULS-Set(6)	32	14342	21,7	3,00	46,9	46,3	OK

Buckling

Buckling analysis was not calculated.

Bill of material

Manufacturing operations

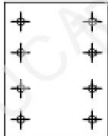
Name	Plates [mm]	Shape	Nr.	Welds [mm]	Length [mm]	Bolts	Nr.
BP1	P20,0x320,0-420,0 (S 355)		1	Fillet: a = 5,0	524,2	M22 10.9	8

Project:
Project no:
Author:



Welds

Type	Material	Throat thickness [mm]	Leg size [mm]	Length [mm]
Fillet	S 355	5,0	7,1	524,2

Anchors

Name	Length [mm]	Drill length [mm]	Count
M22 10.9	820	800	8

Code settings

Item	Value	Unit	Reference
YM0	1,00	-	EN 1993-1-1: 6.1
YM1	1,00	-	EN 1993-1-1: 6.1
YM2	1,25	-	EN 1993-1-1: 6.1
YM3	1,25	-	EN 1993-1-8: 2.2
YC	1,50	-	EN 1992-1-1: 2.4.2.4
YInst	1,20	-	EN 1992-4: Table 4.1
Joint coefficient β_j	0,67	-	EN 1993-1-8: 6.2.5
Effective area - influence of mesh size	0,10	-	
Friction coefficient - concrete	0,25	-	EN 1993-1-8
Friction coefficient in slip-resistance	0,30	-	EN 1993-1-8 tab 3.7
Limit plastic strain	0,05	-	EN 1993-1-5
Weld stress evaluation	Plastic redistribution		
Detailing	No		
Distance between bolts [d]	2,20	-	EN 1993-1-8: tab 3.3
Distance between bolts and edge [d]	1,20	-	EN 1993-1-8: tab 3.3
Concrete breakout resistance check	Both		EN 1992-4: 7.2.1.4 and 7.2.2.5
Use calculated a_b in bearing check.	Yes		EN 1993-1-8: tab 3.4
Cracked concrete	Yes		EN 1992-4
Local deformation check	No		CIDECT DG 1, 3 - 1.1
Local deformation limit	0,03	-	CIDECT DG 1, 3 - 1.1
Geometrical nonlinearity (GMNA)	Yes		Allow large deformations of hollow sections
Braced system	No		EN 1993-1-8: 5.2.2.5

9.2. Spoj malog stupa s temeljem

Project:
Project no:
Author:

IDEA StatiCa®
Calculate yesterday's estimates

Material

Steel S 355
Concrete C35/45

Project item Con N336

Design

Name Con N336
Description
Analysis Stress, strain/ loads in equilibrium

Beams and columns

Name	Cross-section	β - Direction [°]	γ - Pitch [°]	α - Rotation [°]	Offset ex [mm]	Offset ey [mm]	Offset ez [mm]	Forces in
B466	1 - CFRHS120X120X6(RHS120x120)	0,0	0,0	0,0	0	0	0	Position

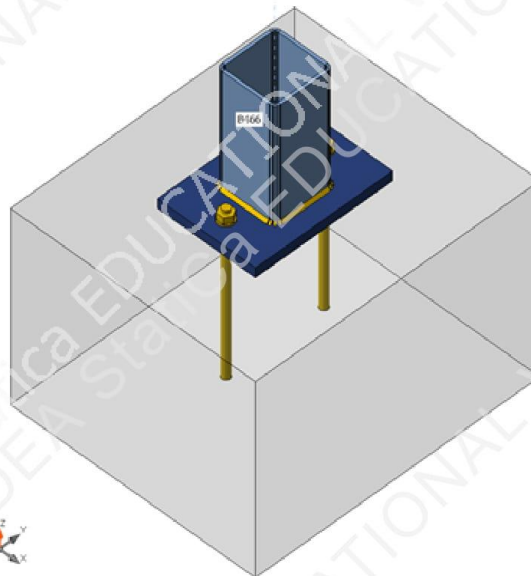

Cross-sections

Name	Material
1 - CFRHS120X120X6(RHS120x120)	S 355

Project:
Project no:
Author:

Cross-sections

Name	Material	Drawing
1 - CFRHS120X120X6(RHS120x120)	S 355	

Anchors

Name	Bolt assembly	Diameter [mm]	fu [MPa]	Gross area [mm ²]
M16 10.9	M16 10.9	16	1000,0	201

Load effects (forces in equilibrium)

Name	Member	N [kN]	Vy [kN]	Vz [kN]	Mx [kNm]	My [kNm]	Mz [kNm]
ULS-Set(1)	B466	-7,0	-4,5	0,0	0,0	0,0	0,0
ULS-Set(2)	B466	-35,1	-1,2	0,0	0,0	0,0	0,0
ULS-Set(3)	B466	-18,7	-6,8	0,0	0,0	0,0	0,0
ULS-Set(4)	B466	-16,7	-2,2	0,0	0,0	0,0	0,0
ULS-Set(5)	B466	-14,0	3,7	0,0	0,0	0,0	0,0
ULS-Set(6)	B466	-27,5	3,9	0,0	0,0	0,0	0,0
ULS-Set(7)	B466	-23,3	-6,4	0,0	0,0	0,0	0,0
ULS-Set(8)	B466	-12,0	-2,7	0,0	0,0	0,0	0,0
ULS-Set(9)	B466	-27,8	-6,7	0,0	0,0	0,0	0,0
ULS-Set(10)	B466	-27,5	0,3	0,0	0,0	0,0	0,0

Foundation block

Item	Value	Unit
CE 1		
Dimensions	580 x 500	mm
Depth	400	mm
Anchor	M16 10.9	
Anchoring length	300	mm
Shear force transfer	Anchors	

Project:
 Project no:
 Author:

Check

Summary

Name	Value	Status
Analysis	100,0%	OK
Plates	0,0 < 5,0%	OK
Anchors	30,3 < 100%	OK
Welds	10,7 < 100%	OK
Concrete block	2,7 < 100%	OK
Buckling	Not calculated	

Plates

Name	Thickness [mm]	Loads	σ_{Ed} [MPa]	ϵ_{pI} [%]	σ_{cEd} [MPa]	Status
B466	6,0	ULS-Set(9)	39,2	0,0	0,0	OK
BP1	20,0	ULS-Set(9)	9,2	0,0	0,0	OK

Design data

Material	f_y [MPa]	ϵ_{lim} [%]
S 355	355,0	5,0

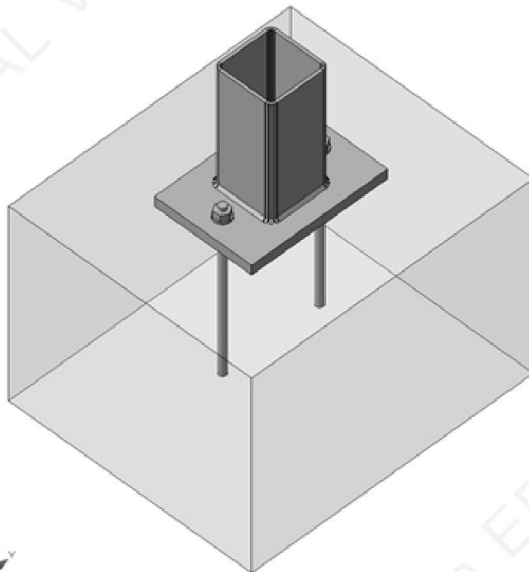

Overall check, ULS-Set(9)

Project:
Project no:
Author:

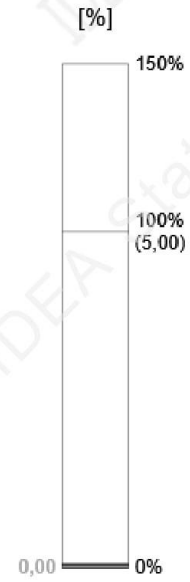
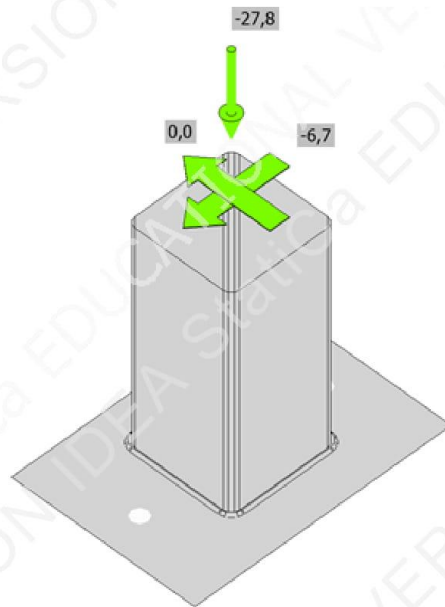

Strain check, ULS-Set(9)

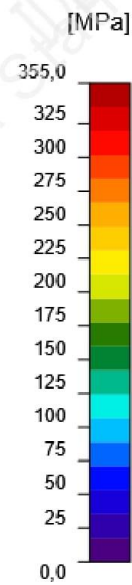
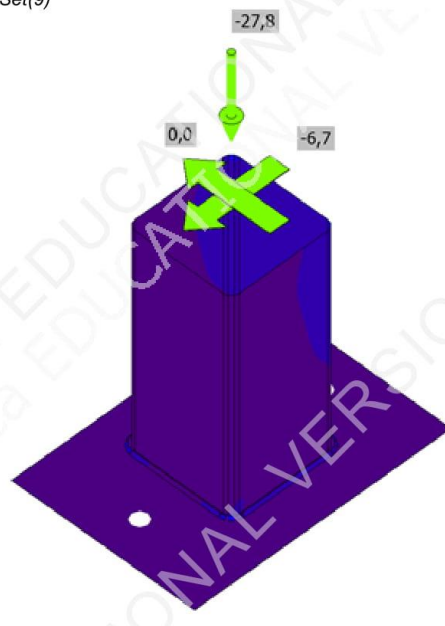

Equivalent stress, ULS-Set(9)

Project:
Project no:
Author:

Anchors

Shape	Item	Loads	N _{Ed} [kN]	V _{Ed} [kN]	V _{Rd,c} [kN]	V _{Rd,cp} [kN]	U _t [%]	U _{t_s} [%]	U _{t_{ts}} [%]	Status
	A1	ULS-Set(6)	0,0	1,9	22,4	117,0	0,0	17,4	7,2	OK
	A2	ULS-Set(3)	0,0	3,4	22,4	117,0	0,0	30,3	16,7	OK

Design data

Grade	N _{Rd,s} [kN]	V _{Rd,s} [kN]
M16 10.9 - 1	95,3	52,3

Welds (Plastic redistribution)

Item	Edge	Throat th. [mm]	Length [mm]	Loads	σ _{w,Ed} [MPa]	ε _{pl} [%]	σ _⊥ [MPa]	τ [MPa]	τ _⊥ [MPa]	U _t [%]	U _{t_c} [%]	Status
BP1	B466	▲4,0	440	ULS-Set(2)	46,6	0,0	-29,9	-9,0	18,5	10,7	6,4	OK

Design data

	β _w [-]	σ _{w,Rd} [MPa]	0.9 σ [MPa]
S 355	0,90	435,6	352,8

Concrete block

Item	Loads	c [mm]	A _{eff} [mm ²]	σ [MPa]	k _j [-]	F _{jd} [MPa]	U _t [%]	Status
CB 1	ULS-Set(2)	34	32366	1,1	2,58	40,3	2,7	OK

Buckling

Buckling analysis was not calculated.

Bill of material

Manufacturing operations

Name	Plates [mm]	Shape	Nr.	Welds [mm]	Length [mm]	Bolts	Nr.
BP1	P20,0x280,0-200,0 (S 355)		1	Fillet: a = 4,0	439,9	M16 10.9	2

Welds

Type	Material	Throat thickness [mm]	Leg size [mm]	Length [mm]
Fillet	S 355	4,0	5,7	439,9

Project:
Project no:
Author:

Anchors

Name	Length [mm]	Drill length [mm]	Count
M16 10.9	320	300	2

Code settings

Item	Value	Unit	Reference
YM0	1,00	-	EN 1993-1-1: 6.1
YM1	1,00	-	EN 1993-1-1: 6.1
YM2	1,25	-	EN 1993-1-1: 6.1
YM3	1,25	-	EN 1993-1-8: 2.2
YC	1,50	-	EN 1992-1-1: 2.4.2.4
YInst	1,20	-	EN 1992-4: Table 4.1
Joint coefficient β_j	0,67	-	EN 1993-1-8: 6.2.5
Effective area - influence of mesh size	0,10	-	
Friction coefficient - concrete	0,25	-	EN 1993-1-8
Friction coefficient in slip-resistance	0,30	-	EN 1993-1-8 tab 3.7
Limit plastic strain	0,05	-	EN 1993-1-5
Weld stress evaluation	Plastic redistribution		
Detailing	No		
Distance between bolts [d]	2,20	-	EN 1993-1-8: tab 3.3
Distance between bolts and edge [d]	1,20	-	EN 1993-1-8: tab 3.3
Concrete breakout resistance check	Both		EN 1992-4: 7.2.1.4 and 7.2.2.5
Use calculated ϕ_b in bearing check.	Yes		EN 1993-1-8: tab 3.4
Cracked concrete	Yes		EN 1992-4
Local deformation check	No		CIDECT DG 1, 3 - 1.1
Local deformation limit	0,03	-	CIDECT DG 1, 3 - 1.1
Geometrical nonlinearity (GMNA)	Yes		Allow large deformations of hollow sections
Braced system	No		EN 1993-1-8: 5.2.2.5

9.3. Spoj velikog stupa s donjim pojasom glavne rešetke

Project:
Project no:
Author:



Material

Steel S 355

Project item Con N239

Design

Name Con N239
Description
Analysis Stress, strain/ loads in equilibrium

Beams and columns

Name	Cross-section	β - Direction [°]	γ - Pitch [°]	α - Rotation [°]	Offset ex [mm]	Offset ey [mm]	Offset ez [mm]	Forces in
B330	1 - CFRHS180X120X10(RHS180x120)	0,0	0,0	0,0	0	0	0	Position
B348	2 - CFRHS200X100X12.5(RHS200x100)	0,0	0,0	0,0	0	0	0	Position
B5094	2 - CFRHS200X100X12.5(RHS200x100)	0,0	0,0	0,0	0	0	0	Position

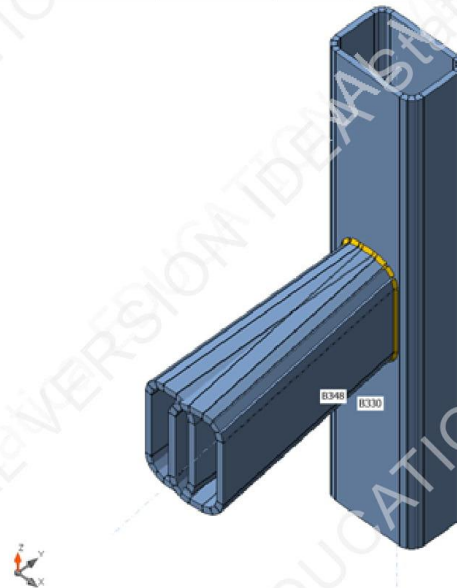

Project:
 Project no:
 Author:

Cross-sections

Name	Material
1 - CFRHS180X120X10(RHS180x120)	S 355
2 - CFRHS200X100X12.5(RHS200x100)	S 355

Cross-sections

Name	Material	Drawing
1 - CFRHS180X120X10(RHS180x120)	S 355	
2 - CFRHS200X100X12.5(RHS200x100)	S 355	

Project:
Project no:
Author:

Load effects (forces in equilibrium)

Name	Member	N [kN]	Vy [kN]	Vz [kN]	Mx [kNm]	My [kNm]	Mz [kNm]
ULS-Set(1)	B330	4,9	-5,4	0,1	0,0	0,2	8,8
	B348	-50,2	-0,5	-2,2	0,5	4,6	-0,4
	B5094	-42,7	0,1	-4,0	-0,4	-6,1	-0,1
ULS-Set(2)	B330	72,6	-2,7	-0,2	0,1	-0,7	7,7
	B348	-45,7	-0,3	-3,2	-0,4	5,1	-0,2
	B5094	-38,4	0,3	-4,3	1,0	-5,6	-0,2
ULS-Set(3)	B330	36,6	-6,5	-0,3	0,1	-1,0	8,5
	B348	-35,8	-0,2	-3,7	-0,8	6,9	-0,2
	B5094	-18,3	0,9	-4,4	1,5	-6,6	-0,8
ULS-Set(4)	B330	25,7	-5,0	-0,3	0,1	-1,0	5,8
	B348	-44,3	-0,3	-2,9	-0,9	5,3	-0,3
	B5094	-29,2	1,1	-3,4	1,5	-4,7	-1,0
ULS-Set(5)	B330	31,4	-1,8	-0,3	0,1	-0,9	2,3
	B348	-47,3	-0,3	-1,8	-1,0	3,0	-0,2
	B5094	-38,1	1,1	-2,1	1,5	-2,1	-0,9
ULS-Set(6)	B330	24,0	0,9	-0,2	0,1	-0,6	-0,4
	B348	-55,0	-0,4	-0,5	-0,7	0,5	-0,2
	B5094	-53,2	0,9	-1,0	1,0	0,0	-0,7
ULS-Set(7)	B330	22,0	2,7	0,0	0,1	-0,1	-1,1
	B348	-59,0	-0,5	0,4	-0,2	-1,2	-0,2
	B5094	-64,2	0,4	-0,5	0,2	0,9	-0,2
ULS-Set(8)	B330	52,2	2,0	0,0	0,1	-0,1	2,2
	B348	-64,0	-0,5	-0,8	-0,1	0,5	-0,2
	B5094	-68,5	0,2	-2,1	0,2	-1,3	0,0
ULS-Set(9)	B330	70,5	-0,9	0,0	0,0	-0,1	7,1
	B348	-49,7	-0,4	-2,3	0,2	3,5	-0,2
	B5094	-49,4	-0,2	-3,9	0,2	-4,7	0,3
ULS-Set(10)	B330	62,9	-4,8	0,1	-0,1	0,2	12,6
	B348	-44,5	-0,4	-3,6	0,7	6,3	-0,3
	B5094	-39,6	-0,6	-5,7	-0,5	-8,5	0,5

Check

Summary

Name	Value	Status
Analysis	100,0%	OK
Plates	0,1 < 5,0%	OK
Welds	72,2 < 100%	OK
Buckling	Not calculated	
GMNA	Calculated	

Project:
 Project no:
 Author:

Plates

Name	Thickness [mm]	Loads	σ_{Ed} [MPa]	ϵ_{pl} [%]	σ_{CEd} [MPa]	Status
B330	10,0	ULS-Set(10)	355,1	0,1	0,0	OK
B348	12,5	ULS-Set(10)	257,9	0,0	0,0	OK
B5094	12,5	ULS-Set(3)	217,5	0,0	0,0	OK

Design data

Material	f_y [MPa]	ϵ_{lim} [%]
S 355	355,0	5,0

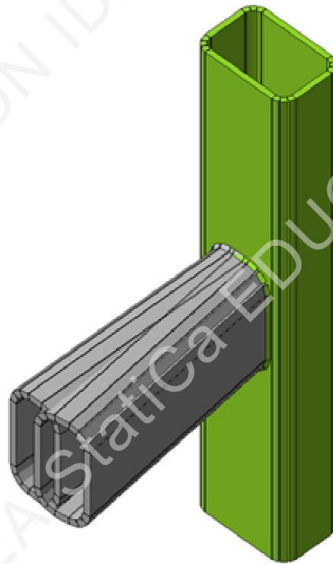

Overall check, ULS-Set(10)

Project:
 Project no:
 Author:

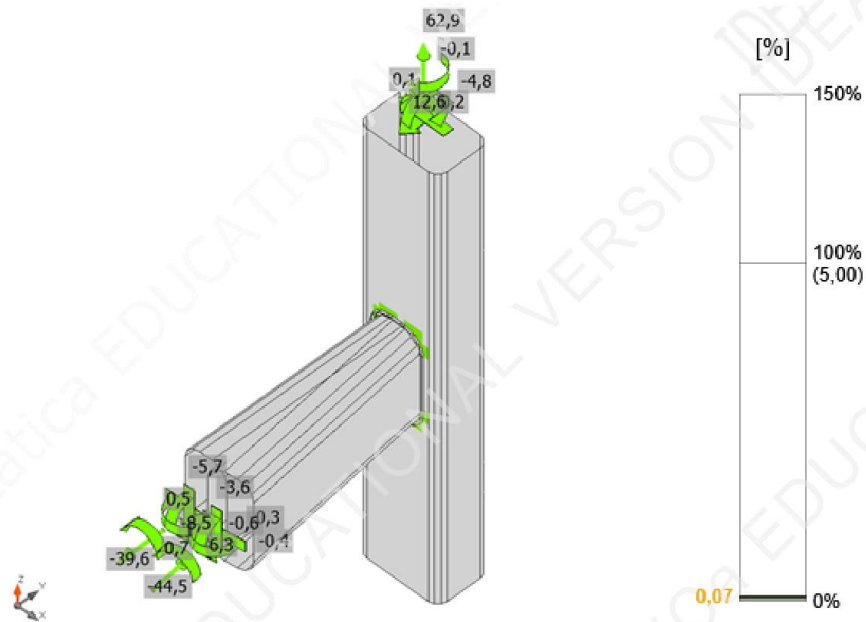

Strain check, ULS-Set(10)

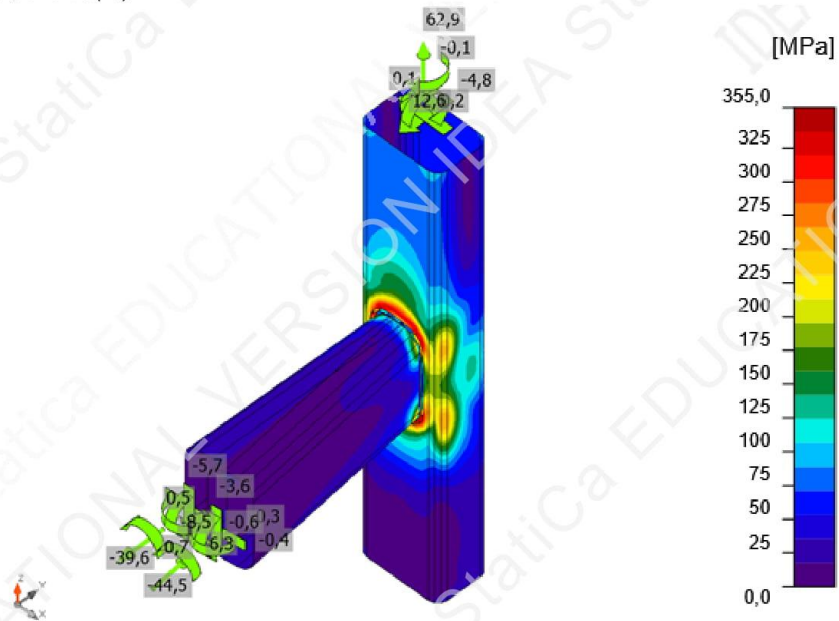

Equivalent stress, ULS-Set(10)

Project:
Project no:
Author:

Welds (Plastic redistribution)

Item	Edge	Throat th. [mm]	Length [mm]	Loads	$\sigma_{w,Ed}$ [MPa]	ϵ_{pl} [%]	σ_{\perp} [MPa]	τ_{\parallel} [MPa]	τ_{\perp} [MPa]	Ut [%]	Ut _c [%]	Status
B330-w 4	B348	▲4,0▲	495	ULS-Set(10)	137,6	0,0	14,2	-78,4	9,7	31,6	20,6	OK
B330-w 4	B5094	▲4,0▲	494	ULS-Set(10)	132,1	0,0	-76,1	-31,0	54,1	30,3	19,3	OK
		▲4,0▲	495	ULS-Set(10)	314,3	0,0	-246,5	36,6	106,5	72,2	22,5	OK
		▲4,0▲	494	ULS-Set(3)	260,0	0,0	-193,9	-45,1	89,3	59,7	20,1	OK

Design data

	β_w [-]	$\sigma_{w,Rd}$ [MPa]	0.9 σ [MPa]
S 355	0,90	435,6	352,8

Buckling

Buckling analysis was not calculated.

Bill of material

Manufacturing operations

Name	Plates [mm]	Shape	Nr.	Welds [mm]	Length [mm]	Bolts	Nr.
CUT1				Double fillet: a = 4,0	495,2		
CUT2				Double fillet: a = 4,0	494,1		

Welds

Type	Material	Throat thickness [mm]	Leg size [mm]	Length [mm]
Double fillet	S 355	4,0	5,7	989,3

Code settings

Item	Value	Unit	Reference
YM0	1,00	-	EN 1993-1-1: 6.1
YM1	1,00	-	EN 1993-1-1: 6.1
YM2	1,25	-	EN 1993-1-1: 6.1
YM3	1,25	-	EN 1993-1-8: 2.2
YC	1,50	-	EN 1992-1-1: 2.4.2.4
Y _{Inst}	1,20	-	EN 1992-4: Table 4.1
Joint coefficient β_j	0,67	-	EN 1993-1-8: 6.2.5
Effective area - influence of mesh size	0,10	-	
Friction coefficient - concrete	0,25	-	EN 1993-1-8
Friction coefficient in slip-resistance	0,30	-	EN 1993-1-8 tab 3.7
Limit plastic strain	0,05	-	EN 1993-1-5
Weld stress evaluation	Plastic redistribution		
Detailing	No		

Project:
Project no:
Author:



Item	Value	Unit	Reference
Distance between bolts [d]	2,20	-	EN 1993-1-8: tab 3.3
Distance between bolts and edge [d]	1,20	-	EN 1993-1-8: tab 3.3
Concrete breakout resistance check	Both		EN 1992-4: 7.2.1.4 and 7.2.2.5
Use calculated a_b in bearing check.	Yes		EN 1993-1-8: tab 3.4
Cracked concrete	Yes		EN 1992-4
Local deformation check	No		CIDECT DG 1, 3 - 1.1
Local deformation limit	0,03	-	CIDECT DG 1, 3 - 1.1
Geometrical nonlinearity (GMNA)	Yes		Allow large deformations of hollow sections
Braced system	No		EN 1993-1-8: 5.2.2.5

9.4. Nastavak gornjeg pojasa bočne rešetke

Project:
Project no:
Author:

IDEA StatiCa®
Calculate yesterday's estimates

Material

Steel S 355

Project item Con N318

Design

Name Con N318
Description
Analysis Stress, strain/ simplified loading

Beams and columns

Name	Cross-section	β - Direction [°]	γ - Pitch [°]	α - Rotation [°]	Offset ex [mm]	Offset ey [mm]	Offset ez [mm]	Forces in
B437	1 - CFRHS200X100X10(RHS200x100)	0,0	0,0	0,0	0	0	0	Position
B5207	1 - CFRHS200X100X10(RHS200x100)	0,0	0,0	0,0	0	0	0	Position

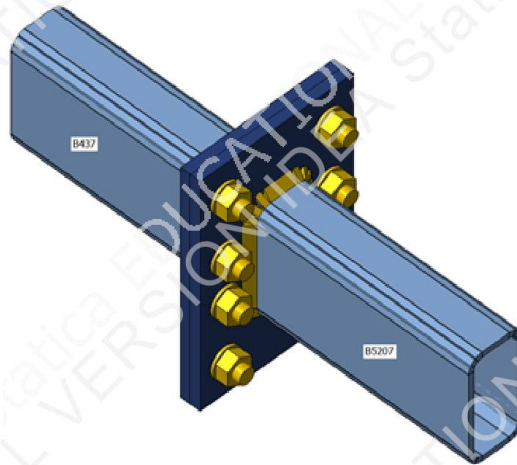

Cross-sections

Name	Material
1 - CFRHS200X100X10(RHS200x100)	S 355

Project:
Project no:
Author:

Cross-sections

Name	Material	Drawing
1 - CFRHS200X100X10(RHS200x100)	S 355	

Bolts

Name	Bolt assembly	Diameter [mm]	fu [MPa]	Gross area [mm ²]
M27 10.9	M27 10.9	27	1000,0	573

Load effects (equilibrium not required)

Name	Member	N [kN]	Vy [kN]	Vz [kN]	Mx [kNm]	My [kNm]	Mz [kNm]
ULS-Set(1)	B5207	1078,0	-0,1	13,8	-0,6	-9,5	0,3
ULS-Set(2)	B5207	-665,9	1,1	-10,4	-0,8	9,0	0,4
ULS-Set(3)	B5207	1076,6	-0,3	13,3	-0,8	-9,2	0,4
ULS-Set(4)	B5207	-664,5	1,2	-9,6	-0,7	8,5	0,2
ULS-Set(5)	B5207	1078,1	-0,1	13,8	-0,6	-9,5	0,3
ULS-Set(6)	B5207	-666,0	1,1	-10,4	-0,8	9,0	0,4
ULS-Set(7)	B5207	1077,6	0,1	12,0	-1,3	-7,8	0,7
ULS-Set(8)	B5207	-665,5	0,9	-8,5	-0,2	7,3	0,0
ULS-Set(9)	B5207	647,6	0,3	5,9	-1,4	-3,2	0,7
ULS-Set(10)	B5207	-397,3	0,7	-4,8	-0,1	4,4	0,0

Check

Summary

Name	Value	Status
Analysis	100,0%	OK
Plates	1,8 < 5,0%	OK
Bolts	97,8 < 100%	OK
Welds	98,5 < 100%	OK
Buckling	Not calculated	
GMNA	Calculated	

Project:
 Project no:
 Author:

Plates

Name	Thickness [mm]	Loads	σ_{Ed} [MPa]	ϵ_{pl} [%]	σ_{CEd} [MPa]	Status
B437	10,0	ULS-Set(5)	358,7	1,7	0,0	OK
B5207	10,0	ULS-Set(5)	358,6	1,7	0,0	OK
PP1a	18,0	ULS-Set(5)	358,7	1,8	81,7	OK
PP1b	18,0	ULS-Set(5)	358,7	1,8	81,7	OK

Design data

Material	f_y [MPa]	ϵ_{lim} [%]
S 355	355,0	5,0

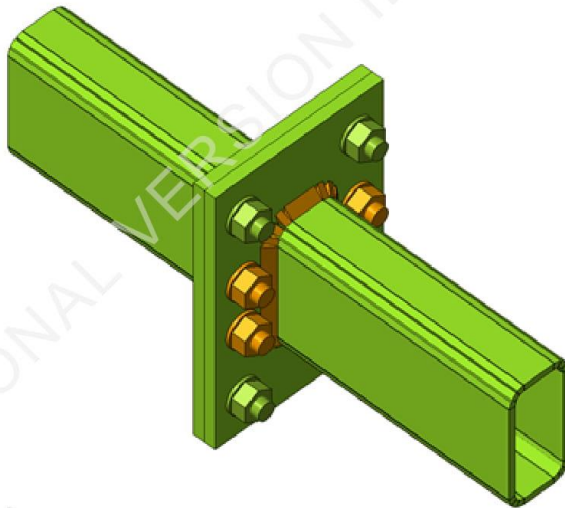

Overall check, ULS-Set(5)

Project:
Project no:
Author:

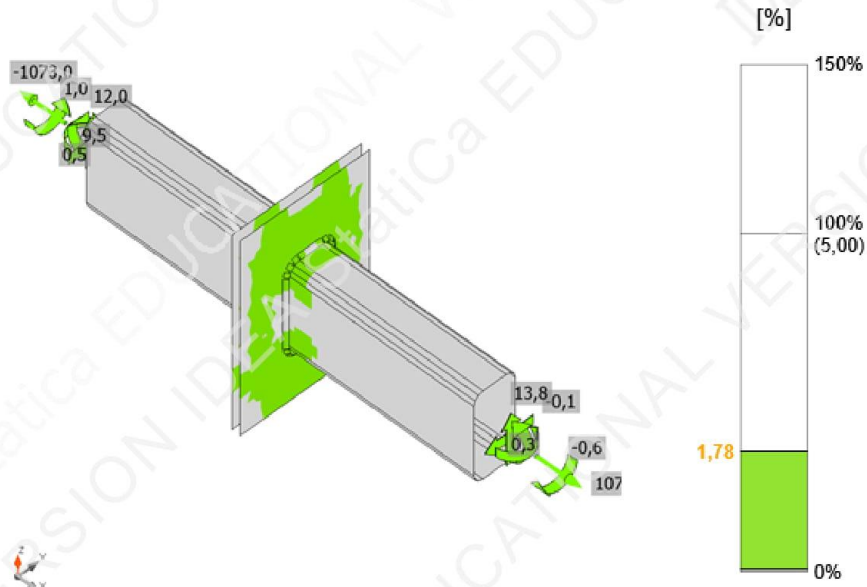

Strain check, ULS-Set(5)

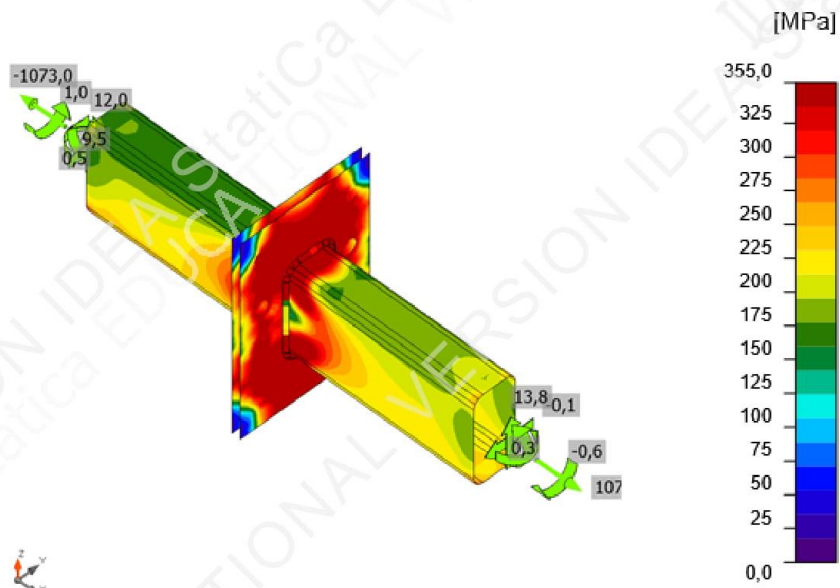

Equivalent stress, ULS-Set(5)

Project:
Project no:
Author:

Bolts

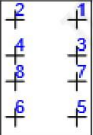
	Name	Loads	$F_{t,Ed}$ [kN]	V [kN]	U_{t_t} [%]	$F_{b,Rd}$ [kN]	U_{t_s} [%]	$U_{t_{ts}}$ [%]	Status
	B1	ULS-Set(7)	250,5	1,2	75,8	364,4	0,6	54,8	OK
	B2	ULS-Set(7)	251,8	3,2	76,2	350,8	1,7	56,2	OK
	B3	ULS-Set(7)	317,0	0,8	95,9	476,3	0,4	68,9	OK
	B4	ULS-Set(7)	317,7	1,9	96,1	304,3	1,0	69,7	OK
	B5	ULS-Set(5)	297,4	1,3	90,0	320,8	0,7	65,0	OK
	B6	ULS-Set(5)	297,4	2,5	90,0	339,2	1,3	65,6	OK
	B7	ULS-Set(5)	323,0	1,1	97,7	304,3	0,6	70,4	OK
	B8	ULS-Set(5)	323,3	1,6	97,8	304,3	0,9	70,8	OK

Design data

Name	$F_{t,Rd}$ [kN]	$B_{p,Rd}$ [kN]	$F_{v,Rd}$ [kN]
M27 10.9 - 1	330,5	644,1	183,6

Welds (Plastic redistribution)

Item	Edge	Throat th. [mm]	Length [mm]	Loads	$\sigma_{w,Ed}$ [MPa]	ϵ_{pl} [%]	σ_{\perp} [MPa]	$T_{ }$ [MPa]	T_{\perp} [MPa]	U_t [%]	U_{t_c} [%]	Status
PP1a	B437	▲10,0	524	ULS-Set(5)	429,2	1,4	176,2	-220,8	-48,1	98,5	78,3	OK
PP1b	B5207	▲10,0	524	ULS-Set(5)	429,1	1,3	179,4	220,0	-47,6	98,5	78,0	OK

Design data



	β_w [-]	$\sigma_{w,Rd}$ [MPa]	$0,9 \sigma$ [MPa]
S 355	0,90	435,6	352,8

Buckling

Buckling analysis was not calculated.

Bill of material

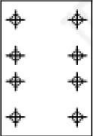
Manufacturing operations

Name	Plates [mm]	Shape	Nr.	Welds [mm]	Length [mm]	Bolts	Nr.
PP1	P18,0x280,0-420,0 (S 355)		1	Fillet: a = 10,0	1048,5	M27 10.9	8
	P18,0x280,0-420,0 (S 355)		1				

Project:
Project no:
Author:

Welds

Type	Material	Throat thickness [mm]	Leg size [mm]	Length [mm]
Fillet	S 355	10,0	14,1	1048,5

Bolts

Name	Grip length [mm]	Count
M27 10.9	36	8

Code settings

Item	Value	Unit	Reference
YM0	1,00	-	EN 1993-1-1: 6.1
YM1	1,00	-	EN 1993-1-1: 6.1
YM2	1,25	-	EN 1993-1-1: 6.1
YM3	1,25	-	EN 1993-1-8: 2.2
YC	1,50	-	EN 1992-1-1: 2.4.2.4
YInst	1,20	-	EN 1992-4: Table 4.1
Joint coefficient β_j	0,67	-	EN 1993-1-8: 6.2.5
Effective area - influence of mesh size	0,10	-	
Friction coefficient - concrete	0,25	-	EN 1993-1-8
Friction coefficient in slip-resistance	0,30	-	EN 1993-1-8 tab 3.7
Limit plastic strain	0,05	-	EN 1993-1-5
Weld stress evaluation	Plastic redistribution		
Detailing	No		
Distance between bolts [d]	2,20	-	EN 1993-1-8: tab 3.3
Distance between bolts and edge [d]	1,20	-	EN 1993-1-8: tab 3.3
Concrete breakout resistance check	Both		EN 1992-4: 7.2.1.4 and 7.2.2.5
Use calculated a_b in bearing check.	Yes		EN 1993-1-8: tab 3.4
Cracked concrete	Yes		EN 1992-4
Local deformation check	No		CIDECT DG 1, 3 - 1.1
Local deformation limit	0,03	-	CIDECT DG 1, 3 - 1.1
Geometrical nonlinearity (GMNA)	Yes		Allow large deformations of hollow sections
Braced system	No		EN 1993-1-8: 5.2.2.5

9.5. Nastavak donjeg pojasa bočne rešetke

Project:
Project no:
Author:



Material

Steel S 355

Project item Con N319

Design

Name Con N319
Description
Analysis Stress, strain/ loads in equilibrium

Beams and columns

Name	Cross-section	β - Direction [°]	γ - Pitch [°]	α - Rotation [°]	Offset ex [mm]	Offset ey [mm]	Offset ez [mm]	Forces in
B438	1 - CFRHS200X100X12.5(RHS200x100)	0,0	0,0	0,0	0	0	0	Position
B5210	1 - CFRHS200X100X12.5(RHS200x100)	0,0	0,0	0,0	0	0	0	Position

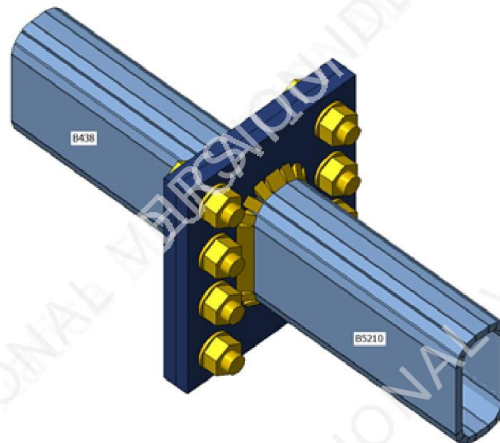

Cross-sections

Name	Material
1 - CFRHS200X100X12.5(RHS200x100)	S 355

Project:
Project no:
Author:

Cross-sections

Name	Material	Drawing
1 - CFRHS200X100X12.5(RHS200x100)	S 355	

Bolts

Name	Bolt assembly	Diameter [mm]	fu [MPa]	Gross area [mm ²]
M30 10.9	M30 10.9	30	1000,0	707

Load effects (forces in equilibrium)

Name	Member	N [kN]	Vy [kN]	Vz [kN]	Mx [kNm]	My [kNm]	Mz [kNm]
ULS-Set(1)	B438	-1290,3	3,2	13,2	2,7	11,3	-0,5
	B5210	1290,3	-2,9	15,3	-2,9	-11,3	0,3
ULS-Set(2)	B438	806,3	-0,6	-9,8	3,3	-6,9	-0,8
	B5210	-806,3	2,5	-9,1	-4,8	6,9	0,7
ULS-Set(3)	B438	-1287,1	3,8	13,0	4,4	11,3	-0,9
	B5210	1287,1	-2,7	15,5	-5,3	-11,3	0,7
ULS-Set(4)	B438	480,3	-1,0	-5,9	0,3	-4,1	0,0
	B5210	-480,3	1,0	-5,5	-0,4	4,1	0,0
ULS-Set(5)	B438	803,8	-1,3	-9,6	1,3	-6,9	-0,3
	B5210	-803,8	2,1	-9,2	-2,1	6,9	0,3
ULS-Set(6)	B438	-1289,7	3,2	13,3	2,4	11,3	-0,4
	B5210	1289,7	-3,0	15,4	-2,5	-11,3	0,2
ULS-Set(7)	B438	-1288,6	3,1	13,5	2,1	11,3	-0,4
	B5210	1288,6	-3,0	15,2	-2,1	-11,3	0,2
ULS-Set(8)	B438	806,3	-0,7	-9,8	3,3	-6,9	-0,8
	B5210	-806,3	2,5	-9,1	-4,8	6,9	0,7
ULS-Set(9)	B438	805,2	-0,5	-10,1	3,7	-6,9	-0,8
	B5210	-805,2	2,4	-9,0	-5,3	6,9	0,7
ULS-Set(10)	B438	-1286,9	3,8	13,0	4,4	11,3	-0,9
	B5210	1286,9	-2,7	15,5	-5,3	-11,3	0,7

Project:
 Project no:
 Author:

Check

Summary

Name	Value	Status
Analysis	100,0%	OK
Plates	2,8 < 5,0%	OK
Bolts	99,4 < 100%	OK
Welds	98,6 < 100%	OK
Buckling	Not calculated	
GMNA	Calculated	

Plates

Name	Thickness [mm]	Loads	σ_{Ed} [MPa]	ϵ_{pl} [%]	σ_{CEd} [MPa]	Status
B438	12,5	ULS-Set(1)	360,1	2,4	0,0	OK
B5210	12,5	ULS-Set(6)	360,0	2,4	0,0	OK
PP1a	22,0	ULS-Set(6)	360,9	2,8	77,5	OK
PP1b	22,0	ULS-Set(1)	360,9	2,8	77,5	OK

Design data

Material	f_y [MPa]	ϵ_{lim} [%]
S 355	355,0	5,0

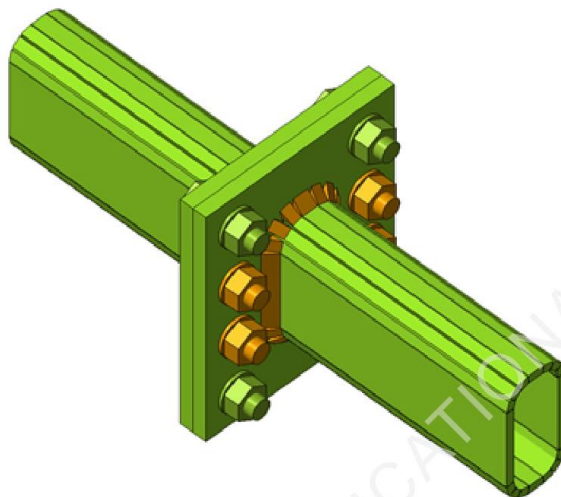

Overall check, ULS-Set(1)

Project:
 Project no:
 Author:

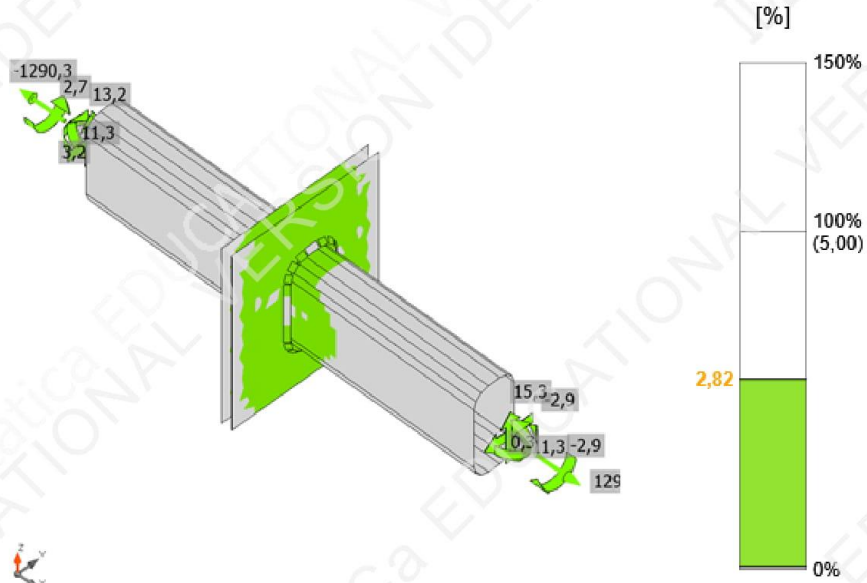

Strain check, ULS-Set(1)

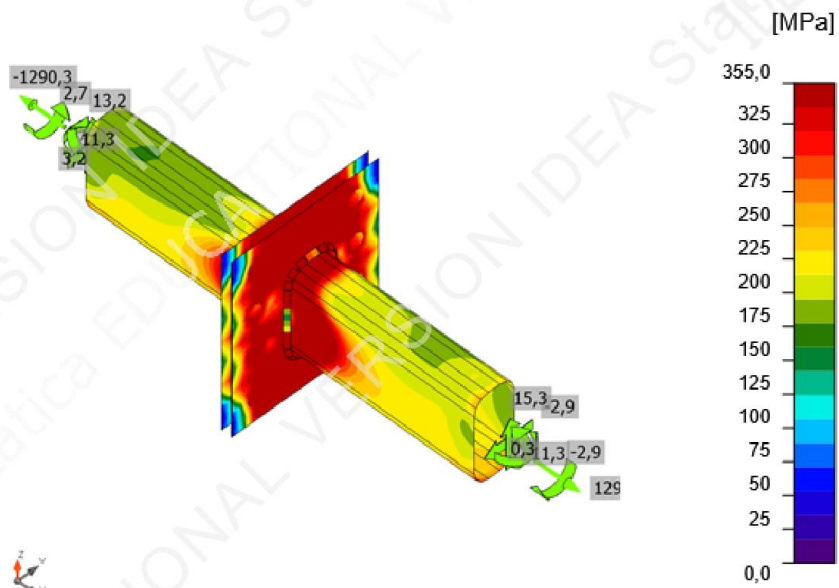

Equivalent stress, ULS-Set(1)

Project:
Project no:
Author:

Bolts

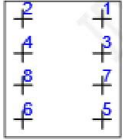
	Name	Loads	$F_{t,Ed}$ [kN]	V [kN]	U_{t_t} [%]	$F_{b,Rd}$ [kN]	U_{t_s} [%]	$U_{t_{ts}}$ [%]	Status
	B1	ULS-Set(6)	367,0	1,1	90,8	362,2	0,5	65,4	OK
	B2	ULS-Set(1)	367,1	5,1	90,9	370,3	2,3	67,2	OK
	B3	ULS-Set(6)	394,1	0,6	97,6	646,8	0,3	70,0	OK
	B4	ULS-Set(1)	394,3	3,1	97,6	426,3	1,4	71,1	OK
	B5	ULS-Set(6)	373,2	1,9	92,4	306,4	0,8	66,8	OK
	B6	ULS-Set(1)	373,1	4,9	92,4	416,3	2,2	68,2	OK
	B7	ULS-Set(6)	401,2	0,7	99,3	502,4	0,3	71,3	OK
	B8	ULS-Set(1)	401,3	3,1	99,4	646,8	1,4	72,4	OK

Design data

Name	$F_{t,Rd}$ [kN]	$B_{p,Rd}$ [kN]	$F_{v,Rd}$ [kN]
M30 10.9 - 1	403,9	856,4	224,4

Welds (Plastic redistribution)

Item	Edge	Throat th. [mm]	Length [mm]	Loads	$\sigma_{w,Ed}$ [MPa]	ϵ_{pl} [%]	σ_{\perp} [MPa]	τ_{\parallel} [MPa]	τ_{\perp} [MPa]	U_t [%]	U_{t_c} [%]	Status
PP1a	B438	▲12,0	494	ULS-Set(3)	429,4	1,5	292,5	-181,2	-9,7	98,6	79,2	OK
PP1b	B5210	▲12,0	494	ULS-Set(6)	429,1	1,3	313,7	168,6	-11,2	98,5	79,2	OK

Design data

	β_w [-]	$\sigma_{w,Rd}$ [MPa]	$0,9 \sigma$ [MPa]
S 355	0,90	435,6	352,8

Buckling

Buckling analysis was not calculated.

Bill of material

Manufacturing operations

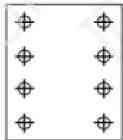
Name	Plates [mm]	Shape	Nr.	Welds [mm]	Length [mm]	Bolts	Nr.
PP1	P22,0x320,0-380,0 (S 355)		1	Fillet: a = 12,0	988,2	M30 10.9	8
	P22,0x320,0-380,0 (S 355)		1				

Project:
Project no:
Author:

Welds

Type	Material	Throat thickness [mm]	Leg size [mm]	Length [mm]
Fillet	S 355	12,0	17,0	988,2

Bolts

Name	Grip length [mm]	Count
M30 10.9	44	8

Code settings

Item	Value	Unit	Reference
YM0	1,00	-	EN 1993-1-1: 6.1
YM1	1,00	-	EN 1993-1-1: 6.1
YM2	1,25	-	EN 1993-1-1: 6.1
YM3	1,25	-	EN 1993-1-8: 2.2
YC	1,50	-	EN 1992-1-1: 2.4.2.4
YInst	1,20	-	EN 1992-4: Table 4.1
Joint coefficient β_j	0,67	-	EN 1993-1-8: 6.2.5
Effective area - influence of mesh size	0,10	-	
Friction coefficient - concrete	0,25	-	EN 1993-1-8
Friction coefficient in slip-resistance	0,30	-	EN 1993-1-8 tab 3.7
Limit plastic strain	0,05	-	EN 1993-1-5
Weld stress evaluation	Plastic redistribution		
Detailing	No		
Distance between bolts [d]	2,20	-	EN 1993-1-8: tab 3.3
Distance between bolts and edge [d]	1,20	-	EN 1993-1-8: tab 3.3
Concrete breakout resistance check	Both		EN 1992-4: 7.2.1.4 and 7.2.2.5
Use calculated α_b in bearing check.	Yes		EN 1993-1-8: tab 3.4
Cracked concrete	Yes		EN 1992-4
Local deformation check	No		CIDECT DG 1, 3 - 1.1
Local deformation limit	0,03	-	CIDECT DG 1, 3 - 1.1
Geometrical nonlinearity (GMNA)	Yes		Allow large deformations of hollow sections
Braced system	No		EN 1993-1-8: 5.2.2.5

9.6. Nastavak ispune bočne rešetke

Project:
Project no:
Author:



Material

Steel S 355

Project item nastavak ispune bocne

Design

Name nastavak ispune bocne
Description
Analysis Stress, strain/ loads in equilibrium

Beams and columns

Name	Cross-section	β - Direction [°]	γ - Pitch [°]	α - Rotation [°]	Offset ex [mm]	Offset ey [mm]	Offset ez [mm]	Forces in
B1	1 - RHSCF100/60/6.0	0,0	0,0	0,0	0	0	0	Node
B2	1 - RHSCF100/60/6.0	180,0	0,0	0,0	0	0	0	Node

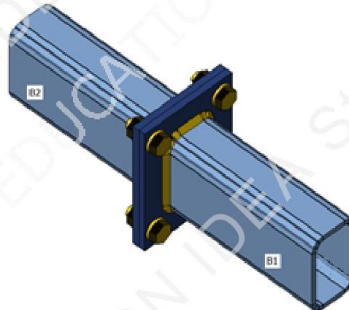

Cross-sections

Name	Material
1 - RHSCF100/60/6.0	S 355

Project:
Project no:
Author:

Cross-sections

Name	Material	Drawing
1 - RHSCF100/60/6.0	S 355	

Bolts

Name	Bolt assembly	Diameter [mm]	f_u [MPa]	Gross area [mm ²]
M12 10.9	M12 10.9	12	1000,0	113

Load effects (forces in equilibrium)

Name	Member	N [kN]	V _y [kN]	V _z [kN]	M _x [kNm]	M _y [kNm]	M _z [kNm]
LE1	B1	-44,4	-1,4	-0,1	0,3	0,0	-1,9
	B2	44,4	1,4	0,1	0,3	0,0	1,9

Check

Summary

Name	Value	Status
Analysis	100,0%	OK
Plates	0,0 < 5,0%	OK
Bolts	14,4 < 100%	OK
Welds	56,4 < 100%	OK
Buckling	Not calculated	
GMNA	Calculated	

Plates

Name	Thickness [mm]	Loads	σ_{Ed} [MPa]	ϵ_{pl} [%]	σ_{cEd} [MPa]	Status
B1	6,0	LE1	124,1	0,0	0,0	OK
B2	6,0	LE1	127,2	0,0	0,0	OK
PP1a	8,0	LE1	111,7	0,0	15,1	OK
PP1b	8,0	LE1	112,0	0,0	15,1	OK

Project:
 Project no:
 Author:

Design data

Material	f_y [MPa]	ϵ_{lim} [%]
S 355	355,0	5,0

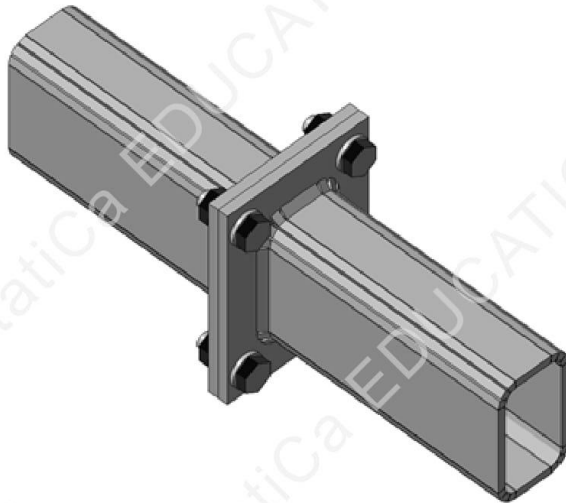

Overall check, LE1

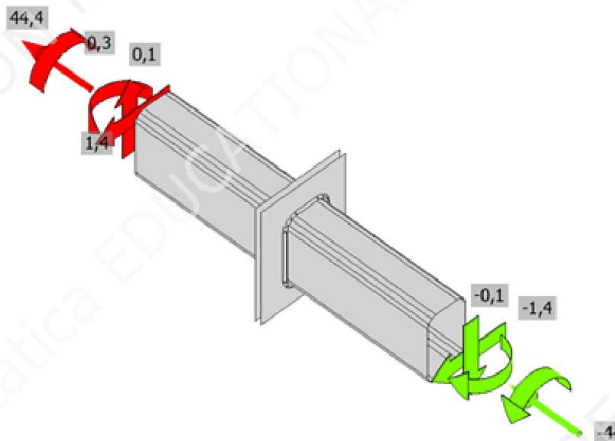

Strain check, LE1

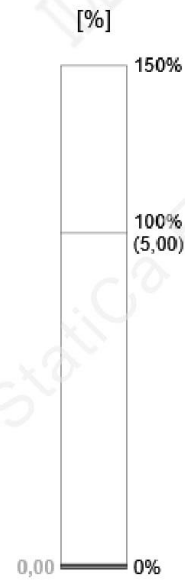

Project:
Project no:
Author:

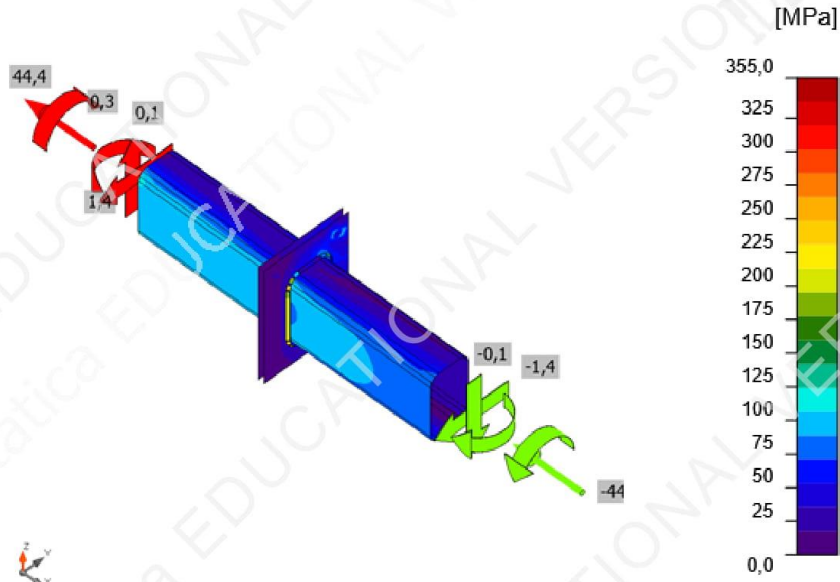

Equivalent stress, LE1

Bolts

	Name	Loads	$F_{t,Ed}$ [kN]	V [kN]	$U_{t,t}$ [%]	$F_{b,Rd}$ [kN]	$U_{t,s}$ [%]	$U_{t,s}$ [%]	Status
	B1	LE1	8,7	1,3	14,4	40,9	3,8	14,1	OK
	B2	LE1	0,1	1,3	0,1	41,6	3,9	4,0	OK
	B3	LE1	8,7	0,7	14,4	56,4	2,2	12,5	OK
	B4	LE1	0,1	0,8	0,1	51,5	2,3	2,4	OK

Design data

Name	$F_{t,Rd}$ [kN]	$B_{p,Rd}$ [kN]	$F_{v,Rd}$ [kN]
M12 10.9 - 1	60,5	136,0	33,6

Welds (Plastic redistribution)

Item	Edge	Throat th. [mm]	Length [mm]	Loads	$\sigma_{w,Ed}$ [MPa]	ϵ_{pl} [%]	σ_{\perp} [MPa]	τ_{\parallel} [MPa]	τ_{\perp} [MPa]	U_t [%]	$U_{t,c}$ [%]	Status
PP1a	B1	4,0	275	LE1	244,0	0,0	-145,3	-1,3	113,2	56,0	24,1	OK
PP1b	B2	4,0	275	LE1	245,6	0,0	-145,6	3,7	114,2	56,4	25,0	OK

Design data

	β_w [-]	$\sigma_{w,Rd}$ [MPa]	0.9σ [MPa]
S 355	0,90	435,6	352,8



Project:
Project no:
Author:

Buckling

Buckling analysis was not calculated.

Bill of material

Manufacturing operations

Name	Plates [mm]	Shape	Nr.	Welds [mm]	Length [mm]	Bolts	Nr.
PP1	P8,0x120,0-160,0 (S 355)		1	Fillet: a = 4,0	549,1	M12 10.9	4
	P8,0x120,0-160,0 (S 355)		1				

Welds

Type	Material	Throat thickness [mm]	Leg size [mm]	Length [mm]
Fillet	S 355	4,0	5,7	549,1

Bolts

Name	Grip length [mm]	Count
M12 10.9	16	4

Code settings

Item	Value	Unit	Reference
YM0	1,00	-	EN 1993-1-1: 6.1
YM1	1,00	-	EN 1993-1-1: 6.1
YM2	1,25	-	EN 1993-1-1: 6.1
YM3	1,25	-	EN 1993-1-8: 2.2
YC	1,50	-	EN 1992-1-1: 2.4.2.4
Yinst	1,20	-	EN 1992-4: Table 4.1
Joint coefficient β_j	0,67	-	EN 1993-1-8: 6.2.5
Effective area - influence of mesh size	0,10	-	
Friction coefficient - concrete	0,25	-	EN 1993-1-8
Friction coefficient in slip-resistance	0,30	-	EN 1993-1-8 tab 3.7
Limit plastic strain	0,05	-	EN 1993-1-5
Weld stress evaluation	Plastic redistribution		
Detailing	No		

Project:
Project no:
Author:



Item	Value	Unit	Reference
Distance between bolts [d]	2,20	-	EN 1993-1-8: tab 3.3
Distance between bolts and edge [d]	1,20	-	EN 1993-1-8: tab 3.3
Concrete breakout resistance check	Both		EN 1992-4: 7.2.1.4 and 7.2.2.5
Use calculated ab in bearing check.	Yes		EN 1993-1-8: tab 3.4
Cracked concrete	Yes		EN 1992-4
Local deformation check	No		CIDECT DG 1, 3 - 1.1
Local deformation limit	0,03	-	CIDECT DG 1, 3 - 1.1
Geometrical nonlinearity (GMNA)	Yes		Allow large deformations of hollow sections
Braced system	No		EN 1993-1-8: 5.2.2.5

9.7. Spoj donjeg pojasa bočne rešetke i ispuna

Project:
Project no:
Author:

IDEA StatiCa®
Calculate yesterday's estimates

Material

Steel S 355

Project item Con N239

Design

Name Con N239
Description
Analysis Stress, strain/ loads in equilibrium

Beams and columns

Name	Cross-section	β - Direction [°]	γ - Pitch [°]	α - Rotation [°]	Offset ex [mm]	Offset ey [mm]	Offset ez [mm]	Forces in
B414	3 - CFRHS100X60X6(RHS100x60)	0,0	0,0	0,0	0	0	0	Position
B416	3 - CFRHS100X60X6(RHS100x60)	0,0	0,0	0,0	0	0	0	Position
B423	3 - CFRHS100X60X6(RHS100x60)	0,0	0,0	0,0	0	0	0	Position
B5359	4 - CFRHS200X100X12.5(RHS200x100)	0,0	0,0	0,0	0	0	0	Position

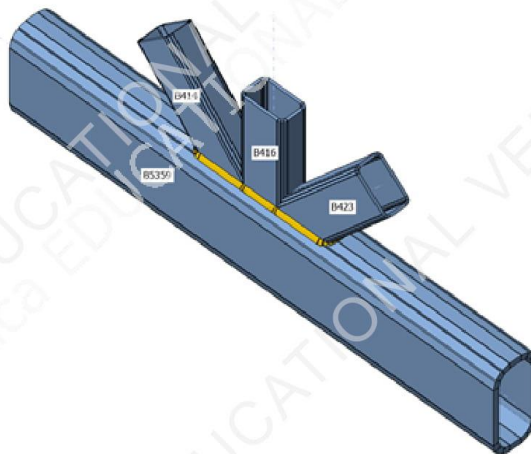

Project:
 Project no:
 Author:

Cross-sections

Name	Material
3 - CFRHS100X60X6(RHS100x60)	S 355
4 - CFRHS200X100X12.5(RHS200x100)	S 355

Cross-sections

Name	Material	Drawing
3 - CFRHS100X60X6(RHS100x60)	S 355	
4 - CFRHS200X100X12.5(RHS200x100)	S 355	

Project:
Project no:
Author:

Load effects (forces in equilibrium)

Name	Member	N [kN]	Vy [kN]	Vz [kN]	Mx [kNm]	My [kNm]	Mz [kNm]
ULS-Set(1)	B414	12,9	-0,3	-0,1	0,1	0,0	0,2
	B416	10,0	-0,5	0,0	0,0	0,0	-0,4
	B423	13,1	0,3	-0,1	-0,1	0,0	-0,2
	B5359	503,6	-0,5	5,6	-1,4	4,4	-0,3
ULS-Set(2)	B414	-17,8	-0,3	-0,1	0,0	0,0	0,2
	B416	-82,7	0,0	0,0	0,0	0,0	0,0
	B423	-32,7	0,0	-0,1	0,0	0,0	0,0
	B5359	-794,6	-2,0	-10,5	-2,6	-7,7	2,7
ULS-Set(3)	B414	-26,1	-0,8	-0,1	0,0	0,0	0,5
	B416	-53,2	-0,5	0,0	0,1	0,0	-0,4
	B423	-49,2	0,4	-0,1	0,0	0,0	-0,3
	B5359	-1318,3	-4,9	-16,7	-3,3	-12,7	5,7
ULS-Set(4)	B414	-25,0	-0,7	-0,1	0,0	0,0	0,5
	B416	-43,0	-0,4	0,0	0,1	0,0	-0,3
	B423	-48,8	0,3	-0,1	0,0	0,0	-0,2
	B5359	-1314,4	-4,5	-16,6	-2,7	-12,7	5,5
ULS-Set(5)	B414	-25,4	-0,4	-0,1	0,0	0,0	0,3
	B416	-50,9	-0,1	0,0	0,1	0,0	-0,1
	B423	-48,4	0,1	-0,1	0,0	0,0	-0,1
	B5359	-1314,2	-3,4	-16,6	-1,9	-12,6	4,7
ULS-Set(6)	B414	-14,1	-0,1	-0,1	0,0	0,0	0,1
	B416	-36,0	0,1	0,0	0,1	0,0	0,1
	B423	-29,9	-0,1	-0,1	0,0	0,0	0,1
	B5359	-783,4	-1,4	-10,1	-0,7	-7,6	2,3
ULS-Set(7)	B414	2,0	0,2	-0,1	0,0	0,0	-0,1
	B416	-21,2	0,3	0,0	0,0	0,0	0,2
	B423	-2,7	-0,3	-0,1	0,0	0,0	0,2
	B5359	9,2	1,1	-0,5	0,3	-0,2	-0,7
ULS-Set(8)	B414	0,2	0,2	-0,1	0,0	0,0	-0,2
	B416	-51,1	0,3	0,0	0,0	0,0	0,2
	B423	-4,7	-0,3	-0,1	0,0	0,0	0,2
	B5359	4,8	1,2	-0,7	-0,5	-0,2	-0,8
ULS-Set(9)	B414	-1,7	0,0	-0,1	0,0	0,0	-0,1
	B416	-67,9	0,2	0,0	0,0	0,0	0,1
	B423	-5,5	-0,2	-0,1	0,0	0,0	0,1
	B5359	-2,0	0,5	-0,8	-1,6	-0,2	-0,3
ULS-Set(10)	B414	8,3	-0,2	-0,1	0,1	0,0	0,0
	B416	-49,0	-0,2	0,0	-0,1	0,0	-0,2
	B423	11,0	0,1	-0,1	-0,1	0,0	-0,1
	B5359	491,1	0,5	5,2	-2,2	4,4	-1,1

Project:
 Project no:
 Author:

Check

Summary

Name	Value	Status
Analysis	100,0%	OK
Plates	0,0 < 5,0%	OK
Welds	76,5 < 100%	OK
Buckling	Not calculated	
GMNA	Calculated	

Plates

Name	Thickness [mm]	Loads	σ_{Ed} [MPa]	ϵ_{pl} [%]	σ_{Ed} [MPa]	Status
B414	6,0	ULS-Set(3)	311,3	0,0	0,0	OK
B416	6,0	ULS-Set(4)	305,7	0,0	0,0	OK
B423	6,0	ULS-Set(5)	301,0	0,0	0,0	OK
B5359	12,5	ULS-Set(3)	355,0	0,0	0,0	OK

Design data

Material	f_y [MPa]	ϵ_{lim} [%]
S 355	355,0	5,0

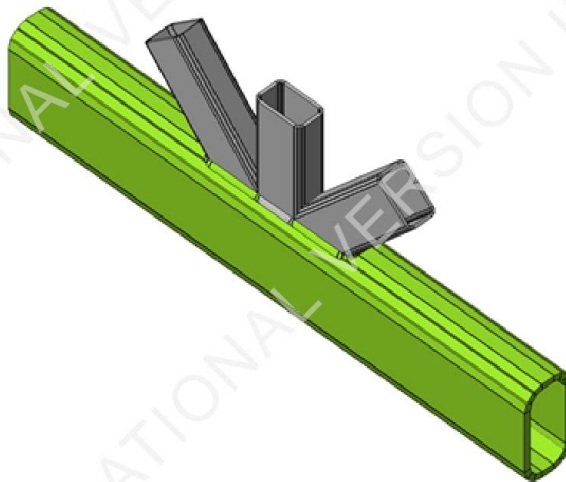

Overall check, ULS-Set(3)

Project:
 Project no:
 Author:

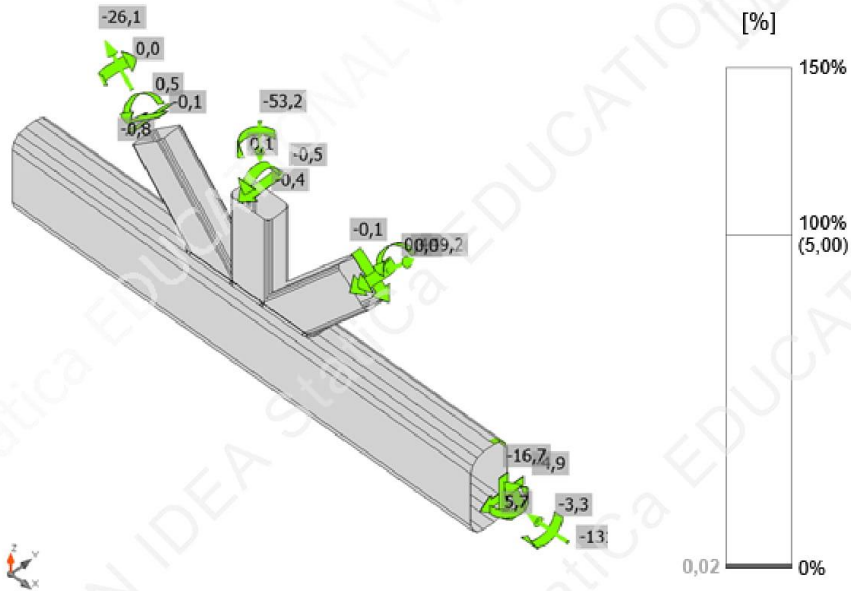

Strain check, ULS-Set(3)

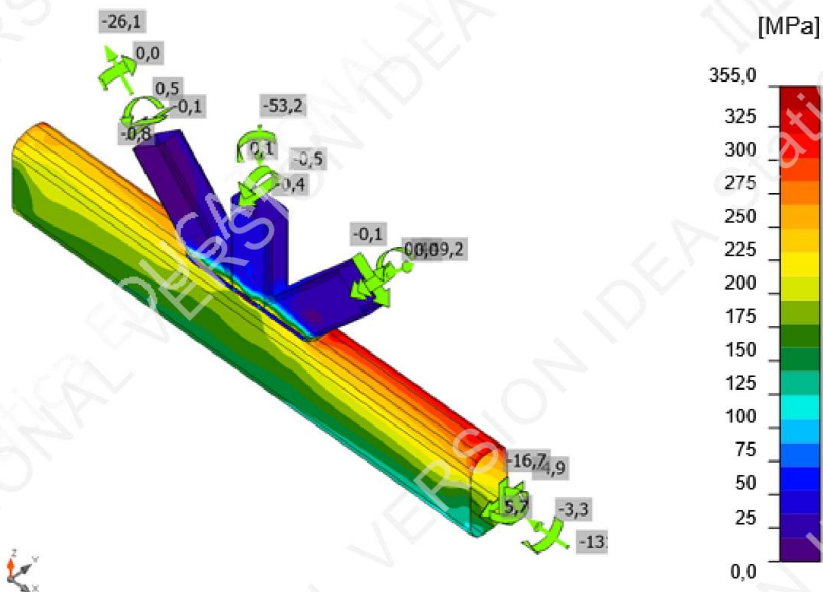

Equivalent stress, ULS-Set(3)

Project:
Project no:
Author:

Welds (Plastic redistribution)

Item	Edge	Throat th. [mm]	Length [mm]	Loads	$\sigma_{w,Ed}$ [MPa]	ϵ_{pl} [%]	σ_{\perp} [MPa]	$\tau_{ }$ [MPa]	τ_{\perp} [MPa]	Ut [%]	Ut _c [%]	Status
B5359-arc 6	B414	▲5,0▲	340	ULS-Set(5)	235,4	0,0	-0,4	-124,3	-55,1	54,0	20,5	OK
B5359-arc 6	B416	▲5,0▲	278	ULS-Set(5)	255,1	0,0	2,1	-104,5	-103,8	58,6	19,8	OK
B5359-arc 6	B423	▲5,0▲	340	ULS-Set(3)	222,3	0,0	-8,2	-100,8	-79,2	51,0	22,3	OK
		▲5,0▲	340	ULS-Set(4)	296,8	0,0	-97,5	145,2	-71,4	68,1	14,7	OK
		▲5,0▲	278	ULS-Set(5)	207,6	0,0	-119,8	85,1	48,4	47,7	16,4	OK
		▲5,0▲	340	ULS-Set(3)	333,2	0,0	-92,5	-163,2	-86,7	76,5	15,6	OK

Design data

	β_w [-]	$\sigma_{w,Rd}$ [MPa]	0.9 σ [MPa]
S 355	0,90	435,6	352,8

Buckling

Buckling analysis was not calculated.

Bill of material

Manufacturing operations

Name	Plates [mm]	Shape	Nr.	Welds [mm]	Length [mm]	Bolts	Nr.
CUT1				Double fillet: a = 5,0	339,5		
CUT2				Double fillet: a = 5,0	278,3		
CUT3				Double fillet: a = 5,0	339,5		

Welds

Type	Material	Throat thickness [mm]	Leg size [mm]	Length [mm]
Double fillet	S 355	5,0	7,1	957,4

Code settings

Item	Value	Unit	Reference
YM0	1,00	-	EN 1993-1-1: 6.1
YM1	1,00	-	EN 1993-1-1: 6.1
YM2	1,25	-	EN 1993-1-1: 6.1
YM3	1,25	-	EN 1993-1-8: 2.2
YC	1,50	-	EN 1992-1-1: 2.4.2.4
YInst	1,20	-	EN 1992-4: Table 4.1
Joint coefficient β_j	0,67	-	EN 1993-1-8: 6.2.5
Effective area - influence of mesh size	0,10	-	
Friction coefficient - concrete	0,25	-	EN 1993-1-8
Friction coefficient in slip-resistance	0,30	-	EN 1993-1-8 tab 3.7

Project:
Project no:
Author:

Item	Value	Unit	Reference
Limit plastic strain	0,05	-	EN 1993-1-5
Weld stress evaluation	Plastic redistribution		
Detailing	No		
Distance between bolts [d]	2,20	-	EN 1993-1-8: tab 3.3
Distance between bolts and edge [d]	1,20	-	EN 1993-1-8: tab 3.3
Concrete breakout resistance check	Both		EN 1992-4: 7.2.1.4 and 7.2.2.5
Use calculated a_b in bearing check.	Yes		EN 1993-1-8: tab 3.4
Cracked concrete	Yes		EN 1992-4
Local deformation check	No		CIDECT DG 1, 3 - 1.1
Local deformation limit	0,03	-	CIDECT DG 1, 3 - 1.1
Geometrical nonlinearity (GMNA)	Yes		Allow large deformations of hollow sections
Braced system	No		EN 1993-1-8: 5.2.2.5

9.8. Spoj gornjeg pojasa bočne rešetke i ispuna

Project:
Project no:
Author:

IDEA StatiCa®
Calculate yesterday's estimates

Material

Steel S 355

Project item Con N314

Design

Name Con N314
Description
Analysis Stress, strain/ loads in equilibrium

Beams and columns

Name	Cross-section	β - Direction [°]	γ - Pitch [°]	α - Rotation [°]	Offset ex [mm]	Offset ey [mm]	Offset ez [mm]	Forces in
B431	1 - CFRHS100X60X6(RHS100x60)	0,0	0,0	0,0	0	0	0	Position
B434	1 - CFRHS100X60X6(RHS100x60)	0,0	0,0	0,0	0	0	0	Position
B435	1 - CFRHS100X60X6(RHS100x60)	0,0	0,0	0,0	0	0	0	Position
B5202	2 - CFRHS200X100X10(RHS200x100)	0,0	0,0	0,0	0	0	0	Position

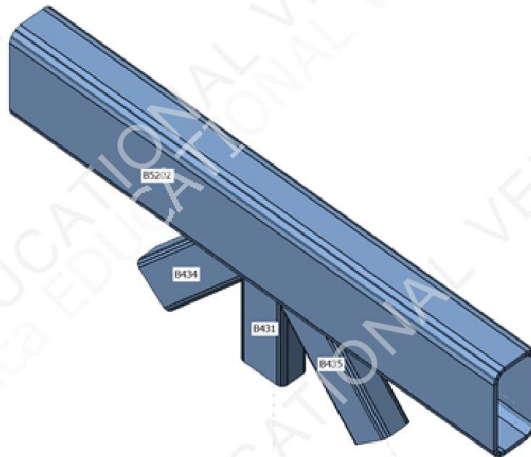

Project:
 Project no:
 Author:

Cross-sections

Name	Material
1 - CFRHS100X60X6(RHS100x60)	S 355
2 - CFRHS200X100X10(RHS200x100)	S 355

Cross-sections

Name	Material	Drawing
1 - CFRHS100X60X6(RHS100x60)	S 355	
2 - CFRHS200X100X10(RHS200x100)	S 355	

Project:
 Project no:
 Author:

Load effects (forces in equilibrium)

Name	Member	N [kN]	Vy [kN]	Vz [kN]	Mx [kNm]	My [kNm]	Mz [kNm]
ULS-Set(1)	B431	19,6	0,4	0,0	0,0	0,0	0,1
	B434	32,6	0,5	-0,1	-0,2	0,0	-0,4
	B435	-19,5	-0,4	-0,1	-0,1	0,0	-0,2
	B5202	677,5	0,2	-8,7	0,5	-7,5	0,6
ULS-Set(2)	B431	-32,2	0,1	0,0	-0,1	0,0	-0,1
	B434	-14,6	0,1	-0,1	-0,2	0,0	0,0
	B435	56,3	-0,2	-0,1	0,0	0,0	-0,1
	B5202	-1091,5	0,2	12,3	0,1	7,9	-0,2
ULS-Set(3)	B431	-18,7	-0,1	0,0	0,0	0,0	-0,1
	B434	-14,9	-0,1	-0,1	0,0	0,0	0,1
	B435	29,2	0,1	-0,1	0,0	0,0	0,1
	B5202	-653,4	0,0	7,9	-0,1	5,2	-0,3
ULS-Set(4)	B431	-0,2	-0,1	0,0	0,0	0,0	0,0
	B434	9,0	0,0	-0,1	0,1	0,0	0,0
	B435	4,7	0,1	-0,1	0,0	0,0	0,0
	B5202	-3,1	0,0	-0,9	0,0	-1,2	0,1
ULS-Set(5)	B431	18,8	0,5	0,0	0,0	0,0	0,1
	B434	45,5	0,6	-0,1	-0,3	0,0	-0,5
	B435	-10,8	-0,5	-0,1	-0,2	0,0	-0,3
	B5202	674,4	0,3	-9,8	0,7	-8,8	0,9
ULS-Set(6)	B431	-0,9	0,1	0,0	0,0	0,0	0,0
	B434	20,6	0,2	-0,1	-0,1	0,0	-0,1
	B435	12,2	-0,1	-0,1	0,0	0,0	-0,1
	B5202	-5,5	0,1	-1,9	0,2	-2,5	0,3
ULS-Set(7)	B431	-31,4	0,2	0,0	-0,1	0,0	0,0
	B434	-25,3	0,1	-0,1	-0,3	0,0	0,0
	B435	50,0	-0,2	-0,1	0,0	0,0	0,0
	B5202	-1087,5	0,2	13,6	0,1	9,1	-0,4
ULS-Set(8)	B431	10,9	0,1	0,0	0,1	0,0	0,0
	B434	34,6	0,3	-0,1	0,0	0,0	-0,2
	B435	-2,9	-0,1	-0,1	0,0	0,0	-0,2
	B5202	402,3	0,1	-6,8	0,3	-6,3	0,6
ULS-Set(9)	B431	19,2	0,4	0,0	0,0	0,0	0,1
	B434	37,4	0,5	-0,1	-0,3	0,0	-0,4
	B435	-16,2	-0,4	-0,1	-0,1	0,0	-0,3
	B5202	676,4	0,3	-9,2	0,6	-7,9	0,7
ULS-Set(10)	B431	-0,2	-0,1	0,0	0,0	0,0	0,0
	B434	9,0	0,0	-0,1	0,1	0,0	0,0
	B435	4,7	0,1	-0,1	0,0	0,0	0,0
	B5202	-2,5	0,0	-0,9	0,0	-1,2	0,1

Project:
 Project no:
 Author:

Check

Summary

Name	Value	Status
Analysis	100,0%	OK
Plates	0,0 < 5,0%	OK
Welds	98,0 < 100%	OK
Buckling	Not calculated	
GMNA	Calculated	

Plates

Name	Thickness [mm]	Loads	σ_{Ed} [MPa]	ϵ_{p1} [%]	σ_{CEd} [MPa]	Status
B431	6,0	ULS-Set(7)	264,5	0,0	0,0	OK
B434	6,0	ULS-Set(2)	282,6	0,0	0,0	OK
B435	6,0	ULS-Set(7)	260,2	0,0	0,0	OK
B5202	10,0	ULS-Set(7)	340,8	0,0	0,0	OK

Design data

Material	f_y [MPa]	ϵ_{lim} [%]
S 355	355,0	5,0

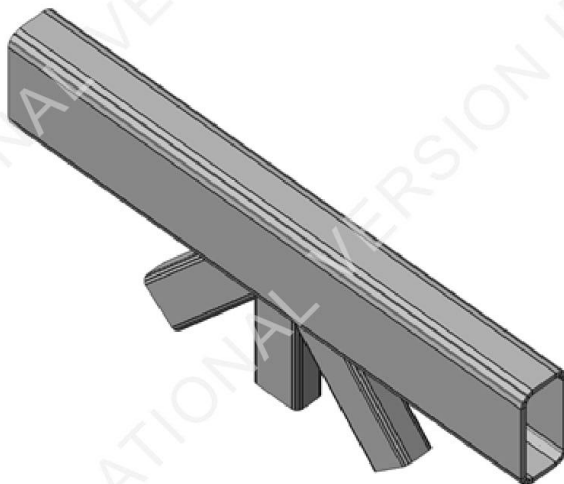

Overall check, ULS-Set(7)

Project:
 Project no:
 Author:

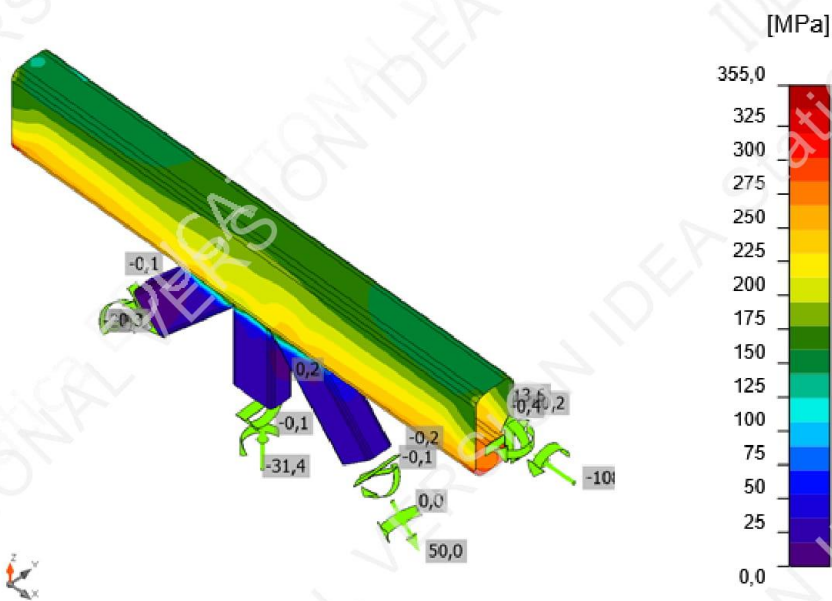
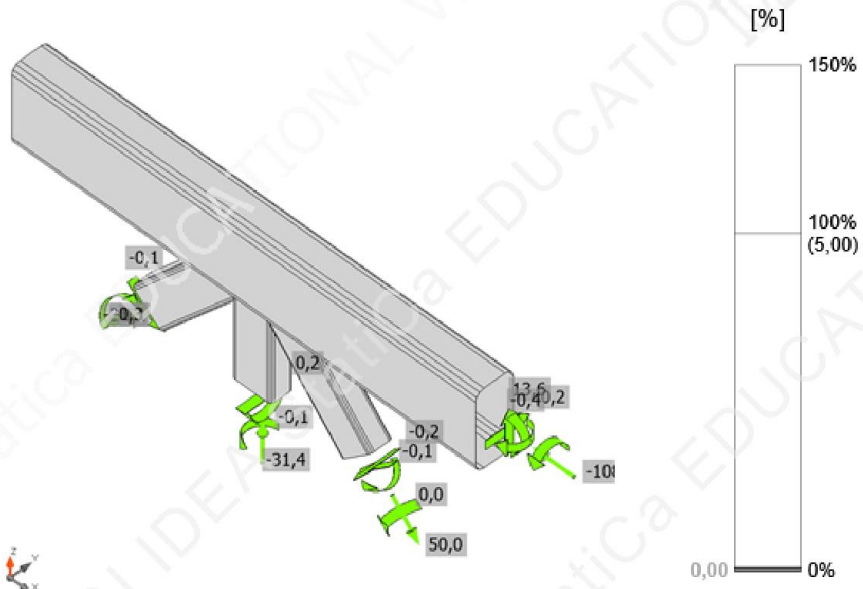

Project:
Project no:
Author:

Welds (Plastic redistribution)

Item	Edge	Throat th. [mm]	Length [mm]	Loads	$\sigma_{w,Ed}$ [MPa]	ϵ_{pl} [%]	σ_{\perp} [MPa]	τ_{\parallel} [MPa]	τ_{\perp} [MPa]	Ut [%]	Ut _c [%]	Status
B5202-arc 1	B434	▲4,0▲	339	ULS-Set(7)	344,3	0,0	-17,3	-197,6	-18,8	79,0	19,5	OK
B5202-arc 1	B431	▲4,0▲	279	ULS-Set(7)	427,0	0,1	-39,6	221,2	-106,3	98,0	19,8	OK
B5202-arc 12	B435	▲4,0▲	339	ULS-Set(7)	318,9	0,0	-11,8	-183,8	-8,5	73,2	20,6	OK
		▲4,0▲	339	ULS-Set(7)	315,6	0,0	-103,3	-141,5	-98,0	72,5	17,8	OK
		▲4,0▲	279	ULS-Set(2)	400,2	0,0	-146,7	200,1	78,7	91,9	20,1	OK
		▲4,0▲	339	ULS-Set(2)	363,9	0,0	-75,0	165,7	-121,7	83,6	18,8	OK

Design data

	β_w [-]	$\sigma_{w,Rd}$ [MPa]	0.9 σ [MPa]
S 355	0,90	435,6	352,8

Buckling

Buckling analysis was not calculated.

Bill of material

Manufacturing operations

Name	Plates [mm]	Shape	Nr.	Welds [mm]	Length [mm]	Bolts	Nr.
CUT1				Double fillet: a = 4,0	339,4		
CUT2				Double fillet: a = 4,0	279,2		
CUT3				Double fillet: a = 4,0	339,4		

Welds

Type	Material	Throat thickness [mm]	Leg size [mm]	Length [mm]
Double fillet	S 355	4,0	5,7	958,0

Code settings

Item	Value	Unit	Reference
YM0	1,00	-	EN 1993-1-1: 6.1
YM1	1,00	-	EN 1993-1-1: 6.1
YM2	1,25	-	EN 1993-1-1: 6.1
YM3	1,25	-	EN 1993-1-8: 2.2
YC	1,50	-	EN 1992-1-1: 2.4.2.4
YInst	1,20	-	EN 1992-4: Table 4.1
Joint coefficient β_j	0,67	-	EN 1993-1-8: 6.2.5
Effective area - influence of mesh size	0,10	-	
Friction coefficient - concrete	0,25	-	EN 1993-1-8
Friction coefficient in slip-resistance	0,30	-	EN 1993-1-8 tab 3.7

Project:
 Project no:
 Author:



Item	Value	Unit	Reference
Limit plastic strain	0,05	-	EN 1993-1-5
Weld stress evaluation	Plastic redistribution		
Detailing	No		
Distance between bolts [d]	2,20	-	EN 1993-1-8: tab 3.3
Distance between bolts and edge [d]	1,20	-	EN 1993-1-8: tab 3.3
Concrete breakout resistance check	Both		EN 1992-4: 7.2.1.4 and 7.2.2.5
Use calculated a_b in bearing check.	Yes		EN 1993-1-8: tab 3.4
Cracked concrete	Yes		EN 1992-4
Local deformation check	No		CIDECT DG 1, 3 - 1.1
Local deformation limit	0,03	-	CIDECT DG 1, 3 - 1.1
Geometrical nonlinearity (GMNA)	Yes		Allow large deformations of hollow sections
Braced system	No		EN 1993-1-8: 5.2.2.5

9.9. Spoj grede sa zidom

Project:
Project no:
Author:

IDEA StatiCa®
Calculate yesterday's estimates

Material

Steel S 355
Concrete C35/45

Project item Con N2179

Design

Name Con N2179
Description
Analysis Stress, strain/ loads in equilibrium

Beams and columns

Name	Cross-section	β - Direction [°]	γ - Pitch [°]	α - Rotation [°]	Offset ex [mm]	Offset ey [mm]	Offset ez [mm]	Forces in
B3973	1 - HEB160	0,0	0,0	0,0	0	0	0	Position

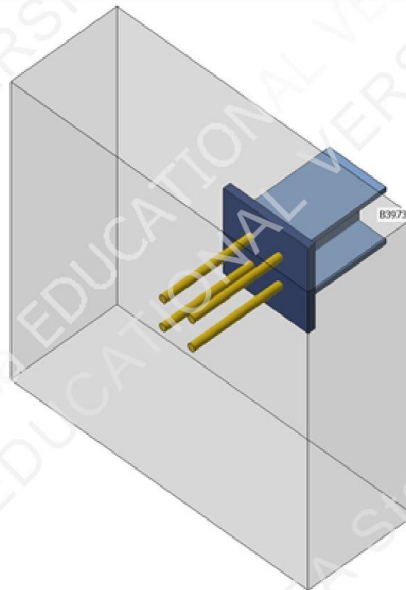

Cross-sections

Name	Material
1 - HEB160	S 355

Project:
Project no:
Author:

Cross-sections

Name	Material	Drawing
1 - HEB160	S 355	

Anchors

Name	Bolt assembly	Diameter [mm]	fu [MPa]	Gross area [mm ²]
M20 10.9	M20 10.9	20	1000,0	314

Load effects (forces in equilibrium)

Name	Member	N [kN]	Vy [kN]	Vz [kN]	Mx [kNm]	My [kNm]	Mz [kNm]
ULS-Set(1)	B3973	-114,0	0,0	-1,1	0,0	0,0	0,0
ULS-Set(2)	B3973	69,4	0,0	-0,8	0,0	0,0	0,0
ULS-Set(3)	B3973	65,7	0,0	-0,8	0,0	0,0	0,0
ULS-Set(4)	B3973	-110,3	0,0	-1,1	0,0	0,0	0,0
ULS-Set(5)	B3973	-3,1	0,0	-1,1	0,0	0,0	0,0
ULS-Set(6)	B3973	-2,3	0,0	-0,8	0,0	0,0	0,0
ULS-Set(7)	B3973	-110,2	0,0	-1,1	0,0	0,0	0,0
ULS-Set(8)	B3973	65,9	0,0	-0,8	0,0	0,0	0,0
ULS-Set(9)	B3973	-110,3	0,0	-1,1	0,0	0,0	0,0
ULS-Set(10)	B3973	-114,0	0,0	-1,1	0,0	0,0	0,0

Foundation block

Item	Value	Unit
CB 1		
Dimensions	840 x 840	mm
Depth	300	mm
Anchor	M20 10.9	
Anchoring length	250	mm
Shear force transfer	Anchors	

Project:
Project no:
Author:

Check

Summary

Name	Value	Status
Analysis	100,0%	OK
Plates	0,0 < 5,0%	OK
Anchors	93,1 < 100%	OK
Welds	20,3 < 100%	OK
Concrete block	4,2 < 100%	OK
Buckling	Not calculated	

Plates

Name	Thickness [mm]	Loads	σ_{Ed} [MPa]	ϵ_{pl} [%]	σ_{CEd} [MPa]	Status
B3973-bfl 1	13,0	ULS-Set(1)	53,1	0,0	0,0	OK
B3973-tfl 1	13,0	ULS-Set(1)	52,6	0,0	0,0	OK
B3973-w 1	8,0	ULS-Set(1)	60,0	0,0	0,0	OK
BP1	20,0	ULS-Set(1)	56,8	0,0	0,0	OK

Design data

Material	f_y [MPa]	ϵ_{lim} [%]
S 355	355,0	5,0

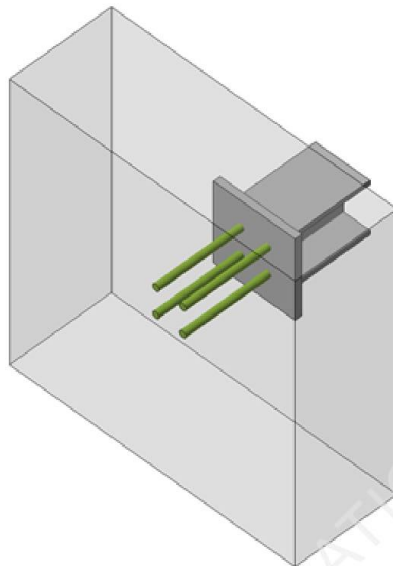

Overall check, ULS-Set(1)

Project:
Project no:
Author:

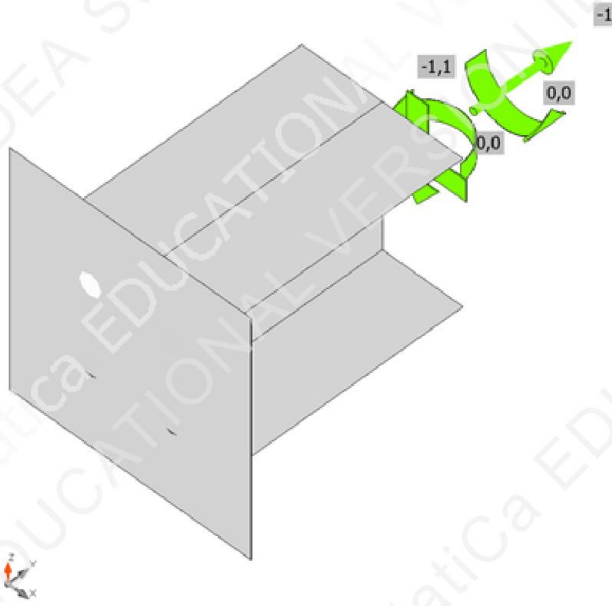

Strain check, ULS-Set(1)

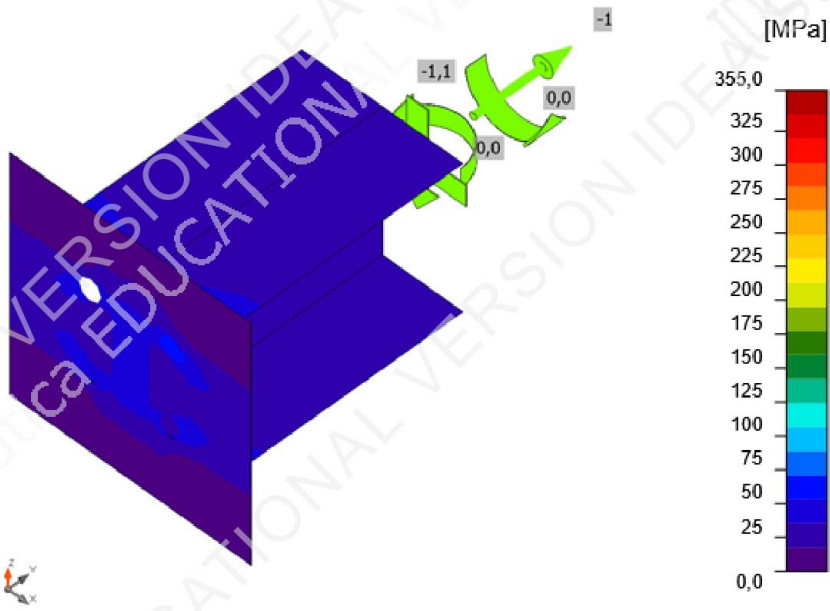

Equivalent stress, ULS-Set(1)

Project:
Project no:
Author:

Anchors

Shape	Item	Loads	N _{Ed} [kN]	V _{Ed} [kN]	N _{Rd,c} [kN]	V _{Rd,c} [kN]	V _{Rd,cp} [kN]	U _t [%]	U _s [%]	U _{ts} [%]	Status
	A1	ULS-Set(1)	28,7	0,2	122,5	39,8	245,0	93,1	2,8	90,3	OK
	A2	ULS-Set(1)	28,3	0,3	122,5	39,8	245,0	93,1	2,8	90,3	OK
	A3	ULS-Set(1)	28,6	0,3	122,5	-	245,0	93,1	0,4	89,9	OK
	A4	ULS-Set(1)	28,4	0,5	122,5	-	245,0	93,1	0,6	89,9	OK

Design data

Grade	N _{Rd,s} [kN]	V _{Rd,s} [kN]
M20 10.9 - 1	148,8	81,7

Welds (Plastic redistribution)

Item	Edge	Throat th. [mm]	Length [mm]	Loads	σ _{w,Ed} [MPa]	ε _{pI} [%]	σ _⊥ [MPa]	τ [MPa]	τ _⊥ [MPa]	U _t [%]	U _c [%]	Status
BP1	B3973-bfl 1	▲4,0▲	160	ULS-Set(1)	86,3	0,0	38,6	24,6	37,2	19,8	14,5	OK
		▲4,0▲	160	ULS-Set(2)	71,4	0,0	-27,9	-23,4	29,8	16,4	8,1	OK
BP1	B3973-tfl 1	▲4,0▲	160	ULS-Set(2)	70,4	0,0	-27,7	-22,9	-29,5	16,2	8,0	OK
		▲4,0▲	160	ULS-Set(1)	86,2	0,0	38,5	24,4	-37,2	19,8	14,3	OK
BP1	B3973-w 1	▲4,0▲	147	ULS-Set(1)	88,4	0,0	44,3	0,2	44,2	20,3	16,6	OK
		▲4,0▲	147	ULS-Set(1)	88,2	0,0	44,0	-0,9	-44,1	20,3	16,6	OK

Design data

	β _w [-]	σ _{w,Rd} [MPa]	0.9 σ [MPa]
S 355	0,90	435,6	352,8

Concrete block

Item	Loads	c [mm]	A _{eff} [mm ²]	σ [MPa]	k _j [-]	F _{jd} [MPa]	U _t [%]	Status
CB 1	ULS-Set(2)	35	41801	1,7	2,52	39,4	4,2	OK

Buckling

Buckling analysis was not calculated.

Bill of material

Manufacturing operations

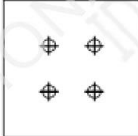
Name	Plates [mm]	Shape	Nr.	Welds [mm]	Length [mm]	Bolts	Nr.
BP1	P20,0x240,0-240,0 (S 355)		1	Double fillet: a = 4,0	467,0	M20 10.9	4

Project:
Project no:
Author:

Welds

Type	Material	Throat thickness [mm]	Leg size [mm]	Length [mm]
Double fillet	S 355	4,0	5,7	467,0

Anchors

Name	Length [mm]	Drill length [mm]	Count
M20 10.9	270	250	4

Code settings

Item	Value	Unit	Reference
Y _{M0}	1,00	-	EN 1993-1-1: 6.1
Y _{M1}	1,00	-	EN 1993-1-1: 6.1
Y _{M2}	1,25	-	EN 1993-1-1: 6.1
Y _{M3}	1,25	-	EN 1993-1-8: 2.2
Y _c	1,50	-	EN 1992-1-1: 2.4.2.4
Y _{inst}	1,20	-	EN 1992-4: Table 4.1
Joint coefficient β _j	0,67	-	EN 1993-1-8: 6.2.5
Effective area - influence of mesh size	0,10	-	
Friction coefficient - concrete	0,25	-	EN 1993-1-8
Friction coefficient in slip-resistance	0,30	-	EN 1993-1-8 tab 3.7
Limit plastic strain	0,05	-	EN 1993-1-5
Weld stress evaluation	Plastic redistribution		
Detailing	No		
Distance between bolts [d]	2,20	-	EN 1993-1-8: tab 3.3
Distance between bolts and edge [d]	1,20	-	EN 1993-1-8: tab 3.3
Concrete breakout resistance check	Both		EN 1992-4: 7.2.1.4 and 7.2.2.5
Use calculated a _b in bearing check.	Yes		EN 1993-1-8: tab 3.4
Cracked concrete	Yes		EN 1992-4
Local deformation check	No		CIDECT DG 1, 3 - 1.1
Local deformation limit	0,03	-	CIDECT DG 1, 3 - 1.1
Geometrical nonlinearity (GMNA)	Yes		Allow large deformations of hollow sections
Braced system	No		EN 1993-1-8: 5.2.2.5

9.10. Nastavak gornjeg pojasa glavne rešetke

Project:
Project no:
Author:



Material

Steel S 355

Project item Con N1015

Design

Name Con N1015
Description
Analysis Stress, strain/ loads in equilibrium

Beams and columns

Name	Cross-section	β - Direction [°]	γ - Pitch [°]	α - Rotation [°]	Offset ex [mm]	Offset ey [mm]	Offset ez [mm]	Forces in
B3048	3 - CFRHS200X100X10(RHS200x100)	0,0	0,0	0,0	0	0	0	Position
B3049	3 - CFRHS200X100X10(RHS200x100)	0,0	0,0	0,0	0	0	0	Position

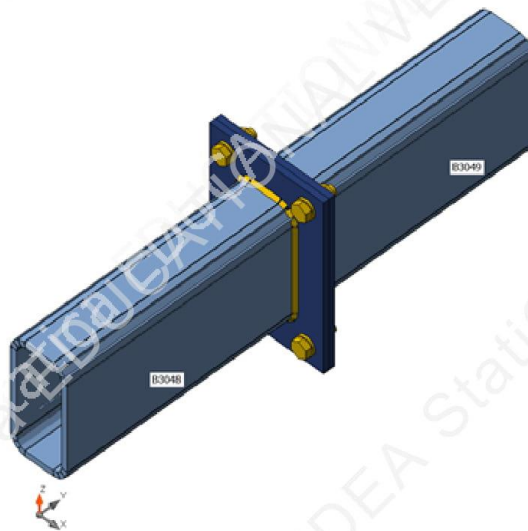

Cross-sections

Name	Material
3 - CFRHS200X100X10(RHS200x100)	S 355

Project:
Project no:
Author:

Cross-sections

Name	Material	Drawing
3 - CFRHS200X100X10(RHS200x100)	S 355	

Bolts

Name	Bolt assembly	Diameter [mm]	f_u [MPa]	Gross area [mm ²]
M16 10.9	M16 10.9	16	1000,0	201

Load effects (forces in equilibrium)

Name	Member	N [kN]	V _y [kN]	V _z [kN]	M _x [kNm]	M _y [kNm]	M _z [kNm]
ULS-Set(1)	B3048	149,6	0,2	-0,2	-0,2	0,9	-0,3
	B3049	-150,0	-0,1	-0,2	0,2	-0,9	-0,1
ULS-Set(2)	B3048	389,8	0,4	-0,1	-0,5	2,5	-0,4
	B3049	-389,3	-0,3	-0,3	0,6	-2,5	-0,4
ULS-Set(3)	B3048	416,2	0,4	0,2	-0,5	2,8	-0,4
	B3049	-416,5	-0,2	-0,1	0,6	-2,8	-0,2
ULS-Set(4)	B3048	121,2	0,3	-0,4	-0,2	0,6	-0,3
	B3049	-121,0	-0,2	-0,4	0,2	-0,6	-0,3
ULS-Set(5)	B3048	291,9	0,4	-0,2	-0,4	1,8	-0,5
	B3049	-291,6	-0,3	-0,4	0,5	-1,7	-0,4
ULS-Set(6)	B3048	123,2	0,2	-0,4	-0,2	0,6	-0,2
	B3049	-122,8	-0,2	-0,5	0,2	-0,6	-0,3
ULS-Set(7)	B3048	414,7	0,5	0,1	-0,6	2,8	-0,6
	B3049	-414,9	-0,3	-0,1	0,6	-2,7	-0,4
ULS-Set(8)	B3048	119,5	0,3	-0,4	-0,2	0,6	-0,3
	B3049	-119,3	-0,2	-0,4	0,2	-0,6	-0,3
ULS-Set(9)	B3048	388,0	0,4	-0,1	-0,5	2,5	-0,4
	B3049	-387,5	-0,3	-0,3	0,6	-2,4	-0,4
ULS-Set(10)	B3048	388,2	0,5	-0,1	-0,6	2,4	-0,6
	B3049	-387,6	-0,4	-0,4	0,6	-2,4	-0,6

Project:
 Project no:
 Author:

Check

Summary

Name	Value	Status
Analysis	100,0%	OK
Plates	0,0 < 5,0%	OK
Bolts	2,2 < 100%	OK
Welds	79,3 < 100%	OK
Buckling	Not calculated	
GMNA	Calculated	

Plates

Name	Thickness [mm]	Loads	σ_{Ed} [MPa]	ϵ_{pl} [%]	σ_{CEd} [MPa]	Status
B3048	10,0	ULS-Set(7)	117,6	0,0	0,0	OK
B3049	10,0	ULS-Set(7)	113,9	0,0	0,0	OK
PP1a	10,0	ULS-Set(7)	12,6	0,0	16,6	OK
PP1b	10,0	ULS-Set(3)	12,3	0,0	16,6	OK

Design data

Material	f_y [MPa]	ϵ_{lim} [%]
S 355	355,0	5,0

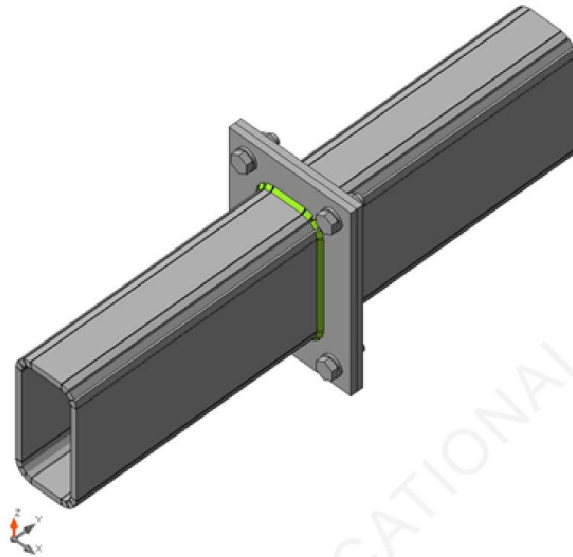

Overall check, ULS-Set(7)

Project:
 Project no:
 Author:

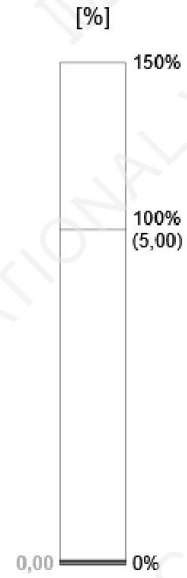
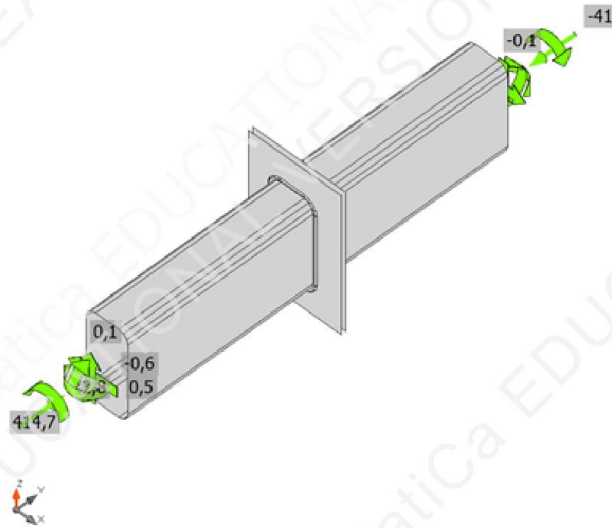

Strain check, ULS-Set(7)

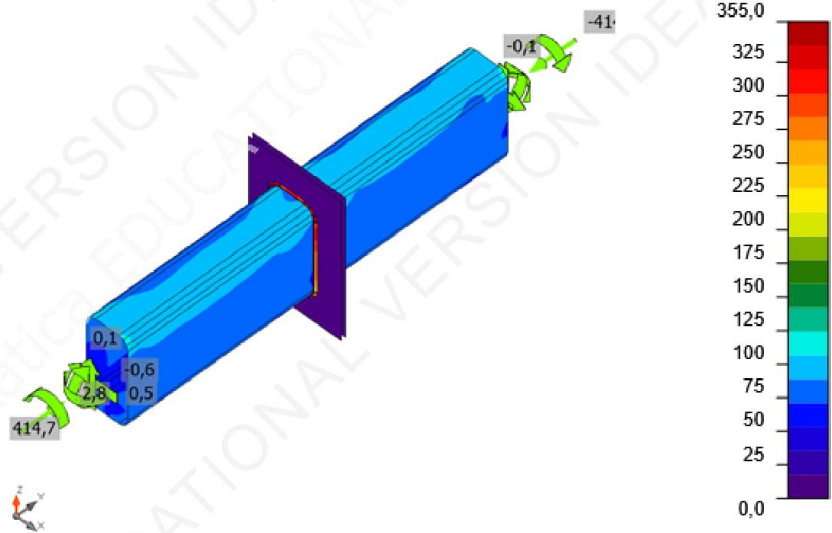

Equivalent stress, ULS-Set(7)

Project:
Project no:
Author:

Bolts

	Name	Loads	$F_{t,Ed}$ [kN]	V [kN]	U_{t_t} [%]	$F_{b,Rd}$ [kN]	U_{t_s} [%]	$U_{t_{ts}}$ [%]	Status
	B1	ULS-Set(10)	0,2	1,2	0,2	96,1	1,9	2,1	OK
	B2	ULS-Set(10)	0,2	1,3	0,2	103,4	2,1	2,2	OK
	B3	ULS-Set(9)	0,2	1,0	0,2	100,5	1,7	1,8	OK
	B4	ULS-Set(10)	0,2	1,1	0,2	111,4	1,8	1,9	OK

Design data

Name	$F_{t,Rd}$ [kN]	$B_{p,Rd}$ [kN]	$F_{v,Rd}$ [kN]
M16 10.9 - 1	113,0	209,0	62,8

Welds (Plastic redistribution)

Item	Edge	Throat th. [mm]	Length [mm]	Loads	$\sigma_{w,Ed}$ [MPa]	ϵ_{pl} [%]	σ_{\perp} [MPa]	τ_{\parallel} [MPa]	τ_{\perp} [MPa]	U_t [%]	U_{t_c} [%]	Status
PP1a	B3048	4,0	524	ULS-Set(7)	343,4	0,0	-195,4	24,1	161,2	78,8	63,7	OK
PP1b	B3049	4,0	524	ULS-Set(7)	345,4	0,0	-198,5	14,4	162,5	79,3	63,7	OK

Design data



	β_w [-]	$\sigma_{w,Rd}$ [MPa]	0.9σ [MPa]
S 355	0,90	435,6	352,8

Buckling

Buckling analysis was not calculated.

Bill of material

Manufacturing operations

Name	Plates [mm]	Shape	Nr.	Welds [mm]	Length [mm]	Bolts	Nr.
PP1	P10,0x200,0-300,0 (S 355)		1	Fillet: a = 4,0	1048,5	M16 10.9	4
	P10,0x200,0-300,0 (S 355)		1				

Project:
Project no:
Author:



Welds

Type	Material	Throat thickness [mm]	Leg size [mm]	Length [mm]
Fillet	S 355	4,0	5,7	1048,5

Bolts

Name	Grip length [mm]	Count
M16 10.9	20	4

Code settings

Item	Value	Unit	Reference
YM0	1,00	-	EN 1993-1-1: 6.1
YM1	1,00	-	EN 1993-1-1: 6.1
YM2	1,25	-	EN 1993-1-1: 6.1
YM3	1,25	-	EN 1993-1-8: 2.2
YC	1,50	-	EN 1992-1-1: 2.4.2.4
YInst	1,20	-	EN 1992-4: Table 4.1
Joint coefficient β_j	0,67	-	EN 1993-1-8: 6.2.5
Effective area - influence of mesh size	0,10	-	
Friction coefficient - concrete	0,25	-	EN 1993-1-8
Friction coefficient in slip-resistance	0,30	-	EN 1993-1-8 tab 3.7
Limit plastic strain	0,05	-	EN 1993-1-5
Weld stress evaluation	Plastic redistribution		
Detailing	No		
Distance between bolts [d]	2,20	-	EN 1993-1-8: tab 3.3
Distance between bolts and edge [d]	1,20	-	EN 1993-1-8: tab 3.3
Concrete breakout resistance check	Both		EN 1992-4: 7.2.1.4 and 7.2.2.5
Use calculated a_b in bearing check.	Yes		EN 1993-1-8: tab 3.4
Cracked concrete	Yes		EN 1992-4
Local deformation check	No		CIDECT DG 1, 3 - 1.1
Local deformation limit	0,03	-	CIDECT DG 1, 3 - 1.1
Geometrical nonlinearity (GMNA)	Yes		Allow large deformations of hollow sections
Braced system	No		EN 1993-1-8: 5.2.2.5

9.11. Nastavak donjeg pojasa glavne rešetke

Project:
Project no:
Author:



Material

Steel S 355

Project item Con N1014

Design

Name Con N1014
Description
Analysis Stress, strain/ loads in equilibrium

Beams and columns

Name	Cross-section	β - Direction [°]	γ - Pitch [°]	α - Rotation [°]	Offset ex [mm]	Offset ey [mm]	Offset ez [mm]	Forces in
B5098	2 - CFRHS200X100X12.5(RHS200x100)	0,0	0,0	0,0	0	0	0	Position
B5099	2 - CFRHS200X100X12.5(RHS200x100)	0,0	0,0	0,0	0	0	0	Position

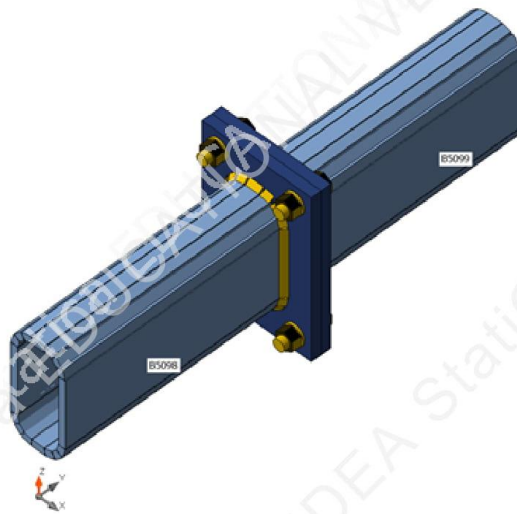

Cross-sections

Name	Material
2 - CFRHS200X100X12.5(RHS200x100)	S 355

Project:
Project no:
Author:

Cross-sections

Name	Material	Drawing
2 - CFRHS200X100X12.5(RHS200x100)	S 355	

Bolts

Name	Bolt assembly	Diameter [mm]	fu [MPa]	Gross area [mm ²]
M20 10.9	M20 10.9	20	1000,0	314

Load effects (forces in equilibrium)

Name	Member	N [kN]	Vy [kN]	Vz [kN]	Mx [kNm]	My [kNm]	Mz [kNm]
ULS-Set(1)	B5098	-88,6	0,0	-0,3	-0,3	0,9	0,1
	B5099	129,5	0,0	-0,3	0,2	-0,9	0,0
ULS-Set(2)	B5098	-305,2	-0,1	-0,3	-0,9	2,5	0,3
	B5099	456,3	0,1	-0,6	0,6	-2,5	0,0
ULS-Set(3)	B5098	-274,6	-0,1	0,0	-0,9	2,8	0,2
	B5099	425,1	0,1	-0,3	0,6	-2,8	0,1
ULS-Set(4)	B5098	-103,8	0,0	-0,5	-0,3	0,6	0,1
	B5099	140,6	0,0	-0,5	0,2	-0,6	0,0
ULS-Set(5)	B5098	-231,5	-0,1	-0,4	-0,7	1,7	0,2
	B5099	329,6	0,1	-0,6	0,4	-1,7	0,0
ULS-Set(6)	B5098	-119,2	0,0	-0,6	-0,3	0,5	0,1
	B5099	160,7	0,0	-0,6	0,2	-0,5	0,0
ULS-Set(7)	B5098	-283,3	-0,1	-0,1	-0,9	2,8	0,2
	B5099	436,4	0,1	-0,3	0,6	-2,8	0,1
ULS-Set(8)	B5098	-102,9	0,0	-0,5	-0,3	0,6	0,1
	B5099	138,3	0,0	-0,5	0,2	-0,6	0,0
ULS-Set(9)	B5098	-304,1	-0,1	-0,3	-0,9	2,4	0,3
	B5099	453,7	0,1	-0,6	0,6	-2,4	0,0
ULS-Set(10)	B5098	-313,7	-0,1	-0,4	-0,9	2,4	0,3
	B5099	467,3	0,1	-0,6	0,6	-2,4	0,0

Project:
 Project no:
 Author:

Check

Summary

Name	Value	Status
Analysis	100,0%	OK
Plates	0,3 < 5,0%	OK
Bolts	94,6 < 100%	OK
Welds	98,7 < 100%	OK
Buckling	Not calculated	
GMNA	Calculated	

Plates

Name	Thickness [mm]	Loads	σ_{Ed} [MPa]	ϵ_{pl} [%]	σ_{CEd} [MPa]	Status
B5098	12,5	ULS-Set(10)	259,3	0,0	0,0	OK
B5099	12,5	ULS-Set(10)	259,6	0,0	0,0	OK
PP1a	18,0	ULS-Set(10)	355,6	0,3	152,3	OK
PP1b	18,0	ULS-Set(10)	355,6	0,3	152,3	OK

Design data

Material	f_y [MPa]	ϵ_{lim} [%]
S 355	355,0	5,0

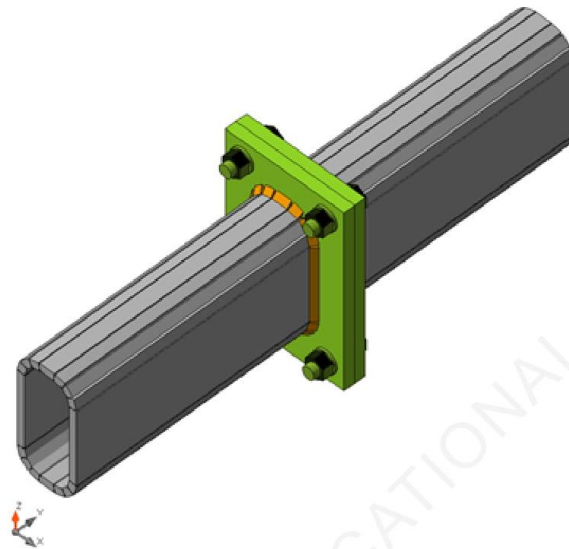

Overall check, ULS-Set(10)

Project:
 Project no:
 Author:

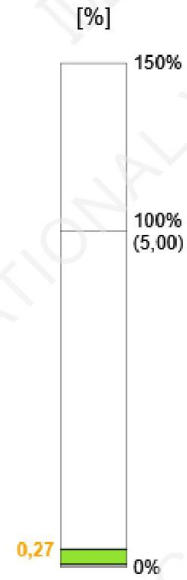
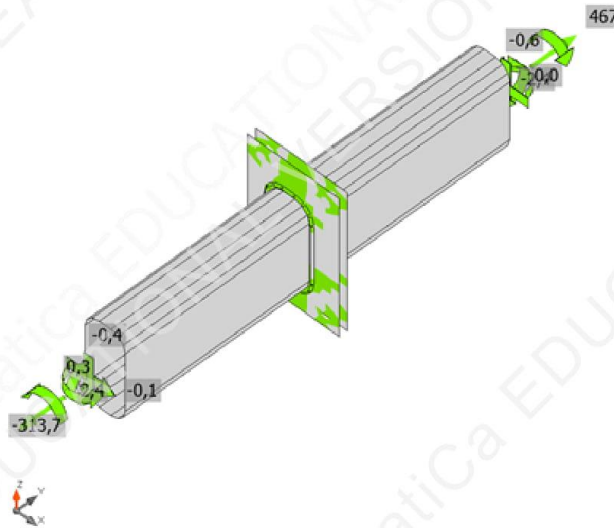

Strain check, ULS-Set(10)

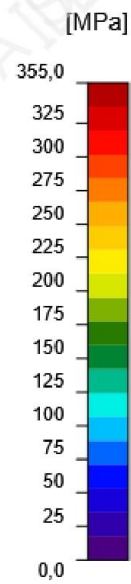
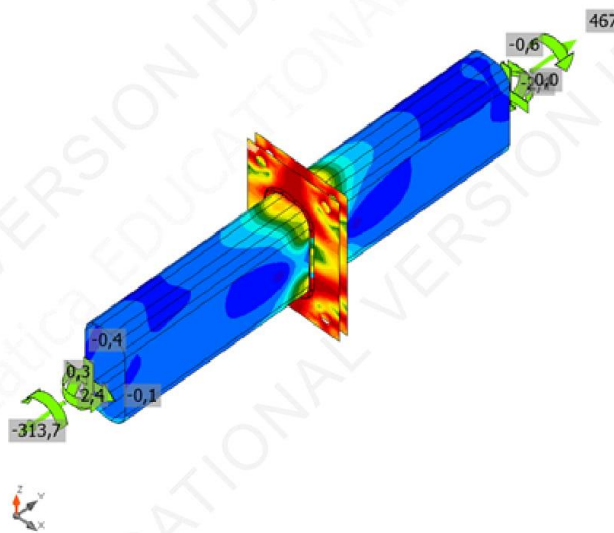

Equivalent stress, ULS-Set(10)

Project:
Project no:
Author:

Bolts

	Name	Loads	$F_{t,Ed}$ [kN]	V [kN]	U_{t_t} [%]	$F_{b,Rd}$ [kN]	U_{t_s} [%]	$U_{t_{ts}}$ [%]	Status
	B1	ULS-Set(10)	164,0	1,0	93,0	180,9	1,0	67,4	OK
	B2	ULS-Set(10)	164,0	1,2	93,0	218,1	1,2	67,6	OK
	B3	ULS-Set(10)	166,9	1,0	94,6	171,7	1,0	68,6	OK
	B4	ULS-Set(10)	166,9	1,1	94,6	198,7	1,2	68,8	OK

Design data

Name	$F_{t,Rd}$ [kN]	$B_{p,Rd}$ [kN]	$F_{v,Rd}$ [kN]
M20 10.9 - 1	176,4	445,8	98,0

Welds (Plastic redistribution)

Item	Edge	Throat th. [mm]	Length [mm]	Loads	$\sigma_{w,Ed}$ [MPa]	ϵ_{pl} [%]	σ_{\perp} [MPa]	τ_{\parallel} [MPa]	τ_{\perp} [MPa]	U_t [%]	U_{t_c} [%]	Status
PP1a	B5099	▲6,0	494	ULS-Set(10)	429,8	1,7	346,4	42,8	-140,5	98,7	75,0	OK
PP1b	B5098	▲6,0	494	ULS-Set(10)	429,0	1,3	327,2	83,8	-136,6	98,5	75,0	OK

Design data



	β_w [-]	$\sigma_{w,Rd}$ [MPa]	0.9σ [MPa]
S 355	0,90	435,6	352,8

Buckling

Buckling analysis was not calculated.

Bill of material

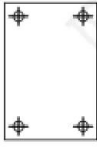
Manufacturing operations

Name	Plates [mm]	Shape	Nr.	Welds [mm]	Length [mm]	Bolts	Nr.
PP1	P18,0x200,0-300,0 (S 355)		1	Fillet: a = 6,0	988,2	M20 10.9	4
	P18,0x200,0-300,0 (S 355)		1				

Project:
Project no:
Author:

Welds

Type	Material	Throat thickness [mm]	Leg size [mm]	Length [mm]
Filet	S 355	6,0	8,5	988,2

Bolts

Name	Grip length [mm]	Count
M20 10.9	36	4

Code settings

Item	Value	Unit	Reference
YM0	1,00	-	EN 1993-1-1: 6.1
YM1	1,00	-	EN 1993-1-1: 6.1
YM2	1,25	-	EN 1993-1-1: 6.1
YM3	1,25	-	EN 1993-1-8: 2.2
YC	1,50	-	EN 1992-1-1: 2.4.2.4
YInst	1,20	-	EN 1992-4: Table 4.1
Joint coefficient β_j	0,67	-	EN 1993-1-8: 6.2.5
Effective area - influence of mesh size	0,10	-	
Friction coefficient - concrete	0,25	-	EN 1993-1-8
Friction coefficient in slip-resistance	0,30	-	EN 1993-1-8 tab 3.7
Limit plastic strain	0,05	-	EN 1993-1-5
Weld stress evaluation	Plastic redistribution		
Detailing	No		
Distance between bolts [d]	2,20	-	EN 1993-1-8: tab 3.3
Distance between bolts and edge [d]	1,20	-	EN 1993-1-8: tab 3.3
Concrete breakout resistance check	Both		EN 1992-4: 7.2.1.4 and 7.2.2.5
Use calculated c_b in bearing check.	Yes		EN 1993-1-8: tab 3.4
Cracked concrete	Yes		EN 1992-4
Local deformation check	No		CIDECT DG 1, 3 - 1.1
Local deformation limit	0,03	-	CIDECT DG 1, 3 - 1.1
Geometrical nonlinearity (GMNA)	Yes		Allow large deformations of hollow sections
Braced system	No		EN 1993-1-8: 5.2.2.5

9.12. Nastavak ispuna glavne rešetke

Project:
Project no:
Author:



Material

Steel S 355

Project item - Nastavak ispune glavne resetke

Design

Name - Nastavak ispune glavne resetke
Description
Analysis Stress, strain/ loads in equilibrium

Beams and columns

Name	Cross-section	β - Direction [°]	γ - Pitch [°]	α - Rotation [°]	Offset ex [mm]	Offset ey [mm]	Offset ez [mm]	Forces in
B1	3 - RHSCF140/80/6.0	0,0	0,0	0,0	0	0	0	Node
B2	3 - RHSCF140/80/6.0	180,0	0,0	0,0	0	0	0	Node

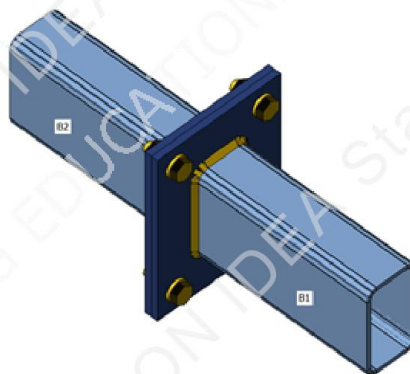

Cross-sections

Name	Material
3 - RHSCF140/80/6.0	S 355

Project:
Project no:
Author:

Cross-sections

Name	Material	Drawing
3 - RHSCF140/80/6.0	S 355	

Bolts

Name	Bolt assembly	Diameter [mm]	f_u [MPa]	Gross area [mm ²]
M16 10.9	M16 10.9	16	1000,0	201

Load effects (forces in equilibrium)

Name	Member	N [kN]	V _y [kN]	V _z [kN]	M _x [kNm]	M _y [kNm]	M _z [kNm]
LE1	B1	103,1	0,0	-0,3	0,0	0,0	-0,1
	B2	-103,1	0,0	0,3	0,0	0,0	0,1

Check

Summary

Name	Value	Status
Analysis	100,0%	OK
Plates	0,1 < 5,0%	OK
Bolts	54,6 < 100%	OK
Welds	97,5 < 100%	OK
Buckling	Not calculated	
GMNA	Calculated	

Plates

Name	Thickness [mm]	Loads	σ_{Ed} [MPa]	ϵ_{pl} [%]	σ_{cEd} [MPa]	Status
B1	6,0	LE1	274,7	0,0	0,0	OK
B2	6,0	LE1	274,7	0,0	0,0	OK
PP1a	10,0	LE1	355,2	0,1	44,3	OK
PP1b	10,0	LE1	355,2	0,1	44,3	OK

Project:
 Project no:
 Author:

Design data

Material	f_y [MPa]	ϵ_{lim} [%]
S 355	355,0	5,0

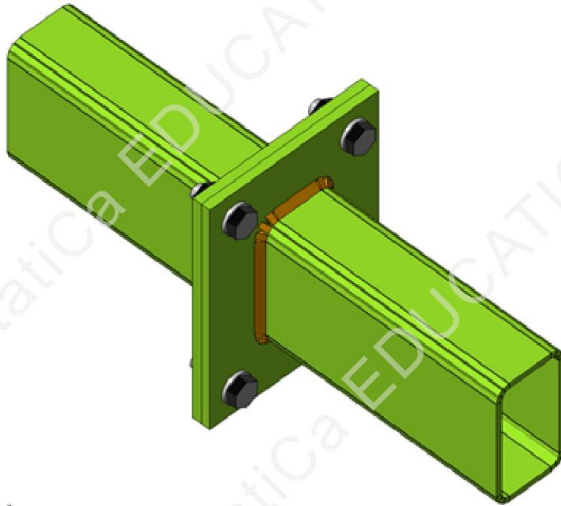

Overall check, LE1

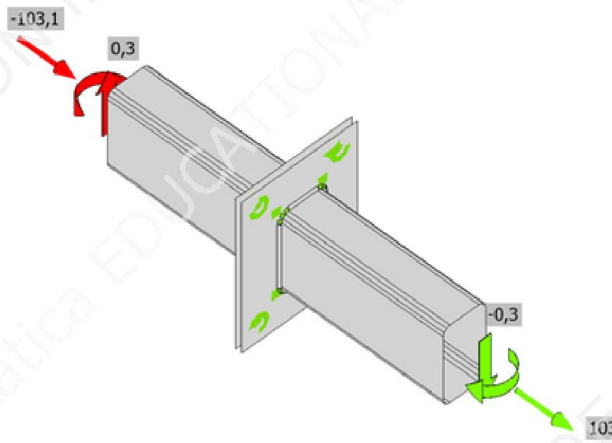

Strain check, LE1

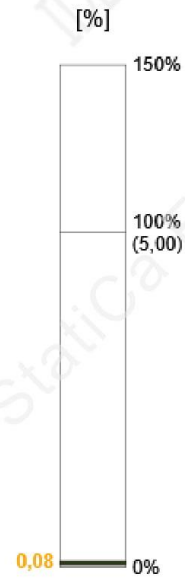

Project:
Project no:
Author:

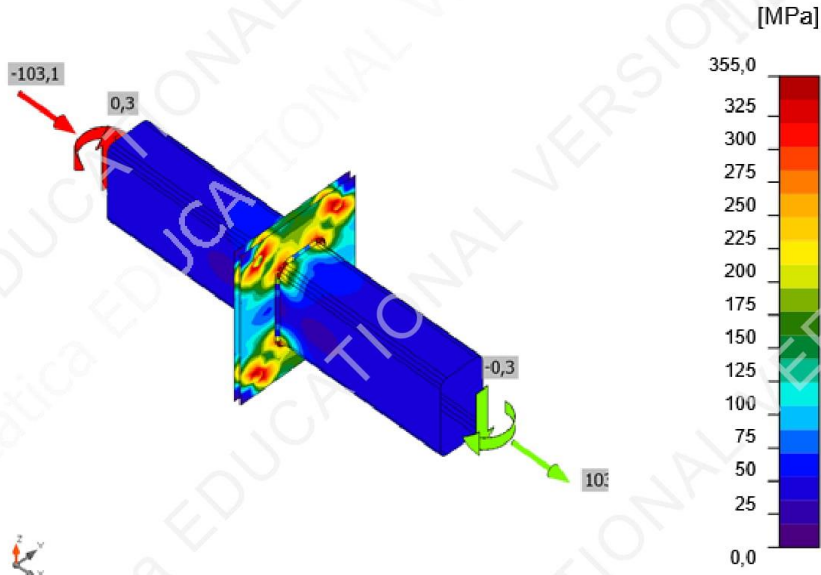

Equivalent stress, LE1

Bolts

	Name	Loads	$F_{t,Ed}$ [kN]	V [kN]	U_{t_t} [%]	$F_{b,Rd}$ [kN]	U_{t_s} [%]	$U_{t_{ts}}$ [%]	Status
	B1	LE1	61,7	0,1	54,6	87,4	0,1	39,1	OK
	B2	LE1	60,5	0,1	53,5	87,3	0,1	38,3	OK
	B3	LE1	61,7	0,1	54,6	87,4	0,1	39,1	OK
	B4	LE1	60,4	0,1	53,4	87,3	0,1	38,3	OK

Design data

Name	$F_{t,Rd}$ [kN]	$B_{p,Rd}$ [kN]	$F_{v,Rd}$ [kN]
M16 10.9 - 1	113,0	209,0	62,8

Welds (Plastic redistribution)

Item	Edge	Throat th. [mm]	Length [mm]	Loads	$\sigma_{w,Ed}$ [MPa]	ϵ_{PI} [%]	σ_{\perp} [MPa]	τ_{\parallel} [MPa]	τ_{\perp} [MPa]	U_t [%]	U_{t_c} [%]	Status
PP1a	B1	5,0	395	LE1	410,5	0,0	344,1	-42,2	-122,1	97,5	36,5	OK
PP1b	B2	5,0	395	LE1	410,0	0,0	344,1	41,7	-121,7	97,5	36,4	OK

Design data

	β_w [-]	$\sigma_{w,Rd}$ [MPa]	0.9σ [MPa]
S 355	0,90	435,6	352,8



Project:
Project no:
Author:

Buckling

Buckling analysis was not calculated.

Bill of material

Manufacturing operations

Name	Plates [mm]	Shape	Nr.	Welds [mm]	Length [mm]	Bolts	Nr.
PP1	P10,0x200,0-260,0 (S 355)		1	Fillet: a = 5,0	789,1	M16 10.9	4
	P10,0x200,0-260,0 (S 355)		1				

Welds

Type	Material	Throat thickness [mm]	Leg size [mm]	Length [mm]
Fillet	S 355	5,0	7,1	789,1

Bolts

Name	Grip length [mm]	Count
M16 10.9	20	4

Code settings

Item	Value	Unit	Reference
YM0	1,00	-	EN 1993-1-1: 6.1
YM1	1,00	-	EN 1993-1-1: 6.1
YM2	1,25	-	EN 1993-1-1: 6.1
YM3	1,25	-	EN 1993-1-8: 2.2
YC	1,50	-	EN 1992-1-1: 2.4.2.4
YInst	1,20	-	EN 1992-4: Table 4.1
Joint coefficient β_j	0,67	-	EN 1993-1-8: 6.2.5
Effective area - influence of mesh size	0,10	-	
Friction coefficient - concrete	0,25	-	EN 1993-1-8
Friction coefficient in slip-resistance	0,30	-	EN 1993-1-8 tab 3.7
Limit plastic strain	0,05	-	EN 1993-1-5
Weld stress evaluation	Plastic redistribution		
Detailing	No		

Project:
Project no:
Author:



Item	Value	Unit	Reference
Distance between bolts [d]	2,20	-	EN 1993-1-8: tab 3.3
Distance between bolts and edge [d]	1,20	-	EN 1993-1-8: tab 3.3
Concrete breakout resistance check	Both		EN 1992-4: 7.2.1.4 and 7.2.2.5
Use calculated ab in bearing check.	Yes		EN 1993-1-8: tab 3.4
Cracked concrete	Yes		EN 1992-4
Local deformation check	No		CIDECT DG 1, 3 - 1.1
Local deformation limit	0,03	-	CIDECT DG 1, 3 - 1.1
Geometrical nonlinearity (GMNA)	Yes		Allow large deformations of hollow sections
Braced system	No		EN 1993-1-8: 5.2.2.5

9.13. Spoj gornjeg pojasa glavne rešetke s ispunama

Project:
Project no:
Author:



Material

Steel S 355

Project item Con N1017

Design

Name Con N1017
Description
Analysis Stress, strain/ loads in equilibrium

Beams and columns

Name	Cross-section	β - Direction [°]	γ - Pitch [°]	α - Rotation [°]	Offset ex [mm]	Offset ey [mm]	Offset ez [mm]	Forces in
B1146	1 - CFRHS140X80X6(RHS140x80)	0,0	0,0	90,0	0	0	0	Position
B1165	1 - CFRHS140X80X6(RHS140x80)	0,0	0,0	0,0	0	0	0	Position
B1166	1 - CFRHS140X80X6(RHS140x80)	0,0	0,0	0,0	0	0	0	Position
B3048	3 - CFRHS200X100X10(RHS200x100)	0,0	0,0	0,0	0	0	0	Position



Project:
 Project no:
 Author:

Cross-sections

Name	Material
1 - CFRHS140X80X6(RHS140x80)	S 355
3 - CFRHS200X100X10(RHS200x100)	S 355

Cross-sections

Name	Material	Drawing
1 - CFRHS140X80X6(RHS140x80)	S 355	
3 - CFRHS200X100X10(RHS200x100)	S 355	

Project:
 Project no:
 Author:

Load effects (forces in equilibrium)

Name	Member	N [kN]	Vy [kN]	Vz [kN]	Mx [kNm]	My [kNm]	Mz [kNm]
ULS-Set(1)	B1146	-3,3	0,0	0,0	0,2	0,0	0,2
	B1165	-90,4	0,0	-0,3	0,0	0,0	0,1
	B1166	-116,9	-0,1	-0,3	0,2	0,0	0,2
	B3048	-399,6	-0,3	-1,6	0,5	-0,4	-0,4
	B3048	0,0	0,0	0,0	0,0	0,0	0,0
ULS-Set(2)	B1146	-1,4	0,0	0,0	0,1	0,0	0,1
	B1165	-39,7	0,0	-0,2	0,0	0,0	0,0
	B1166	-49,2	0,0	-0,2	0,1	0,0	0,1
	B3048	-160,9	-0,2	-0,6	0,3	-0,6	-0,3
	B3048	0,0	0,0	0,0	0,0	0,0	0,0
ULS-Set(3)	B1146	-2,4	0,0	0,0	0,1	0,0	0,1
	B1165	-37,7	0,0	-0,2	0,0	0,0	0,0
	B1166	-51,0	-0,1	-0,2	0,1	0,0	0,1
	B3048	-222,1	-0,1	-1,1	0,3	-0,1	-0,2
	B3048	0,0	0,0	0,0	0,0	0,0	0,0
ULS-Set(4)	B1146	-2,2	0,0	0,0	0,2	0,0	0,2
	B1165	-94,5	0,0	-0,3	0,0	0,0	0,0
	B1166	-116,2	-0,1	-0,3	0,2	0,0	0,2
	B3048	-330,4	-0,4	-1,1	0,5	-1,0	-0,6
	B3048	0,0	0,0	0,0	0,0	0,0	0,0
ULS-Set(5)	B1146	-2,5	0,0	0,0	0,1	0,0	0,2
	B1165	-66,0	0,0	-0,3	0,0	0,0	0,0
	B1166	-83,6	-0,1	-0,3	0,1	0,0	0,1
	B3048	-291,9	-0,4	-1,1	0,4	-0,7	-0,5
	B3048	0,0	0,0	0,0	0,0	0,0	0,0
ULS-Set(6)	B1146	-2,5	0,0	0,0	0,2	0,0	0,2
	B1165	-101,0	0,0	-0,3	0,0	0,0	0,1
	B1166	-127,3	-0,1	-0,3	0,2	0,0	0,2
	B3048	-388,0	-0,4	-1,3	0,5	-1,0	-0,5
	B3048	0,0	0,0	0,0	0,0	0,0	0,0
ULS-Set(7)	B1146	-1,6	0,0	0,0	0,0	0,0	0,1
	B1165	-24,8	0,0	-0,2	0,0	0,0	0,0
	B1166	-30,4	0,0	-0,2	0,1	0,0	0,0
	B3048	-121,2	-0,3	-0,6	0,2	-0,3	-0,3
	B3048	0,0	0,0	0,0	0,0	0,0	0,0
ULS-Set(8)	B1146	-3,0	0,0	0,0	0,2	0,0	0,2
	B1165	-102,0	0,0	-0,3	0,0	0,0	0,0
	B1166	-129,5	-0,1	-0,3	0,2	0,0	0,2
	B3048	-414,7	-0,5	-1,5	0,6	-0,7	-0,6
	B3048	0,0	0,0	0,0	0,0	0,0	0,0
ULS-Set(9)	B1146	-2,4	0,0	0,0	0,2	0,0	0,2

Project:
Project no:
Author:

Name	Member	N [kN]	Vy [kN]	Vz [kN]	Mx [kNm]	My [kNm]	Mz [kNm]
	B1165	-102,6	0,0	-0,3	0,0	0,0	0,0
	B1166	-128,3	-0,1	-0,3	0,2	0,0	0,2
	B3048	-386,6	-0,5	-1,2	0,6	-1,1	-0,7
	B3048	0,0	0,0	0,0	0,0	0,0	0,0
ULS-Set(10)	B1146	-2,0	0,0	0,0	0,0	0,0	0,1
	B1165	-27,8	0,0	-0,2	0,0	0,0	0,0
	B1166	-35,8	0,0	-0,2	0,1	0,0	0,0
	B3048	-151,3	-0,2	-0,8	0,2	-0,1	-0,3
	B3048	0,0	0,0	0,0	0,0	0,0	0,0

Check

Summary

Name	Value	Status
Analysis	100,0%	OK
Plates	0,0 < 5,0%	OK
Welds	98,1 < 100%	OK
Buckling	Not calculated	
GMNA	Calculated	

Plates

Name	Thickness [mm]	Loads	σ_{Ed} [MPa]	ϵ_{pl} [%]	σ_{CEd} [MPa]	Status
B1146	6,0	ULS-Set(8)	69,3	0,0	0,0	OK
B1165	6,0	ULS-Set(8)	213,5	0,0	0,0	OK
B1166	6,0	ULS-Set(8)	273,2	0,0	0,0	OK
B3048	10,0	ULS-Set(8)	175,3	0,0	0,0	OK

Design data

Material	f_y [MPa]	ϵ_{lim} [%]
S 355	355,0	5,0

Project:
Project no:
Author:



Overall check, ULS-Set(8)

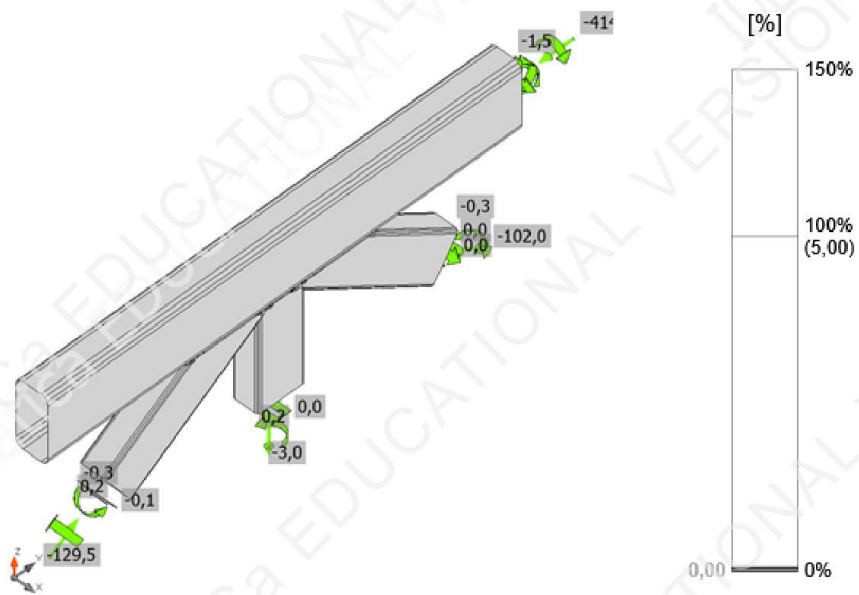

Strain check, ULS-Set(8)

Project:
Project no:
Author:

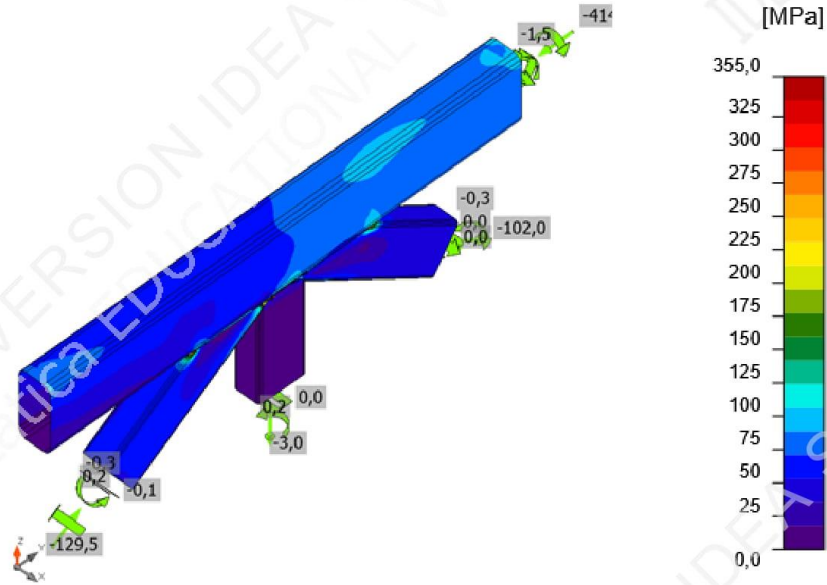

Equivalent stress, ULS-Set(8)

Welds (Plastic redistribution)

Item	Edge	Throat th. [mm]	Length [mm]	Loads	$\sigma_{w,Ed}$ [MPa]	ϵ_{pI} [%]	σ_{\perp} [MPa]	τ_{\parallel} [MPa]	τ_{\perp} [MPa]	Ut [%]	Ut _c [%]	Status
B3048-arc 12	B1166	▲3,0▲	194	ULS-Set(8)	427,5	0,4	-11,3	-195,1	-151,0	98,1	36,8	OK
B3048-arc 12	B1146	▲3,0▲	169	ULS-Set(8)	124,0	0,0	28,6	51,8	-46,6	28,5	8,8	OK
B3048-arc 12	B1165	▲4,0▲	194	ULS-Set(8)	338,0	0,0	95,9	72,8	172,4	77,6	27,1	OK
		▲3,0▲	194	ULS-Set(6)	426,9	0,0	-52,0	-209,7	125,9	98,0	40,4	OK
		▲3,0▲	169	ULS-Set(8)	164,8	0,0	-39,0	-91,9	-9,8	37,8	11,3	OK
		▲4,0▲	194	ULS-Set(8)	354,0	0,0	-34,3	-104,6	-174,5	81,3	24,4	OK

Design data

	β_w [-]	$\sigma_{w,Rd}$ [MPa]	0.9 σ [MPa]
S 355	0,90	435,6	352,8

Buckling

Buckling analysis was not calculated.

Project:
Project no:
Author:

Bill of material

Manufacturing operations

Name	Plates [mm]	Shape	Nr.	Welds [mm]	Length [mm]	Bolts	Nr.
CUT1				Double fillet: a = 3,0	194,2		
CUT2				Double fillet: a = 3,0	169,2		
CUT3				Double fillet: a = 4,0	194,2		

Welds

Type	Material	Throat thickness [mm]	Leg size [mm]	Length [mm]
Double fillet	S 355	3,0	4,2	363,4
Double fillet	S 355	4,0	5,7	194,2

Code settings

Item	Value	Unit	Reference
YM0	1,00	-	EN 1993-1-1: 6.1
YM1	1,00	-	EN 1993-1-1: 6.1
YM2	1,25	-	EN 1993-1-1: 6.1
YM3	1,25	-	EN 1993-1-8: 2.2
YC	1,50	-	EN 1992-1-1: 2.4.2.4
YInst	1,20	-	EN 1992-4: Table 4.1
Joint coefficient β_j	0,67	-	EN 1993-1-8: 6.2.5
Effective area - influence of mesh size	0,10	-	
Friction coefficient - concrete	0,25	-	EN 1993-1-8
Friction coefficient in slip-resistance	0,30	-	EN 1993-1-8 tab 3.7
Limit plastic strain	0,05	-	EN 1993-1-5
Weld stress evaluation	Plastic redistribution		
Detailing	No		
Distance between bolts [d]	2,20	-	EN 1993-1-8: tab 3.3
Distance between bolts and edge [d]	1,20	-	EN 1993-1-8: tab 3.3
Concrete breakout resistance check	Both		EN 1992-4: 7.2.1.4 and 7.2.2.5
Use calculated c_b in bearing check.	Yes		EN 1993-1-8: tab 3.4
Cracked concrete	Yes		EN 1992-4
Local deformation check	No		CIDECT DG 1, 3 - 1.1
Local deformation limit	0,03	-	CIDECT DG 1, 3 - 1.1
Geometrical nonlinearity (GMNA)	Yes		Allow large deformations of hollow sections
Braced system	No		EN 1993-1-8: 5.2.2.5

9.14. Spoj donjeg pojasa glavne rešetke s ispunama

Project:
Project no:
Author:

IDEA StatiCa®
Calculate yesterday's estimates

Material

Steel S 355

Project item Con N1014

Design

Name Con N1014
Description
Analysis Stress, strain/ loads in equilibrium

Beams and columns

Name	Cross-section	β - Direction [°]	γ - Pitch [°]	α - Rotation [°]	Offset ex [mm]	Offset ey [mm]	Offset ez [mm]	Forces in
B1145	1 - CFRHS140X80X6(RHS140x80)	0,0	0,0	90,0	0	0	0	Position
B1164	1 - CFRHS140X80X6(RHS140x80)	0,0	0,0	0,0	0	0	0	Position
B1165	1 - CFRHS140X80X6(RHS140x80)	0,0	0,0	0,0	0	0	0	Position
B5098	2 - CFRHS200X100X12.5(RHS200x100)	0,0	0,0	0,0	0	0	0	Position

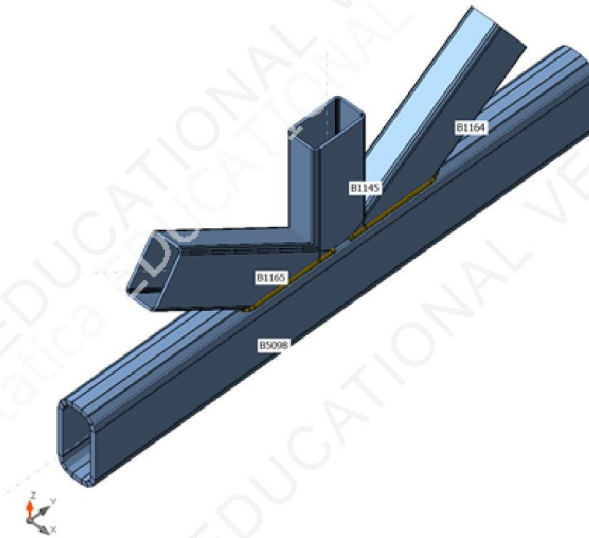

Project:
 Project no:
 Author:

Cross-sections

Name	Material
1 - CFRHS140X80X6(RHS140x80)	S 355
2 - CFRHS200X100X12.5(RHS200x100)	S 355

Cross-sections

Name	Material	Drawing
1 - CFRHS140X80X6(RHS140x80)	S 355	
2 - CFRHS200X100X12.5(RHS200x100)	S 355	

Project:
Project no:
Author:

Load effects (forces in equilibrium)

Name	Member	N [kN]	Vy [kN]	Vz [kN]	Mx [kNm]	My [kNm]	Mz [kNm]
ULS-Set(1)	B1145	-1,0	0,0	0,0	0,0	0,0	-0,1
	B1164	23,0	0,0	-0,2	0,0	0,0	-0,1
	B1165	26,5	0,0	-0,2	0,0	0,0	-0,1
	B5098	-88,6	0,0	-0,3	-0,3	0,9	0,1
ULS-Set(2)	B1145	-10,1	-0,1	0,0	-0,1	0,0	-0,2
	B1164	81,1	0,0	-0,3	-0,1	0,0	-0,2
	B1165	101,6	0,0	-0,3	0,0	0,0	-0,1
	B5098	-305,2	-0,1	-0,3	-0,9	2,5	0,3
ULS-Set(3)	B1145	-9,2	-0,1	0,0	-0,1	0,0	-0,2
	B1164	82,1	0,0	-0,3	-0,1	0,0	-0,2
	B1165	99,9	0,0	-0,3	0,0	0,0	-0,1
	B5098	-274,6	-0,1	0,0	-0,9	2,8	0,2
ULS-Set(4)	B1145	-1,1	0,0	0,0	0,0	0,0	-0,1
	B1164	20,0	0,0	-0,2	0,0	0,0	-0,1
	B1165	24,4	0,0	-0,2	0,0	0,0	-0,1
	B5098	-103,8	0,0	-0,5	-0,3	0,6	0,1
ULS-Set(5)	B1145	-5,5	0,0	0,0	-0,1	0,0	-0,1
	B1164	53,1	0,0	-0,3	-0,1	0,0	-0,2
	B1165	65,6	0,0	-0,3	0,0	0,0	-0,1
	B5098	-231,5	-0,1	-0,4	-0,7	1,7	0,2
ULS-Set(6)	B1145	-1,9	0,0	0,0	0,0	0,0	-0,1
	B1164	22,0	0,0	-0,2	0,0	0,0	-0,1
	B1165	28,1	0,0	-0,2	0,0	0,0	0,0
	B5098	-119,2	0,0	-0,6	-0,3	0,5	0,1
ULS-Set(7)	B1145	-9,1	-0,1	0,0	-0,1	0,0	-0,2
	B1164	83,7	0,0	-0,3	-0,1	0,0	-0,2
	B1165	101,5	0,0	-0,3	0,0	0,0	-0,1
	B5098	-283,3	-0,1	-0,1	-0,9	2,8	0,2
ULS-Set(8)	B1145	-1,0	0,0	0,0	0,0	0,0	-0,1
	B1164	19,2	0,0	-0,2	0,0	0,0	-0,1
	B1165	23,6	0,0	-0,2	0,0	0,0	-0,1
	B5098	-102,9	0,0	-0,5	-0,3	0,6	0,1
ULS-Set(9)	B1145	-10,0	-0,1	0,0	-0,1	0,0	-0,2
	B1164	80,3	0,0	-0,3	-0,1	0,0	-0,2
	B1165	100,6	0,0	-0,3	0,0	0,0	-0,1
	B5098	-304,1	-0,1	-0,3	-0,9	2,4	0,3
ULS-Set(10)	B1145	-10,0	-0,1	0,0	-0,1	0,0	-0,2
	B1164	82,6	0,0	-0,3	-0,1	0,0	-0,2
	B1165	103,1	0,0	-0,3	0,0	0,0	-0,1
	B5098	-313,7	-0,1	-0,4	-0,9	2,4	0,3

Project:
 Project no:
 Author:

Check

Summary

Name	Value	Status
Analysis	100,0%	OK
Plates	0,0 < 5,0%	OK
Welds	42,7 < 100%	OK
Buckling	Not calculated	
GMNA	Calculated	

Plates

Name	Thickness [mm]	Loads	σ_{Ed} [MPa]	ϵ_{p1} [%]	σ_{CEd} [MPa]	Status
B1145	6,0	ULS-Set(10)	69,1	0,0	0,0	OK
B1164	6,0	ULS-Set(10)	82,3	0,0	0,0	OK
B1165	6,0	ULS-Set(10)	124,6	0,0	0,0	OK
B5098	12,5	ULS-Set(10)	102,1	0,0	0,0	OK

Design data

Material	f_y [MPa]	ϵ_{lim} [%]
S 355	355,0	5,0

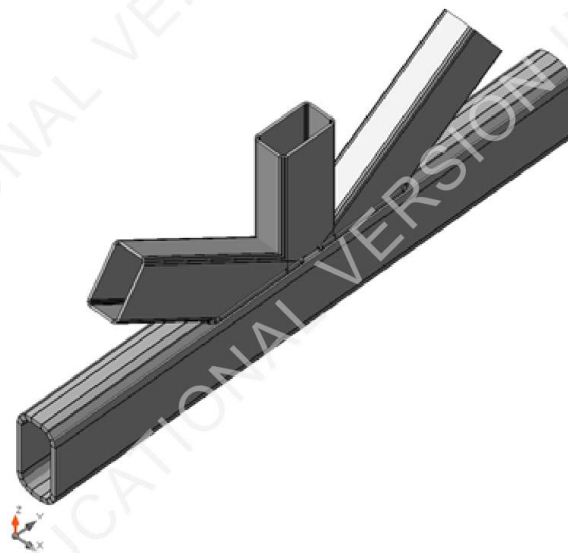

Overall check, ULS-Set(10)

Project:
 Project no:
 Author:

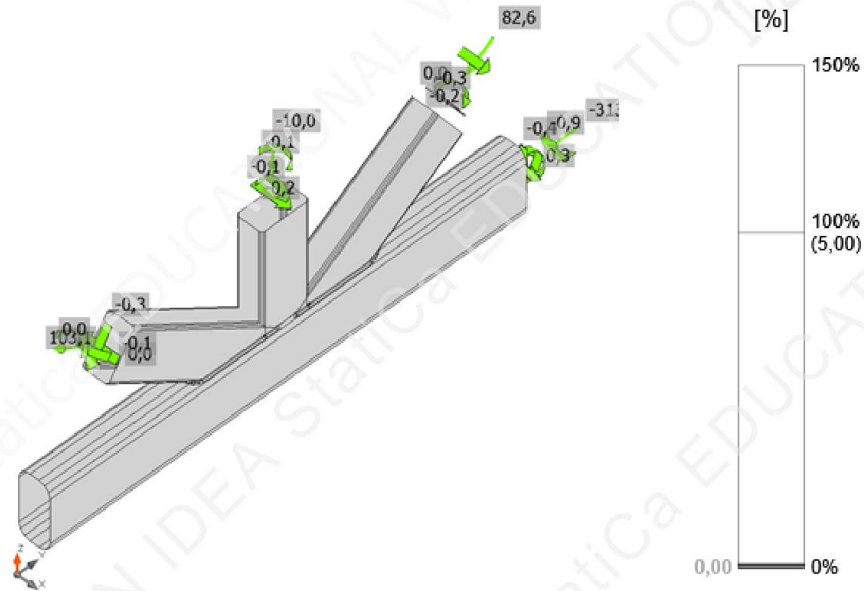

Strain check, ULS-Set(10)

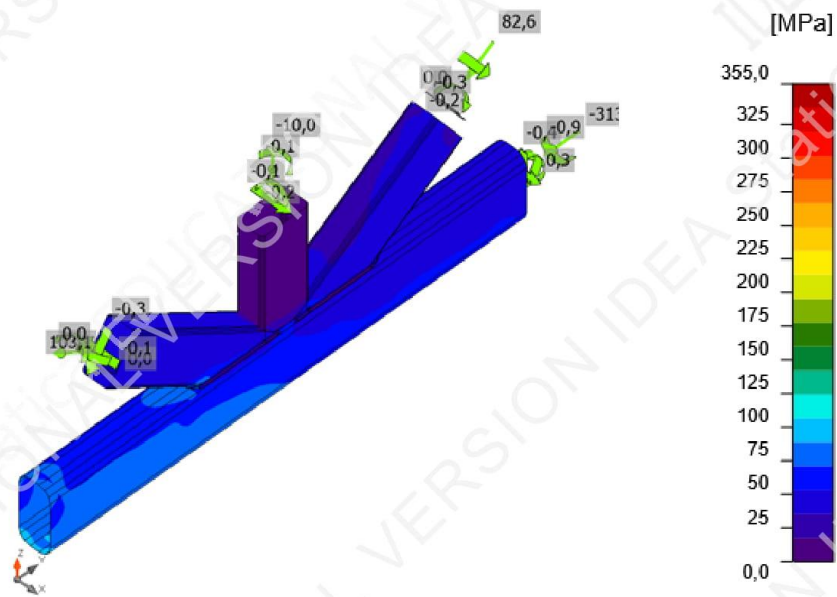

Equivalent stress, ULS-Set(10)

Project:
Project no:
Author:

Welds (Plastic redistribution)

Item	Edge	Throat th. [mm]	Length [mm]	Loads	$\sigma_{w,Ed}$ [MPa]	ϵ_{pl} [%]	σ_{\perp} [MPa]	τ_{\parallel} [MPa]	τ_{\perp} [MPa]	Ut [%]	Ut _c [%]	Status
B5098-arc 7	B1165	4,0	619	ULS-Set(10)	125,9	0,0	22,7	69,7	15,7	28,9	12,7	OK
B5098-arc 5	B1145	4,0	174	ULS-Set(10)	185,8	0,0	97,3	-10,9	-90,8	42,7	6,6	OK
B5098-arc 8	B1164	4,0	619	ULS-Set(10)	153,9	0,0	5,7	-5,7	-88,6	35,3	7,7	OK
		4,0	619	ULS-Set(10)	155,0	0,0	-56,5	-62,1	-55,6	35,6	5,8	OK
		4,0	174	ULS-Set(10)	117,8	0,0	-104,0	-10,9	-30,0	29,5	7,2	OK
		4,0	619	ULS-Set(10)	96,2	0,0	5,9	-34,9	43,1	22,1	4,6	OK

Design data

	β_w [-]	$\sigma_{w,Rd}$ [MPa]	0.9σ [MPa]
S 355	0,90	435,6	352,8

Buckling

Buckling analysis was not calculated.

Bill of material

Manufacturing operations

Name	Plates [mm]	Shape	Nr.	Welds [mm]	Length [mm]	Bolts	Nr.
CUT1				Double fillet: a = 4,0	618,8		
CUT2				Double fillet: a = 4,0	173,8		
CUT3				Double fillet: a = 4,0	618,8		

Welds

Type	Material	Throat thickness [mm]	Leg size [mm]	Length [mm]
Double fillet	S 355	4,0	5,7	1411,3

Code settings

Item	Value	Unit	Reference
Y _{M0}	1,00	-	EN 1993-1-1: 6.1
Y _{M1}	1,00	-	EN 1993-1-1: 6.1
Y _{M2}	1,25	-	EN 1993-1-1: 6.1
Y _{M3}	1,25	-	EN 1993-1-8: 2.2
Y _C	1,50	-	EN 1992-1-1: 2.4.2.4
Y _{Inst}	1,20	-	EN 1992-4: Table 4.1
Joint coefficient β_j	0,67	-	EN 1993-1-8: 6.2.5
Effective area - influence of mesh size	0,10	-	
Friction coefficient - concrete	0,25	-	EN 1993-1-8
Friction coefficient in slip-resistance	0,30	-	EN 1993-1-8 tab 3.7

Project:
Project no:
Author:

Item	Value	Unit	Reference
Limit plastic strain	0,05	-	EN 1993-1-5
Weld stress evaluation	Plastic redistribution		
Detailing	No		
Distance between bolts [d]	2,20	-	EN 1993-1-8: tab 3.3
Distance between bolts and edge [d]	1,20	-	EN 1993-1-8: tab 3.3
Concrete breakout resistance check	Both		EN 1992-4: 7.2.1.4 and 7.2.2.5
Use calculated a_b in bearing check.	Yes		EN 1993-1-8: tab 3.4
Cracked concrete	Yes		EN 1992-4
Local deformation check	No		CIDECT DG 1, 3 - 1.1
Local deformation limit	0,03	-	CIDECT DG 1, 3 - 1.1
Geometrical nonlinearity (GMNA)	Yes		Allow large deformations of hollow sections
Braced system	No		EN 1993-1-8: 5.2.2.5

9.15. Nastavak podrožnice

Project:
Project no:
Author:

IDEA StatiCa[®]
Calculate yesterday's estimates

Material

Steel S 355

Project item Con N1017

Design

Name Con N1017
Description
Analysis Stress, strain/ loads in equilibrium

Beams and columns

Name	Cross-section	β - Direction [°]	γ - Pitch [°]	α - Rotation [°]	Offset ex [mm]	Offset ey [mm]	Offset ez [mm]	Forces in
B2862	2 - HEB240	0,0	0,0	0,0	0	0	0	Position
B2863	2 - HEB240	0,0	0,0	0,0	0	0	0	Position

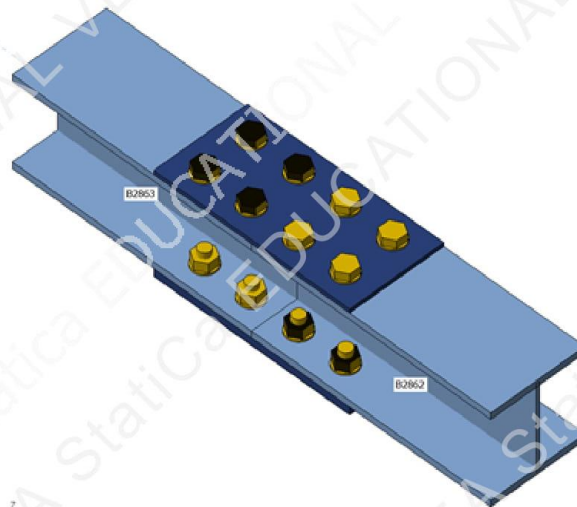

Cross-sections

Name	Material
2 - HEB240	S 355

Project:
Project no:
Author:

Cross-sections

Name	Material	Drawing
2 - HEB240	S 355	

Bolts

Name	Bolt assembly	Diameter [mm]	fu [MPa]	Gross area [mm ²]
M30 10.9	M30 10.9	30	1000,0	707

Load effects (forces in equilibrium)

Name	Member	N [kN]	Vy [kN]	Vz [kN]	Mx [kNm]	My [kNm]	Mz [kNm]
ULS-Set(1)	B2862	-1505,4	-0,2	-5,7	0,0	20,0	0,5
	B2863	1505,2	-0,5	-2,7	0,0	-20,5	0,2
ULS-Set(2)	B2862	942,1	0,1	-2,0	0,0	10,6	-0,6
	B2863	-942,2	0,6	-0,5	0,0	-10,9	0,9
ULS-Set(3)	B2862	-1505,2	-0,2	-2,1	0,0	11,3	0,7
	B2863	1505,0	-0,6	-0,6	0,0	-11,6	-0,3
ULS-Set(4)	B2862	943,1	0,1	-5,5	0,0	19,6	-0,8
	B2863	-943,2	0,8	-2,4	0,0	-20,2	1,7
ULS-Set(5)	B2862	2,1	0,0	-3,7	0,0	17,2	-0,3
	B2863	-2,2	0,3	-1,3	0,0	-17,7	1,3
ULS-Set(6)	B2862	566,5	0,0	-6,4	0,0	20,8	-0,6
	B2863	-566,6	0,5	-3,3	0,0	-21,5	1,3
ULS-Set(7)	B2862	0,3	0,0	-0,6	0,0	9,0	-0,2
	B2863	-0,3	0,2	0,6	0,0	-9,1	0,9
ULS-Set(8)	B2862	-901,7	-0,2	-6,5	0,0	22,1	0,1
	B2863	901,5	0,0	-3,1	-0,1	-22,7	1,2
ULS-Set(9)	B2862	567,3	0,0	-6,5	0,0	21,7	-0,7
	B2863	-567,4	0,7	-3,1	-0,1	-22,4	1,8
ULS-Set(10)	B2862	-904,1	-0,1	-0,9	0,0	9,4	0,3
	B2863	903,9	-0,3	0,3	0,0	-9,5	0,2

Project:
Project no:
Author:

Check

Summary

Name	Value	Status
Analysis	100,0%	OK
Plates	2,8 < 5,0%	OK
Bolts	93,0 < 100%	OK
Buckling	Not calculated	

Plates

Name	Thickness [mm]	Loads	σ_{Ed} [MPa]	ϵ_{pl} [%]	σ_{CEd} [MPa]	Status
B2862-bfl 1	17,0	ULS-Set(1)	355,3	0,1	9,4	OK
B2862-tfl 1	17,0	ULS-Set(3)	324,6	0,1	26,7	OK
B2862-w 1	10,0	ULS-Set(1)	171,6	0,0	0,0	OK
B2863-bfl 1	17,0	ULS-Set(1)	355,3	0,1	9,4	OK
B2863-tfl 1	17,0	ULS-Set(3)	324,4	0,1	26,6	OK
B2863-w 1	10,0	ULS-Set(1)	170,6	0,0	0,0	OK
SPL1	20,0	ULS-Set(3)	355,2	0,1	10,5	OK
SPL3	10,0	ULS-Set(3)	360,9	2,8	26,7	OK

Design data

Material	f_y [MPa]	ϵ_{lim} [%]
S 355	355,0	5,0

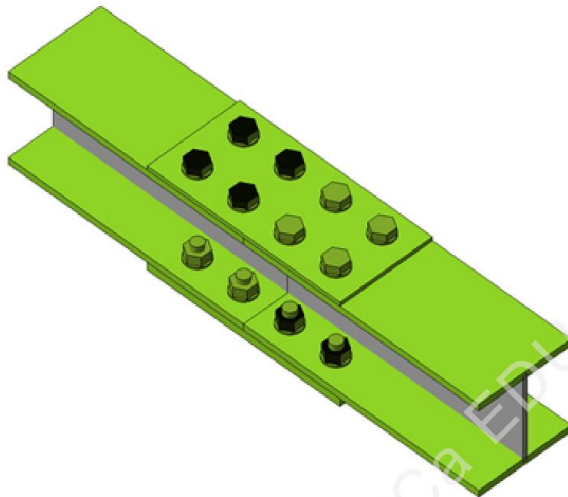

Project:
Project no:
Author:

Overall check, ULS-Set(3)

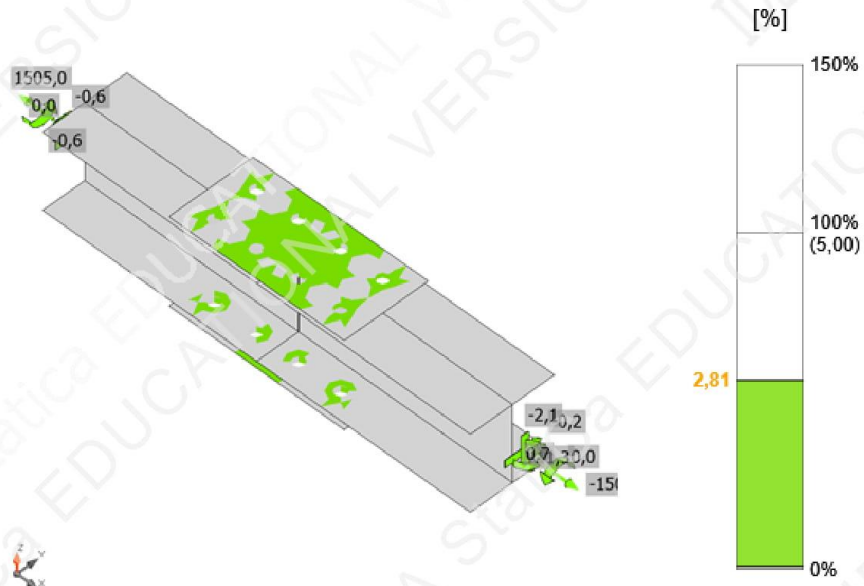

Strain check, ULS-Set(3)

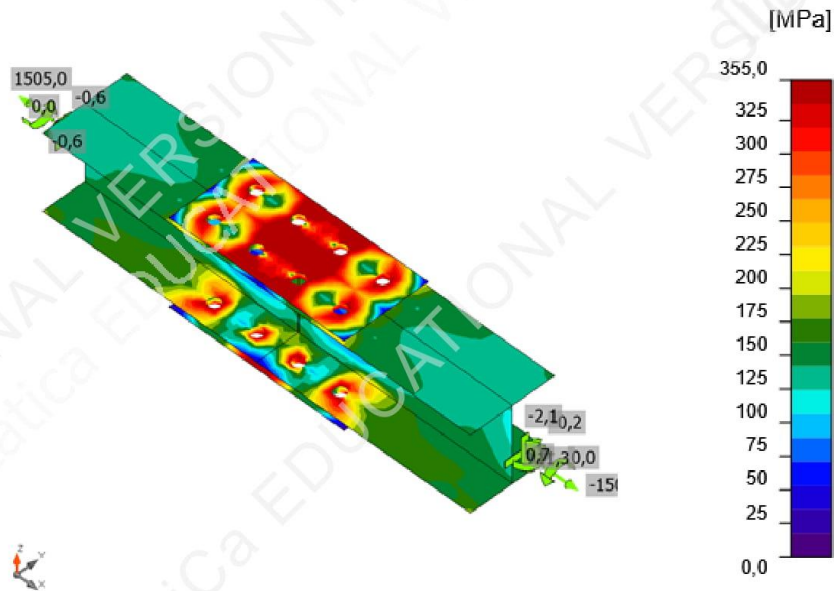

Equivalent stress, ULS-Set(3)

Project:
Project no:
Author:

Bolts

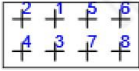
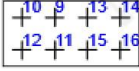
	Name	Grade	Loads	$F_{t,Ed}$ [kN]	V [kN]	$U_{t,t}$ [%]	$F_{b,Rd}$ [kN]	$U_{t,s}$ [%]	$U_{t,ts}$ [%]	Status
	B1	M30 10.9 - 1	ULS-Set(1)	17,1	208,1	4,2	303,1	92,7	0,0	OK
	B2	M30 10.9 - 1	ULS-Set(1)	42,4	205,4	10,5	415,8	91,6	0,0	OK
	B3	M30 10.9 - 1	ULS-Set(1)	17,1	208,6	4,2	303,1	93,0	0,0	OK
	B4	M30 10.9 - 1	ULS-Set(1)	42,3	205,9	10,5	415,8	91,8	0,0	OK
	B5	M30 10.9 - 1	ULS-Set(1)	16,5	207,8	4,1	303,1	92,6	0,0	OK
	B6	M30 10.9 - 1	ULS-Set(1)	42,4	205,3	10,5	415,8	91,5	0,0	OK
	B7	M30 10.9 - 1	ULS-Set(1)	16,5	208,7	4,1	303,1	93,0	0,0	OK
	B8	M30 10.9 - 1	ULS-Set(1)	42,4	206,2	10,5	415,8	91,9	0,0	OK
	B9	M30 10.9 - 2	ULS-Set(3)	41,9	173,1	10,8	282,9	77,1	0,0	OK
	B10	M30 10.9 - 2	ULS-Set(3)	54,8	181,1	14,1	207,9	87,1	0,0	OK
	B11	M30 10.9 - 2	ULS-Set(3)	41,7	173,1	10,7	282,9	77,2	0,0	OK
	B12	M30 10.9 - 2	ULS-Set(3)	54,8	181,0	14,1	207,9	87,1	0,0	OK
	B13	M30 10.9 - 2	ULS-Set(3)	41,9	173,1	10,8	282,9	77,1	0,0	OK
	B14	M30 10.9 - 2	ULS-Set(3)	54,8	181,0	14,1	207,9	87,1	0,0	OK
	B15	M30 10.9 - 2	ULS-Set(3)	41,9	173,1	10,8	282,9	77,2	0,0	OK
	B16	M30 10.9 - 2	ULS-Set(3)	54,8	181,1	14,1	207,9	87,1	0,0	OK

Design data



Name	$F_{t,Rd}$ [kN]	$B_{p,Rd}$ [kN]	$F_{v,Rd}$ [kN]
M30 10.9 - 1	403,9	661,8	224,4
M30 10.9 - 2	403,9	389,3	224,4

Buckling

Buckling analysis was not calculated.

Bill of material

Manufacturing operations

Name	Plates [mm]	Shape	Nr.	Welds [mm]	Length [mm]	Bolts	Nr.
SPL1	P20,0x500,0-240,0 (S 355)		1			M30 10.9	8
SPL3	P10,0x500,0-240,0 (S 355)		1			M30 10.9	8

Project:
Project no:
Author:

Bolts

Name	Grip length [mm]	Count
M30 10.9	37	8
M30 10.9	27	8

Code settings

Item	Value	Unit	Reference
Ym0	1,00	-	EN 1993-1-1: 6.1
Ym1	1,00	-	EN 1993-1-1: 6.1
Ym2	1,25	-	EN 1993-1-1: 6.1
Ym3	1,25	-	EN 1993-1-8: 2.2
Yc	1,50	-	EN 1992-1-1: 2.4.2.4
YInst	1,20	-	EN 1992-4: Table 4.1
Joint coefficient β_j	0,67	-	EN 1993-1-8: 6.2.5
Effective area - influence of mesh size	0,10	-	
Friction coefficient - concrete	0,25	-	EN 1993-1-8
Friction coefficient in slip-resistance	0,30	-	EN 1993-1-8 tab 3.7
Limit plastic strain	0,05	-	EN 1993-1-5
Weld stress evaluation	Plastic redistribution		
Detailing	No		
Distance between bolts [d]	2,20	-	EN 1993-1-8: tab 3.3
Distance between bolts and edge [d]	1,20	-	EN 1993-1-8: tab 3.3
Concrete breakout resistance check	Both		EN 1992-4: 7.2.1.4 and 7.2.2.5
Use calculated σ_{tb} in bearing check.	Yes		EN 1993-1-8: tab 3.4
Cracked concrete	Yes		EN 1992-4
Local deformation check	No		CIDECT DG 1, 3 - 1.1
Local deformation limit	0,03	-	CIDECT DG 1, 3 - 1.1
Geometrical nonlinearity (GMNA)	Yes		Allow large deformations of hollow sections
Braced system	No		EN 1993-1-8: 5.2.2.5

9.16. Spoj stupa sa gredama

Project:
Project no:
Author:

IDEA StatiCa®
Calculate yesterday's estimates

Material

Steel S 355

Project item Con N2395

Design

Name Con N2395
Description
Analysis Stress, strain/ loads in equilibrium

Beams and columns

Name	Cross-section	β - Direction [°]	γ - Pitch [°]	α - Rotation [°]	Offset ex [mm]	Offset ey [mm]	Offset ez [mm]	Forces in
B2194	1 - HEM280	0,0	0,0	0,0	0	0	0	Position
B2267	2 - HEB160	0,0	0,0	0,0	0	0	0	Position
B3429	2 - HEB160	0,0	0,0	0,0	0	0	0	Position
B3430	2 - HEB160	0,0	0,0	0,0	0	0	0	Position
B3468	2 - HEB160	0,0	0,0	0,0	0	0	0	Position

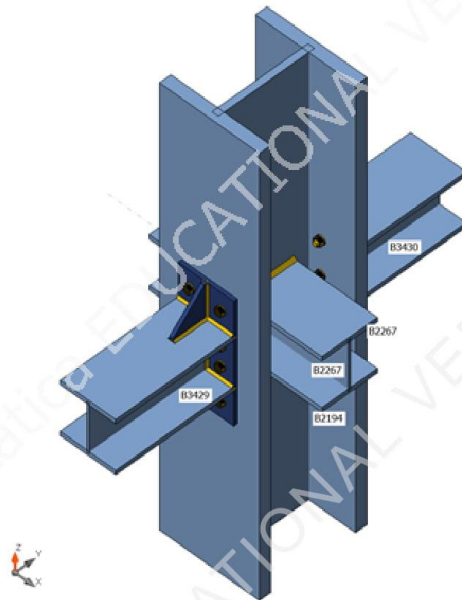

Cross-sections

Name	Material
1 - HEM280	S 355
2 - HEB160	S 355

Project:
 Project no:
 Author:

Cross-sections

Name	Material	Drawing
1 - HEM280	S 355	
2 - HEB160	S 355	

Bolts

Name	Bolt assembly	Diameter [mm]	fu [MPa]	Gross area [mm ²]
M12 10.9	M12 10.9	12	1000,0	113

Project:
 Project no:
 Author:



Load effects (forces in equilibrium)

Name	Member	N [kN]	Vy [kN]	Vz [kN]	Mx [kNm]	My [kNm]	Mz [kNm]
ULS-Set(1)	B2194	953,4	6,3	-38,6	0,0	-57,6	-18,8
	B2267	-65,5	0,0	-1,0	0,0	0,0	0,0
	B3429	-141,2	0,0	-0,8	0,0	0,0	0,0
	B3430	141,9	0,0	-1,5	0,0	0,0	0,0
	B3468	68,6	0,0	-0,6	0,0	0,0	0,0
ULS-Set(2)	B2194	1812,5	24,1	-23,0	0,0	-60,3	-72,3
	B2267	39,9	0,0	-1,4	0,0	0,0	0,0
	B3429	88,2	0,0	-1,1	0,0	0,0	0,0
	B3430	-85,4	0,0	-2,0	0,0	0,0	0,0
	B3468	-38,0	0,0	-0,8	0,0	0,0	0,0
ULS-Set(3)	B2194	1806,5	25,8	-21,1	0,0	-53,5	-77,3
	B2267	67,1	0,0	-1,4	0,0	0,0	0,0
	B3429	147,0	0,0	-1,1	0,0	0,0	0,0
	B3430	-144,0	0,0	-2,0	0,0	0,0	0,0
	B3468	-65,8	0,0	-0,8	0,0	0,0	0,0
ULS-Set(4)	B2194	957,5	3,6	-47,1	0,0	-70,6	-10,9
	B2267	-109,0	0,0	-1,0	0,0	0,0	0,0
	B3429	-235,2	0,0	-0,8	0,0	0,0	0,0
	B3430	235,6	0,0	-1,5	0,0	0,0	0,0
	B3468	113,2	0,0	-0,6	0,0	0,0	0,0
ULS-Set(5)	B2194	960,8	14,3	1,0	0,0	-12,7	-43,0
	B2267	67,5	0,0	-1,0	0,0	0,0	0,0
	B3429	146,9	0,0	-0,8	0,0	0,0	0,0
	B3430	-145,2	0,0	-1,5	0,0	0,0	0,0
	B3468	-67,8	0,0	-0,6	0,0	0,0	0,0
ULS-Set(6)	B2194	1803,1	15,1	-69,2	0,0	-111,3	-45,2
	B2267	-109,5	0,0	-1,4	0,0	0,0	0,0
	B3429	-235,1	0,0	-1,1	0,0	0,0	0,0
	B3430	236,8	0,0	-2,0	0,0	0,0	0,0
	B3468	115,2	0,0	-0,8	0,0	0,0	0,0
ULS-Set(7)	B2194	1297,0	13,8	-22,2	0,0	-46,7	-41,5
	B2267	-0,5	0,0	-1,4	0,0	0,0	0,0
	B3429	-0,3	0,0	-1,1	0,0	0,0	0,0
	B3430	1,9	0,0	-2,0	0,0	0,0	0,0
	B3468	2,4	0,0	-0,8	0,0	0,0	0,0
ULS-Set(8)	B2194	957,0	3,7	-50,5	0,0	-71,9	-11,1
	B2267	-109,1	0,0	-1,0	0,0	0,0	0,0
	B3429	-235,1	0,0	-0,8	0,0	0,0	0,0
	B3430	235,5	0,0	-1,5	0,0	0,0	0,0
	B3468	113,2	0,0	-0,6	0,0	0,0	0,0
ULS-Set(9)	B2194	954,4	3,7	-50,5	0,0	-71,8	-11,0

Project:
Project no:
Author:



Name	Member	N [kN]	Vy [kN]	Vz [kN]	Mx [kNm]	My [kNm]	Mz [kNm]
	B2267	-109,0	0,0	-1,0	0,0	0,0	0,0
	B3429	-235,2	0,0	-0,8	0,0	0,0	0,0
	B3430	235,6	0,0	-1,5	0,0	0,0	0,0
	B3468	113,2	0,0	-0,6	0,0	0,0	0,0
ULS-Set(10)	B2194	957,7	14,4	-2,4	0,0	-14,0	-43,1
	B2267	67,5	0,0	-1,0	0,0	0,0	0,0
	B3429	146,9	0,0	-0,8	0,0	0,0	0,0
	B3430	-145,2	0,0	-1,5	0,0	0,0	0,0
	B3468	-67,8	0,0	-0,6	0,0	0,0	0,0

Check

Summary

Name	Value	Status
Analysis	100,0%	OK
Plates	0,0 < 5,0%	OK
Bolts	54,9 < 100%	OK
Welds	40,6 < 100%	OK
Buckling	Not calculated	

Project:
 Project no:
 Author:



Plates

Name	Thickness [mm]	Loads	σ_{Ed} [MPa]	ϵ_{pl} [%]	$\sigma_{C_{Ed}}$ [MPa]	Status
B2194-bfl 1	33,0	ULS-Set(6)	232,1	0,0	10,2	OK
B2194-tfl 1	33,0	ULS-Set(3)	143,2	0,0	6,0	OK
B2194-w 1	18,5	ULS-Set(6)	125,6	0,0	0,0	OK
B2267-bfl 1	13,0	ULS-Set(3)	43,9	0,0	0,0	OK
B2267-tfl 1	13,0	ULS-Set(3)	45,6	0,0	0,0	OK
B2267-w 1	8,0	ULS-Set(3)	65,2	0,0	0,0	OK
B3429-bfl 1	13,0	ULS-Set(6)	79,6	0,0	0,0	OK
B3429-tfl 1	13,0	ULS-Set(6)	78,8	0,0	0,0	OK
B3429-w 1	8,0	ULS-Set(6)	78,8	0,0	0,0	OK
B3430-bfl 1	13,0	ULS-Set(4)	74,8	0,0	0,0	OK
B3430-tfl 1	13,0	ULS-Set(4)	73,6	0,0	0,0	OK
B3430-w 1	8,0	ULS-Set(6)	77,2	0,0	0,0	OK
B3468-bfl 1	13,0	ULS-Set(3)	50,7	0,0	0,0	OK
B3468-tfl 1	13,0	ULS-Set(3)	53,0	0,0	0,0	OK
B3468-w 1	8,0	ULS-Set(3)	75,8	0,0	0,0	OK
EP1	10,0	ULS-Set(6)	343,0	0,0	9,9	OK
WID1a	10,0	ULS-Set(4)	97,9	0,0	0,0	OK
WID1b	10,0	ULS-Set(4)	95,4	0,0	0,0	OK
EP2	10,0	ULS-Set(6)	331,3	0,0	10,2	OK
WID2a	10,0	ULS-Set(9)	96,5	0,0	0,0	OK
WID2b	10,0	ULS-Set(6)	102,2	0,0	0,0	OK

Design data

Material	f_y [MPa]	ϵ_{lim} [%]
S 355	355,0	5,0

Project:
 Project no:
 Author:

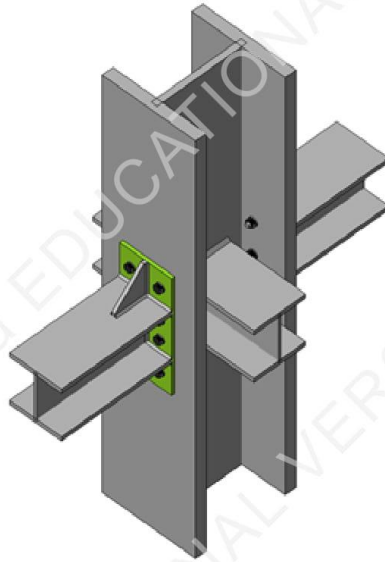

Overall check, ULS-Set(6)

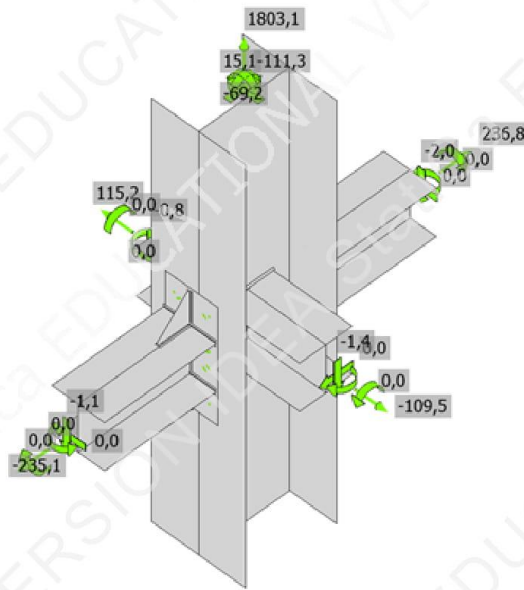

Strain check, ULS-Set(6)

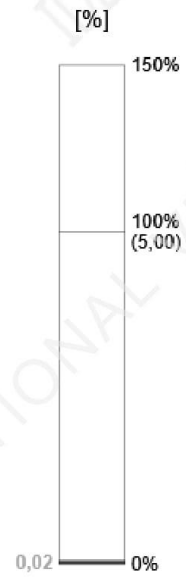

Project:
Project no:
Author:

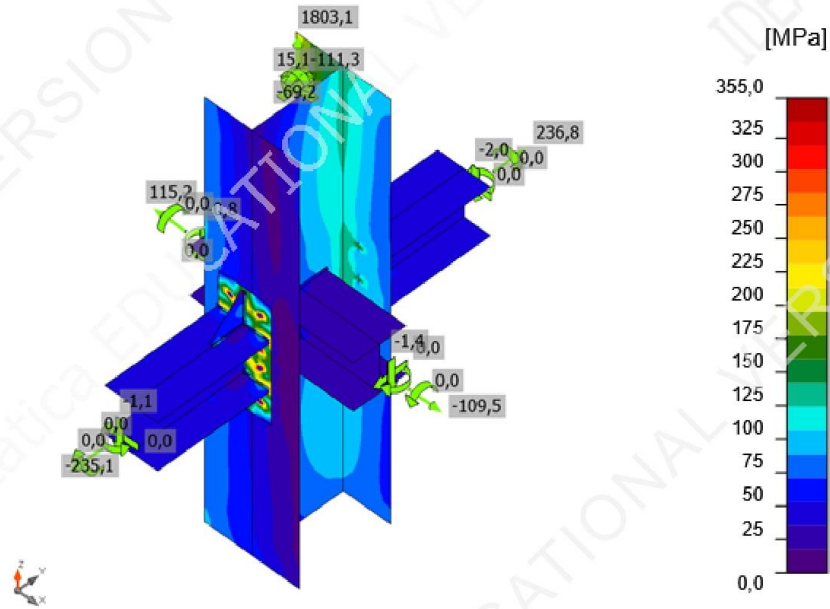

Equivalent stress, ULS-Set(6)

Bolts

	Name	Loads	F _{t,Ed} [kN]	V [kN]	U _t [%]	F _{b,Rd} [kN]	U _{ts} [%]	U _{ts} [%]	Status
	B1	ULS-Set(4)	29,6	1,8	48,9	117,6	5,4	40,3	OK
	B2	ULS-Set(4)	29,6	1,9	48,9	117,6	5,6	40,5	OK
	B3	ULS-Set(6)	32,9	1,1	54,3	117,6	3,3	42,1	OK
	B4	ULS-Set(6)	32,8	1,3	54,3	117,6	3,8	42,6	OK
	B5	ULS-Set(4)	30,0	1,7	49,6	117,6	5,0	40,5	OK
	B6	ULS-Set(4)	30,0	1,7	49,6	117,6	5,2	40,6	OK
	B7	ULS-Set(6)	33,2	1,4	54,9	117,6	4,1	43,4	OK
	B8	ULS-Set(6)	33,2	1,5	54,8	117,6	4,4	43,6	OK
	B9	ULS-Set(6)	30,1	4,2	49,8	117,6	12,6	48,2	OK
	B10	ULS-Set(6)	30,2	3,7	49,9	117,6	11,0	46,6	OK
	B11	ULS-Set(4)	32,2	0,9	53,2	117,6	2,8	40,8	OK
	B12	ULS-Set(4)	32,2	0,9	53,3	117,6	2,7	40,7	OK
	B13	ULS-Set(6)	31,1	3,7	51,5	117,6	11,0	47,8	OK
	B14	ULS-Set(6)	31,2	3,3	51,7	117,6	9,8	46,7	OK
	B15	ULS-Set(6)	32,7	1,0	54,0	117,6	3,0	41,6	OK
	B16	ULS-Set(6)	32,8	0,9	54,2	117,6	2,6	41,2	OK

Design data

Name	F _{t,Rd} [kN]	B _{p,Rd} [kN]	F _{v,Rd} [kN]
M12 10.9 - 1	60,5	169,9	33,6

Project:
Project no:
Author:

Welds (Plastic redistribution)

Item	Edge	Throat th. [mm]	Length [mm]	Loads	$\sigma_{w,Ed}$ [MPa]	ϵ_{pl} [%]	σ_{\perp} [MPa]	τ_{\parallel} [MPa]	τ_{\perp} [MPa]	Ut [%]	Ut _c [%]	Status
EP1	B3429-bfl 1	▲4,0▲	160	ULS-Set(6)	160,4	0,0	94,2	18,0	72,8	36,8	23,4	OK
		▲4,0▲	160	ULS-Set(6)	120,1	0,0	43,0	-6,5	-64,4	27,6	14,4	OK
EP1	B3429-tfl 1	▲4,0▲	160	ULS-Set(4)	117,2	0,0	42,4	7,8	62,6	26,9	15,2	OK
		▲4,0▲	160	ULS-Set(6)	155,8	0,0	91,0	-18,7	-70,6	35,8	23,9	OK
EP1	B3429-w 1	▲4,0▲	147	ULS-Set(6)	176,8	0,0	88,1	5,9	88,3	40,6	21,7	OK
		▲4,0▲	147	ULS-Set(6)	176,6	0,0	88,4	-5,2	-88,1	40,5	21,7	OK
EP1	WID1a	▲4,0▲	100	ULS-Set(4)	138,1	0,0	38,9	-66,1	38,5	31,7	23,6	OK
		▲4,0▲	100	ULS-Set(6)	138,5	0,0	38,3	66,4	-38,6	31,8	23,6	OK
B3429-bfl 1	WID1a	▲4,0▲	100	ULS-Set(4)	167,4	0,0	53,4	74,5	53,3	38,4	18,0	OK
		▲4,0▲	100	ULS-Set(4)	167,4	0,0	53,3	-74,5	-53,3	38,4	17,9	OK
EP1	WID1b	▲4,0▲	100	ULS-Set(4)	137,3	0,0	37,6	-66,0	38,1	31,5	23,2	OK
		▲4,0▲	100	ULS-Set(4)	136,8	0,0	38,5	65,6	-37,9	31,4	23,2	OK
B3429-tfl 1	WID1b	▲4,0▲	100	ULS-Set(4)	161,6	0,0	51,8	71,6	51,8	37,1	17,6	OK
		▲4,0▲	100	ULS-Set(4)	161,6	0,0	51,8	-71,6	-51,8	37,1	17,6	OK
EP2	B3430-bfl 1	▲4,0▲	160	ULS-Set(6)	156,6	0,0	91,0	-15,0	72,0	35,9	22,4	OK
		▲4,0▲	160	ULS-Set(6)	126,4	0,0	47,8	-10,4	-66,7	29,0	15,5	OK
EP2	B3430-tfl 1	▲4,0▲	160	ULS-Set(6)	121,2	0,0	46,1	10,6	63,8	27,8	15,9	OK
		▲4,0▲	160	ULS-Set(4)	151,0	0,0	87,6	-16,0	-69,1	34,7	23,0	OK
EP2	B3430-w 1	▲4,0▲	147	ULS-Set(6)	173,3	0,0	86,8	-6,3	86,4	39,8	21,3	OK
		▲4,0▲	147	ULS-Set(6)	173,5	0,0	86,2	6,9	-86,7	39,8	21,3	OK
EP2	WID2a	▲4,0▲	100	ULS-Set(6)	140,1	0,0	38,8	-67,1	39,3	32,2	23,5	OK
		▲4,0▲	100	ULS-Set(6)	141,0	0,0	39,8	67,5	-39,3	32,4	23,6	OK
B3430-tfl 1	WID2a	▲4,0▲	100	ULS-Set(9)	163,2	0,0	52,6	72,1	52,5	37,5	17,9	OK
		▲4,0▲	100	ULS-Set(9)	163,2	0,0	52,5	-72,1	-52,5	37,5	17,9	OK
EP2	WID2b	▲4,0▲	100	ULS-Set(6)	145,0	0,0	41,0	-69,2	40,7	33,3	24,5	OK
		▲4,0▲	100	ULS-Set(6)	143,3	0,0	40,2	68,3	-40,6	32,9	24,3	OK
B3430-bfl 1	WID2b	▲4,0▲	100	ULS-Set(6)	174,2	0,0	55,6	77,3	55,7	40,0	18,7	OK
		▲4,0▲	100	ULS-Set(6)	174,4	0,0	55,8	-77,5	-55,7	40,1	18,8	OK
B2194-w 1	B3468-bfl 1	▲6,5▲	160	ULS-Set(3)	80,4	0,0	-21,5	39,9	-20,3	18,5	9,1	OK
		▲6,5▲	160	ULS-Set(3)	67,5	0,0	-14,2	-34,8	15,5	15,5	6,1	OK
B2194-w 1	B3468-tfl 1	▲6,5▲	160	ULS-Set(3)	69,3	0,0	-14,2	35,9	-15,7	15,9	6,3	OK
		▲6,5▲	160	ULS-Set(3)	83,5	0,0	-22,9	-41,1	21,4	19,2	9,3	OK
B2194-w 1	B3468-w 1	▲4,0▲	147	ULS-Set(6)	65,7	0,0	15,6	-30,2	21,1	15,1	6,8	OK
		▲4,0▲	147	ULS-Set(6)	66,0	0,0	20,2	-31,3	-18,3	15,1	7,3	OK
B2194-w 1	B2267-bfl 1	▲6,5▲	160	ULS-Set(3)	74,9	0,0	-17,6	-37,0	-19,9	17,2	8,2	OK
		▲6,5▲	160	ULS-Set(3)	72,6	0,0	-18,1	37,4	15,8	16,7	7,0	OK
B2194-w 1	B2267-tfl 1	▲6,5▲	160	ULS-Set(3)	73,4	0,0	-17,9	-38,0	-15,7	16,8	7,1	OK
		▲6,5▲	160	ULS-Set(3)	76,9	0,0	-18,6	37,7	20,8	17,7	8,4	OK
B2194-w 1	B2267-w 1	▲4,0▲	147	ULS-Set(6)	62,6	0,0	19,6	23,5	25,0	14,4	7,4	OK

Project:
Project no:
Author:

Item	Edge	Throat th. [mm]	Length [mm]	Loads	$\sigma_{w,Ed}$ [MPa]	ϵ_{pl} [%]	σ_{\perp} [MPa]	τ_{\parallel} [MPa]	τ_{\perp} [MPa]	Ut [%]	Ut _c [%]	Status
		▲4,0▲	147	ULS-Set(6)	61,3	0,0	23,6	24,2	-21,9	14,1	7,8	OK

Design data



	β_w [-]	$\sigma_{w,Rd}$ [MPa]	0.9 σ [MPa]
S 355	0,90	435,6	352,8

Buckling

Buckling analysis was not calculated.

Bill of material

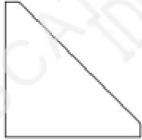
Manufacturing operations

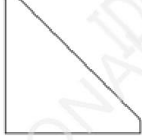
Name	Plates [mm]	Shape	Nr.	Welds [mm]	Length [mm]	Bolts	Nr.
EP1	P10,0x160,0-360,0 (S 355)		1	Double fillet: a = 4,0	467,0	M12 10.9	8
WID1	P10,0x100,0-100,0 (S 355)		2	Double fillet: a = 4,0	400,0		
EP2	P10,0x160,0-360,0 (S 355)		1	Double fillet: a = 4,0	467,0	M12 10.9	8
WID2	P10,0x100,0-100,0 (S 355)		2	Double fillet: a = 4,0	400,0		
CUT1				Double fillet: a = 6,5 Double fillet: a = 4,0	320,0 147,0		
CUT2				Double fillet: a = 6,5 Double fillet: a = 4,0	320,0 147,0		

Welds

Type	Material	Throat thickness [mm]	Leg size [mm]	Length [mm]
Double fillet	S 355	4,0	5,7	2028,0
Double fillet	S 355	6,5	9,2	640,0

Project:
Project no:
Author:



Bolts

Name	Grip length [mm]	Count
M12 10.9	43	16

Code settings

Item	Value	Unit	Reference
YM0	1,00	-	EN 1993-1-1: 6.1
YM1	1,00	-	EN 1993-1-1: 6.1
YM2	1,25	-	EN 1993-1-1: 6.1
YM3	1,25	-	EN 1993-1-8: 2.2
YC	1,50	-	EN 1992-1-1: 2.4.2.4
YInst	1,20	-	EN 1992-4: Table 4.1
Joint coefficient β_j	0,67	-	EN 1993-1-8: 6.2.5
Effective area - influence of mesh size	0,10	-	
Friction coefficient - concrete	0,25	-	EN 1993-1-8
Friction coefficient in slip-resistance	0,30	-	EN 1993-1-8 tab 3.7
Limit plastic strain	0,05	-	EN 1993-1-5
Weld stress evaluation	Plastic redistribution		
Detailing	No		
Distance between bolts [d]	2,20	-	EN 1993-1-8: tab 3.3
Distance between bolts and edge [d]	1,20	-	EN 1993-1-8: tab 3.3
Concrete breakout resistance check	Both		EN 1992-4: 7.2.1.4 and 7.2.2.5
Use calculated a_b in bearing check.	Yes		EN 1993-1-8: tab 3.4
Cracked concrete	Yes		EN 1992-4
Local deformation check	No		CIDECT DG 1, 3 - 1.1
Local deformation limit	0,03	-	CIDECT DG 1, 3 - 1.1
Geometrical nonlinearity (GMNA)	Yes		Allow large deformations of hollow sections
Braced system	No		EN 1993-1-8: 5.2.2.5

10. Dimenzioniranje temelja samca

Dimenzije temelja: 3,0 m x 1,50 m x 1,0 m

Dopušteno naprezanje: $\sigma = 150 \text{ MPa}$

$$M_{sd} = 50,63 \text{ kNm}$$

$$N_{sd} = -166,55 \text{ kN}$$

$$h = 1,0 \text{ m}$$

$$a = \sqrt{\frac{P}{\sigma}} = \frac{166,55}{150} = 1,11 \text{ m} - \text{odabrano: } b=3,0 \text{ m, } a=1,50 \text{ m}$$

Maksimalno djelovanje na temelj:

$$N_{Ed'} = -166,55 \text{ kN} - \text{tlak}$$

Težina temelja:

$$N_t = 3,0 \cdot 1,50 \cdot 1,0 \cdot 25 = 112,50 \text{ kN}$$

$$N_{Ed} = N_t + N_{Ed'} = 166,55 + 112,50 = 279,05 \text{ kN}$$

Naprezanje ispod temelja:

$$\sigma_{1,2} \leq \sigma_{dop, tla} = 150 \frac{\text{kN}}{\text{m}^2}$$

$$\sigma_{1,2} \leq \frac{N_{Ed}}{A} \pm \frac{M_{Ed}}{W}$$

$$A = 3,0 \cdot 1,50 = 4,50 \text{ m}^2$$

$$W \leq \frac{b \cdot a^2}{6} = \frac{3,0 \cdot 1,5^2}{6} = 1,125 \text{ m}^3$$

$$\sigma_1 = 45,0 \frac{\text{kN}}{\text{m}^2} < 100 \frac{\text{kN}}{\text{m}^2}$$

$$\sigma_1 = 23,31 \frac{\text{kN}}{\text{m}^2} < 100 \frac{\text{kN}}{\text{m}^2}$$

11. Popis grafičkih priloga

Prilog 1: Tlocrt i plan pozicija prizemlja

Prilog 2: Tlocrt i plan pozicija 1. etaže

Prilog 3: Tlocrt i plan pozicija 2. etaže

Prilog 4: Tlocrt i plan pozicija krova

Prilog 5: Presjek kroz glavnu rešetku

Prilog 6: Radionički nacrt segmenta 1 glavne rešetke i velikog stupa

Prilog 7: Detalji A i B – Spoj velikog i malog stupa s temeljem

Prilog 8: Detalj C - Nastavak gornjeg pojasa bočne rešetke

Prilog 9: Detalj D – Nastavak donjeg pojasa bočne rešetke

Prilog 10: Detalj E - Nastavak ispune bočne rešetke

Prilog 11: Detalji F i G – Spoj donjeg/gornjeg pojasa bočne rešetke i ispuna

Prilog 12: Detalj H – Spoj stupa s gredama

Prilog 13: Detalj I – Nastavak gornjeg pojasa glavne rešetke

Prilog 14: Detalj J – Nastavak donjeg pojasa glavne rešetke

Prilog 15: Detalj K – Nastavak ispuna glavne rešetke

Prilog 16: Detalji L i M – Spoj gornjeg/donjeg pojasa glavne rešetke s ispunama

Prilog 17: Detalj N – Nastavak podrožnice

12. Literatura

- [1] Androić B., Dujmović D., Džeba I., Metalne konstrukcije 1, IGH Zagreb, 1994.
- [2] Androić B., Dujmović D., Džeba I., Čelične konstrukcije 1, IA Projektiranje, Zagreb, 2009.
- [3] Prof.dr.sc.Ivica Boko, Predavanja
- [4] HRN EN 1991-1-1:2008 Eurokod 1 --Djelovanja na konstrukcije --Dio 1-1: Opća djelovanja --Prostorne težine, vlastita težina i uporabna opterećenja za zgrade (EN 1991-1-1:2002)Eurocode 1 --Actions on structures --Part 1-1: General actions --Densities, self-weight, imposed loadsfor buildings (EN 1991-1-1:2002)
- [5] HRN EN 1991-1-3:2008 Eurokod 1 --Djelovanja na konstrukcije --Dio 1-3: Opća djelovanja --Opterećenje snijegom (EN 1991-1-3:2003)Eurocode 1 --Actions on structures --Part 1-3: General actions --Snow load (EN 1991-1-3:2003)
- [6] HRN EN 1991-1-4:2008 Eurokod 1 --Djelovanja na konstrukcije --Dio 1-4: Opća djelovanja --Djelovanja vjetra (EN 1991-1-4:2005)Eurocode 1 --Actions on structures --Part 1-4: General actions --Wind action (EN 1991-1-4:2005)
- [7] HRN EN 1991-1-5:2008 Eurokod 1 --Djelovanja na konstrukcije --Dio 1-5: Opća djelovanja --Toplinska djelovanja (EN 1991-1-5:2003)Eurocode 1 --Actions on structures --Part 1-5: General actions --Thermal actions (EN 1991-1-5:2003)
- [8] HRN EN 1993-1-1:2008 Eurokod 3 --Projektiranje čeličnih konstrukcija --Dio 1-1: Opća pravila i pravila za zgrade (EN 1993-1-1:2005+AC:2006)Eurocode 3 --Design of steel structures --Part 1-1: General rules and rules for buildings (EN 1993-1-1:2005+AC:2006)
- [9] HRN EN 1993-1-8:2008 Eurokod 3 --Projektiranje čeličnih konstrukcija --Dio 1-8: Projektiranje priključaka (EN 1993-1-8:2005+AC:2005)Eurocode 3 --Design of steel structures --Part 1-8: Design of joints (EN 1993-1-8:2005+AC:2005)

TLOCRT I PLAN POZICIJA PRIZEMLJA
MJ 1:200

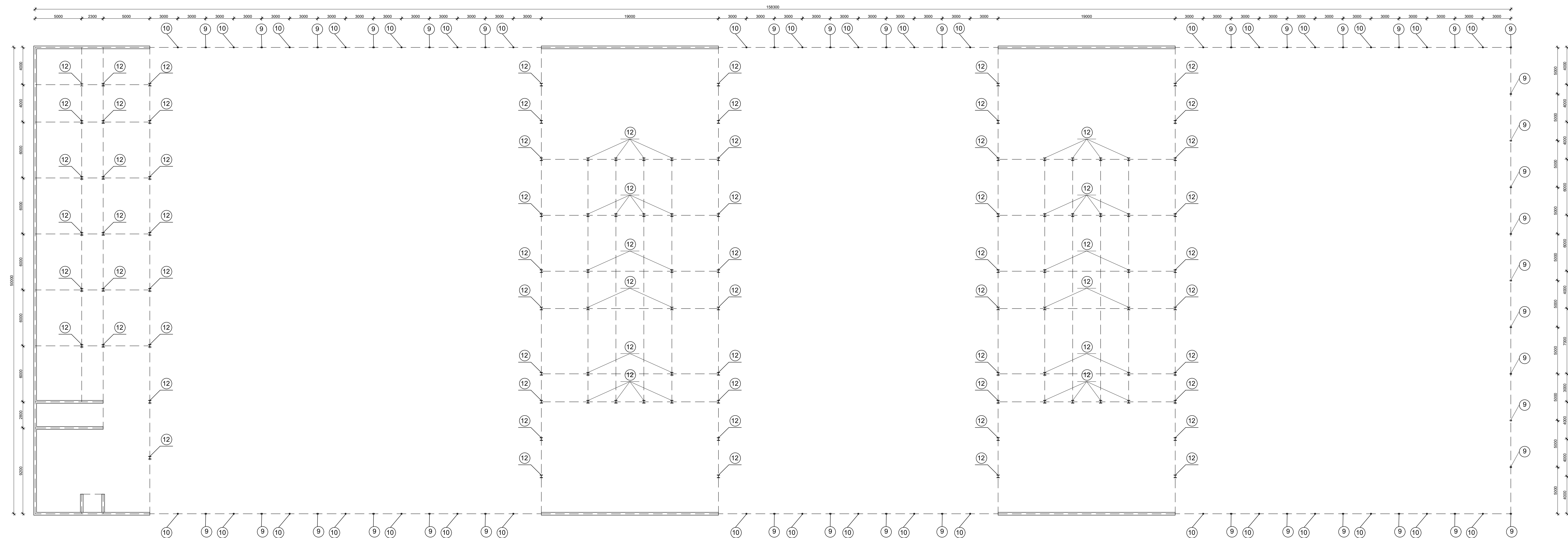

PRIKAZ I OPIS POZICIJA		
POZICIJA	PROFIL	NAZIV
9	CFRHS 180/120/10	veliki stup
10	CFRHS 120/120/6	maili stup
12	HEM280	unutarnji stup

<p>SVEUČILIŠTE U SPLITU, FAKULTET GRAĐEVINARSTVA, ARHITEKTURE I INŽENJERINGA</p> <p>FAKULTET GRAĐEVINARSTVA, ARHITEKTURE I INŽENJERINGA KATEDRA ZA METALNE I DRVENE KONSTRUKCIJE 21000 SPLIT, MATICE HRVATIKE 15</p>	DIPLOMSKI RAD	
	PROGRAM:	Projekt čelične konstrukcije "Zeleni inkubator"
	STUDENT:	Mia Blažević, 758
	MENTOR:	prof. dr. sc. Ivica Boko
SADRŽAJ	Tlocrt i plan pozicija prizemlja	MJERILO 1:200
DATUM	rujan 2020.	PRILOG 1

TLOCRT I PLAN POZICIJA 1.ETAŽE
MJ 1:200

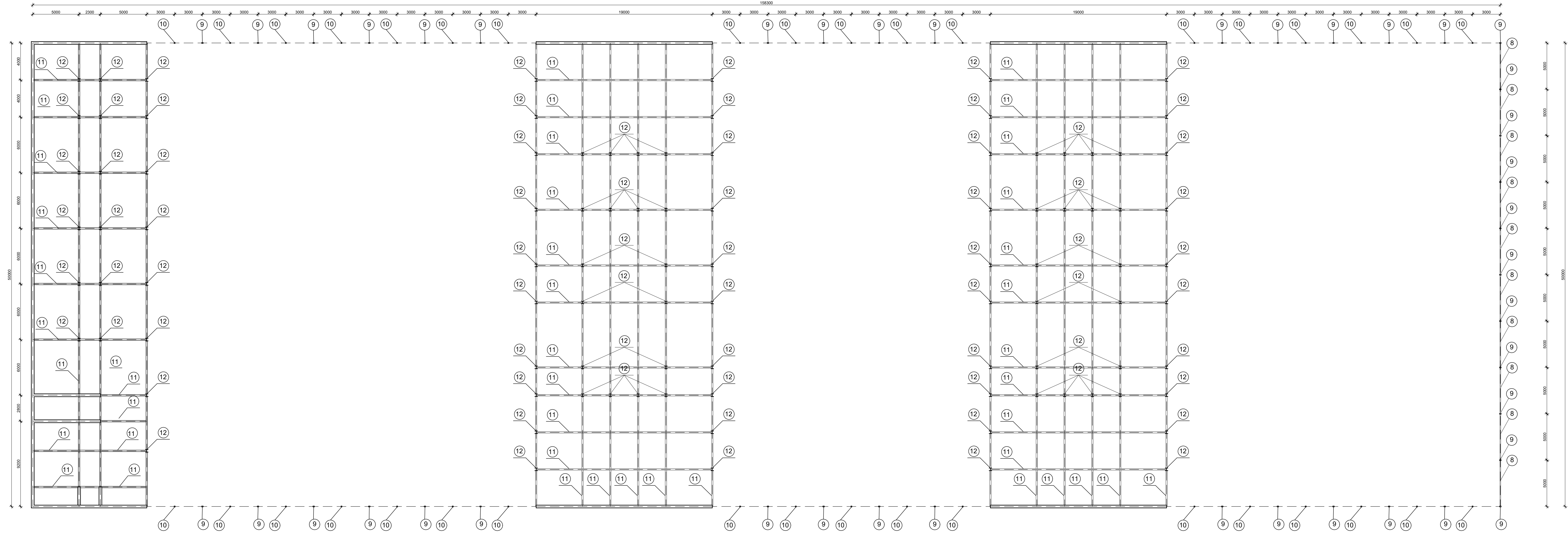

PRIKAZ I OPIS POZICIJA		
POZICIJA	PROFIL	NAZIV
8	CFRHS 80/60/5	vanjske grede
9	CFRHS 180/120/10	veliki stup
10	CFRHS 120/100/6	mali stup
11	HEB160	unutarnje grede
12	HEM280	unutarnji stup

<p>SVEUČILIŠTE U SPLITU, FAKULTET GRAĐEVINARSTVA, ARHITEKTURE I INŽENJERINGA</p> <p>FAKULTET GRAĐEVINARSTVA, ARHITEKTURE I INŽENJERINGA KATEDRA ZA METALNE I DRVENE KONSTRUKCIJE 21000 SPLIT, MATICE HRVATIKE 15</p>	DIPLOMSKI RAD	
	PROGRAM:	Projekt čelične konstrukcije "Zeleni inkubator"
	STUDENT:	Mia Blažević, 758
	MENTOR:	prof. dr. sc. Ivica Boko
SADRŽAJ	Tlocrt i plan pozicija 1. etaže	MJERILO 1:200
DATUM	rujan 2020.	PRILOG 2

TLOCRT I PLAN POZICIJA 2.ETAŽE MJ 1:200

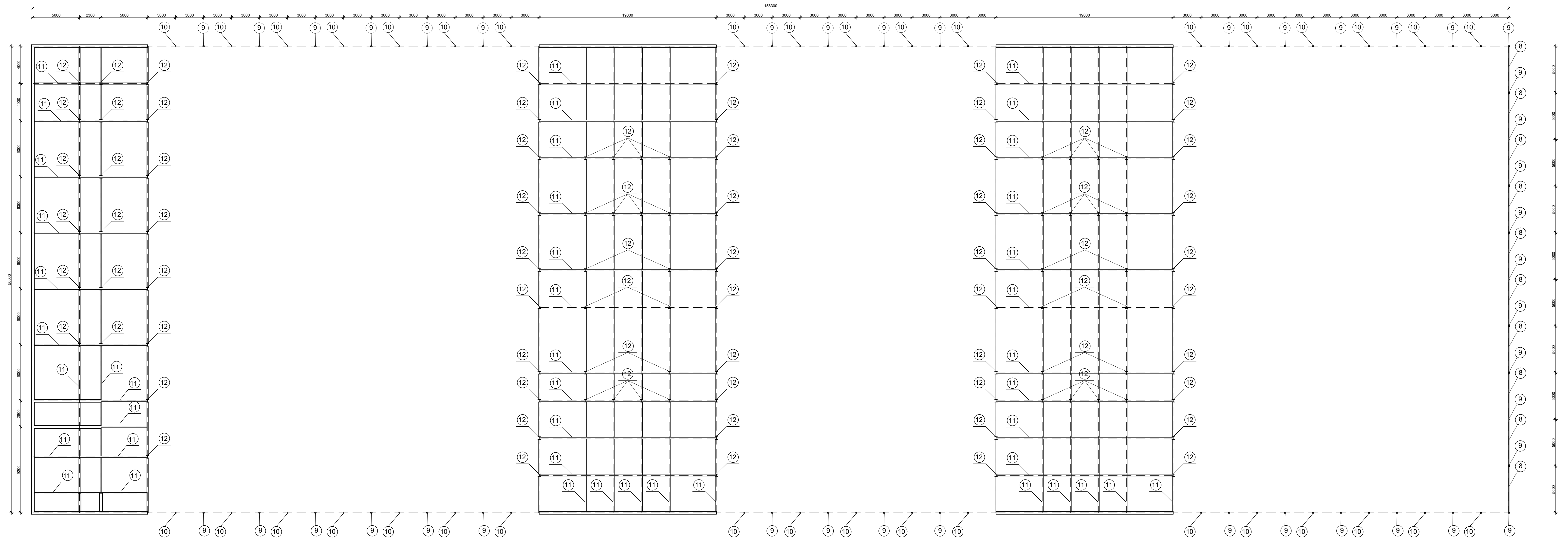

PRIKAZ I OPIS POZICIJA		
POZICIJA	PROFIL	NAZIV
8	CFRHS 80/60/5	vanjske grede
9	CFRHS 180/120/10	veliki stup
10	CFRHS 120/100/6	mali stup
11	HEB160	unutarnje grede
12	HEM280	unutarnji stup

 <p>SVEUČILIŠTE U SPLITU, FAKULTET GRAĐEVINARSTVA, ARHITEKTURE I INŽENJERINGA</p> <p>FAKULTET GRAĐEVINARSTVA, ARHITEKTURE I INŽENJERINGA KATEDRA ZA METALNE I DRVENE KONSTRUKCIJE 21000 SPLIT, MATICE HRVATIKE 15</p>	DIPLOMSKI RAD	
	PROGRAM:	Projekt čelične konstrukcije "Zeleni inkubator"
	STUDENT:	Mia Blažević, 758
	MENTOR:	prof. dr. sc. Ivica Boko
SADRŽAJ	Tlocrt i plan pozicija 2. etaže	MJERILO 1:200
DATUM	rujan 2020.	PRILOG 3

TLOCRT I PLAN POZICIJA KROVA MJ 1:200

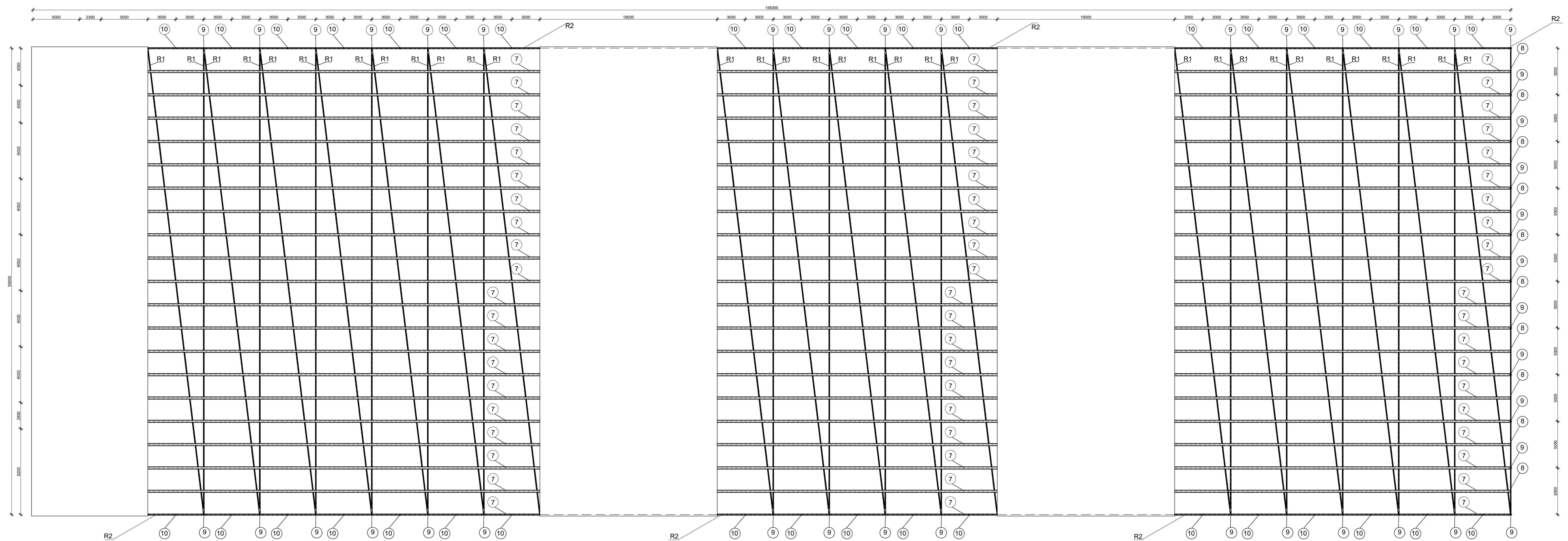

PRIKAZ I OPIS POZICIJA			
	POZICIJA	PROFIL	NAZIV
R1	1	CFRHS 200/100/10	gornji pojas glavne rešetke
	2	CFRHS 200/100/12.5	donji pojas glavne rešetke
	3	CFRHS 140/80/6	ispune glavne rešetke
R2	4	CFRHS 200/100/10	gornji pojas bočne rešetke
	5	CFRHS 200/100/12.5	donji pojas bočne rešetke
	6	CFRHS 100/60/6	ispune bočne rešetke
	7	HEB240	krovne podrožnice
	8	CFRHS 80/60/5	vanjske grede
	9	CFRHS 180/120/10	veliki stup
	10	CFRHS 120/120/6	mali stup



DIPLOMSKI RAD		
PROGRAM:	Projekt čelične konstrukcije "Zeleni inkubator"	
STUDENT:	Mia Blažević, 758	MENTOR: prof. dr. sc. Ivica Boko
SADRŽAJ	Tlocrt i plan pozicija krova	MJERILO 1:200
DATUM	rujan 2020.	PRILOG 4

PRESJEK KROZ GLAVNU REŠETKU

MJ 1:100

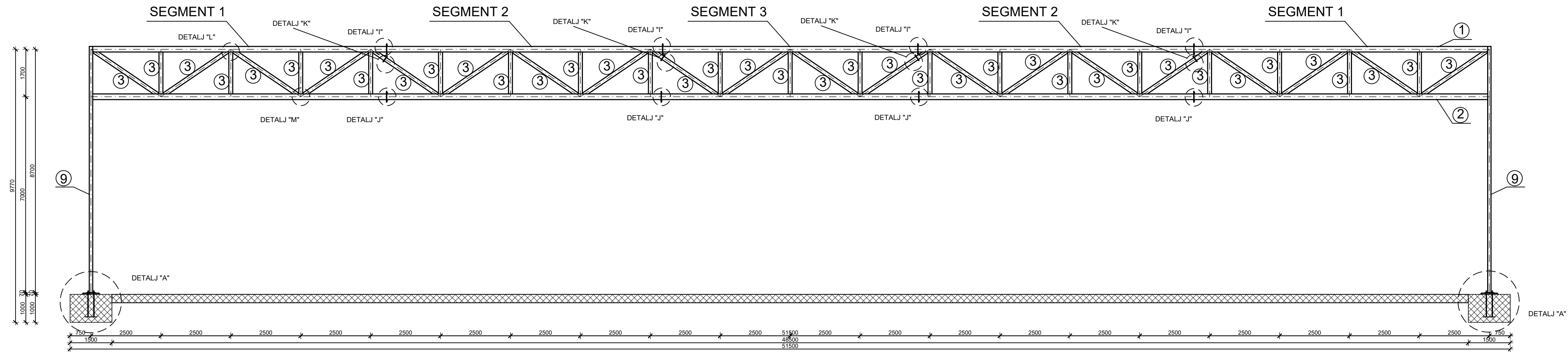

PRIKAZ I OPIS POZICIJA			
	POZICIJA	PROFIL	NAZIV
R1	1	CFRHS 200/100/10	gornji pojas glavne rešetke
	2	CFRHS 200/100/12.5	donji pojas glavne rešetke
	3	CFRHS 140/80/6	ispune glavne rešetke
	9	CFRHS 180/120/10	veliki stup



DIPLOMSKI RAD		
PROGRAM:	Projekt čelične konstrukcije "Zeleni inkubator"	
STUDENT:	Mia Blažević, 758	MENTOR: prof. dr. sc. Ivica Boko
SADRŽAJ	Presjek kroz glavnu rešetku	MJERILO 1:100
DATUM	rujan 2020.	PRILOG 5

RADIONIČKI NACRT SEGMENTA 1 I VELIKOG STUPA

MJ 1:50

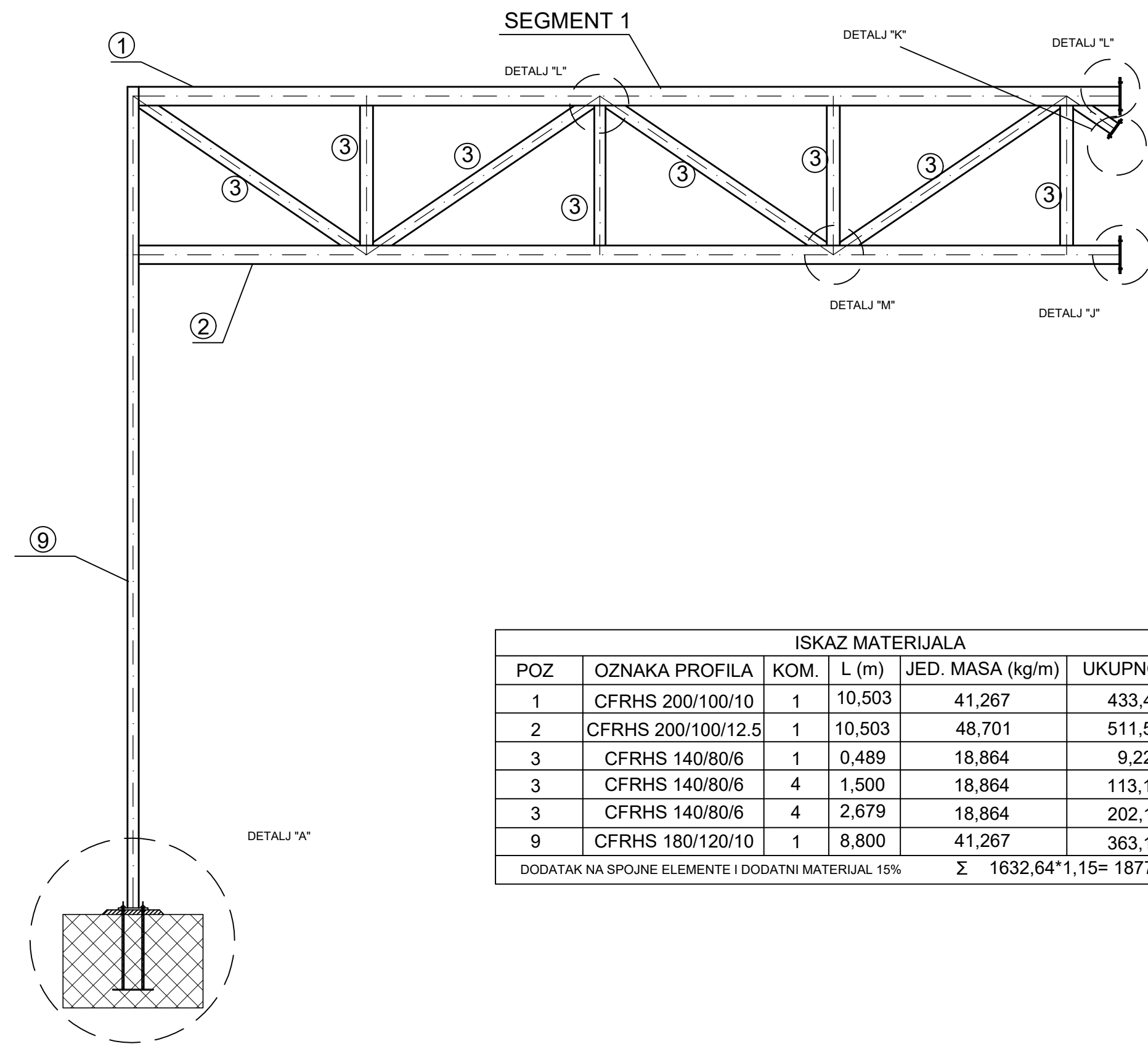

ISKAZ MATERIJALA					
POZ	OZNAKA PROFILA	KOM.	L (m)	JED. MASA (kg/m)	UKUPNO (kg)
1	CFRHS 200/100/10	1	10,503	41,267	433,427
2	CFRHS 200/100/12.5	1	10,503	48,701	511,507
3	CFRHS 140/80/6	1	0,489	18,864	9,224
3	CFRHS 140/80/6	4	1,500	18,864	113,184
3	CFRHS 140/80/6	4	2,679	18,864	202,148
9	CFRHS 180/120/10	1	8,800	41,267	363,150
DODATAK NA SPOJNE ELEMENTE I DODATNI MATERIJAL 15%				Σ	1632,64*1,15= 1877,536 kg

① CFRHS 200/100/10, L=10 503 mm, kom. 1	
② CFRHS 200/100/12.5, L=10 503 mm, kom. 1	
⑨ CFRHS 180/120/10, L=8800 mm, kom. 1	
③ CFRHS 140/80/6, L=1500 mm, kom. 4	③ CFRHS 140/80/6, L=2679 mm, kom. 4
③ CFRHS 140/80/6, L=489 mm, kom. 1	

DIPLOMSKI RAD		
PROGRAM: Projekt čelične konstrukcije "Zeleni inkubator"		
STUDENT: Mia Blažević, 758	MENTOR: prof. dr. sc. Ivica Boko	
SADRŽAJ: Radionički nacrt segmenta 1 i velikog stupa	MJERILO: 1:50	
DATUM: rujan 2020.	PRILOG: 6	

UCA
SVEUČILIŠTE U SPLITU,
FAKULTET GRAĐEVINARSTVA,
ARHITEKTURE I GEODEZIJE
FAKULTET GRAĐEVINARSTVA, ARHITEKTURE I
 GEODEZIJE
 KATEDRA ZA METALNE I DRVENE KONSTRUKCIJE
 21000 SPLIT, MATICE HRVATSKE 15

Detalji A i B - SPOJEVI VELIKOG I MALOG STUPA S TEMELJEM

MJ. 1:20

Detalj A - Spoj velikog stupa s temeljem

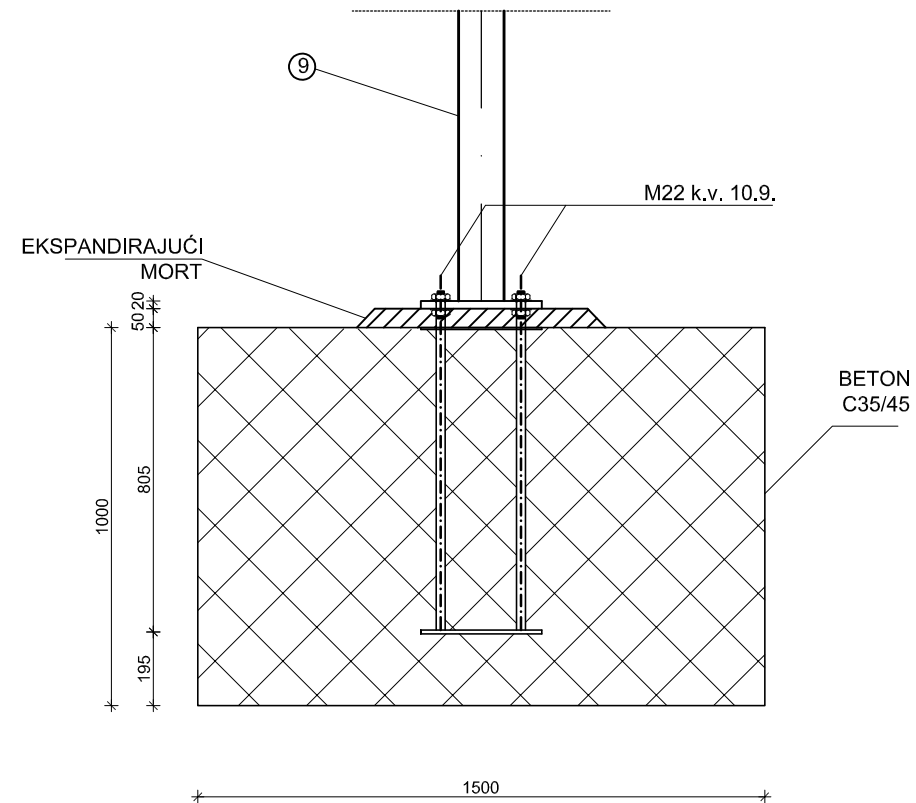

Detalj B - Spoj malog stupa s temeljem

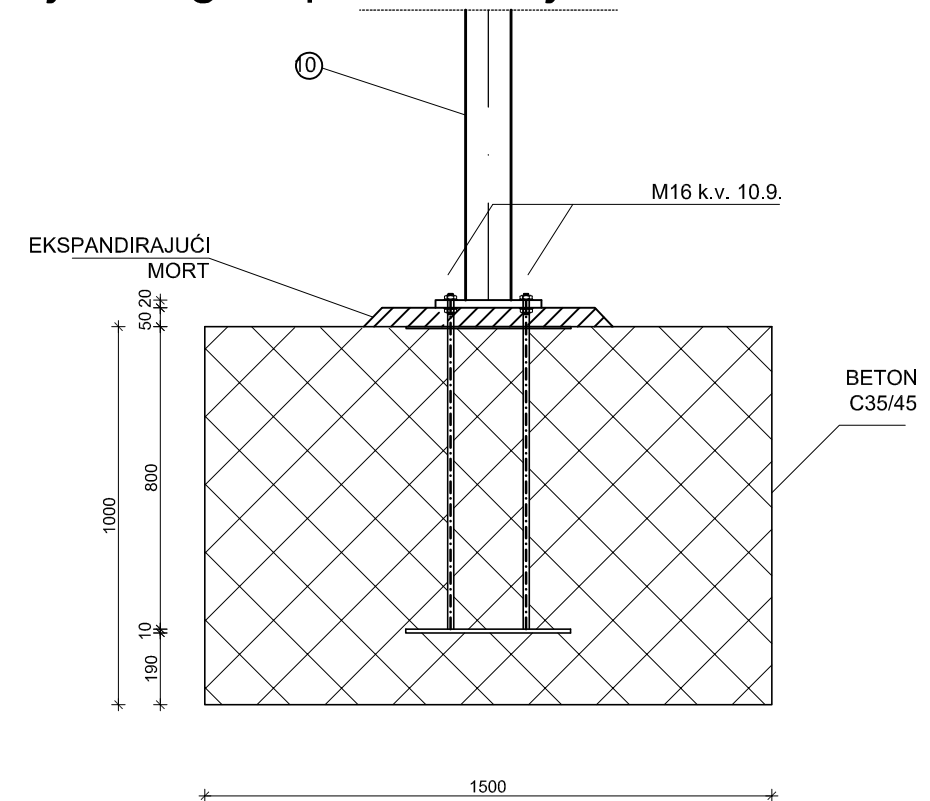

P1 320/420/20 S-335 kom. 1 po stupu
M 1: 10

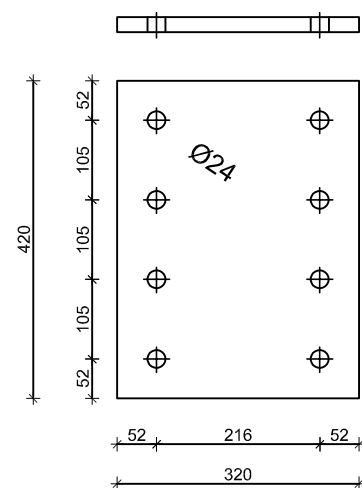

P1a 320/420/5 S-335 kom. 1 po stupu
M 1: 10

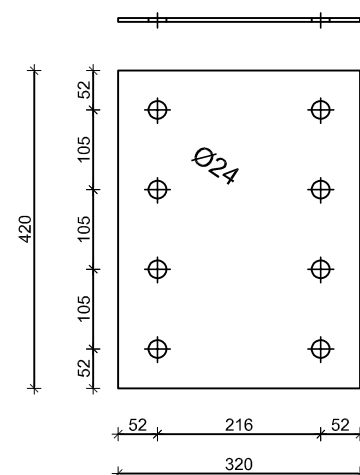

P2 280/200/20 S-335 kom. 1 po stupu
M 1: 10

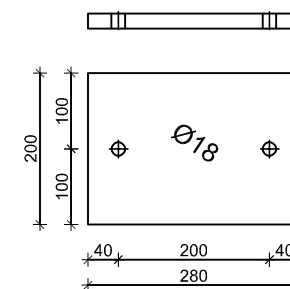

P2a 280/200/5 S-335 kom. 1 po stupu
M 1: 10

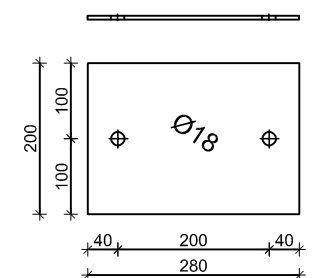

 SVEUČILIŠTE U SPLITU, FAKULTET GRAĐEVINARSTVA, ARHITEKTURE I GEODEZIJE <small>FAKULTET GRAĐEVINARSTVA, ARHITEKTURE I GEODEZIJE KATEDRA ZA METALNE I DRVENE KONSTRUKCIJE 21000 SPLIT, MATICE HRVATSKE 15</small>	DIPLOMSKI RAD	
	PROGRAM: Projekt čelične konstrukcije "Zeleni inkubator"	
	STUDENT: Mia Blažević, 758	MENTOR: prof. dr. sc. Ivica Boko
	SADRŽAJ Detalji A i B - Spojevi velikog i malog stupa s temeljem	MJERILO 1:20
DATUM	rujan 2020.	PRILOG 7

Detalj D - Nastavak donjeg pojasa bočne rešetke

MJ. 1:10

Tlocrt

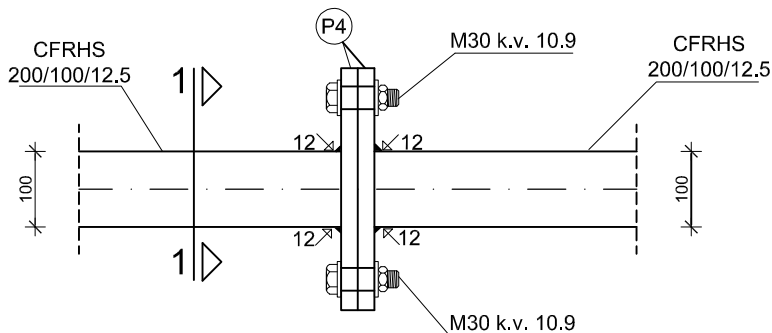

Pogled

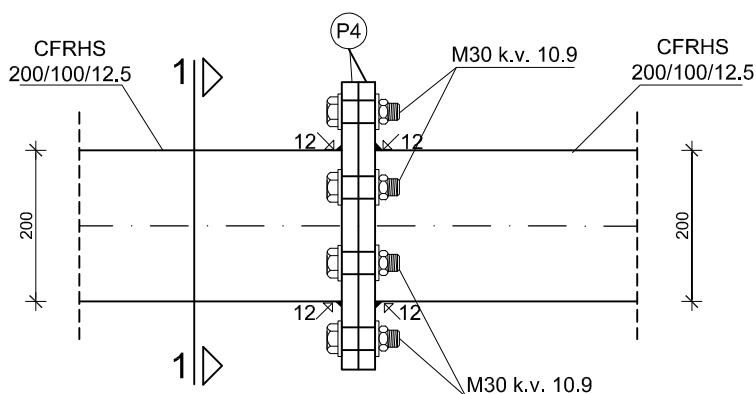

Presjek 1-1

(P4) 320/380/22 S 355 kom. 2 po nastavku

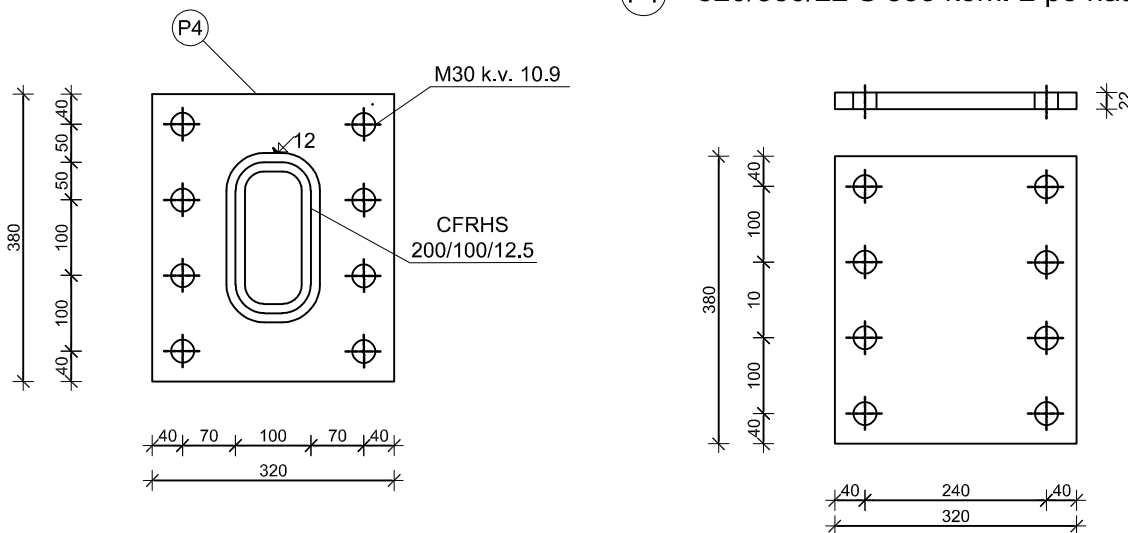

SVEUČILIŠTE U SPLITU,
FAKULTET GRAĐEVINARSTVA,
ARHITEKTURE I GEODEZIJE

FAKULTET GRAĐEVINARSTVA, ARHITEKTURE I
GEODEZIJE
KATEDRA ZA METALNE I DRVENE KONSTRUKCIJE
21000 SPLIT, MATICE HRVATSKE 15

DIPLOMSKI RAD

PROGRAM:

Projekt čelične konstrukcije "Zeleni inkubator"

STUDENT:

Mia Blažević, 758

MENTOR:

prof. dr. sc. Ivica Boko

SADRŽAJ

Detalj D - Nastavak donjeg pojasa
bočne rešetke

MJERILO

1:10

DATUM

rujan 2020.

PRILOG

9

Detalj E - Nastavak ispune bočne rešetke

MJ. 1:10

Tlocrt

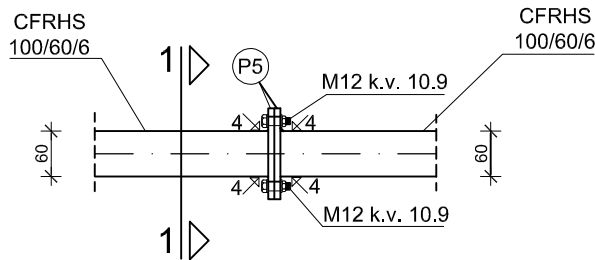

Pogled

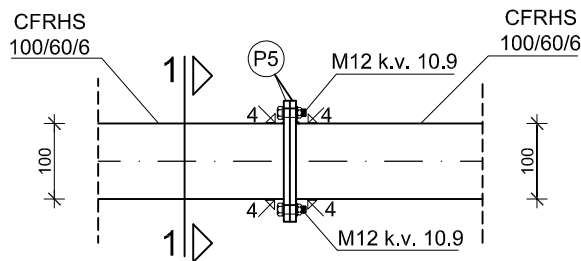

Presjek 1-1

Ⓟ 120/160/8 S 355 kom. 2 po nastavku

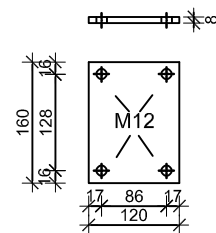
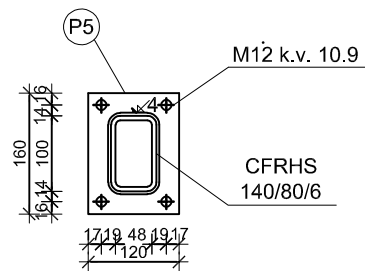

SVEUČILIŠTE U SPLITU,
FAKULTET GRAĐEVINARSTVA,
ARHITEKTURE I GEODEZIJE

FAKULTET GRAĐEVINARSTVA, ARHITEKTURE I
GEODEZIJE
KATEDRA ZA METALNE I DRVENE KONSTRUKCIJE
21000 SPLIT, MATICE HRVATSKE 15

DIPLOMSKI RAD

PROGRAM:

Projekt čelične konstrukcije "Zeleni inkubator"

STUDENT:

Mia Blažević, 758

MENTOR:

prof. dr. sc. Ivica Boko

SADRŽAJ

Detalj E - Nastavak ispune bočne
rešetke

MJERILO 1:10

DATUM

rujan 2020.

PRILOG

10

Detalj G - Presjek

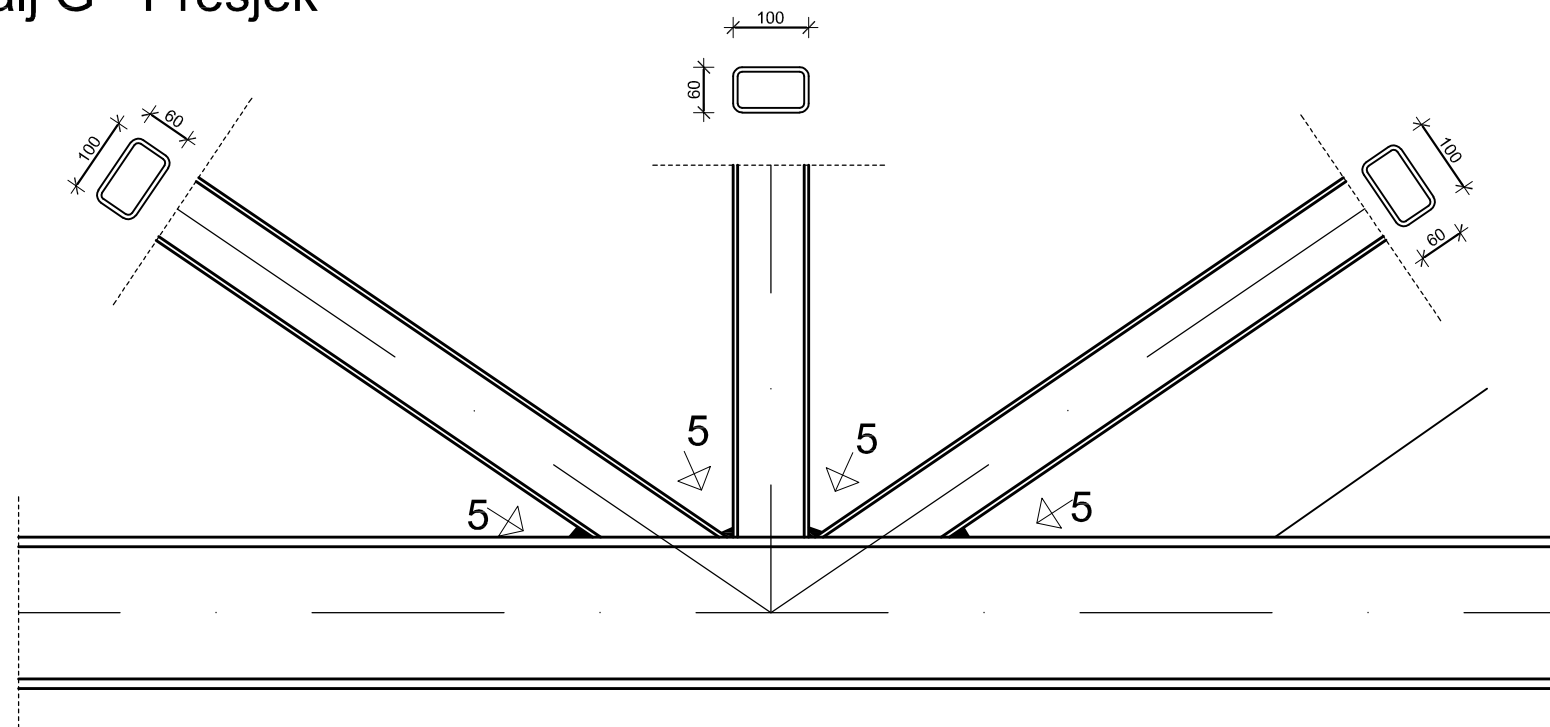

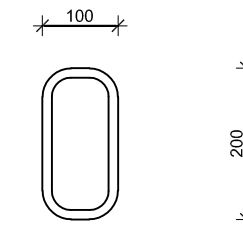

Detalji F i G - SPOJ GORNJEG/DONJEG POJASA
BOČNE REŠETKE S ISPUNAMA
MJ. 1:10

5

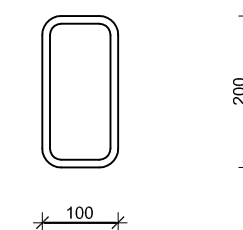
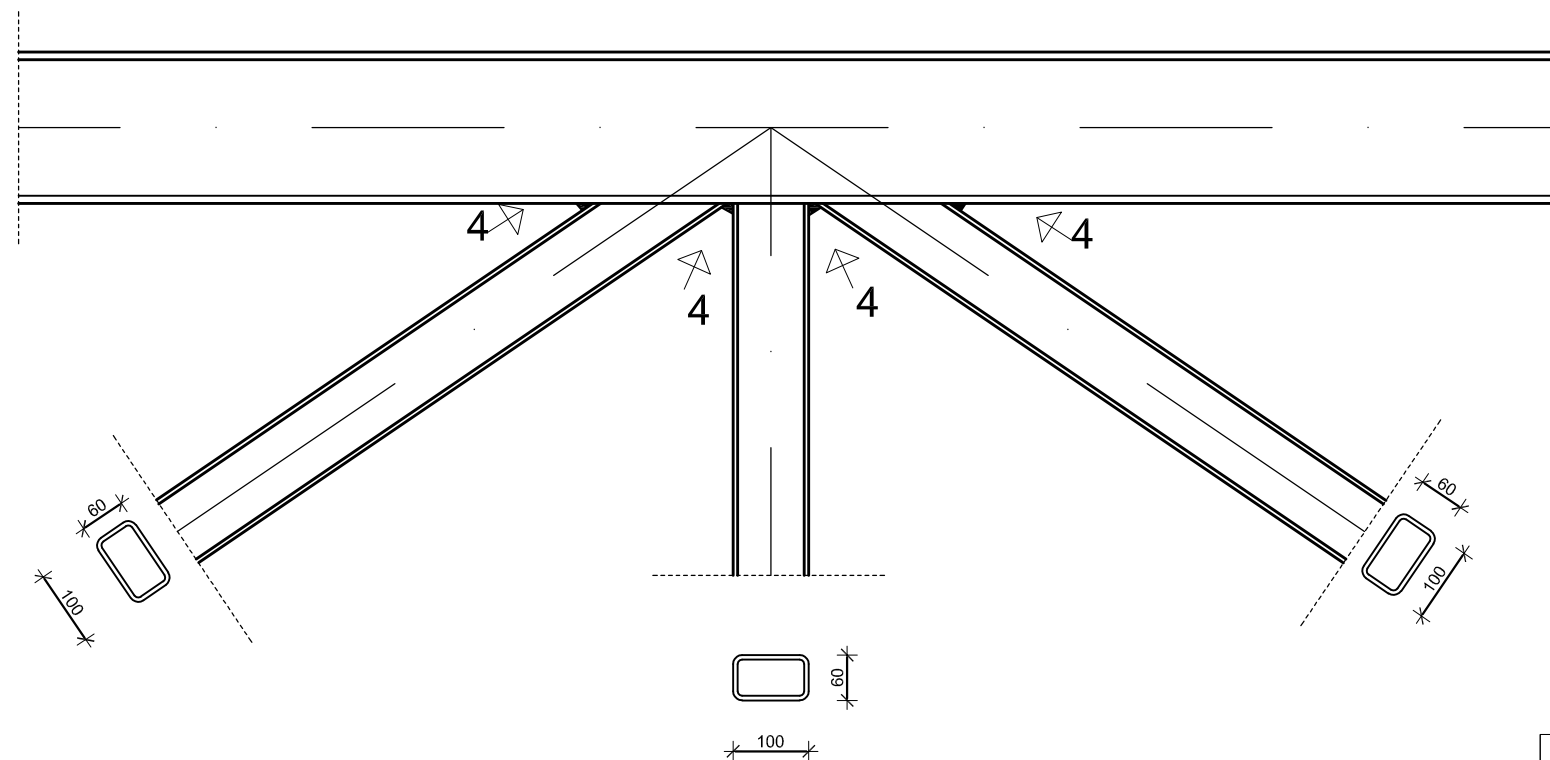

Detalj F - Presjek



 SVEUČILIŠTE U SPLITU, FAKULTET GRAĐEVINARSTVA, ARHITEKTURE I GEODEZIJE <small>FAKULTET GRAĐEVINARSTVA, ARHITEKTURE I GEODEZIJE KATEDRA ZA METALNE I DRVENE KONSTRUKCIJE 21000 SPLIT, MATICE HRVATSKE 15</small>	DIPLOMSKI RAD	
	PROGRAM: Projekt čelične konstrukcije "Zeleni inkubator"	
	STUDENT: Mia Blažević, 758	MENTOR: prof. dr. sc. Ivica Boko
	SADRŽAJ Detalji F i G - Spoj gornjeg/donjeg pojasa bočne rešetke s ispunama	MJERILO 1:10
	DATUM rujan 2020.	PRILOG 11

Detalj H - SPOJ STUPA SA GREDAMA

Presjek 1-1

MJ. 1:10

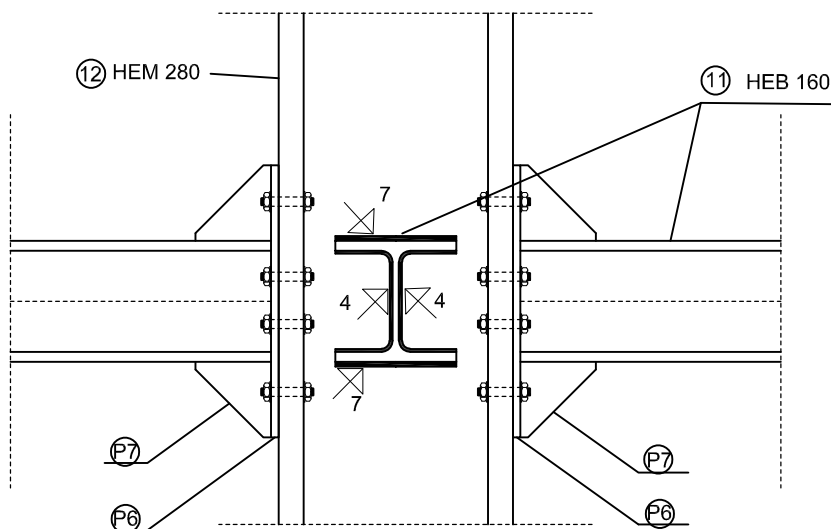

Svi vijci - M12 kv.10.9.

Tlocrt

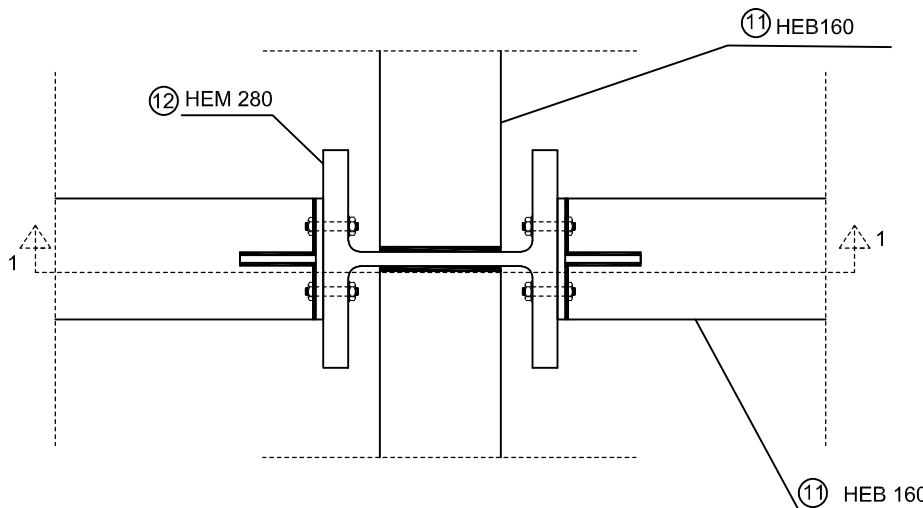

Ⓟ 360/160/10, 2 kom po stupu

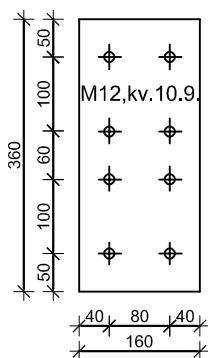

Ⓟ, 2 kom.po stupu

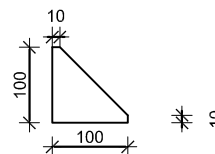

SVEUČILIŠTE U SPLITU,
FAKULTET GRAĐEVINARSTVA,
ARHITEKTURE I GEODEZIJE

FAKULTET GRAĐEVINARSTVA, ARHITEKTURE I
GEODEZIJE
KATEDRA ZA METALNE I DRVENE KONSTRUKCIJE
21000 SPLIT, MATICE HRVATSKE 15

DIPLOMSKI RAD

PROGRAM:

Projekt čelične konstrukcije "Zeleni inkubator"

STUDENT:

Mia Blažević, 758

MENTOR:

prof. dr. sc. Ivica Boko

SADRŽAJ

Detalj H - Spoj stupa s gredama

MJERILO 1:10

DATUM

rujan 2020.

PRILOG

12

Detalj I - Nastavak gornjeg pojasa glavne rešetke

MJ. 1:10

Tlocrt

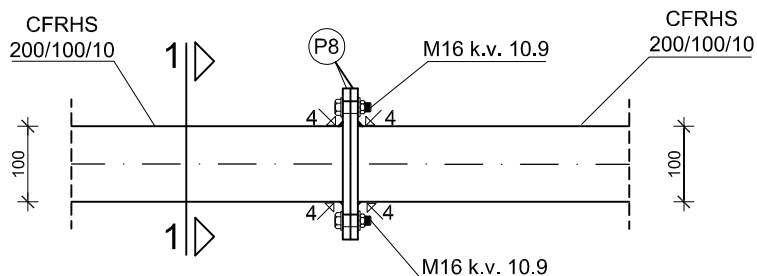

Pogled

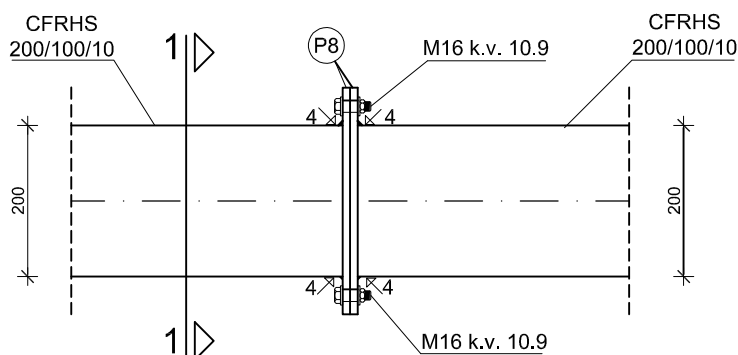

Presjek 1-1

Ⓟ 200/300/10 S 355 kom. 2 po nastavku

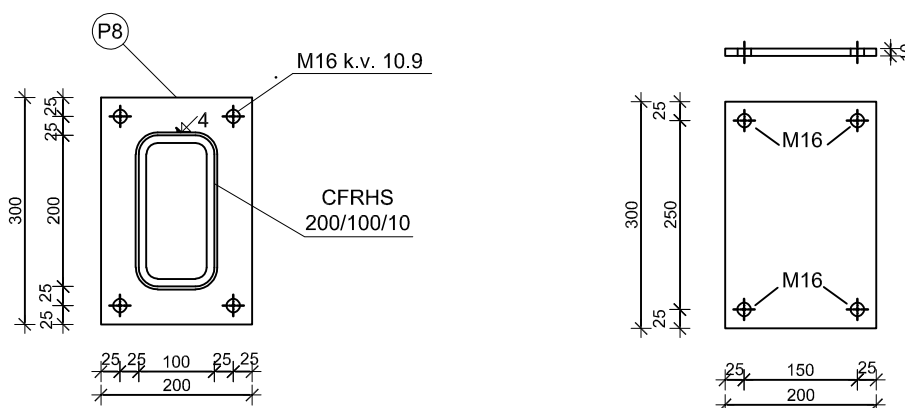

SVEUČILIŠTE U SPLITU,
FAKULTET GRAĐEVINARSTVA,
ARHITEKTURE I GEODEZIJE

FAKULTET GRAĐEVINARSTVA, ARHITEKTURE I
GEODEZIJE
KATEDRA ZA METALNE I DRVENE KONSTRUKCIJE
21000 SPLIT, MATICE HRVATSKE 15

DIPLOMSKI RAD

PROGRAM:

Projekt čelične konstrukcije "Zeleni inkubator"

STUDENT:

Mia Blažević, 758

MENTOR:

prof. dr. sc. Ivica Boko

SADRŽAJ

Detalj I - Nastavak gornjeg pojasa
glavne rešetke

MJERILO

1:10

DATUM

rujan 2020.

PRILOG

13

Detalj J - Nastavak donjeg pojasa glavne rešetke

MJ. 1:10

Tlocrt

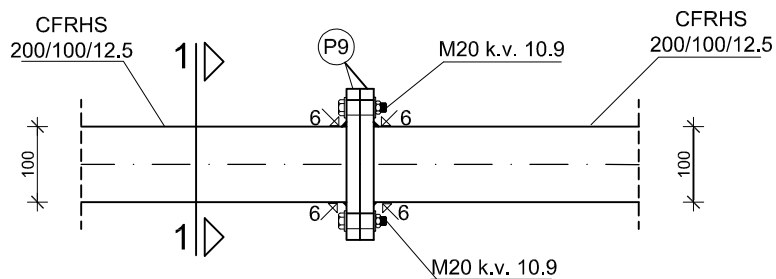

Pogled

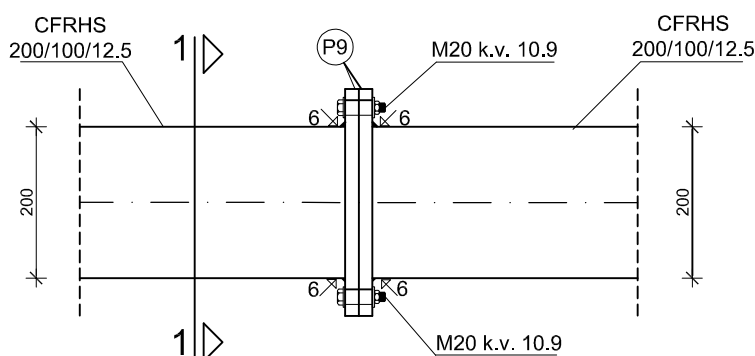

Presjek 1-1

⊙ P9 200/300/18 S 355 kom. 2 po nastavku

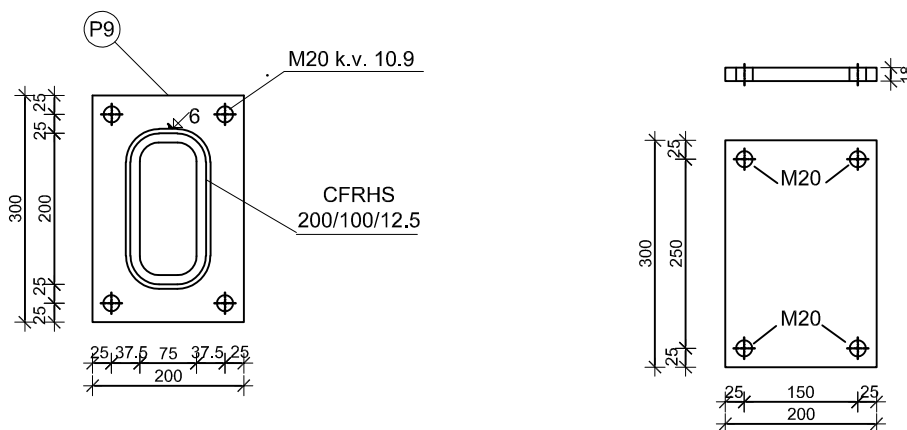

SVEUČILIŠTE U SPLITU,
FAKULTET GRAĐEVINARSTVA,
ARHITEKTURE I GEODEZIJE

FAKULTET GRAĐEVINARSTVA, ARHITEKTURE I
GEODEZIJE
KATEDRA ZA METALNE I DRVENE KONSTRUKCIJE
21000 SPLIT, MATICE HRVATSKE 15

DIPLOMSKI RAD

PROGRAM:

Projekt čelične konstrukcije "Zeleni inkubator"

STUDENT:

Mia Blažević, 758

MENTOR:

prof. dr. sc. Ivica Boko

SADRŽAJ

Detalj J - Nastavak donjeg pojasa
glavne rešetke

MJERILO

1:10

DATUM

rujan 2020.

PRILOG

14

Detalj K - Nastavak ispune glavne rešetke

MJ. 1:10

Tlocrt

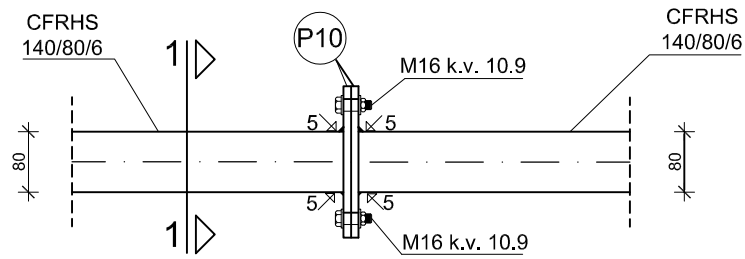

Pogled

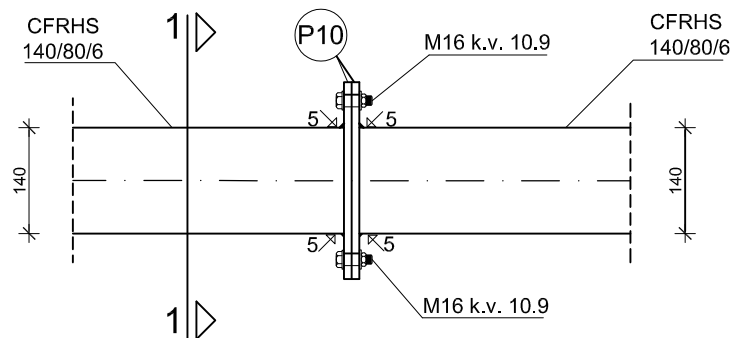

Presjek 1-1

P10 200/260/10 S 355 kom. 2 po nastavku

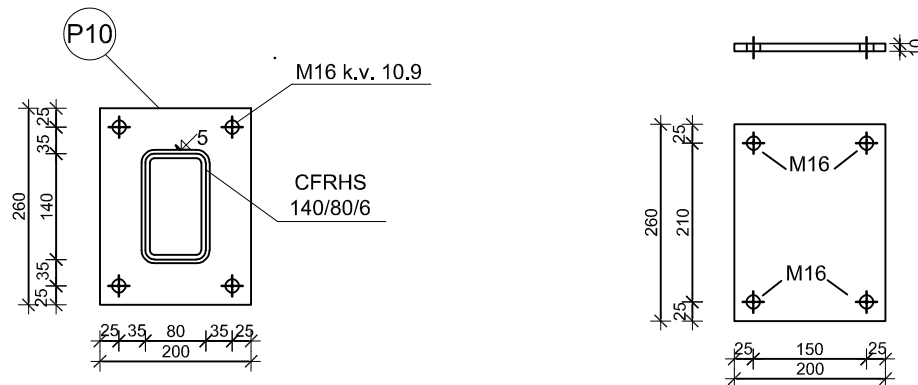

SVEUČILIŠTE U SPLITU,
FAKULTET GRAĐEVINARSTVA,
ARHITEKTURE I GEODEZIJE

FAKULTET GRAĐEVINARSTVA, ARHITEKTURE I
 GEODEZIJE
 KATEDRA ZA METALNE I DRVENE KONSTRUKCIJE
 21000 SPLIT, MATICE HRVATSKE 15

DIPLOMSKI RAD

PROGRAM:

Projekt čelične konstrukcije "Zeleni inkubator"

STUDENT:

Mia Blažević, 758

MENTOR:

prof. dr. sc. Ivica Boko

SADRŽAJ

Detalj K - Nastavak ispune glavne
 rešetke

MJERILO 1:10

DATUM

rujan 2020.

PRILOG

15

Detalj L - Presjek

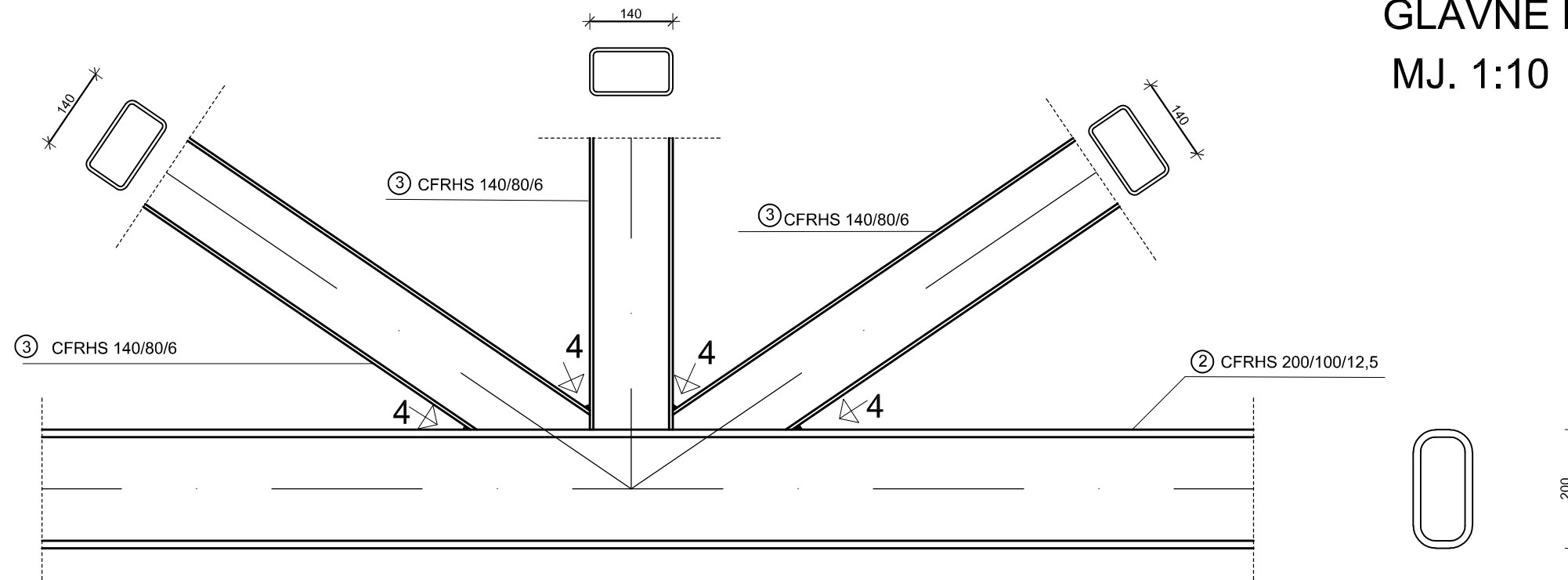

Detalji L i M - SPOJ GORNJEG/DONJEG POJASA GLAVNE REŠETKE S ISPUNAMA MJ. 1:10

Detalj M - Presjek

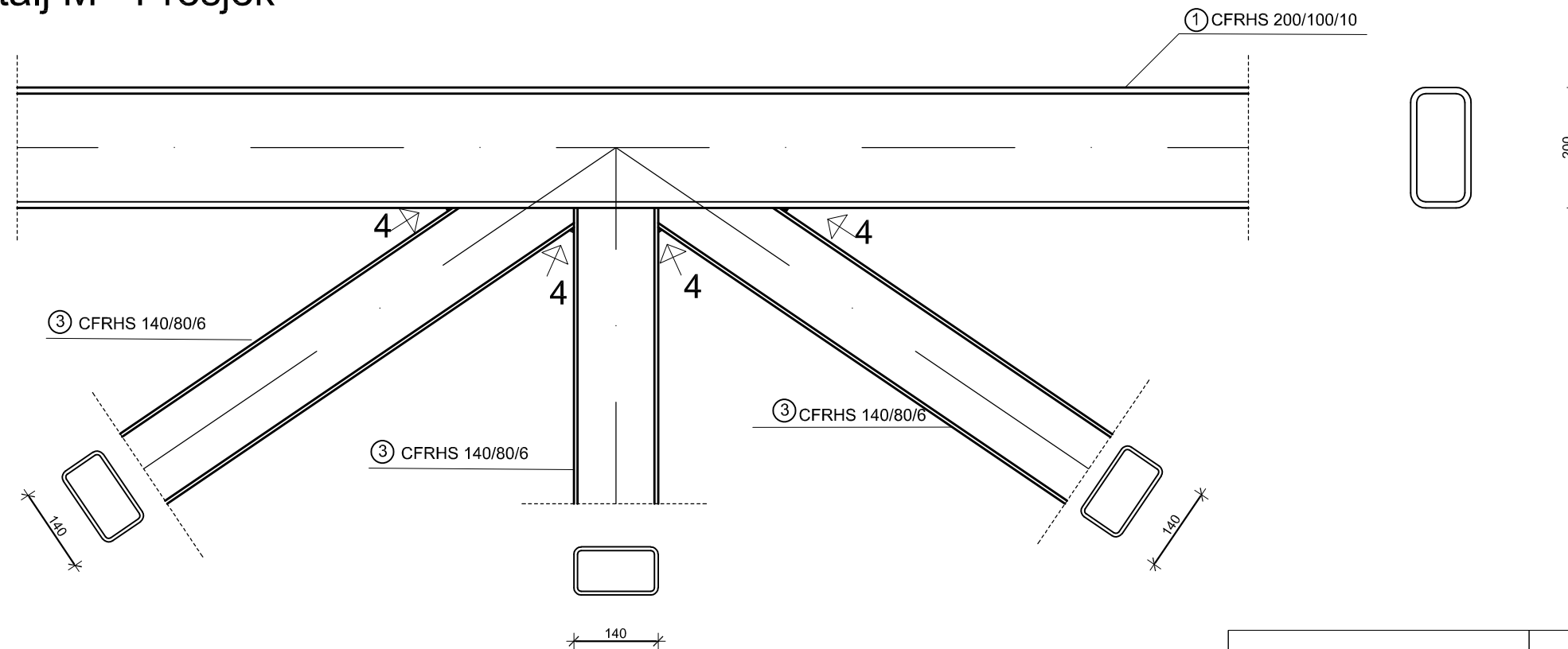

 SVEUČILIŠTE U SPLITU, FAKULTET GRAĐEVINARSTVA, ARHITEKTURE I GEODEZIJE <small>FAKULTET GRAĐEVINARSTVA, ARHITEKTURE I GEODEZIJE KATEDRA ZA METALNE I DRVENE KONSTRUKCIJE 21000 SPLIT, MATICE HRVATSKE 15</small>	DIPLOMSKI RAD	
	PROGRAM: Projekt čelične konstrukcije "Zeleni inkubator"	
	STUDENT: Mia Blažević, 758	MENTOR: prof. dr. sc. Ivica Boko
	SADRŽAJ Detalji L i M - Spoj gornjeg/donjeg pojasa glavne rešetke s ispunama	MJERILO 1:10
DATUM	rujan 2020.	PRILOG 16

Detalj N - NASTAVAK PODROŽNICE

MJ. 1:10

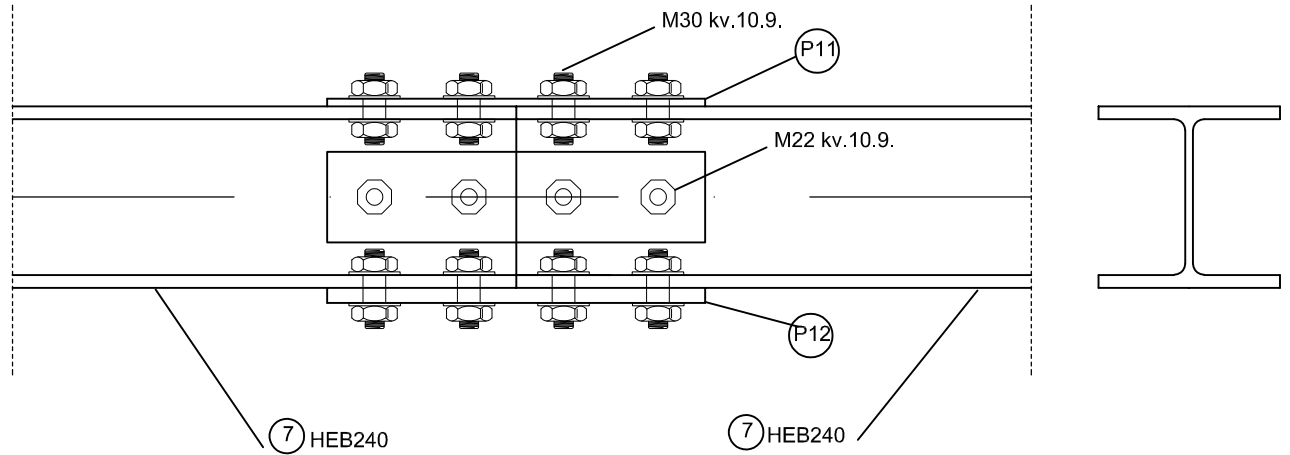

(P11) 360/160/10, 1 kom. po nastavku

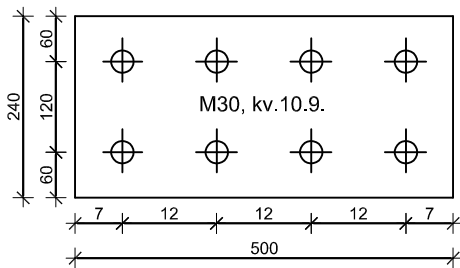

(P12) 360/160/20, 1 kom. po nastavku

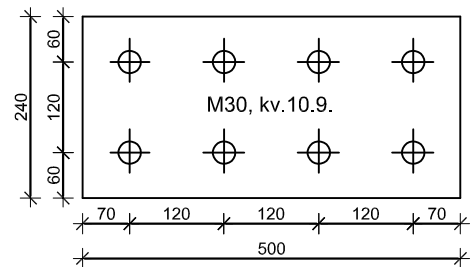

SVEUČILIŠTE U SPLITU,
FAKULTET GRAĐEVINARSTVA,
ARHITEKTURE I GEODEZIJE

FAKULTET GRAĐEVINARSTVA, ARHITEKTURE I
GEODEZIJE
KATEDRA ZA METALNE I DRVENE KONSTRUKCIJE
21000 SPLIT, MATICE HRVATSKE 15

DIPLOMSKI RAD

PROGRAM:

Projekt čelične konstrukcije "Zeleni inkubator"

STUDENT:

Mia Blažević, 758

MENTOR:

prof. dr. sc. Ivica Boko

SADRŽAJ

Detalj N - Nastavak podrožnice

MJERILO 1:10

DATUM

rujan 2020.

PRILOG

17