

Izrada projektnog rješenja krovne konstrukcije sportske hale u Plzenu, Češka

Perić, Antonio

Master's thesis / Diplomski rad

2020

Degree Grantor / Ustanova koja je dodijelila akademski / stručni stupanj:

University of Split, Faculty of Civil Engineering, Architecture and Geodesy / Sveučilište u Splitu, Fakultet građevinarstva, arhitekture i geodezije

Permanent link / Trajna poveznica: <https://urn.nsk.hr/urn:nbn:hr:123:245930>

Rights / Prava: [In copyright](#)/[Zaštićeno autorskim pravom.](#)

Download date / Datum preuzimanja: **2024-11-30**



Repository / Repozitorij:

[FCEAG Repository - Repository of the Faculty of Civil Engineering, Architecture and Geodesy, University of Split](#)



UNIVERSITY OF SPLIT



DIGITALNI AKADEMSKI ARHIVI I REPOZITORIJI

**SVEUČILIŠTE U SPLITU
FAKULTET GRAĐEVINARSTVA ARHITEKTURE I GEODEZIJE**

DIPLOMSKI RAD

Antonio Perić

Split, 2020.

**SVEUČILIŠTE U SPLITU
FAKULTET GRAĐEVINARSTVA ARHITEKTURE I GEODEZIJE**

Antonio Perić

**Izrada projektnog rješenja krovne konstrukcije
sportske hale u Plzenu, Češka**

Diplomski rad

Split, 2020.

Izrada projektnog rješenja krovne konstrukcije sportske hale u Plzenu, Češka

Sažetak:

Predmet ovog diplomskog rada je proračun čelične rešetkaste konstrukcije u sklopu projekta sportske hale smještene u gradu Plzen u Češkoj.

Konstruktivni sistem je sastavljen od čeličnih hladno valjanih profila i betonske jezgre. Materijal za izradu cijele krovne konstrukcije je čelik S275. Glavna krovna konstrukcija je izvedena u obliku ravne tropojasne zakrivljene prostorne rešetke postavljene na 10 stupova pravilno raspoređenih po obodu objekta. Na objekt su postavljeni krovne i bočne podrožnice, zabatni stupovi.

Projekt sadrži tehnički opis konstrukcije, analizu opterećenja na konstrukciju, proračun reznih sila, dimenzioniranje konstruktivnih elemenata, proračun spojeva i karakteristične građevinske nacрте.

Ključne riječi:

Rešetkasta konstrukcija, projekt, tropojasna rešetka, podrožnice, bočne podrožnice, zabatni stupovi, rezne sile, tehnički opis

Development of a design solution for the roof structure of a sports hall in Plzen, Czech Republic

Abstract:

Subject of this Master thesis is the calculation of a steel truss structure within the project of a sports hall located in the city of Plzen in the Czech Republic.

Structural system is composed of cold formed steel profiles and a concrete core. Material for the entire roof structure is steel S275. Main roof structure is made in the form of a flat three-belt curved 3D truss placed on 10 columns properly distributed around the perimeter of the building. Purlins, sheathing rails and gable columns have been installed on the building.

The project contains a technical report of the structure, analysis of the load on the structure, calculation of internal forces, dimensioning of structural elements, calculation of joints and characteristic construction drawings.

Keywords:

truss structure, project, three-belt truss, purlins, sheathing rail, gable column, internal forces, technical report

**SVEUČILIŠTE U SPLITU
FAKULTET GRAĐEVINARSTVA, ARHITEKTURE I GEODEZIJE**

STUDIJ: **DIPLOMSKI SVEUČILIŠNI STUDIJ GRAĐEVINARSTVA**
KANDIDAT: Antonio Perić
BROJ INDEKSA: 756
KATEDRA: **Katedra za metalne i drvene konstrukcije**
PREDMET: Metalne konstrukcije

ZADATAK ZA DIPLOMSKI RAD

Tema: Izrada projektnog rješenja krovne konstrukcije sportske hale u Plzenu, Češka

Opis zadatka:

Prema zadanoj situaciji potrebno je izraditi glavni projekt rešetkaste čelične konstrukcije sportske dvorane u mjestu Plzen u Češkoj. Zadatak je zadan u suradnji s Faculty of Civil Engineering CTU Prague gdje je kandidat izradio diplomski rad, pod vodstvom Ing. Michal Jandera, Ph.D. Za predmetnu konstrukciju definirani su uvjeti gabarita konstrukcije, opterećenja prema Eurocode normi za lokaciju te zahtjevi investitora. Pored glavnog projekta konstrukcije, u sklopu zadataka, potrebno je obraditi i karakteristične spojeve.

U Splitu, 16.03.2020.

Voditelj Diplomskog rada:

doc.dr.sc. Vladimir Divić



Predsjednik Povjerenstva
za završne i diplomske ispite:
Doc. dr. sc. Ivo Andrić

Zahvala

Zahvaljujem obitelji, prijateljima i curi na podršci i pomoći te mentorima doc.dr.sc Vladimir Divić i Ing. Michal Jandera Ph.D. na strpljenju i stručnoj pomoći prilikom izrade ovog diplomskog rada.

Sadržaj

1. Technical report.....	1
1.1 Description of object	1
1.2 Construction calculation	2
1.3 Material.....	2
1.4 Assembly	3
1.5 Regulations	3
1.6 Corrosion protection	3
1.7 Fire safety	4
2. Loading on structure.....	5
2.1 Permanent actions.....	5
2.1.1 Dead load	5
2.1.2 Self-weight.....	5
2.2 Variable actions	5
2.2.1 Snow	5
2.2.2 Wind.....	9
2.2.3 Thermal actions.....	20
2.2.4 Sandwich panel selection	21
3. Construction calculation.....	22
3.1 Presentation of structure model	22
3.2 Display of individual load on the structure	23
3.2.1 self weight.....	24
3.2.2. Permanent load.....	24
3.2.3. Snow load.....	26
3.2.4. wind load (w_1).....	27
3.2.5. wind load (w_2).....	28
3.2.6. Thermal actions.....	28
3.3 Combination of actions.....	29
3.3.1 Ultimate limit state (ULS)	30
3.3.2 Serviceability limit states (SLS)	39
4. Calculation results	44
4.1. Deformations of construction	44
4.1.1. Vertical displacement (roof displacement)	44
4.1.2. Horizontal displacement (column displacement).....	45
4.1.3. Front sheating rail deflection	46
4.1.4. Gable column deflection	46
4.1.5. Sheating rail deflection	48
4.1.6. Purlins deflection	49
5. Construction calculation.....	53
5.1 Gable column (HEA500).....	53
5.2 Upper cord (CFCHS 168.3x6).....	63
5.3 lower cord 1 (CFCHS 193.7x5).....	73
5.4 Lower cord 2 (CFCHS 139.7x4)	81
5.5 Column grid (CFCHS 193.7x5).....	91
5.6 Horizontal cord (CFCHS 60.3x5).....	101
5.7 Horizontal grid 2 (CFCHS 76.1x5)	103
5.8 Vertikal cord (CFCHS 60.3x3).....	106
5.9 diagonal cord (CFCHS 88.9x6)	108
5.10 diagonal of upper cord (CFCHS 101.6x5).....	111
5.11 Inside bars of column (CFCHS 88.9x5).....	113

5.12 Bracing 1 (CFCHS 168.3x8)	116
5.13 Bracing 2 (CFCHS 152.4x5)	118
6. Joints calculation	121
6.1 Column grid – foundation joint	121
6.2 Upper cord connection.....	124
6.3 Lower cord connection	127
6.4 Diagonal cord connection	130
6.5 Welded gap „N“ joint	133
6.6 Welded gap „KT“ joint.....	136
6.7 Column grid – foundation joint	140
6.8 Welded „KK“ gap joint	143
6.9 Bracing – upper cord joint	150
6.10 Upper cord – concrete joint	155
6.11 Purlin – upper cord joint.....	157
7. Technical drawings	161
7.1. Floor plan of the construction (1:200).....	161
7.2. Elevations of the construction (1:100).....	161
7.3. Detail of sports hall frame (1:100)	161
7.4. Column bases connections (1:20).....	161
7.5. Details of connections (1:10).....	161
8. Literature	162

1. Technical report

1.1 Description of object

The subject of this Master thesis is the calculation of a steel truss structure within the project of a sports hall located in the city of Plzen in the Czech Republic. Closed hall is organized as one constructive-functional unit. Structural system is composed of cold formed steel profiles and a concrete core. Main roof structure is made in the form of a flat three-belt curved 3D truss placed on 10 columns properly distributed around the perimeter of the building. In the middle of the building there is a concrete core to which the roof steel structure is connected. The length of the concrete core is 39.5 m, the width is 20.0 m and the height is 7.3 m. Distance between the columns and the concrete core is 40.0 m. The axial distance between the columns is 9.5 m. Total width of the building is 103.0 m, while the length is 39.5 m. Total area of the roof surface is approximately 4069 m². The maximum height of the building is 17,182 m, and the height of the columns is 6.0 m.

The truss girders of the columns are 1.0 m high, the width is 1.5 m, and truss girders of the roof structure are 1.5 m high and 1.5 m wide, with the diagonals joining at the pressure cord in the middle of the belt. Diagonals are conceived as compression-tensile diagonals. The connection between the column and the truss structure was calculated and made as a hinge. Connection between the column and the truss will be made with end plates and bolts, where the top of the column is directly connected to the upper cord, while the connection between the truss column and the lower roof cord is made with a specially made profile with 6 arms. The columns are conceived as a three-belt 3D truss structure with a slope and a horizontal cord. The columns are articulated to the foundations, so that each belt of each column is connected to the foundation surface, through which they transfer the load to the foundation soil.

The foundations are reinforced concrete structures, made as isolated footing, rectangular floor plan, side dimensions 2.5 x 1.5 m. The height of the foundation is 0.8 m.

The problem of water runoff will not occur due to the 3D truss structure in the shape of an arch. It is planned to cover the roof and sides with sandwich panels, which were selected according to the calculated load on the structure for snow and uplift wind.

The load acting on the roof is transmitted through the purlins to the roof truss and through them to the columns of the structure. The roof panels are directly connected to the purlins with bolts.

Secondary columns (gable columns) and sheathing rails in the form of HEA and IPE cross-section girders have also been installed, which have the role of load transfer and enable easier installation of sandwich panels.

1.2 Construction calculation

The design calculation was performed using the software package Scia Engineer 19.1, and manual calculation according to EUROCODE 3. The calculation of internal forces was performed using the program Scia Engineer 19.1, dimensioning of structural elements was performed manual calculation according to EUROCODE 1993 part 1-1 while for the graphic part of the project used the program AutoCAD 2018. The calculation of internal forces was performed according to the linear theory of elasticity of the first order. The calculation includes all actions on the structure, namely self weight, constant loads, wind loads, snow loads as well as temperature actions.

With regard to the location of the Sports hall, a load analysis was made, which includes the effects of snow, wind and temperature. The Sports hall is located in the area of Plzen in the Czech Republic, which belongs to the I. snow load zone, which gives the characteristic value of the snow load on the ground. The altitude at which the structure is located was also taken into account. Zone II, land category III was taken into account for the wind load, and the height of the building and its protection were taken into account. Since wind is the dominant load for this type of building, great attention was paid to it and especially the compressive and uplift pressure action of the wind was observed, as well as friction in the roof surface.

The results presented in the graphical part of this project include internal forces and displacements of certain parts of the structure. Internal forces are given in units of kN for shear and axial forces, kNm for moments, and mm for structural displacements.

All construction elements are dimensioned by manual calculation according to EUROCODE 1993 part 1-1. The construction is shown by a 3D model in Scia Engineer 19.1 with a load acting vertically and in the plane of the roof surface. The belt elements of the truss girders are modeled as beam elements, while the infill of the roof structure and columns is defined as a rod element that transmits only the axial force.

By defining the model in this way, we can consider that an articulated connection is achieved at the joint of the infill and the truss girder cord. Joints of the columns with the foundations were treated as articulated. All relevant load combinations are taken into account, and each element is dimensioned according to its internal forces. Foundations and all joints are calculated manually according to EUROCODE 1993 part 1-8.

1.3 Material

The material for the main load-bearing roof structure, as well as the columns, is steel S275.

The structural elements will be interconnected by bolt joints. The bolts used to make this construction are M 16 and M 20, all quality 8.8.

Joints and extensions of structural elements include additional plates and stiffeners, also of the same S275 steel quality. For the lining of the building, we use tin sandwich panels whose load capacity is given in the table. The foundations are reinforced concrete, concrete class C 25/30.

1.4 Assembly

The construction is prefabricated. All prefabricated construction elements arrive at the construction site and are connected to each other with bolts. The roof structure itself is made of 10 types of 3D segments, with 5 segments being the same as the other 5 due to the symmetry of the structure. The first segment (segment 1) is 6.5 m high, 1.5 m wide and approximately 12 m long, and the same segment is located on the second column. The edge segment (segment 2) is 5.2 m high, 1.5 m wide and 6.5 m long, and is also equal to the 10th segment. Segments 1 and 6 are connected to segments 3 and 8, which are of equal dimensions, approx. 3.3 m high, 1.5 m wide and approx. 11 m long. Segments 4 and 9 are bolted to segments 2 and 7, which are approx. 4 m high, 1.5 m wide and approx. 9.7 m long. Both central segments are at a height of 17 meters above ground level. By supporting the segments, the load-bearing structure will be mounted. These 10 segments together form the main framework of the 3D construction. The zero phase of the assembly, after all the previously necessary works have been performed, is the assembly of the columns. When the column (segment 11) is placed on the anchors placed in the foundations, the column is held by the crane until verticality is achieved by means of double bolts. After checking the verticality, the space under the joint plate and the foundation is filled with expanding mortar. After that, the edge (segments 1 and 2, 6 and 7) and 3 (8) and 4 (9) and the central segments (5 and 10) are connected to the columns and placed in place with the help of a crane. The next step is to install the next frame and connect the frame to the transverse segments with sheathing rails and purlins and secondary gable columns and sheathing rails from the front. In this way, each subsequent frame is set to the end. Assembly begins over the columns, followed by assembly of the other segments of the structure. This method of installation was chosen because we have a low-capacity crane at our disposal.

1.5 Regulations

The calculation and dimensioning of all elements of the steel structure were performed in accordance with EUROCODE 3, and the analysis of the effect on the structure was made in accordance with EUROCODE 1. The calculation and dimensioning of concrete structural elements was performed in accordance with EUROCODE 2. The calculation of welded and bolted joints according to EN 1993, part 1-8.

1.6 Corrosion protection

In the case of steel, corrosion means the oxidation of iron under the action of moisture and various impurities. Rust accelerators are the polluted atmosphere, the industrial area polluted with sulfur, salt, etc.

Protection of steel structures from rust is performed by:

- coatings
- zinc protection
- metallization
- using special steels
- cathodic protection

Coating protection is done to prevent oxygen and moisture from coming into contact with the steel. Coating is usually done by painting in two layers: a base coat and a protective coating.

The base coat directly protects the steel, and it needs to be made of substances that are not harmful to human health. The protective layer serves to protect the base coat.

Premature deterioration of the structure usually occurs due to poor details in the structure (inaccessible places for painting, places where water is retained, sharp edges where the required thickness of the coating cannot be applied, etc.) which should be avoided.

The painting protection system consists of:

- Surface preparation - the durability of the coating depends on the adhesion of the paint to the metal surface, which depends on the cleanliness of the surface before painting. Cleaning is done with brushes, sandblasting, burner or chemical agents.

- Application of paint - painting is done with a brush, roller or spray. Attention should be paid to the restrictions for individual colors. The number of layers of coating usually consists of two and specifically of four or more layers. A new coating can only be applied when the previous one is completely dry. Special attention should be paid to the thickness of the coating. In general, a thicker coating increases the durability of the protection. The total thickness of dry coatings should range between 0.1-0.4 mm.

Well-executed coatings last:

- up to 30 years indoors
- up to 20 years in rain-protected structures
- up to 10 years in nature
- 2-3 years in a polluted environment

1.7 Fire safety

The implementation of all regulations on fire protection will be ensured. Access and intervention of the fire truck will be provided from the south side of the object. Required fire resistance of steel structure elements F30. We ensure fire resistance with special expanding coatings.

2. Loading on structure

2.1 Permanent actions

2.1.1 Dead load

Roof surface

- panels 0,11 kN/m²

Σ = 0,11 kN/m²

-instalation 0,10 kN/m²

- workers 0,75 kN/m²

Σ = 0,85 kN/m²

2.1.2 Self-weight

The self-weight of the steel structure elements is added automatically in the software Scia Engineer used for the global analysis.

2.2 Variable actions

2.2.1 Snow

Analysis according to EN1991-1-3:2003

Snow loads on roofs (for the persistent situations) is determined with:

$$s = \mu_i \cdot C_e \cdot C_t \cdot s_k [\text{kN/m}^2]$$

Where:

μ_i – koeficijent oblika opterećenja snijegom

s_k – Characteristic value of snow on the ground at the relevant site [kN/m²]

C_e – Exposure coefficient

$C_e = 1,0$

C_t – thermal coefficient

$C_t = 1,0$

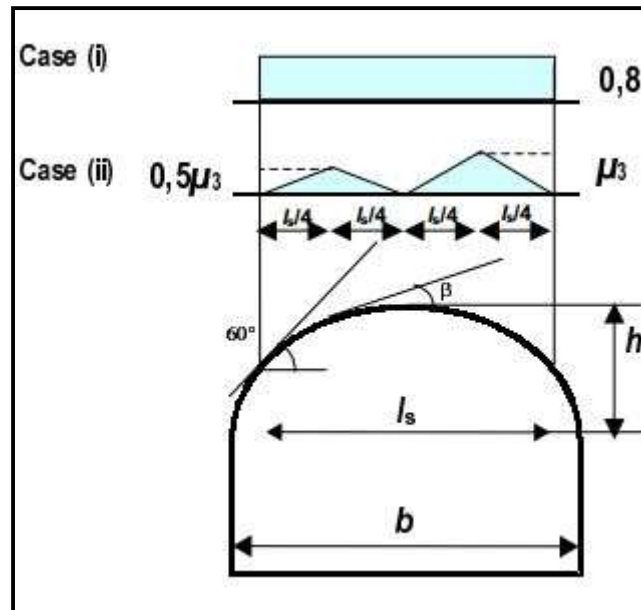

Figure 2.1. Snow load shape coefficients for cylindrical roof

The snow load shape coefficients that should be used for cylindrical roofs, in absence of snow fences, are given in the following expressions:

Za $\beta \leq 60^\circ$:	Za $\beta > 60^\circ$:
$\mu_1 = 0.8$	$\mu_1 = 0.0$
$\mu_2 = 0.2 + 10 \cdot (h/l)$	$\mu_2 = 0.0$
$\mu_3 = 0.5\mu_2$	$\mu_3 = 0.0$

An upper value of μ_3 should be specified.

The upper value of μ_3 may be specified in the National Annex. The recommended upper value for μ_3 is 2,0

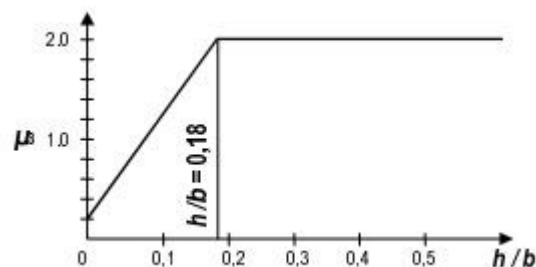

Figure 2.2. Recommended snow load shape coefficient for cylindrical roofs of differing rise to span ratios (for $\beta \leq 60^\circ$)

$$h/l = 0,26 \Rightarrow \mu_1 = 0,8, \mu_2 = 2,8, \mu_3 = 1,4$$

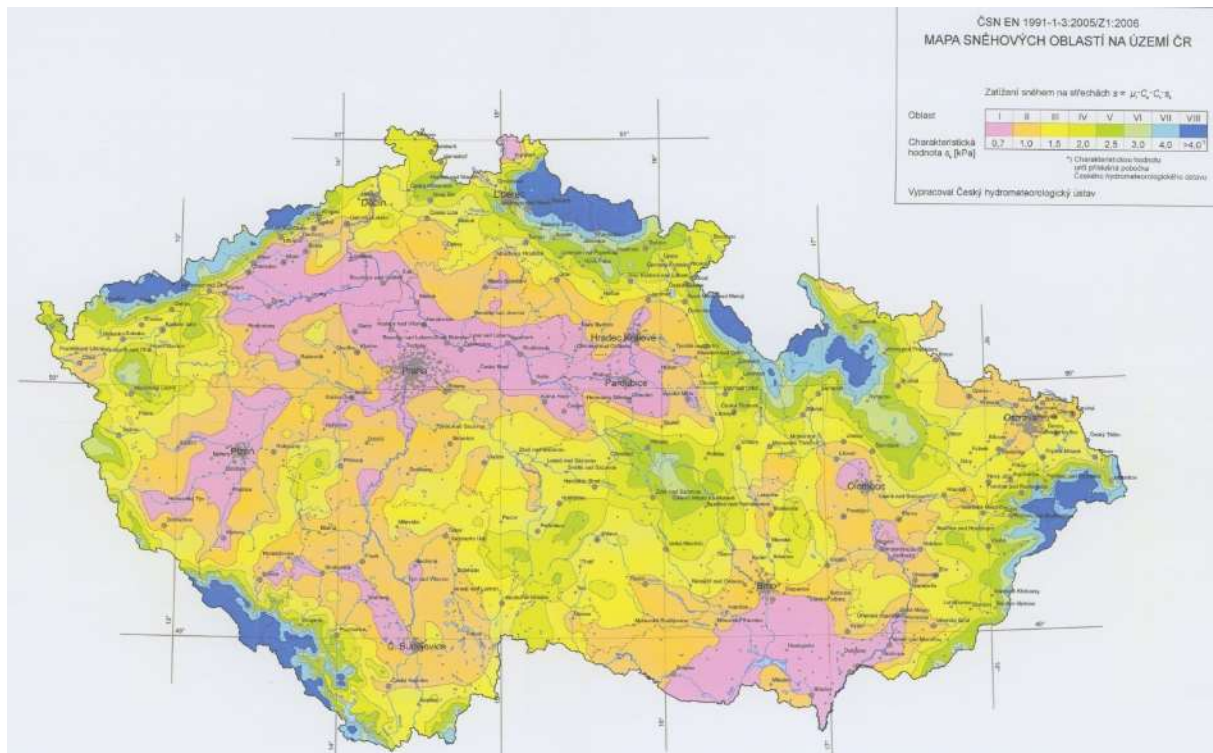

Figure 2.3. Snow map for Czech Republic

Location of object: Plzen

$$s_k = 0,7 \text{ [kN/m}^2\text{]}$$

- C_e - Exposure coefficient $\Rightarrow C_e = 1,0$

- C_t - thermal coefficient $\Rightarrow C_t = 1,0$

$$s_1 = \mu_i \cdot C_e \cdot C_t \cdot s_k \quad \text{[kN/m}^2\text{]}$$

$$s_1 = 0,8 \cdot 1,0 \cdot 1,0 \cdot 0,7$$

$$s_1 = 0,56 \text{ kN/m}^2$$

$$s_2 = \mu_i \cdot C_e \cdot C_t \cdot s_k \quad \text{[kN/m}^2\text{]}$$

$$s_2 = 2,8 \cdot 1,0 \cdot 1,0 \cdot 0,7$$

$$s_2 = 1,96 \text{ kN/m}^2$$

$$s_3 = \mu_i \cdot C_e \cdot C_t \cdot s_k \quad \text{[kN/m}^2\text{]}$$

$$s_3 = 1,4 \cdot 1,0 \cdot 1,0 \cdot 0,7$$

$$s_3 = 0,98 \text{ kN/m}^2$$

Angle of pitch of roof α	$0^\circ \leq \alpha \leq 30^\circ$	$30^\circ < \alpha < 60^\circ$
μ_1	0,8	$0.8(60 - \alpha)/30$
μ_2	$0,8 + 0,8 \alpha/30$	1,6

Table 2.1: Snow load shape coefficients

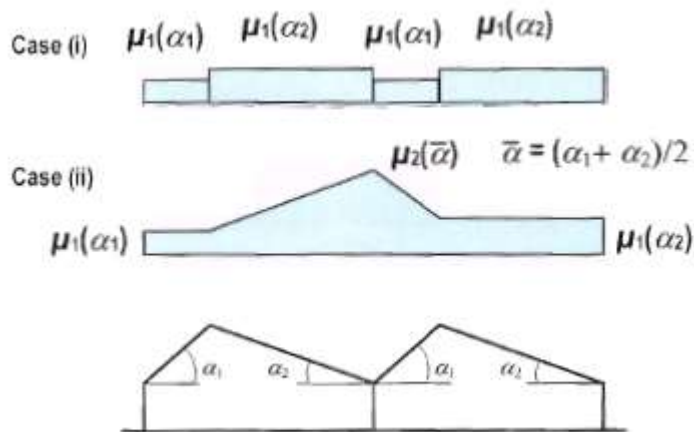

Figure 2.4. Snow load shape coefficients for multi-span roofs

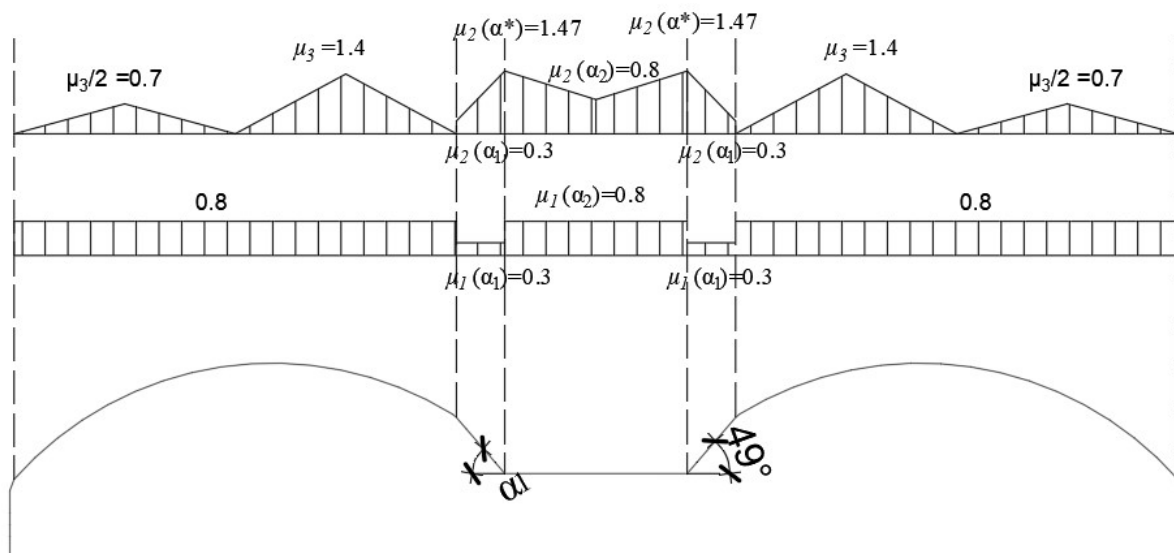

Figure 2.5. Snow load shape coefficients for sports hall

From **Table 2.1:**

$$\alpha_1 = 49^\circ$$

$$\alpha_2 = 0^\circ$$

$$\alpha' = (\alpha_1 + \alpha_2) / 2 = 25^\circ$$

$$\mu_1(\alpha_1) = 0,8$$

$$\mu_1(\alpha_2) = 0,3$$

$$\mu_2(\alpha') = 0,8 + 0,8 * (\alpha' / 30) = 1,47$$

$$s_1 = \mu_i \cdot C_e \cdot C_t \cdot s_k \quad [\text{kN/m}^2]$$

$$s_1 = 0,8 \cdot 1,0 \cdot 1,0 \cdot 0,7$$

$$s_1 = 0,56 \text{ kN/m}^2$$

$$s_2 = \mu_i \cdot C_e \cdot C_t \cdot s_k \quad [\text{kN/m}^2]$$

$$s_2 = 0,3 \cdot 1,0 \cdot 1,0 \cdot 0,7$$

$$s_2 = 0,21 \text{ kN/m}^2$$

$$s_3 = \mu_i \cdot C_e \cdot C_t \cdot s_k \quad [\text{kN/m}^2]$$

$$s_3 = 1,47 \cdot 1,0 \cdot 1,0 \cdot 0,7$$

$$s_3 = 1,03 \text{ kN/m}^2$$

2.2.2 Wind

Wind pressure (vertical) on surfaces:

The wind pressure acting on the external surfaces: $w_e = q_p(z_e) \cdot c_{pe} [\text{kN/m}^2]$

The wind pressure acting on the internal surfaces: $w_i = q_p(z_i) \cdot c_{pi} [\text{kN/m}^2]$

Where:

$q_p(z_{(e)i})$ – is the peak velocity pressure

$z_{(e)i}$ – is the reference height for the external (internal) pressure

c_{pe} – is the pressure coefficient for the external pressure

c_{pi} – is the pressure coefficient for the internal pressure

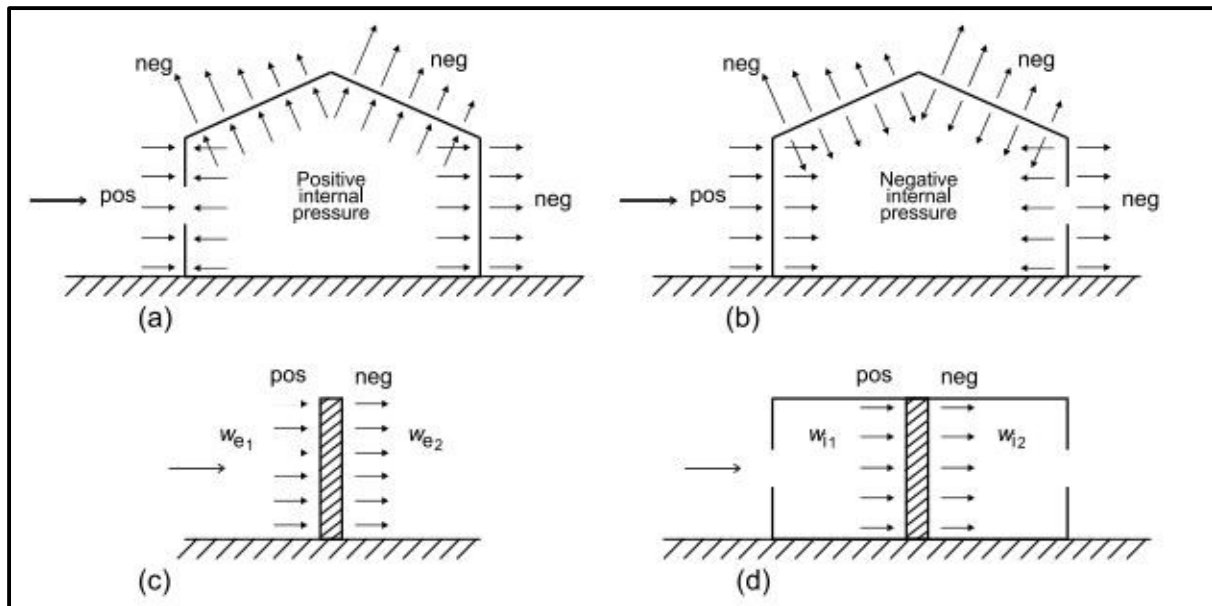

Figure 2.6. - Pressure on surfaces

q is the basic velocity pressure given in Expression:

$$q_b = \frac{1}{2} \cdot \rho \cdot v_b^2 \text{ [kN/m}^2\text{]}$$

Where:

ρ – is air density, which depends on the altitude, temperature and barometric pressure to be expected in the region during wind storms (adopted value is $\rho = 1,25 \text{ kg/m}^3$)

v_b – is the basic wind velocity

The basic wind velocity shall be calculated from Expression:

$$v_b = c_{dir} \cdot c_{season} \cdot v_{b,0} \text{ [m/s]}$$

where:

$v_{b,0}$ – is the fundamental value of the basic wind velocity

c_{dir} – is the directional factor

$c_{dir} = 1,0$

c_{season} – is the season factor

$c_{season} = 1,0$

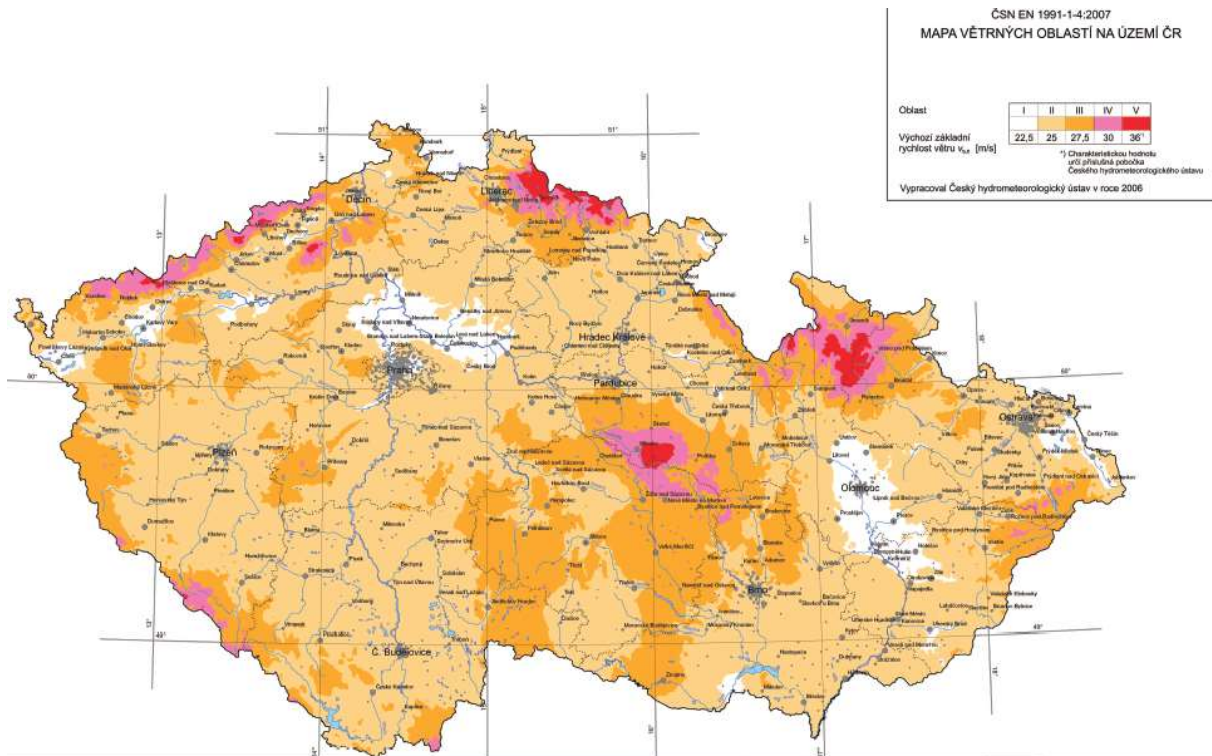

Figure 2.7. value map of the basic wind velocity in Czech Republic

Basic wind velocity from the map for Plzen: $v_{b,0} = 25,0$ [m/s]

$$v_b = 1,0 \cdot 1,0 \cdot 25,0 = 25,0 \text{ [m/s]}$$

The mean wind velocity $v_m(z)$ at a height z above the terrain depends on the terrain roughness and orography and on the basic wind velocity, V_b , and is determined with Expression:

$$v_m(z) = c_r(z) \cdot c_0(z) \cdot v_b(z) \text{ [m/s]}$$

Where:

$c_r(z)$ – is the roughness factor

$c_0(z)$ – is the orography factor

It's usually taken as 1,0 unless otherwise specified $c_0(z) = 1,0$.

The roughness factor, $c_r(z)$, accounts for the variability of the mean wind velocity at the site of the structure due to:

- the height above ground level
- the ground roughness of the terrain upwind of the structure in the wind direction considered

The recommended procedure for the determination of the roughness factor $c_r(z)$ at height z is given by Expression:

$$c_r(z) = k_r \cdot \ln(z/z_0) \text{ za } z_{\min} \leq z \leq z_{\max}$$

$$c_r(z) = c_r(z_{\min}) \text{ za } z \leq z_{\min}$$

Where:

z_0 – is the roughness length

k_r – terrain factor depending on the roughness length z_0 calculated using

z_{\min} – is the minimum height

z_{\max} – is the maximum height

z_{\max} is to be taken as 200 [m]

Terrain factor depending on the roughness length z_0 calculated using:

$$k_r = 0,19 \cdot \left(\frac{z_0}{z_{0,II}} \right)^{0,07}$$

Where:

$z_{0,II} = 0,05$ m (terrain category II)

z_0, z_{\min} depend on the terrain category. Recommended values are given in Table 2. depending on five representative terrain categories.

Terrain category		z_0 m	z_{\min} m
0	Sea or coastal area exposed to the open sea	0,003	1
I	Lakes or flat and horizontal area with negligible vegetation and without obstacles	0,01	1
II	Area with low vegetation such as grass and isolated obstacles (trees, buildings) with separations of at least 20 obstacle heights	0,05	2
III	Area with regular cover of vegetation or buildings or with isolated obstacles with separations of maximum 20 obstacle heights (such as villages, suburban terrain, permanent forest)	0,3	5
IV	Area in which at least 15 % of the surface is covered with buildings and their average height exceeds 15 m	1,0	10
NOTE: The terrain categories are illustrated in A.1.			

Table 2.2. Values z_0 i z_{\min} for different terrain categories

Terrain category 0

Sea, coastal area exposed to the open sea

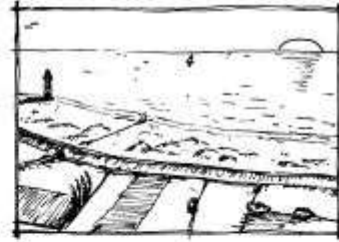

Terrain category I

Lakes or area with negligible vegetation and without obstacles



Terrain category II

Area with low vegetation such as grass and isolated obstacles (trees, buildings) with separations of at least 20 obstacle heights



Terrain category III

Area with regular cover of vegetation or buildings or with isolated obstacles with separations of maximum 20 obstacle heights (such as villages, suburban terrain, permanent forest)



Terrain category IV

Area in which at least 15 % of the surface is covered with buildings and their average height exceeds 15 m



Figure 2.8. Illustrations of the upper roughness of each terrain category

Terrain category III, Plzen

Taken from the table: $z_{0,III} = 0,3$ [m]

$z_{min} = 5,0$ [m]

$$k_r = 0,19 \cdot \left(\frac{0,3}{0,05}\right)^{0,07} = 0,215$$

$z = 17,2$ [m] $\rightarrow 5,0 \leq 17,2 \leq 200,0$

$c_r(z) = k_r \cdot \ln(z/z_0) = 0,215 \cdot \ln(17,2/0,3) = 0,871$

$v_m(z) = c_r(z) \cdot c_0(z) \cdot v_b(z) = 0,871 \cdot 1,0 \cdot 25,0 = 21,78$ [m/s]

The turbulence intensity $I_v(z)$ at height z is defined as:

$$I_v(z) = \frac{k_I}{c_0(z) \cdot \ln(z/z_0)}$$

Where:

k_I – is the turbulence factor.

The value of k_I may be given in the National Annex. The recommended value for k_I is 1,0.

The peak velocity pressure $q_p(z)$ at height z , which includes mean and short-term velocity fluctuations, should be determined by:

$$q_p(z) = c_e(z) \cdot q_b = [1 + 7 \cdot I_v(z)] \cdot \frac{1}{2} \cdot \rho \cdot v_m^2(z)$$

Where:

$c_e(z)$ – is the exposure factor

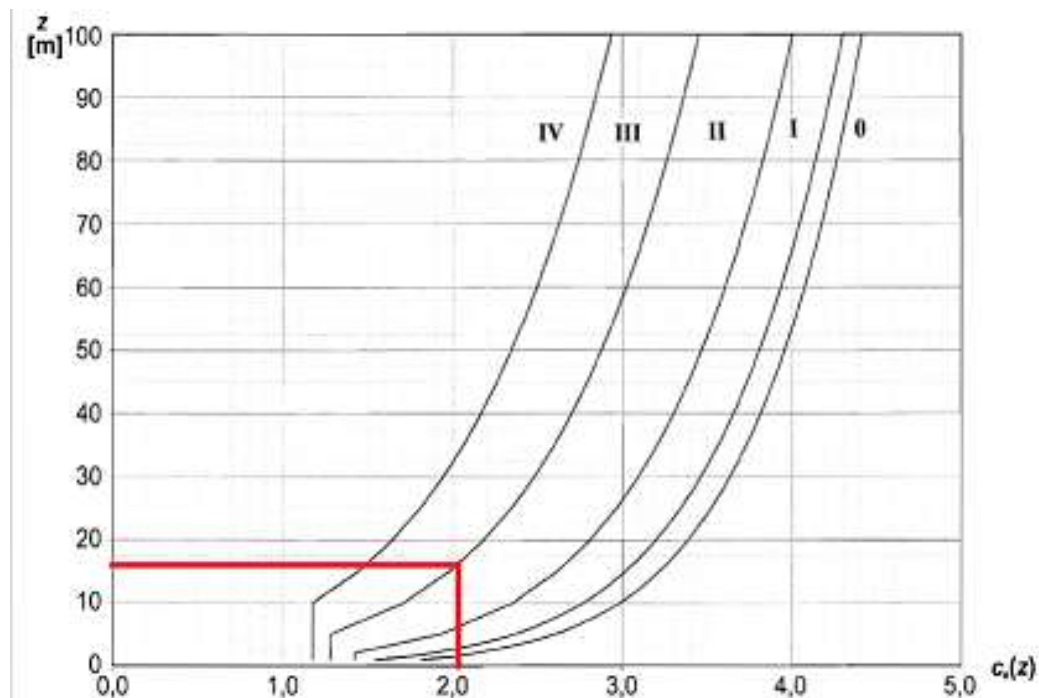

Figure 2.9. Illustrations of the exposure factor $c_e(z)$ for $c_0 = 1,0$, $k_I = 1,0$ $c_e(z)$ za $c_0 = 1,0$ i $k_I = 1,0$

Taken from the figure: $c_e(z) = 2,10$

$$I_v(z) = \frac{k_I}{c_0(z) \cdot \ln(z/z_0)} = \frac{1,0}{1,0 \cdot \ln(17,2/0,3)} = 0,25$$

$$q_p(z) = [1 + 7 \cdot I_v(z)] \cdot \frac{1}{2} \cdot \rho \cdot v_m^2(z) = [1 + 7 \cdot 0,25] \cdot \frac{1}{2} \cdot 1,25 \cdot 21,78^2$$

$$q_p(z) = 815,32 \text{ [N/m}^2\text{]}$$

$$q_p(z) = c_e(z) \cdot q_b$$

$$q_b = \frac{1}{2} \cdot \rho \cdot v_b^2 = \frac{1}{2} \cdot 1,25 \cdot 25,0^2 = 390,63 \text{ [N/m}^2\text{]}$$

$$q_p(z) = c_e(z) \cdot q_b = 2,10 \cdot 390,63 = 820,32 \text{ [N/m}^2\text{]}$$

as authoritatively taken: $q_p(z) = 820,32 \text{ [N/m}^2\text{]} = 0,821 \text{ [kN/m}^2\text{]}$

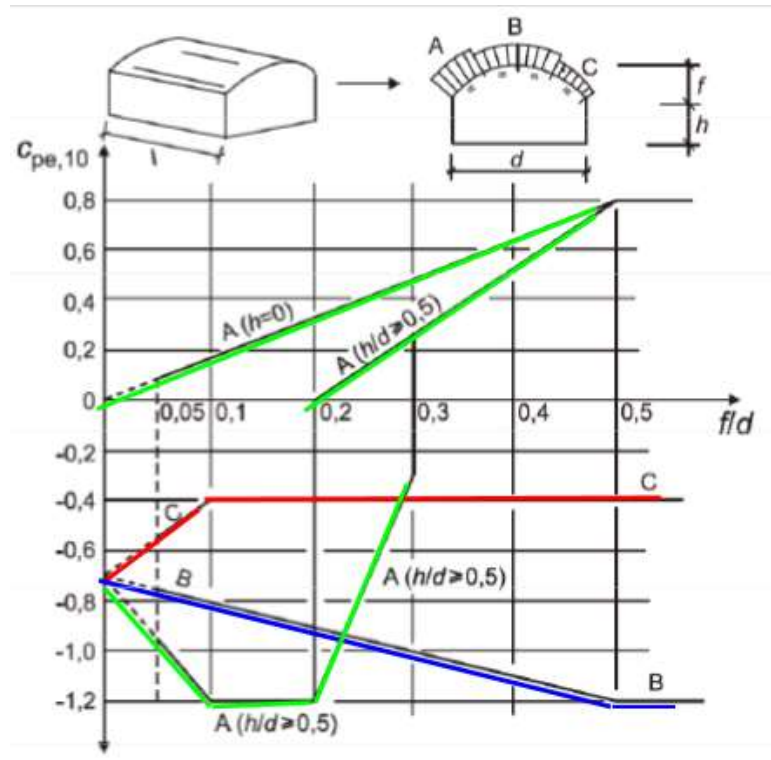

Figure 2.10. Recommended values of external pressure coefficients $c_{pe,10}$ for vaulted roofs with rectangular base

The net pressure on a wall, roof or element is the difference between the pressures on the opposite surfaces taking due account of their signs. Pressure, directed towards the surface is taken as positive, and suction, directed away from the surface as negative.

$$w_e = q_p(z_e) \cdot c_{pe} \text{ [kN/m}^2\text{]}$$

$$q_p(z_e) = 0,821 \text{ [kN/m}^2\text{]}$$

w₁ (c_{pi}=+0,2)

$$f/d = 11,2\text{m}/40,0\text{m} = 0,28$$

$$h/d = 6,0\text{m}/40,0\text{m} = 0,15$$

Area	Area A	Area B	Area C
c_{pe}	0,3	-1,0	-0,4
$w_e \text{ [kN/m}^2\text{]}$	0,25	-0,82	-0,33
Friction (kN/m ²)	0,005	-0,02	-0,007

Wind from inside : $w_e = q_p(z_e) \cdot c_{pi} \text{ [kN/m}^2\text{]}$

From inside (kN/m ²) $c_{pi}=+0,2$	0,16
---	------

Wind w_1 :

Area	Area A	Area B	Area C
W_{e1} [kN/m ²]	0,41	-0,66	-0,17

coefficient of friction

coefficient of friction c_{fr} for walls and roofs:

Surface	Friction coefficient c_{fr}
Smooth (i.e. steel, smooth concrete)	0,01
Rough (i.e. rough concrete, tar-boards)	0,02
very rough (i.e. ripples, ribs, folds)	0,04

Table 2.3. Frictional coefficients c_{fr} for walls, parapets and roof surfaces

Construction is covered with a ribbed, wrinkled coating so coefficient of friction is
 $C_{fr} = 0,02$

Friction because of wind is determined with:

$$w_e = 0,02 \cdot q_{ref} \cdot c_e \cdot c_{p,net}$$

WALL:

$$w_e = q_p(z_e) \cdot c_{pe} \text{ [kN/m}^2\text{]}$$

$$q_p(z_e) = 0,821 \text{ [kN/m}^2\text{]}$$

Područje	A		B		C		D		E	
	$c_{pe,10}$	$c_{pe,1}$	$c_{pe,10}$	$c_{pe,1}$	$c_{pe,10}$	$c_{pe,1}$	$c_{pe,10}$	$c_{pe,1}$	$c_{pe,10}$	$c_{pe,1}$
5	-1,2	-1,4	-0,8	-1,1	-0,5		+0,8	+1,0		-0,7
1	-1,2	-1,4	-0,8	-1,1	-0,5		+0,8	+1,0		-0,5
≤0,25	-1,2	-1,4	-0,8	-1,1	-0,5		+0,7	+1,0		-0,3

Table 2.4. - Recommended values of external pressure coefficients for vertical walls of rectangular plan buildings

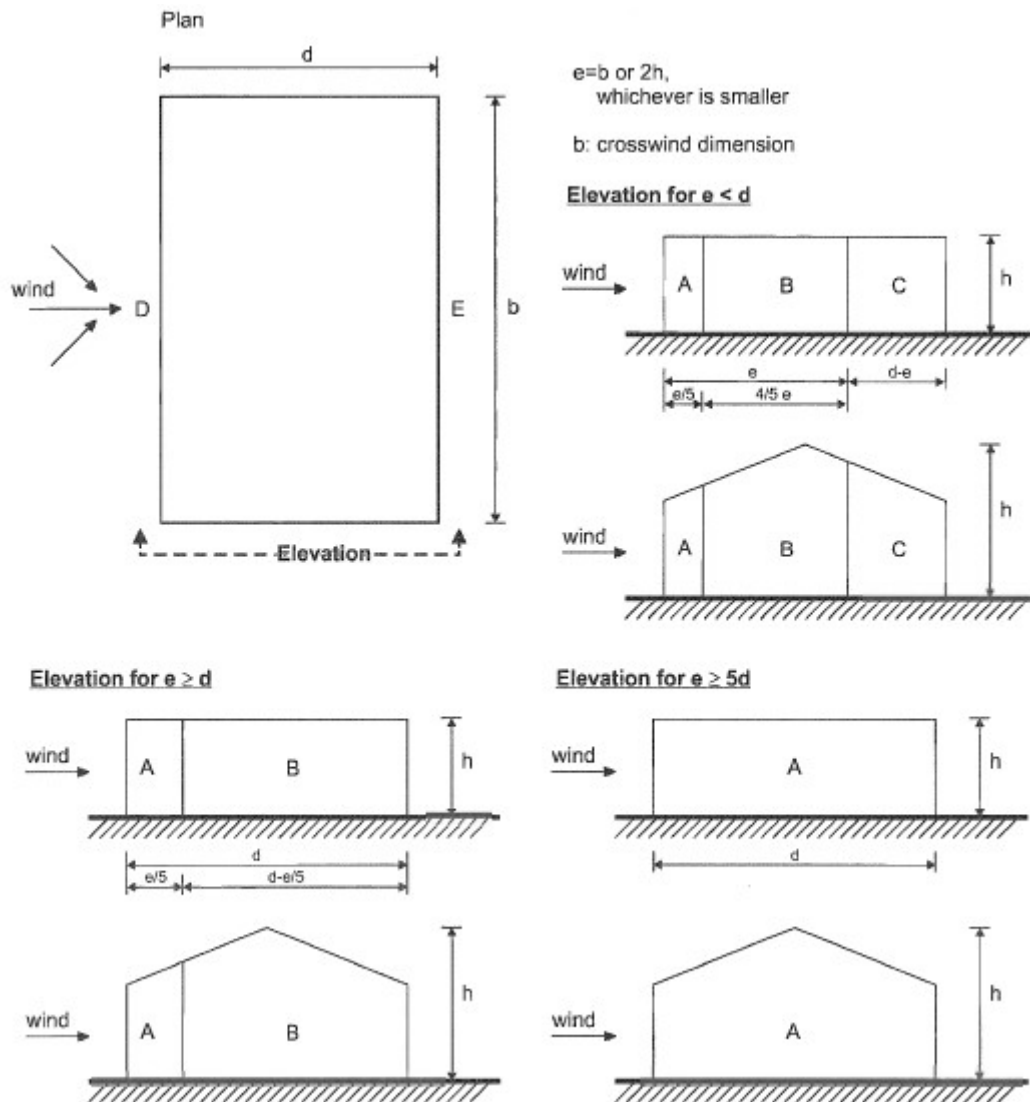

Figure 2.11. - Key for vertical walls

Area	Area A	Area B	Area C	Area D	Area E
c_{pe}	-1,20	-0,80	-0,5	+0,7	-0,3
w_e [kN/m ²]	-1,00	-0,66	-0,41	+0,60	-0,25
Friction(kN/m ²)	-0,01	-0,01	-0,01	+0,01	-0,003

Wind from inside : $w_e = q_p(z_e) \cdot c_{pi}$ [kN/m²]

From inside (kN/m ²) $c_{pi}=+0,2$	0,16
---	------

WALL W₁:

Area	Area A	Area B	Area C	Area D	Area E
W_e [kN/m ²]	-0,84	-0,50	-0,25	+0,76	-0,09

w₂ (c_{pi}=-0,3):

Area	Area A	Area B	Area C
c _{pe}	0,3	-1,0	-0,4
w _e [kN/m ²]	0,25	-0,82	-0,33
trenje(kN/m ²)	0,003	-0,01	-0,004

Wind from inside : w_e = q_p(z_e) · c_{pi}[kN/m²]

From inside (kN/m ²) c _{pi} =-0,3	-0,25
--	-------

Wind w₂:

Area	Area A	Area B	Area C
w _{e2} [kN/m ²]	0,0	-1,07	-0,58

coefficient of friction

coefficient of friction c_{fr} for walls and roofs:

Surface	Friction coefficient c _{fr}
Smooth (i.e. steel, smooth concrete)	0,01
Rough (i.e. rough concrete, tar-boards)	0,02
very rough (i.e. ripples, ribs, folds)	0,04

Table 2.5. Frictional coefficients c_{fr} for walls, parapets and roof surfaces

Construction is covered with a ribbed, wrinkled coating so coefficient of friction is
C_{fr} = 0,02

Friction because of wind is determined with:

$$w_e = 0,02 \cdot q_{ref} \cdot c_e \cdot c_{p,net}$$

WALL:

$$w_e = q_p(z_e) \cdot c_{pe} [\text{kN/m}^2]$$

$$q_p(z_e) = 0,821 [\text{kN/m}^2]$$

Područje	A		B		C		D		E	
h/d	$c_{pe,10}$	$c_{pe,1}$	$c_{pe,10}$	$c_{pe,1}$	$c_{pe,10}$	$c_{pe,1}$	$c_{pe,10}$	$c_{pe,1}$	$c_{pe,10}$	$c_{pe,1}$
5	-1,2	-1,4	-0,8	-1,1	-0,5		+0,8	+1,0	-0,7	
1	-1,2	-1,4	-0,8	-1,1	-0,5		+0,8	+1,0	-0,5	
$\leq 0,25$	-1,2	-1,4	-0,8	-1,1	-0,5		+0,7	+1,0	-0,3	

Table 2.6. Recommended values of external pressure coefficients for vertical walls of rectangular plan buildings

Area	Area A	Area B	Area C	Area D	Area E
c_{pe}	-1,20	-0,80	-0,5	+0,70	-0,30
w_e [kN/m ²]	-1,00	-0,66	-0,41	+0,60	-0,25
trenje(kN/m ²)	-0,01	-0,01	-0,01	+0,01	-0,003

Wind from inside : $w_e = q_p(z_e) \cdot c_{pi} [\text{kN/m}^2]$

From inside (kN/m ²) $c_{pi} = -0,3$	-0,25
--	-------

Wall W₂:

Area	Area A	Area B	Area C	Area D	Area E
W_e [kN/m ²]	-1,25	-0,91	-0,66	+0,35	-0,55

2.2.3 Thermal actions

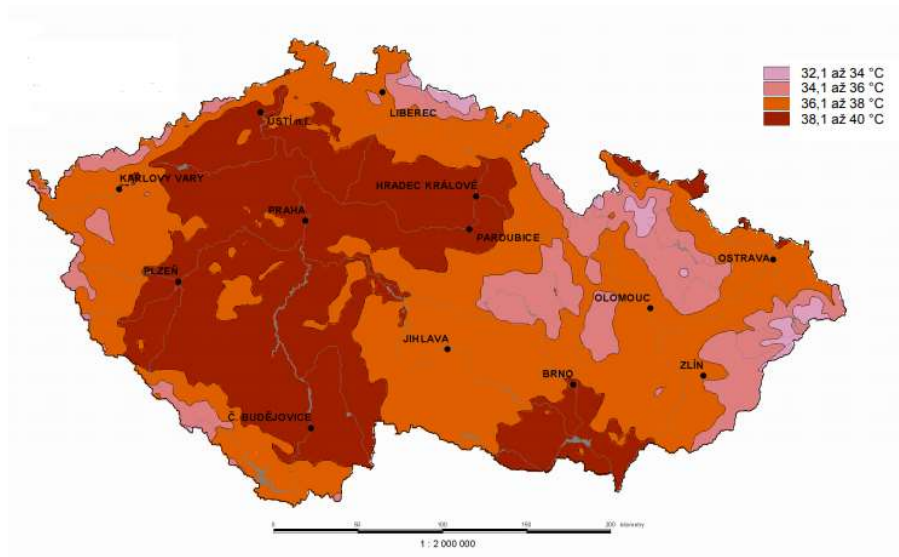

Figure 2.12. Temperature map of T_{max} for Czech Republic

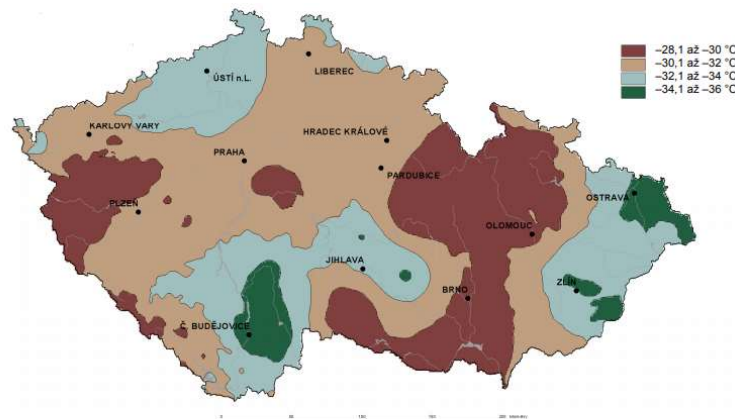

Figure 2.13. Temperature map of T_{min} for Czech Republic

Highest temperature in the shade for Plzeň: $T_{max} = 40\text{ }^{\circ}\text{C}$

Lowest temperature in the shade for Plzeň: $T_{min} = -5\text{ }^{\circ}\text{C}$

The lowest temperature is taken $-5\text{ }^{\circ}\text{C}$ because in real life it's almost impossible to have $-32\text{ }^{\circ}\text{C}$ as it should be taken from the temperature map.

A uniform temperature change in all sections is assumed.

Assumed temperature during installation of construction is $T = 10\text{ }^{\circ}\text{C}$

Maximum positive temperature change: $T_{max} = 40\text{ }^{\circ}\text{C} - 10\text{ }^{\circ}\text{C} = 30\text{ }^{\circ}\text{C}$

Maximum negative temperature change: $T_{min} = -5\text{ }^{\circ}\text{C} - 10\text{ }^{\circ}\text{C} = -15\text{ }^{\circ}\text{C}$

2.2.4 Sandwich panel selection

$l = 2,65\text{m} \Rightarrow$ span between purlins

sandwich panels taken from ruukki tables



PIR sandwich panels • Load tables

• **Maximum allowable snow load [kN/m²] for the length of span made of Ruukki SP2C 100/60PIR panels** Table 12

External facing thickness: 0.50 mm
Internal facing thickness: 0.40 mm
External temperature: +55°C; +65°C; +80°C/-20°C (summer/winter)
Internal temperature: +20°C/+20°C (summer/winter)
Minimum end support width: 40 mm
Minimum intermediate support width: 60 mm
Minimum number of fasteners at the end support: 2 or 3
Minimum number of fasteners at the intermediate support: 3

ULS - Ultimate Limit State
ULS 2/0 - Ultimate Limit State; 2 fasteners at an end support
ULS 1/0 - Ultimate Limit State; 1 fastener at an end support
ULS 2/3 - Ultimate Limit State; 2 fasteners at an end support / 3 fasteners at an intermediate support
ULS 1/3 - Ultimate Limit State; 1 fastener at an end support / 3 fasteners at an intermediate support
SLS - Serviceability Limit State

Static scheme	Colour group	Criterion	Span length [m]												
			1.00	1.50	2.00	2.50	3.00	3.50	4.00	4.50	5.00	5.50	6.00	6.50	
Multi-span system	I	ULS 2/3	5.08	3.41	2.56	2.04	1.70	1.32	1.05	0.86	0.71	0.60	0.52	0.45	
		ULS 1/3	5.08	3.40	2.56	2.04	1.70	1.32	1.05	0.86	0.71	0.61	0.52	0.44	
		SLS	L/200	22.89	8.02	4.01	2.41	1.61	1.14	0.85	0.65	0.50	0.39	0.31	0.24
			L/250	18.30	6.39	3.19	1.91	1.26	0.89	0.66	0.50	0.38	0.29	0.23	0.18
		II	ULS 2/3	5.08	3.41	2.56	2.04	1.70	1.32	1.05	0.86	0.71	0.60	0.52	0.45
			ULS 1/3	5.08	3.40	2.56	2.04	1.70	1.32	1.05	0.86	0.71	0.61	0.52	0.44
	SLS		L/200	22.89	8.02	4.01	2.41	1.61	1.14	0.85	0.65	0.50	0.39	0.31	0.24
			L/250	18.30	6.39	3.19	1.91	1.26	0.89	0.66	0.50	0.38	0.29	0.23	0.18
	III		ULS 2/3	5.08	3.41	2.56	2.04	1.70	1.32	1.05	0.86	0.71	0.60	0.52	0.45
			ULS 1/3	5.08	3.40	2.56	2.04	1.70	1.32	1.05	0.86	0.72	0.60	0.52	0.44
		SLS	L/200	22.89	8.02	4.01	2.41	1.61	1.14	0.85	0.65	0.50	0.39	0.31	0.24
			L/250	18.30	6.39	3.19	1.91	1.26	0.89	0.66	0.50	0.38	0.29	0.23	0.18

Table 2.14. Maximum allowable snow load [kN/m²] for the length of span made of Ruukki SP2C 100/60PIR panel

• **Maximum allowable wind suction [kN/m²] for the length of span made of Ruukki SP2C 100/60PIR panels** Table 13

External facing thickness: 0.50 mm
Internal facing thickness: 0.40 mm
External temperature: +55°C; +65°C; +80°C/-20°C (summer/winter)
Internal temperature: +20°C/+20°C (summer/winter)
Minimum end support width: 40 mm
Minimum intermediate support width: 60 mm
Minimum number of fasteners at the end support: 2 or 3
Minimum number of fasteners at the intermediate support: 3

ULS - Ultimate Limit State
ULS 2/0 - Ultimate Limit State; 2 fasteners at an end support
ULS 1/0 - Ultimate Limit State; 1 fastener at an end support
ULS 2/3 - Ultimate Limit State; 2 fasteners at an end support / 3 fasteners at an intermediate support
ULS 1/3 - Ultimate Limit State; 1 fastener at an end support / 3 fasteners at an intermediate support
SLS - Serviceability Limit State

Static scheme	Colour group	Criterion	Span length [m]												
			1.00	1.50	2.00	2.50	3.00	3.50	4.00	4.50	5.00	5.50	6.00	6.50	
Multi-span system	I	ULS 2/3	5.26	3.54	2.69	2.10	1.58	1.26	1.04	0.89	0.77	0.68	0.61	0.55	
		ULS 1/3	2.78	1.88	1.51	1.30	1.13	1.02	0.92	0.85	0.77	0.68	0.61	0.55	
		SLS	L/200	23.11	8.23	4.23	2.62	1.82	1.36	1.06	0.86	0.71	0.60	0.52	0.46
			L/250	18.50	6.61	3.40	2.12	1.48	1.11	0.87	0.71	0.59	0.50	0.44	0.39
		II	ULS 2/3	5.26	3.54	2.69	2.10	1.58	1.26	1.04	0.89	0.77	0.68	0.61	0.55
			ULS 1/3	2.78	1.88	1.51	1.30	1.13	1.02	0.92	0.85	0.77	0.68	0.61	0.55
	SLS		L/200	23.11	8.23	4.23	2.62	1.82	1.36	1.06	0.86	0.71	0.60	0.52	0.46
			L/250	18.50	6.61	3.40	2.12	1.48	1.11	0.87	0.71	0.59	0.50	0.44	0.39
	III		ULS 2/3	5.26	3.54	2.31	1.62	1.25	1.01	0.86	0.74	0.66	0.59	0.54	0.50
			ULS 1/3	2.78	1.88	1.49	1.27	1.13	1.01	0.86	0.74	0.66	0.59	0.54	0.50
		SLS	L/200	23.11	8.23	4.23	2.62	1.82	1.36	1.06	0.86	0.71	0.60	0.52	0.46
			L/250	18.50	6.61	3.40	2.12	1.48	1.11	0.87	0.71	0.59	0.50	0.44	0.39

Table 2.15. Maximum allowable wind suction [kN/m²] for the length of span made of Ruukki SP2C 100/60PIR panel

=> Ruukki SP2C 100/60 PIR, group II (light colours), multi-span panels, span length of sandwich panels is 3m ($11,1 \text{ kg/m}^2 \Rightarrow 0,11 \text{ kN/m}^2$)

-Maximum allowable snow load for sandwich panel from table 2.14 is $1,26 \text{ kN/m}^2$

The biggest snow load on sandwich panel from calculation on the construction is $1,03 \text{ kN/m}^2$

$1,03 \text{ kN/m}^2 < 1,26 \text{ kN/m}^2 \Rightarrow$ satisfied

-Maximum allowable wind suction for sandwich panel from table 2.15 is $1,13 \text{ kN/m}^2$

The biggest wind suction on sandwich panel from calculation on the construction is $1,07 \text{ kN/m}^2$

$1,07 \text{ kN/m}^2 < 1,13 \text{ kN/m}^2 \Rightarrow$ satisfied

3. Construction calculation

The design of the structure was performed in the Scia Engineer 19.1 software package with a 3D structure model.

3.1 Presentation of structure model

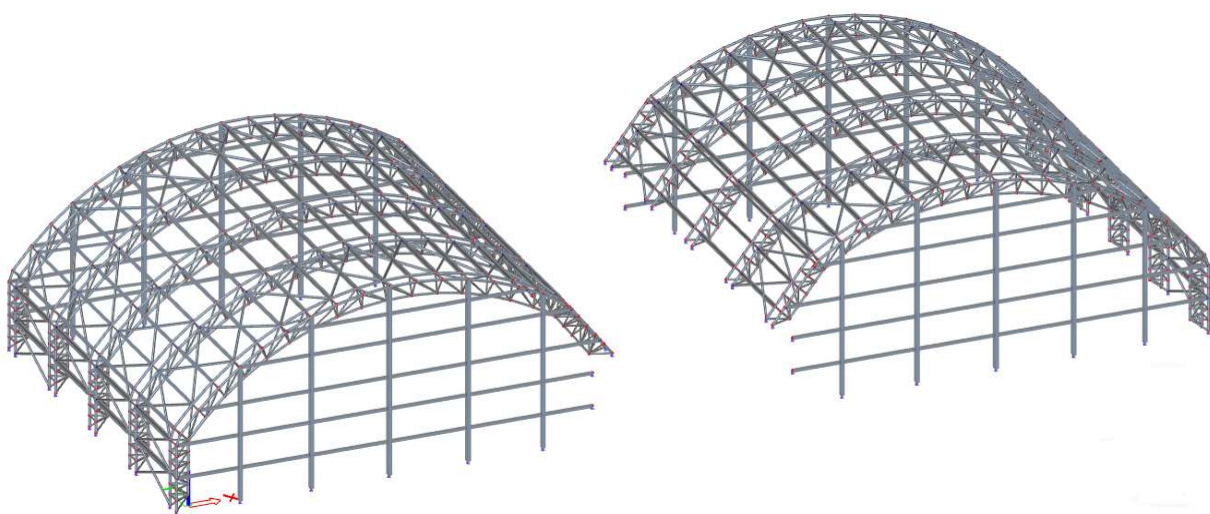

Figure 3.1. 3D view of the model

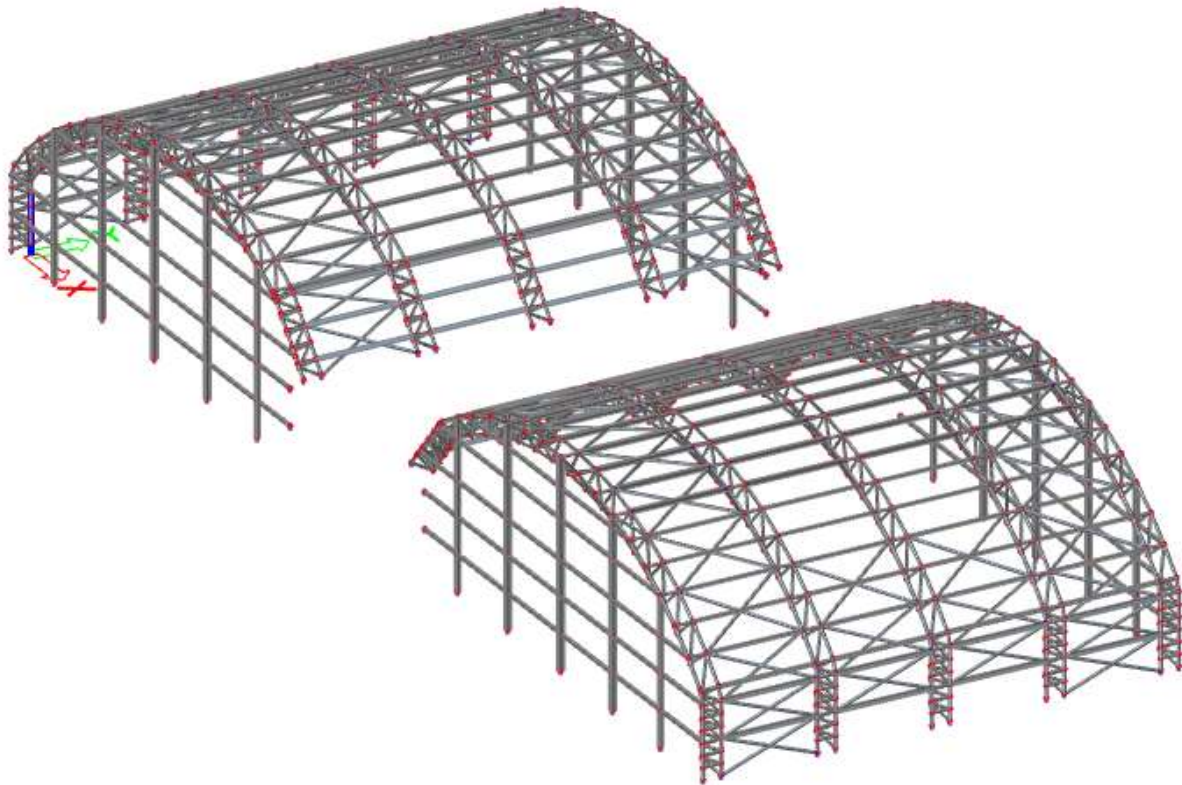

Figure 3.2. 3D side view of the model

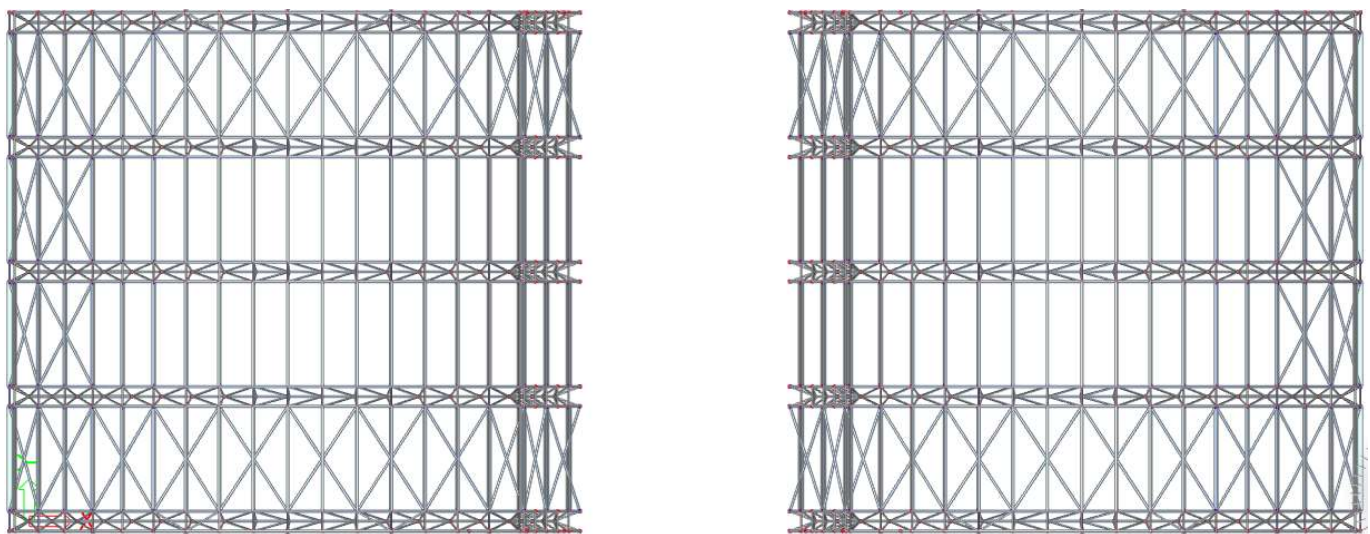

Figure 3.3. Top view of the model

3.2 Display of individual load on the structure

All loads are placed to the structure as a surface load on the panels. Then panels transferred that load to the rest of the structure.

3.2.1 self weight

The self weight of the construction is set automatically in the program.

3.2.2. Permanent load

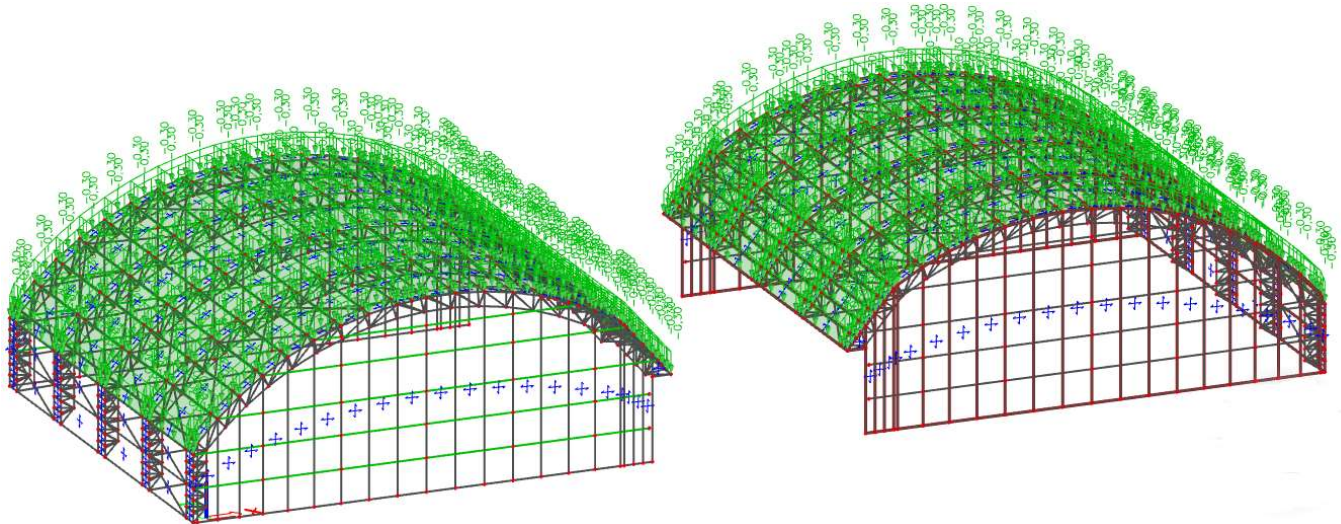

Figure 3.4. Permanent load

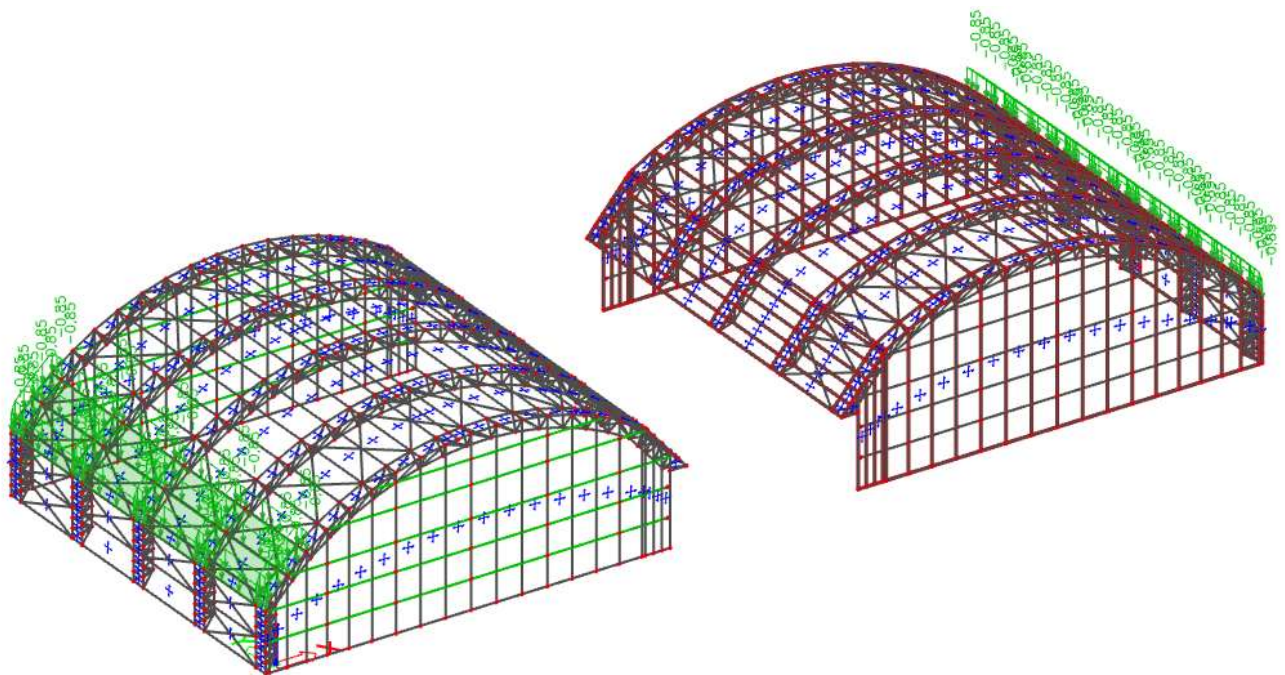

Figure 3.5. Permanent load (workers + instalation) (1)

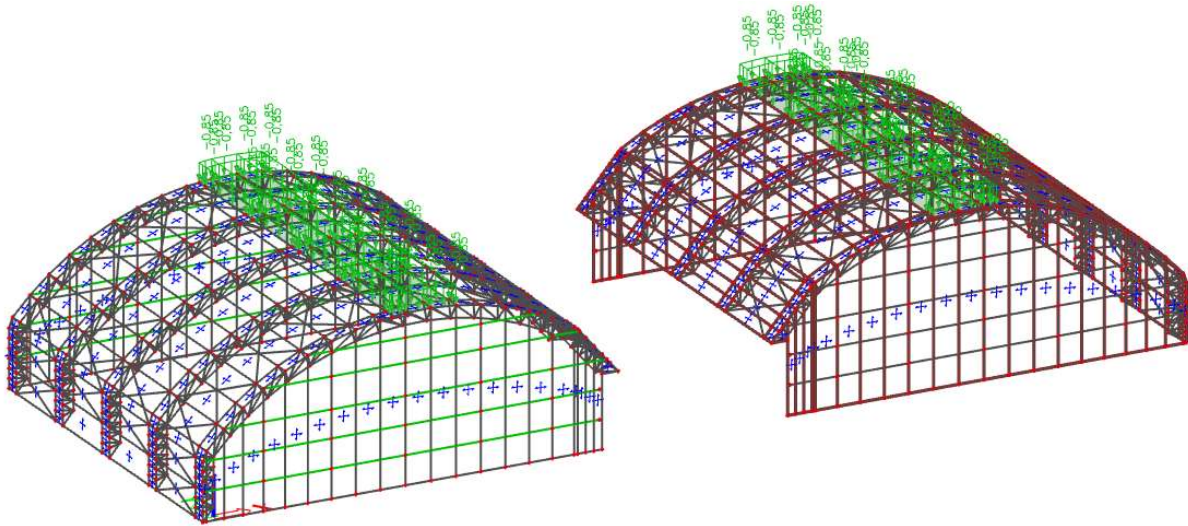

Figure 3.6. Permanent load (workers + instalation) (2)

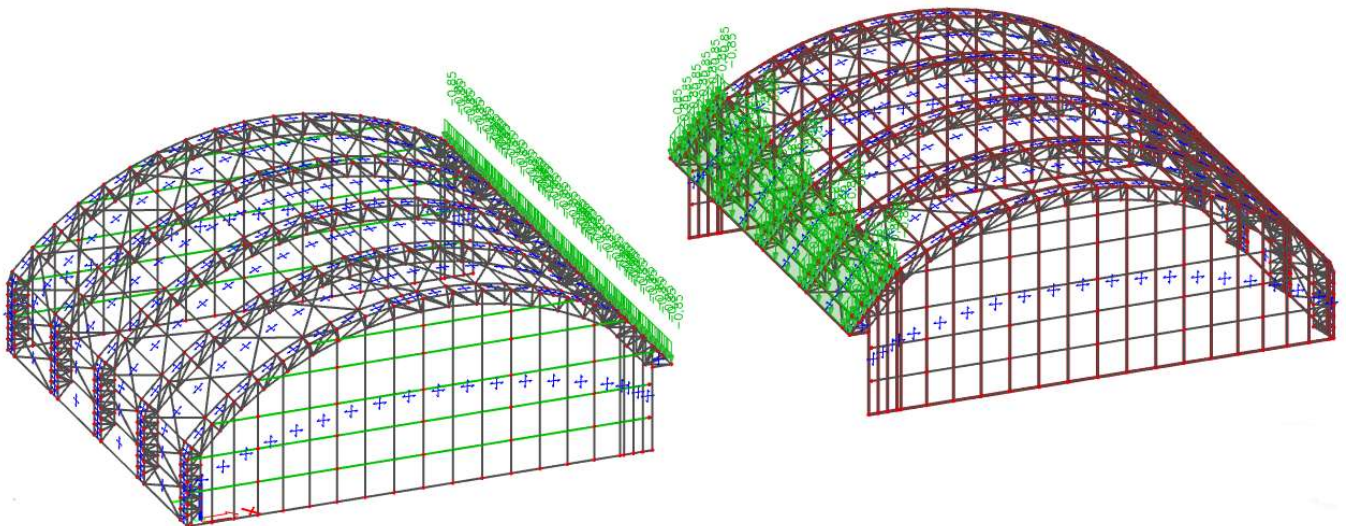

Figure 3.7. Permanent load (workers + instalation) (3)

3.2.3. Snow load

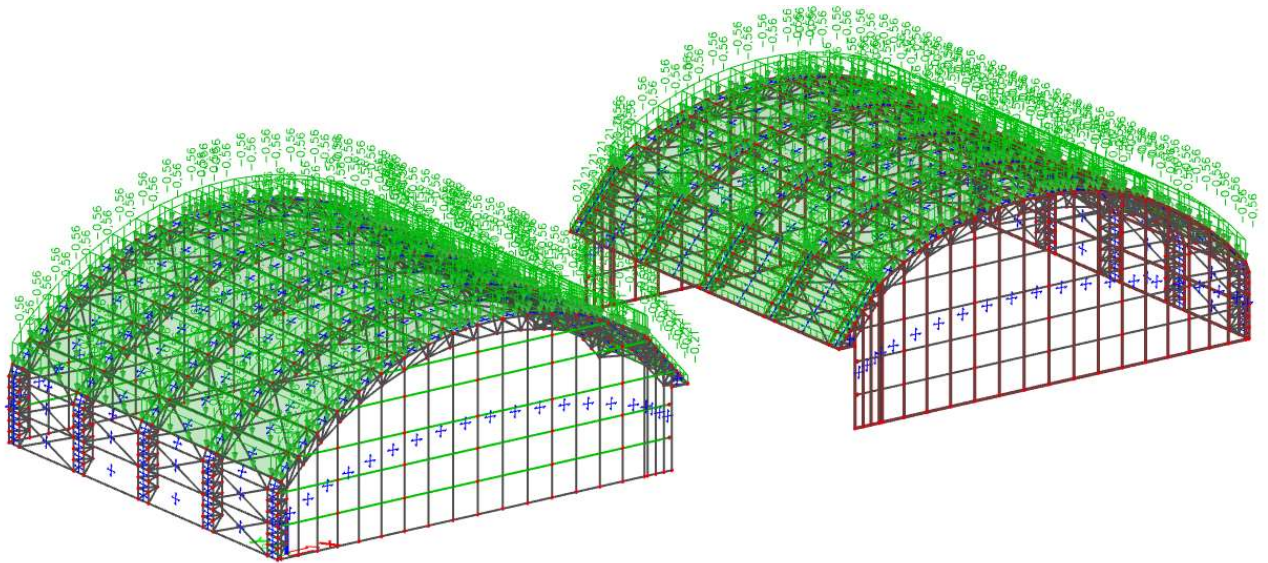

Figure 3.8. Snow load 1

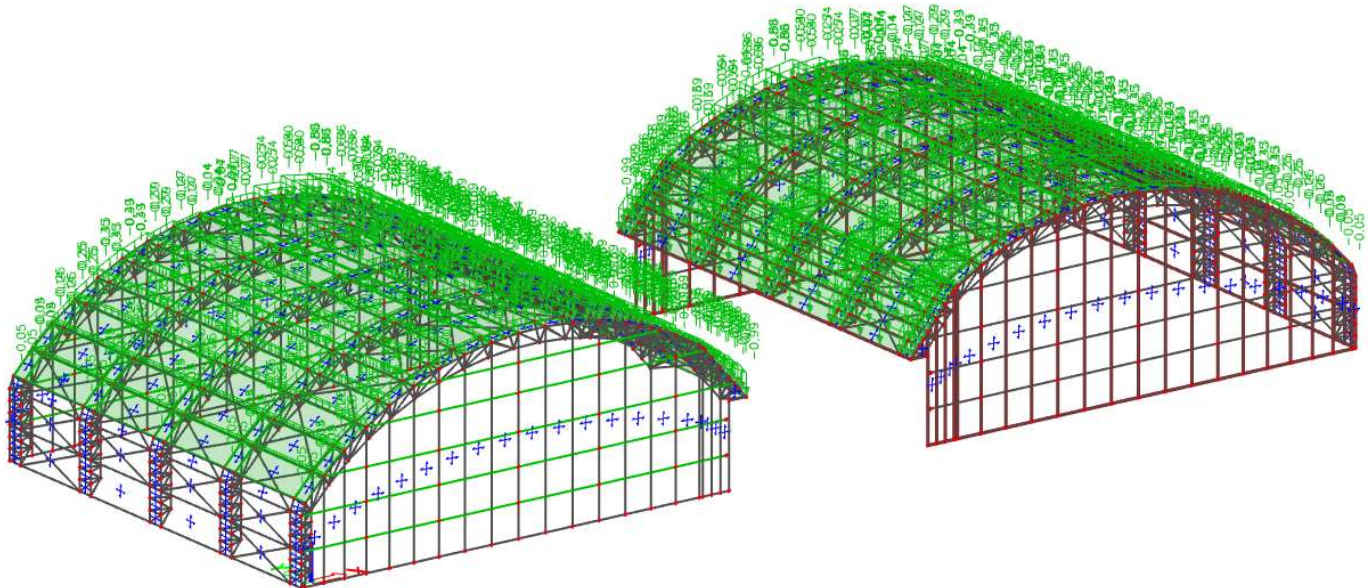

Figure 3.9. Snow load 2

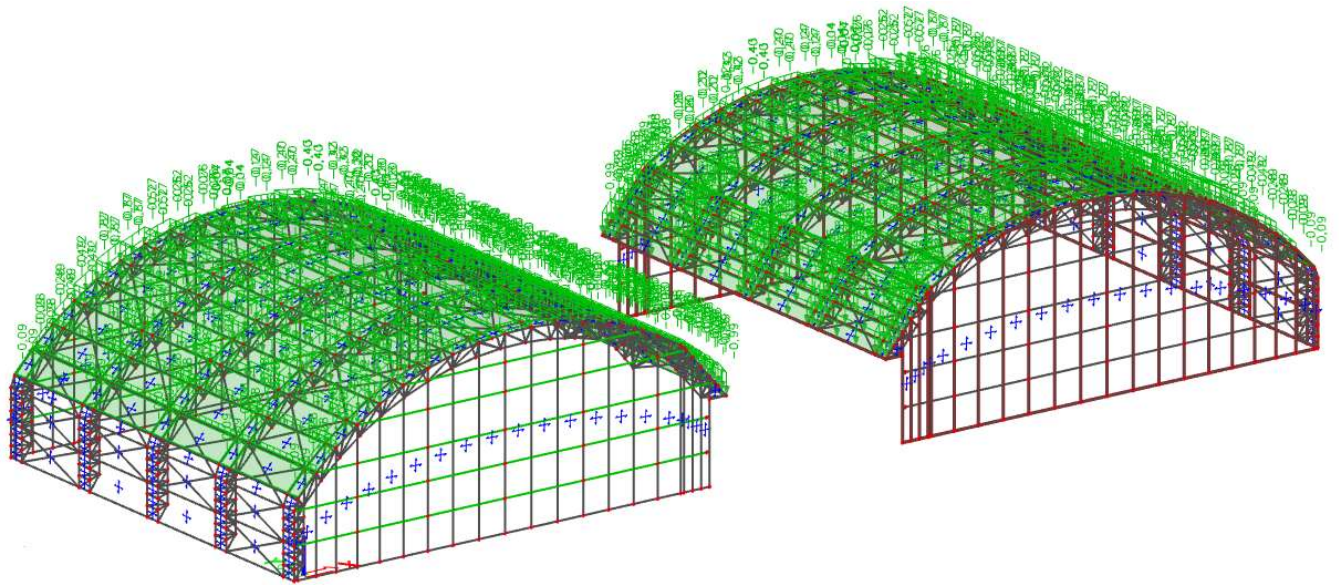

Figure 3.10. Snow load 3

3.2.4. wind load (w_1)

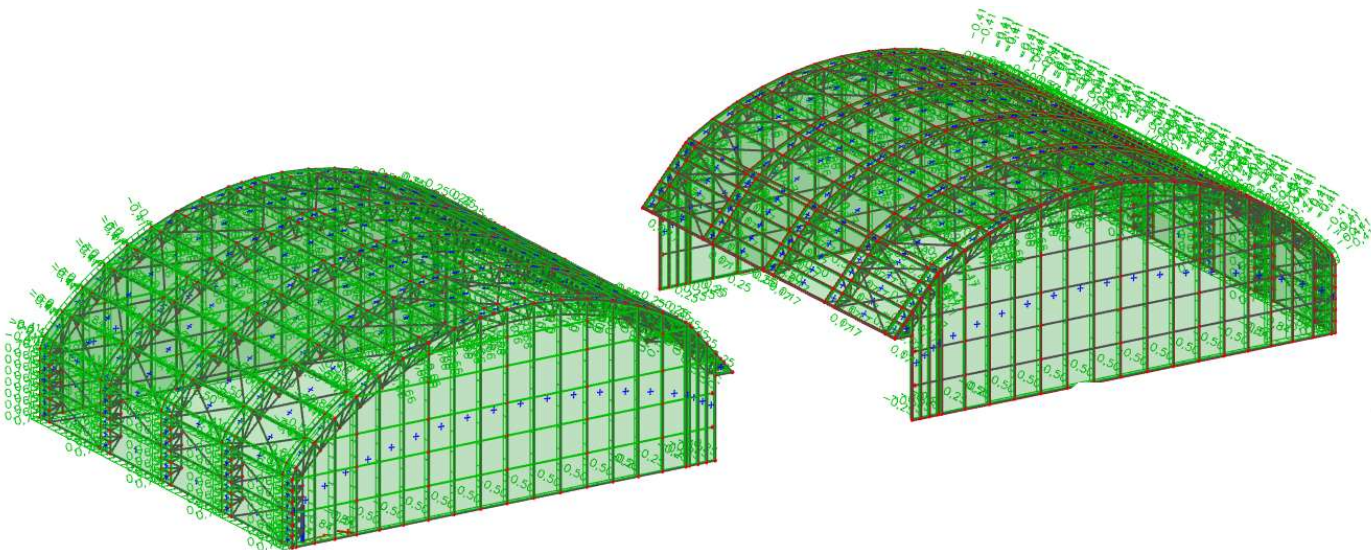

Figure 3.11. wind load w_1

3.2.5. wind load (w_2)

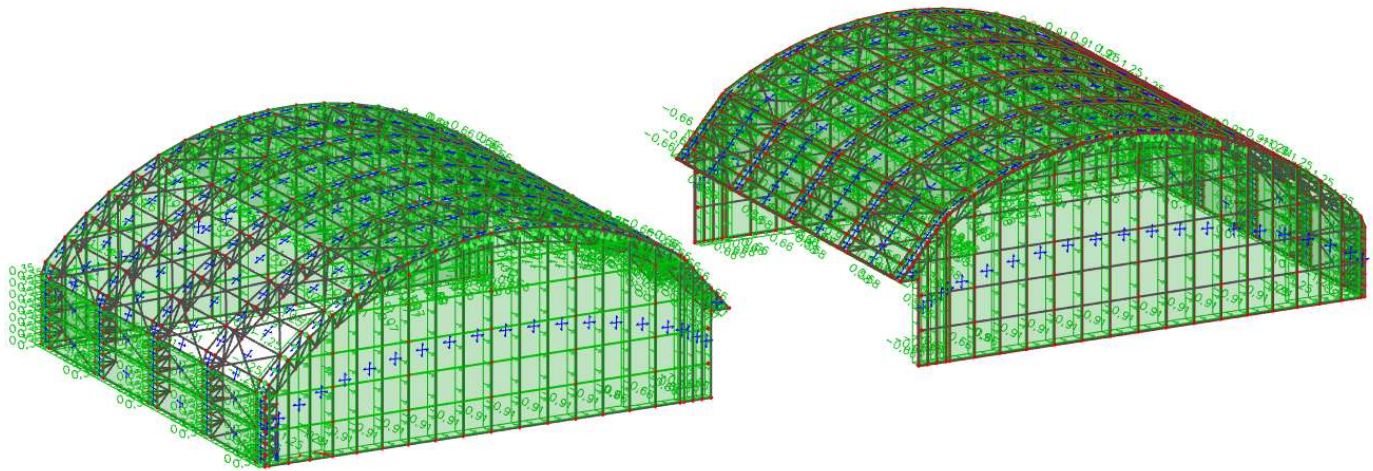

Figure 3.12. wind load w_2

3.2.6. Thermal actions

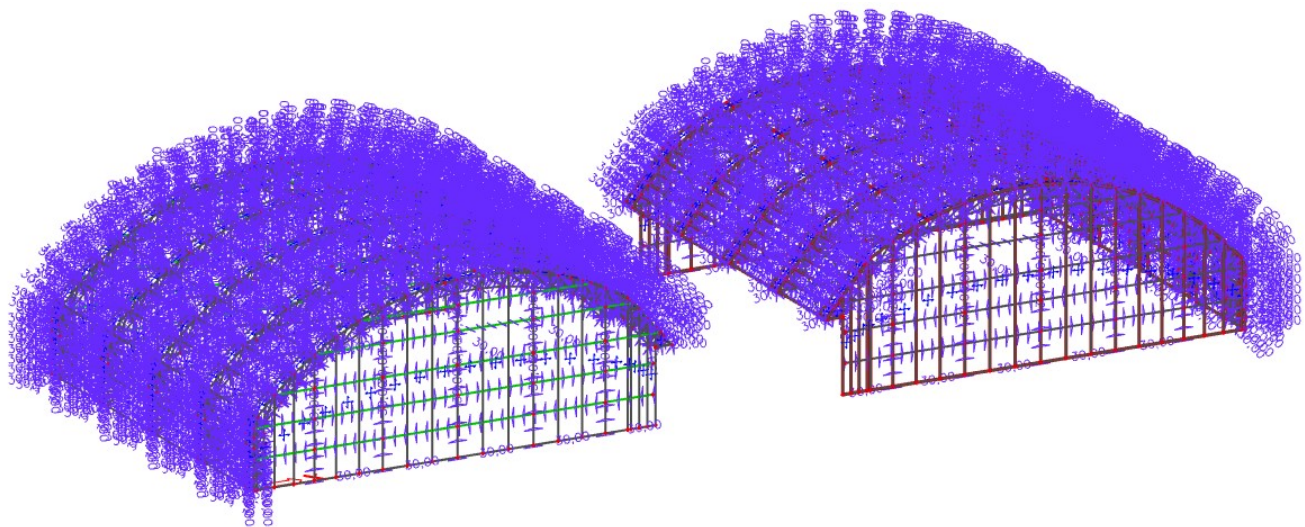

Figure 3.13. Positive temperature change (+30 °C)

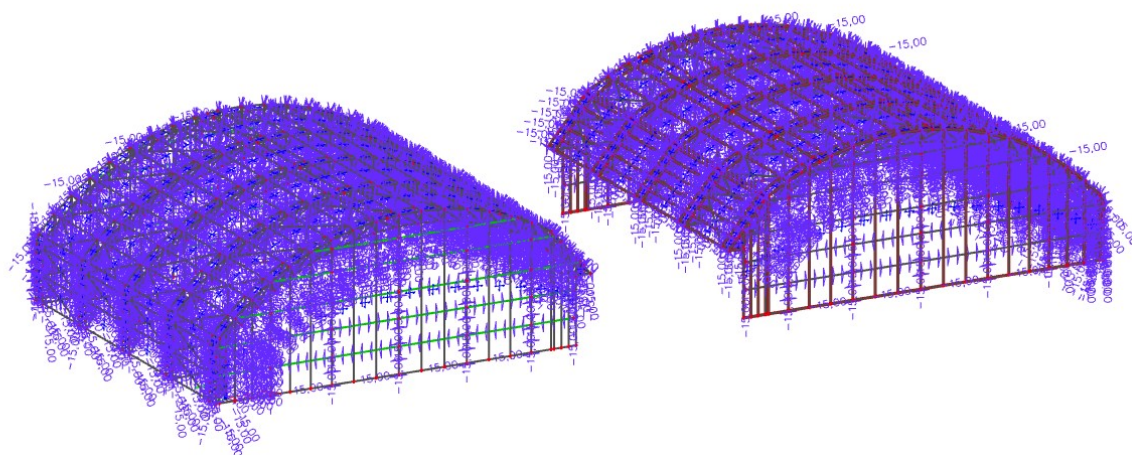

Figure 3.13. Negative temperature change (-15°C)

3.3 Combination of actions

Combinations of actions were created for the ultimate limit state and serviceability limit state using the computer program Scia Engineer 19.1.

3.3.1 Ultimate limit state (ULS)

Combinations

Name	Description	Type	Load cases	Coeff. [-]
gsn1	uls	Envelope - ultimate	LC1 - Self weight snow wind 0.2 constant load work+inst1 temperature positive	1,35 1,50 0,90 1,35 1,05 0,90
gsn2	uls	Envelope - ultimate	LC1 - Self weight snow wind -0.3 constant load work+inst1 temperature positive	1,35 1,50 0,90 1,35 1,05 0,90
gsn3	uls	Envelope - ultimate	LC1 - Self weight snow wind 0.2 constant load work+inst2 temperature positive	1,35 1,50 0,90 1,35 1,05 0,90
gsn4	uls	Envelope - ultimate	LC1 - Self weight snow wind -0.3 constant load work+inst2 temperature positive	1,35 1,50 0,90 1,35 1,05 0,90
gsn5	uls	Envelope - ultimate	LC1 - Self weight snow wind 0.2 constant load work+inst3 temperature positive	1,35 1,50 0,90 1,35 1,05 0,90
gsn6	uls	Envelope - ultimate	LC1 - Self weight snow wind -0.3 constant load work+inst3 temperature positive	1,35 1,50 0,90 1,35 1,05 0,90
gsn7	uls	Envelope - ultimate	LC1 - Self weight snow2 (1) wind 0.2 constant load work+inst1 temperature positive	1,35 1,50 0,90 1,35 1,05 0,90
gsn8	uls	Envelope - ultimate	LC1 - Self weight snow2 (1) wind -0.3 constant load work+inst1 temperature positive	1,35 1,50 0,90 1,35 1,05 0,90
gsn9	uls	Envelope - ultimate	LC1 - Self weight snow2 (1) wind 0.2 constant load work+inst2 temperature positive	1,35 1,50 0,90 1,35 1,05 0,90
gsn10	uls	Envelope - ultimate	LC1 - Self weight snow2 (1) wind -0.3 constant load work+inst2 temperature positive	1,35 1,50 0,90 1,35 1,05 0,90
gsn11	uls	Envelope - ultimate	LC1 - Self weight snow2 (1) wind 0.2 constant load work+inst3 temperature positive	1,35 1,50 0,90 1,35 1,05 0,90
gsn12	uls	Envelope - ultimate	LC1 - Self weight snow2 (1) wind -0.3 constant load work+inst3 temperature positive	1,35 1,50 0,90 1,35 1,05 0,90
gsn13	uls	Envelope - ultimate	LC1 - Self weight wind 0.2 constant load work+inst1 snow2 (2) temperature positive	1,35 0,90 1,35 1,05 1,50 0,90
gsn14	uls	Envelope - ultimate	LC1 - Self weight wind -0.3 constant load work+inst1 snow2 (2) temperature positive	1,35 0,90 1,35 1,05 1,50 0,90
gsn15	uls	Envelope - ultimate	LC1 - Self weight wind 0.2 constant load snow2 (2) work+inst2 temperature positive	1,35 0,90 1,35 1,50 1,05 0,90

gsn16	uls	Envelope - ultimate	LC1 - Self weight wind -0.3 constant load snow2 (2) work+inst2 temperature positive	1,35 0,90 1,35 1,50 1,05 0,90	gsn24	uls	Envelope - ultimate	LC1 - Self weight snow wind -0.3 constant load work+inst3 temperature positive	1,35 0,75 1,50 1,35 1,05 0,90
gsn17	uls	Envelope - ultimate	LC1 - Self weight wind 0.2 constant load snow2 (2) work+inst3 temperature positive	1,35 0,90 1,35 1,50 1,05 0,90	gsn25	uls	Envelope - ultimate	LC1 - Self weight snow2 (1) wind 0.2 constant load work+inst1 temperature positive	1,35 0,75 1,50 1,35 1,05 0,90
gsn18	uls	Envelope - ultimate	LC1 - Self weight wind -0.3 constant load snow2 (2) work+inst3 temperature positive	1,35 0,90 1,35 1,50 1,05 0,90	gsn26	uls	Envelope - ultimate	LC1 - Self weight snow2 (1) wind 0.2 constant load work+inst2 temperature positive	1,35 0,75 1,50 1,35 1,05 0,90
gsn19	uls	Envelope - ultimate	LC1 - Self weight snow wind 0.2 constant load work+inst1 temperature positive	1,35 0,75 1,50 1,35 1,05 0,90	gsn27	uls	Envelope - ultimate	LC1 - Self weight snow2 (1) wind 0.2 constant load work+inst3 temperature positive	1,35 0,75 1,50 1,35 1,05 0,90
gsn20	uls	Envelope - ultimate	LC1 - Self weight snow wind 0.2 constant load work+inst2 temperature positive	1,35 0,75 1,50 1,35 1,05 0,90	gsn28	uls	Envelope - ultimate	LC1 - Self weight snow2 (1) wind -0.3 constant load work+inst1 temperature positive	1,35 0,75 1,50 1,35 1,05 0,90
gsn21	uls	Envelope - ultimate	LC1 - Self weight snow wind 0.2 constant load work+inst3 temperature positive	1,35 0,75 1,50 1,35 1,05 0,90	gsn29	uls	Envelope - ultimate	LC1 - Self weight snow2 (1) wind -0.3 constant load work+inst2 temperature positive	1,35 0,75 1,50 1,35 1,05 0,90
gsn22	uls	Envelope - ultimate	LC1 - Self weight snow wind -0.3 constant load work+inst1 temperature positive	1,35 0,75 1,50 1,35 1,05 0,90	gsn30	uls	Envelope - ultimate	LC1 - Self weight snow2 (1) wind -0.3 constant load work+inst3 temperature positive	1,35 0,75 1,50 1,35 1,05 0,90
gsn23	uls	Envelope - ultimate	LC1 - Self weight snow wind -0.3 constant load work+inst2 temperature positive	1,35 0,75 1,50 1,35 1,05 0,90	gsn31	uls	Envelope - ultimate	LC1 - Self weight wind 0.2 constant load work+inst1 snow2 (2) temperature positive	1,35 1,50 1,35 1,05 0,75 0,90

gsn32	uls	Envelope - ultimate	LC1 - Self weight	1,35	gsn41	uls	Envelope - ultimate	LC1 - Self weight	1,35
			wind 0.2	1,50				snow2 (1)	1,50
			constant load	1,35				constant load	1,35
			snow2 (2)	0,75				work+inst2	1,05
			work+inst2	1,05				temperature positive	0,90
			temperature positive	0,90	gsn42	uls	Envelope - ultimate	LC1 - Self weight	1,35
gsn33	uls	Envelope - ultimate	LC1 - Self weight	1,35				snow2 (1)	1,50
			wind 0.2	1,50				constant load	1,35
			constant load	1,35				work+inst3	1,05
			snow2 (2)	0,75				temperature positive	0,90
			work+inst3	1,05	gsn43	uls	Envelope - ultimate	LC1 - Self weight	1,35
			temperature positive	0,90				constant load	1,35
gsn34	uls	Envelope - ultimate	LC1 - Self weight	1,35				work+inst1	1,05
			wind -0.3	1,50				snow2 (2)	1,50
			constant load	1,35				temperature positive	0,90
			work+inst1	1,05	gsn44	uls	Envelope - ultimate	LC1 - Self weight	1,35
			snow2 (2)	0,75				constant load	1,35
			temperature positive	0,90				snow2 (2)	1,50
gsn35	uls	Envelope - ultimate	LC1 - Self weight	1,35				work+inst2	1,05
			wind -0.3	1,50				temperature positive	0,90
			constant load	1,35	gsn45	uls	Envelope - ultimate	LC1 - Self weight	1,35
			snow2 (2)	0,75				constant load	1,35
			work+inst2	1,05				snow2 (2)	1,50
			temperature positive	0,90				work+inst3	1,05
gsn36	uls	Envelope - ultimate	LC1 - Self weight	1,35				temperature positive	0,90
			wind -0.3	1,50	gsn45 uplift	uls	Envelope - ultimate	LC1 - Self weight	1,00
			constant load	1,35				wind -0.3	1,50
			snow2 (2)	0,75				constant load	1,00
			work+inst3	1,05				temperature positive	0,90
			temperature positive	0,90	gsn46	uls	Envelope - ultimate	LC1 - Self weight	1,35
gsn37	uls	Envelope - ultimate	LC1 - Self weight	1,35				snow	1,50
			snow	1,50				wind 0.2	0,90
			constant load	1,35				constant load	1,35
			work+inst1	1,05				work+inst1	1,05
			temperature positive	0,90				temperature negative	0,90
gsn38	uls	Envelope - ultimate	LC1 - Self weight	1,35	gsn47	uls	Envelope - ultimate	LC1 - Self weight	1,35
			snow	1,50				snow	1,50
			constant load	1,35				wind -0.3	0,90
			work+inst2	1,05				constant load	1,35
			temperature positive	0,90				work+inst1	1,05
gsn39	uls	Envelope - ultimate	LC1 - Self weight	1,35				temperature negative	0,90
			snow	1,50	gsn48	uls	Envelope - ultimate	LC1 - Self weight	1,35
			constant load	1,35				snow	1,50
			work+inst3	1,05				wind 0.2	0,90
			temperature positive	0,90				constant load	1,35
gsn40	uls	Envelope - ultimate	LC1 - Self weight	1,35				work+inst2	1,05
			snow2 (1)	1,50				temperature negative	0,90
			constant load	1,35					
			work+inst1	1,05					
			temperature positive	0,90					

gsn49	uls	Envelpe - ultimate	LC1 - Self weight	1,35	gsn57	uls	Envelpe - ultimate	LC1 - Self weight	1,35
			snow	1,50				snow2 (1)	1,50
			wind -0.3	0,90				wind -0.3	0,90
			constant load	1,35				constant load	1,35
			work+inst2	1,05				work+inst3	1,05
			temperature negative	0,90				temperature negative	0,90
gsn50	uls	Envelpe - ultimate	LC1 - Self weight	1,35	gsn58	uls	Envelpe - ultimate	LC1 - Self weight	1,35
			snow	1,50				wind 0.2	0,90
			wind 0.2	0,90				constant load	1,35
			constant load	1,35				work+inst1	1,05
			work+inst3	1,05				snow2 (2)	1,50
			temperature negative	0,90				temperature negative	0,90
gsn51	uls	Envelpe - ultimate	LC1 - Self weight	1,35	gsn59	uls	Envelpe - ultimate	LC1 - Self weight	1,35
			snow	1,50				wind -0.3	0,90
			wind -0.3	0,90				constant load	1,35
			constant load	1,35				work+inst1	1,05
			work+inst3	1,05				snow2 (2)	1,50
			temperature negative	0,90				temperature negative	0,90
gsn52	uls	Envelpe - ultimate	LC1 - Self weight	1,35	gsn60	uls	Envelpe - ultimate	LC1 - Self weight	1,35
			snow2 (1)	1,50				wind 0.2	0,90
			wind 0.2	0,90				constant load	1,35
			constant load	1,35				snow2 (2)	1,50
			work+inst1	1,05				work+inst2	1,05
			temperature negative	0,90				temperature negative	0,90
gsn53	uls	Envelpe - ultimate	LC1 - Self weight	1,35	gsn61	uls	Envelpe - ultimate	LC1 - Self weight	1,35
			snow2 (1)	1,50				wind -0.3	0,90
			wind -0.3	0,90				constant load	1,35
			constant load	1,35				snow2 (2)	1,50
			work+inst1	1,05				work+inst2	1,05
			temperature negative	0,90				temperature negative	0,90
gsn54	uls	Envelpe - ultimate	LC1 - Self weight	1,35	gsn62	uls	Envelpe - ultimate	LC1 - Self weight	1,35
			snow2 (1)	1,50				wind 0.2	0,90
			wind 0.2	0,90				constant load	1,35
			constant load	1,35				snow2 (2)	1,50
			work+inst2	1,05				work+inst3	1,05
			temperature negative	0,90				temperature negative	0,90
gsn55	uls	Envelpe - ultimate	LC1 - Self weight	1,35	gsn63	uls	Envelpe - ultimate	LC1 - Self weight	1,35
			snow2 (1)	1,50				wind -0.3	0,90
			wind -0.3	0,90				constant load	1,35
			constant load	1,35				snow2 (2)	1,50
			work+inst2	1,05				work+inst3	1,05
			temperature negative	0,90				temperature negative	0,90
gsn56	uls	Envelpe - ultimate	LC1 - Self weight	1,35	gsn64	uls	Envelpe - ultimate	LC1 - Self weight	1,35
			snow2 (1)	1,50				snow	0,75
			wind 0.2	0,90				wind 0.2	1,50
			constant load	1,35				constant load	1,35
			work+inst3	1,05				work+inst1	1,05
			temperature negative	0,90				temperature negative	0,90

gsn65	uls	Envebpe - ultimate	LC1 - Self weight	1,35	gsn73	uls	Envebpe - ultimate	LC1 - Self weight	1,35
			snow	0,75				snow2 (1)	0,75
			wind 0.2	1,50				wind -0.3	1,50
			constant load	1,35				constant load	1,35
			work+inst2	1,05				work+inst1	1,05
			temperature negative	0,90				temperature negative	0,90
gsn66	uls	Envebpe - ultimate	LC1 - Self weight	1,35	gsn74	uls	Envebpe - ultimate	LC1 - Self weight	1,35
			snow	0,75				snow2 (1)	0,75
			wind 0.2	1,50				wind -0.3	1,50
			constant load	1,35				constant load	1,35
			work+inst3	1,05				work+inst2	1,05
			temperature negative	0,90				temperature negative	0,90
gsn67	uls	Envebpe - ultimate	LC1 - Self weight	1,35	gsn75	uls	Envebpe - ultimate	LC1 - Self weight	1,35
			snow	0,75				snow2 (1)	0,75
			wind -0.3	1,50				wind -0.3	1,50
			constant load	1,35				constant load	1,35
			work+inst1	1,05				work+inst3	1,05
			temperature negative	0,90				temperature negative	0,90
gsn68	uls	Envebpe - ultimate	LC1 - Self weight	1,35	gsn76	uls	Envebpe - ultimate	LC1 - Self weight	1,35
			snow	0,75				wind 0.2	1,50
			wind -0.3	1,50				constant load	1,35
			constant load	1,35				work+inst1	1,05
			work+inst2	1,05				snow2 (2)	0,75
			temperature negative	0,90				temperature negative	0,90
gsn69	uls	Envebpe - ultimate	LC1 - Self weight	1,35	gsn77	uls	Envebpe - ultimate	LC1 - Self weight	1,35
			snow	0,75				wind 0.2	1,50
			wind -0.3	1,50				constant load	1,35
			constant load	1,35				snow2 (2)	0,75
			work+inst3	1,05				work+inst2	1,05
			temperature negative	0,90				temperature negative	0,90
gsn70	uls	Envebpe - ultimate	LC1 - Self weight	1,35	gsn78	uls	Envebpe - ultimate	LC1 - Self weight	1,35
			snow2 (1)	0,75				wind 0.2	1,50
			wind 0.2	1,50				constant load	1,35
			constant load	1,35				snow2 (2)	0,75
			work+inst1	1,05				work+inst3	1,05
			temperature negative	0,90				temperature negative	0,90
gsn71	uls	Envebpe - ultimate	LC1 - Self weight	1,35	gsn79	uls	Envebpe - ultimate	LC1 - Self weight	1,35
			snow2 (1)	0,75				wind -0.3	1,50
			wind 0.2	1,50				constant load	1,35
			constant load	1,35				work+inst1	1,05
			work+inst2	1,05				snow2 (2)	0,75
			temperature negative	0,90				temperature negative	0,90
gsn72	uls	Envebpe - ultimate	LC1 - Self weight	1,35	gsn80	uls	Envebpe - ultimate	LC1 - Self weight	1,35
			snow2 (1)	0,75				wind -0.3	1,50
			wind 0.2	1,50				constant load	1,35
			constant load	1,35				snow2 (2)	0,75
			work+inst3	1,05				work+inst2	1,05
			temperature negative	0,90				temperature negative	0,90

gsn81	uls	Envelope - ultimate	LC1 - Self weight	1,35	gsn48 upift1	uls	Envelope - ultimate	LC1 - Self weight	1,00
			wind -0.3	1,50				wind -0.3	1,50
			constant load	1,35				constant load	1,00
			snow2 (2)	0,75				temperature negative	0,90
			work+inst3	1,05	gsn91	uls	Envelope - ultimate	LC1 - Self weight	1,35
			temperature negative	0,90				snow	1,50
gsn82	uls	Envelope - ultimate	LC1 - Self weight	1,35				wind 0.2	0,90
			snow	1,50				constant load	1,35
			constant load	1,35				work+inst1	1,05
			work+inst1	1,05				temperature positive	0,00
			temperature negative	0,90	gsn92	uls	Envelope - ultimate	LC1 - Self weight	1,35
gsn83	uls	Envelope - ultimate	LC1 - Self weight	1,35				snow	1,50
			snow	1,50				wind -0.3	0,90
			constant load	1,35				constant load	1,35
			work+inst2	1,05				work+inst1	1,05
			temperature negative	0,90				temperature positive	0,00
gsn84	uls	Envelope - ultimate	LC1 - Self weight	1,35	gsn93	uls	Envelope - ultimate	LC1 - Self weight	1,35
			snow	1,50				snow	1,50
			constant load	1,35				wind 0.2	0,90
			work+inst3	1,05				constant load	1,35
			temperature negative	0,90				work+inst2	1,05
gsn85	uls	Envelope - ultimate	LC1 - Self weight	1,35				temperature positive	0,00
			snow2 (1)	1,50	gsn94	uls	Envelope - ultimate	LC1 - Self weight	1,35
			constant load	1,35				snow	1,50
			work+inst1	1,05				wind -0.3	0,90
			temperature negative	0,90				constant load	1,35
gsn86	uls	Envelope - ultimate	LC1 - Self weight	1,35				work+inst2	1,05
			snow2 (1)	1,50				temperature positive	0,00
			constant load	1,35	gsn95	uls	Envelope - ultimate	LC1 - Self weight	1,35
			work+inst2	1,05				snow	1,50
			temperature negative	0,90				wind 0.2	0,90
gsn87	uls	Envelope - ultimate	LC1 - Self weight	1,35				constant load	1,35
			snow2 (1)	1,50				work+inst3	1,05
			constant load	1,35				temperature positive	0,00
			work+inst3	1,05	gsn96	uls	Envelope - ultimate	LC1 - Self weight	1,35
			temperature negative	0,90				snow	1,50
gsn88	uls	Envelope - ultimate	LC1 - Self weight	1,35				wind -0.3	0,90
			constant load	1,35				constant load	1,35
			work+inst1	1,05				work+inst3	1,05
			snow2 (2)	1,50				temperature positive	0,00
			temperature negative	0,90	gsn96	uls	Envelope - ultimate	LC1 - Self weight	1,35
gsn89	uls	Envelope - ultimate	LC1 - Self weight	1,35				snow	1,50
			constant load	1,35				wind -0.3	0,90
			snow2 (2)	1,50				constant load	1,35
			work+inst2	1,05				work+inst3	1,05
			temperature negative	0,90				temperature positive	0,00
gsn90	uls	Envelope - ultimate	LC1 - Self weight	1,35	gsn97	uls	Envelope - ultimate	LC1 - Self weight	1,35
			constant load	1,35				snow2 (1)	1,50
			snow2 (2)	1,50				wind 0.2	0,90
			work+inst3	1,05				constant load	1,35
			temperature negative	0,90				work+inst1	1,05
								temperature positive	0,00

gsn98	uls	Envelope - ultimate	LC1 - Self weight	1,35	gsn106	uls	Envelope - ultimate	LC1 - Self weight	1,35
			snow2 (1)	1,50				wind -0.3	0,90
			wind -0.3	0,90				constant load	1,35
			constant load	1,35				snow2 (2)	1,50
			work+inst1	1,05				work+inst2	1,05
			temperature positive	0,00				temperature positive	0,00
gsn99	uls	Envelope - ultimate	LC1 - Self weight	1,35	gsn107	uls	Envelope - ultimate	LC1 - Self weight	1,35
			snow2 (1)	1,50				wind 0.2	0,90
			wind 0.2	0,90				constant load	1,35
			constant load	1,35				snow2 (2)	1,50
			work+inst2	1,05				work+inst3	1,05
			temperature positive	0,00				temperature positive	0,00
gsn100	uls	Envelope - ultimate	LC1 - Self weight	1,35	gsn108	uls	Envelope - ultimate	LC1 - Self weight	1,35
			snow2 (1)	1,50				wind -0.3	0,90
			wind -0.3	0,90				constant load	1,35
			constant load	1,35				snow2 (2)	1,50
			work+inst2	1,05				work+inst3	1,05
			temperature positive	0,00				temperature positive	0,00
gsn101	uls	Envelope - ultimate	LC1 - Self weight	1,35	gsn109	uls	Envelope - ultimate	LC1 - Self weight	1,35
			snow2 (1)	1,50				snow	0,75
			wind 0.2	0,90				wind 0.2	1,50
			constant load	1,35				constant load	1,35
			work+inst3	1,05				work+inst1	1,05
			temperature positive	0,00				temperature positive	0,00
gsn102	uls	Envelope - ultimate	LC1 - Self weight	1,35	gsn110	uls	Envelope - ultimate	LC1 - Self weight	1,35
			snow2 (1)	1,50				snow	0,75
			wind -0.3	0,90				wind 0.2	1,50
			constant load	1,35				constant load	1,35
			work+inst3	1,05				work+inst2	1,05
			temperature positive	0,00				temperature positive	0,00
gsn103	uls	Envelope - ultimate	LC1 - Self weight	1,35	gsn111	uls	Envelope - ultimate	LC1 - Self weight	1,35
			wind 0.2	0,90				snow	0,75
			constant load	1,35				wind 0.2	1,50
			work+inst1	1,05				constant load	1,35
			snow2 (2)	1,50				work+inst3	1,05
			temperature positive	0,00				temperature positive	0,00
gsn104	uls	Envelope - ultimate	LC1 - Self weight	1,35	gsn112	uls	Envelope - ultimate	LC1 - Self weight	1,35
			wind -0.3	0,90				snow	0,75
			constant load	1,35				wind -0.3	1,50
			work+inst1	1,05				constant load	1,35
			snow2 (2)	1,50				work+inst1	1,05
			temperature positive	0,00				temperature positive	0,00
gsn105	uls	Envelope - ultimate	LC1 - Self weight	1,35	gsn113	uls	Envelope - ultimate	LC1 - Self weight	1,35
			wind 0.2	0,90				snow	0,75
			constant load	1,35				wind -0.3	1,50
			snow2 (2)	1,50				constant load	1,35
			work+inst2	1,05				work+inst2	1,05
			temperature positive	0,00				temperature positive	0,00

gsn114	uls	Envelope - ultimate	LC1 - Self weight	1,35	gsn122	uls	Envelope - ultimate	LC1 - Self weight	1,35
			snow	0,75				wind 0.2	1,50
			wind -0.3	1,50				constant load	1,35
			constant load	1,35				snow2 (2)	0,75
			work+inst3	1,05				work+inst2	1,05
			temperature positive	0,00				temperature positive	0,00
gsn115	uls	Envelope - ultimate	LC1 - Self weight	1,35	gsn123	uls	Envelope - ultimate	LC1 - Self weight	1,35
			snow2 (1)	0,75				wind 0.2	1,50
			wind 0.2	1,50				constant load	1,35
			constant load	1,35				snow2 (2)	0,75
			work+inst1	1,05				work+inst3	1,05
			temperature positive	0,00				temperature positive	0,00
gsn116	uls	Envelope - ultimate	LC1 - Self weight	1,35	gsn124	uls	Envelope - ultimate	LC1 - Self weight	1,35
			snow2 (1)	0,75				wind -0.3	1,50
			wind 0.2	1,50				constant load	1,35
			constant load	1,35				work+inst1	1,05
			work+inst2	1,05				snow2 (2)	0,75
			temperature positive	0,00				temperature positive	0,00
gsn117	uls	Envelope - ultimate	LC1 - Self weight	1,35	gsn125	uls	Envelope - ultimate	LC1 - Self weight	1,35
			snow2 (1)	0,75				wind -0.3	1,50
			wind 0.2	1,50				constant load	1,35
			constant load	1,35				snow2 (2)	0,75
			work+inst3	1,05				work+inst2	1,05
			temperature positive	0,00				temperature positive	0,00
gsn118	uls	Envelope - ultimate	LC1 - Self weight	1,35	gsn126	uls	Envelope - ultimate	LC1 - Self weight	1,35
			snow2 (1)	0,75				wind -0.3	1,50
			wind -0.3	1,50				constant load	1,35
			constant load	1,35				snow2 (2)	0,75
			work+inst1	1,05				work+inst3	1,05
			temperature positive	0,00				temperature positive	0,00
gsn119	uls	Envelope - ultimate	LC1 - Self weight	1,35	gsn127	uls	Envelope - ultimate	LC1 - Self weight	1,35
			snow2 (1)	0,75				snow	1,50
			wind -0.3	1,50				constant load	1,35
			constant load	1,35				work+inst1	1,05
			work+inst2	1,05				temperature positive	0,00
			temperature positive	0,00	gsn128	uls	Envelope - ultimate	LC1 - Self weight	1,35
gsn120	uls	Envelope - ultimate	LC1 - Self weight	1,35				snow	1,50
			snow2 (1)	0,75				constant load	1,35
			wind -0.3	1,50				work+inst2	1,05
			constant load	1,35				temperature positive	0,00
			work+inst3	1,05	gsn129	uls	Envelope - ultimate	LC1 - Self weight	1,35
			temperature positive	0,00				snow	1,50
gsn121	uls	Envelope - ultimate	LC1 - Self weight	1,35				constant load	1,35
			wind 0.2	1,50				work+inst3	1,05
			constant load	1,35				temperature positive	0,00
			work+inst1	1,05	gsn130	uls	Envelope - ultimate	LC1 - Self weight	1,35
			snow2 (2)	0,75				snow2 (1)	1,50
			temperature positive	0,00				constant load	1,35
								work+inst1	1,05
								temperature positive	0,00

gsn131	u b	Envelope - ultimate	LC1 - Self weight	1,35
			snow2 (1)	1,50
			constant load	1,35
			work+inst2	1,05
			temperature positive	0,00
gsn132	u b	Envelope - ultimate	LC1 - Self weight	1,35
			snow2 (1)	1,50
			constant load	1,35
			work+inst3	1,05
			temperature positive	0,00
gsn133	u b	Envelope - ultimate	LC1 - Self weight	1,35
			constant load	1,35
			work+inst1	1,05
			snow2 (2)	1,50
			temperature positive	0,00
gsn134	u b	Envelope - ultimate	LC1 - Self weight	1,35
			constant load	1,35
			snow2 (2)	1,50
			work+inst2	1,05
			temperature positive	0,00
gsn135	u b	Envelope - ultimate	LC1 - Self weight	1,35
			constant load	1,35
			snow2 (2)	1,50
			work+inst3	1,05
			temperature positive	0,00
gsn46 uplift2	u b	Envelope - ultimate	LC1 - Self weight	1,00
			wind -0.3	1,50
			constant load	1,00
			temperature positive	0,00

3.3.2 Serviceability limit states (SLS)

Combinations

Name	Description	Type	Load cases	Coeff. [-]
<i>*Student version*</i>	<i>*Student version*</i>	<i>*Student version*</i>	<i>*Student version*</i>	<i>*Student version*</i>
gsu1	sls	Envelope - serviceability	LC1 - Self weight snow wind 0.2 constant load work+inst1 temperature positive	1,00 1,00 0,60 1,00 0,70 0,60
gsu2	sls	Envelope - serviceability	LC1 - Self weight snow wind -0.3 constant load work+inst1 temperature positive	1,00 1,00 0,60 1,00 0,70 0,60
gsu3	sls	Envelope - serviceability	LC1 - Self weight snow wind 0.2 constant load work+inst2 temperature positive	1,00 1,00 0,60 1,00 0,70 0,60
gsu4	sls	Envelope - serviceability	LC1 - Self weight snow wind -0.3 constant load work+inst2 temperature positive	1,00 1,00 0,60 1,00 0,70 0,60
gsu5	sls	Envelope - serviceability	LC1 - Self weight snow wind 0.2 constant load work+inst3 temperature positive	1,00 1,00 0,60 1,00 0,70 0,60
gsu6	sls	Envelope - serviceability	LC1 - Self weight snow wind -0.3 constant load work+inst3 temperature positive	1,00 1,00 0,60 1,00 0,70 0,60
gsu7	sls	Envelope - serviceability	LC1 - Self weight snow2 (1) wind 0.2 constant load work+inst1 temperature positive	1,00 1,00 0,60 1,00 0,70 0,60
gsu8	sls	Envelope - serviceability	LC1 - Self weight snow2 (1) wind -0.3 constant load work+inst1 temperature positive	1,00 1,00 0,60 1,00 0,70 0,60
gsu9	sls	Linear - serviceability	LC1 - Self weight snow2 (1) wind 0.2 constant load work+inst2 temperature positive	1,00 1,00 0,60 1,00 0,70 0,60
gsu10	sls	Envelope - serviceability	LC1 - Self weight snow2 (1) wind -0.3 constant load work+inst2 temperature positive	1,00 1,00 0,60 1,00 0,70 0,60
gsu11	sls	Envelope - serviceability	LC1 - Self weight snow2 (1) wind 0.2 constant load work+inst3 temperature positive	1,00 1,00 0,60 1,00 0,70 0,60
gsu12	sls	Envelope - serviceability	LC1 - Self weight snow2 (1) wind -0.3 constant load work+inst3 temperature positive	1,00 1,00 0,60 1,00 0,70 0,60
gsu13	sls	Envelope - serviceability	LC1 - Self weight wind 0.2 constant load work+inst1 snow2 (2) temperature positive	1,00 0,60 1,00 0,70 1,00 0,60
gsu14	sls	Envelope - serviceability	LC1 - Self weight wind -0.3 constant load work+inst1 snow2 (2) temperature positive	1,00 0,60 1,00 0,70 1,00 0,60
gsu15	sls	Envelope - serviceability	LC1 - Self weight wind 0.2 constant load snow2 (2) work+inst2 temperature positive	1,00 0,60 1,00 1,00 0,70 0,60

gsu16	sls	Envelope - serviceability	LC1 - Self weight	1,00	gsu24	sls	Envelope - serviceability	LC1 - Self weight	1,00
			wind -0.3	0,60				snow	0,50
			constant load	1,00				wind -0.3	1,00
			snow2 (2)	1,00				constant load	1,00
			work+inst2	0,70				work+inst3	0,70
			temperature positive	0,60				temperature positive	0,60
gsu17	sls	Envelope - serviceability	LC1 - Self weight	1,00	gsu25	sls	Envelope - serviceability	LC1 - Self weight	1,00
			wind 0.2	0,60				snow2 (1)	0,50
			constant load	1,00				wind 0.2	1,00
			snow2 (2)	1,00				constant load	1,00
			work+inst3	0,70				work+inst1	0,70
			temperature positive	0,60				temperature positive	0,60
gsu18	sls	Envelope - serviceability	LC1 - Self weight	1,00	gsu26	sls	Envelope - serviceability	LC1 - Self weight	1,00
			wind -0.3	0,60				snow2 (1)	0,50
			constant load	1,00				wind 0.2	1,00
			snow2 (2)	1,00				constant load	1,00
			work+inst3	0,70				work+inst2	0,70
			temperature positive	0,60				temperature positive	0,60
gsu19	sls	Envelope - serviceability	LC1 - Self weight	1,00	gsu27	sls	Envelope - serviceability	LC1 - Self weight	1,00
			snow	0,50				snow2 (1)	0,50
			wind 0.2	1,00				wind 0.2	1,00
			constant load	1,00				constant load	1,00
			work+inst1	0,70				work+inst3	0,70
			temperature positive	0,60				temperature positive	0,60
gsu20	sls	Envelope - serviceability	LC1 - Self weight	1,00	gsu28	sls	Envelope - serviceability	LC1 - Self weight	1,00
			snow	0,50				snow2 (1)	0,50
			wind 0.2	1,00				wind -0.3	1,00
			constant load	1,00				constant load	1,00
			work+inst2	0,70				work+inst1	0,70
			temperature positive	0,60				temperature positive	0,60
gsu21	sls	Envelope - serviceability	LC1 - Self weight	1,00	gsu29	sls	Envelope - serviceability	LC1 - Self weight	1,00
			snow	0,50				snow2 (1)	0,50
			wind 0.2	1,00				wind -0.3	1,00
			constant load	1,00				constant load	1,00
			work+inst3	0,70				work+inst2	0,70
			temperature positive	0,60				temperature positive	0,60
gsu22	sls	Envelope - serviceability	LC1 - Self weight	1,00	gsu30	sls	Envelope - serviceability	LC1 - Self weight	1,00
			snow	0,50				snow2 (1)	0,50
			wind -0.3	1,00				wind -0.3	1,00
			constant load	1,00				constant load	1,00
			work+inst1	0,70				work+inst3	0,70
			temperature positive	0,60				temperature positive	0,60
gsu23	sls	Envelope - serviceability	LC1 - Self weight	1,00	gsu31	sls	Envelope - serviceability	LC1 - Self weight	1,00
			snow	0,50				wind 0.2	1,00
			wind -0.3	1,00				constant load	1,00
			constant load	1,00				work+inst1	0,70
			work+inst2	0,70				snow2 (2)	0,50
			temperature positive	0,60				temperature positive	0,60

gsu32	sls	Envelbpe - serviceability	LC1 - Self weight	1,00	gsu41	sls	Envelbpe - serviceability	LC1 - Self weight	1,00
			wind 0.2	1,00				snow2 (1)	1,00
			constant load	1,00				constant load	1,00
			snow2 (2)	0,50				work-inst2	0,70
			work-inst2	0,70				temperature positive	0,80
			temperature positive	0,80	gsu42	sls	Envelbpe - serviceability	LC1 - Self weight	1,00
gsu33	sls	Envelbpe - serviceability	LC1 - Self weight	1,00				snow2 (1)	1,00
			wind 0.2	1,00				constant load	1,00
			constant load	1,00				work-inst3	0,70
			snow2 (2)	0,50				temperature positive	0,80
			work-inst3	0,70	gsu43	sls	Envelbpe - serviceability	LC1 - Self weight	1,00
			temperature positive	0,80				constant load	1,00
gsu34	sls	Envelbpe - serviceability	LC1 - Self weight	1,00				work-inst1	0,70
			wind -0.3	1,00				snow2 (2)	1,00
			constant load	1,00				temperature positive	0,80
			work-inst1	0,70	gsu44	sls	Envelbpe - serviceability	LC1 - Self weight	1,00
			snow2 (2)	0,50				constant load	1,00
			temperature positive	0,80				snow2 (2)	1,00
gsu35	sls	Envelbpe - serviceability	LC1 - Self weight	1,00				work-inst2	0,70
			wind -0.3	1,00				temperature positive	0,80
			constant load	1,00	gsu45	sls	Envelbpe - serviceability	LC1 - Self weight	1,00
			snow2 (2)	0,50				constant load	1,00
			work-inst2	0,70				snow2 (2)	1,00
			temperature positive	0,80				work-inst2	0,70
gsu36	sls	Envelbpe - serviceability	LC1 - Self weight	1,00				temperature positive	0,80
			wind -0.3	1,00	gsu46	sls	Envelbpe - serviceability	LC1 - Self weight	1,00
			constant load	1,00				constant load	1,00
			snow2 (2)	0,50				snow2 (2)	1,00
			work-inst3	0,70				work-inst3	0,70
			temperature positive	0,80	gsu46 uplift	sls	Envelbpe - serviceability	LC1 - Self weight	1,00
gsu37	sls	Envelbpe - serviceability	LC1 - Self weight	1,00				wind -0.3	1,00
			snow	1,00				constant load	1,00
			constant load	1,00				temperature positive	0,80
			work-inst1	0,70	gsu46	sls	Envelbpe - serviceability	LC1 - Self weight	1,00
			temperature positive	0,80				snow	1,00
gsu38	sls	Envelbpe - serviceability	LC1 - Self weight	1,00				wind 0.2	0,80
			snow	1,00				constant load	1,00
			constant load	1,00				work-inst1	0,70
			work-inst2	0,70				temperature negative	0,80
			temperature positive	0,80	gsu47	sls	Envelbpe - serviceability	LC1 - Self weight	1,00
gsu39	sls	Envelbpe - serviceability	LC1 - Self weight	1,00				snow	1,00
			snow	1,00				wind -0.3	0,80
			constant load	1,00				constant load	1,00
			work-inst3	0,70				work-inst1	0,70
			temperature positive	0,80				temperature negative	0,80
gsu40	sls	Envelbpe - serviceability	LC1 - Self weight	1,00	gsu48	sls	Envelbpe - serviceability	LC1 - Self weight	1,00
			snow2 (1)	1,00				snow	1,00
			constant load	1,00				wind 0.2	0,80
			work-inst1	0,70				constant load	1,00
			temperature positive	0,80				work-inst2	0,70
								temperature negative	0,80

gsu49	sls	Envelope - serviceability	LC1 - Self weight snow wind -0.3 constant load work+inst2 temperature negative	1,00 1,00 0,80 1,00 0,70 0,80	gsu57	sls	Envelope - serviceability	LC1 - Self weight snow2 (1) wind -0.3 constant load work+inst3 temperature negative	1,00 1,00 0,80 1,00 0,70 0,80
gsu50	sls	Envelope - serviceability	LC1 - Self weight snow wind 0.2 constant load work+inst3 temperature negative	1,00 1,00 0,80 1,00 0,70 0,80	gsu58	sls	Envelope - serviceability	LC1 - Self weight wind 0.2 constant load work+inst1 snow2 (2) temperature negative	1,00 0,80 1,00 0,70 1,00 0,80
gsu51	sls	Envelope - serviceability	LC1 - Self weight snow wind -0.3 constant load work+inst3 temperature negative	1,00 1,00 0,80 1,00 0,70 0,80	gsu59	sls	Envelope - serviceability	LC1 - Self weight wind -0.3 constant load work+inst1 snow2 (2) temperature negative	1,00 0,80 1,00 0,70 1,00 0,80
gsu52	sls	Envelope - serviceability	LC1 - Self weight snow2 (1) wind 0.2 constant load work+inst1 temperature negative	1,00 1,00 0,80 1,00 0,70 0,80	gsu60	sls	Envelope - serviceability	LC1 - Self weight wind 0.2 constant load snow2 (2) work+inst2 temperature negative	1,00 0,80 1,00 1,00 0,70 0,80
gsu53	sls	Envelope - serviceability	LC1 - Self weight snow2 (1) wind -0.3 constant load work+inst1 temperature negative	1,00 1,00 0,80 1,00 0,70 0,80	gsu61	sls	Envelope - serviceability	LC1 - Self weight wind -0.3 constant load snow2 (2) work+inst2 temperature negative	1,00 0,80 1,00 1,00 0,70 0,80
gsu54	sls	Linear - serviceability	LC1 - Self weight snow2 (1) wind 0.2 constant load work+inst2 temperature negative	1,00 1,00 0,80 1,00 0,70 0,80	gsu62	sls	Envelope - serviceability	LC1 - Self weight wind 0.2 constant load snow2 (2) work+inst3 temperature negative	1,00 0,80 1,00 1,00 0,70 0,80
gsu55	sls	Envelope - serviceability	LC1 - Self weight snow2 (1) wind -0.3 constant load work+inst2 temperature negative	1,00 1,00 0,80 1,00 0,70 0,80	gsu63	sls	Envelope - serviceability	LC1 - Self weight wind -0.3 constant load snow2 (2) work+inst3 temperature negative	1,00 0,80 1,00 1,00 0,70 0,80
gsu56	sls	Envelope - serviceability	LC1 - Self weight snow2 (1) wind 0.2 constant load work+inst3 temperature negative	1,00 1,00 0,80 1,00 0,70 0,80	gsu64	sls	Envelope - serviceability	LC1 - Self weight snow wind 0.2 constant load work+inst1 temperature negative	1,00 0,50 1,00 1,00 0,70 0,80

gsu65	sls	Envelope - serviceability	LC1 - Self weight	1,00	gsu73	sls	Envelope - serviceability	LC1 - Self weight	1,00
			snow	0,50				snow2 (1)	0,50
			wind 0.2	1,00				wind -0.3	1,00
			constant load	1,00				constant load	1,00
			work+inst2	0,70				work+inst1	0,70
			temperature negative	0,60				temperature negative	0,60
gsu66	sls	Envelope - serviceability	LC1 - Self weight	1,00	gsu74	sls	Envelope - serviceability	LC1 - Self weight	1,00
			snow	0,50				snow2 (1)	0,50
			wind 0.2	1,00				wind -0.3	1,00
			constant load	1,00				constant load	1,00
			work+inst3	0,70				work+inst2	0,70
			temperature negative	0,60				temperature negative	0,60
gsu67	sls	Envelope - serviceability	LC1 - Self weight	1,00	gsu75	sls	Envelope - serviceability	LC1 - Self weight	1,00
			snow	0,50				snow2 (1)	0,50
			wind -0.3	1,00				wind -0.3	1,00
			constant load	1,00				constant load	1,00
			work+inst1	0,70				work+inst3	0,70
			temperature negative	0,60				temperature negative	0,60
gsu68	sls	Envelope - serviceability	LC1 - Self weight	1,00	gsu76	sls	Envelope - serviceability	LC1 - Self weight	1,00
			snow	0,50				wind 0.2	1,00
			wind -0.3	1,00				constant load	1,00
			constant load	1,00				work+inst1	0,70
			work+inst2	0,70				snow2 (2)	0,50
			temperature negative	0,60				temperature negative	0,60
gsu69	sls	Envelope - serviceability	LC1 - Self weight	1,00	gsu77	sls	Envelope - serviceability	LC1 - Self weight	1,00
			snow	0,50				wind 0.2	1,00
			wind -0.3	1,00				constant load	1,00
			constant load	1,00				snow2 (2)	0,50
			work+inst3	0,70				work+inst2	0,70
			temperature negative	0,60				temperature negative	0,60
gsu70	sls	Envelope - serviceability	LC1 - Self weight	1,00	gsu78	sls	Envelope - serviceability	LC1 - Self weight	1,00
			snow2 (1)	0,50				wind 0.2	1,00
			wind 0.2	1,00				constant load	1,00
			constant load	1,00				snow2 (2)	0,50
			work+inst1	0,70				work+inst3	0,70
			temperature negative	0,60				temperature negative	0,60
gsu71	sls	Envelope - serviceability	LC1 - Self weight	1,00	gsu79	sls	Envelope - serviceability	LC1 - Self weight	1,00
			snow2 (1)	0,50				wind -0.3	1,00
			wind 0.2	1,00				constant load	1,00
			constant load	1,00				work+inst1	0,70
			work+inst2	0,70				snow2 (2)	0,50
			temperature negative	0,60				temperature negative	0,60
gsu72	sls	Envelope - serviceability	LC1 - Self weight	1,00	gsu80	sls	Envelope - serviceability	LC1 - Self weight	1,00
			snow2 (1)	0,50				wind -0.3	1,00
			wind 0.2	1,00				constant load	1,00
			constant load	1,00				snow2 (2)	0,50
			work+inst3	0,70				work+inst2	0,70
			temperature negative	0,60				temperature negative	0,60

gau81	sls	Envelope - serviceability	LC1 - Self weight	1,00
			wind -0.3	1,00
			constant load	1,00
			snow2 (2)	0,60
			work+inst3	0,70
			temperature negative	0,60
gau82	sls	Envelope - serviceability	LC1 - Self weight	1,00
			snow	1,00
			constant load	1,00
			work+inst1	0,70
			temperature negative	0,60
gau83	sls	Envelope - serviceability	LC1 - Self weight	1,00
			snow	1,00
			constant load	1,00
			work+inst2	0,70
			temperature negative	0,60
gau84	sls	Envelope - serviceability	LC1 - Self weight	1,00
			snow	1,00
			constant load	1,00
			work+inst3	0,70
			temperature negative	0,60
gau85	sls	Envelope - serviceability	LC1 - Self weight	1,00
			snow2 (1)	1,00
			constant load	1,00
			work+inst1	0,70
			temperature negative	0,60
gau86	sls	Envelope - serviceability	LC1 - Self weight	1,00
			snow2 (1)	1,00
			constant load	1,00
			work+inst2	0,70
			temperature negative	0,60
gau87	sls	Envelope - serviceability	LC1 - Self weight	1,00
			snow2 (1)	1,00
			constant load	1,00
			work+inst3	0,70
			temperature negative	0,60
gau88	sls	Envelope - serviceability	LC1 - Self weight	1,00
			constant load	1,00
			work+inst1	0,70
			snow2 (2)	1,00
			temperature negative	0,60

gau89	sls	Envelope - serviceability	LC1 - Self weight	1,00
			constant load	1,00
			snow2 (2)	1,00
			work+inst2	0,70
			temperature negative	0,60
gau90	sls	Envelope - serviceability	LC1 - Self weight	1,00
			constant load	1,00
			snow2 (2)	1,00
			work+inst3	0,70
			temperature negative	0,60
gau46 uplift	sls	Envelope - serviceability	LC1 - Self weight	1,00
			wind -0.3	1,00
			constant load	1,00
			temperature negative	0,60

4. Calculation results

4.1. Deformations of construction

4.1.1. Vertical displacement (roof displacement)

Maximum vertical displacement for roof is from combination ULS4

gsn4	uls	Envelope - ultimate	LC1 - Self weight	1,35
			snow	1,50
			wind -0.3	0,90
			constant load	1,35
			work+inst2	1,05
			temperature positive	0,90

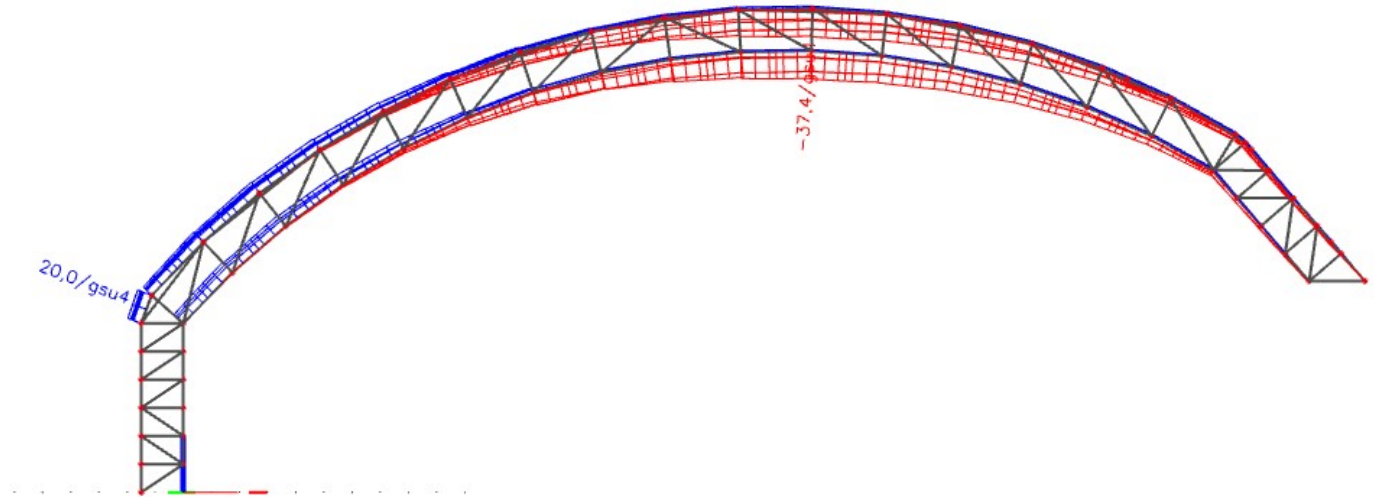

Figure 4.1. Vertical displacement u_z

Vertical displacement: $u_z=37,4$ mm

$$u_{max} = \frac{l}{250} = \frac{40000}{250} = 160,0 \text{ mm} > 37,4 \text{ mm}$$

4.1.2. Horizontal displacement (column displacement)

Maximum horizontal displacement for column is from combination SLS13

gsu13	sls	Envelope - serviceability	LC1 - Self weight	1,00
			wind 0.2	0,60
			constant load	1,00
			work+inst1	0,70
			snow2 (2)	1,00
			temperature positive	0,60

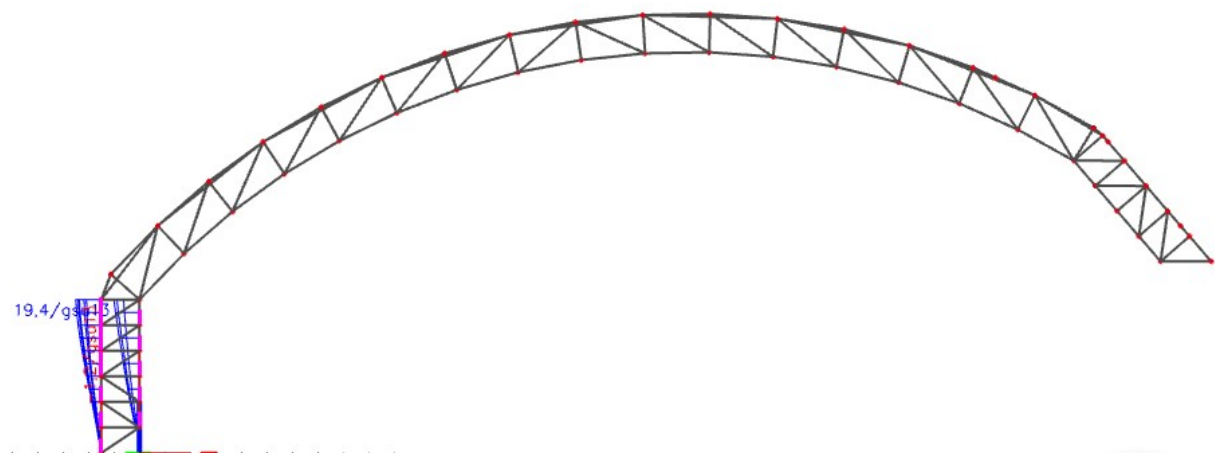

Figure 4.2. Horizontal displacement u_x

Horizontal displacement: $u_x=19,4\text{mm}$

$$u_{max} = \frac{l}{300} = \frac{6000}{300} = 20,0 \text{ mm} > 19,4 \text{ mm}$$

4.1.3. Front sheathing rail deflection

Maximum deflection for front sheathing rail is from combination ULS46

gsu46	sls	Envelope - serviceability	LC1 - Self weight	1,00
			snow	1,00
			wind 0.2	0,60
			constant load	1,00
			work+inst1	0,70
			temperature negative	0,60

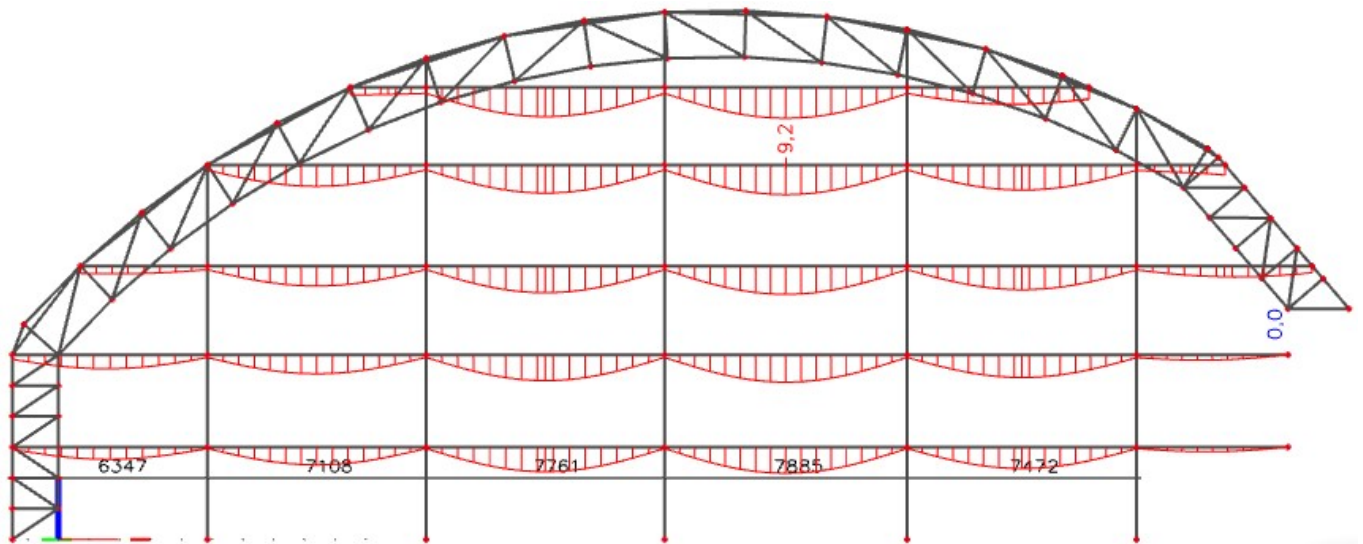

Figure 4.3. Front sheathing rail deflection

Front sheathing rail deflection: $u_x=9,2 \text{ mm}$

$$u_{max} = \frac{l}{300} = \frac{7885}{300} = 26,28 \text{ mm} > 9,2 \text{ mm}$$

4.1.4. Gable column deflection

Maximum deflection of all gable columns is from combination ULS46 uplift

gsu46 uplift	sls	Envelope - serviceability	LC1 - Self weight	1,00
			wind -0.3	1,00
			constant load	1,00
			temperature positive	0,60

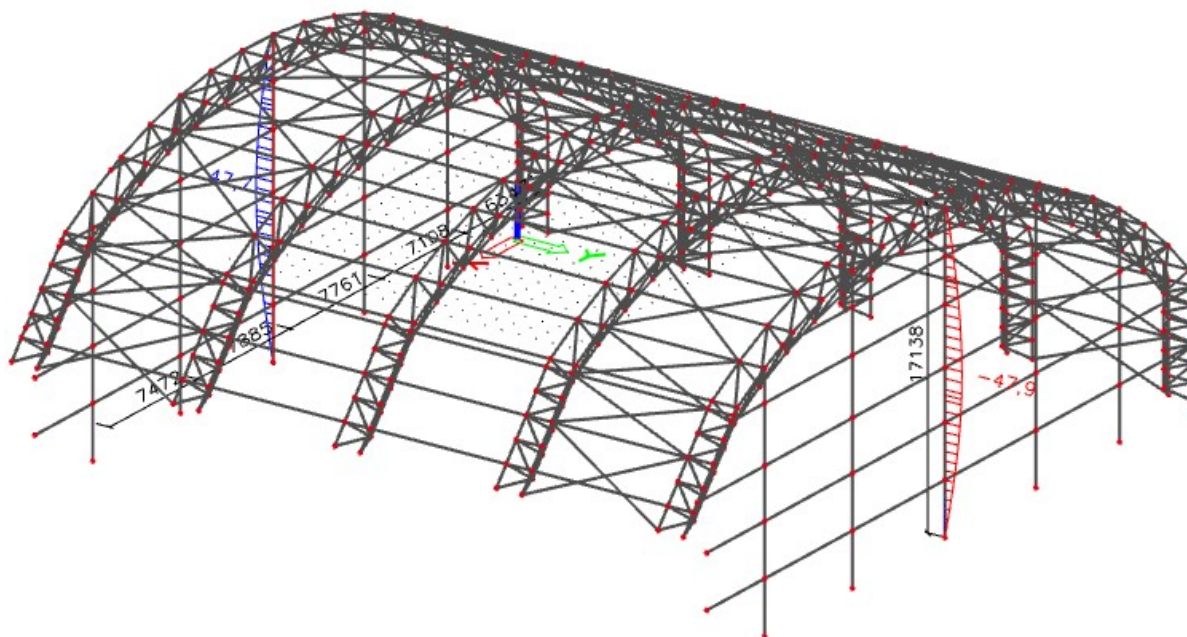

Figure 4.4. Gable column (HEA500) deflection

Gable column (HEA500) deflection: $u_z=47,9$ mm

$$u_{max} = \frac{l}{300} = \frac{17138}{300} = 57,13 \text{ mm} > 47,9 \text{ mm}$$

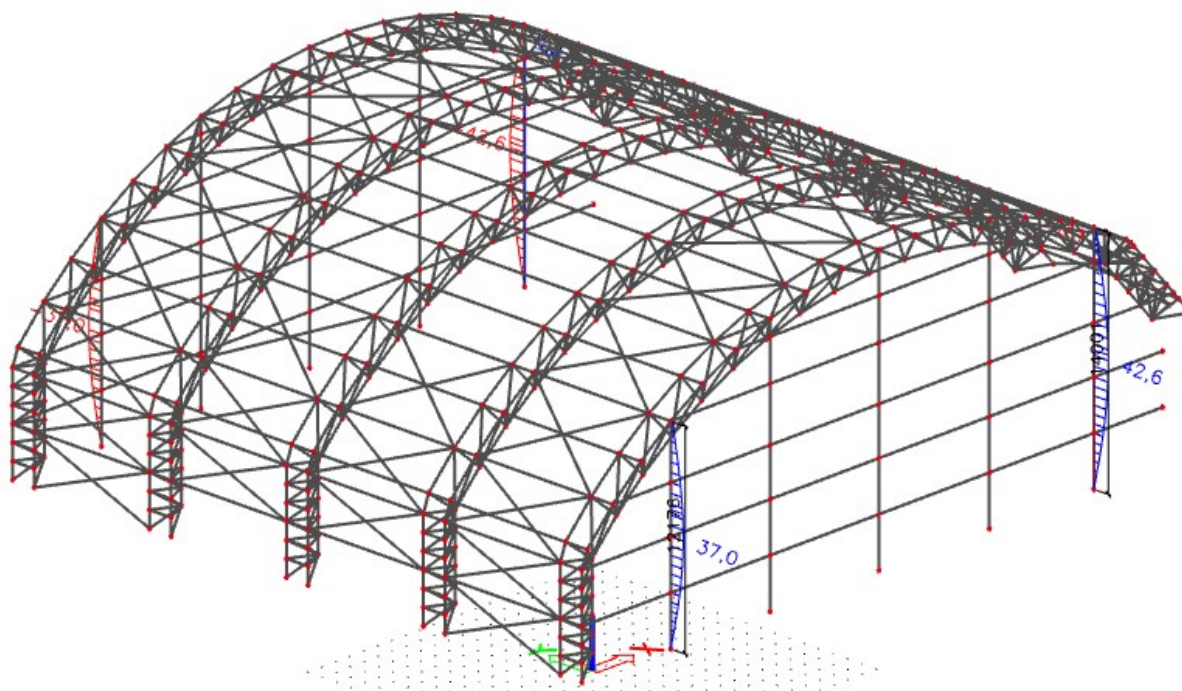

Figure 4.5. Gable column (HEA340) deflection

Member 1: Gable column (HEA340) deflection: $u_z=42,6$ mm

$$u_{max} = \frac{l}{300} = \frac{14000}{300} = 46,67 \text{ mm} > 42,6 \text{ mm}$$

Member 2: Gable column (HEA340) deflection: $u_z=37,0$ mm

$$u_{max} = \frac{l}{300} = \frac{12180}{300} = 40,6 \text{ mm} > 37,0 \text{ mm}$$

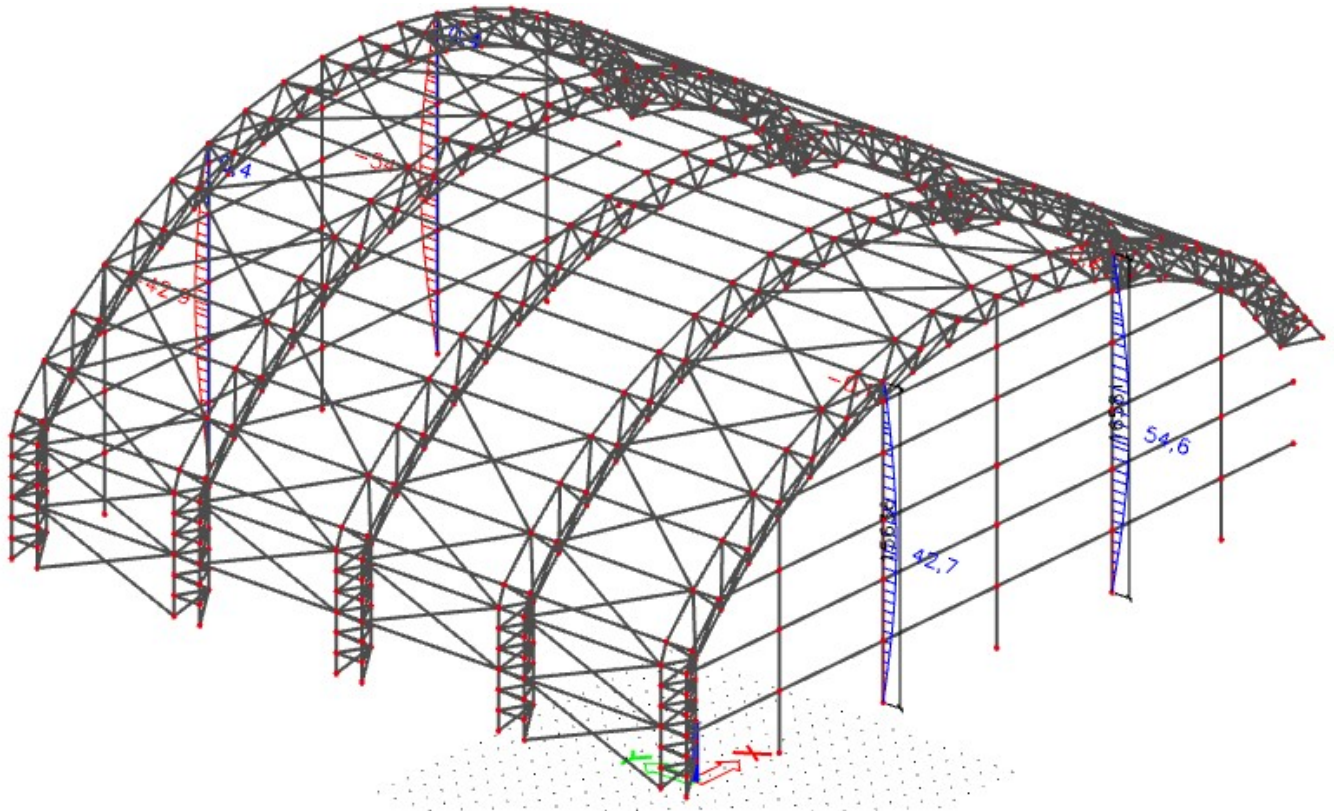

Figure 4.6. Gable column (HEA450) deflection

Member 1: Gable column (HEA450) deflection: $u_z=54,6$ mm

$$u_{max} = \frac{l}{300} = \frac{16581}{300} = 55,27 \text{ mm} > 54,6 \text{ mm}$$

Member 2: Gable column (HEA450) deflection: $u_z=42,7$ mm

$$u_{max} = \frac{l}{300} = \frac{15636}{300} = 52,12 \text{ mm} > 42,7 \text{ mm}$$

4.1.5. Sheating rail deflection

Maximum deflection of a sheating rail is from combination ULS25

gsu25	sls	Envelope - serviceability	LC1 - Self weight	1,00
			snow2 (1)	0,50
			wind 0.2	1,00
			constant load	1,00
			work+inst1	0,70
			temperature positive	0,60

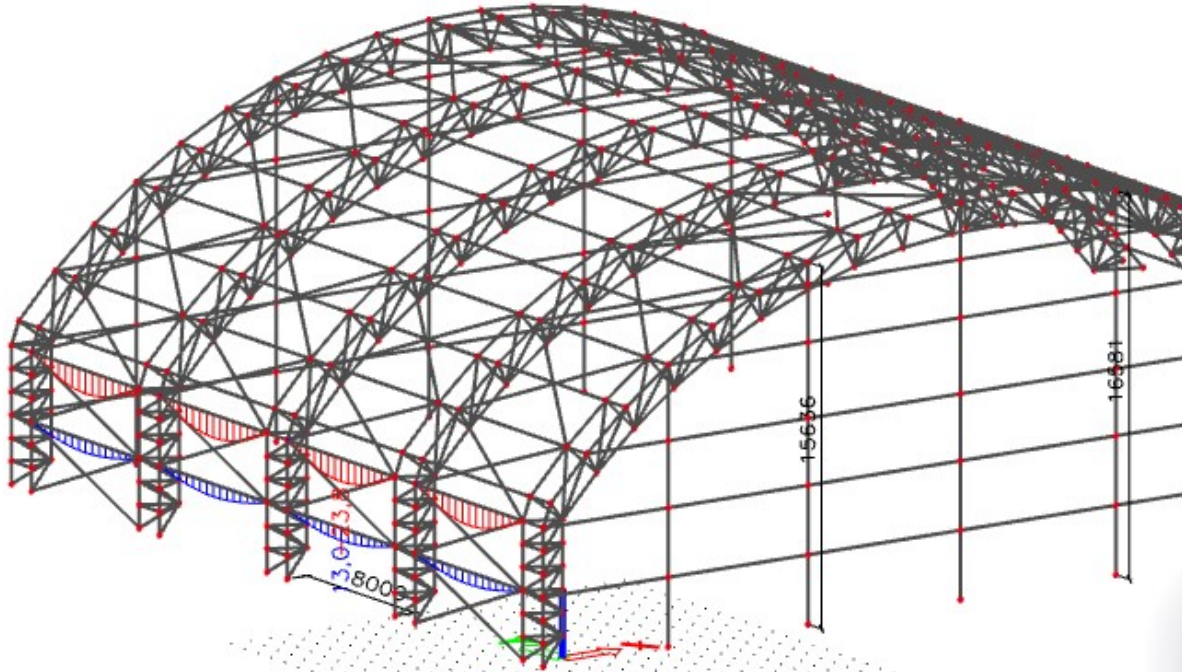

Figure 4.7. Sheathing rail deflection

Sheathing rail deflection: $u_z=23,8$ mm

$$u_{max} = \frac{l}{300} = \frac{8000}{300} = 26,67 \text{ mm} > 23,8 \text{ mm}$$

4.1.6. Purlins deflection

- Maximum deflection of purlin (IPE360) is from combination ULS38

gsu38	sls	Envelope - serviceability	LC1 - Self weight	1,00
			snow	1,00
			constant load	1,00
			work+inst2	0,70
			temperature positive	0,60

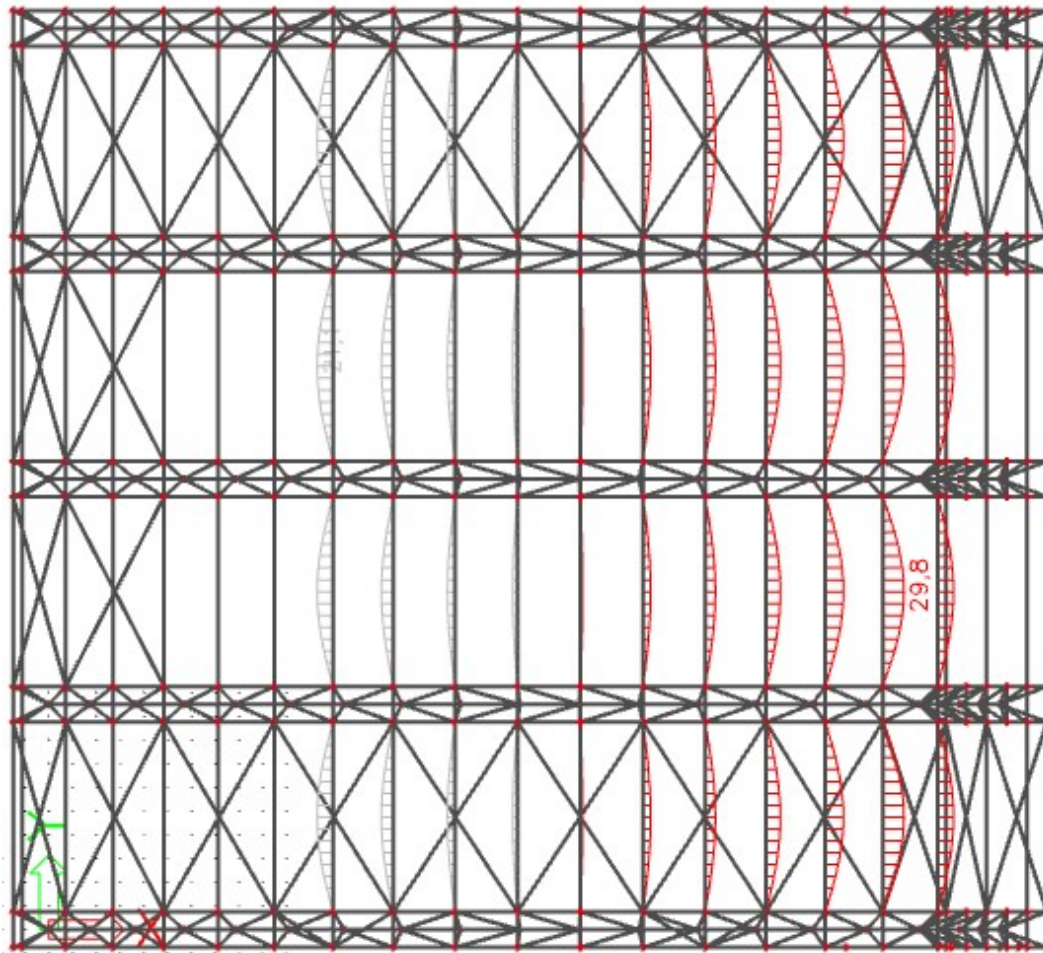

Figure 4.8. Purlin (IPE360) deflection

Purlin (IPE360) deflection: $u_y=29,8$ mm

$$u_{max} = \frac{l}{300} = \frac{8000}{250} = 32,0 \text{ mm} > 29,8 \text{ mm}$$

- Maximum deflection of purlin (HEA220) is from combination ULS38

gsu38	sls	Envelope - serviceability	LC1 - Self weight	1,00
			snow	1,00
			constant load	1,00
			work+inst2	0,70
			temperature positive	0,60

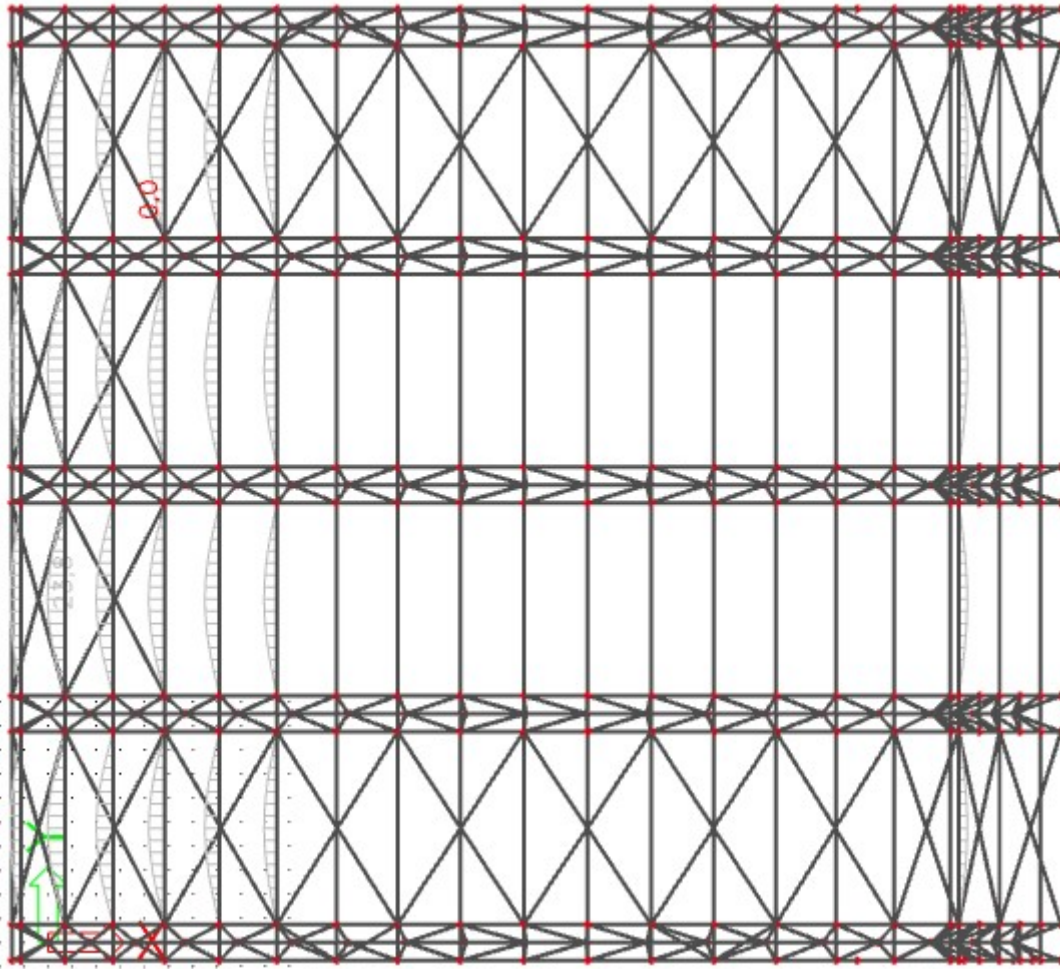

Figure 4.9. Purlin (HEA220) deflection

Purlin (HEA220) deflection: $u_y=23,8$ mm

$$u_{max} = \frac{l}{300} = \frac{8000}{250} = 32,0 \text{ mm} > 23,8 \text{ mm}$$

- Maximum deflection of purlin (HEA280) is from combination ULS45

gsu45	sls	Envelope - serviceability	LC1 - Self weight	1,00
			constant load	1,00
			snow2 (2)	1,00
			work+inst3	0,70
			temperature positive	0,60

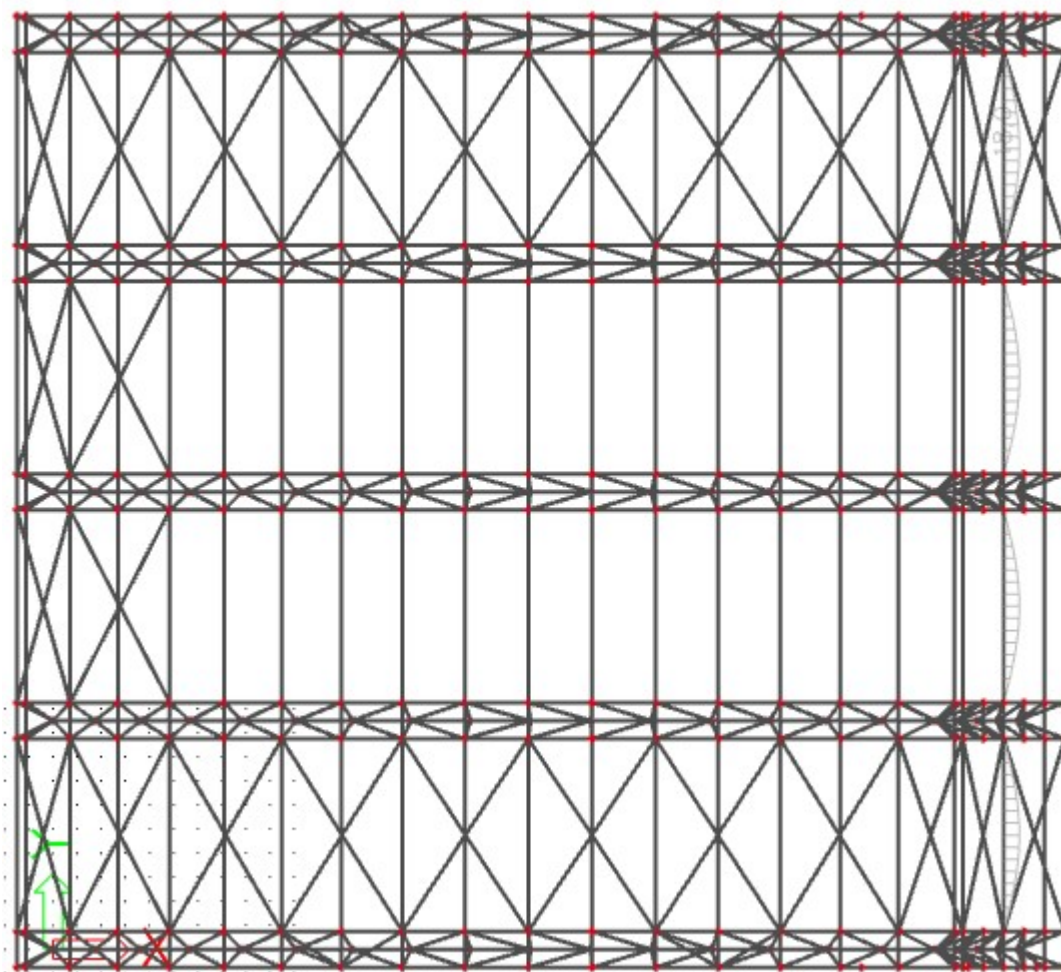

Figure 4.10. Purlin (HEA280) deflection

Purlin (HEA280) deflection: $u_y=18,0$ mm

$$u_{max} = \frac{l}{300} = \frac{8000}{250} = 32,0 \text{ mm} > 18,0 \text{ mm}$$

- Maximum deflection of purlin (HEA300) is from combination ULS18

gsu18	sls	Envelope - serviceability	LC1 - Self weight	1,00
			wind -0.3	0,60
			constant load	1,00
			snow2 (2)	1,00
			work+inst3	0,70
			temperature positive	0,60

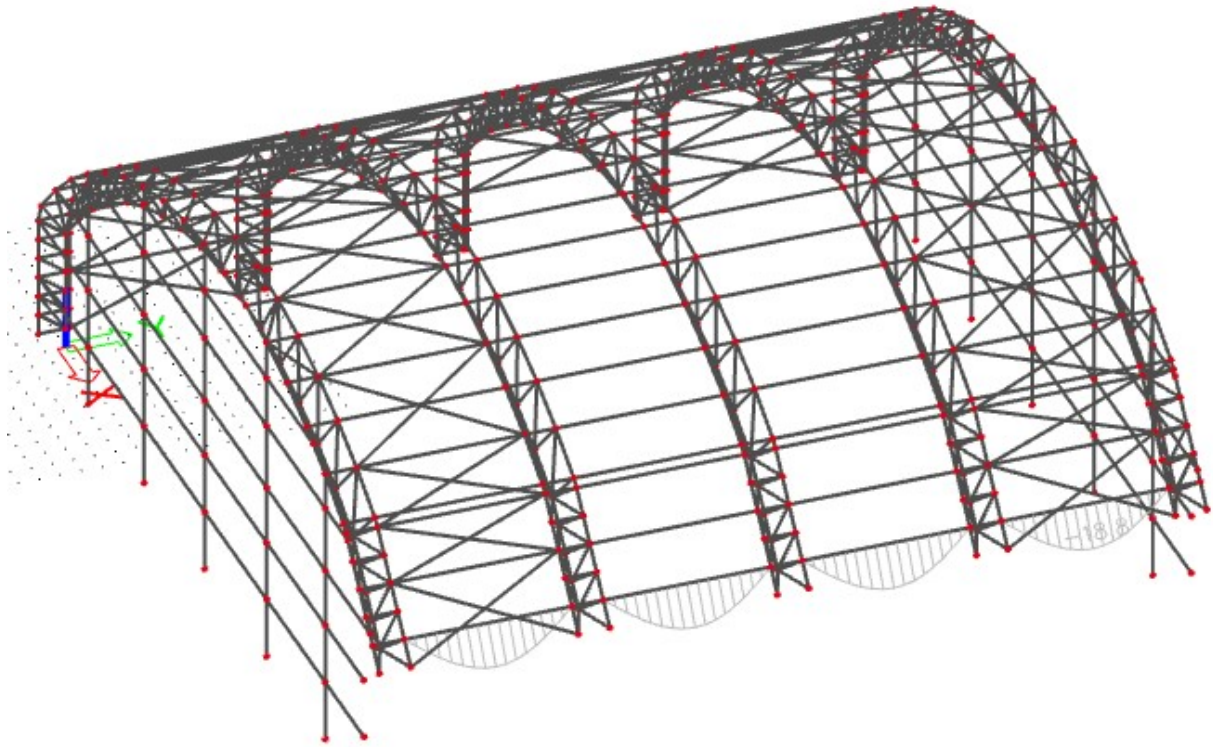

Figure 4.11. Purlin (HEA300) deflection

Purlin (HEA300) deflection: $u_y=18,8$ mm

$$u_{max} = \frac{l}{300} = \frac{8000}{250} = 32,0 \text{ mm} > 18,8 \text{ mm}$$

5. Construction calculation

5.1 Gable column (HEA500)

My

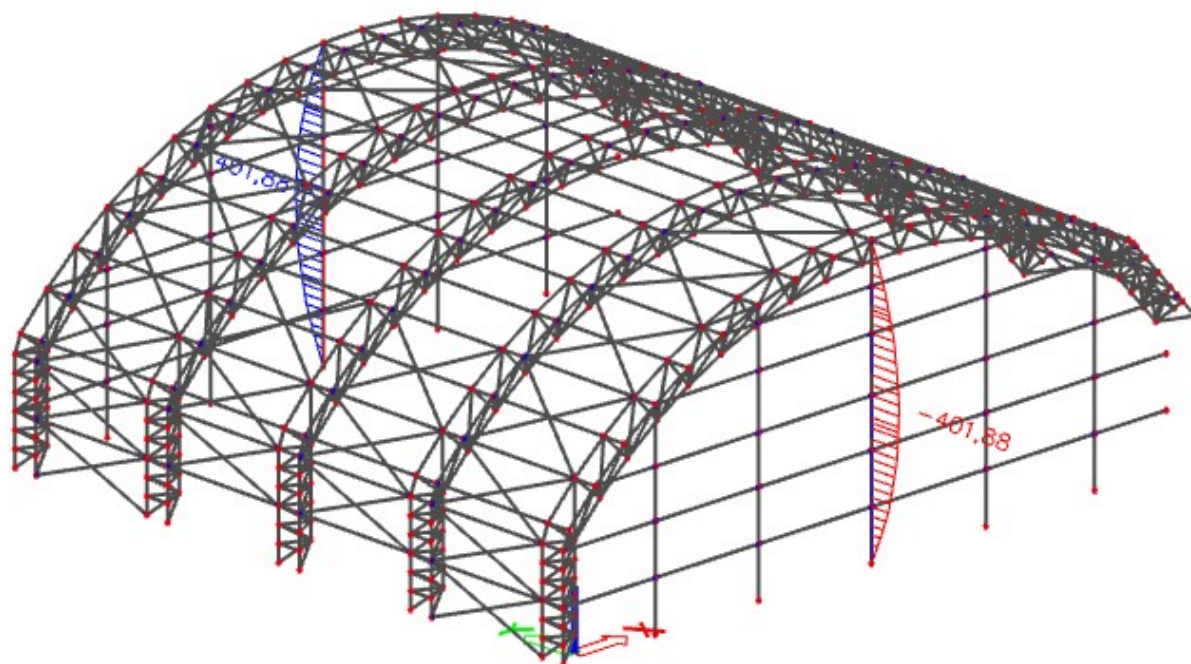

Figure 5.1. Bending moment diagram (My)

Mz

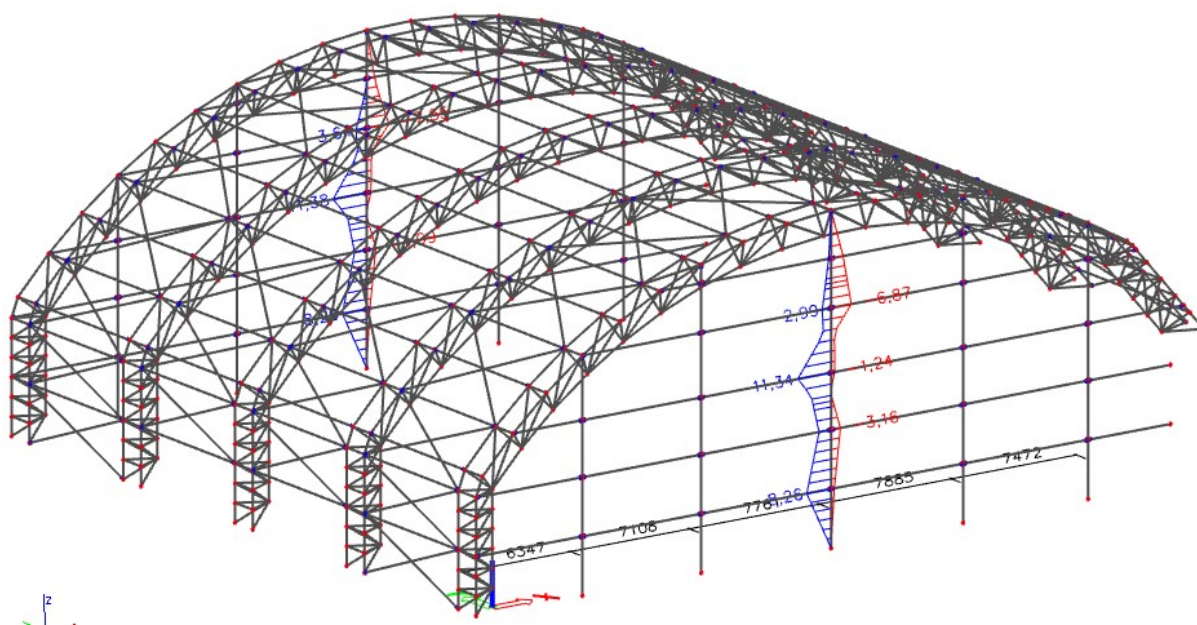

Figure 5.2. Bending moment diagram (Mz)

Relevant combination: ULS28

$g_{sn28} / 1.35 \cdot LC1 + 0.75 \cdot snow2 (1) + 1.50 \cdot wind -0.3 +$
 $1.35 \cdot constant\ load + 1.05 \cdot work+inst1 + 0.90 \cdot temperature$
positive

End

$N = -105,08 \text{ kN}$ (compression)

$M_y = 0 \text{ kNm}$

$V_z = 89,99 \text{ kN}$

$M_z = 0 \text{ kNm}$

$V_y = 2,75 \text{ kN}$

middle

$N = -78,02 \text{ kN}$ (compression)

$M_y = 401,88 \text{ kNm}$

$V_z = 18,85 \text{ kN}$

$M_z = 11,34 \text{ kNm}$

$V_y = 4,70 \text{ kN}$

- Classification of gable column (HEA500)

- Outstand flanges

$$\frac{c}{t} \leq 9 \cdot \varepsilon = 9 \cdot 0,92$$

$$c = \frac{b - t_w - 2 \cdot r}{2} = \frac{300 - 12 - 2 \cdot 27}{2} = 117 \text{ mm}$$

$$\frac{117}{23} = 5,09 \leq 8,28 \Rightarrow \text{class 1}$$

- Internal compression parts

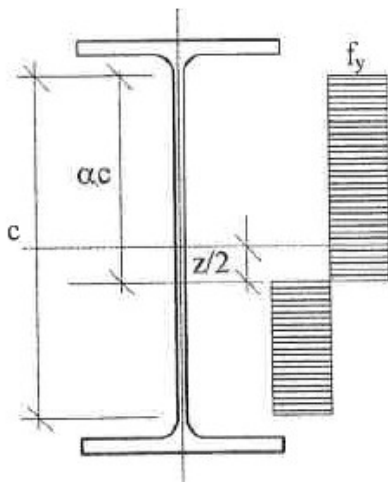

$$z = \frac{N_{Ed}}{t_w \cdot f_{yd}} = \frac{105,08 \cdot 10^3}{12 \cdot 275} = 31,84 \text{ mm}$$

$$\alpha_c = \frac{c + z}{2} = \frac{390 + 31,84}{2} = 179,08 \text{ mm}$$

$$\alpha = \frac{\alpha_c}{c} = \frac{179,08}{390} = 0,46$$

$$\frac{c}{t_w} = \frac{390}{12} = 32,5 < \frac{396 \cdot \varepsilon}{13 \cdot \alpha - 1} = \frac{396 \cdot 0,92}{13 \cdot 0,46 - 1} = 73,16$$

Cross section is in Class 2

1) Compression check

$$\frac{N_{Ed}}{N_{c,Rd}} \leq 1,0$$

$$N_{c,Rd} = \frac{A \cdot f_y}{\gamma_{M0}} = \frac{19750 \cdot 10^{-6} \cdot 275 \cdot 10^3}{1,0} = 5431,25 \text{ kN}$$

$$\frac{105,08}{5431,25} = 0,02 < 1,0$$

2) Shear check for Vz

$$\frac{V_{Ed}}{V_{c,Rd}} \leq 1,0$$

$$V_{c,Rd} = V_{pl,Rd} = \frac{A_v \cdot f_y}{\gamma_{M0} \cdot \sqrt{3}}$$

⇒ A_v for rolled I and H section is:

$$A_v = A - 2 \cdot b \cdot t_f + (t_w + 2 \cdot r) \cdot t_f = 19750 - 2 \cdot 300 \cdot 23 + (12 + 2 \cdot 27) \cdot 23 = 7468 \text{ mm}^2$$

$$V_{pl,Rd} = \frac{4768 \cdot 10^{-6} \cdot 275 \cdot 10^3}{1,0 \cdot \sqrt{3}} = 757,02 \text{ kN}$$

$$\frac{89,99}{757,02} = 0,12 < 1,0$$

3) Uniform members in bending and axial compression

$$\frac{N_{Ed}}{\chi_y \cdot N_{Rk}} + k_{yy} \cdot \frac{M_{y,Ed}}{\chi_{LT} \cdot \frac{M_{y,Rk}}{\gamma_{M1}}} + k_{yz} \cdot \frac{M_{z,Ed}}{\frac{M_{z,Rk}}{\gamma_{M1}}} \leq 1,0 \quad (1)$$

$$\frac{N_{Ed}}{\chi_z \cdot N_{Rk}} + k_{zy} \cdot \frac{M_{y,Ed}}{\chi_{LT} \cdot \frac{M_{y,Rk}}{\gamma_{M1}}} + k_{zz} \cdot \frac{M_{z,Ed}}{\frac{M_{z,Rk}}{\gamma_{M1}}} \leq 1,0 \quad (2)$$

$$\lambda_{rel,0} = \sqrt{\frac{A \cdot f_y}{N_{cr}}} = \frac{L_{cr}}{i} \cdot \frac{1}{\lambda_1}$$

$$\lambda_1 = 93,9 \cdot \varepsilon = 93,9 \cdot 0,92 = 86,39$$

$$N_{Rk} = f_y \cdot A_i = 275 \cdot 10^3 \cdot 19750 \cdot 10^{-6} = 5431,25 \text{ kN}$$

$$M_{y,Rk} = f_y \cdot W_{pl,y} = 275 \cdot 10^3 \cdot 3949 \cdot 10^3 \cdot 10^{-9} = 1085,98 \text{ kNm}$$

$$M_{z,Rk} = f_y \cdot W_{pl,z} = 275 \cdot 10^3 \cdot 1059 \cdot 10^3 \cdot 10^{-9} = 291,23 \text{ kNm}$$

Y	Z
$\lambda_{rel,0,y} = \frac{L_{cr,y}}{i_y} \cdot \frac{1}{\lambda_1} = \frac{17138}{210} \cdot \frac{1}{86,39}$	$\lambda_{rel,0,z} = \frac{L_{cr,z}}{i_z} \cdot \frac{1}{\lambda_1} = \frac{3283}{72,4} \cdot \frac{1}{86,39}$
$\lambda_{rel,0,y} = 0,94$	$\lambda_{rel,0,z} = 0,52$
$\chi_y = \frac{1}{\Phi_y + \sqrt{\Phi_y^2 - \lambda_{rel,0,y}^2}}$	$\chi_z = \frac{1}{\Phi_z + \sqrt{\Phi_z^2 - \lambda_{rel,0,z}^2}}$
$\Phi_y = 0,5(1 + \alpha(\lambda_{rel,0,y} - 0,2) + \lambda_{rel,0,y}^2)$	$\Phi_z = 0,5(1 + \alpha(\lambda_{rel,0,z} - 0,2) + \lambda_{rel,0,z}^2)$
Buckling curve	Buckling curve
y-y => a → $\alpha = 0,21$	z-z => b → $\alpha = 0,34$
$\Phi_y = 0,5(1 + 0,21(0,94 - 0,2) + 0,94^2)$	$\Phi_z = 0,5(1 + 0,34(0,52 - 0,2) + 0,52^2)$
	$\Phi_z = 0,690$

$\Phi_y = 1,02$ $\chi_y = \frac{1}{1,02 + \sqrt{1,02^2 - 0,94^2}}$ $\chi_y = 0,71$	$\chi_z = \frac{1}{\Phi_z + \sqrt{\Phi_z^2 - \lambda_{rel,0,z}^2}}$ $\chi_z = 0,87$
--	---

$$\lambda_{rel,0,LT} = \sqrt{\frac{W_y \cdot f_y}{M_{cr}}} \rightarrow W_y = W_{pl,y} \rightarrow \text{for class 2}$$

$$\chi_{LT} = \frac{1}{\Phi_{LT} + \sqrt{\Phi_{LT}^2 - \lambda_{rel,0,LT}^2}}$$

$$\Phi_{LT} = 0,5(1 + \alpha(\lambda_{rel,0,LT} - 0,2) + \lambda_{rel,0,LT}^2)$$

→ buckling curve **a** => $\alpha_{LT} = 0,21$

$$M_{cr} = \mu_{cr} \cdot \frac{\pi \cdot \sqrt{E \cdot I_z \cdot G \cdot I_t}}{L}$$

$$\mu_{cr} = \frac{C_1}{k_z} \cdot \left(\sqrt{1 + \kappa_{wt}^2 + (C_2 \cdot \zeta_g - C_3 \cdot \zeta_j)^2} - (C_2 \cdot \zeta_g - C_3 \cdot \zeta_j) \right)$$

From table 456

$$k_y = 1,0$$

$$k_z = 1,0 \rightarrow \text{no restrain}$$

$$k_w = 1,0 \rightarrow \text{should be taken because there are no special provision for warping restrain}$$

$$C_1 = 1,13 \quad \zeta_g = 0$$

$$C_2 = 0,46 \quad \zeta_j = 0$$

$$C_3 = 0,53$$

$$\kappa_{wt} = \frac{\pi}{k_w \cdot L} \cdot \sqrt{\frac{E \cdot I_w}{G \cdot I_t}} = \frac{\pi}{1,0 \cdot 17138} \cdot \sqrt{\frac{210000 \cdot 5643000 \cdot 10^6}{80700 \cdot 309,3 \cdot 10^4}}$$

$$\kappa_{wt} = 0,4$$

$$\mu_{cr} = \frac{1,13}{1,0} \cdot (\sqrt{1 + 0,4^2}) = 1,22$$

$$M_{cr} = 1,22 \cdot \frac{\pi \cdot \sqrt{210000 \cdot 10^3 \cdot 10370 \cdot 10^4 \cdot 10^{-12} \cdot 80700 \cdot 10^3 \cdot 309,3 \cdot 10^4 \cdot 10^{-12}}}{17138}$$

$$M_{cr} = 521,41 \text{ kNm}$$

$$\lambda_{rel,0,LT} = \sqrt{\frac{W_{pl,y} \cdot f_y}{M_{cr}}} = \sqrt{\frac{3949 \cdot 10^3 \cdot 10^{-9} \cdot 275 \cdot 10^3}{521,41}}$$

$$\lambda_{rel,0,LT} = 1,44$$

$$\Phi_{LT} = 0,5(1 + 0,21(1,44 - 0,2) + 1,44^2)$$

$$\Phi_{LT} = 1,67$$

$$\chi_{LT} = \frac{1}{1,67 + \sqrt{1,67^2 - 1,44^2}}$$

$$\chi_{LT} = 0,4$$

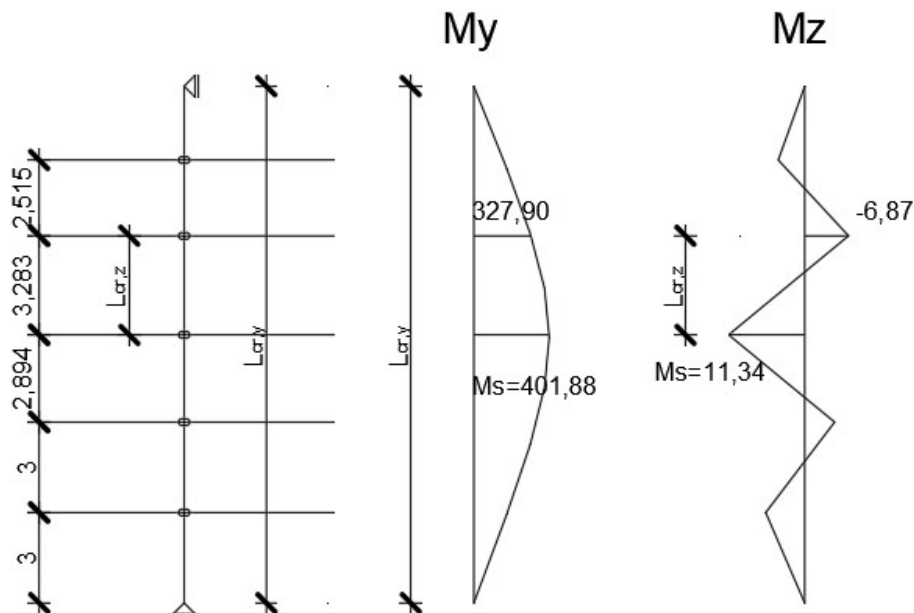

Figure 5.6. Bending moment diagrams for gable column

$$k_{yy} \rightarrow C_{my} \rightarrow M_y \rightarrow L_{cr,y} \Rightarrow C_{my} = 0,95 + 0,05 \cdot \alpha_h = 0,95 + 0,05 \cdot 0 = 0,95$$

$$\alpha_h = 0$$

$$C_{my} = 0,95$$

$$k_{zz} \rightarrow C_{mz} \rightarrow M_z \rightarrow L_{cr,z} \Rightarrow C_{mz} = 0,6 + 0,4 \cdot \psi = 0,6 + 0,4 \cdot (-0,61) = 0,36 < 0,4$$

$$\psi = \frac{-6,87}{11,34} = -0,61$$

$$C_{mz} = 0,4$$

$$k_{zy} \rightarrow C_{mLT} \rightarrow M_y \rightarrow L_{cr,z} \Rightarrow C_{mLT} = 0,95 + 0,05 \cdot \alpha_h = 0,95 + 0,05 \cdot 0,82 = 0,99$$

$$\alpha_h = \frac{327,90}{401,88} = 0,82$$

k_{yy}

$$C_{my} \left(1 + (\lambda_{rel,0,y} - 0,2) \cdot \frac{N_{Ed}}{\frac{\chi_y \cdot N_{Rk}}{\gamma_{M1}}} \right) \leq C_{my} \left(1 + 0,8 \cdot \frac{N_{Ed}}{\frac{\chi_y \cdot N_{Rk}}{\gamma_{M1}}} \right)$$

$$0,95 \cdot \left(1 + (0,94 - 0,2) \cdot \frac{78,02}{\frac{0,71 \cdot 5431,25}{1,0}} \right) \leq 0,95 \cdot \left(1 + 0,8 \cdot \frac{78,02}{\frac{0,71 \cdot 5431,25}{1,0}} \right)$$

$$0,97 \leq 0,97$$

k_{yz}

$$k_{yz} = 0,6 \cdot k_{zz} = 0,6 \cdot 0,4 = 0,24$$

k_{zy}

$$\left[1 - \frac{0,1 \cdot \lambda_{rel,0,z}}{(C_{mLT} - 0,25)} \cdot \frac{N_{Ed}}{\frac{\chi_z \cdot N_{Rk}}{\gamma_{M1}}} \right] \geq \left[1 - \frac{0,1}{(C_{mLT} - 0,25)} \cdot \frac{N_{Ed}}{\frac{\chi_z \cdot N_{Rk}}{\gamma_{M1}}} \right]$$

$$\left[1 - \frac{0,1 \cdot 0,52}{(0,99 - 0,25)} \cdot \frac{78,02}{\frac{0,87 \cdot 5431,25}{1,0}} \right] \geq \left[1 - \frac{0,1}{(0,99 - 0,25)} \cdot \frac{78,02}{\frac{0,87 \cdot 5431,25}{1,0}} \right]$$

$$1,0 \leq 1,0$$

k_{zz}

$$C_{mz} \left(1 + (2 \cdot \lambda_{rel,0,z} - 0,6) \cdot \frac{N_{Ed}}{\frac{\chi_z \cdot N_{Rk}}{\gamma_{M1}}} \right) \leq C_{mz} \left(1 + 1,4 \cdot \frac{N_{Ed}}{\frac{\chi_z \cdot N_{Rk}}{\gamma_{M1}}} \right)$$

$$0,4 \left(1 + (2 \cdot 0,52 - 0,6) \cdot \frac{78,02}{\frac{0,87 \cdot 5431,25}{1,0}} \right) \leq 0,4 \left(1 + 1,4 \cdot \frac{78,02}{\frac{0,87 \cdot 5431,25}{1,0}} \right)$$

$$0,4 \leq 0,41$$

$$k_{yy} = 0,97$$

$$k_{yz} = 0,24$$

$$k_{zy} = 1,0$$

$$k_{zz} = 0,4$$

$$\frac{78,02}{\frac{0,71 \cdot 5431,25}{1,0}} + 0,97 \cdot \frac{401,88}{0,4 \cdot \frac{1085,98}{1,0}} + 0,24 \cdot \frac{11,34}{\frac{291,23}{1,0}} \leq 1,0 \quad (1)$$

$$\frac{78,02}{\frac{0,87 \cdot 5431,25}{1,0}} + 1,0 \cdot \frac{401,88}{0,4 \cdot \frac{1085,98}{1,0}} + 0,4 \cdot \frac{11,34}{\frac{291,23}{1,0}} \leq 1,0 \quad (2)$$

$$0,93 \leq 1,0 \quad (1)$$

$$0,96 \leq 1,0 \quad (2)$$

4) Buckling of uniform members in bending

$$\frac{M_{Ed}}{M_{b,Rd}} \leq 1,0$$

$$M_{b,Rd} = \chi_{LT} \cdot W_y \cdot \frac{f_y}{\gamma_{M1}}$$

$$W_y = W_{pl,y} \rightarrow \text{for class 2}$$

$$\chi_{LT} = 0,4 \rightarrow \text{calculated in (3)}$$

$$M_{b,Rd} = 0,4 \cdot 3949 \cdot 10^3 \cdot 10^{-9} \cdot \frac{275 \cdot 10^3}{1,0}$$

$$M_{b,Rd} = 434,39 \text{ kNm}$$

$$\frac{401,88}{434,39} = 0,93 \leq 1,0$$

5.2 Upper cord (CFCHS 168.3x6)

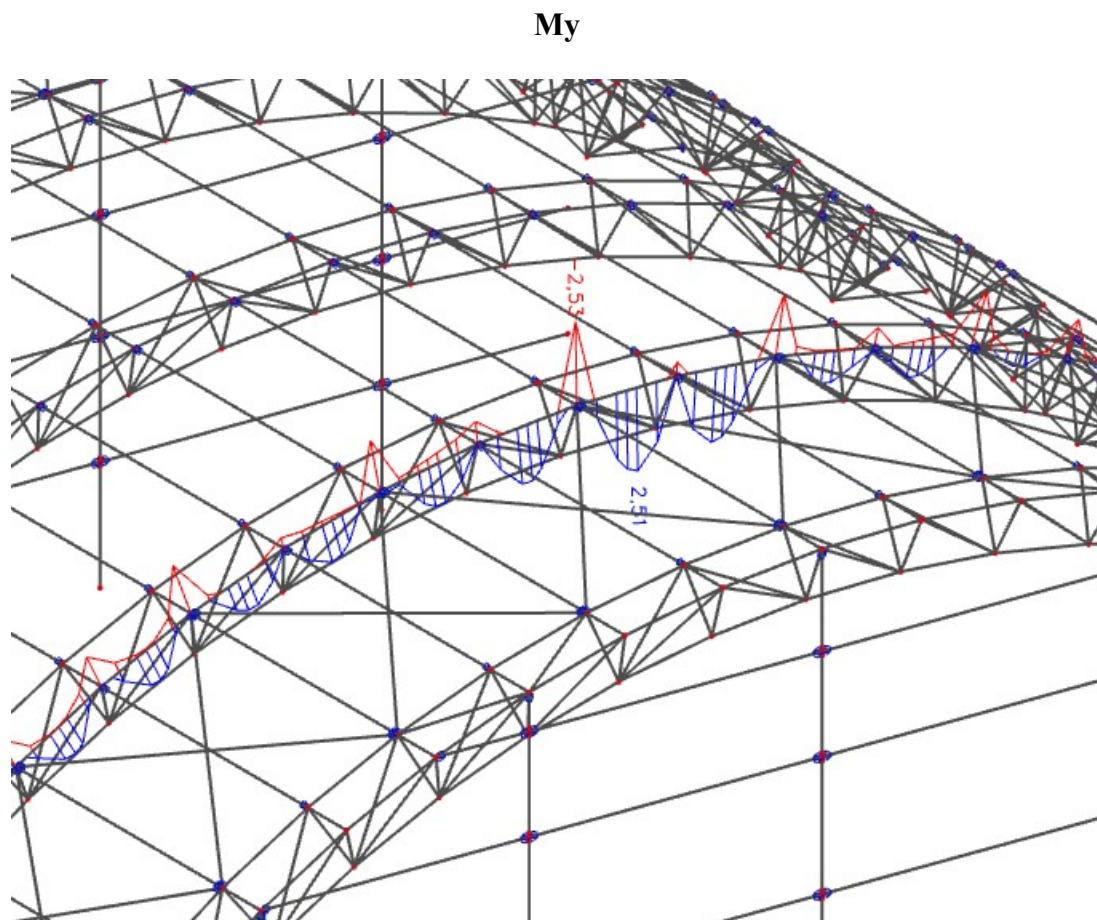

Figure 5.7. Bending moment diagram (My)

V_z

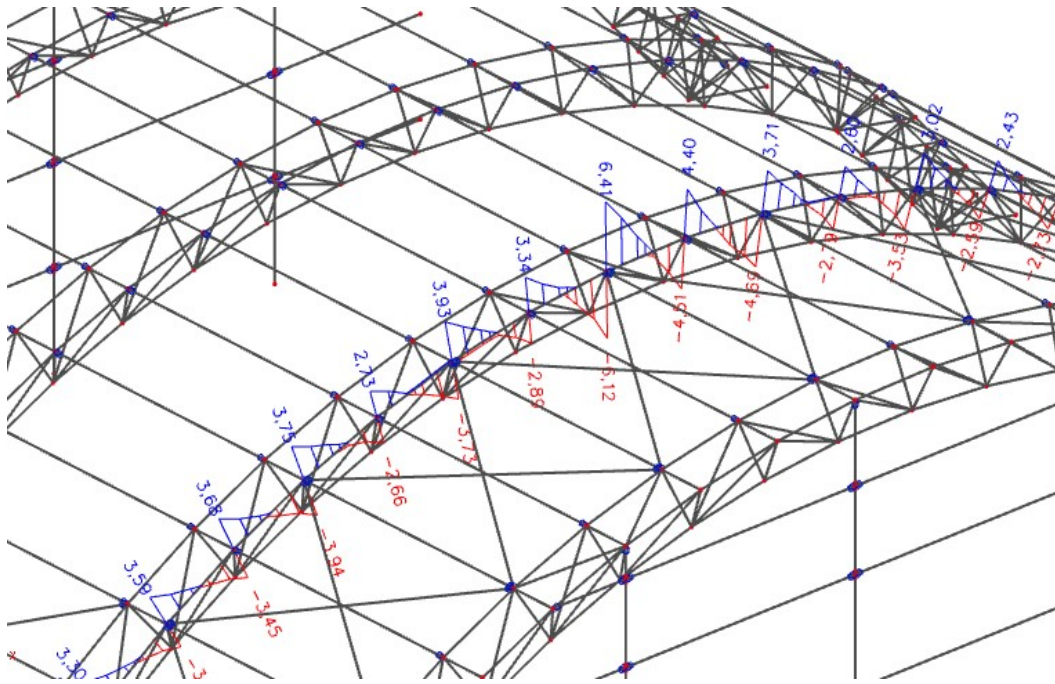

Figure 5.8. Shear force diagram (V_z)

M_z

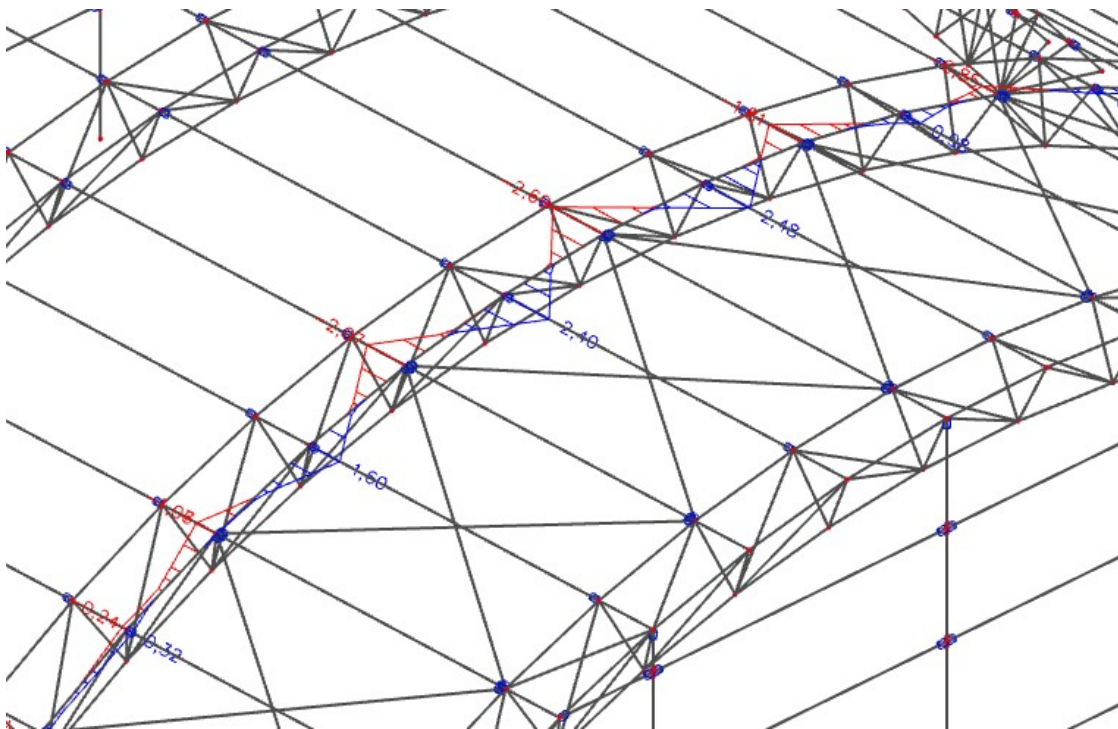

Figure 5.9. Bending moment diagram (M_z)

V_y

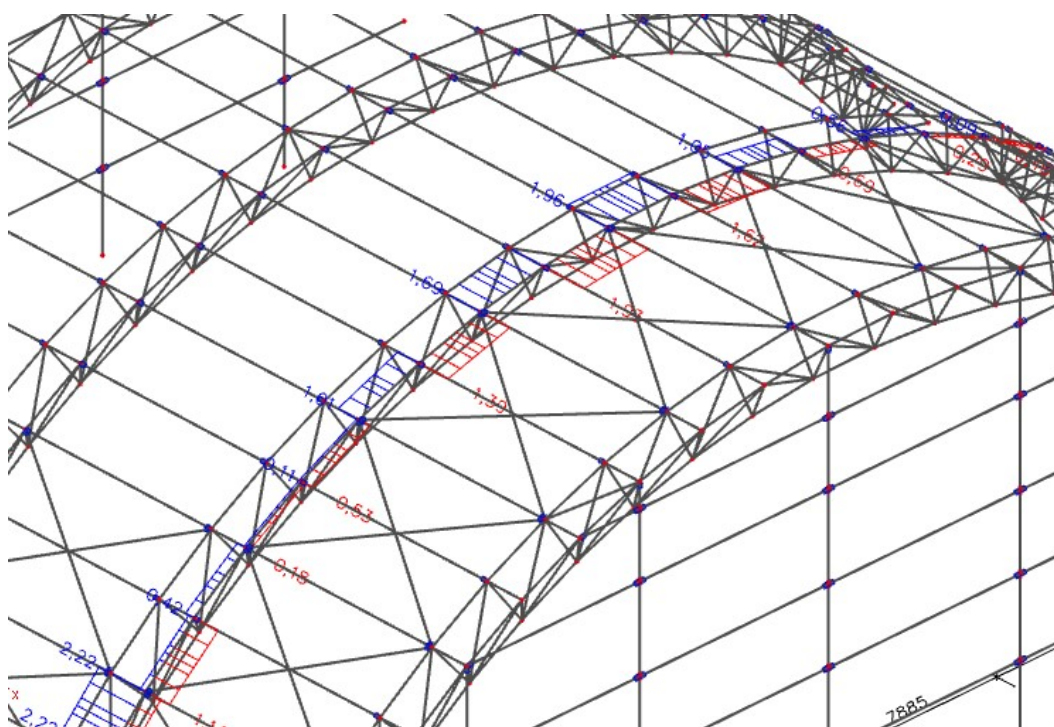

Figure 5.10. Shear force diagram (V_y)

N

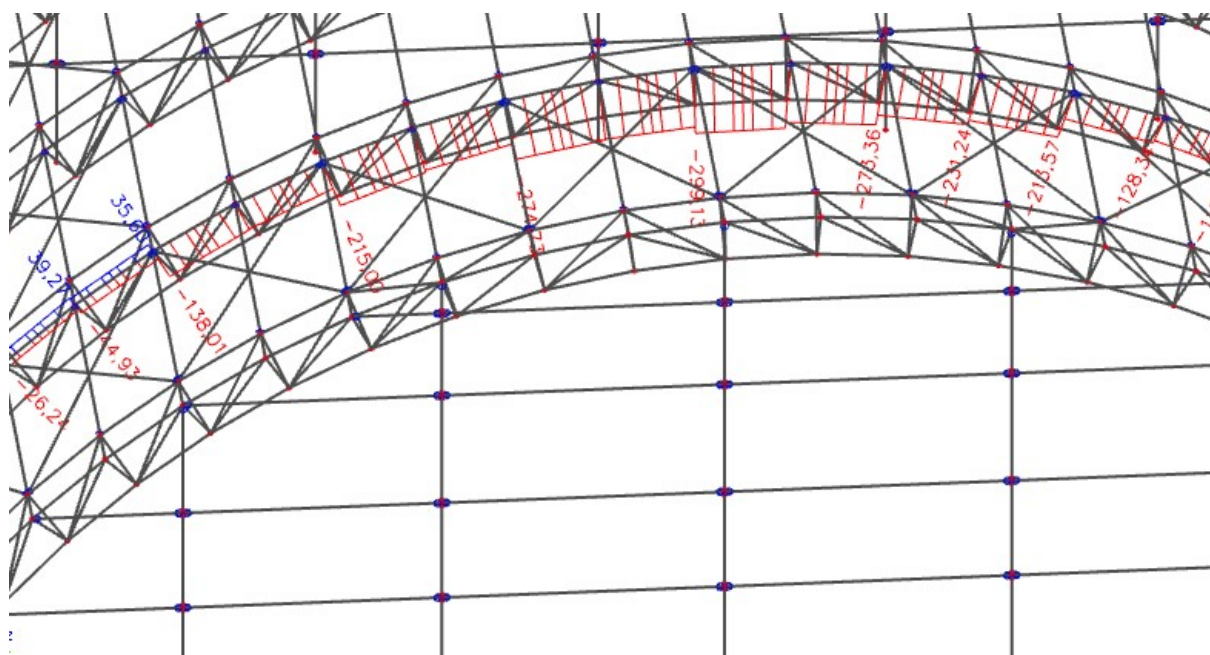

Figure 5.11. Axial force diagram (N)

Relevant combination: ULS3

$$\text{gsn3} / 1.35 \cdot \text{LC1} + 1.50 \cdot \text{snow} + 1.35 \cdot \text{constant load} + 1.05 \cdot \text{work+inst2}$$

$$N = 299,13 \text{ kN (compression)}$$

$$M_y = -2,53 \text{ kNm}$$

$$V_z = 6,41 \text{ kN}$$

$$M_z = -2,69 \text{ kNm}$$

$$V_y = 1,96 \text{ kN}$$

- Classification of gable column (CFCHS 168.3x6)

- Section in bending and/or compression

$$\frac{d}{t} \leq 50 \cdot \varepsilon^2$$

$$\frac{168.3}{6} = 28,05 \leq 42,32 \quad \text{class 1}$$

Cross section is in Class 1

1) Compression check

$$\frac{N_{Ed}}{N_{c,Rd}} \leq 1,0$$

$$N_{c,Rd} = \frac{A \cdot f_y}{\gamma_{M0}} = \frac{3,059 \cdot 10^{-3} \cdot 275 \cdot 10^3}{1,0} = 841,23 \text{ kN}$$

$$\frac{299,13}{841,23} = 0,36 < 1,0$$

2) Bending moment check for M_y

$$W_{pl,y} = 1,5812 \cdot 10^{-4} \text{ m}^3$$

$$\frac{M_{Ed}}{M_{c,Rd}} \leq 1,0$$

$$M_{c,Rd} = M_{pl,Rd} = \frac{W_{pl,y} \cdot f_y}{\gamma_{M0}} = \frac{1,5812 \cdot 10^{-4} \cdot 275 \cdot 10^3}{1,0} = 43,48 \text{ kN}$$

$$\frac{2,53}{43,48} = 0,1 < 1,0$$

3) Bending moment check for Mz

$$W_{pl,z} = 1,5812 \cdot 10^{-4} \text{ m}^3$$

$$\frac{M_{Ed}}{M_{c,Rd}} \leq 1,0$$

$$M_{c,Rd} = M_{pl,Rd} = \frac{W_{pl,z} \cdot f_y}{\gamma_{M0}} = \frac{1,5812 \cdot 10^{-4} \cdot 275 \cdot 10^3}{1,0} = 43,48 \text{ kN}$$

$$\frac{2,69}{43,48} = 0,1 < 1,0$$

4) Shear check for Vy

$$\frac{V_{Ed}}{V_{c,Rd}} \leq 1,0$$

$$V_{c,Rd} = V_{pl,Rd} = \frac{A_v \cdot f_y}{\gamma_{M0} \cdot \sqrt{3}}$$

⇒ A_v for circular hollow section is:

$$A_v = \frac{2 \cdot A}{\pi} = \frac{2 \cdot 3,059 \cdot 10^{-3}}{\pi} = 1,9474 \cdot 10^{-3} \text{ m}^2$$

$$V_{pl,Rd} = \frac{1,9474 \cdot 10^{-3} \cdot 275 \cdot 10^3}{1,0 \cdot \sqrt{3}} = 309,19 \text{ kN}$$

$$\frac{1,96}{309,19} = 0,01 < 1,0$$

5) Shear check for Vz

$$\frac{V_{Ed}}{V_{c,Rd}} \leq 1,0$$

$$V_{c,Rd} = V_{pl,Rd} = \frac{A_v \cdot f_y}{\gamma_{M0} \cdot \sqrt{3}}$$

⇒ A_v for circular hollow section is:

$$A_v = \frac{2 \cdot A}{\pi} = \frac{2 \cdot 3,059 \cdot 10^{-3}}{\pi} = 1,9474 \cdot 10^{-3} \text{ m}^2$$

$$V_{pl,Rd} = \frac{1,9474 \cdot 10^{-3} \cdot 275 \cdot 10^3}{1,0 \cdot \sqrt{3}} = 309,19 \text{ kN}$$

$$\frac{6,41}{309,19} = 0,02 < 1,0$$

6) Combined bending, axial force and shear force check

$$M_{Ed} \leq M_{N,Rd}$$

$V_{pl,Rd} = 309,19 \text{ kN}$; $V_{Ed} = 6,38$ → since the shear forces are less than half the plastic shear resistance their effect on the moment resistance is neglected

$$N_{pl,Rd} = \frac{A \cdot f_y}{\gamma_{M0}} = \frac{3,059 \cdot 10^{-3} \cdot 275 \cdot 10^3}{1,0} = 841,23 \text{ kN}$$

$$N_{Ed} = 299,13 \text{ kN}$$

$$n = \frac{N_{Ed}}{N_{pl,Rd}} = \frac{299,13}{841,23} = 0,36$$

$$M_{N,y,Rd} = M_{pl,y,Rd} \cdot \frac{1 - n}{1 - 0,5 \cdot a_w}$$

$$a_w = \frac{A - 2 \cdot b \cdot t}{A} = \frac{3,059 \cdot 10^{-3} - 2 \cdot 168,3 \cdot 10^{-3} \cdot 6 \cdot 10^{-3}}{3,059 \cdot 10^{-3}}$$

$$a_w = 0,34$$

$$M_{N,y,Rd} = 43,48 \cdot \frac{1 - 0,36}{1 - 0,5 \cdot 0,34}$$

$$M_{N,y,Rd} = 33,53 \text{ kNm}$$

$$\left[\frac{M_{y,Ed}}{M_{N,y,Rd}} \right]^\alpha + \left[\frac{M_{z,Ed}}{M_{N,z,Rd}} \right]^\beta$$

$\alpha = 2, \beta = 2 \rightarrow$ for circular hollow section

$$\left[\frac{2,53}{33,53} \right]^2 + \left[\frac{2,69}{33,53} \right]^2 \leq 1,0$$

$$0,01 \leq 1,0$$

7) Buckling of uniform members in compression

$$\frac{N_{Ed}}{N_{b,Rd}} \leq 1,0$$

$$N_{b,Rd} = \frac{\chi \cdot A \cdot f_y}{\gamma_{M0}}$$

$$\lambda_1 = 93,9 \cdot \varepsilon = 93,9 \cdot 0,92 = 86,39$$

Y	Z
$\lambda_{rel,0,y} = \frac{L_{cr,y}}{i_y} \cdot \frac{1}{\lambda_1} = \frac{2642}{57} \cdot \frac{1}{86,39}$	$\lambda_{rel,0,z} = \frac{L_{cr,z}}{i_z} \cdot \frac{1}{\lambda_1} = \frac{5284}{57} \cdot \frac{1}{86,39}$
$\lambda_{rel,0,y} = 0,54$	$\lambda_{rel,0,z} = 1,07$
$\chi_y = \frac{1}{\Phi_y + \sqrt{\Phi_y^2 - \lambda_{rel,0,y}^2}}$	$\chi_z = \frac{1}{\Phi_z + \sqrt{\Phi_z^2 - \lambda_{rel,0,z}^2}}$
$\Phi_y = 0,5(1 + \alpha(\lambda_{rel,0,y} - 0,2) + \lambda_{rel,0,y}^2)$	$\Phi_z = 0,5(1 + \alpha(\lambda_{rel,0,z} - 0,2) + \lambda_{rel,0,z}^2)$
Buckling curve	Buckling curve
y-y => c $\rightarrow \alpha = 0,49$	z-z => c $\rightarrow \alpha = 0,49$
$\Phi_y = 0,5(1 + 0,49(0,54 - 0,2) + 0,54^2)$	$\Phi_z = 0,5(1 + 0,49(1,07 - 0,2) + 1,07^2)$
$\Phi_y = 0,73$	$\Phi_z = 1,29$

$\chi_y = \frac{1}{0,73 + \sqrt{0,73^2 - 0,54^2}}$ $\chi_y = 0,82$ $N_{b,Rd} = \frac{0,82 \cdot 3,059 \cdot 10^{-3} \cdot 275 \cdot 10^3}{1,0}$ $N_{b,Rd,y} = 689,8 \text{ kN}$	$\chi_z = \frac{1}{1,29 + \sqrt{1,29^2 - 1,07^2}}$ $\chi_z = 0,50$ $N_{b,Rd} = \frac{0,5 \cdot 3,059 \cdot 10^{-3} \cdot 275 \cdot 10^3}{1,0}$ $N_{b,Rd,z} = 420,61 \text{ kN}$
---	---

$$\frac{299,13}{420,61} = 0,71 \leq 1,0$$

8) Uniform members in bending and axial compression

$$\frac{N_{Ed}}{\chi_y \cdot N_{Rk}} + k_{yy} \cdot \frac{M_{y,Ed}}{\chi_{LT} \cdot \frac{M_{y,Rk}}{\gamma_{M1}}} + k_{yz} \cdot \frac{M_{z,Ed}}{\frac{M_{z,Rk}}{\gamma_{M1}}} \leq 1,0 \quad (1)$$

$$\frac{N_{Ed}}{\chi_z \cdot N_{Rk}} + k_{zy} \cdot \frac{M_{y,Ed}}{\chi_{LT} \cdot \frac{M_{y,Rk}}{\gamma_{M1}}} + k_{zz} \cdot \frac{M_{z,Ed}}{\frac{M_{z,Rk}}{\gamma_{M1}}} \leq 1,0 \quad (2)$$

$$N_{Rk} = f_y \cdot A_i = 275 \cdot 10^3 \cdot 3,059 \cdot 10^{-3} = 841,23 \text{ kN}$$

$$M_{y,Rk} = f_y \cdot W_{pl,y} = 275 \cdot 10^3 \cdot 1,5812 \cdot 10^{-4} = 43,48 \text{ kNm}$$

$$M_{z,Rk} = f_y \cdot W_{pl,z} = 43,48 \text{ kNm}$$

$$\chi_y = 0,82$$

$$\lambda_{rel,0,y} = 0,54$$

$$\chi_z = 0,50$$

$$\lambda_{rel,0,z} = 1,07$$

$$\chi_{LT} = 1,0 \rightarrow \text{circular hollow section are not susceptible to torsional deformation}$$

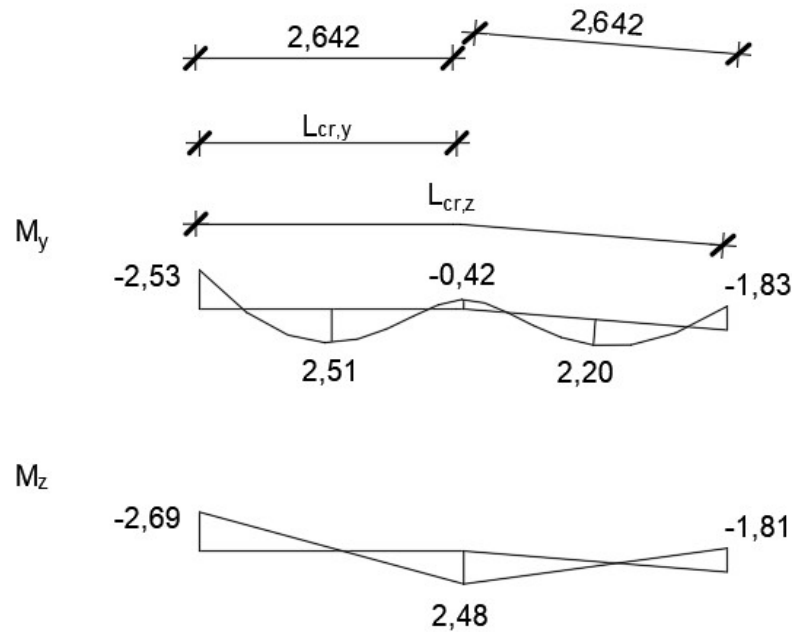

Figure 5.12. Bending moment diagrams for upper cord

$$k_{yy} \rightarrow C_{my} \rightarrow M_y \rightarrow L_{cr,y} \Rightarrow C_{my} = 0,1 - 0,8 \cdot \alpha_s = 0,1 + 0,8 \cdot (-0,99) = 0,89 \geq 0,4$$

$$\alpha_s = \frac{2,51}{-2,53} = -0,99$$

$$\psi = \frac{-0,42}{-2,53} = 0,17$$

$$C_{my} = 0,89$$

$$k_{zz} \rightarrow C_{mz} \rightarrow M_z \rightarrow L_{cr,z} \Rightarrow C_{mz} = -0,8 \cdot \alpha_s = -0,8 \cdot (-0,92) = 0,74 > 0,4$$

$$\psi = \frac{-1,81}{-2,69} = 0,67$$

$$\alpha_s = \frac{2,48}{-2,69} = -0,92$$

$$C_{mz} = 0,74$$

k_{yy}

$$C_{my} \left(1 + (\lambda_{rel,0,y} - 0,2) \cdot \frac{N_{Ed}}{\frac{\chi_y \cdot N_{Rk}}{\gamma_{M1}}} \right) \leq C_{my} \left(1 + 0,8 \cdot \frac{N_{Ed}}{\frac{\chi_y \cdot N_{Rk}}{\gamma_{M1}}} \right)$$

$$0,89 \cdot \left(1 + (0,54 - 0,2) \cdot \frac{299,13}{\frac{0,82 \cdot 841,23}{1,0}} \right) \leq 0,89 \cdot \left(1 + 0,8 \cdot \frac{299,13}{\frac{0,82 \cdot 841,23}{1,0}} \right)$$

$$1,02 \leq 1,2$$

k_{yz}

$$k_{yz} = 0,6 \cdot k_{zz} = 0,6 \cdot 1,16 = 0,7$$

k_{zy}

$$k_{zy} = 0,6 \cdot k_{yy} = 0,6 \cdot 1,02 = 0,61$$

k_{zz}

$$C_{mz} \left(1 + (\lambda_{rel,0,z} - 0,2) \cdot \frac{N_{Ed}}{\frac{\chi_z \cdot N_{Rk}}{\gamma_{M1}}} \right) \leq C_{mz} \left(1 + 0,8 \cdot \frac{N_{Ed}}{\frac{\chi_z \cdot N_{Rk}}{\gamma_{M1}}} \right)$$

$$0,74 \left(1 + (1,07 - 0,2) \cdot \frac{299,13}{\frac{0,5 \cdot 841,23}{1,0}} \right) \leq 0,74 \left(1 + 0,8 \cdot \frac{299,13}{\frac{0,5 \cdot 841,23}{1,0}} \right)$$

$$1,2 > 1,16$$

$$k_{yy} = 1,02$$

$$k_{yz} = 0,7$$

$$k_{zy} = 0,61$$

$$k_{zz} = 1,16$$

$$\frac{299,13}{\frac{0,82 \cdot 841,23}{1,0}} + 1,02 \cdot \frac{2,53}{1,0 \cdot \frac{43,48}{1,0}} + 0,7 \cdot \frac{2,69}{\frac{43,48}{1,0}} \leq 1,0 \quad (1)$$

$$\frac{299,13}{\frac{0,50 \cdot 841,23}{1,0}} + 0,61 \cdot \frac{2,53}{1,0 \cdot \frac{43,48}{1,0}} + 1,16 \cdot \frac{2,69}{\frac{43,48}{1,0}} \leq 1,0 \quad (2)$$

$$0,54 \leq 1,0 \quad (1)$$

$$0,82 \leq 1,0 \quad (2)$$

5.3 lower cord 1 (CFCHS 193.7x5)

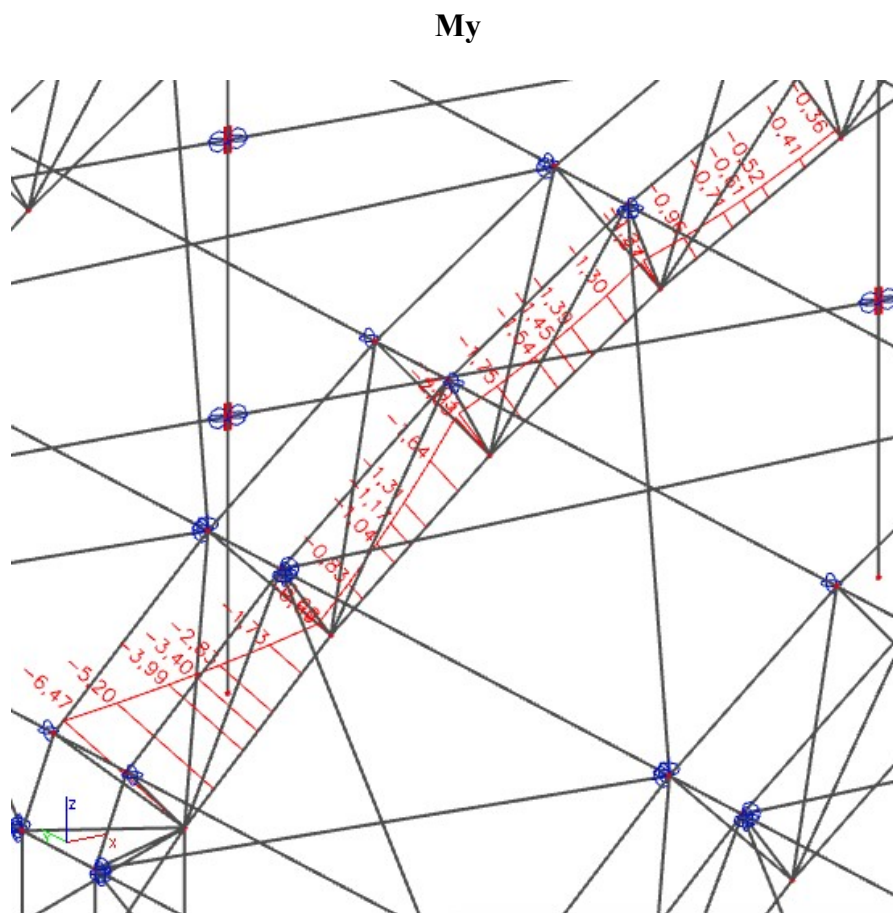

Figure 5.13. Bending moment diagram (My)

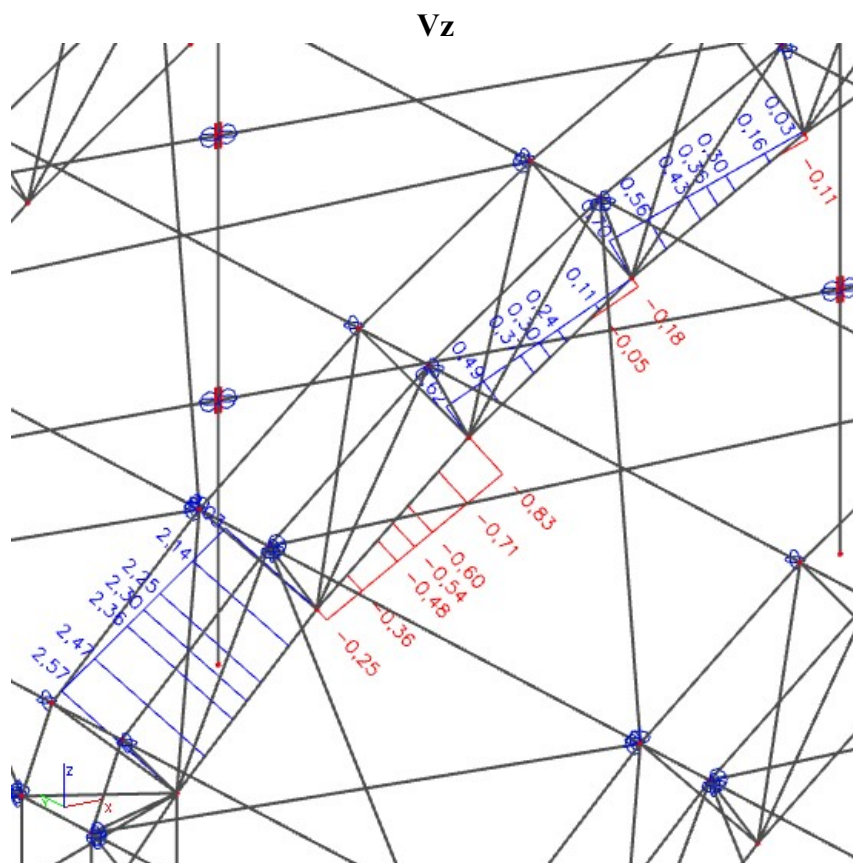

Figure 5.14. Shear force diagram (V_z)

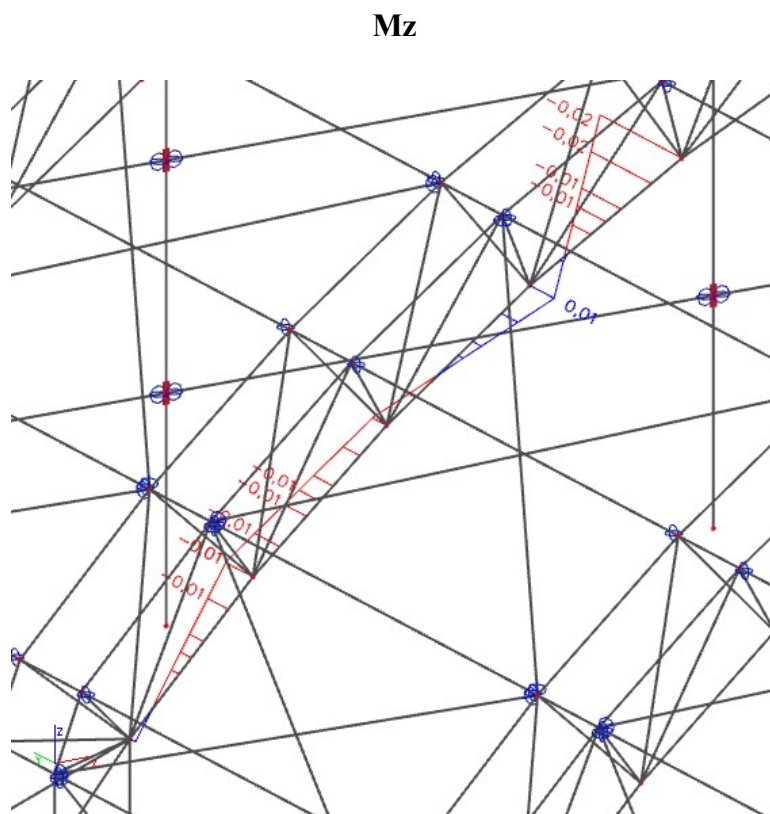

Figure 5.15. Bending moment diagram (M_z)

V_y

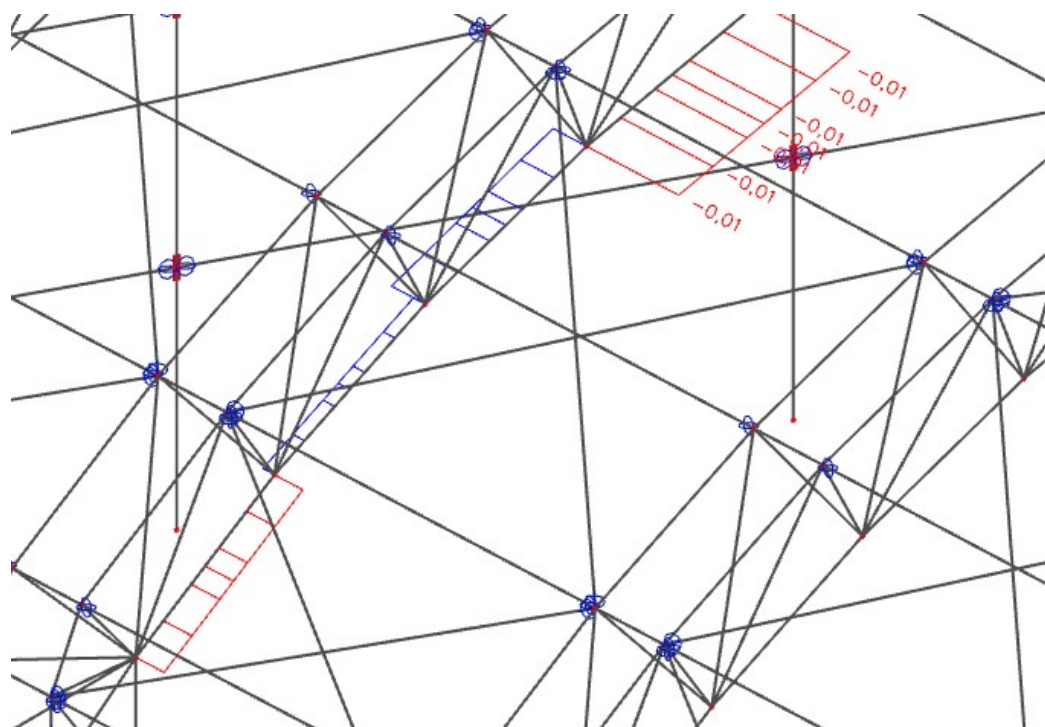

Figure 5.16. Shear force diagram (V_y)

N

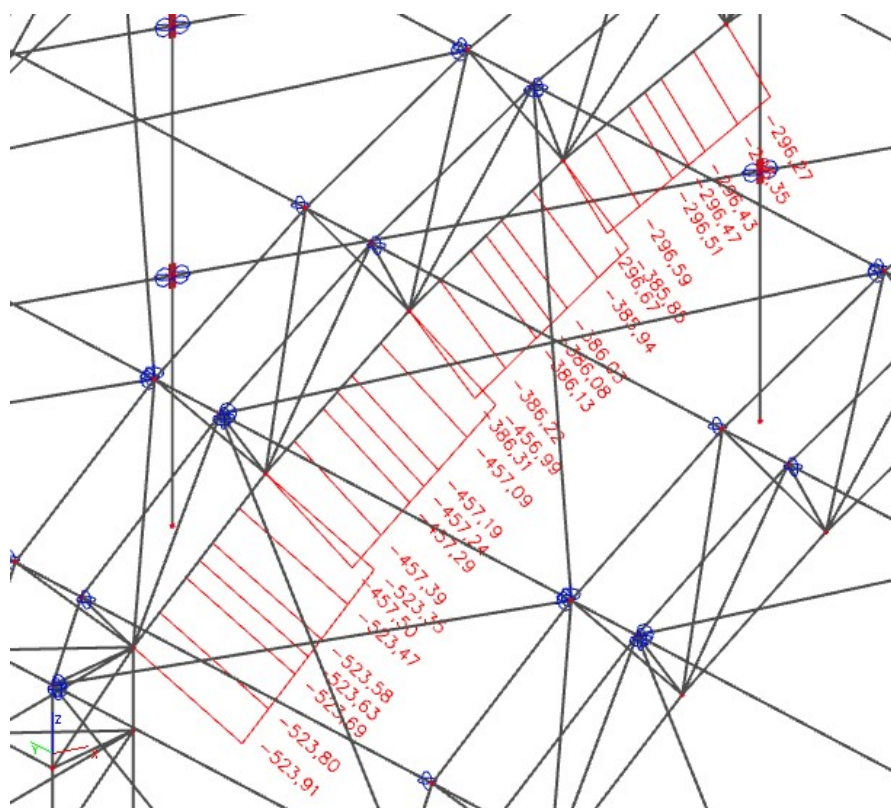

Figure 5.17. Axial force diagram (V_z)

Relevant combination: ULS38

gsn38 / 1.35*LC1 + 1.50*snow + 1.35*constant load +
1.05*work+inst2

$N = -457,50 \text{ kN}$ (compression)

$M_y = -0,69 \text{ kNm}$

$V_z = -0,25 \text{ kN}$

$M_z = 0,01 \text{ kNm}$

$V_y = 0 \text{ kN}$

- Classification of gable column (CFCHS 193.7x5)

- Section in bending and/or compression

$$\frac{d}{t} \leq 50 \cdot \varepsilon^2$$

$$\frac{193,7}{5} = 38,74 \leq 42,32 \quad \text{class 1}$$

Cross section is in Class 1

1) Compression check

$$\frac{N_{Ed}}{N_{c,Rd}} \leq 1,0$$

$$N_{c,Rd} = \frac{A \cdot f_y}{\gamma_{M0}} = \frac{2,964 \cdot 10^{-3} \cdot 275 \cdot 10^3}{1,0} = 815,1 \text{ kN}$$

$$\frac{457,50}{815,1} = 0,56 < 1,0$$

2) Bending moment check for M_y

$$W_{pl,y} = 1,7808 \cdot 10^{-4} \text{ m}^3$$

$$\frac{M_{Ed}}{M_{c,Rd}} \leq 1,0$$

$$M_{c,Rd} = M_{pl,Rd} = \frac{W_{pl,y} \cdot f_y}{\gamma_{M0}} = \frac{1,7808 \cdot 10^{-4} \cdot 275 \cdot 10^3}{1,0} = 48,97 \text{ kN}$$

$$\frac{0,69}{48,97} = 0,01 < 1,0$$

3) Shear check for Vz

$$\frac{V_{Ed}}{V_{c,Rd}} \leq 1,0$$

$$V_{c,Rd} = V_{pl,Rd} = \frac{A_v \cdot f_y}{\gamma_{M0} \cdot \sqrt{3}}$$

⇒ A_v for circular hollow section is:

$$A_v = \frac{2 \cdot A}{\pi} = \frac{2 \cdot 2,964 \cdot 10^{-3}}{\pi} = 1,8869 \cdot 10^{-3} \text{ m}^2$$

$$V_{pl,Rd} = \frac{1,8869 \cdot 10^{-3} \cdot 275 \cdot 10^3}{1,0 \cdot \sqrt{3}} = 299,59 \text{ kN}$$

$$\frac{0,25}{299,59} = 0,0 < 1,0$$

4) Combined bending, axial force and shear force check

$$M_{Ed} \leq M_{N,Rd}$$

$V_{pl,Rd} = 299,59 \text{ kN}$; $V_{Ed} = 0,38$ → since the shear forces are less than half the plastic shear resistance their effect on the moment resistance is neglected

$$N_{pl,Rd} = \frac{A \cdot f_y}{\gamma_{M0}} = \frac{2,964 \cdot 10^{-3} \cdot 275 \cdot 10^3}{1,0} = 815,1 \text{ kN}$$

$$N_{Ed} = 457,50 \text{ kN}$$

$$n = \frac{N_{Ed}}{N_{pl,Rd}} = \frac{457,50}{815,1} = 0,56$$

$$M_{N,y,Rd} = M_{pl,y,Rd} \cdot \frac{1 - n}{1 - 0,5 \cdot a_w}$$

$$a_w = \frac{A - 2 \cdot b \cdot t}{A} = \frac{2,964 \cdot 10^{-3} - 2 \cdot 193,7 \cdot 10^{-3} \cdot 5 \cdot 10^{-3}}{2,964 \cdot 10^{-3}}$$

$$a_w = 0,35$$

$$M_{N,y,Rd} = 48,97 \cdot \frac{1 - 0,56}{1 - 0,5 \cdot 0,35}$$

$$M_{N,y,Rd} = 26,12 \text{ kNm}$$

$$\left[\frac{M_{y,Ed}}{M_{N,y,Rd}} \right]^\alpha + \left[\frac{M_{z,Ed}}{M_{N,z,Rd}} \right]^\beta$$

$\alpha = 2, \beta = 2 \rightarrow$ for circular hollow section

$$\left[\frac{0,69}{26,12} \right]^2 + [0]^2 \leq 1,0$$

$$0,01 \leq 1,0$$

5) Buckling of uniform members in compression

$$\frac{N_{Ed}}{N_{b,Rd}} \leq 1,0$$

$$N_{b,Rd} = \frac{\chi \cdot A \cdot f_y}{\gamma_{M0}}$$

$$\lambda_1 = 93,9 \cdot \varepsilon = 93,9 \cdot 0,92 = 86,39$$

Y	Z
$\lambda_{rel,0,y} = \frac{L_{cr,y}}{i_y} \cdot \frac{1}{\lambda_1} = \frac{2511}{67} \cdot \frac{1}{86,39}$	$\lambda_{rel,0,z} = \frac{L_{cr,z}}{i_z} \cdot \frac{1}{\lambda_1} = \frac{5022}{67} \cdot \frac{1}{86,39}$
$\lambda_{rel,0,y} = \mathbf{0,43}$	$\lambda_{rel,0,z} = \mathbf{0,87}$
$\chi_y = \frac{1}{\Phi_y + \sqrt{\Phi_y^2 - \lambda_{rel,0,y}^2}}$	$\chi_z = \frac{1}{\Phi_z + \sqrt{\Phi_z^2 - \lambda_{rel,0,z}^2}}$
$\Phi_y = 0,5(1 + \alpha(\lambda_{rel,0,y} - 0,2) + \lambda_{rel,0,y}^2)$	$\Phi_z = 0,5(1 + \alpha(\lambda_{rel,0,z} - 0,2) + \lambda_{rel,0,z}^2)$

<p>Buckling curve</p> <p>$y-y \Rightarrow c \rightarrow \alpha = 0,49$</p> <p>$\Phi_y = 0,5(1 + 0,49(0,43 - 0,2) + 0,43^2)$</p> <p>$\Phi_y = 0,649$</p> $\chi_y = \frac{1}{0,649 + \sqrt{0,649^2 - 0,43^2}}$ <p>$\chi_y = 0,88$</p> <p>$N_{b,Rd} = \frac{0,88 \cdot 2,964 \cdot 10^{-3} \cdot 275 \cdot 10^3}{1,0}$</p> <p>$N_{b,Rd,y} = 717,29 \text{ kN}$</p>	<p>Buckling curve</p> <p>$z-z \Rightarrow c \rightarrow \alpha = 0,49$</p> <p>$\Phi_z = 0,5(1 + 0,49(0,87 - 0,2) + 0,87^2)$</p> <p>$\Phi_z = 1,043$</p> $\chi_z = \frac{1}{1,043 + \sqrt{1,043^2 - 0,87^2}}$ <p>$\chi_z = 0,62$</p> <p>$N_{b,Rd} = \frac{0,5 \cdot 2,964 \cdot 10^{-3} \cdot 275 \cdot 10^3}{1,0}$</p> <p>$N_{b,Rd,z} = 505,36 \text{ kN}$</p>
---	--

$$\frac{457,5}{505,36} = 0,91 \leq 1,0$$

6) Uniform members in bending and axial compression

$$\frac{N_{Ed}}{\chi_y \cdot N_{Rk}} + k_{yy} \cdot \frac{M_{y,Ed}}{\chi_{LT} \cdot \frac{M_{y,Rk}}{\gamma_{M1}}} + k_{yz} \cdot \frac{M_{z,Ed}}{\frac{M_{z,Rk}}{\gamma_{M1}}} \leq 1,0 \quad (1)$$

$$\frac{N_{Ed}}{\chi_z \cdot N_{Rk}} + k_{zy} \cdot \frac{M_{y,Ed}}{\chi_{LT} \cdot \frac{M_{y,Rk}}{\gamma_{M1}}} + k_{zz} \cdot \frac{M_{z,Ed}}{\frac{M_{z,Rk}}{\gamma_{M1}}} \leq 1,0 \quad (2)$$

$$N_{Rk} = f_y \cdot A_i = 275 \cdot 10^3 \cdot 2,964 \cdot 10^{-3} = 815,1 \text{ kN}$$

$$M_{y,Rk} = f_y \cdot W_{pl,y} = 275 \cdot 10^3 \cdot 1,7808 \cdot 10^{-4} = 48,97 \text{ kNm}$$

$$M_{z,Rk} = f_y \cdot W_{pl,z} = 48,97 \text{ kNm}$$

$$N_{Ed} = 457,50 \text{ kN}$$

$$M_{y,Ed} = -2,03 \text{ kNm}$$

$$M_{z,Ed} = 0,01 \text{ kNm}$$

$$\chi_y = 0,88$$

$$\lambda_{rel,0,y} = 0,43$$

$$\chi_z = 0,62$$

$$\lambda_{rel,0,z} = 0,87$$

$\chi_{LT} = 1,0$ → circular hollow section are not susceptible to torsional deformation

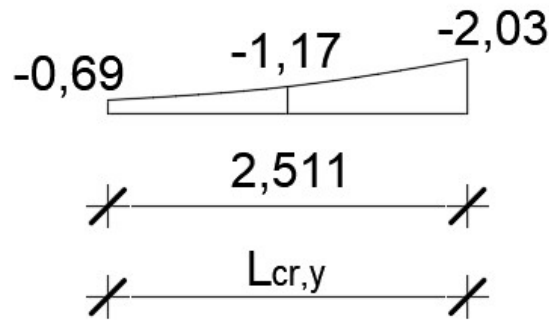

Figure 5.18. Bending moment diagrams for lower cord

$$k_{yy} \rightarrow C_{my} \rightarrow M_y \rightarrow L_{cr,y} \Rightarrow C_{my} = 0,2 + 0,8 \cdot \alpha_s = 0,2 + 0,8 \cdot 0,58 = 0,66 \geq 0,4$$

$$\alpha_s = \frac{-1,17}{-2,03} = 0,58$$

$$\psi = \frac{-0,69}{-2,03} = 0,34$$

$$C_{my} = 0,66$$

k_{yy}

$$C_{my} \left(1 + (\lambda_{rel,0,y} - 0,2) \cdot \frac{N_{Ed}}{\frac{\chi_y \cdot N_{Rk}}{\gamma_{M1}}} \right) \leq C_{my} \left(1 + 0,8 \cdot \frac{N_{Ed}}{\frac{\chi_y \cdot N_{Rk}}{\gamma_{M1}}} \right)$$

$$0,66 \cdot \left(1 + (0,43 - 0,2) \cdot \frac{457,50}{\frac{0,88 \cdot 815,1}{1,0}} \right) \leq 0,66 \cdot \left(1 + 0,8 \cdot \frac{457,50}{\frac{0,88 \cdot 815,1}{1,0}} \right)$$

$$0,76 \leq 1,0$$

$$k_{yy} = 0,76$$

$$k_{zy} = 0,6 \cdot k_{yy} = 0,6 \cdot 0,76 = 0,46$$

$$\frac{457,50}{\frac{0,88 \cdot 815,1}{1,0}} + 0,76 \cdot \frac{2,03}{1,0 \cdot \frac{48,97}{1,0}} \leq 1,0 \quad (1)$$

$$\frac{457,50}{\frac{0,62 \cdot 815,1}{1,0}} + 0,46 \cdot \frac{2,03}{1,0 \cdot \frac{48,97}{1,0}} \leq 1,0 \quad (2)$$

$$0,67 \leq 1,0 \quad (1)$$

$$0,92 \leq 1,0 \quad (2)$$

5.4 Lower cord 2 (CFCHS 139.7x4)

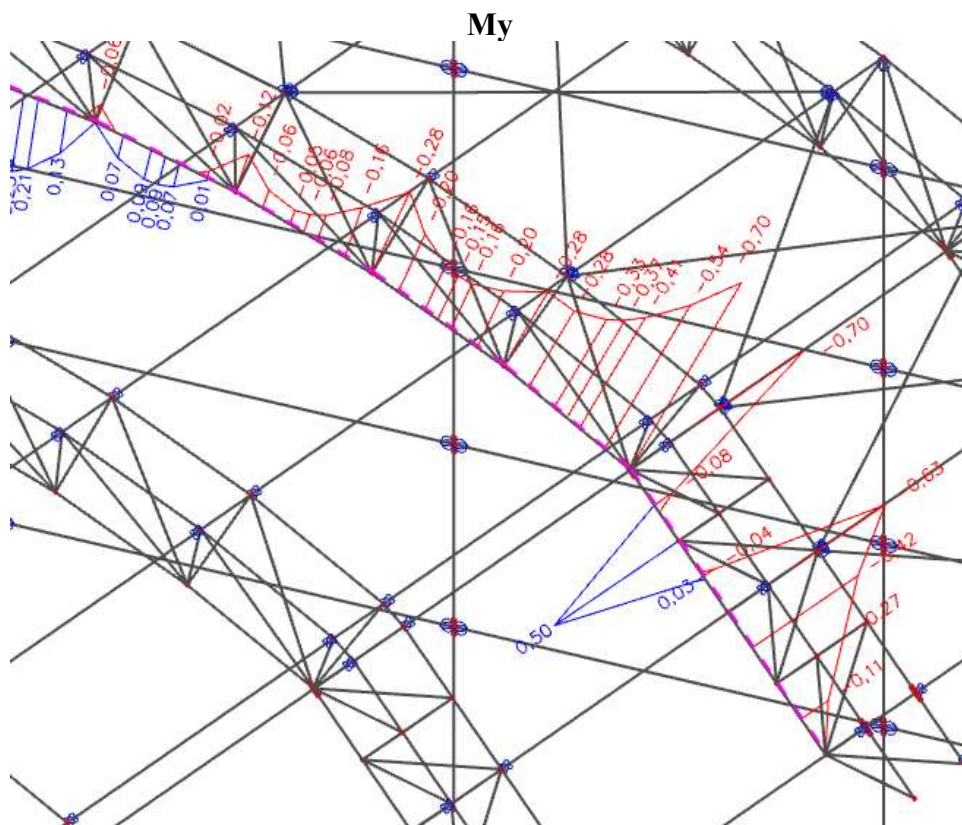

Figure 5.19. Bending moment diagram (My)

V_z

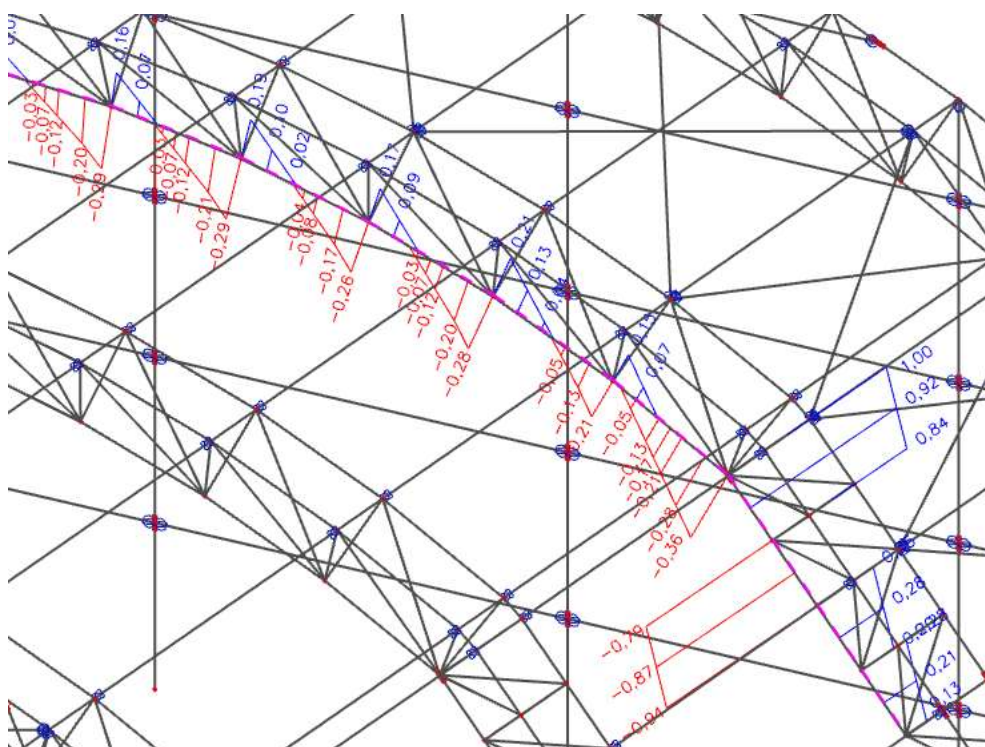

Figure 5.20. Shear force diagram (V_z)

M_z

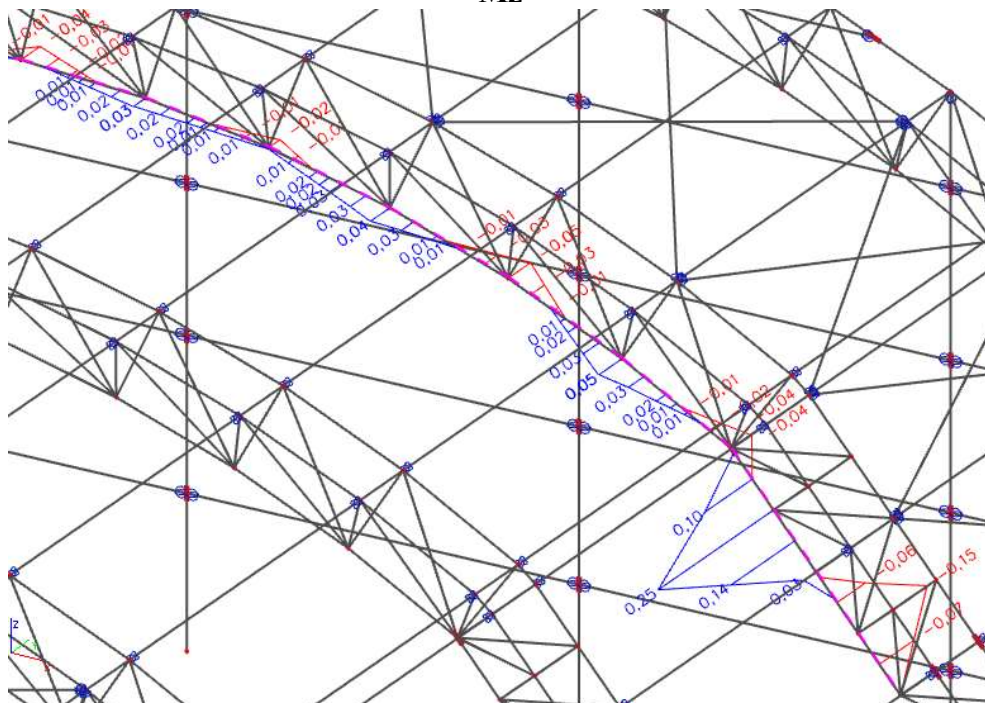

Figure 5.21. Bending moment diagram (M_z)

V_y

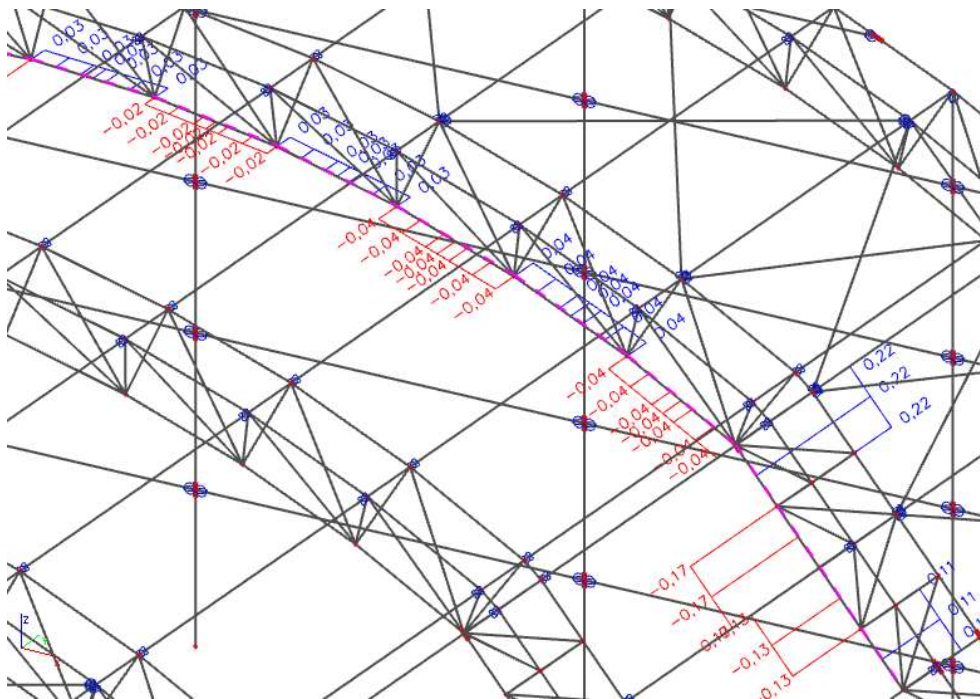

Figure 5.22. Shear force diagram (V_y)

N

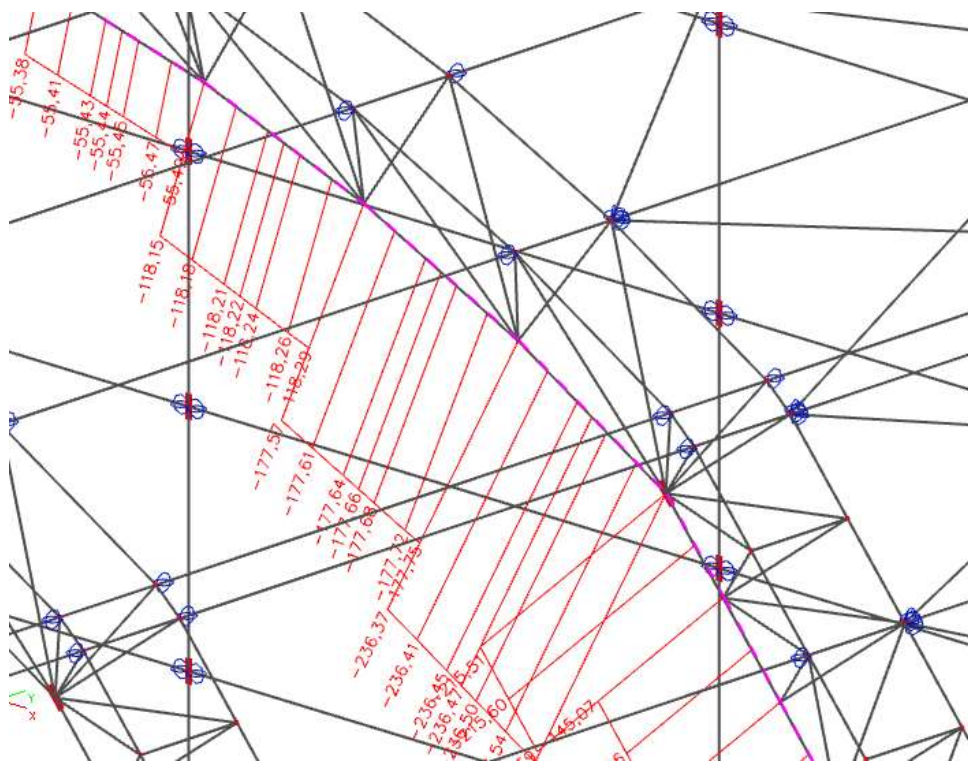

Figure 5.23. Axial force diagram (N)

Relevant combination: ULS4

$$\text{gsn4} / 1.35 \cdot \text{LC1} + 1.50 \cdot \text{snow} + 1.35 \cdot \text{constant load} + 1.05 \cdot \text{work+inst2}$$

$$N = -177,75 \text{ kN (compression)}$$

$$M_y = -0,28 \text{ kNm}$$

$$V_z = -0,21 \text{ kN}$$

$$M_z = 0,05 \text{ kNm}$$

$$V_y = 0,04 \text{ kN}$$

- Classification of gable column (CFCHS 139.7x4)

- Section in bending and/or compression

$$\frac{d}{t} \leq 50 \cdot \varepsilon^2$$

$$\frac{139,7}{4} = 34,85 \leq 42,32 \quad \text{class 1}$$

Cross section is in Class 1

1) Compression check

$$\frac{N_{Ed}}{N_{c,Rd}} \leq 1,0$$

$$N_{c,Rd} = \frac{A \cdot f_y}{\gamma_{M0}} = \frac{1,705 \cdot 10^{-3} \cdot 275 \cdot 10^3}{1,0} = 468,88 \text{ kN}$$

$$\frac{177,75}{468,88} = 0,38 < 1,0$$

2) Bending moment check for M_y

$$W_{pl,y} = 7,368 \cdot 10^{-5} \text{ m}^3$$

$$\frac{M_{Ed}}{M_{c,Rd}} \leq 1,0$$

$$M_{c,Rd} = M_{pl,Rd} = \frac{W_{pl,y} \cdot f_y}{\gamma_{M0}} = \frac{7,368 \cdot 10^{-5} \cdot 275 \cdot 10^3}{1,0} = 20,26 \text{ kN}$$

$$\frac{0,28}{20,26} = 0,01 < 1,0$$

3) Bending moment check for Mz

$$W_{pl,y} = 7,368 \cdot 10^{-5} m^3$$

$$\frac{M_{Ed}}{M_{c,Rd}} \leq 1,0$$

$$M_{c,Rd} = M_{pl,Rd} = \frac{W_{pl,y} \cdot f_y}{\gamma_{M0}} = \frac{7,368 \cdot 10^{-5} \cdot 275 \cdot 10^3}{1,0} = 20,26 kN$$

$$\frac{0,06}{20,26} = 0,0 < 1,0$$

4) Shear check for Vy

$$\frac{V_{Ed}}{V_{c,Rd}} \leq 1,0$$

$$V_{c,Rd} = V_{pl,Rd} = \frac{A_v \cdot f_y}{\gamma_{M0} \cdot \sqrt{3}}$$

⇒ A_v for circular hollow section is:

$$A_v = \frac{2 \cdot A}{\pi} = \frac{2 \cdot 1,705 \cdot 10^{-3}}{\pi} = 1,09 \cdot 10^{-3} m^2$$

$$V_{pl,Rd} = \frac{1,09 \cdot 10^{-3} \cdot 275 \cdot 10^3}{1,0 \cdot \sqrt{3}} = 173,06 kN$$

$$\frac{0,04}{173,06} = 0,0 < 1,0$$

5) Shear check for Vz

$$\frac{V_{Ed}}{V_{c,Rd}} \leq 1,0$$

$$V_{c,Rd} = V_{pl,Rd} = \frac{A_v \cdot f_y}{\gamma_{M0} \cdot \sqrt{3}}$$

⇒ A_v for circular hollow section is:

$$A_v = \frac{2 \cdot A}{\pi} = \frac{2 \cdot 1,705 \cdot 10^{-3}}{\pi} = 1,09 \cdot 10^{-3} \text{ m}^2$$

$$V_{pl,Rd} = \frac{1,09 \cdot 10^{-3} \cdot 275 \cdot 10^3}{1,0 \cdot \sqrt{3}} = 173,06 \text{ kN}$$

$$\frac{0,21}{173,06} = 0,0 < 1,0$$

6) Combined bending, axial force and shear force check

$$M_{Ed} \leq M_{N,Rd}$$

$V_{pl,Rd} = 173,06 \text{ kN}$; $V_{Ed} = 0,021$ → since the shear forces are less than half the plastic shear resistance their effect on the moment resistance is neglected

$$N_{pl,Rd} = \frac{A \cdot f_y}{\gamma_{M0}} = \frac{1,705 \cdot 10^{-3} \cdot 275 \cdot 10^3}{1,0} = 468,88 \text{ kN}$$

$$N_{Ed} = 175,75 \text{ kN}$$

$$n = \frac{N_{Ed}}{N_{pl,Rd}} = \frac{175,75}{468,88} = 0,37$$

$$M_{N,y,Rd} = M_{pl,y,Rd} \cdot \frac{1 - n}{1 - 0,5 \cdot a_w}$$

$$a_w = \frac{A - 2 \cdot b \cdot t}{A} = \frac{1,705 \cdot 10^{-3} - 2 \cdot 139,7 \cdot 10^{-3} \cdot 4 \cdot 10^{-3}}{1,705 \cdot 10^{-3}}$$

$$a_w = 0,34$$

$$M_{N,y,Rd} = 20,26 \cdot \frac{1 - 0,37}{1 - 0,5 \cdot 0,34}$$

$$M_{N,y,Rd} = 15,38 \text{ kNm}$$

$$\left[\frac{M_{y,Ed}}{M_{N,y,Rd}} \right]^\alpha + \left[\frac{M_{z,Ed}}{M_{N,z,Rd}} \right]^\beta$$

$\alpha = 2, \beta = 2$ → for circular hollow section

$$\left[\frac{0,28}{15,38}\right]^2 + \left[\frac{0,05}{15,38}\right]^2 \leq 1,0$$

$$0,0 \leq 1,0$$

7) Buckling of uniform members in compression

$$\frac{N_{Ed}}{N_{b,Rd}} \leq 1,0$$

$$N_{b,Rd} = \frac{\chi \cdot A \cdot f_y}{\gamma_{M0}}$$

$$\lambda_1 = 93,9 \cdot \varepsilon = 93,9 \cdot 0,92 = 86,39$$

Y	Z
$\lambda_{rel,0,y} = \frac{L_{cr,y}}{i_y} \cdot \frac{1}{\lambda_1} = \frac{2511}{48} \cdot \frac{1}{86,39}$	$\lambda_{rel,0,z} = \frac{L_{cr,z}}{i_z} \cdot \frac{1}{\lambda_1} = \frac{5022}{48} \cdot \frac{1}{86,39}$
$\lambda_{rel,0,y} = 0,61$	$\lambda_{rel,0,z} = 1,21$
$\chi_y = \frac{1}{\Phi_y + \sqrt{\Phi_y^2 - \lambda_{rel,0,y}^2}}$	$\chi_z = \frac{1}{\Phi_z + \sqrt{\Phi_z^2 - \lambda_{rel,0,z}^2}}$
$\Phi_y = 0,5(1 + \alpha(\lambda_{rel,0,y} - 0,2) + \lambda_{rel,0,y}^2)$	$\Phi_z = 0,5(1 + \alpha(\lambda_{rel,0,z} - 0,2) + \lambda_{rel,0,z}^2)$
Buckling curve	Buckling curve
y-y => c → $\alpha = 0,49$	z-z => c → $\alpha = 0,49$
$\Phi_y = 0,5(1 + 0,49(0,61 - 0,2) + 0,61^2)$	$\Phi_z = 0,5(1 + 0,49(1,21 - 0,2) + 1,21^2)$
$\Phi_y = 0,79$	$\Phi_z = 1,48$
$\chi_y = \frac{1}{0,79 + \sqrt{0,79^2 - 0,61^2}}$	$\chi_z = \frac{1}{1,48 + \sqrt{1,48^2 - 1,21^2}}$
$\chi_y = 0,77$	$\chi_z = 0,43$
$N_{b,Rd} = \frac{0,77 \cdot 1,705 \cdot 10^{-3} \cdot 275 \cdot 10^3}{1,0}$	$N_{b,Rd} = \frac{0,43 \cdot 1,705 \cdot 10^{-3} \cdot 275 \cdot 10^3}{1,0}$

$N_{b,Rd,y} = 361,03 \text{ kN}$	$N_{b,Rd,z} = 201,62 \text{ kN}$
----------------------------------	----------------------------------

$$\frac{175,75}{201,62} = 0,87 \leq 1,0$$

8) Uniform members in bending and axial compression

$$\frac{N_{Ed}}{\chi_y \cdot N_{Rk}} + k_{yy} \cdot \frac{M_{y,Ed}}{\chi_{LT} \cdot \frac{M_{y,Rk}}{\gamma_{M1}}} + k_{yz} \cdot \frac{M_{z,Ed}}{\frac{M_{z,Rk}}{\gamma_{M1}}} \leq 1,0 \quad (1)$$

$$\frac{N_{Ed}}{\chi_z \cdot N_{Rk}} + k_{zy} \cdot \frac{M_{y,Ed}}{\chi_{LT} \cdot \frac{M_{y,Rk}}{\gamma_{M1}}} + k_{zz} \cdot \frac{M_{z,Ed}}{\frac{M_{z,Rk}}{\gamma_{M1}}} \leq 1,0 \quad (2)$$

$$N_{Rk} = f_y \cdot A_i = 275 \cdot 10^3 \cdot 1,705 \cdot 10^{-3} = 468,88 \text{ kN}$$

$$M_{y,Rk} = f_y \cdot W_{pl,y} = 275 \cdot 10^3 \cdot 7,368 \cdot 10^{-5} = 20,26 \text{ kNm}$$

$$M_{z,Rk} = f_y \cdot W_{pl,z} = 20,26 \text{ kNm}$$

$$N_{Ed} = 175,75 \text{ kN}$$

$$M_{y,Ed} = -0,28 \text{ kNm}$$

$$M_{z,Ed} = 0,05 \text{ kNm}$$

$$\chi_y = 0,77$$

$$\lambda_{rel,0,y} = 0,61$$

$$\chi_z = 0,43$$

$$\lambda_{rel,0,z} = 1,21$$

$$\chi_{LT} = 1,0 \rightarrow \text{circular hollow section are not susceptible to torsional deformation}$$

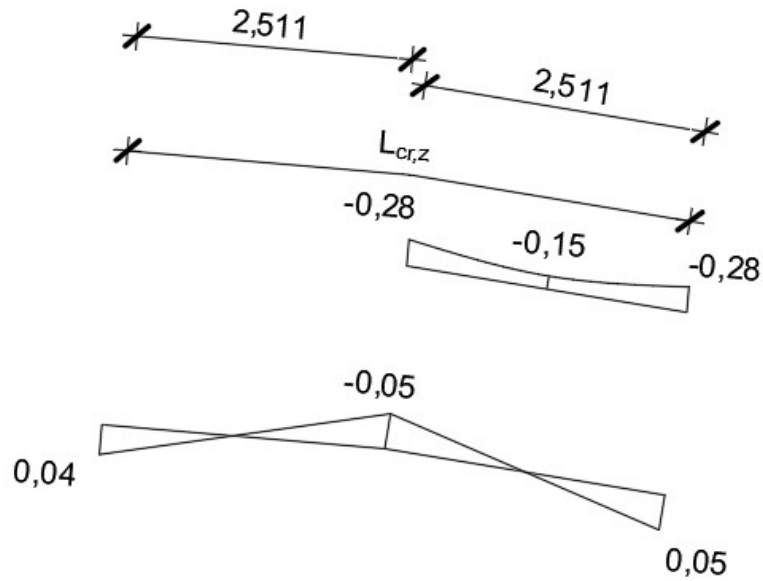

Figure 5.24. Bending moment diagrams for lower cord

$$k_{yy} \rightarrow C_{my} \rightarrow M_y \rightarrow L_{cr,y} \Rightarrow C_{my} = 0,2 + 0,8 \cdot \alpha_s = 0,2 + 0,8 \cdot 0,54 = 0,63 \geq 0,4$$

$$\alpha_s = \frac{-0,15}{-0,28} = 0,54$$

$$\psi = \frac{-0,28}{-0,28} = 1,0$$

$$C_{my} = 0,63$$

$$k_{zz} \rightarrow C_{mz} \rightarrow M_z \rightarrow L_{cr,z} \Rightarrow C_{mz} = -0,8 \cdot \alpha_s = -0,8 \cdot (-1,0) = 0,8 > 0,4$$

$$\psi = \frac{0,04}{0,05} = 0,80$$

$$\alpha_s = \frac{-0,05}{0,05} = -1,0$$

$$C_{mz} = 0,8$$

k_{yy}

$$C_{my} \left(1 + (\lambda_{rel,0,y} - 0,2) \cdot \frac{N_{Ed}}{\chi_y \cdot N_{Rk}} \right) \leq C_{my} \left(1 + 0,8 \cdot \frac{N_{Ed}}{\chi_y \cdot N_{Rk}} \right)$$

$$0,63 \cdot \left(1 + (0,61 - 0,2) \cdot \frac{175,75}{\frac{0,77 \cdot 468,88}{1,0}} \right) \leq 0,63 \cdot \left(1 + 0,8 \cdot \frac{175,75}{\frac{0,77 \cdot 468,88}{1,0}} \right)$$

$$0,76 \leq 0,80$$

k_{yz}

$$k_{yz} = 0,6 \cdot k_{zz} = 0,6 \cdot 1,36 = 0,82$$

k_{zy}

$$k_{zy} = 0,6 \cdot k_{yy} = 0,6 \cdot 0,76 = 0,46$$

k_{zz}

$$C_{mz} \left(1 + (\lambda_{rel,0,z} - 0,2) \cdot \frac{N_{Ed}}{\frac{\chi_z \cdot N_{Rk}}{\gamma_{M1}}} \right) \leq C_{mz} \left(1 + 0,8 \cdot \frac{N_{Ed}}{\frac{\chi_z \cdot N_{Rk}}{\gamma_{M1}}} \right)$$

$$0,8 \left(1 + (1,21 - 0,2) \cdot \frac{175,75}{\frac{0,43 \cdot 468,88}{1,0}} \right) \leq 0,8 \left(1 + 0,8 \cdot \frac{175,75}{\frac{0,43 \cdot 468,88}{1,0}} \right)$$

$$1,50 > 1,36$$

$$k_{yy} = 0,76$$

$$k_{yz} = 0,82$$

$$k_{zy} = 0,46$$

$$k_{zz} = 1,36$$

$$\frac{175,75}{\frac{0,77 \cdot 468,88}{1,0}} + 0,76 \cdot \frac{0,28}{1,0 \cdot \frac{20,26}{1,0}} + 0,82 \cdot \frac{0,05}{\frac{20,26}{1,0}} \leq 1,0 \quad (1)$$

$$\frac{175,75}{0,43 \cdot 468,88} + 0,46 \cdot \frac{0,28}{1,0 \cdot \frac{20,26}{1,0}} + 1,36 \cdot \frac{0,05}{\frac{20,26}{1,0}} \leq 1,0$$

(2)

$$0,50 \leq 1,0 \quad (1)$$

$$0,88 \leq 1,0 \quad (2)$$

5.5 Column grid (CFCHS 193.7x5)

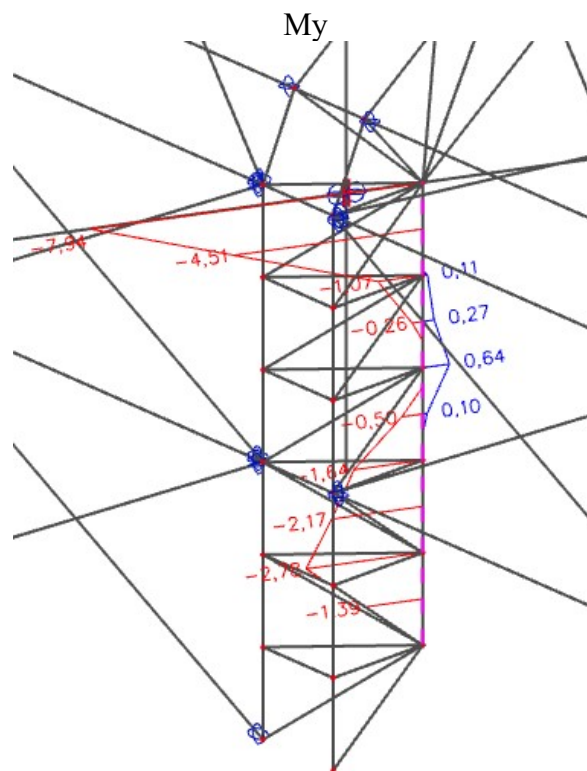

Figure 5.25. Bending moment diagram (My)

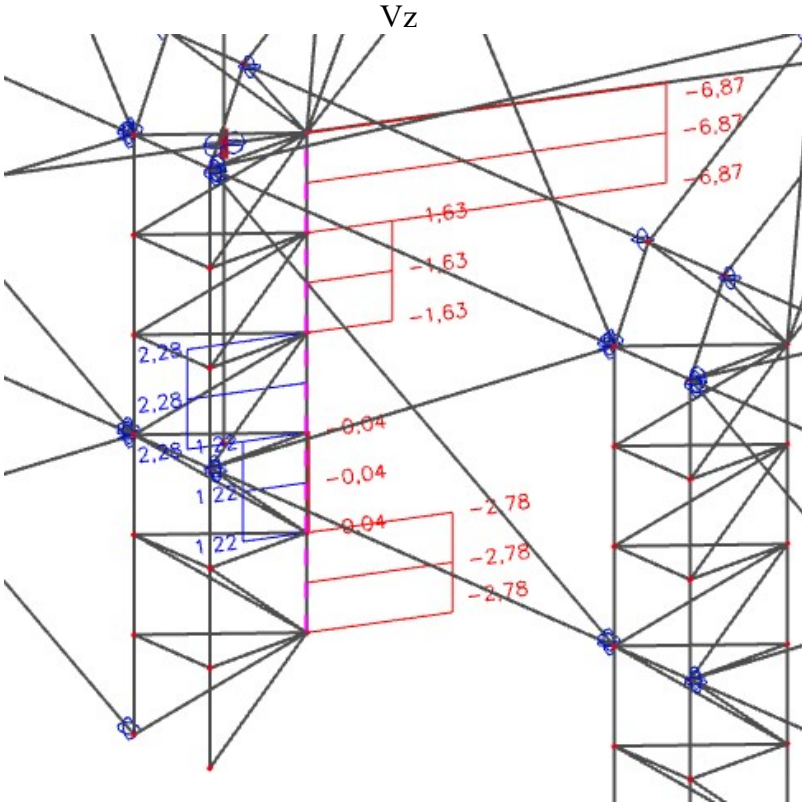

Figure 5.26. Shear force diagram (V_z)

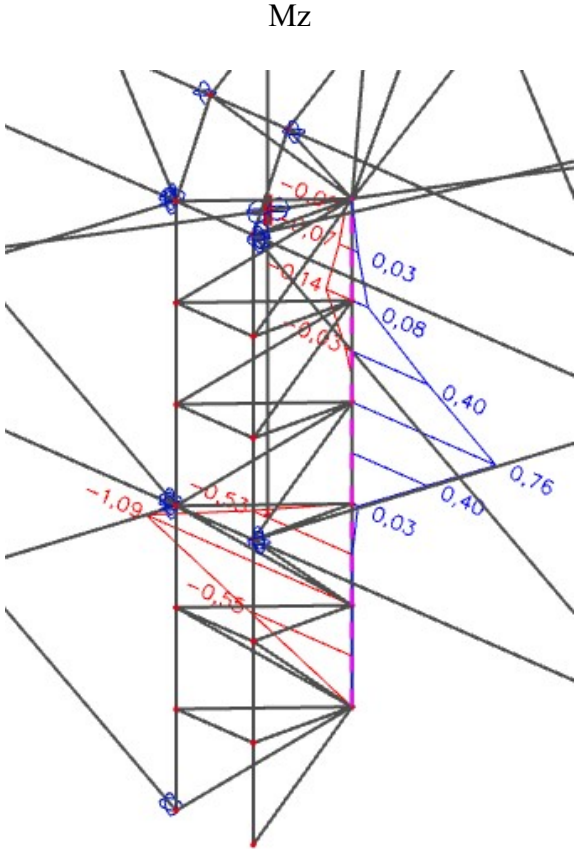

Figure 5.27. Bending moment diagram (M_z)

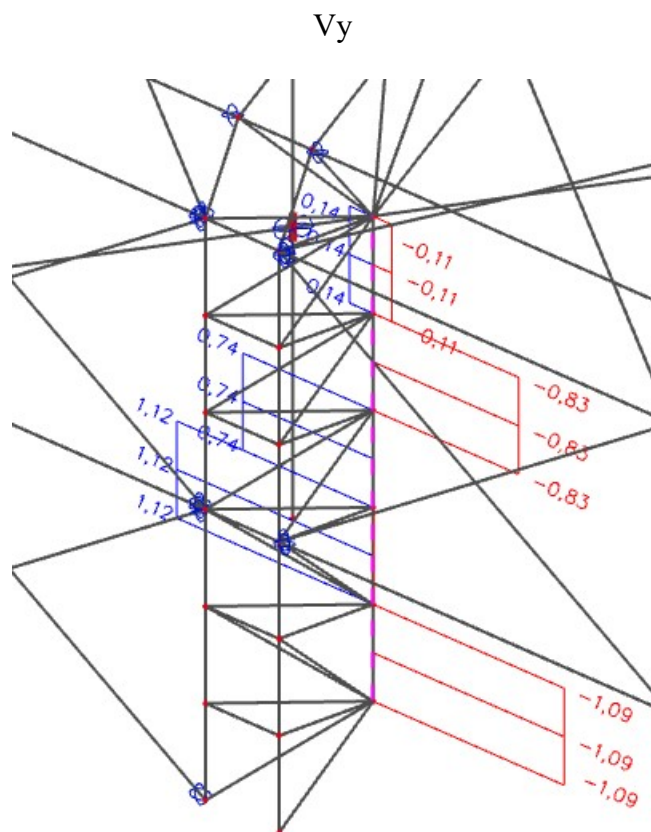

Figure 5.28. Shear force diagram (V_y)

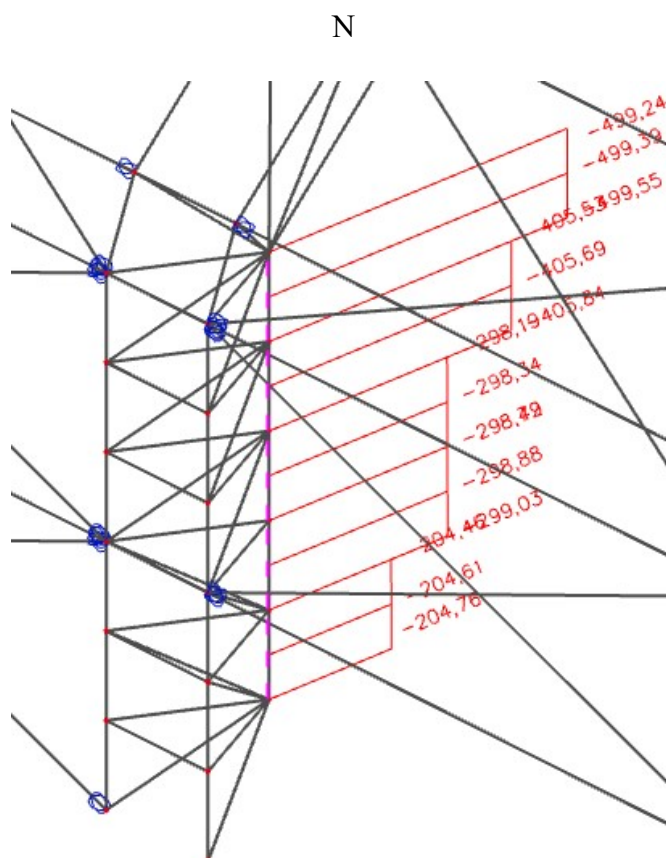

Figure 5.29. Axial force diagram (N)

Relevant combination: ULS14

gsn14 / 1.35*LC1 + 1.35*constant load + 1.05*work+inst1
+ 1.50*snow2 (2) + 0.90*temperature positive

$N = -499,55 \text{ kN}$ (compression)

$M_y = -1,07 \text{ kNm}$

$V_z = -6,87 \text{ kN}$

$M_z = -0,14 \text{ kNm}$

$V_y = 0,14 \text{ kN}$

- Classification of column grid(CFCHS 193.7x5)

- Section in bending and/or compression

$$\frac{d}{t} \leq 50 \cdot \varepsilon^2$$

$$\frac{193.7}{5} = 38,74 \leq 42,32 \quad \text{class 1}$$

Cross section is in Class 1

1) Compression check

$$\frac{N_{Ed}}{N_{c,Rd}} \leq 1,0$$

$$N_{c,Rd} = \frac{A \cdot f_y}{\gamma_{M0}} = \frac{2,964 \cdot 10^{-3} \cdot 275 \cdot 10^3}{1,0} = 815,1 \text{ kN}$$

$$\frac{499,55}{815,1} = 0,61 < 1,0$$

2) Bending moment check for M_y

$$W_{pl,y} = 1,7808 \cdot 10^{-4} \text{ m}^3$$

$$\frac{M_{Ed}}{M_{c,Rd}} \leq 1,0$$

$$M_{c,Rd} = M_{pl,Rd} = \frac{W_{pl,y} \cdot f_y}{\gamma_{M0}} = \frac{1,7808 \cdot 10^{-4} \cdot 275 \cdot 10^3}{1,0} = 48,97 \text{ kN}$$

$$\frac{1,07}{48,97} = 0,02 < 1,0$$

3) Bending moment check for Mz

$$W_{pl,y} = 1,7808 \cdot 10^{-4} \text{ m}^3$$

$$\frac{M_{Ed}}{M_{c,Rd}} \leq 1,0$$

$$M_{c,Rd} = M_{pl,Rd} = \frac{W_{pl,z} \cdot f_y}{\gamma_{M0}} = \frac{1,7808 \cdot 10^{-4} \cdot 275 \cdot 10^3}{1,0} = 48,97 \text{ kN}$$

$$\frac{0,14}{48,97} = 0,003 < 1,0$$

4) Shear check for Vy

$$\frac{V_{Ed}}{V_{c,Rd}} \leq 1,0$$

$$V_{c,Rd} = V_{pl,Rd} = \frac{A_v \cdot f_y}{\gamma_{M0} \cdot \sqrt{3}}$$

⇒ A_v for circular hollow section is:

$$A_v = \frac{2 \cdot A}{\pi} = \frac{2 \cdot 2,964 \cdot 10^{-3}}{\pi} = 1,8869 \cdot 10^{-3} \text{ m}^2$$

$$V_{pl,Rd} = \frac{1,8869 \cdot 10^{-3} \cdot 275 \cdot 10^3}{1,0 \cdot \sqrt{3}} = 299,59 \text{ kN}$$

$$\frac{0,14}{299,59} = 0,0 < 1,0$$

5) Shear check for Vz

$$\frac{V_{Ed}}{V_{c,Rd}} \leq 1,0$$

$$V_{c,Rd} = V_{pl,Rd} = \frac{A_v \cdot f_y}{\gamma_{M0} \cdot \sqrt{3}}$$

⇒ A_v for circular hollow section is:

$$A_v = \frac{2 \cdot A}{\pi} = \frac{2 \cdot 2,964 \cdot 10^{-3}}{\pi} = 1,8869 \cdot 10^{-3} \text{ m}^2$$

$$V_{pl,Rd} = \frac{1,8869 \cdot 10^{-3} \cdot 275 \cdot 10^3}{1,0 \cdot \sqrt{3}} = 299,59 \text{ kN}$$

$$\frac{6,87}{299,59} = 0,02 < 1,0$$

6) Combined bending, axial force and shear force check

$$M_{Ed} \leq M_{N,Rd}$$

$V_{pl,Rd} = 299,59 \text{ kN}$; $V_{Ed} = 0,38$ → since the shear forces are less than half the plastic shear resistance their effect on the moment resistance is neglected

$$N_{pl,Rd} = \frac{A \cdot f_y}{\gamma_{M0}} = \frac{2,964 \cdot 10^{-3} \cdot 275 \cdot 10^3}{1,0} = 815,1 \text{ kN}$$

$$N_{Ed} = 499,55 \text{ kN}$$

$$n = \frac{N_{Ed}}{N_{pl,Rd}} = \frac{499,55}{815,1} = 0,61$$

$$M_{N,y,Rd} = M_{pl,y,Rd} \cdot \frac{1 - n}{1 - 0,5 \cdot a_w}$$

$$a_w = \frac{A - 2 \cdot b \cdot t}{A} = \frac{2,964 \cdot 10^{-3} - 2 \cdot 193,7 \cdot 10^{-3} \cdot 5 \cdot 10^{-3}}{2,964 \cdot 10^{-3}}$$

$$a_w = 0,35$$

$$M_{N,y,Rd} = 48,97 \cdot \frac{1 - 0,61}{1 - 0,5 \cdot 0,35}$$

$$M_{N,y,Rd} = 23,15 \text{ kNm}$$

$$\left[\frac{M_{y,Ed}}{M_{N,y,Rd}} \right]^\alpha + \left[\frac{M_{z,Ed}}{M_{N,z,Rd}} \right]^\beta$$

$\alpha = 2, \beta = 2 \rightarrow$ for circular hollow section

$$\left[\frac{1,07}{23,15} \right]^2 + \left[\frac{0,14}{23,15} \right]^2 \leq 1,0$$

$$0,001 \leq 1,0$$

7) Buckling of uniform members in compression

$$\frac{N_{Ed}}{N_{b,Rd}} \leq 1,0$$

$$N_{b,Rd} = \frac{\chi \cdot A \cdot f_y}{\gamma_{M0}}$$

$$\lambda_1 = 93,9 \cdot \varepsilon = 93,9 \cdot 0,92 = 86,39$$

Y	Z
$\lambda_{rel,0,y} = \frac{L_{cr,y}}{i_y} \cdot \frac{1}{\lambda_1} = \frac{1000}{67} \cdot \frac{1}{86,39}$ $\lambda_{rel,0,y} = \mathbf{0,17} < \mathbf{0,2}$	$\lambda_{rel,0,z} = \frac{L_{cr,z}}{i_z} \cdot \frac{1}{\lambda_1} = \frac{3000}{67} \cdot \frac{1}{86,39}$ $\lambda_{rel,0,z} = \mathbf{0,52}$
$\chi_y = \mathbf{1,0}$	$\chi_z = \frac{1}{\Phi_z + \sqrt{\Phi_z^2 - \lambda_{rel,0,z}^2}}$
$N_{b,Rd} = \frac{1,0 \cdot 2,964 \cdot 10^{-3} \cdot 275 \cdot 10^3}{1,0}$ $N_{b,Rd,y} = 815,1 \text{ kN}$	$\Phi_z = 0,5(1 + \alpha(\lambda_{rel,0,z} - 0,2) + \lambda_{rel,0,z}^2)$ <p>Buckling curve</p> <p>z-z => c $\rightarrow \alpha = 0,49$</p> $\Phi_z = 0,5(1 + 0,49(0,52 - 0,2) + 0,52^2)$ $\Phi_z = \mathbf{0,71}$
	$\chi_z = \frac{1}{0,71 + \sqrt{0,71^2 - 0,52^2}}$

	$\chi_z = 0,84$ $N_{b,Rd} = \frac{0,84 \cdot 2,964 \cdot 10^{-3} \cdot 275 \cdot 10^3}{1,0}$ $N_{b,Rd,z} = 684,68 \text{ kN}$
--	---

$$\frac{499,55}{684,68} = 0,73 \leq 1,0$$

8) Uniform members in bending and axial compression

$$\frac{N_{Ed}}{\chi_y \cdot N_{Rk}} + k_{yy} \cdot \frac{M_{y,Ed}}{\chi_{LT} \cdot \frac{M_{y,Rk}}{\gamma_{M1}}} + k_{yz} \cdot \frac{M_{z,Ed}}{\frac{M_{z,Rk}}{\gamma_{M1}}} \leq 1,0 \quad (1)$$

$$\frac{N_{Ed}}{\chi_z \cdot N_{Rk}} + k_{zy} \cdot \frac{M_{y,Ed}}{\chi_{LT} \cdot \frac{M_{y,Rk}}{\gamma_{M1}}} + k_{zz} \cdot \frac{M_{z,Ed}}{\frac{M_{z,Rk}}{\gamma_{M1}}} \leq 1,0 \quad (2)$$

$$N_{Rk} = f_y \cdot A_i = 275 \cdot 10^3 \cdot 2,964 \cdot 10^{-3} = 815,1 \text{ kN}$$

$$M_{y,Rk} = f_y \cdot W_{pl,y} = 275 \cdot 10^3 \cdot 1,7808 \cdot 10^{-4} = 48,97 \text{ kNm}$$

$$M_{z,Rk} = f_y \cdot W_{pl,z} = 48,97 \text{ kNm}$$

$$N_{Ed} = 499,55 \text{ kN}$$

$$M_{y,Ed} = -7,94 \text{ kNm}$$

$$M_{z,Ed} = 0,76 \text{ kNm}$$

$$\chi_y = 1,0$$

$$\lambda_{rel,0,y} = 0,17$$

$$\chi_z = 0,84$$

$$\lambda_{rel,0,z} = 0,52$$

$$\chi_{LT} = 1,0 \rightarrow \text{circular hollow section are not susceptible to torsional deformation}$$

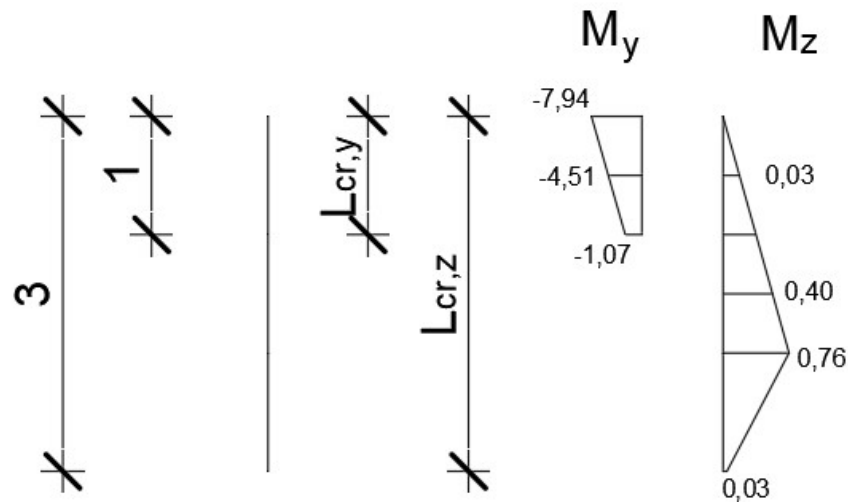

Figure 5.30. Bending moment diagrams for column grid

$$k_{yy} \rightarrow C_{my} \rightarrow M_y \rightarrow L_{cr,y} \Rightarrow C_{my} = 0,6 + 0,4 \cdot \alpha_s = 0,6 + 0,4 \cdot 0,13 = 0,65 \geq 0,4$$

$$\psi = \frac{-1,07}{-7,94} = 0,13$$

$$C_{my} = 0,65$$

$$k_{zz} \rightarrow C_{mz} \rightarrow M_z \rightarrow L_{cr,z} \Rightarrow C_{mz} = 0,9 + 0,1 \cdot \alpha_h = 0,9 + 0,1 \cdot 0,04 = 0,9$$

$$\psi = 0$$

$$\alpha_h = \frac{0,03}{0,76} = 0,04$$

$$C_{mz} = 0,9$$

k_{yy}

$$C_{my} \left(1 + (\lambda_{rel,0,y} - 0,2) \cdot \frac{N_{Ed}}{\frac{\chi_y \cdot N_{Rk}}{\gamma_{M1}}} \right) \leq C_{my} \left(1 + 0,8 \cdot \frac{N_{Ed}}{\frac{\chi_y \cdot N_{Rk}}{\gamma_{M1}}} \right)$$

$$0,65 \cdot \left(1 + (0,17 - 0,2) \cdot \frac{499,95}{\frac{1,0 \cdot 815,1}{1,0}} \right) \leq 0,65 \cdot \left(1 + 0,8 \cdot \frac{499,95}{\frac{1,0 \cdot 815,1}{1,0}} \right)$$

$$0,64 \leq 0,97$$

$$k_{yy} = 0,64$$

$$\mathbf{k}_{yz}$$

$$k_{yz} = 0,6 \cdot k_{zz} = 0,6 \cdot 1,11 = 0,67$$

$$\mathbf{k}_{zy}$$

$$k_{zy} = 0,6 \cdot k_{yy} = 0,6 \cdot 0,64 = 0,38$$

$$\mathbf{k}_{zz}$$

$$C_{mz} \left(1 + (\lambda_{rel,0,z} - 0,2) \cdot \frac{N_{Ed}}{\frac{\chi_z \cdot N_{Rk}}{\gamma_{M1}}} \right) \leq C_{mz} \left(1 + 0,8 \cdot \frac{N_{Ed}}{\frac{\chi_z \cdot N_{Rk}}{\gamma_{M1}}} \right)$$

$$0,9 \left(1 + (0,52 - 0,2) \cdot \frac{499,95}{\frac{0,84 \cdot 815,1}{1,0}} \right) \leq 0,9 \left(1 + 0,8 \cdot \frac{499,95}{\frac{0,84 \cdot 815,1}{1,0}} \right)$$

$$1,11 < 1,43$$

$$k_{yy} = 0,64$$

$$k_{yz} = 0,67$$

$$k_{zy} = 0,38$$

$$k_{zz} = 1,11$$

$$\frac{499,95}{\frac{1,0 \cdot 815,1}{1,0}} + 0,64 \cdot \frac{7,94}{1,0 \cdot \frac{48,97}{1,0}} + 0,67 \cdot \frac{0,76}{\frac{48,97}{1,0}} \leq 1,0 \quad (1)$$

$$\frac{499,95}{\frac{0,84 \cdot 815,1}{1,0}} + 0,38 \cdot \frac{7,94}{1,0 \cdot \frac{48,97}{1,0}} + 1,11 \cdot \frac{0,76}{\frac{48,97}{1,0}} \leq 1,0 \quad (2)$$

$$0,73 \leq 1,0 \quad (1)$$

$$0,81 \leq 1,0 \quad (2)$$

5.6 Horizontal cord (CFCHS 60.3x5)

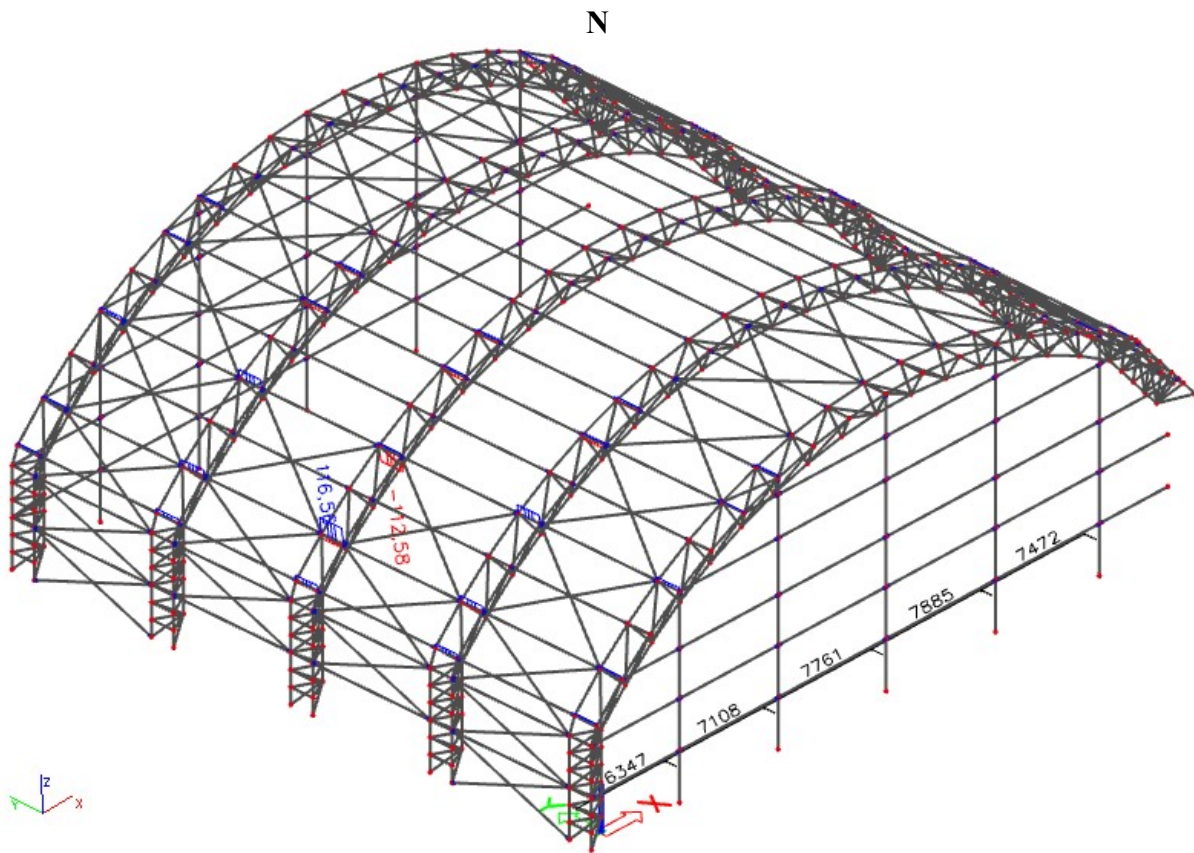

Figure 5.31. Axial force diagram (N)

Relevant combination: ULS11

`gsn11 / 1.35*LC1 + 1.50*snow2 (1) + 1.35*constant load
+ 1.05*work+inst3`

$N = -112,58 \text{ kN}$ (compression)

$M_y = 0 \text{ kNm}$

$V_z = -0 \text{ kN}$

$M_z = 0 \text{ kNm}$

$V_y = 0 \text{ kN}$

- Classification of gable column (CFCHS 60.3x5)

- Section in bending and/or compression

$$\frac{d}{t} \leq 50 \cdot \varepsilon^2$$

$$\frac{60,3}{5} = 12,06 \leq 42,32 \quad \text{class 1}$$

Cross section is in Class 1

1) Compression check

$$\frac{N_{Ed}}{N_{c,Rd}} \leq 1,0$$

$$N_{c,Rd} = \frac{A \cdot f_y}{\gamma_{M0}} = \frac{8,69 \cdot 10^{-4} \cdot 275 \cdot 10^3}{1,0} = 238,98 \text{ kN}$$

$$\frac{112,58}{238,98} = 0,47 < 1,0$$

1) Buckling of uniform members in compression

$$\frac{N_{Ed}}{N_{b,Rd}} \leq 1,0$$

$$N_{b,Rd} = \frac{\chi \cdot A \cdot f_y}{\gamma_{M0}}$$

$$\lambda_1 = 93,9 \cdot \varepsilon = 93,9 \cdot 0,92 = 86,39$$

Y

$$\lambda_{rel,0,y} = \frac{L_{cr,y}}{i_y} \cdot \frac{1}{\lambda_1} = \frac{1500}{20} \cdot \frac{1}{86,39}$$

$$\lambda_{rel,0,y} = \mathbf{0,87}$$

$$\chi_y = \frac{1}{\Phi_y + \sqrt{\Phi_y^2 - \lambda_{rel,0,y}^2}}$$

$$\Phi_y = 0,5(1 + \alpha(\lambda_{rel,0,y} - 0,2) + \lambda_{rel,0,y}^2)$$

Buckling curve

y-y => c → $\alpha = 0,49$

$$\Phi_y = 0,5(1 + 0,49(0,87 - 0,2) + 0,87^2)$$

$$\Phi_y = 1,043$$

$$\chi_y = \frac{1}{1,043 + \sqrt{1,043^2 - 0,87^2}}$$

$$\chi_y = 0,62$$

$$N_{b,Rd} = \frac{0,62 \cdot 0,869 \cdot 10^{-3} \cdot 275 \cdot 10^3}{1,0}$$

$$N_{b,Rd,y} = 148,16 \text{ kN}$$

$$\frac{112,58}{148,16} = 0,76 \leq 1,0$$

5.7 Horizontal grid 2 (CFCHS 76.1x5)

N

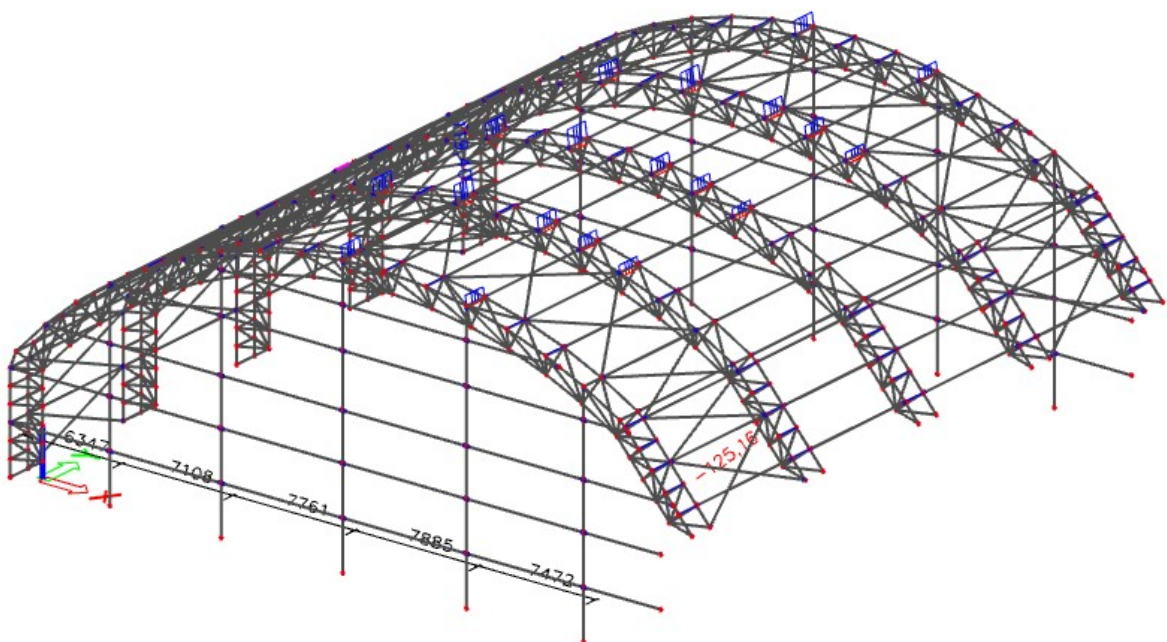

Figure 5.32. Axial force diagram (N)

Relevant combination: ULS46 uplift

gsn46 uplift / LC1 + 1.50*wind -0.3 + constant load +
0.90*temperature positive

$N = -125,16 \text{ kN}$ (compression)

$M_y = 0 \text{ kNm}$

$V_z = 0 \text{ kN}$

$M_z = 0 \text{ kNm}$

$V_y = 0 \text{ kN}$

- Classification of gable column (CFCHS 76.1x5)

- Section in bending and/or compression

$$\frac{d}{t} \leq 50 \cdot \varepsilon^2$$

$$\frac{76,1}{5} = 15,22 \leq 42,32 \quad \text{class 1}$$

Cross section is in Class 1

2) Compression check

$$\frac{N_{Ed}}{N_{c,Rd}} \leq 1,0$$

$$N_{c,Rd} = \frac{A \cdot f_y}{\gamma_{M0}} = \frac{1,1170 \cdot 10^{-3} \cdot 275 \cdot 10^3}{1,0} = 307,18 \text{ kN}$$

$$\frac{125,16}{307,18} = 0,41 < 1,0$$

2) Buckling of uniform members in compression

$$\frac{N_{Ed}}{N_{b,Rd}} \leq 1,0$$

$$N_{b,Rd} = \frac{\chi \cdot A \cdot f_y}{\gamma_{M0}}$$

$$\lambda_1 = 93,9 \cdot \varepsilon = 93,9 \cdot 0,92 = 86,39$$

Y

$$\lambda_{rel,0,y} = \frac{L_{cr,y}}{i_y} \cdot \frac{1}{\lambda_1} = \frac{1500}{25} \cdot \frac{1}{86,39}$$

$$\lambda_{rel,0,y} = \mathbf{0,69}$$

$$\chi_y = \frac{1}{\Phi_y + \sqrt{\Phi_y^2 - \lambda_{rel,0,y}^2}}$$

$$\Phi_y = 0,5(1 + \alpha(\lambda_{rel,0,y} - 0,2) + \lambda_{rel,0,y}^2)$$

Buckling curve

$$y-y \Rightarrow c \rightarrow \alpha = 0,49$$

$$\Phi_y = 0,5(1 + 0,49(0,69 - 0,2) + 0,69^2)$$

$$\Phi_y = 0,86$$

$$\chi_y = \frac{1}{0,86 + \sqrt{0,86^2 - 0,69^2}}$$

$$\chi_y = \mathbf{0,73}$$

$$N_{b,Rd} = \frac{0,73 \cdot 1,117 \cdot 10^{-3} \cdot 275 \cdot 10^3}{1,0}$$

$$N_{b,Rd,y} = 224,24 \text{ kN}$$

$$\frac{125,16}{224,24} = 0,56 \leq 1,0$$

5.8 Vertikal cord (CFCHS 60.3x3)

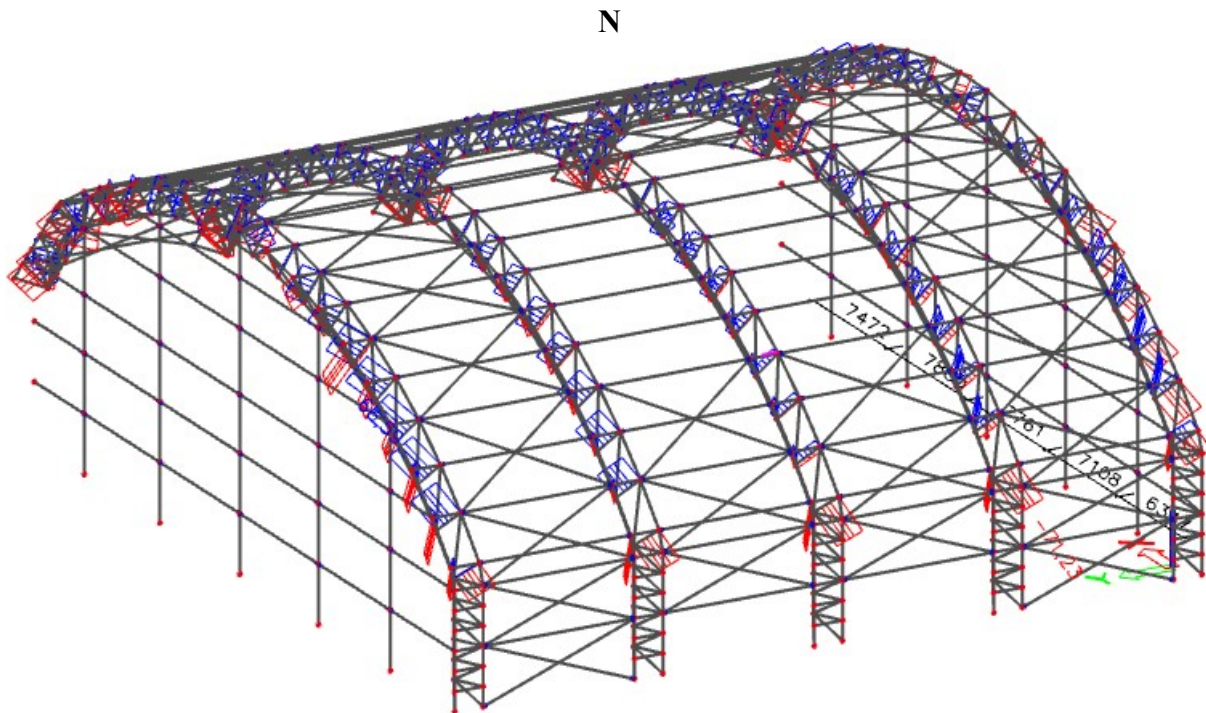

Figure 5.33. Axial force diagram (N)

Relevant combination: ULS4

gsn4 / 1.35*LC1 + 1.50*snow + 1.35*constant load +
1.05*work+inst2

$N = -71,23 \text{ kN}$ (compression)

$M_y = 0 \text{ kNm}$

$V_z = -0 \text{ kN}$

$M_z = 0 \text{ kNm}$

$V_y = 0 \text{ kN}$

- Classification of gable column (CFCHS 60.3x3)

- Section in bending and/or compression

$$\frac{d}{t} \leq 50 \cdot \varepsilon^2$$

$$\frac{60,3}{3} = 20,1 \leq 42,32 \quad \text{class 1}$$

Cross section is in Class 1

3) Compression check

$$\frac{N_{Ed}}{N_{c,Rd}} \leq 1,0$$

$$N_{c,Rd} = \frac{A \cdot f_y}{\gamma_{M0}} = \frac{5,4 \cdot 10^{-4} \cdot 275 \cdot 10^3}{1,0} = 148,5 \text{ kN}$$

$$\frac{71,23}{148,5} = 0,48 < 1,0$$

3) Buckling of uniform members in compression

$$\frac{N_{Ed}}{N_{b,Rd}} \leq 1,0$$

$$N_{b,Rd} = \frac{\chi \cdot A \cdot f_y}{\gamma_{M0}}$$

$$\lambda_1 = 93,9 \cdot \varepsilon = 93,9 \cdot 0,92 = 86,39$$

Y

$$\lambda_{rel,0,y} = \frac{L_{cr,y}}{i_y} \cdot \frac{1}{\lambda_1} = \frac{1677}{20} \cdot \frac{1}{86,39}$$

$$\lambda_{rel,0,y} = 0,97$$

$$\chi_y = \frac{1}{\Phi_y + \sqrt{\Phi_y^2 - \lambda_{rel,0,y}^2}}$$

$$\Phi_y = 0,5(1 + \alpha(\lambda_{rel,0,y} - 0,2) + \lambda_{rel,0,y}^2)$$

Buckling curve

$$y-y \Rightarrow c \rightarrow \alpha = 0,49$$

$$\Phi_y = 0,5(1 + 0,49(0,97 - 0,2) + 0,97^2)$$

$$\Phi_y = 1,16$$

$$\chi_y = \frac{1}{1,16 + \sqrt{1,16^2 - 0,97^2}}$$

$$\chi_y = 0,56$$

$$N_{b,Rd} = \frac{0,56 \cdot 0,54 \cdot 10^{-3} \cdot 275 \cdot 10^3}{1,0}$$

$$N_{b,Rd,y} = 83,16 \text{ kN}$$

$$\frac{71,23}{83,16} = 0,86 \leq 1,0$$

5.9 diagonal cord (CFCHS 88.9x6)

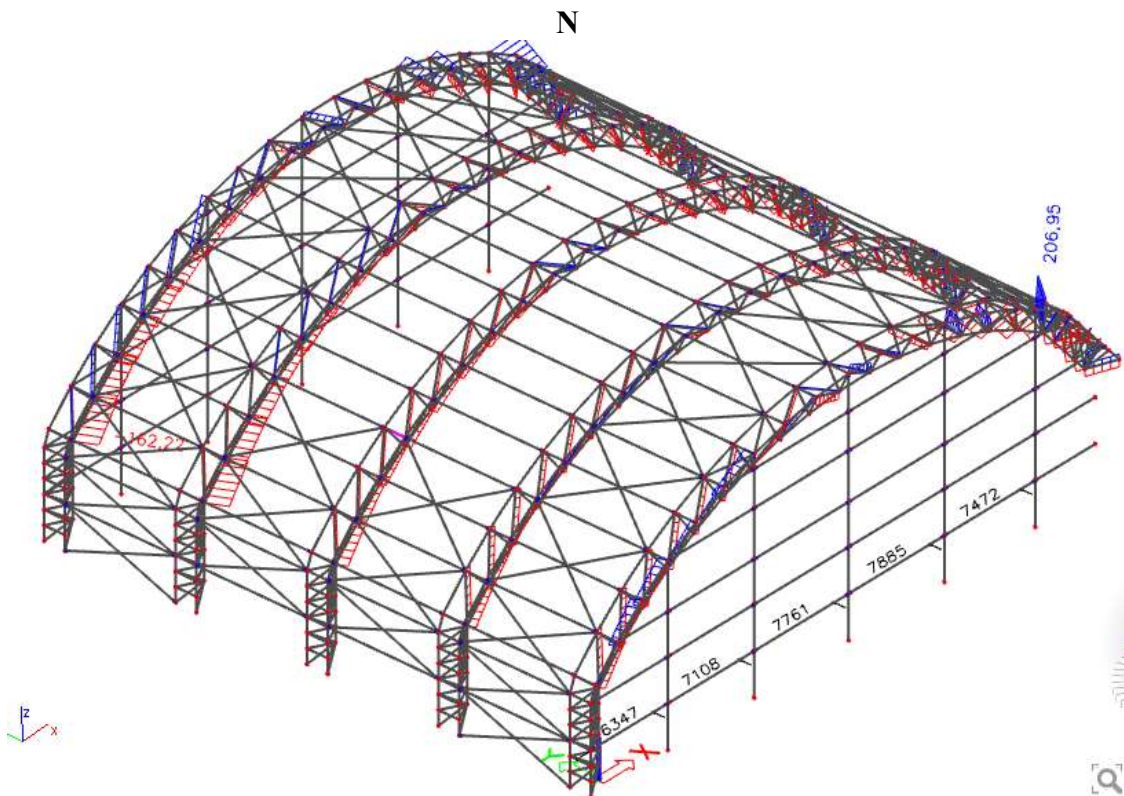

Figure 5.34. Axial force diagram (N)

Relevant combination: ULS37

$$\text{gsn37} / 1.35 \cdot \text{LC1} + 1.50 \cdot \text{snow} + 1.35 \cdot \text{constant load} + 1.05 \cdot \text{work+inst1}$$

$$N = -162,22 \text{ kN (compression)}$$

$$M_y = 0 \text{ kNm}$$

$$V_z = -0 \text{ kN}$$

$$M_z = 0 \text{ kNm}$$

$$V_y = 0 \text{ kN}$$

- Classification of gable column (CFCHS 88.9x6)

- Section in bending and/or compression

$$\frac{d}{t} \leq 50 \cdot \varepsilon^2$$

$$\frac{88,9}{6} = 14,81 \leq 42,32 \quad \text{class 1}$$

Cross section is in Class 1

4) Compression check

$$\frac{N_{Ed}}{N_{c,Rd}} \leq 1,0$$

$$N_{c,Rd} = \frac{A \cdot f_y}{\gamma_{M0}} = \frac{1,563 \cdot 10^{-3} \cdot 275 \cdot 10^3}{1,0} = 429,83 \text{ kN}$$

$$\frac{162,22}{429,83} = 0,38 < 1,0$$

4) Buckling of uniform members in compression

$$\frac{N_{Ed}}{N_{b,Rd}} \leq 1,0$$

$$N_{b,Rd} = \frac{\chi \cdot A \cdot f_y}{\gamma_{M0}}$$

$$\lambda_1 = 93,9 \cdot \varepsilon = 93,9 \cdot 0,92 = 86,39$$

Y

$$\lambda_{rel,0,y} = \frac{L_{cr,y}}{i_y} \cdot \frac{1}{\lambda_1} = \frac{3073}{29} \cdot \frac{1}{86,39}$$

$$\lambda_{rel,0,y} = \mathbf{1,23}$$

$$\chi_y = \frac{1}{\Phi_y + \sqrt{\Phi_y^2 - \lambda_{rel,0,y}^2}}$$

$$\Phi_y = 0,5(1 + \alpha(\lambda_{rel,0,y} - 0,2) + \lambda_{rel,0,y}^2)$$

Buckling curve

$$y-y \Rightarrow c \rightarrow \alpha = 0,49$$

$$\Phi_y = 0,5(1 + 0,49(1,23 - 0,2) + 1,23^2)$$

$$\Phi_y = 1,51$$

$$\chi_y = \frac{1}{1,51 + \sqrt{1,51^2 - 1,23^2}}$$

$$\chi_y = \mathbf{0,42}$$

$$N_{b,Rd} = \frac{0,42 \cdot 1,563 \cdot 10^{-3} \cdot 275 \cdot 10^3}{1,0}$$

$$N_{b,Rd,y} = 180,53 \text{ kN}$$

$$\frac{162,22}{180,53} = 0,90 \leq 1,0$$

5.10 diagonal of upper cord (CFCHS 101.6x5)

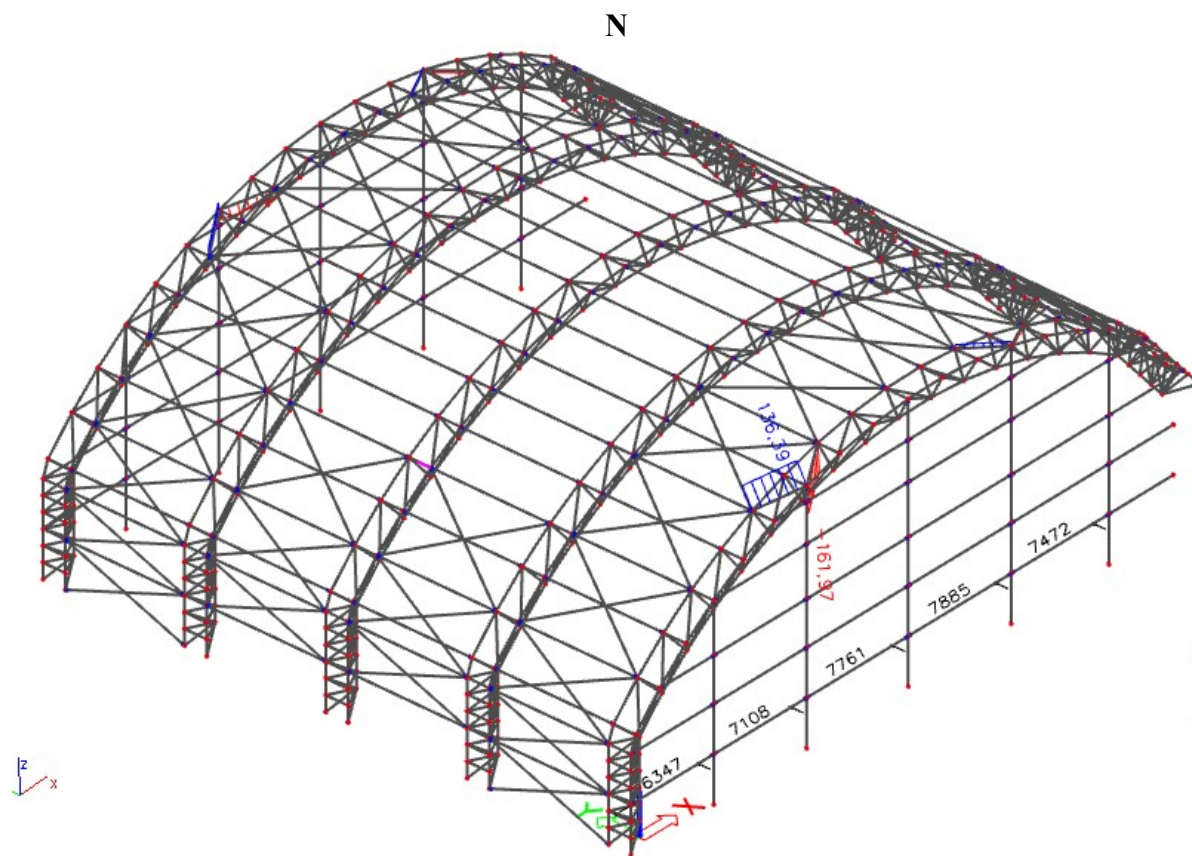

Figure 5.35. Axial force diagram (N)

Relevant combination: ULS38

gsn38 / 1.35*LC1 + 1.50*snow + 1.35*constant load +
1.05*work+inst2

$N = -161,97 \text{ kN}$ (compression)

$M_y = 0 \text{ kNm}$

$V_z = -0 \text{ kN}$

$M_z = 0 \text{ kNm}$

$V_y = 0 \text{ kN}$

- Classification of gable column (CFCHS 101.6x5)

- Section in bending and/or compression

$$\frac{d}{t} \leq 50 \cdot \varepsilon^2$$

$$\frac{101.6}{5} = 20,32 \leq 42,32 \quad \text{class 1}$$

Cross section is in Class 1

5) Compression check

$$\frac{N_{Ed}}{N_{c,Rd}} \leq 1,0$$

$$N_{c,Rd} = \frac{A \cdot f_y}{\gamma_{M0}} = \frac{1,517 \cdot 10^{-3} \cdot 275 \cdot 10^3}{1,0} = 417,18N$$

$$\frac{161,97}{417,18} = 0,39 < 1,0$$

5) Buckling of uniform members in compression

$$\frac{N_{Ed}}{N_{b,Rd}} \leq 1,0$$

$$N_{b,Rd} = \frac{\chi \cdot A \cdot f_y}{\gamma_{M0}}$$

$$\lambda_1 = 93,9 \cdot \varepsilon = 93,9 \cdot 0,92 = 86,39$$

Y

$$\lambda_{rel,0,y} = \frac{L_{cr,y}}{i_y} \cdot \frac{1}{\lambda_1} = \frac{3038}{34} \cdot \frac{1}{86,39}$$

$$\lambda_{rel,0,y} = 1,03$$

$$\chi_y = \frac{1}{\Phi_y + \sqrt{\Phi_y^2 - \lambda_{rel,0,y}^2}}$$

$$\Phi_y = 0,5(1 + \alpha(\lambda_{rel,0,y} - 0,2) + \lambda_{rel,0,y}^2)$$

Buckling curve

$$y-y \Rightarrow c \rightarrow \alpha = 0,49$$

$$\Phi_y = 0,5(1 + 0,49(1,03 - 0,2) + 1,03^2)$$

$$\Phi_y = 1,23$$

$$\chi_y = \frac{1}{1,23 + \sqrt{1,23^2 - 1,03^2}}$$

$$\chi_y = 0,53$$

$$N_{b,Rd} = \frac{0,53 \cdot 1,517 \cdot 10^{-3} \cdot 275 \cdot 10^3}{1,0}$$

$$N_{b,Rd,y} = 221,10 \text{ kN}$$

$$\frac{161,97}{221,10} = 0,73 \leq 1,0$$

5.11 Inside bars of column (CFCHS 88.9x5)

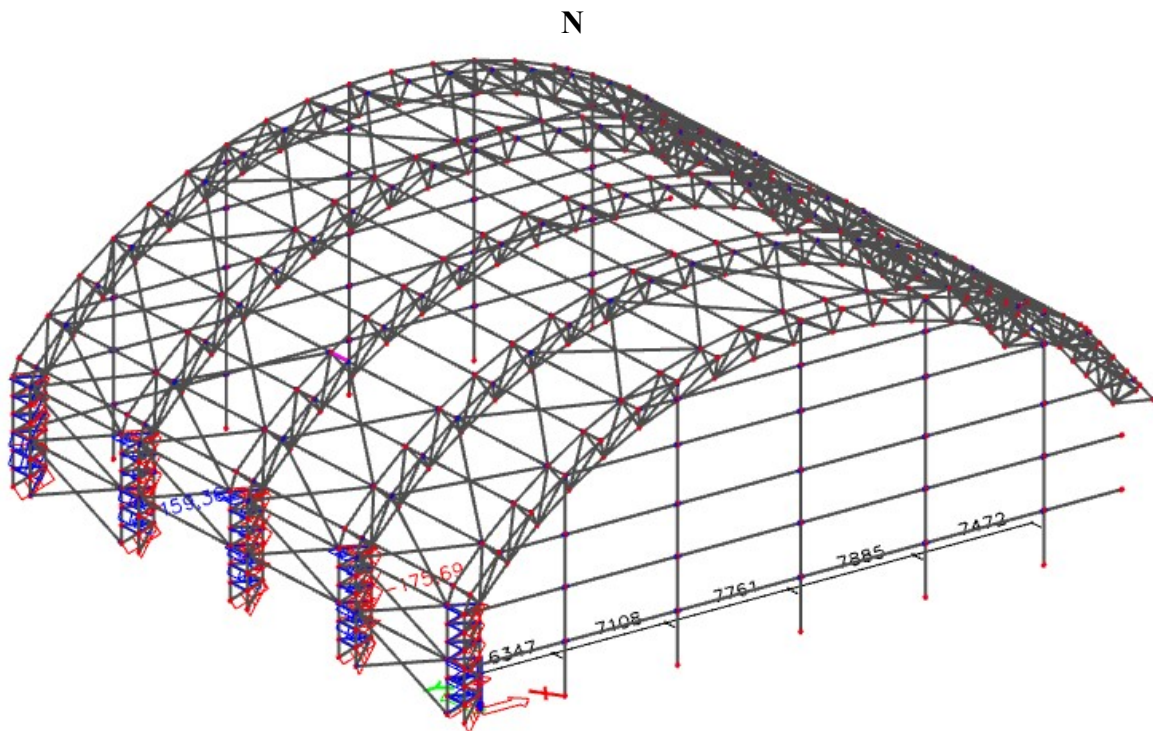

Figure 5.36. Axial force diagram (N)

Relevant combination: ULS14

$$\underline{\text{gsn14} / 1.35 \cdot \text{LC1} + 0.90 \cdot \text{wind} - 0.3 + 1.35 \cdot \text{constant load} + 1.05 \cdot \text{work+inst1} + 0.90 \cdot \text{temperature positive}}$$

$$N = -175,69 \text{ kN (compression)}$$

$$M_y = 0 \text{ kNm}$$

$$V_z = -0 \text{ kN}$$

$$M_z = 0 \text{ kNm}$$

$$V_y = 0 \text{ kN}$$

- Classification of gable column (CFCHS 88.9x5)

- Section in bending and/or compression

$$\frac{d}{t} \leq 50 \cdot \varepsilon^2$$

$$\frac{88,9}{5} = 17,78 \leq 42,32 \quad \text{class 1}$$

Cross section is in Class 1

6) Compression check

$$\frac{N_{Ed}}{N_{c,Rd}} \leq 1,0$$

$$N_{c,Rd} = \frac{A \cdot f_y}{\gamma_{M0}} = \frac{1,318 \cdot 10^{-3} \cdot 275 \cdot 10^3}{1,0} = 362,45 \text{ N}$$

$$\frac{175,69}{362,45} = 0,48 < 1,0$$

6) Buckling of uniform members in compression

$$\frac{N_{Ed}}{N_{b,Rd}} \leq 1,0$$

$$N_{b,Rd} = \frac{\chi \cdot A \cdot f_y}{\gamma_{M0}}$$

$$\lambda_1 = 93,9 \cdot \varepsilon = 93,9 \cdot 0,92 = 86,39$$

Y

$$\lambda_{rel,0,y} = \frac{L_{cr,y}}{i_y} \cdot \frac{1}{\lambda_1} = \frac{1500}{30} \cdot \frac{1}{86,39}$$

$$\lambda_{rel,0,y} = \mathbf{0,58}$$

$$\chi_y = \frac{1}{\Phi_y + \sqrt{\Phi_y^2 - \lambda_{rel,0,y}^2}}$$

$$\Phi_y = 0,5(1 + \alpha(\lambda_{rel,0,y} - 0,2) + \lambda_{rel,0,y}^2)$$

Buckling curve

y-y => c → α = 0,49

$$\Phi_y = 0,5(1 + 0,49(0,58 - 0,2) + 0,58^2)$$

$$\Phi_y = 0,76$$

$$\chi_y = \frac{1}{0,76 + \sqrt{0,76^2 - 0,58^2}}$$

$$\chi_y = \mathbf{0,80}$$

$$N_{b,Rd} = \frac{0,80 \cdot 1,318 \cdot 10^{-3} \cdot 275 \cdot 10^3}{1,0}$$

$$N_{b,Rd,y} = 289,96 \text{ kN}$$

$$\frac{175,69}{289,96} = 0,61 \leq 1,0$$

5.12 Bracing 1 (CFCHS 168.3x8)

N

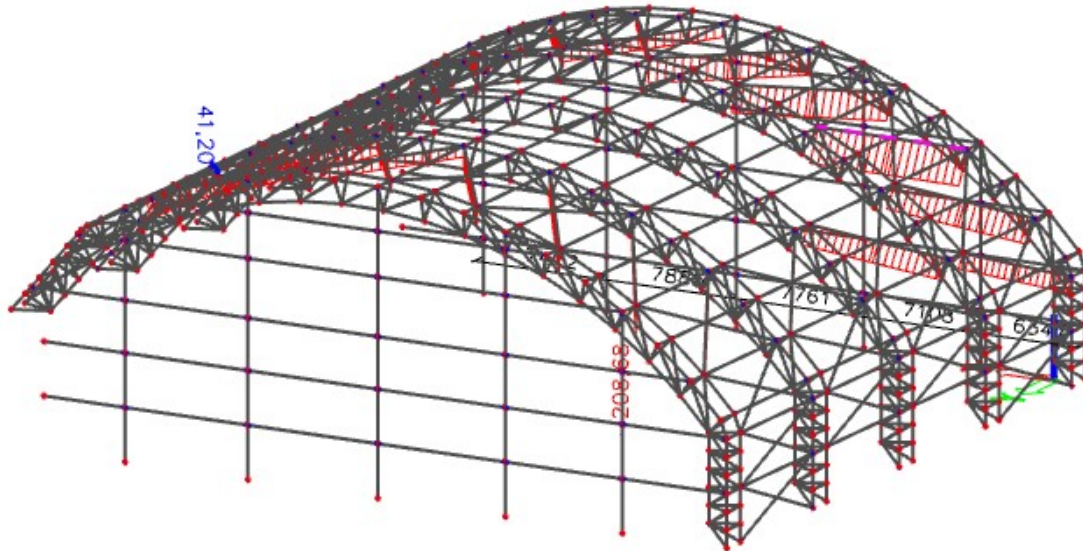

Figure 5.37. Axial force diagram (N)

Relevant combination: ULS128

gsn128 / 1.35*LC1 + 1.50*snow + 1.35*constant load +
1.05*work+inst2

$N = -208,68 \text{ kN}$ (compression)

$M_y = 0 \text{ kNm}$

$V_z = -0 \text{ kN}$

$M_z = 0 \text{ kNm}$

$V_y = 0 \text{ kN}$

- Classification of gable column (CFCHS 168.3x8)

- Section in bending and/or compression

$$\frac{d}{t} \leq 50 \cdot \varepsilon^2$$

$$\frac{168.3}{8} = 21,04 \leq 42,32 \quad \text{class 1}$$

Cross section is in Class 1

1) Compression check

$$\frac{N_{Ed}}{N_{c,Rd}} \leq 1,0$$

$$N_{c,Rd} = \frac{A \cdot f_y}{\gamma_{M0}} = \frac{4,029 \cdot 10^{-3} \cdot 275 \cdot 10^3}{1,0} = 1107,98N$$

$$\frac{208,68}{1107,98} = 0,19 < 1,0$$

2) Buckling of uniform members in compression

$$\frac{N_{Ed}}{N_{b,Rd}} \leq 1,0$$

$$N_{b,Rd} = \frac{\chi \cdot A \cdot f_y}{\gamma_{M0}}$$

$$\lambda_1 = 93,9 \cdot \varepsilon = 93,9 \cdot 0,92 = 86,39$$

Y

$$\lambda_{rel,0,y} = \frac{L_{cr,y}}{i_y} \cdot \frac{1}{\lambda_1} = \frac{9584}{57} \cdot \frac{1}{86,39}$$

$$\lambda_{rel,0,y} = 1,95$$

$$\chi_y = \frac{1}{\Phi_y + \sqrt{\Phi_y^2 - \lambda_{rel,0,y}^2}}$$

$$\Phi_y = 0,5(1 + \alpha(\lambda_{rel,0,y} - 0,2) + \lambda_{rel,0,y}^2)$$

Buckling curve

$$y-y \Rightarrow c \rightarrow \alpha = 0,49$$

$$\Phi_y = 0,5(1 + 0,49(1,95 - 0,2) + 1,95^2)$$

$$\Phi_y = 2,83$$

$$\chi_y = \frac{1}{2,83 + \sqrt{2,83^2 - 1,95^2}}$$

$$\chi_y = 0,20$$

$$N_{b,Rd} = \frac{0,20 \cdot 4,029 \cdot 10^{-3} \cdot 275 \cdot 10^3}{1,0}$$

$$N_{b,Rd,y} = 221,60kN$$

$$\frac{208,68}{221,60} = 0,94 \leq 1,0$$

5.13 Bracing 2 (CFCHS 152.4x5)

N

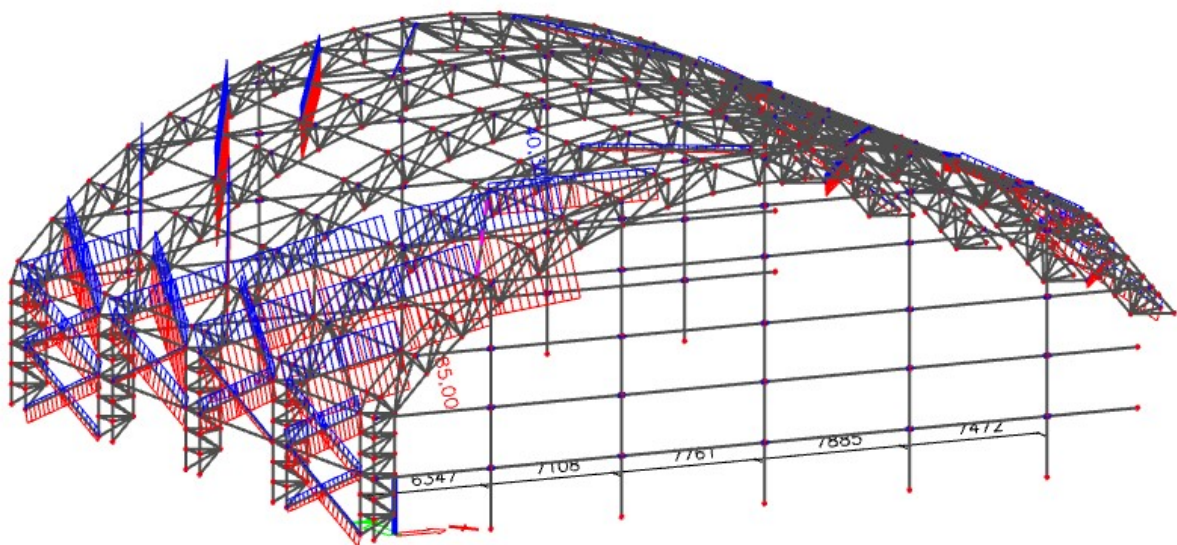

Figure 5.38. Axial force diagram (N)

Relevant combination: ULS46- uplift2

gsn46 uplift2 / LC1 + 1.50*wind -0.3 + constant load

$N = -85,00$ kN (compression)

$M_y = 0$ kNm

$V_z = -0$ kN

$M_z = 0$ kNm

$V_y = 0$ kN

- Classification of gable column (CFCHS 152.4x5)

- Section in bending and/or compression

$$\frac{d}{t} \leq 50 \cdot \varepsilon^2$$

$$\frac{152.4}{5} = 30,48 \leq 42,32 \quad \text{class 1}$$

Cross section is in Class 1

1) Compression check

$$\frac{N_{Ed}}{N_{c,Rd}} \leq 1,0$$

$$N_{c,Rd} = \frac{A \cdot f_y}{\gamma_{M0}} = \frac{2,315 \cdot 10^{-3} \cdot 275 \cdot 10^3}{1,0} = 636,63N$$

$$\frac{85}{636,63} = 0,13 < 1,0$$

2) Buckling of uniform members in compression

$$\frac{N_{Ed}}{N_{b,Rd}} \leq 1,0$$

$$N_{b,Rd} = \frac{\chi \cdot A \cdot f_y}{\gamma_{M0}}$$

$$\lambda_1 = 93,9 \cdot \varepsilon = 93,9 \cdot 0,92 = 86,39$$

Y

$$\lambda_{rel,0,y} = \frac{L_{cr,y}}{i_y} \cdot \frac{1}{\lambda_1} = \frac{9584}{52} \cdot \frac{1}{86,39}$$

$$\lambda_{rel,0,y} = 2,13$$

$$\chi_y = \frac{1}{\Phi_y + \sqrt{\Phi_y^2 - \lambda_{rel,0,y}^2}}$$

$$\Phi_y = 0,5(1 + \alpha(\lambda_{rel,0,y} - 0,2) + \lambda_{rel,0,y}^2)$$

Buckling curve

$$y-y \Rightarrow c \rightarrow \alpha = 0,49$$

$$\Phi_y = 0,5(1 + 0,49(2,13 - 0,2) + 2,13^2)$$

$$\Phi_y = 3,24$$

$$\chi_y = \frac{1}{3,24 + \sqrt{3,24^2 - 2,13^2}}$$

$$\chi_y = 0,18$$

$$N_{b,Rd} = \frac{0,18 \cdot 2,315 \cdot 10^{-3} \cdot 275 \cdot 10^3}{1,0}$$

$$N_{b,Rd,y} = 114,59 \text{ kN}$$

$$\frac{85,0}{114,59} = 0,74 \leq 1,0$$

6. Joints calculation

6.1 Column grid – foundation joint

DETAIL „A“

- Design dimensions of foundation
- C25/30

$$a_1 = \min(3 \cdot a_0, a_0 + h, a_c) = (3 \cdot 420, 420 + 800, 1200) = 1200 \text{ mm}$$

$$b_1 = \min(3 \cdot b_0, b_0 + h, b_c) = (3 \cdot 400, 400 + 800, 1200) = 1200 \text{ mm}$$

- Stress concentration factor

$$k_j = \sqrt{\frac{a_1 \cdot b_1}{a_0 \cdot b_0}} = \sqrt{\frac{1200 \cdot 1200}{420 \cdot 400}} = 2,93$$

- Design strength of concrete $\gamma_c = 1,5$

$$f_{jd} = \frac{\beta_j \cdot k_j \cdot f_{ck}}{\gamma_c} = \frac{2}{3} \cdot \frac{2,93 \cdot 25}{1,5} = 32,56 \text{ MPa}$$

$$c = t_p \cdot \sqrt{\frac{f_{jd}}{3 \cdot f_{jd}}} = 25 \cdot \sqrt{\frac{275}{3 \cdot 32,56}} = 41,46 \text{ mm}$$

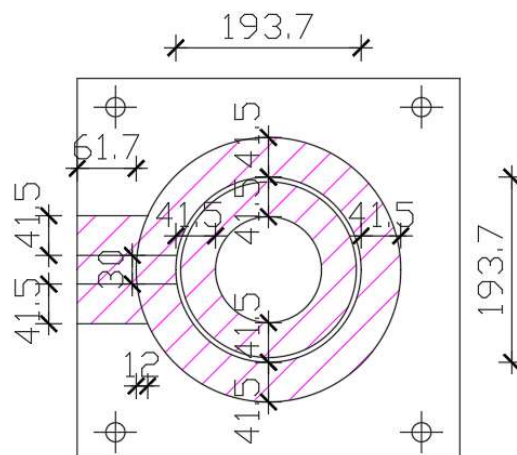

Figure 6.1. Representation of effective area

$$A_{eff} = \pi \cdot \left(\frac{(193,7 + 41,46)^2}{4} - \frac{(193,7 - 41,46)^2}{4} \right) + 2 \cdot 41,46 \cdot 61,7 + 2 \cdot \frac{41,46 \cdot 12}{2}$$

$$= 30843,19 \text{ mm}^2$$

$$N_{Rd} = A_{eff} \cdot f_{jd} = 30843,19 \cdot 33,33 \cdot 10^{-3} = 1028,00 \text{ kN} > N_{Ed} = 272,81 \text{ kN}$$

- Shear strength

$$V = 125,83 \text{ kN}$$

Shear stopper design: SHS 150x150x6

$$A_{v,z} = 1708,3 \text{ mm}^2$$

$$W_{pl,y} = 184000 \text{ mm}^3$$

Assessment

The transmission of horizontal forces can only be considered in contact with concrete of foundation. The necessary length of the shear stopper can be obtained by the following relation:

$$h > \frac{F_{v,Ed}}{b \cdot \frac{f_{ck}}{\gamma_c}} = \frac{125,83 \cdot 10^3}{150 \cdot \frac{25}{1,5}} = 50,33 \text{ mm}$$

$$h = 55 \text{ mm}$$

Shear

$$V_{Rd} = \frac{A_{v,z} \cdot f_y}{\sqrt{3} \cdot \gamma_{M0}} = \frac{1708,3 \cdot 275}{\sqrt{3} \cdot 1,0} = 271,23 \text{ kN} > V_{Ed} = 125,83 \text{ kN}$$

$$0,5 \cdot V_{Rd} = 0,5 \cdot 271,33 = 135,62 \text{ kN} > V_{Ed} = 125,83 \text{ kN}$$

Bending

$$M_{pl,Rd} = W_{pl,y} \cdot f_{yd} = 184000 \cdot 275 = 50,6 \cdot 10^6 \text{ Nmm} = 50,6 \text{ kNm}$$

$$M_{pl,Rd} > M_{Ed} = F_{v,Ed} \cdot e = 125,83 \cdot 10^3 \cdot \left(40 + \frac{55}{2} \right) = 8,49 \cdot 10^6 \text{ Nmm} = 8,49 \text{ kNm}$$

50,6 kNm > 8,49 kNm → shear stopper will satisfied

- Welded connection of the stopper to the plate

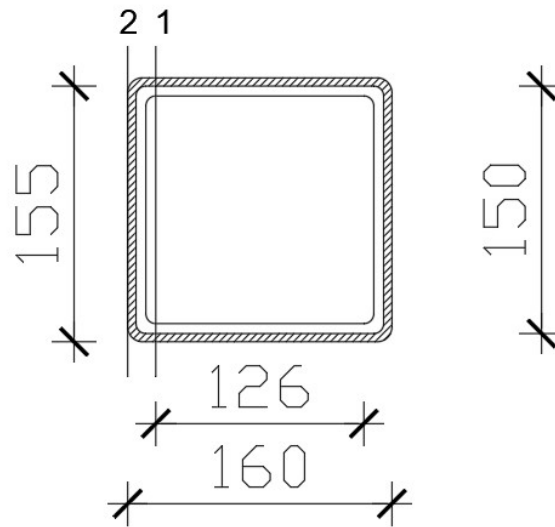

Figure 6.2. representation of welded area

$I_w \rightarrow$ moment of inertia of the weld

For SHS

$$I_w = 2 \cdot \frac{1}{12} \cdot 155^3 \cdot 5 + 0 + 2 \cdot \frac{1}{12} \cdot 155 \cdot 5^3 + 2(155 \cdot 5) \cdot \left(\frac{155}{2}\right)^2$$

$$I_w = 12,42 \cdot 10^6 \text{ mm}^4$$

Assessment in point 1

$$\tau_{II} = \frac{f_{v,Ed}}{2 \cdot a \cdot l} = \frac{125,83 \cdot 10^3}{2 \cdot 5 \cdot 126} = 99,87 \text{ MPa}$$

$$\tau_{\perp} = \sigma_{\perp} = \frac{1}{\sqrt{2}} \cdot \frac{F_{v,Ed} \cdot e}{\frac{I_w}{z_1}} = \frac{1}{\sqrt{2}} \cdot \frac{125,83 \cdot 10^3 \cdot \left(40 + \frac{55}{2}\right)}{\frac{12,42 \cdot 10^6}{\frac{126}{2}}}$$

$$\tau_{\perp} = \sigma_{\perp} = 30,46 \text{ MPa}$$

$$\sqrt{\sigma_{\perp}^2 + 3 \cdot (\tau_{\perp}^2 + \tau_{II}^2)} = \sqrt{30,46^2 + 3 \cdot (30,46^2 + 99,87^2)} = 183,39 \text{ MPa}$$

$$\frac{f_u}{\beta_w \cdot \gamma_{M2}} = \frac{430}{0,85 \cdot 1,25} = 404,71 \text{ MPa}$$

$$183,39 \text{ MPa} < 404,71 \text{ MPa}$$

$$\sigma_{\perp} = 30,46 \text{ MPa} < \frac{f_u \cdot 0,9}{\gamma_{M2}} = \frac{430 \cdot 0,9}{1,25} = 309,6 \text{ MPa}$$

Assessment in point 2

$$\tau_{II} = 0 \text{ MPa}$$

$$\tau_{\perp} = \sigma_{\perp} = \frac{1}{\sqrt{2}} \cdot \frac{F_{v,Ed} \cdot e}{\frac{I_w}{z_2}} = \frac{1}{\sqrt{2}} \cdot \frac{125,83 \cdot 10^3 \cdot \left(40 + \frac{55}{2}\right)}{\frac{12,42 \cdot 10^6}{\frac{160}{2}}} = 38,68 \text{ MPa}$$

$$\sqrt{\sigma_{\perp}^2 + 3 \cdot (\tau_{\perp}^2 + \tau_{II}^2)} = \sqrt{38,68^2 + 3 \cdot (38,68^2 + 0^2)} = 77,36 \text{ MPa}$$

$$77,36 \text{ MPa} < \frac{f_u}{\gamma_{M2} \cdot \beta_w} = \frac{430}{1,25 \cdot 0,85} = 404,71 \text{ MPa}$$

$$\sigma_{\perp} = 38,68 \text{ MPa} < \frac{f_u \cdot 0,9}{\gamma_{M2}} = \frac{430 \cdot 0,9}{1,25} = 309,6 \text{ MPa}$$

6.2 Upper cord connection

DETAIL „B“

- Resistance of the weld

$$\sqrt{\sigma_{\perp}^2 + 3 \cdot (\tau_{\perp}^2 + \tau_{II}^2)} \leq \frac{f_u}{\beta_w \cdot \gamma_{M2}}$$

$$\sigma_{\perp} \leq \frac{f_u \cdot 0,9}{\gamma_{M2}}$$

$$\tau_{\perp} = \sigma_{\perp} = \frac{1}{\sqrt{2}} \cdot \frac{N_{Ed}}{a \cdot l} = \frac{1}{\sqrt{2}} \cdot \frac{224960}{5 \cdot 168,3 \cdot \pi} = 60,17 \text{ MPa}$$

$$\sqrt{60,17^2 + 3 \cdot (60,17^2 + 0^2)} = 120,34 \text{ MPa} < \frac{f_u}{\gamma_{M2} \cdot \beta_w} = \frac{430}{1,25 \cdot 0,85} = 404,71 \text{ MPa}$$

$$\sigma_{\perp} = 60,17 \text{ MPa} < \frac{f_u \cdot 0,9}{\gamma_{M2}} = \frac{430 \cdot 0,9}{1,25} = 309,6 \text{ MPa}$$

- Tension resistance for T-stub

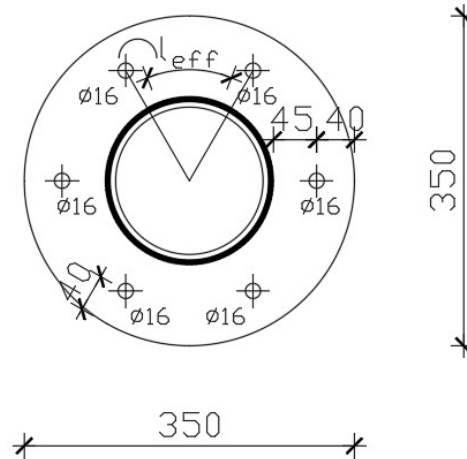

Figure 6.3. representation of plate with bolts

1) Method 1

$$F_{T,1,Rd} = \frac{4 \cdot M_{pl,1,Rd}}{m}$$

$$M_{pl,1,Rd} = 0,25 \cdot \Sigma l_{eff,1} \cdot t_f^2 \cdot f_y / \gamma_{M0}$$

$$\Sigma l_{eff,1} = 2 \cdot \pi \cdot \left(0,8 \cdot 5\sqrt{2} + \frac{168,3}{2} \right)$$

$$\Sigma l_{eff,1} = 564,27 \text{ mm}$$

$$l_{eff,1} = \frac{564,27}{6} = 94,05 \text{ mm}$$

$$F_{T,1,Rd} = 4 \cdot \frac{0,25 \cdot 94,05 \cdot 10^{-3} \cdot 20^2 \cdot 10^{-6} \cdot 275 \cdot 10^3}{1,0 \cdot 45 \cdot 10^{-3}} = 229,9 \text{ kN}$$

$$\frac{6}{2} \cdot F_{T,1,Rd} = 689,7 \text{ kN}$$

2) Method 2

$$F_{T,2,Rd} = \frac{2 \cdot M_{pl,2,Rd} \cdot \Sigma F_{t,Rd}}{m + n}$$

$$n = e_{min} = 40mm$$

$$M_{pl,2,Rd} = 0,25 \cdot \Sigma l_{eff,2} \cdot t_f^2 \cdot f_y / \gamma_{M0}$$

$$\Sigma l_{eff,2} = 564,27mm$$

$$l_{eff,2} = \frac{564,27}{6} = 94,05mm$$

$$F_{T,2,Rd} = 2 \cdot \frac{0,25 \cdot 564,27 \cdot 10^{-3} \cdot 20^2 \cdot 10^{-6} \cdot 275 \cdot 10^3 / 1,0 + 40 \cdot 10^{-3} \cdot 90,4 \cdot 6}{45 \cdot 10^{-3} + 40 \cdot 10^{-3}}$$

$$= 229,9 \text{ kN}$$

$$F_{T,2,Rd} = 620,36 \text{ kN}$$

$$\frac{F_{T,2,Rd}}{2} = \frac{620,36}{2} = 310,18 \text{ kN}$$

3) Method 3

$$F_{T,3,Rd} = \Sigma F_{t,Rd} = 6 \cdot 90,4 = 542,4 \text{ kN}$$

$$\min F_{T,i,Rd} = F_{T,2,Rd} = 310,18 \text{ kN} > N_{Ed} = 224,96 \text{ kN}$$

- Resistance of bolts in tension

$$\frac{F_{t,Ed}}{F_{t,Rd}} \leq 1,0$$

$$F_{t,Rd} = 90,4 \text{ kN} \rightarrow \text{tension resistance of 1 bolt}$$

$$F_{t,Ed} = \frac{224,96}{6} = 37,49 \text{ kN} \rightarrow \text{tension force for one bolt}$$

$$\frac{F_{t,Ed}}{F_{t,Rd}} = \frac{37,49}{90,4} = 0,41 < 1,0 \text{ satisfied}$$

- Combined tension and shear

$$\frac{F_{v,Ed}}{F_{v,Rd}} + \frac{F_{t,Ed}}{1,4 \cdot F_{t,Rd}} \leq 1,0$$

$$F_{t,Rd} = 90,4 \text{ kN} \rightarrow \text{tension resistance of 1 bolt}$$

$$F_{t,Ed} = \frac{224,96}{6} = 37,49 \text{ kN} \rightarrow \text{tension force for one bolt}$$

$$F_{v,Rd} = 77,2 \text{ kN} \rightarrow \text{shear resistance of 1 bolt}$$

$$F_{v,Ed} = \frac{2,0}{6} = 0,33 \text{ kN} \rightarrow \text{shear force for one bolt}$$

$$\frac{0,33}{77,2} + \frac{37,49}{1,4 \cdot 90,4} = 0,30 < 1,0$$

6.3 Lower cord connection

DETAIL „C“

- Resistance of the weld

$$\sqrt{\sigma_{\perp}^2 + 3 \cdot (\tau_{\perp}^2 + \tau_{II}^2)} \leq \frac{f_u}{\beta_w \cdot \gamma_{M2}}$$

$$\sigma_{\perp} \leq \frac{f_u \cdot 0,9}{\gamma_{M2}}$$

$$\tau_{\perp} = \sigma_{\perp} = \frac{1}{\sqrt{2}} \cdot \frac{N_{Ed}}{a \cdot l} = \frac{1}{\sqrt{2}} \cdot \frac{81980}{5 \cdot 139,7 \cdot \pi} = 26,42 \text{ MPa}$$

$$\sqrt{26,42^2 + 3 \cdot (26,42^2 + 0^2)} = 52,84 \text{ MPa} < \frac{f_u}{\gamma_{M2} \cdot \beta_w} = \frac{430}{1,25 \cdot 0,85} = 404,71 \text{ MPa}$$

$$\sigma_{\perp} = 26,42 \text{ MPa} < \frac{f_u \cdot 0,9}{\gamma_{M2}} = \frac{430 \cdot 0,9}{1,25} = 309,6 \text{ MPa}$$

- Tension resistance for T-stub

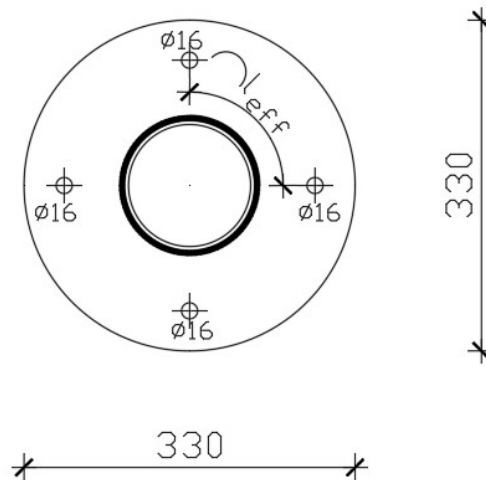

Figure 6.4. representation of plate with bolts

- 1) Method 1

$$F_{T,1,Rd} = \frac{4 \cdot M_{pl,1,Rd}}{m}$$

$$M_{pl,1,Rd} = 0,25 \cdot \Sigma l_{eff,1} \cdot t_f^2 \cdot f_y / \gamma_{M0}$$

$$\Sigma l_{eff,1} = 2 \cdot \pi \cdot \left(0,8 \cdot 5\sqrt{2} + \frac{139,7}{2} \right)$$

$$\Sigma l_{eff,1} = 474,42 \text{ mm}$$

$$l_{eff,1} = \frac{564,27}{4} = 118,61 \text{ mm}$$

$$F_{T,1,Rd} = 4 \cdot \frac{0,25 \cdot 118,61 \cdot 10^{-3} \cdot 20^2 \cdot 10^{-6} \cdot 275 \cdot 10^3}{1,0 \cdot 50 \cdot 10^{-3}} = 260,94 \text{ kN}$$

$$\frac{4}{2} \cdot F_{T,1,Rd} = 521,88 \text{ kN}$$

2) Method 2

$$F_{T,2,Rd} = \frac{2 \cdot M_{pl,2,Rd} \cdot \Sigma F_{t,Rd}}{m + n}$$

$$n = e_{min} = 40 \text{ mm}$$

$$m = 50 \text{ mm}$$

$$M_{pl,2,Rd} = 0,25 \cdot \Sigma l_{eff,2} \cdot t_f^2 \cdot f_y / \gamma_{M0}$$

$$\Sigma l_{eff,2} = 474,42 \text{ mm}$$

$$l_{eff,2} = \frac{474,42}{4} = 118,61 \text{ mm}$$

$$F_{T,2,Rd} = 2 \cdot \frac{0,25 \cdot 474,42 \cdot 10^{-3} \cdot 20^2 \cdot 10^{-6} \cdot 275 \cdot 10^3 / 1,0 + 40 \cdot 10^{-3} \cdot 90,4 \cdot 4}{40 \cdot 10^{-3} + 50 \cdot 10^{-3}}$$

$$= 450,63 \text{ kN}$$

$$F_{T,2,Rd} = 450,63 \text{ kN}$$

$$\frac{F_{T,2,Rd}}{2} = \frac{450,63}{2} = 225,32 \text{ kN}$$

3) Method 3

$$F_{T,3,Rd} = \Sigma F_{t,Rd} = 4 \cdot 90,4 = 361,6 \text{ kN}$$

$$\min F_{T,i,Rd} = F_{T,2,Rd} = 225,32 \text{ kN} > N_{Ed} = 81,98 \text{ kN}$$

- Resistance of bolts in tension

$$\frac{F_{t,Ed}}{F_{t,Rd}} \leq 1,0$$

$$F_{t,Rd} = 90,4 \text{ kN} \rightarrow \text{tension resistance of 1 bolt}$$

$$F_{t,Ed} = \frac{81,98}{4} = 20,5 \text{ kN} \rightarrow \text{tension force for one bolt}$$

$$\frac{F_{t,Ed}}{F_{t,Rd}} = \frac{20,50}{90,4} = 0,22 < 1,0 \text{ satisfied}$$

- Combined tension and shear

$$\frac{F_{v,Ed}}{F_{v,Rd}} + \frac{F_{t,Ed}}{1,4 \cdot F_{t,Rd}} \leq 1,0$$

$$F_{t,Rd} = 90,4 \text{ kN} \rightarrow \text{tension resistance of 1 bolt}$$

$$F_{t,Ed} = \frac{81,98}{4} = 20,50 \text{ kN} \rightarrow \text{tension force for one bolt}$$

$$F_{v,Rd} = 77,2 \text{ kN} \rightarrow \text{shear resistance of 1 bolt}$$

$$F_{v,Ed} = \frac{0,24}{4} = 0,06 \text{ kN} \rightarrow \text{shear force for one bolt}$$

$$\frac{0,06}{77,2} + \frac{20,50}{1,4 \cdot 90,4} = 0,16 < 1,0$$

6.4 Diagonal cord connection

DETAIL „D“

- Resistance of the weld

$$\sqrt{\sigma_{\perp}^2 + 3 \cdot (\tau_{\perp}^2 + \tau_{II}^2)} \leq \frac{f_u}{\beta_w \cdot \gamma_{M2}}$$

$$\sigma_{\perp} \leq \frac{f_u \cdot 0,9}{\gamma_{M2}}$$

$$\tau_{\perp} = \sigma_{\perp} = \frac{1}{\sqrt{2}} \cdot \frac{N_{Ed}}{a \cdot l} = \frac{1}{\sqrt{2}} \cdot \frac{64570}{5 \cdot 88,9 \cdot \pi} = 32,70 \text{ MPa}$$

$$\sqrt{32,70^2 + 3 \cdot (32,70^2 + 0^2)} = 65,4 \text{ MPa} < \frac{f_u}{\gamma_{M2} \cdot \beta_w} = \frac{430}{1,25 \cdot 0,85} = 404,71 \text{ MPa}$$

$$\sigma_{\perp} = 32,7 \text{ MPa} < \frac{f_u \cdot 0,9}{\gamma_{M2}} = \frac{430 \cdot 0,9}{1,25} = 309,6 \text{ MPa}$$

- Tension resistance for T-stub

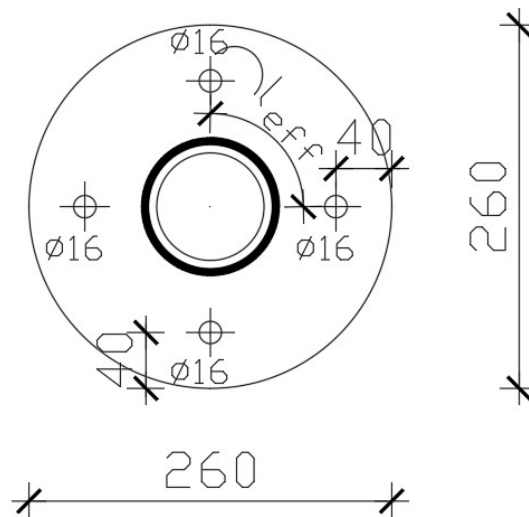

Figure 6.5. representation of plate with bolts

4) Method 1

$$F_{T,1,Rd} = \frac{4 \cdot M_{pl,1,Rd}}{m}$$

$$M_{pl,1,Rd} = 0,25 \cdot \Sigma l_{eff,1} \cdot t_f^2 \cdot f_y / \gamma_{M0}$$

$$\Sigma l_{eff,1} = 2 \cdot \pi \cdot \left(0,8 \cdot 5\sqrt{2} + \frac{88,9}{2} \right)$$

$$\Sigma l_{eff,1} = 314,83 \text{ mm}$$

$$l_{eff,1} = \frac{314,83}{4} = 78,71 \text{ mm}$$

$$F_{T,1,Rd} = 4 \cdot \frac{0,25 \cdot 78,71 \cdot 10^{-3} \cdot 20^2 \cdot 10^{-6} \cdot 275 \cdot 10^3}{1,0 \cdot 40 \cdot 10^{-3}} = 216,45 \text{ kN}$$

$$\frac{4}{2} \cdot F_{T,1,Rd} = 432,9 \text{ kN}$$

5) Method 2

$$F_{T,2,Rd} = \frac{2 \cdot M_{pl,2,Rd} \cdot \Sigma F_{t,Rd}}{m + n}$$

$$n = e_{min} = 40 \text{ mm}$$

$$m = 40 \text{ mm}$$

$$M_{pl,2,Rd} = 0,25 \cdot \Sigma l_{eff,2} \cdot t_f^2 \cdot f_y / \gamma_{M0}$$

$$\Sigma l_{eff,2} = 314,83 \text{ mm}$$

$$l_{eff,2} = \frac{314,83}{4} = 78,71 \text{ mm}$$

$$F_{T,2,Rd} = 2 \cdot \frac{0,25 \cdot 314,83 \cdot 10^{-3} \cdot 20^2 \cdot 10^{-6} \cdot 275 \cdot 10^3 / 1,0 + 40 \cdot 10^{-3} \cdot 90,4 \cdot 4}{40 \cdot 10^{-3} + 40 \cdot 10^{-3}} = 450,63 \text{ kN}$$

$$F_{T,2,Rd} = 397,25 \text{ kN}$$

$$\frac{F_{T,2,Rd}}{2} = \frac{397,25}{2} = 198,63 \text{ kN}$$

6) Method 3

$$F_{T,3,Rd} = \Sigma F_{t,Rd} = 4 \cdot 90,4 = 361,6 \text{ kN}$$

$$\min F_{T,i,Rd} = F_{T,2,Rd} = 198,63 \text{ kN} > N_{Ed} = 81,98 \text{ kN}$$

- Resistance of bolts in tension

$$\frac{F_{t,Ed}}{F_{t,Rd}} \leq 1,0$$

$$F_{t,Rd} = 90,4 \text{ kN} \rightarrow \text{tension resistance of 1 bolt}$$

$$F_{t,Ed} = \frac{64,57}{4} = 16,14 \text{ kN} \rightarrow \text{tension force for one bolt}$$

$$\frac{F_{t,Ed}}{F_{t,Rd}} = \frac{16,14}{90,4} = 0,18 < 1,0 \text{ satisfied}$$

6.5 Welded gap „N“ joint

DETAIL „E“

1) Range of validity for welded joints between CHS brace members and CHS chords

$$- \frac{d_1}{d_0} = \frac{60,3}{168,3} = 0,35 > 0,2$$

$$- \frac{d_0}{t_0} = \frac{168,3}{6} = 28,05 \rightarrow 10 < 28,05 < 50$$

$$- \frac{d_1}{t_1} = \frac{60,3}{3} = 20,1 \rightarrow 10 < 20,1 < 50$$

$$- \frac{d_2}{t_2} = \frac{88,9}{6} = 14,82 \rightarrow 10 < 14,82 < 50$$

→ gap

$$g \geq t_1 + t_2 \rightarrow g = 10,1 \text{ mm} > 3 + 6 = 9 \text{ mm}$$

2) Axial resistances of welded joints between CHS brace members and CHS chords

a) Chord face failure

$$N_{1,Rd} = \frac{k_g \cdot k_p \cdot f_{y0} \cdot t_0^2}{\sin \theta_1} \cdot \left(1,8 + 10,2 \cdot \frac{d_1}{d_0}\right) / \gamma_{M5}$$

$$\gamma = \frac{d_0}{2 \cdot t_0} = \frac{168,3}{2 \cdot 6} = 14,03$$

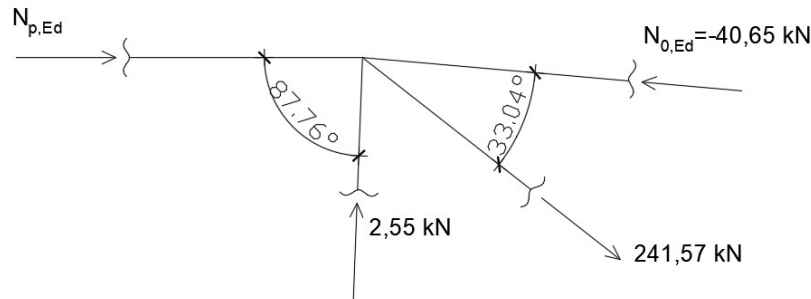

Figure 6.6. representation of forces in beams

$$N_{p,Ed} = N_{0,Ed} - N_{1,Ed} \cdot \cos \theta_1 - N_{2,Ed} \cdot \cos \theta_2 = -40,65 - 2,55 \cdot \cos 87,76 - 241,57 \cdot \cos 33,04$$

$$N_{p,Ed} = -243,26 \text{ kN}$$

$$\sigma_{p,Ed} = \frac{N_{p,Ed}}{A_0} = \frac{-243,26}{\frac{16,83^2 \cdot \pi}{4} - \frac{(16,83 - 2 \cdot 0,6)^2 \cdot \pi}{4}} = -7,95 \text{ kN/cm}^2$$

$$n_p = (\sigma_{p,Ed} / f_y) / \gamma_{M5} = (-7,95 / 27,5) / 1,0 = -0,3$$

$$k_g = \gamma^{0,2} \cdot \left(1 + \frac{0,024 \cdot \gamma^{1,2}}{1 + e^{\left(\frac{0,5 \cdot g}{t_0} - 1,33\right)}}\right) = 14,03^{0,2} \cdot \left(1 + \frac{0,024 \cdot 14,03^{1,2}}{1 + e^{\left(\frac{0,5 \cdot 10,1}{6} - 1,33\right)}}\right)$$

$$k_g = 2,30$$

$$n_p < 0 \rightarrow k_p = 1,0$$

$$N_{1,Rd} = \frac{2,3 \cdot 1,0 \cdot 27,5 \cdot 0,6^2}{\sin 87,76} \cdot \left(1,8 + 10,2 \cdot \frac{60,3}{168,3}\right) / 1,0$$

$$N_{1,Rd} = 124,29 \text{ kN} > N_{1,Ed} = 10,06 \text{ kN}$$

$$N_{2,Rd} = \frac{k_g \cdot k_p \cdot f_{y0} \cdot t_0^2}{\sin \theta_2} \cdot \left(1,8 + 10,2 \cdot \frac{d_2}{d_0}\right) / \gamma_{M5}$$

$$\gamma = \frac{d_0}{2 \cdot t_0} = \frac{168,3}{2 \cdot 6} = 14,03$$

$$n_p = (\sigma_{p,Ed}/f_y)/\gamma_{M5} = (-7,95/27,5)/1,0 = -0,3$$

$$n_p < 0 \text{ (tension)} \rightarrow k_p = 1,0$$

$$k_g = 2,30$$

$$N_{2,Rd} = \frac{2,3 \cdot 1,0 \cdot 27,5 \cdot 0,6^2}{\sin 33,04} \cdot \left(1,8 + 10,2 \cdot \frac{88,9}{168,3}\right) / 1,0$$

$$N_{2,Rd} = 300,18 \text{ kN} > N_{2,Ed} = 241,57 \text{ kN}$$

b) Punching shear failure

$$d_1 \leq d_0 - 2 \cdot t_0 = 168,3 - 2 \cdot 6 = 156,3 \text{ mm}$$

$$60,3 \text{ mm} < 156,3 \text{ mm}$$

$$N_{1,Rd} = \frac{f_y}{\sqrt{3}} \cdot t_0 \cdot \pi \cdot d_1 \cdot \frac{1 + \sin \theta_1}{2 \cdot (\sin \theta_1)^2} / \gamma_{M5} = \frac{27,5}{\sqrt{3}} \cdot 0,6 \cdot \pi \cdot 6,03 \cdot \frac{1 + \sin 87,76}{2 \cdot (\sin 87,75)^2} / 1,0$$

$$N_{1,Rd} = 180,67 \text{ kN} > N_{1,Ed} = 10,06 \text{ kN}$$

$$N_{2,Rd} = \frac{f_y}{\sqrt{3}} \cdot t_0 \cdot \pi \cdot d_2 \cdot \frac{1 + \sin \theta_2}{2 \cdot (\sin \theta_2)^2} / \gamma_{M5} = \frac{27,5}{\sqrt{3}} \cdot 0,6 \cdot \pi \cdot 8,89 \cdot \frac{1 + \sin 33,04}{2 \cdot (\sin 33,04)^2} / 1,0$$

$$N_{2,Rd} = 691,49 \text{ kN} > N_{2,Ed} = 241,57 \text{ kN}$$

c) Shear failure

$$\left(\frac{N_i \cdot \sin \theta_1}{V_{pl}}\right)^2 + \left(\frac{N_{0,gap}}{N_{pl}}\right)^2 \leq 1,0$$

$$N_{0,gap} \leq A_0 \cdot f_y \cdot \sqrt{1 - \left(\frac{N_i \cdot \sin \theta_1}{0,58 \cdot f_y \cdot A_v}\right)^2}$$

$$A_0 = \frac{16,83^2 \cdot \pi}{4} - \frac{(16,83 - 2 \cdot 0,6)^2 \cdot \pi}{4} = 30,59 \text{ cm}^2$$

$$V_{pl} = A_v \cdot \frac{f_y}{\sqrt{3}} = \frac{2}{\pi} \cdot A_0 \cdot \frac{f_y}{\sqrt{3}} = \frac{2}{\pi} \cdot 30,59 \cdot \frac{27,5}{\sqrt{3}} = 309,19 \text{ kN}$$

$$N_{pl} = A_0 \cdot f_y = 30,59 \cdot 27,5 = 841,23 \text{ kN}$$

$$N_{0,gap,1} \leq 30,59 \cdot 27,5 \cdot \sqrt{1 - \left(\frac{2,55 \cdot \sin 87,76}{0,58 \cdot 27,5 \cdot \frac{2}{\pi} \cdot 30,59} \right)^2} = 841,20 \text{ kN}$$

$$N_{0,gap,2} \leq 30,59 \cdot 27,5 \cdot \sqrt{1 - \left(\frac{241,57 \cdot \sin 33,04}{0,58 \cdot 27,5 \cdot \frac{2}{\pi} \cdot 30,59} \right)^2} = 761,85 \text{ kN}$$

$$N_{0,gap,1} = N_2 \cdot \cos \theta_2 + N_{0,Ed} = 241,57 \cdot \cos 33,04 + 40,65 = 243,16 \text{ kN}$$

$$N_{0,gap,2} = N_1 \cdot \cos \theta_1 + N_{0,Ed} = 2,55 \cdot \cos 87,76 + 40,65 = 40,75 \text{ kN}$$

$$243,16 \text{ kN} < 841,20 \text{ kN}$$

$$40,75 \text{ kN} \leq 761,85 \text{ kN}$$

$$\left(\frac{2,55 \cdot \sin 87,76}{309,19} \right)^2 + \left(\frac{243,16}{841,23} \right)^2 = 0,10 < 1,0$$

$$\left(\frac{241,57 \cdot \sin 33,04}{309,19} \right)^2 + \left(\frac{40,75}{841,23} \right)^2 = 0,20 < 1,0$$

6.6 Welded gap „KT“ joint

DETAIL „F“

1) Range of validity for welded joints between CHS brace members and CHS cords

$$- \frac{d_1}{d_0} = \frac{60,3}{168,3} = 0,35 > 0,2$$

$$- \frac{d_0}{t_0} = \frac{168,3}{6} = 28,05 \rightarrow 10 < 28,05 < 50$$

$$- \frac{d_1}{t_1} = \frac{d_2}{t_2} = \frac{88,9}{6} = 14,82 \rightarrow 10 < 14,82 < 50$$

$$- \frac{d_3}{t_3} = \frac{60,3}{6} = 20,1 \rightarrow 10 < 20,1 < 50$$

→ gap

$$g_1 \geq t_1 + t_3 \rightarrow g = 17,5 \text{ mm} > 3 + 6 = 9 \text{ mm}$$

$$g_2 \geq t_3 + t_2 \rightarrow g = 10,1 \text{ mm} > 3 + 6 = 9 \text{ mm}$$

2) Axial resistances of welded joints between CHS brace members and CHS chords

a) Chord face failure

- Design criteria

$$N_{1,Ed} \cdot \sin \theta_1 + N_{3,Ed} \cdot \sin \theta_3 \leq N_{1,Rd} \cdot \sin \theta_1$$

$$N_{2,Ed} \cdot \sin \theta_2 \leq N_{1,Rd} \cdot \sin \theta_1$$

$$N_{1,Rd} = \frac{k_g \cdot k_p \cdot f_{y0} \cdot t_0^2}{\sin \theta_1} \cdot \left(1,8 + 10,2 \cdot \frac{d_1 + d_2 + d_3}{d_0} \right) / \gamma_{M5}$$

$$\gamma = \frac{d_0}{2 \cdot t_0} = \frac{168,3}{2 \cdot 6} = 14,03$$

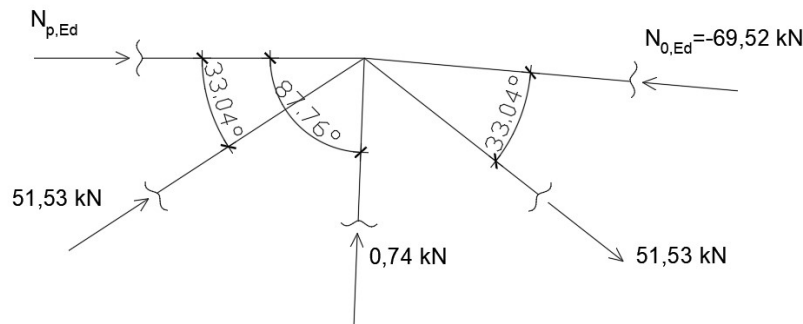

Figure 6.7. representation of forces in beams

$$N_{p,Ed} = N_{0,Ed} - N_{1,Ed} \cdot \cos \theta_1 - N_{2,Ed} \cdot \cos \theta_2 - N_{3,Ed} \cdot \cos \theta_3 = -69,52 - 72,32 \cdot \cos 33,04 - 51,53 \cdot \cos 33,04 - 0,74 \cdot \cos 87,76$$

$$N_{p,Ed} = -173,37 \text{ kN}$$

$$\sigma_{p,Ed} = \frac{N_{p,Ed}}{A_0} = \frac{-173,37}{\frac{16,83^2 \cdot \pi}{4} - \frac{(16,83 - 2 \cdot 0,6)^2 \cdot \pi}{4}} = -5,67 \text{ kN/cm}^2$$

$$n_p = (\sigma_{p,Ed} / f_y) / \gamma_{M5} = (-5,67 / 27,5) / 1,0 = -0,21$$

$$k_{g,1} = \gamma^{0,2} \cdot \left(1 + \frac{0,024 \cdot \gamma^{1,2}}{1 + e^{\left(\frac{0,5 \cdot g}{t_0} - 1,33\right)}} \right) = 14,03^{0,2} \cdot \left(1 + \frac{0,024 \cdot 14,03^{1,2}}{1 + e^{\left(\frac{0,5 \cdot 17,5}{6} - 1,33\right)}} \right)$$

$$k_{g,2} = 14,03^{0,2} \cdot \left(1 + \frac{0,024 \cdot 14,03^{1,2}}{1 + e^{\left(\frac{0,5 \cdot 10,1}{6} - 1,33\right)}} \right)$$

$$k_{g,1} = 2,15$$

$$k_{g,2} = 2,30$$

$$n_p < 0 \text{ (tension)} \rightarrow k_p = 1,0$$

$$(1) \quad N_{1,Rd} = \frac{2,15 \cdot 1,0 \cdot 27,5 \cdot 0,6^2}{\sin 33,04} \cdot \left(1,8 + 10,2 \cdot \frac{88,9 + 88,9 + 60,3}{3 \cdot 168,3} \right) / 1,0$$

$$(2) \quad N_{1,Rd} = \frac{2,30 \cdot 1,0 \cdot 27,5 \cdot 0,6^2}{\sin 33,04} \cdot \left(1,8 + 10,2 \cdot \frac{88,9 + 88,9 + 60,3}{3 \cdot 168,3} \right) / 1,0$$

$$(1) \quad N_{1,Rd} = 258,05 \text{ kN}$$

$$(2) \quad N_{1,Rd} = 274,85 \text{ kN}$$

$$- \quad N_{1,Ed} \cdot \sin \theta_1 + N_{3,Ed} \cdot \sin \theta_3 = 72,32 \cdot \sin 33,04 + 0,74 \cdot \sin 87,76 \leq N_{1,Rd} \cdot \sin \theta_1 = 258,05 \cdot \sin 33,04$$

$$40,17 \text{ kN} < 140,7 \text{ kN}$$

$$- \quad N_{2,Ed} \cdot \sin \theta_2 = 51,53 \cdot \sin 33,04 \leq N_{1,Rd} \cdot \sin \theta_1 = 258,05 \cdot \sin 33,04$$

$$28,1 \text{ kN} < 140,7 \text{ kN}$$

d) Punching shear failure

$$(1) \text{ and } (2) \quad d_{1,2} \leq d_0 - 2 \cdot t_0 = 168,3 - 2 \cdot 6 = 156,3 \text{ mm}$$

$$88,9 \text{ mm} < 156,3 \text{ mm}$$

$$(3) \quad d_3 \leq d_0 - 2 \cdot t_0 = 168,3 - 2 \cdot 6 = 156,3 \text{ mm}$$

$$60,3 \text{ mm} < 156,3 \text{ mm}$$

For (1) and (2)

$$N_{1,2,Rd} = \frac{f_y}{\sqrt{3}} \cdot t_0 \cdot \pi \cdot d_{1,2} \cdot \frac{1 + \sin \theta_{1,2}}{2 \cdot (\sin \theta_{1,2})^2} / \gamma_{M5} = \frac{27,5}{\sqrt{3}} \cdot 0,6 \cdot \pi \cdot 8,89 \cdot \frac{1 + \sin 33,04}{2 \cdot (\sin 33,04)^2} / 1,0$$

$$N_{1,Rd} = N_{2,Rd} = 691,49 \text{ kN} > N_{1,Ed} = 72,32 \text{ kN} \\ > N_{1,Ed} = 51,53 \text{ kN}$$

For (3)

$$N_{3,Rd} = \frac{f_y}{\sqrt{3}} \cdot t_0 \cdot \pi \cdot d_3 \cdot \frac{1 + \sin \theta_3}{2 \cdot (\sin \theta_3)^2} / \gamma_{M5} = \frac{27,5}{\sqrt{3}} \cdot 0,6 \cdot \pi \cdot 6,03 \cdot \frac{1 + \sin 87,76}{2 \cdot (\sin 87,76)^2} / 1,0$$

$$N_{3,Rd} = 180,67 \text{ kN} > N_{2,Ed} = 0,74 \text{ kN}$$

e) Shear failure

$$\left(\frac{N_i \cdot \sin \theta_1}{V_{pl}}\right)^2 + \left(\frac{N_{0,gap}}{N_{pl}}\right)^2 \leq 1,0$$

$$N_{0,gap} \leq A_0 \cdot f_y \cdot \sqrt{1 - \left(\frac{N_i \cdot \sin \theta_1}{0,58 \cdot f_y \cdot A_v}\right)^2}$$

$$A_0 = \frac{16,83^2 \cdot \pi}{4} - \frac{(16,83 - 2 \cdot 0,6)^2 \cdot \pi}{4} = 30,59 \text{ cm}^2$$

$$V_{pl} = A_v \cdot \frac{f_y}{\sqrt{3}} = \frac{2}{\pi} \cdot A_0 \cdot \frac{f_y}{\sqrt{3}} = \frac{2}{\pi} \cdot 30,59 \cdot \frac{27,5}{\sqrt{3}} = 309,19 \text{ kN}$$

$$N_{pl} = A_0 \cdot f_y = 30,59 \cdot 27,5 = 841,23 \text{ kN}$$

$$N_{0,gap,1} \leq 30,59 \cdot 27,5 \cdot \sqrt{1 - \left(\frac{72,32 \cdot \sin 33,04}{0,58 \cdot 27,5 \cdot \frac{2}{\pi} \cdot 30,59}\right)^2} = 834,42 \text{ kN}$$

$$N_{0,gap,2} \leq 30,59 \cdot 27,5 \cdot \sqrt{1 - \left(\frac{51,53 \cdot \sin 33,04}{0,58 \cdot 27,5 \cdot \frac{2}{\pi} \cdot 30,59}\right)^2} = 837,78 \text{ kN}$$

$$N_{0,gap,1} = N_{0,Ed} + N_2 \cdot \cos \theta_2 = 69,52 + 51,53 \cdot \cos 33,04 = 117,72 \text{ kN}$$

$$N_{0,gap,2} = N_{0,Ed} + N_1 \cdot \cos \theta_1 = 69,52 + 72,32 \cdot \cos 33,04 = 130,15 \text{ kN}$$

$$117,72 \text{ kN} < 834,42 \text{ kN}$$

$$130,15 \text{ kN} \leq 837,78 \text{ kN}$$

$$\left(\frac{72,32 \cdot \sin 33,04}{309,19}\right)^2 + \left(\frac{117,72}{841,23}\right)^2 = 0,04 < 1,0$$

$$\left(\frac{51,53 \cdot \sin 33,04}{309,19}\right)^2 + \left(\frac{130,15}{841,23}\right)^2 = 0,04 < 1,0$$

6.7 Column grid – foundation joint

DETAIL „G“

- Design dimensions of foundation
- C25/30

$$a_1 = \min(3 \cdot a_0, a_0 + h, a_c) = (3 \cdot 440, 440 + 800, 1500) = 1240 \text{ mm}$$

$$b_1 = \min(3 \cdot b_0, b_0 + h, b_c) = (3 \cdot 700, 700 + 800, 2000) = 1500 \text{ mm}$$

- Stress concentration factor

$$k_j = \sqrt{\frac{a_1 \cdot b_1}{a_0 \cdot b_0}} = \sqrt{\frac{1240 \cdot 1500}{440 \cdot 700}} = 2,46$$

- Design strength of concrete $\gamma_c = 1,5$

$$f_{jd} = \frac{\beta_j \cdot k_j \cdot f_{ck}}{\gamma_c} = \frac{2}{3} \cdot \frac{2,46 \cdot 25}{1,5} = 27,33 \text{ MPa}$$

$$c = t_p \cdot \sqrt{\frac{f_{jd}}{3 \cdot f_{jd}}} = 20 \cdot \sqrt{\frac{275}{3 \cdot 27,33}} = 36,6 \text{ mm}$$

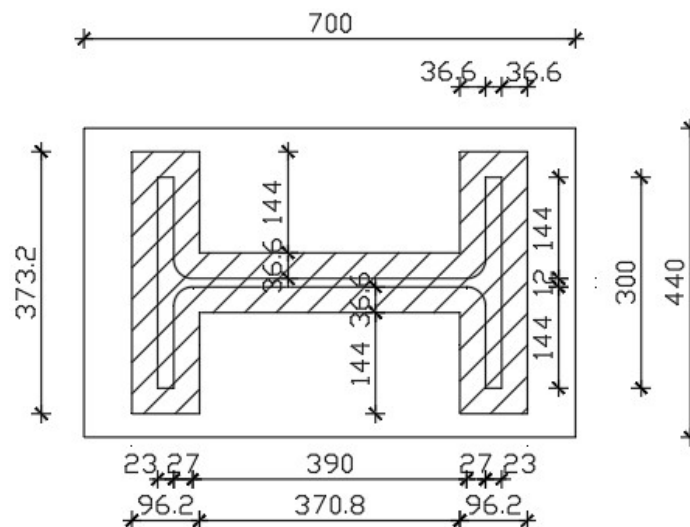

Figure 6.8. representation of effective area

$$A_{eff} = (300 + 2 \cdot 36,6) \cdot (23 + 2 \cdot 36,6) \cdot 2 + (12 + 2 \cdot 36,6) \cdot (490 - 2 \cdot 23 - 2 \cdot 36,6) \\ = 103395,84 \text{ mm}^2$$

$$N_{Rd} = A_{eff} \cdot f_{jd} = 103395,84 \cdot 27,33 \cdot 10^{-3} = 2825,81 \text{ kN} > N_{Ed} = 105,08 \text{ kN}$$

- Shear strength

$$V = 89,99 \text{ kN}$$

Shear stopper design: HEA 180

$$A_{v,z} = 1447,0 \text{ mm}^2$$

$$W_{pl,y} = 324900 \text{ mm}^3$$

Assessment

The transmission of horizontal forces can only be considered in contact with concrete of foundation. The necessary length of the shear stopper can be obtained by the following relation:

$$h > \frac{F_{v,Ed}}{b \cdot \frac{f_{ck}}{\gamma_c}} = \frac{89,99 \cdot 10^3}{180 \cdot \frac{25}{1,5}} = 29,99 \text{ mm}$$

$$h = 50 \text{ mm}$$

Shear

$$V_{Rd} = \frac{A_{v,z} \cdot f_y}{\sqrt{3} \cdot \gamma_{M0}} = \frac{1447 \cdot 275}{\sqrt{3} \cdot 1,0} = 229,74 \text{ kN} > V_{Ed} = 89,99 \text{ kN}$$

$$0,5 \cdot V_{Rd} = 0,5 \cdot 229,74 = 114,87 \text{ kN} > V_{Ed} = 89,99 \text{ kN}$$

Bending

$$M_{pl,Rd} = W_{pl,y} \cdot f_{yd} = 324900 \cdot 275 = 89,35 \cdot 10^6 \text{ Nmm} = 89,35 \text{ kNm}$$

$$M_{pl,Rd} > M_{Ed} = F_{v,Ed} \cdot e = 89,99 \cdot 10^3 \cdot \left(40 + \frac{50}{2}\right) = 5,85 \cdot 10^6 \text{ Nmm} = 5,85 \text{ kNm}$$

$$89,35 \text{ kNm} > 5,85 \text{ kNm} \rightarrow \text{shear stopper will satisfied}$$

- Welded connection of the stopper to the plate

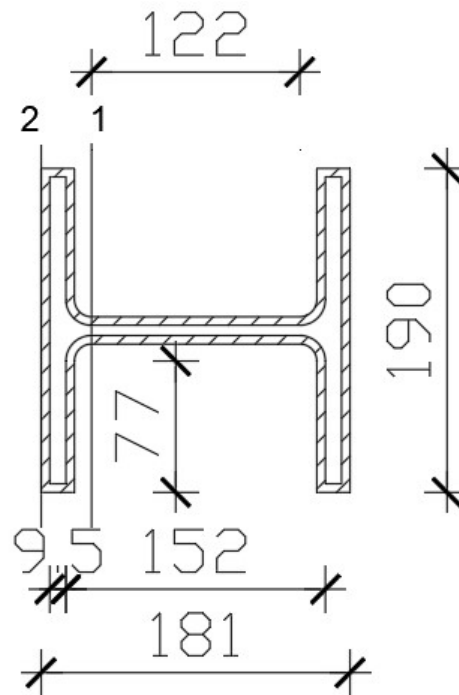

Figure 6.9. Representation of welded area

$I_w \rightarrow$ moment of inertia of the weld

For HEA

$$I_w = 2 \cdot \frac{190^3 \cdot 5}{12} + 0 + 2 \cdot \frac{152 \cdot 5^3}{12} + 2(152 \cdot 5) \cdot \left(\frac{5}{2} + \frac{6}{2}\right)^2 + 4 \cdot \frac{5 \cdot 77^3}{12} + 4 \cdot (77 \cdot 5) \cdot \left(\frac{77}{2} + 15 + \frac{6}{2}\right)^2 + 4 \cdot \frac{9,5 \cdot 5^3}{12} + 4 \cdot (9,5 \cdot 5) \cdot \left(\frac{180}{2} + \frac{5}{2}\right)^2$$

$$I_w = 13,07 \cdot 10^6 \text{ mm}^4$$

Assessment in point 1

$$\tau_{II} = \frac{f_{v,Ed}}{2 \cdot a \cdot l} = \frac{89,99 \cdot 10^3}{2 \cdot 5 \cdot 122} = 73,76 \text{ MPa}$$

$$\tau_{\perp} = \sigma_{\perp} = \frac{1}{\sqrt{2}} \cdot \frac{F_{v,Ed} \cdot e}{\frac{I_w}{z_1}} = \frac{1}{\sqrt{2}} \cdot \frac{89,99 \cdot 10^3 \cdot \left(40 + \frac{50}{2}\right)}{\frac{13,07 \cdot 10^6}{\frac{122}{2}}}$$

$$\tau_{\perp} = \sigma_{\perp} = 19,30 \text{ MPa}$$

$$\sqrt{\sigma_{\perp}^2 + 3 \cdot (\tau_{\perp}^2 + \tau_{II}^2)} = \sqrt{19,30^2 + 3 \cdot (19,30^2 + 73,76^2)} = 133,46 \text{ MPa}$$

$$\frac{f_u}{\beta_w \cdot \gamma_{M2}} = \frac{430}{0,85 \cdot 1,25} = 404,71 \text{ MPa}$$

$$133,46 \text{ MPa} < 404,71 \text{ MPa}$$

$$\sigma_{\perp} = 19,30 \text{ MPa} < \frac{f_u \cdot 0,9}{\gamma_{M2}} = \frac{430 \cdot 0,9}{1,25} = 309,6 \text{ MPa}$$

Assessment in point 2

$$\tau_{II} = 0 \text{ MPa}$$

$$\tau_{\perp} = \sigma_{\perp} = \frac{1}{\sqrt{2}} \cdot \frac{F_{v,Ed} \cdot e}{\frac{I_w}{z_2}} = \frac{1}{\sqrt{2}} \cdot \frac{89,99 \cdot 10^3 \cdot \left(40 + \frac{50}{2}\right)}{\frac{13,07 \cdot 10^6}{\frac{181}{2}}} = 28,64 \text{ MPa}$$

$$\sqrt{\sigma_{\perp}^2 + 3 \cdot (\tau_{\perp}^2 + \tau_{II}^2)} = \sqrt{28,64^2 + 3 \cdot (28,64^2 + 0^2)} = 57,28 \text{ MPa}$$

$$57,28 \text{ MPa} < \frac{f_u}{\gamma_{M2} \cdot \beta_w} = \frac{430}{1,25 \cdot 0,85} = 404,71 \text{ MPa}$$

$$\sigma_{\perp} = 28,64 \text{ MPa} < \frac{f_u \cdot 0,9}{\gamma_{M2}} = \frac{430 \cdot 0,9}{1,25} = 309,6 \text{ MPa}$$

6.8 Welded „KK“ gap joint

DETAIL „H“

- First K joint

1) Range of validity for welded joints between CHS brace members and CHS cords

$$- \frac{d_1}{d_0} = \frac{60,3}{168,3} = 0,35 > 0,2$$

$$- \frac{d_0}{t_0} = \frac{168,3}{6} = 28,05 \rightarrow 10 < 28,05 < 50$$

$$- \frac{d_1}{t_1} = \frac{60,3}{3} = 20,1 \quad \rightarrow \quad 10 < 20,1 < 50$$

$$- \frac{d_2}{t_2} = \frac{88,9}{6} = 14,82 \quad \rightarrow \quad 10 < 14,82 < 50$$

→ gap

$$g \geq t_1 + t_2 \quad \rightarrow \quad g = 21,0 \text{ mm} > 3 + 6 = 9 \text{ mm}$$

2) Axial resistances of welded joints between CHS brace members and CHS chords

a) Chord face failure

$$N_{1,Rd} = \frac{k_g \cdot k_p \cdot f_{y0} \cdot t_0^2}{\sin \theta_1} \cdot \left(1,8 + 10,2 \cdot \frac{d_1}{d_0}\right) \cdot \mu / \gamma_{M5}$$

$$\gamma = \frac{d_0}{2 \cdot t_0} = \frac{168,3}{2 \cdot 6} = 14,03$$

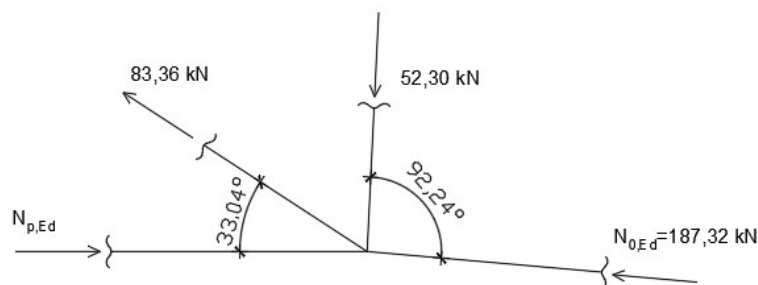

Figure 6.10. Representation of forces in beams

$$N_{p,Ed} = N_{0,Ed} - N_{1,Ed} \cdot \cos \theta_1 - N_{2,Ed} \cdot \cos \theta_2 = 187,32 - 83,36 \cdot \cos 33,04 - 52,30 \cdot \cos 92,24$$

$$N_{p,Ed} = 259,24 \text{ kN}$$

$$\sigma_{p,Ed} = \frac{N_{p,Ed}}{A_0} = \frac{259,24}{\frac{16,83^2 \cdot \pi}{4} - \frac{(16,83 - 2 \cdot 0,6)^2 \cdot \pi}{4}} = 8,47 \text{ kN/cm}^2$$

$$n_p = (\sigma_{p,Ed} / f_y) / \gamma_{M5} = (8,47 / 27,5) / 1,0 = 0,31$$

$$n_p > 0 \text{ (compression)} \rightarrow k_p = 1 - 0,3 \cdot n_p \cdot (1 + n_p) = 1 - 0,3 \cdot 0,31 \cdot (1 + 0,31)$$

$$k_p = 0,88 < 1,0$$

$$k_g = \gamma^{0,2} \cdot \left(1 + \frac{0,024 \cdot \gamma^{1,2}}{1 + e^{\left(\frac{0,5 \cdot g}{t_0} - 1,33\right)}} \right) = 14,03^{0,2} \cdot \left(1 + \frac{0,024 \cdot 14,03^{1,2}}{1 + e^{\left(\frac{0,5 \cdot 21,0}{6} - 1,33\right)}} \right)$$

$$k_g = 2,08$$

$$N_{1,Rd} = \frac{2,08 \cdot 0,88 \cdot 27,5 \cdot 0,6^2}{\sin 33,04} \cdot \left(1,8 + 10,2 \cdot \frac{88,9}{168,3} \right) \cdot 0,9/1,0$$

$$N_{1,Rd} = 215,01 \text{ kN} > N_{1,Ed} = 83,36 \text{ kN}$$

$$N_{2,Rd} = \frac{k_g \cdot k_p \cdot f_{y0} \cdot t_0^2}{\sin \theta_2} \cdot \left(1,8 + 10,2 \cdot \frac{d_2}{d_0} \right) \cdot \mu / \gamma_{M5}$$

$$\gamma = \frac{d_0}{2 \cdot t_0} = \frac{168,3}{2 \cdot 6} = 14,03$$

$$k_p = 0,88 < 1,0$$

$$k_g = 2,08$$

$$N_{2,Rd} = \frac{2,08 \cdot 0,88 \cdot 27,5 \cdot 0,6^2}{\sin 92,24} \cdot \left(1,8 + 10,2 \cdot \frac{60,3}{168,3} \right) \cdot 0,9/1,0$$

$$N_{2,Rd} = 89,03 \text{ kN} > N_{2,Ed} = 52,30 \text{ kN}$$

b) Punching shear failure

$$d_1 \leq d_0 - 2 \cdot t_0 = 168,3 - 2 \cdot 6 = 156,3 \text{ mm}$$

$$60,3 \text{ mm} < 156,3 \text{ mm}$$

$$\begin{aligned} N_{1,Rd} &= \frac{f_y}{\sqrt{3}} \cdot t_0 \cdot \pi \cdot d_1 \cdot \frac{1 + \sin \theta_1}{2 \cdot (\sin \theta_1)^2} \cdot \mu / \gamma_{M5} \\ &= \frac{27,5}{\sqrt{3}} \cdot 0,6 \cdot \pi \cdot 8,89 \cdot \frac{1 + \sin 33,04}{2 \cdot (\sin 33,04)^2} \cdot 0,9/1,0 \end{aligned}$$

$$N_{1,Rd} = 622,34 \text{ kN} > N_{1,Ed} = 83,36 \text{ kN}$$

$$\begin{aligned} N_{2,Rd} &= \frac{f_y}{\sqrt{3}} \cdot t_0 \cdot \pi \cdot d_2 \cdot \frac{1 + \sin \theta_2}{2 \cdot (\sin \theta_2)^2} \cdot \mu / \gamma_{M5} \\ &= \frac{27,5}{\sqrt{3}} \cdot 0,6 \cdot \pi \cdot 6,03 \cdot \frac{1 + \sin 92,24}{2 \cdot (\sin 92,24)^2} \cdot 0,9/1,0 \end{aligned}$$

$$N_{2,Rd} = 162,60 \text{ kN} > N_{2,Ed} = 52,30 \text{ kN}$$

c) Shear failure

$$\left(\frac{N_i \cdot \sin \theta_1}{V_{pl}}\right)^2 + \left(\frac{N_{0,gap}}{N_{pl}}\right)^2 \leq 1,0$$

$$N_{0,gap} \leq A_0 \cdot f_y \cdot \sqrt{1 - \left(\frac{N_i \cdot \sin \theta_1}{0,58 \cdot f_y \cdot A_v}\right)^2}$$

$$A_0 = \frac{16,83^2 \cdot \pi}{4} - \frac{(16,83 - 2 \cdot 0,6)^2 \cdot \pi}{4} = 30,59 \text{ cm}^2$$

$$V_{pl} = A_v \cdot \frac{f_y}{\sqrt{3}} = \frac{2}{\pi} \cdot A_0 \cdot \frac{f_y}{\sqrt{3}} = \frac{2}{\pi} \cdot 30,59 \cdot \frac{27,5}{\sqrt{3}} = 309,19 \text{ kN}$$

$$N_{pl} = A_0 \cdot f_y = 30,59 \cdot 27,5 = 841,23 \text{ kN}$$

$$N_{0,gap,1} \leq 30,59 \cdot 27,5 \cdot \sqrt{1 - \left(\frac{83,36 \cdot \sin 33,04}{0,58 \cdot 27,5 \cdot \frac{2}{\pi} \cdot 30,59}\right)^2} = 832,17 \text{ kN}$$

$$N_{0,gap,2} \leq 30,59 \cdot 27,5 \cdot \sqrt{1 - \left(\frac{52,30 \cdot \sin 92,24}{0,58 \cdot 27,5 \cdot \frac{2}{\pi} \cdot 30,59}\right)^2} = 829,23 \text{ kN}$$

$$N_{0,gap,1} = N_{0,Ed} - N_2 \cdot \cos \theta_2 = 187,32 - 52,30 \cdot \cos 92,24 = 189,36 \text{ kN}$$

$$N_{0,gap,2} = N_{0,Ed} + N_1 \cdot \cos \theta_1 = 187,32 + 83,36 \cdot \cos 33,04 = 257,20 \text{ kN}$$

$$189,36 \text{ kN} < 832,17 \text{ kN}$$

$$257,20 \text{ kN} \leq 829,23 \text{ kN}$$

$$\left(\frac{83,36 \cdot \sin 33,04}{309,19}\right)^2 + \left(\frac{189,36}{841,23}\right)^2 = 0,07 < 1,0$$

$$\left(\frac{52,30 \cdot \sin 92,24}{309,19}\right)^2 + \left(\frac{257,20}{841,23}\right)^2 = 0,12 < 1,0$$

- Second K joint

1) Range of validity for welded joints between CHS brace members and CHS cords

$$- \frac{d_1}{d_0} = \frac{60,3}{168,3} = 0,35 > 0,2$$

$$- \frac{d_0}{t_0} = \frac{168,3}{6} = 28,05 \rightarrow 10 < 28,05 < 50$$

$$- \frac{d_1}{t_1} = \frac{60,3}{3} = 20,1 \rightarrow 10 < 20,1 < 50$$

$$- \frac{d_2}{t_2} = \frac{88,9}{6} = 14,82 \rightarrow 10 < 14,82 < 50$$

→ gap

$$g \geq t_1 + t_2 \rightarrow g = 21,0 \text{ mm} > 3 + 6 = 9 \text{ mm}$$

2) Axial resistances of welded joints between CHS brace members and CHS chords

a) Chord face failure

$$N_{1,Rd} = \frac{k_g \cdot k_p \cdot f_{y0} \cdot t_0^2}{\sin \theta_1} \cdot \left(1,8 + 10,2 \cdot \frac{d_1}{d_0}\right) \cdot \mu / \gamma_{M5}$$

$$\gamma = \frac{d_0}{2 \cdot t_0} = \frac{168,3}{2 \cdot 6} = 14,03$$

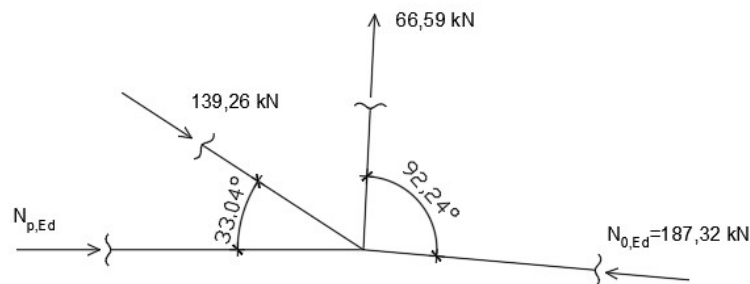

Figure 6.11. Representation of forces in beams

$$N_{p,Ed} = N_{0,Ed} - N_{1,Ed} \cdot \cos \theta_1 + N_{2,Ed} \cdot \cos \theta_2 = 187,32 - 139,26 \cdot \cos 33,04 - 66,59 \cdot \cos 92,24$$

$$N_{p,Ed} = 67,98 \text{ kN}$$

$$\sigma_{p,Ed} = \frac{N_{p,Ed}}{A_0} = \frac{67,98}{\frac{16,83^2 \cdot \pi}{4} - \frac{(16,83 - 2 \cdot 0,6)^2 \cdot \pi}{4}} = 2,22 \text{ kN/cm}^2$$

$$n_p = (\sigma_{p,Ed} / f_y) / \gamma_{M5} = (2,22 / 27,5) / 1,0 = 0,08$$

$$n_p > 0 \text{ (compression)} \rightarrow k_p = 1 - 0,3 \cdot n_p \cdot (1 + n_p) = 1 - 0,3 \cdot 0,08 \cdot (1 + 0,08)$$

$$k_p = 0,97 < 1,0$$

$$k_g = \gamma^{0,2} \cdot \left(1 + \frac{0,024 \cdot \gamma^{1,2}}{1 + e^{\left(\frac{0,5 \cdot g}{t_0} - 1,33\right)}} \right) = 14,03^{0,2} \cdot \left(1 + \frac{0,024 \cdot 14,03^{1,2}}{1 + e^{\left(\frac{0,5 \cdot 21,0}{6} - 1,33\right)}} \right)$$

$$k_g = 2,08$$

$$N_{1,Rd} = \frac{2,08 \cdot 0,97 \cdot 27,5 \cdot 0,6^2}{\sin 33,04} \cdot \left(1,8 + 10,2 \cdot \frac{88,9}{168,3} \right) \cdot 0,9/1,0$$

$$N_{1,Rd} = 236,99 \text{ kN} > N_{1,Ed} = 139,26 \text{ kN}$$

$$N_{2,Rd} = \frac{k_g \cdot k_p \cdot f_{y0} \cdot t_0^2}{\sin \theta_2} \cdot \left(1,8 + 10,2 \cdot \frac{d_2}{d_0} \right) \cdot \mu / \gamma_{M5}$$

$$\gamma = \frac{d_0}{2 \cdot t_0} = \frac{168,3}{2 \cdot 6} = 14,03$$

$$k_p = 0,97 < 1,0$$

$$k_g = 2,08$$

$$N_{2,Rd} = \frac{2,08 \cdot 0,97 \cdot 27,5 \cdot 0,6^2}{\sin 92,24} \cdot \left(1,8 + 10,2 \cdot \frac{60,3}{168,3} \right) \cdot 0,9/1,0$$

$$N_{2,Rd} = 98,13 \text{ kN} > N_{2,Ed} = 66,59 \text{ kN}$$

d) Punching shear failure

$$d_1 \leq d_0 - 2 \cdot t_0 = 168,3 - 2 \cdot 6 = 156,3 \text{ mm}$$

$$60,3 \text{ mm} < 156,3 \text{ mm}$$

$$\begin{aligned} N_{1,Rd} &= \frac{f_y}{\sqrt{3}} \cdot t_0 \cdot \pi \cdot d_1 \cdot \frac{1 + \sin \theta_1}{2 \cdot (\sin \theta_1)^2} \cdot \mu / \gamma_{M5} \\ &= \frac{27,5}{\sqrt{3}} \cdot 0,6 \cdot \pi \cdot 8,89 \cdot \frac{1 + \sin 33,04}{2 \cdot (\sin 33,04)^2} \cdot 0,9/1,0 \end{aligned}$$

$$N_{1,Rd} = 622,34 \text{ kN} > N_{1,Ed} = 139,26 \text{ kN}$$

$$N_{2,Rd} = \frac{f_y}{\sqrt{3}} \cdot t_0 \cdot \pi \cdot d_2 \cdot \frac{1 + \sin \theta_2}{2 \cdot (\sin \theta_2)^2} \cdot \mu / \gamma_{M5}$$

$$= \frac{27,5}{\sqrt{3}} \cdot 0,6 \cdot \pi \cdot 6,03 \cdot \frac{1 + \sin 92,24}{2 \cdot (\sin 92,24)^2} \cdot 0,9/1,0$$

$$N_{2,Rd} = 162,60 \text{ kN} > N_{2,Ed} = 66,59 \text{ kN}$$

e) Shear failure

$$\left(\frac{N_i \cdot \sin \theta_1}{V_{pl}} \right)^2 + \left(\frac{N_{0,gap}}{N_{pl}} \right)^2 \leq 1,0$$

$$N_{0,gap} \leq A_0 \cdot f_y \cdot \sqrt{1 - \left(\frac{N_i \cdot \sin \theta_1}{0,58 \cdot f_y \cdot A_v} \right)^2}$$

$$A_0 = \frac{16,83^2 \cdot \pi}{4} - \frac{(16,83 - 2 \cdot 0,6)^2 \cdot \pi}{4} = 30,59 \text{ cm}^2$$

$$V_{pl} = A_v \cdot \frac{f_y}{\sqrt{3}} = \frac{2}{\pi} \cdot A_0 \cdot \frac{f_y}{\sqrt{3}} = \frac{2}{\pi} \cdot 30,59 \cdot \frac{27,5}{\sqrt{3}} = 309,19 \text{ kN}$$

$$N_{pl} = A_0 \cdot f_y = 30,59 \cdot 27,5 = 841,23 \text{ kN}$$

$$N_{0,gap,1} \leq 30,59 \cdot 27,5 \cdot \sqrt{1 - \left(\frac{139,26 \cdot \sin 33,04}{0,58 \cdot 27,5 \cdot \frac{2}{\pi} \cdot 30,59} \right)^2} = 837,09 \text{ kN}$$

$$N_{0,gap,2} \leq 30,59 \cdot 27,5 \cdot \sqrt{1 - \left(\frac{66,59 \cdot \sin 92,24}{0,58 \cdot 27,5 \cdot \frac{2}{\pi} \cdot 30,59} \right)^2} = 838,05 \text{ kN}$$

$$N_{0,gap,1} = N_{0,Ed} + N_2 \cdot \cos \theta_2 = 187,32 + 66,59 \cdot \cos 92,24 = 184,72 \text{ kN}$$

$$N_{0,gap,2} = N_{0,Ed} - N_1 \cdot \cos \theta_1 = 187,32 - 139,26 \cdot \cos 33,04 = 70,58 \text{ kN}$$

$$184,72 \text{ kN} < 837,09 \text{ kN}$$

$$70,58 \text{ kN} \leq 838,05 \text{ kN}$$

$$\left(\frac{139,26 \cdot \sin 33,04}{309,19} \right)^2 + \left(\frac{184,72}{841,23} \right)^2 = 0,11 < 1,0$$

$$\left(\frac{66,59 \cdot \sin 92,24}{309,19} \right)^2 + \left(\frac{70,58}{841,23} \right)^2 = 0,05 < 1,0$$

6.9 Bracing – upper cord joint

DETAIL „I“

- Design resistances of welded joints connecting gusset plates to CHS members

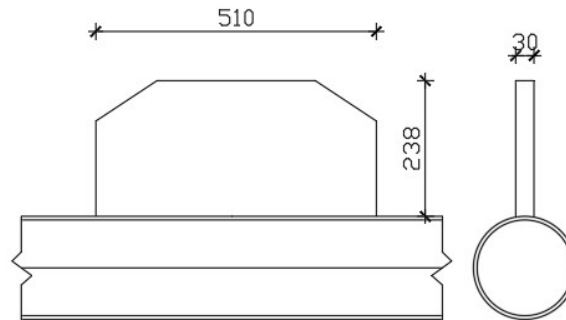

Figure 6.12. Representation of gusset plate

$$N_{1,Rd} = 5 \cdot k_p \cdot f_{y0} \cdot t_0^2 \cdot (1 + 0,25 \cdot \eta) / \gamma_{M5}$$

$$M_{ip,1,Rd} = h_1 \cdot N_{1,Rd}$$

$$M_{op,1,Rd} = 0$$

1) Punching shear failure

$$A = 3,059 \cdot 10^{-3} \text{ m}^2$$

$$W_{el} = 1,1987 \cdot 10^{-4} \text{ mm}^3$$

$$\sigma_{max} \cdot t_1 = (N_{Ed}/A + M_{Ed}/W_{el}) \cdot t_1 \leq 2 \cdot t_0 \cdot (f_{y0}/\sqrt{3}) / \gamma_{M5}$$

$$\left(\frac{66,63}{3,059 \cdot 10^{-3}} + \frac{1,77}{1,1987 \cdot 10^{-4}} \right) \cdot 30 \cdot 10^{-3} < 2 \cdot 6 \cdot 10^{-3} \cdot \frac{275 \cdot 10^3}{\sqrt{3}}$$

$$1096,43 \text{ kN/m} < 1905,26 \text{ kN/m}$$

2) Chord face failure

$$\sigma_{p,Ed} = \frac{N_{p,Ed}}{A_0} = \frac{66,63}{\frac{16,83^2 \cdot \pi}{4} - \frac{(16,83 - 2 \cdot 0,6)^2 \cdot \pi}{4}} = 2,18 \text{ kN/cm}^2$$

$$n_p = (\sigma_{p,Ed}/f_y) / \gamma_{M5} = (2,18/27,5) / 1,0 = 0,08$$

$$n_p > 0 \text{ (compression)} \rightarrow k_p = 1 - 0,3 \cdot n_p \cdot (1 + n_p) = 1 - 0,3 \cdot 0,08 \cdot (1 + 0,08)$$

$$k_p = 0,97 < 1,0$$

$$\eta = \frac{h_1}{d_0} = \frac{510}{168,3} = 3,03 < 4$$

$$N_{1,Rd} = 5 \cdot 0,97 \cdot 27,5 \cdot 0,6^2 \cdot (1 + 0,25 \cdot 3,03) / 1,0$$

$$N_{1,Rd} = 84,39 \text{ kN} > N_{Ed} = 66,63 \text{ kN}$$

$$M_{ip,1,Rd} = 0,51 \cdot 84,39 = 43,04 \text{ kNm} > M_{Ed} = 1,77 \text{ kNm}$$

- Resistance of the weld (bracing to plate)

1) For bracing 1

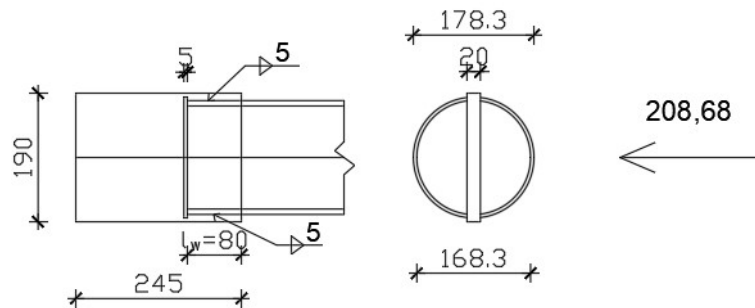

Figure 6.13. Representation of force in bracing

$$\tau_{\perp} = \sigma_{\perp} = 0 \text{ MPa}$$

$$\tau_{II} = \frac{N_{Ed}}{4 \cdot a \cdot l} = \frac{208680}{4 \cdot 5 \cdot 80} = 130,43 \text{ MPa}$$

$$130,43 \text{ MPa} \leq \frac{f_u}{\gamma_{M2} \cdot \beta_w \cdot \sqrt{3}} = \frac{430}{1,25 \cdot 0,85 \cdot \sqrt{3}} = 233,66 \text{ MPa}$$

$$\sqrt{\sigma_{\perp}^2 + 3 \cdot (\tau_{\perp}^2 + \tau_{II}^2)} = \sqrt{0^2 + 3 \cdot (0^2 + 130,43^2)} = 225,91 \text{ MPa}$$

$$225,91 \text{ MPa} < \frac{f_u}{\gamma_{M2} \cdot \beta_w \cdot \sqrt{3}} = \frac{430}{1,25 \cdot 0,85 \cdot \sqrt{3}} = 233,66 \text{ MPa}$$

1) For bracing 2

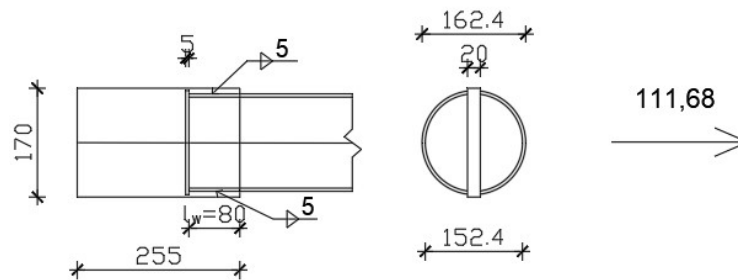

Figure 6.14. Representation of force in bracing

$$\tau_{\perp} = \sigma_{\perp} = 0 \text{ MPa}$$

$$\tau_{II} = \frac{N_{Ed}}{4 \cdot a \cdot l} = \frac{111680}{4 \cdot 5 \cdot 80} = 69,8 \text{ MPa}$$

$$69,8 \text{ MPa} \leq \frac{f_u}{\gamma_{M2} \cdot \beta_w \cdot \sqrt{3}} = \frac{430}{1,25 \cdot 0,85 \cdot \sqrt{3}} = 233,66 \text{ MPa}$$

$$\sqrt{\sigma_{\perp}^2 + 3 \cdot (\tau_{\perp}^2 + \tau_{II}^2)} = \sqrt{0^2 + 3 \cdot (0^2 + 69,8^2)} = 120,90 \text{ MPa}$$

$$120,90 \text{ MPa} < \frac{f_u}{\gamma_{M2} \cdot \beta_w \cdot \sqrt{3}} = \frac{430}{1,25 \cdot 0,85 \cdot \sqrt{3}} = 233,66 \text{ MPa}$$

- Resistance of the bolt

1) For bracing 1

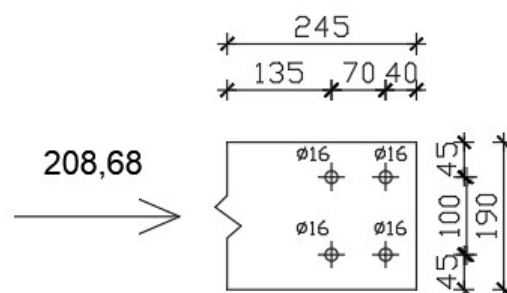

Figure 6.15. Representation of bolts in bracing

4xM16 8.8

- Resistance of the bolt in shear

$$F_{v,Rd} = 77,2 \text{ kN (from table)}$$

$$F_{v,Ed} = \frac{208,68}{4} = 52,17 \text{ kN}$$

$$\frac{F_{v,Ed}}{F_{v,Rd}} < 1,0$$

$$\frac{52,17}{77,2} = 0,68 < 1,0$$

- Resistance of the bolt in bearing

$$F_{b,Rd} = \frac{k_1 \cdot \alpha_b \cdot f_u \cdot d \cdot t}{\gamma_{M2}}$$

$$\alpha_b \rightarrow \min\left(\frac{f_{ub}}{f_u}; 1,0; \alpha_d\right)$$

$$\alpha_d = \frac{e_1}{3 \cdot d_0} = \frac{45}{3 \cdot 18} = 0,83$$

$$\frac{f_{ub}}{f_u} = \frac{800}{430} = 1,86$$

$$\rightarrow \alpha_b = 0,83$$

$$k_1 \rightarrow \min\left(2,8 \cdot \frac{e_2}{d_0} - 1,7; 1,4 \cdot \frac{p_2}{d_0} - 1,7; 2,5\right)$$

$$2,8 \cdot \frac{e_2}{d_0} - 1,7 = 2,8 \cdot \frac{40}{18} - 1,7 = 4,52$$

$$1,4 \cdot \frac{p_2}{d_0} - 1,7 = 1,4 \cdot \frac{70}{18} - 1,7 = 3,74$$

$$\rightarrow k_1 = 2,5$$

$$F_{b,Rd} = \frac{2,5 \cdot 0,83 \cdot 430 \cdot 10^{-3} \cdot 16 \cdot 20}{1,25} = 228,42 \text{ kN}$$

$$F_{v,Ed} = \frac{228,42}{4} = 57,1 \text{ kN}$$

$$\frac{57,1 \text{ kN}}{203,65 \text{ kN}} = 0,28 < 1,0$$

2) For bracing 2

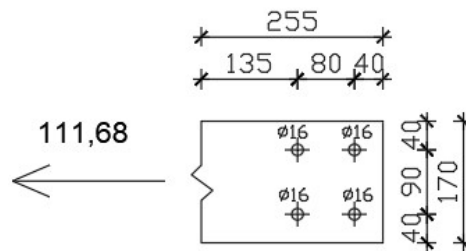

Figure 6.16. Representation of bolts in bracing

4xM16 8.8

- Resistance of the bolt in shear

$$F_{v,Rd} = 77,2 \text{ kN (from table)}$$

$$F_{v,Ed} = \frac{111,68}{4} = 27,92 \text{ kN}$$

$$\frac{F_{v,Ed}}{F_{v,Rd}} < 1,0$$

$$\frac{27,92}{77,2} = 0,36 < 1,0$$

- Resistance of the bolt in bearing

$$F_{b,Rd} = \frac{k_1 \cdot \alpha_b \cdot f_u \cdot d \cdot t}{\gamma_{M2}}$$

$$\alpha_b \rightarrow \min\left(\frac{f_{ub}}{f_u}; 1,0; \alpha_d\right)$$

$$\alpha_d = \frac{e_1}{3 \cdot d_0} = \frac{40}{3 \cdot 18} = 0,74$$

$$\frac{f_{ub}}{f_u} = \frac{800}{430} = 1,86$$

$$\rightarrow \alpha_b = 0,74$$

$$k_1 \rightarrow \min \left(2,8 \cdot \frac{e_2}{d_0} - 1,7; 1,4 \cdot \frac{p_2}{d_0} - 1,7; 2,5 \right)$$

$$2,8 \cdot \frac{e_2}{d_0} - 1,7 = 2,8 \cdot \frac{40}{18} - 1,7 = 4,52$$

$$1,4 \cdot \frac{p_2}{d_0} - 1,7 = 1,4 \cdot \frac{80}{18} - 1,7 = 4,52$$

$$\rightarrow k_1 = 2,5$$

$$F_{b,Rd} = \frac{2,5 \cdot 0,74 \cdot 430 \cdot 10^{-3} \cdot 16 \cdot 20}{1,25} = 203,65 \text{ kN}$$

$$F_{v,Ed} = \frac{111,68}{4} = 27,92 \text{ kN}$$

$$\frac{27,92 \text{ kN}}{203,65 \text{ kN}} = 0,14 < 1,0$$

6.10 Upper cord – concrete joint

DETAIL „J“

1) Resistance of the weld

$$\tau_{II} = 0 \text{ MPa}$$

$$\tau_{\perp} = \sigma_{\perp} = \frac{1}{\sqrt{2}} \cdot \frac{N_{Ed}}{a \cdot l} = \frac{1}{\sqrt{2}} \cdot \frac{107840}{5 \cdot 168,3 \cdot \pi} = 28,84 \text{ MPa}$$

$$\sqrt{\sigma_{\perp}^2 + 3 \cdot (\tau_{\perp}^2 + \tau_{II}^2)} = \sqrt{28,84^2 + 3 \cdot (28,84^2 + 0^2)} = 57,68 \text{ MPa}$$

$$57,68 \text{ MPa} < \frac{f_u}{\gamma_{M2} \cdot \beta_w} = \frac{430}{1,25 \cdot 0,85} = 404,71 \text{ MPa}$$

$$\sigma_{\perp} = 28,84 \text{ MPa} < \frac{f_u \cdot 0,9}{\gamma_{M2}} = \frac{430 \cdot 0,9}{1,25} = 309,6 \text{ MPa}$$

2) Resistance of anchor in shear

$$F_{1,vb,Rd} = \frac{\alpha_v \cdot f_{ub} \cdot A}{\gamma_{M2}}$$

$$F_{1,vb,Rd} = 120,6 \text{ kN} \rightarrow \text{from table}$$

$$F_{2,vb,Rd} = \frac{\alpha_{bc} \cdot f_{ub} \cdot A_s}{\gamma_{M2}}$$

$$A_s = 314 \text{ mm}^2$$

$$f_{ub} = 800 \text{ N/mm}^2$$

$$\alpha_{bc} = 0,44 - 0,0003 \cdot 640 = 0,25$$

$$F_{2,vb,Rd} = \frac{0,25 \cdot 800 \cdot 314}{1,25} = 50,24 \text{ kN}$$

$$\min(F_{1,vb,Rd}; F_{2,vb,Rd}) \rightarrow F_{2,vb,Rd} = 50,24 \text{ kN} > \frac{V_{Ed}}{4} = \frac{186,18}{4} = 46,55 \text{ kN}$$

3) Resistance of anchor in tension

$$F_{t,Rd} = \frac{k_2 \cdot f_{ub} \cdot A_s}{\gamma_{M2}}$$

$$F_{t,Rd} = 141,1 \text{ kN} \rightarrow \text{from table}$$

$$F_{t,Rd} = 141,1 \text{ kN} > F_{t,Ed} = \frac{N_{Ed}}{4} = \frac{107,84}{4} = 26,96 \text{ kN}$$

4) Design of anchorage length

$$h \geq \sqrt{\frac{F}{2,1 \cdot f_{ctd}}}$$

$$f_{ctd} = \alpha_{ct} \cdot f_{ctk,0.05} / \gamma_c = 1,0 \cdot 1,8 / 1,5 = 1,2$$

$$\gamma_c = 1,5$$

$$\alpha_{ct} = 1,0$$

$$f_{ctk,0.05} = 1,8$$

$$h \geq \sqrt{\frac{107,84}{2,1 \cdot 1,2}} = 0,2069 \text{ m} = 206,9 \text{ mm}$$

$$h = 210 \text{ mm}$$

6.11 Purlin – upper cord joint

DETAIL „K“

1) Resistance of the weld (UPE to Upper cord)

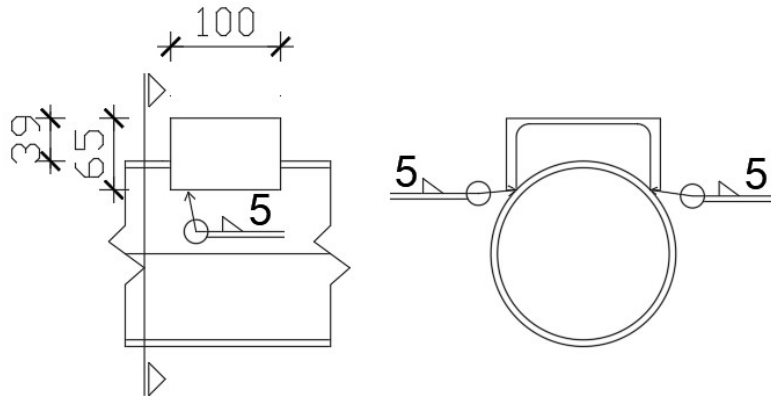

Figure 6.17. Representation of C profile on upper cord

(load parallel to weld)

$$\tau_{II} = 0 \text{ MPa}$$

$$\tau_{\perp} = \sigma_{\perp} = \frac{1}{\sqrt{2}} \cdot \frac{N_{Ed}}{a \cdot l} = \frac{1}{\sqrt{2}} \cdot \frac{273360}{2 \cdot 5 \cdot 100} = 193,29 \text{ MPa}$$

$$\sqrt{\sigma_{\perp}^2 + 3 \cdot (\tau_{\perp}^2 + \tau_{II}^2)} = \sqrt{193,29^2 + 3 \cdot (193,29^2 + 0^2)} = 386,59 \text{ MPa}$$

$$386,59 \text{ MPa} < \frac{f_u}{\gamma_{M2} \cdot \beta_w} = \frac{430}{1,25 \cdot 0,85} = 404,71 \text{ MPa}$$

$$\sigma_{\perp} = 193,29 \text{ MPa} < \frac{f_u \cdot 0,9}{\gamma_{M2}} = \frac{430 \cdot 0,9}{1,25} = 309,6 \text{ MPa}$$

2) Resistance of the weld (L plate to UPE)

(load perpendicular to weld from force)

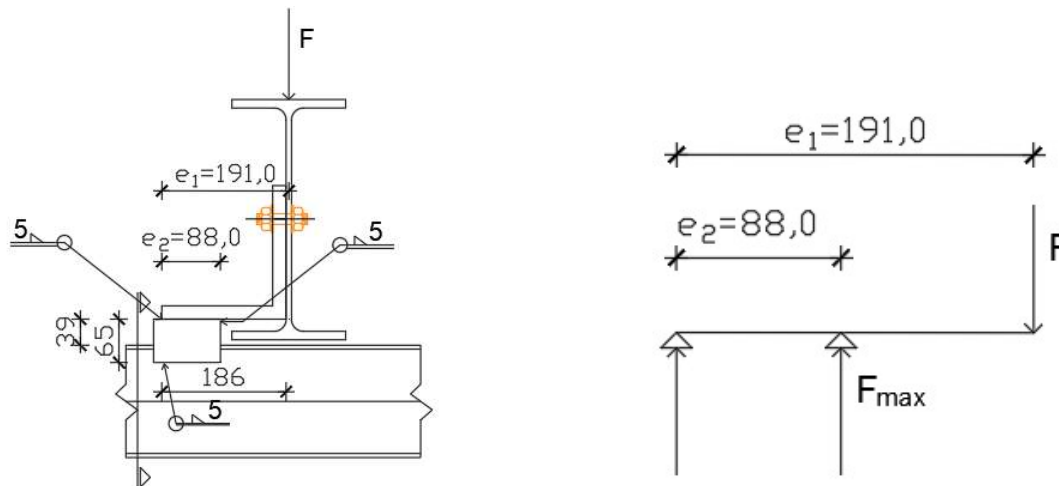

Figure 6.18. Representation of purlin to upper cord connection

$$F = 21,88 \text{ kN}$$

$$\Sigma M_A = 0$$

$$F_{max} \cdot e_2 - F \cdot e_1 = 0 \rightarrow F_{max} = \frac{F \cdot e_1}{e_2} = \frac{21,88 \cdot 0,191}{0,088}$$

$$F_{max} = 47,49 \text{ kN}$$

$$\tau_{II} = 0 \text{ MPa}$$

$$\tau_{\perp} = \sigma_{\perp} = \frac{1}{\sqrt{2}} \cdot \frac{F_{max}}{a \cdot l} = \frac{1}{\sqrt{2}} \cdot \frac{47490}{2 \cdot 5 \cdot 120} = 27,98 \text{ MPa}$$

$$\sqrt{\sigma_{\perp}^2 + 3 \cdot (\tau_{\perp}^2 + \tau_{II}^2)} = \sqrt{27,98^2 + 3 \cdot (27,98^2 + 0^2)} = 55,96 \text{ MPa}$$

$$55,96 \text{ MPa} < \frac{f_u}{\gamma_{M2} \cdot \beta_w} = \frac{430}{1,25 \cdot 0,85} = 404,71 \text{ MPa}$$

$$\sigma_{\perp} = 27,98 \text{ MPa} < \frac{f_u \cdot 0,9}{\gamma_{M2}} = \frac{430 \cdot 0,9}{1,25} = 309,6 \text{ MPa}$$

3) Resistance of the weld (L plate to UPE)

(load perpendicular to weld from moment)

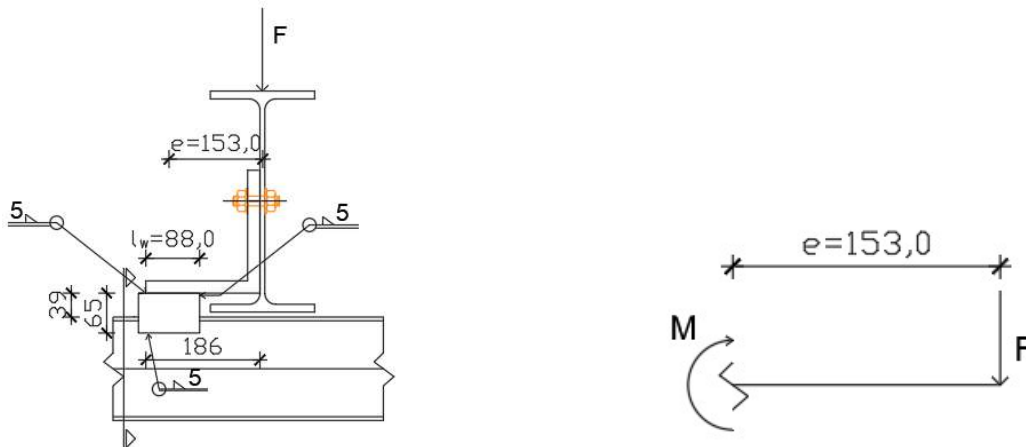

Figure 6.19. Representation of purlin to upper cord connection

$$F = 21,88 \text{ kN}$$

$$M = F \cdot e = 21,88 \cdot 0,153 = 3,35 \text{ kNm}$$

$$\tau_{II} = 0 \text{ MPa}$$

$$\tau_{\perp} = \sigma_{\perp} = \frac{1}{\sqrt{2}} \cdot \left(\frac{F}{2 \cdot a \cdot l} + \frac{M}{2 \cdot \frac{1}{6} \cdot a \cdot l} \right) = \frac{1}{\sqrt{2}} \cdot \left(\frac{21880}{2 \cdot 5 \cdot 88} + \frac{3350000}{2 \cdot \frac{1}{6} \cdot 5 \cdot 88^2} \right) = 201,11 \text{ MPa}$$

$$\sqrt{\sigma_{\perp}^2 + 3 \cdot (\tau_{\perp}^2 + \tau_{II}^2)} = \sqrt{201,11^2 + 3 \cdot (201,11^2 + 0^2)} = 402,22 \text{ MPa}$$

$$402,22 \text{ MPa} < \frac{f_u}{\gamma_{M2} \cdot \beta_w} = \frac{430}{1,25 \cdot 0,85} = 404,71 \text{ MPa}$$

$$\sigma_{\perp} = 201,11 \text{ MPa} < \frac{f_u \cdot 0,9}{\gamma_{M2}} = \frac{430 \cdot 0,9}{1,25} = 309,6 \text{ MPa}$$

4) Resistance of the bolt in shear

2xM16 8.8

$$F_{v,Rd} = 77,2 \text{ kN (from table)}$$

$$F_{v,Ed} = \frac{92,64}{2} = 46,32 \text{ kN}$$

$$\frac{F_{v,Ed}}{F_{v,Rd}} < 1,0$$

$$\frac{46,32}{77,2} = 0,36 < 1,0$$

5) Resistance of the bolt in bearing

$$F_{b,Rd} = \frac{k_1 \cdot \alpha_b \cdot f_u \cdot d \cdot t}{\gamma_{M2}}$$

$$\alpha_b \rightarrow \min\left(\frac{f_{ub}}{f_u}; 1,0; \alpha_d\right)$$

$$\alpha_d = \frac{e_1}{3 \cdot d_0} = \frac{40}{3 \cdot 18} = 0,74$$

$$\frac{f_{ub}}{f_u} = \frac{800}{430} = 1,86$$

$$\rightarrow \alpha_b = 0,74$$

$$k_1 \rightarrow \min\left(2,8 \cdot \frac{e_2}{d_0} - 1,7; 1,4 \cdot \frac{p_2}{d_0} - 1,7; 2,5\right)$$

$$2,8 \cdot \frac{e_2}{d_0} - 1,7 = 2,8 \cdot \frac{30}{18} - 1,7 = 2,96$$

$$1,4 \cdot \frac{p_2}{d_0} - 1,7 = 1,4 \cdot \frac{55}{18} - 1,7 = 2,57$$

$$\rightarrow k_1 = 2,5$$

$$F_{b,Rd} = \frac{2,5 \cdot 0,74 \cdot 430 \cdot 10^{-3} \cdot 16 \cdot 8}{1,25} = 81,46 \text{ kN}$$

$$F_{v,Ed} = \frac{92,64}{2} = 46,32 \text{ kN}$$

$$\frac{46,32 \text{ kN}}{81,46 \text{ kN}} = 0,57 < 1,0$$

7. Technical drawings

7.1. Floor plan of the construction (1:200)

7.2. Elevations of the construction (1:100)

7.3. Detail of sports hall frame (1:100)

7.4. Column bases connections (1:20)

7.5. Details of connections (1:10)

8. Literature

- (1) *Ing. Zdenek Sokol, Ph.D.: Steel Structures 1, tables; ČESKE VYSOKE UČENI TECHNICKE V PRAZE, Fakulta stavebni*
- (2) EN 1990 (2002) (English): Eurocode - Basis of structural design [Authority: The European Union Per Regulation 305/2011, Directive 98/34/EC, Directive 2004/18/EC]
- (3) EN 1991-1-1 (2002) (English): Eurocode 1: Actions on structures - Part 1-1: General actions - Densities, self-weight, imposed loads for buildings [Authority: The European Union Per Regulation 305/2011, Directive 98/34/EC, Directive 2004/18/EC]
- (4) EN 1991-1-4 (2005) (English): Eurocode 1: Actions on structures - Part 1-4: General actions - Wind actions [Authority: The European Union Per Regulation 305/2011, Directive 98/34/EC, Directive 2004/18/EC]
- (5) EN 1991-1-3 (2003) (English): Eurocode 1: Actions on structures - Part 1-3: General actions - Snow loads [Authority: The European Union Per Regulation 305/2011, Directive 98/34/EC, Directive 2004/18/EC]
- (6) EN 1993-1-1 (2005) (English): Eurocode 3: Design of steel structures - Part 1-1: General rules and rules for buildings [Authority: The European Union Per Regulation 305/2011, Directive 98/34/EC, Directive 2004/18/EC]
- (7) EN 1993-1-8 (2005) (English): Eurocode 3: Design of steel structures - Part 1-8: Design of joints [Authority: The European Union Per Regulation 305/2011, Directive 98/34/EC, Directive 2004/18/EC]

Used computer programs:

1. AutoCad 2018
2. Scia Engineering 19.1
3. Microsoft word

FLOOR PLAN OF THE CONSTRUCTION

MJ 1:200

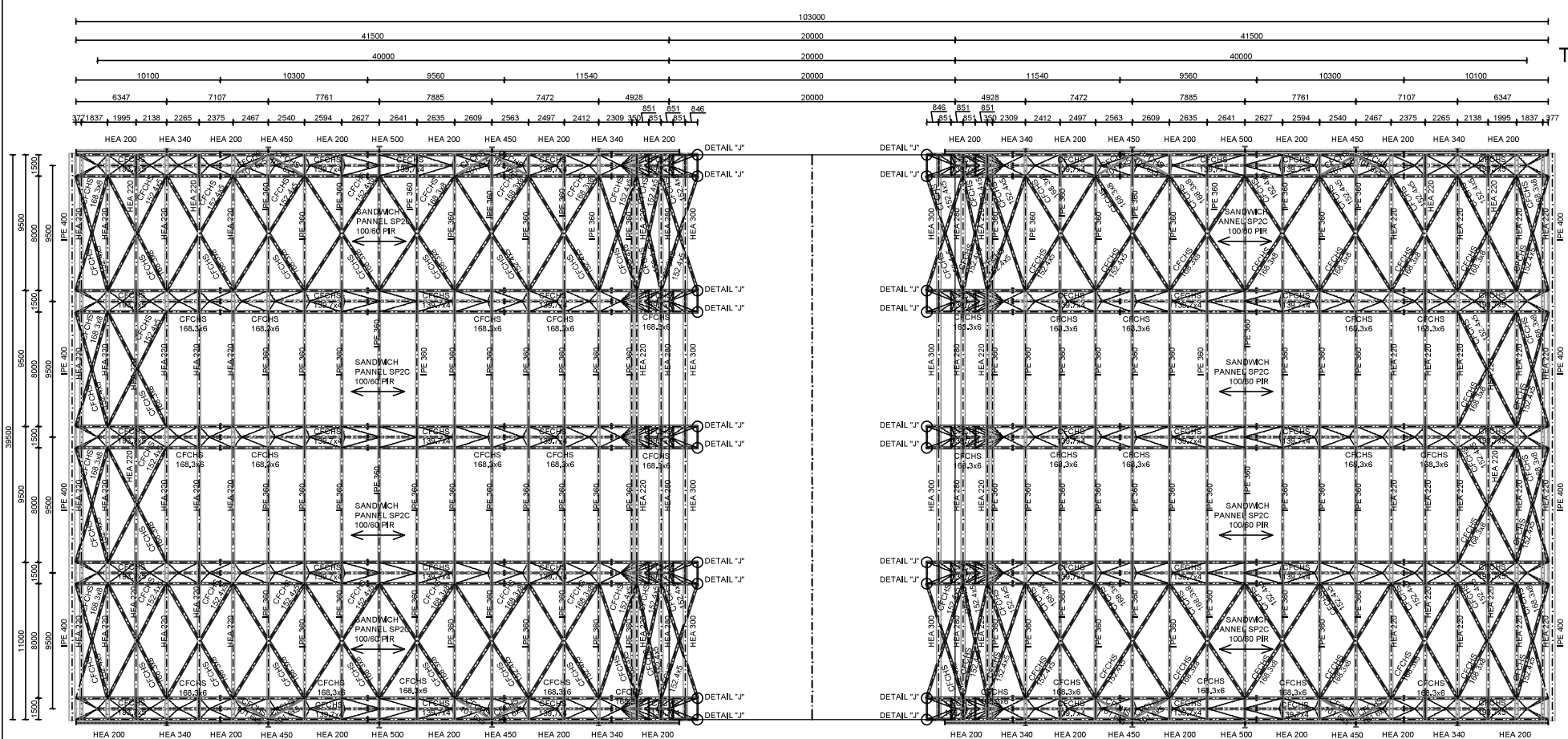

	SUPERVISOR:	ING. MICHAEL JANDELA, Ph.D. ING. VLADIMIR ČIVIC, Ph.D.	SCALE:	1:200
	THEME OF PROJECT:	Sports hall	DATE:	September 2020.
	TITLE OF APPENDIX:	Floor plan of the construction	NUMBER OF PROJECT:	34019A
			STUDENT:	Antonín Periš
			NUMBER:	1

ELEVATION OF THE CONSTRUCTION

MJ 1:100

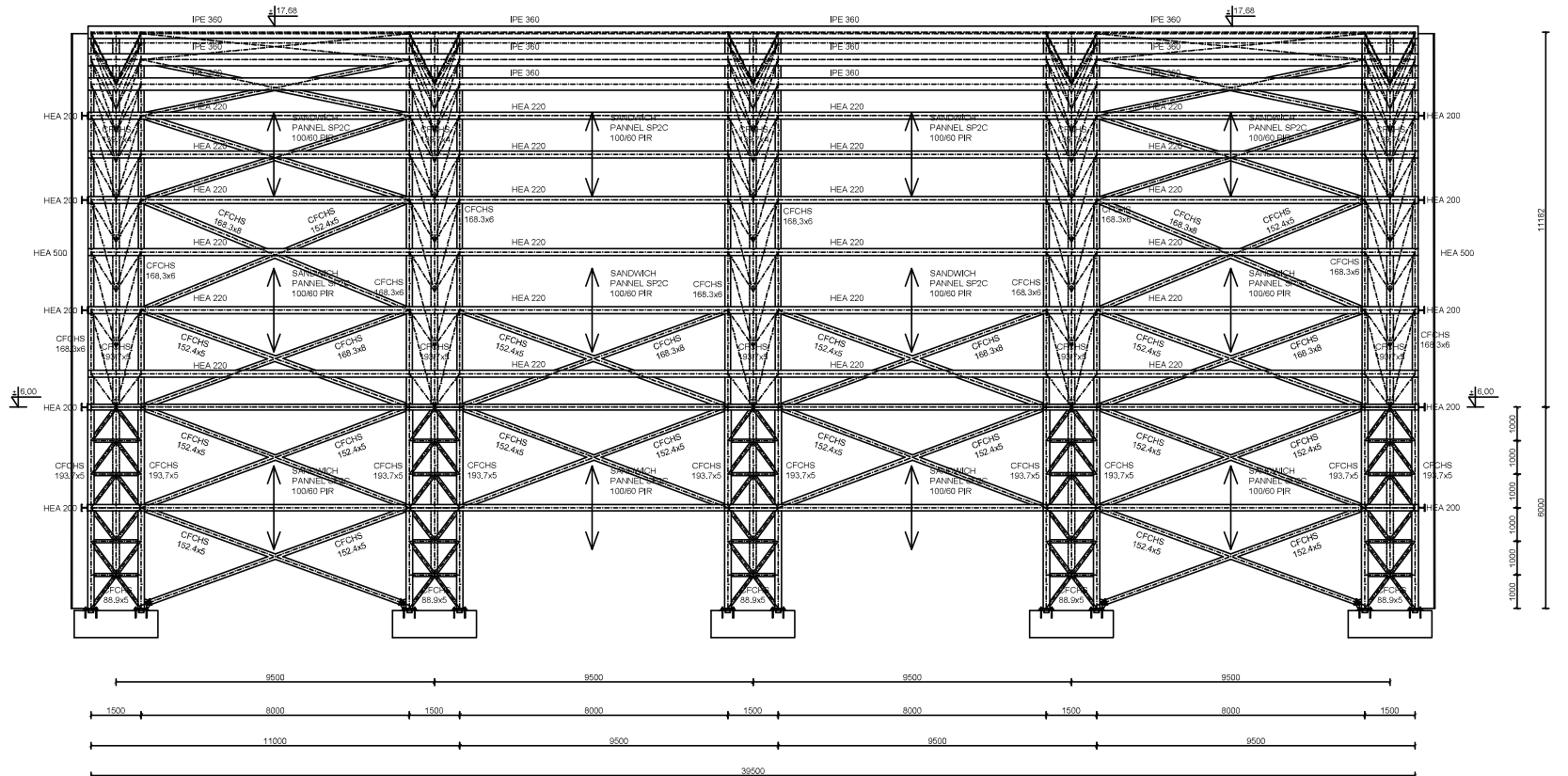

	SUPERVISOR:	ING. MICHAL JANDERA, Ph.D. ING. VLADIMIR CIVIC, Ph.D.	SCALE:	1:100
	THEME OF PROJECT:	Sports hall	DATE:	September 2020,
	TITLE OF APPROPRIATION:	elevation of the construction	NUMBER OF PROJECT:	340/19-A
			STUDENT:	Antonio Peris
			NUMBER:	2

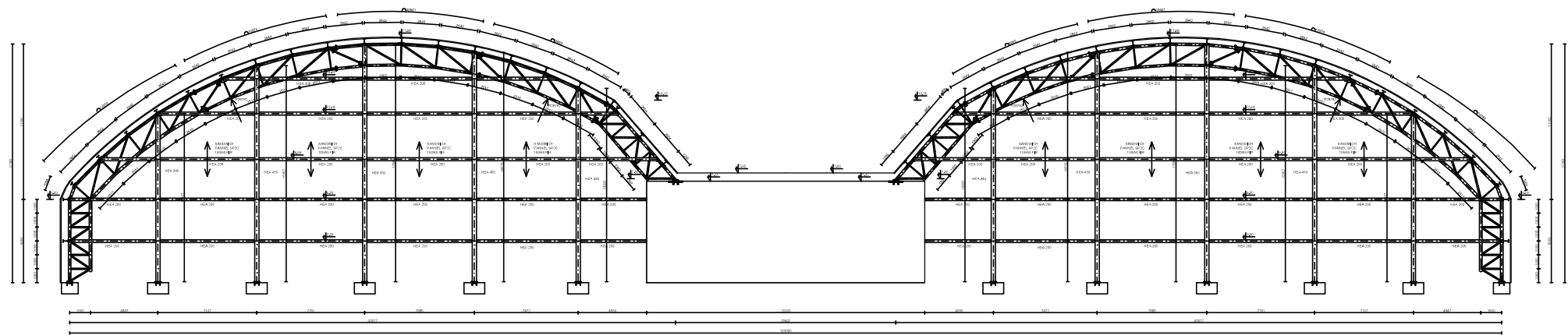

ELEVATION OF THE CONSTRUCTION MJ 1:100

	Projektant: Inżynier Inżynier Inżynier Inżynier	Data: 2024-01-01
	Tytuł: Budowa	Skala: 1:100
Projektant: Inżynier Inżynier	Inżynier Inżynier	Inżynier Inżynier
Inżynier Inżynier	Inżynier Inżynier	Inżynier Inżynier

DETAIL OF SPORTS
HALL FRAME
MJ 1:100

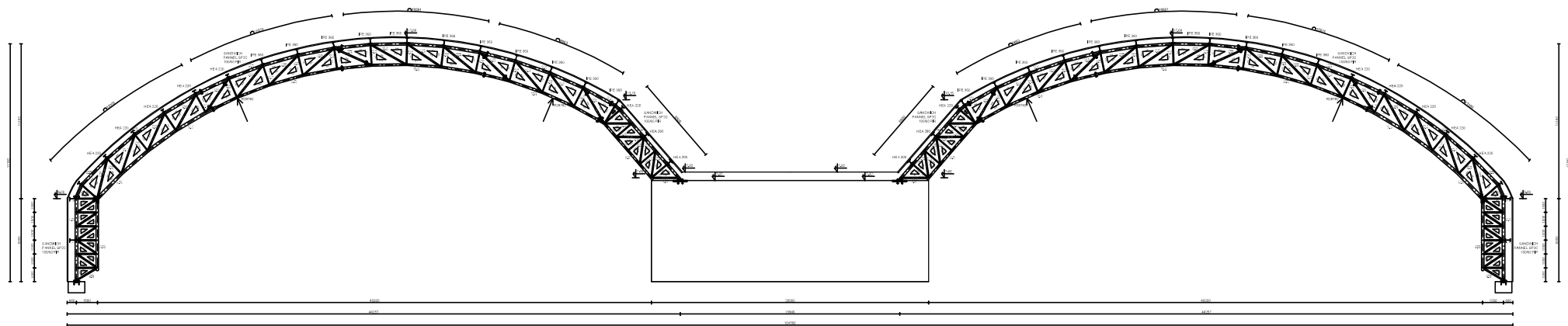

	STAINLESS STEEL	100
	CONCRETE	200
	WOOD	100
	GLASS	100
	INSULATION	100

JOINT FOUNDATION-COLUMN GRID DETAIL "A" MJ 1:20

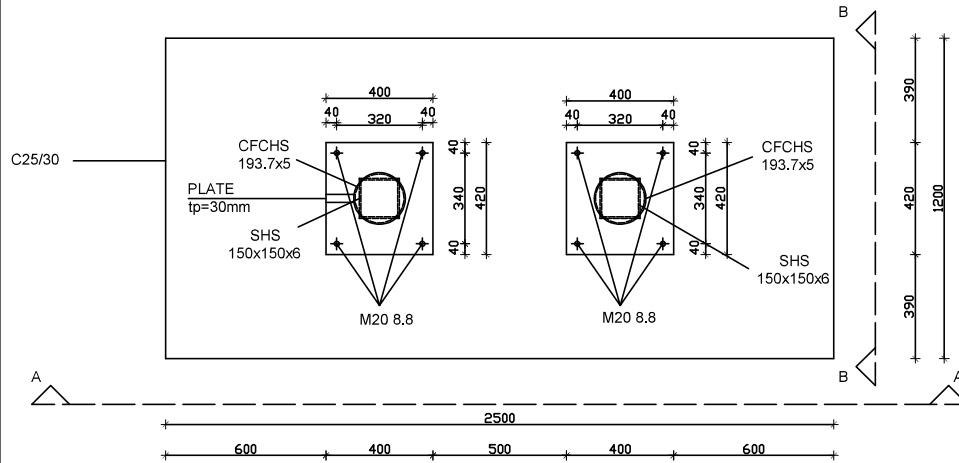

Plate 400x400x30

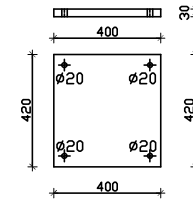
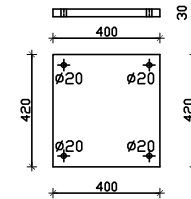
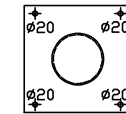
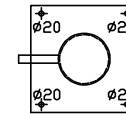

Plate 400x400x30



SECTION C-C



SECTION A-A

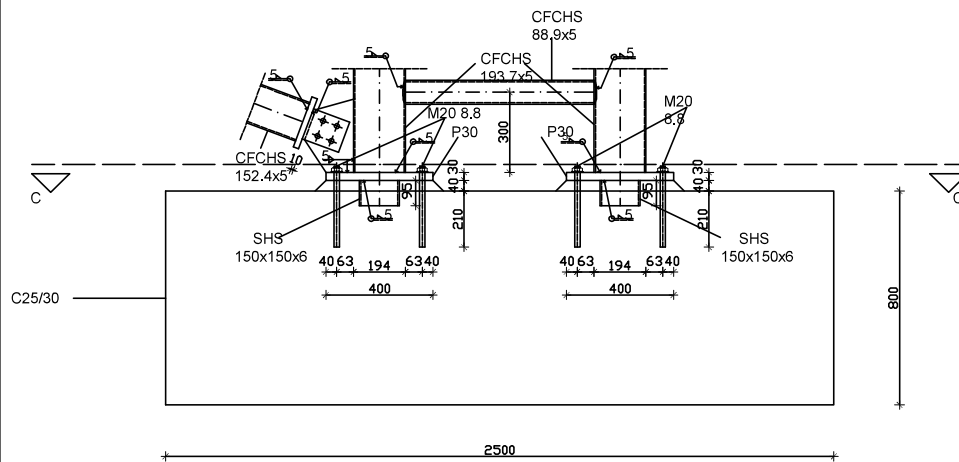

SECTION B-B

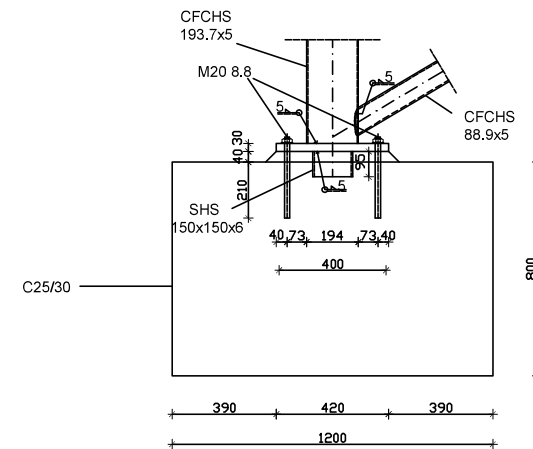

STEEL: S275
BOLTS: M20, 8.8
CONCRETE C25/30
CLASS PERFORMED EXC2

	SUPERVISOR: ING. MICHAL JANDERA; Ph.D. ING. VLADIMIR DIMIĆ; Ph.D.	SCALE: 1:20
	THEME OF PROJECT: Sports hall	DATE: september 2020.
	TITLE OF APPENDIX: foundation-column grid joint	NUMBER OF PROJECT: 340/19-A
		STUDENT: Antonio Perić NUMBER: 5

UPPER CORD CONNECTION DETAIL "B" MJ 1:10

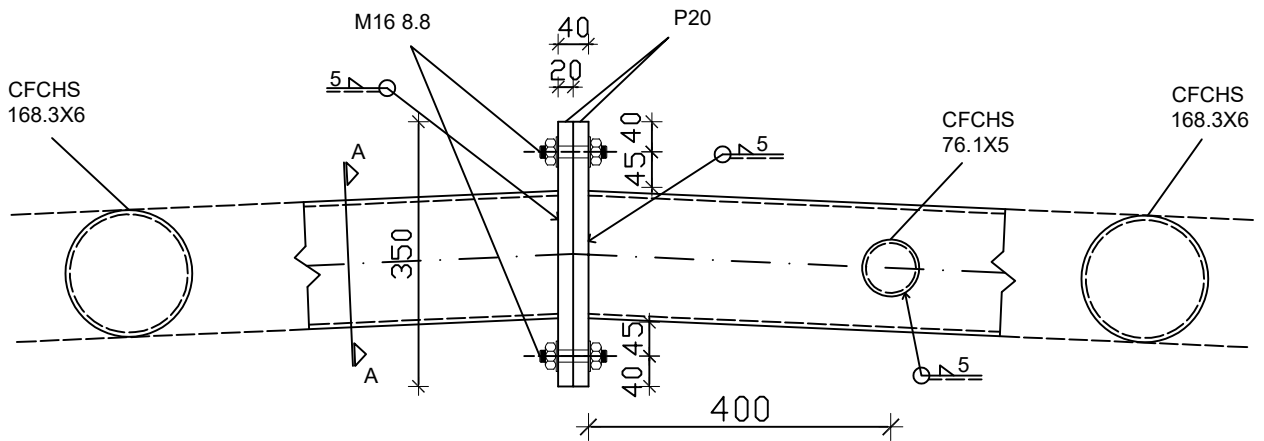
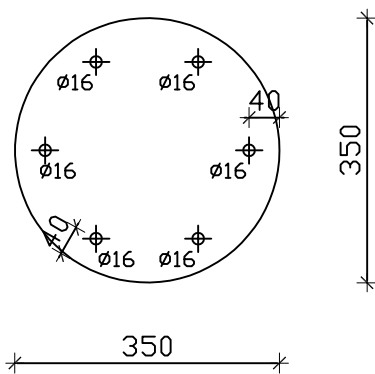
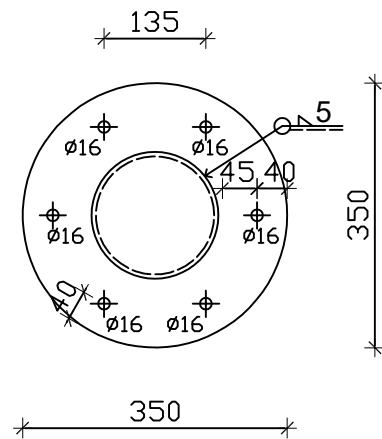

Plate Ø300x20 mm



SECTION A-A



STEEL: S275
BOLTS: M16, 8.8
CLASS PERFORMED EXC2



UNIVERSITY OF SPLIT
FACULTY OF CIVIL ENGINEERING, ARCHITECTURE
AND GEODESY
21000 SPLIT, MATICE HRVATSKE 15
IBP 2140402, tlc + 385 (0)21 302020, fax + 385 (0)21 401117

SUPERVISOR:
ING. MICHAL JANDERA; Ph.D.
ING. VLADIMIR DIVIĆ; Ph.D.

THEME OF PROJECT:
Sports hall

TITLE OF APPENDIX:
upper cord connection

SCALE:
1:10

DATE:
september 2020.

NUMBER OF PROJECT:
340/19-A

STUDENT:
Antonio Perić

NUMBER:
6

LOWER CORD CONNECTION DETAIL "C" MJ 1:10

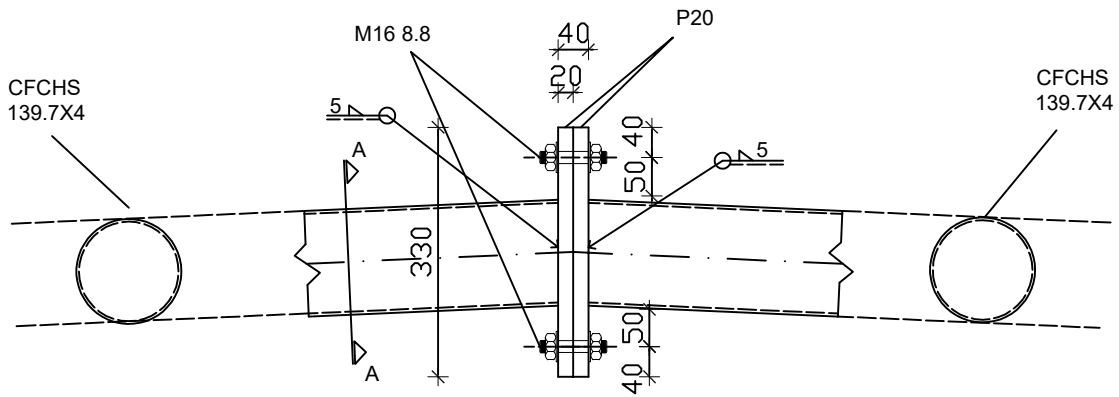
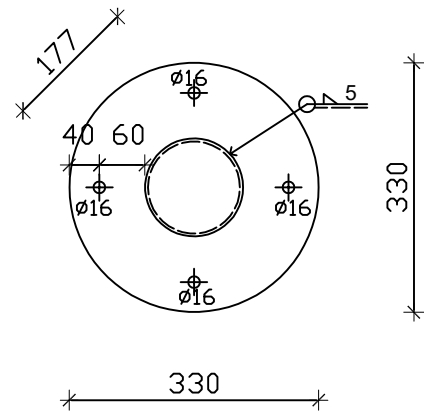
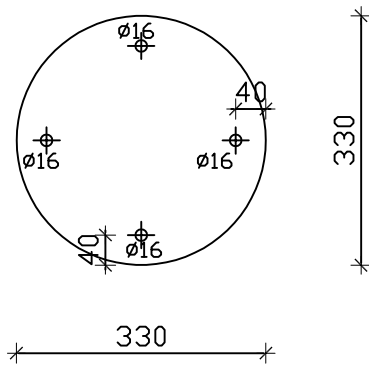

Plate Ø330x20 mm

SECTION A-A



STEEL: S275

BOLTS: M16, 8.8

CLASS PERFORMED EXC2



UNIVERSITY OF SPLIT
FACULTY OF CIVIL ENGINEERING, ARCHITECTURE
AND GEODESY
21000 SPLIT, MATICE HRVATSKE 15
tlf: 385 (0)21 300000, fax: 385 (0)21 401117

SUPERVISOR:
ING. MICHAL JANDERA; Ph.D.
ING. VLADIMIR DIVIĆ; Ph.D.

THEME OF PROJECT:
Sports hall

TITLE OF APPENDIX:
lower cord connection

SCALE:
1:10

DATE:
september 2020.

NUMBER OF PROJECT:
340/19-A

STUDENT:
Antonio Perić

NUMBER:
7

DIAGONAL CORD CONNECTION

DETAIL "D"

MJ 1:10

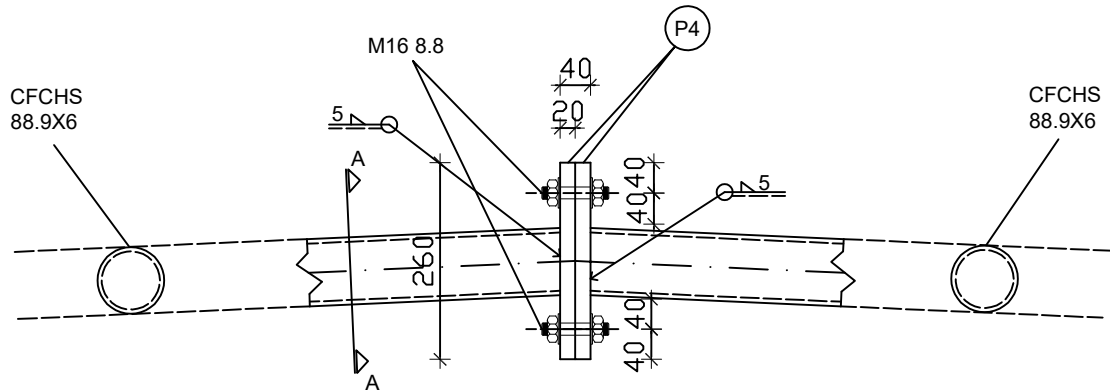
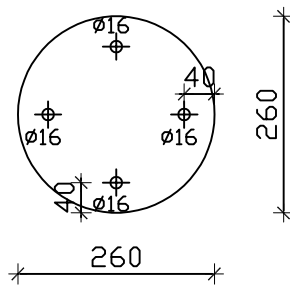
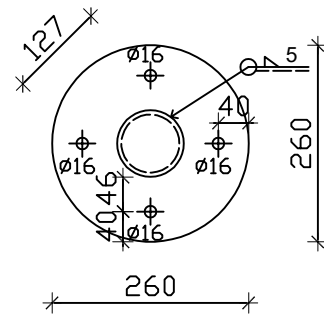

Plate Ø260x20 mm



SECTION A-A



STEEL: S275

BOLTS: M16, 8.8

CLASS PERFORMED EXC2



UNIVERSITY OF SPLIT
FACULTY OF CIVIL ENGINEERING, ARCHITECTURE
AND GEODESY
21000 SPLIT, MATICE HRVATSKE 15
tlf: 385 (0)21 302030, fax: 385 (0)21 489117

SUPERVISOR:
ING. MICHAL JANDERA; Ph.D.
ING. VLADIMIR DIVIĆ; Ph.D.

THEME OF PROJECT:
Sports hall

TITLE OF APPENDIX:
diagonal cord connection

SCALE:
1:10

DATE:
september 2020.

NUMBER OF PROJECT:
340/19-A

STUDENT:
Antonio Perić

NUMBER:
8

WELDED "N" GAP JOINT DETAIL "E" MJ 1:10

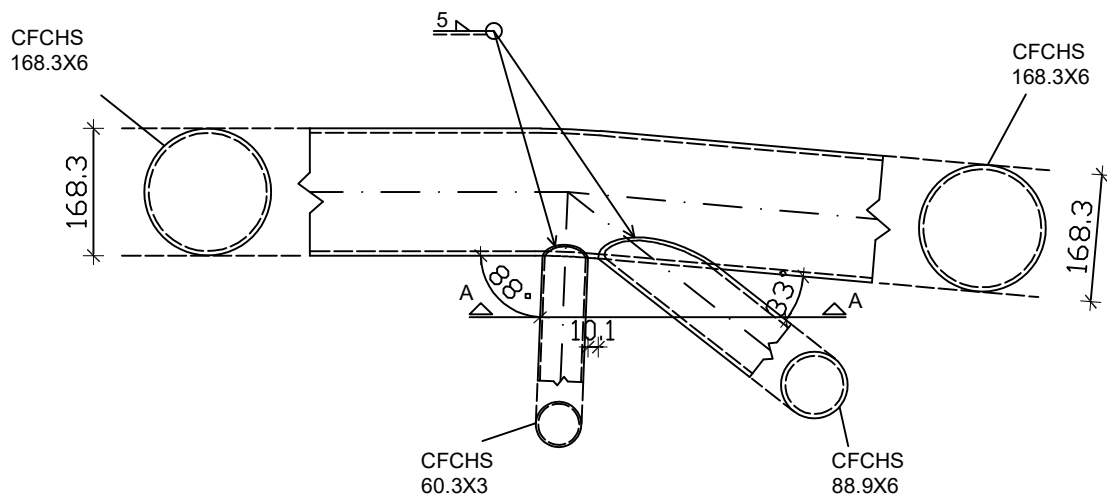

SECTION A-A

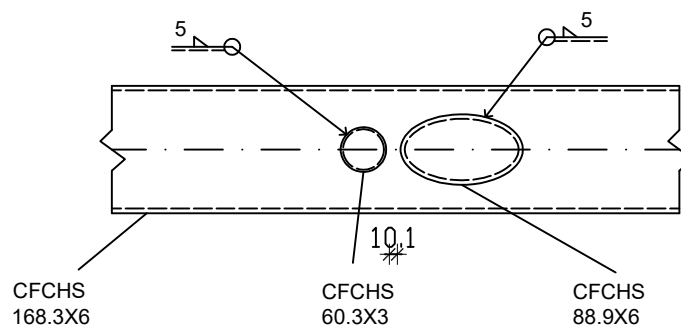

STEEL: S275

CLASS PERFORMED EXC2

 <small>UNIVERSITY OF SPLIT FACULTY OF CIVIL ENGINEERING, ARCHITECTURE AND GEODESY 21000 SPLIT, MATICE HRVATSKE 15 tlf +385 (0)21 360202, fax +385 (0)21 480117</small>	SUPERVISOR: ING. MICHAL JANDERA; Ph.D. ING. VLADIMIR DIVIĆ; Ph.D.	SCALE: 1:10
	THEME OF PROJECT: Sports hall	DATE: september 2020.
	TITLE OF APPENDIX: welded "N" gap joint	NUMBER OF PROJECT: 340/19-A
		STUDENT: Antonio Perić
		NUMBER: 9

WELDED "KT" GAP JOINT DETAIL "F" MJ 1:10

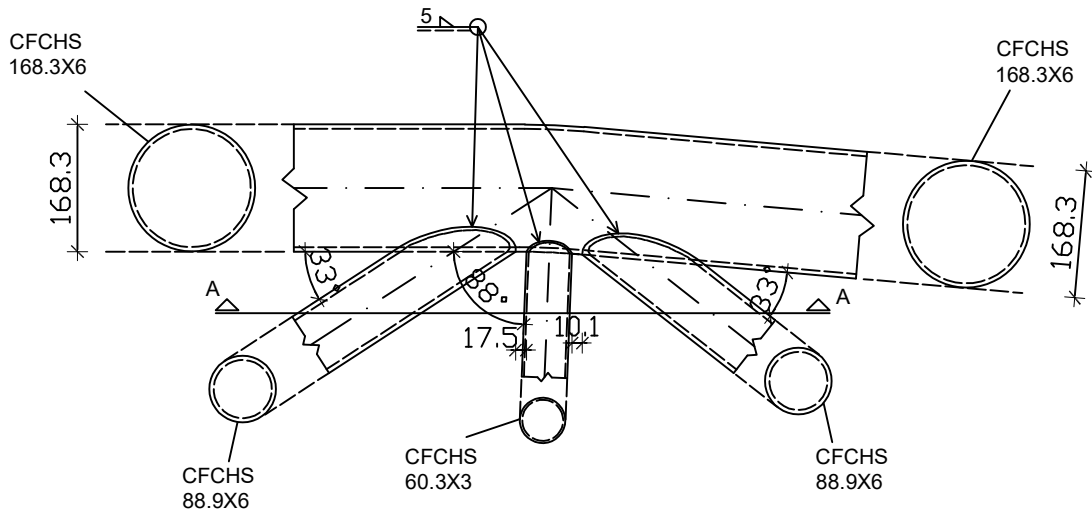

SECTION A-A

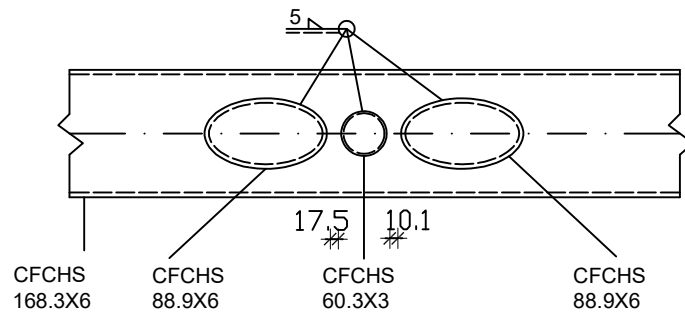

STEEL: S275

CLASS PERFORMED EXC2

 <small>UNIVERSITY OF SPLIT FACULTY OF CIVIL ENGINEERING, ARCHITECTURE AND GEODESY 21000 SPLIT, MATICE HRVATSKE 15 tlf +385 (0)21 308200; fax +385 (0)21 480117</small>	SUPERVISOR: ING. MICHAL JANDERA; Ph.D. ING. VLADIMIR DIVIĆ; Ph.D.	SCALE: 1:10
	THEME OF PROJECT: Sports hall	DATE: september 2020.
	TITLE OF APPENDIX: welded "KT" gap joint	NUMBER OF PROJECT: 340/19-A
		STUDENT: Antonio Perić
		NUMBER: 10

JOINT FOUNDATION- GABLE COLUMN DETAIL "G" MJ 1:20

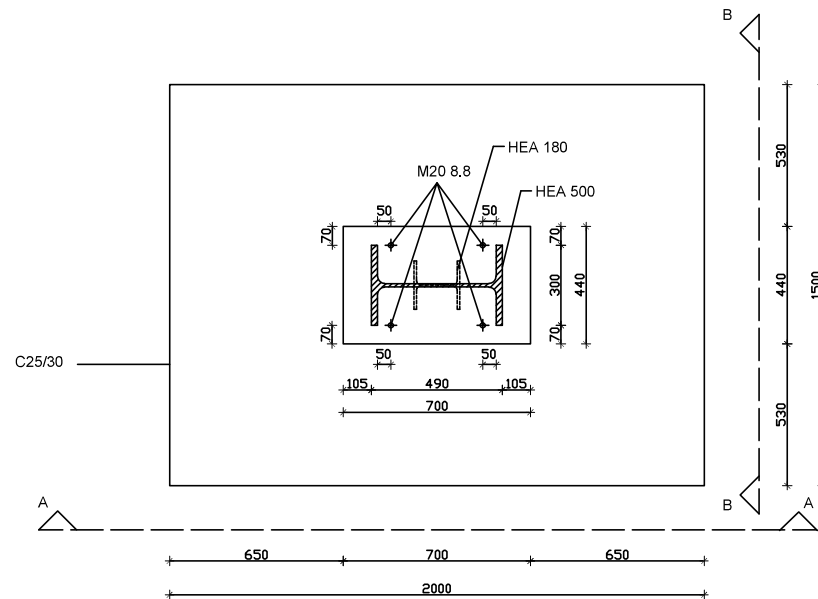

SECTION A-A

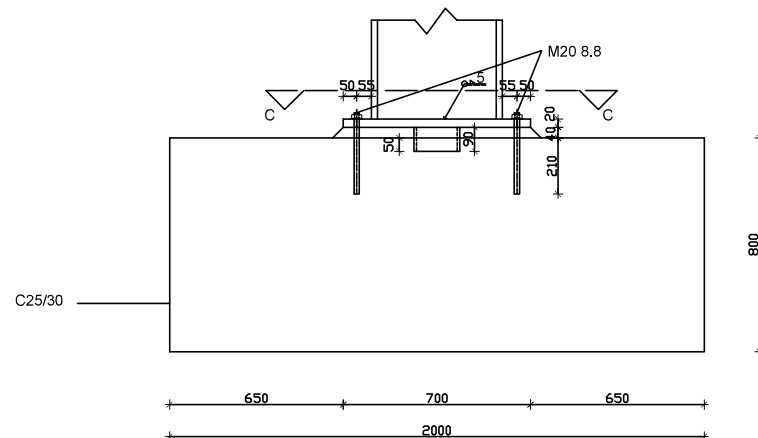
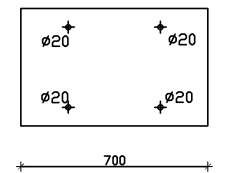
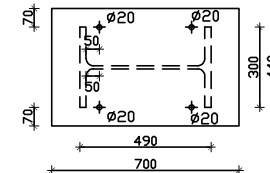

Plate 700x440x30



SECTION C-C



SECTION B-B

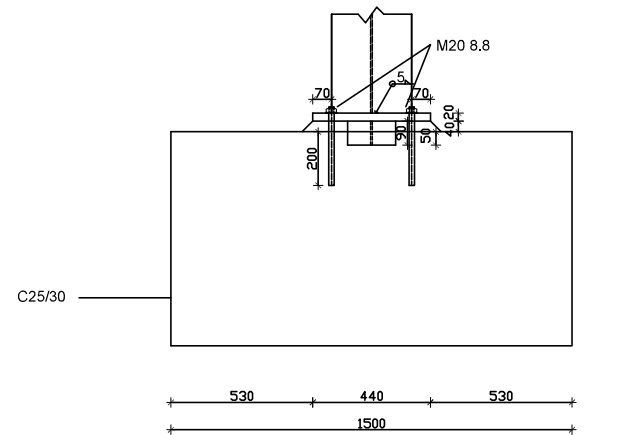

STEEL: S275
BOLTS: M20, 8.8
CONCRETE C25/30
CLASS PERFORMED EXC2

<p>UNIVERSITY OF SPLIT FACULTY OF CIVIL ENGINEERING AND ARCHITECTURE AND NOBILITY 31000 SPLIT, MATIJE KRATUŠIĆA 15 01/03/2018-2018/2019, 01/03/2018, 01/03/2019</p>	SUPERVISOR: ING. MICHAL JANDERA; Ph.D. ING. VLADIMIR DIMIĆ; Ph.D.	SCALE: 1:20
	THEME OF PROJECT: Sports hall	DATE: september 2020.
	TITLE OF APPENDIX: foundation - gable column joint	NUMBER OF PROJECT: 340/19-A
		STUDENT: Antonio Perić NUMBER: 11

WELDED "KK" GAP JOINT DETAIL "H" MJ 1:10

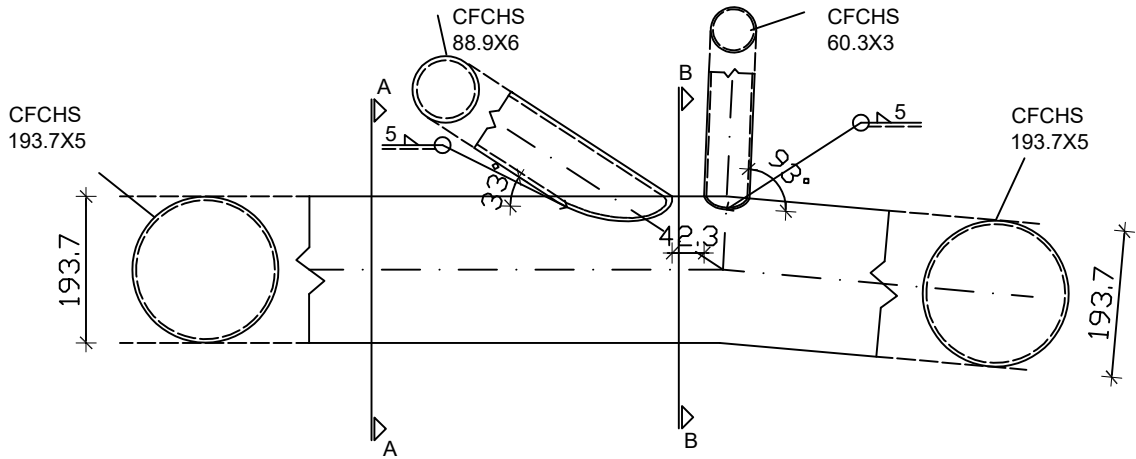

SECTION A-A

SECTION A-A

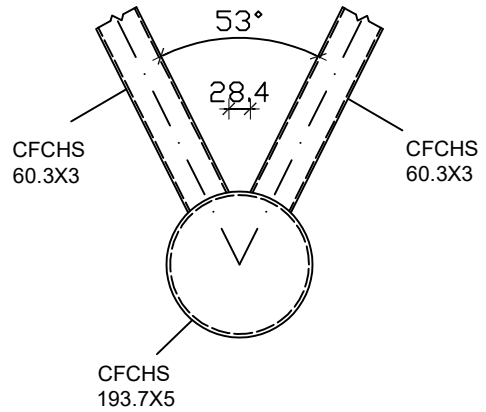
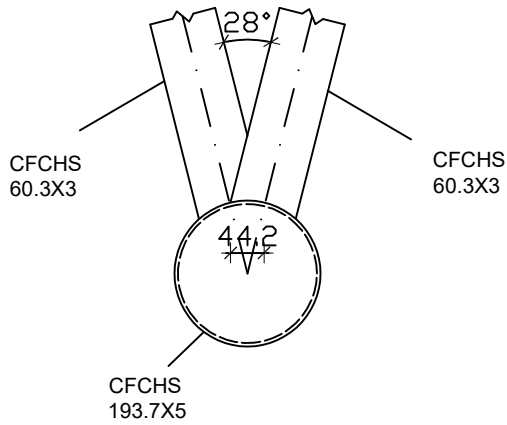

STEEL: S275

CLASS PERFORMED EXC2

 <small>UNIVERSITY OF SPLIT FACULTY OF CIVIL ENGINEERING, ARCHITECTURE AND GEODESY 21000 SPLIT, MATICE HRVATSKE 15 tlf +385 (0)21 360200, fax +385 (0)21 480117</small>	SUPERVISOR: ING. MICHAL JANDERA; Ph.D. ING. VLADIMIR DIVIĆ; Ph.D.	SCALE: 1:10
	THEME OF PROJECT: Sports hall	DATE: september 2020.
	TITLE OF APPENDIX: welded "KK" gap joint	NUMBER OF PROJECT: 340/19-A
		STUDENT: Antonio Perić
		NUMBER: 12

JOINT BRACING - UPPER CORD DETAIL "I" MJ 1:10

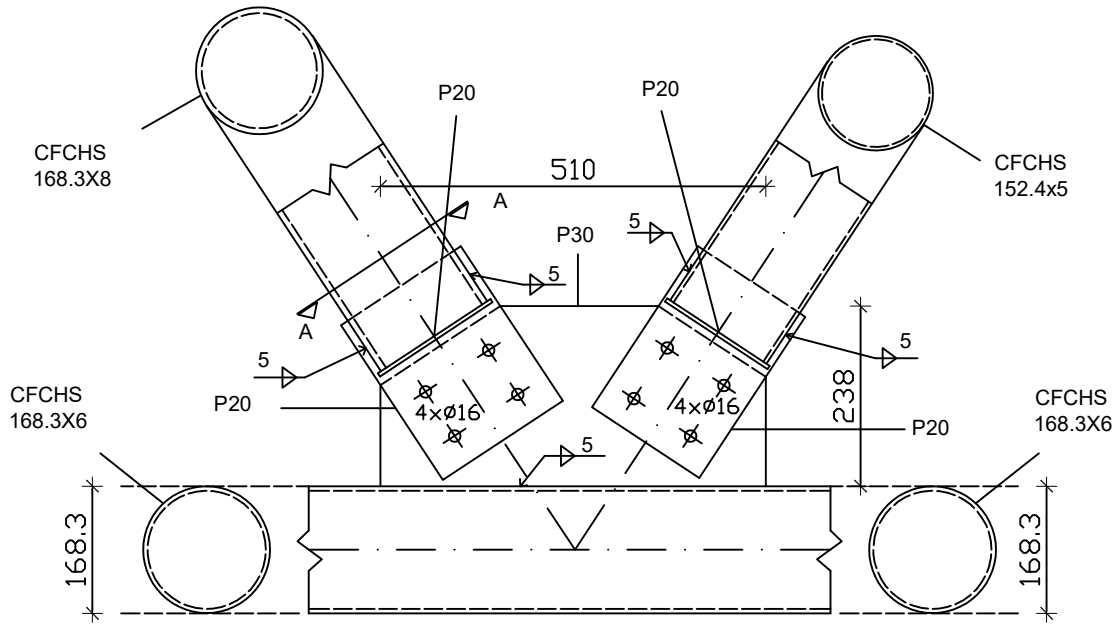

SECTION A-A

SECTION B-B

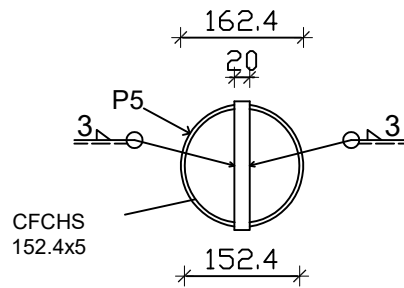
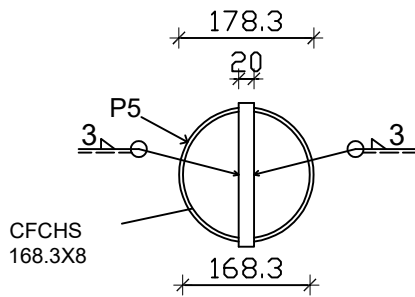
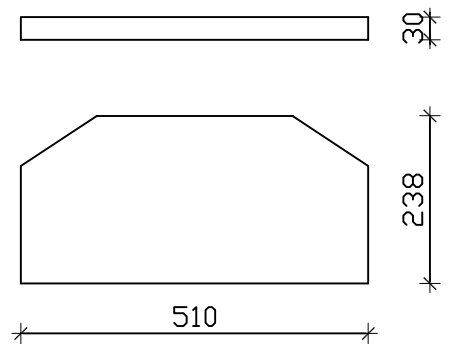
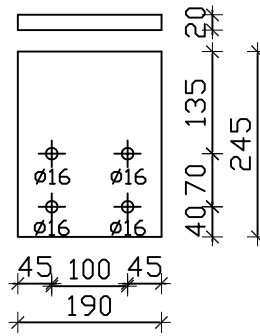
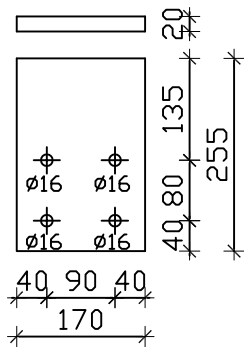

Plate 170x255x20

Plate 190x245x20

Plate



STEEL: S275

BOLTS: M16, 8.8

CLASS PERFORMED EXC2



UNIVERSITY OF SPLIT
FACULTY OF CIVIL ENGINEERING, ARCHITECTURE
AND GEODESY
21000 SPLIT, MATICE HRVATSKE 15
tlf: 051 46022, fax: 051 46021 30020, e-mail: 051 46017

SUPERVISOR:
ING. MICHAL JANDERA; Ph.D.
ING. VLADIMIR DIVIĆ; Ph.D.

THEME OF PROJECT:
Sports hall

TITLE OF APPENDIX:
bracing - upper cord joint

SCALE:
1:10

DATE:
september 2020.

NUMBER OF PROJECT:
340/19-A

STUDENT:
Antonio Perić

NUMBER:
13

JOINT UPPER CORD - CONCRETE DETAIL "J" MJ 1:10

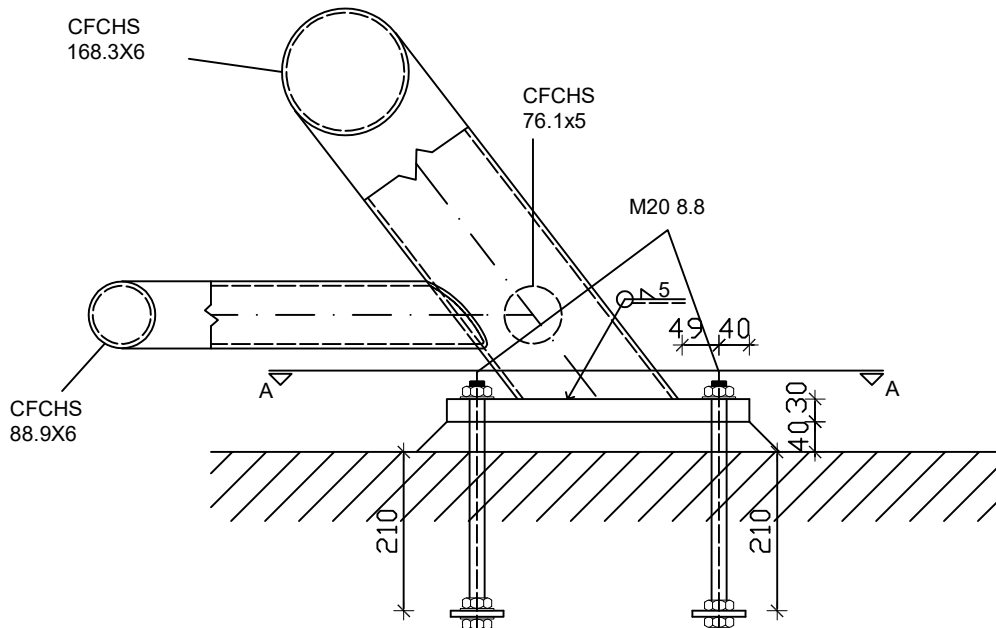

P6 400x400x30

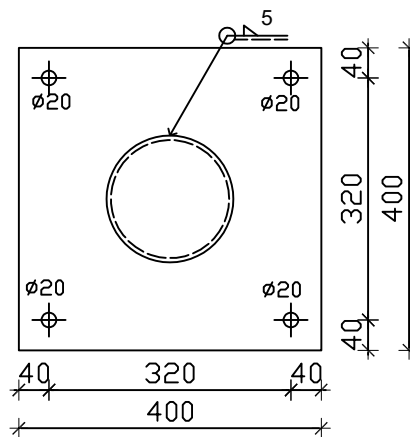

STEEL: S275
BOLTS: M20, 8.8
CONCRETE C25/30
CLASS PERFORMED EXC2



UNIVERSITY OF SPLIT
FACULTY OF CIVIL ENGINEERING, ARCHITECTURE
AND GEODESY
21000 SPLIT, MATICE HRVATSKE 15
tlf: +385 (0)21 302020, fax: +385 (0)21 409117

SUPERVISOR:
ING. MICHAL JANDERA; Ph.D.
ING. VLADIMIR DIVIĆ; Ph.D.

THEME OF PROJECT:
Sports hall

TITLE OF APPENDIX:
upper cord - concrete joint

SCALE:
1:10

DATE:
september 2020.

NUMBER OF PROJECT:
340/19-A

STUDENT:
Antonio Perić

NUMBER:
14

JOINT PURLIN - UPPER CORD DETAIL "K" MJ 1:10

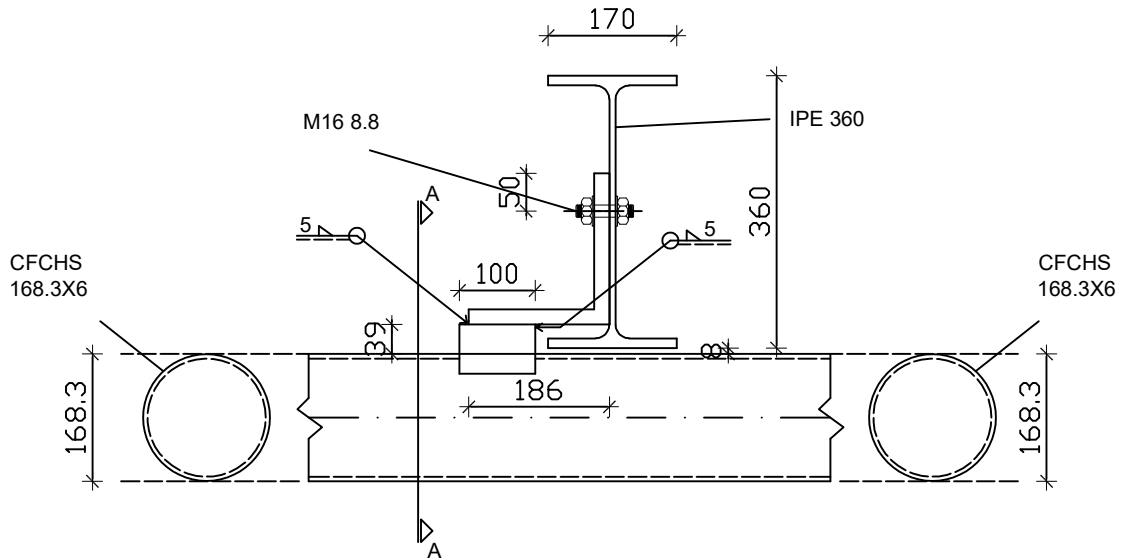

SECTION A-A

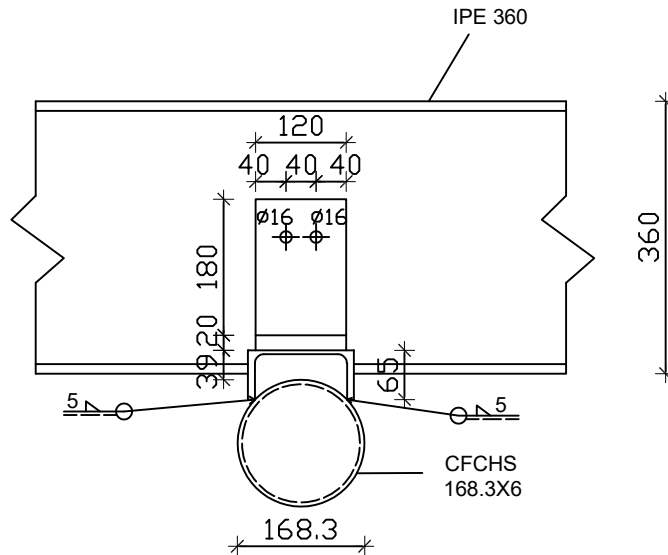

STEEL: S275
BOLTS: M16, 8.8
EXECUTION CLASS 2

 <small>UNIVERSITY OF SPLIT FACULTY OF CIVIL ENGINEERING, ARCHITECTURE AND GEODESY 21000 SPLIT, MATICE HRVATSKE 15 t: +385 (0)21 302030, fax: +385 (0)21 409117</small>	SUPERVISOR: ING. MICHAL JANDERA; Ph.D. ING. VLADIMIR DIVIĆ; Ph.D.	SCALE: 1:10
	THEME OF PROJECT: Sports hall	DATE: september 2020.
	TITLE OF APPENDIX: purlin - upper cord joint	NUMBER OF PROJECT: 340/19-A
		STUDENT: Antonio Perić
		NUMBER: 15