

# Novi duh "stare uljare"

---

Žanetić, Karmen

## Supplement / Prilog

Publication year / Godina izdavanja: **2021**

Permanent link / Trajna poveznica: <https://urn.nsk.hr/urn:nbn:hr:123:356493>

Rights / Prava: [In copyright](#)/[Zaštićeno autorskim pravom.](#)

Download date / Datum preuzimanja: **2024-08-25**



Repository / Repozitorij:

[FCEAG Repository - Repository of the Faculty of Civil Engineering, Architecture and Geodesy, University of Split](#)



UNIVERSITY OF SPLIT

  
DIGITALNI AKADEMSKI ARHIVI I REPOZITORIJI

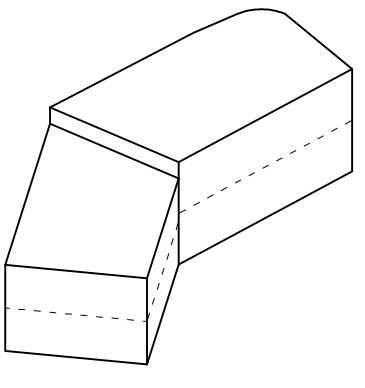

- postojeće stanje

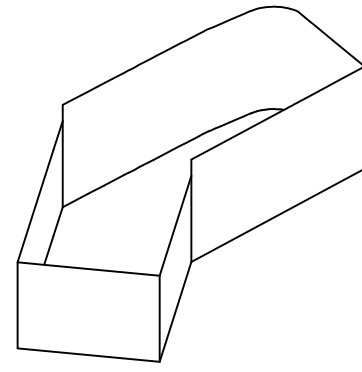

- očuvanje vanjskih gabarite zgrade  
- rušenje interijera

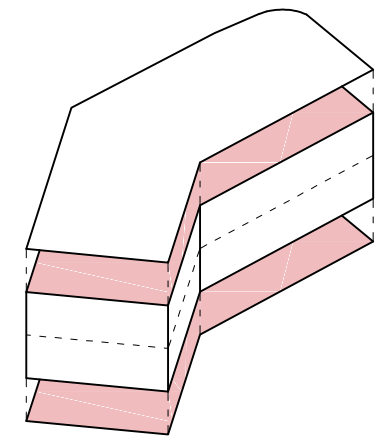

- dodavanje 2. etaže  
- iskopavanje podruma

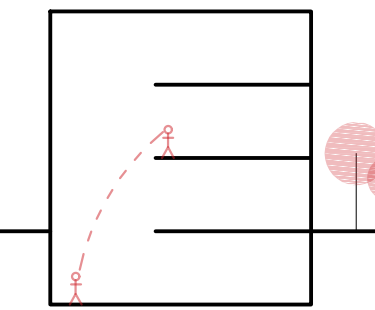

- vizualna povezanost prostora

KONCEPT

KNJIŽNICA  
JAVNO  
KULTURA

ZAŠTIĆENO/UČENJE/  
KONCENTRACIJA  
OTVORENO/DIJELENJE/RELAKSACIJA  
ZATVORENO/DOGAĐAJI/IZVOĐENJE

- stvaranje triju zona u jednoj zgradi

- različiti karakteri prostora

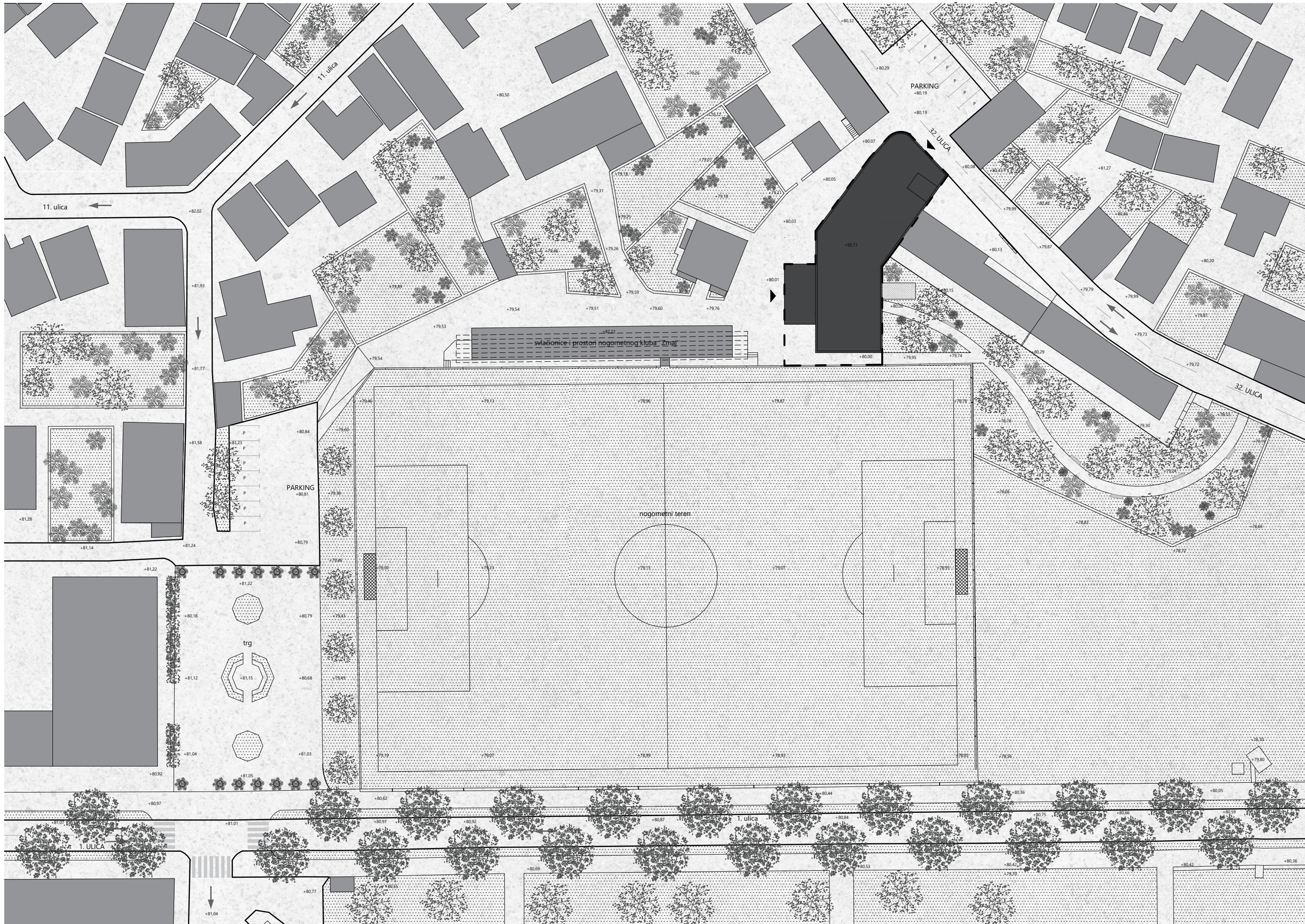

SITUACIJA

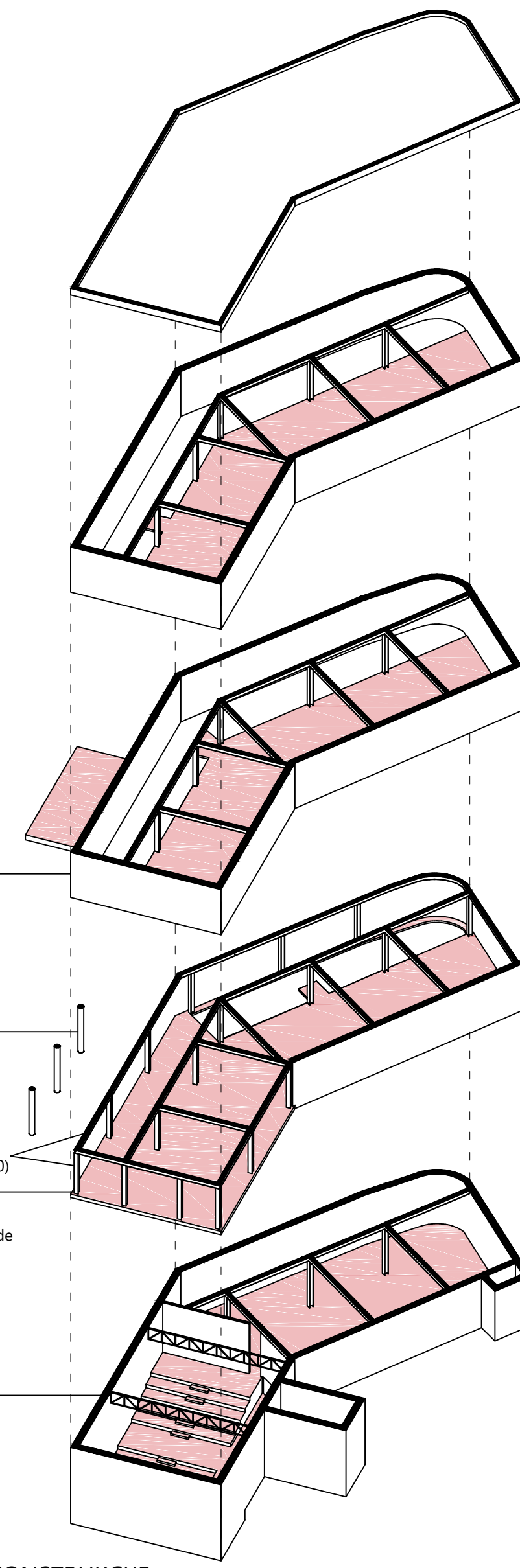

AKSONOMETRIJA KONSTRUKCIJE

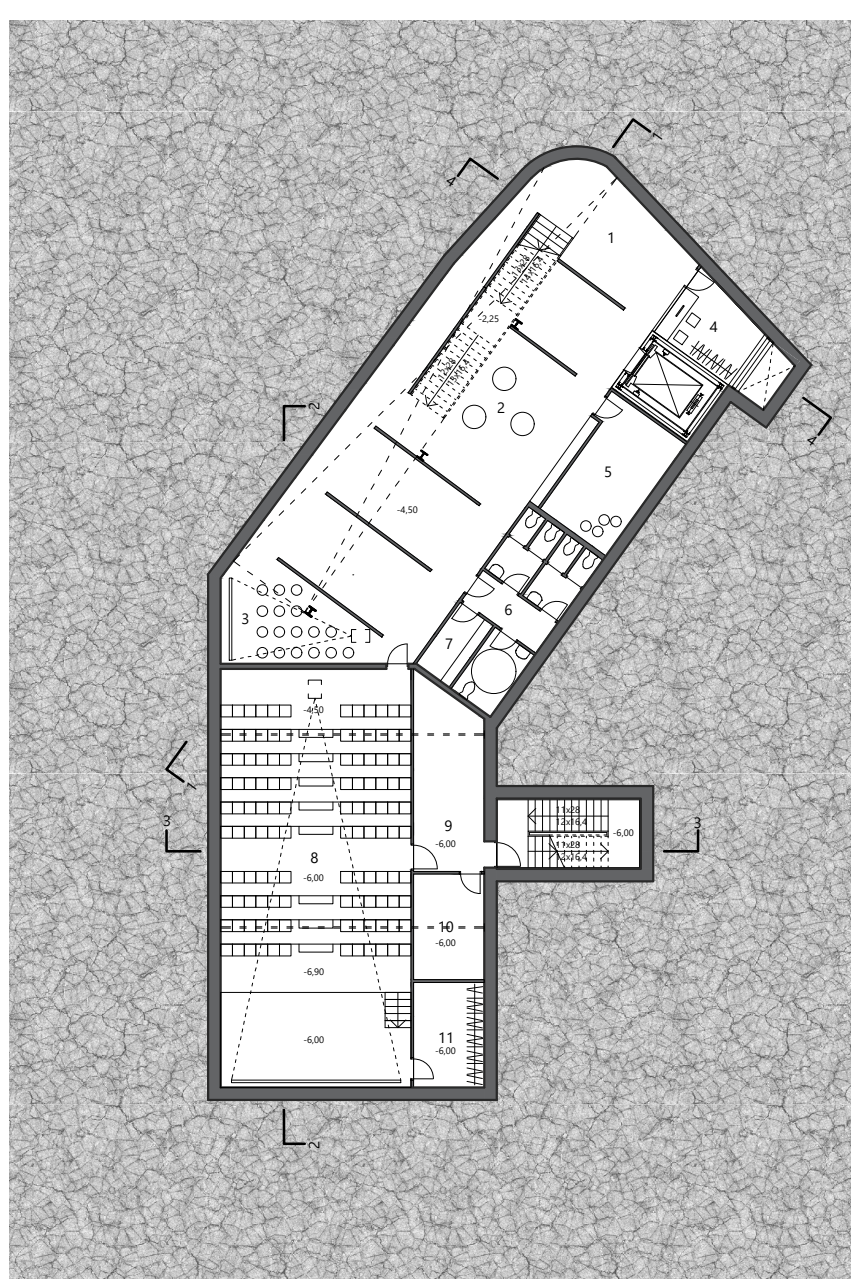

TLOCRT PODRUMA

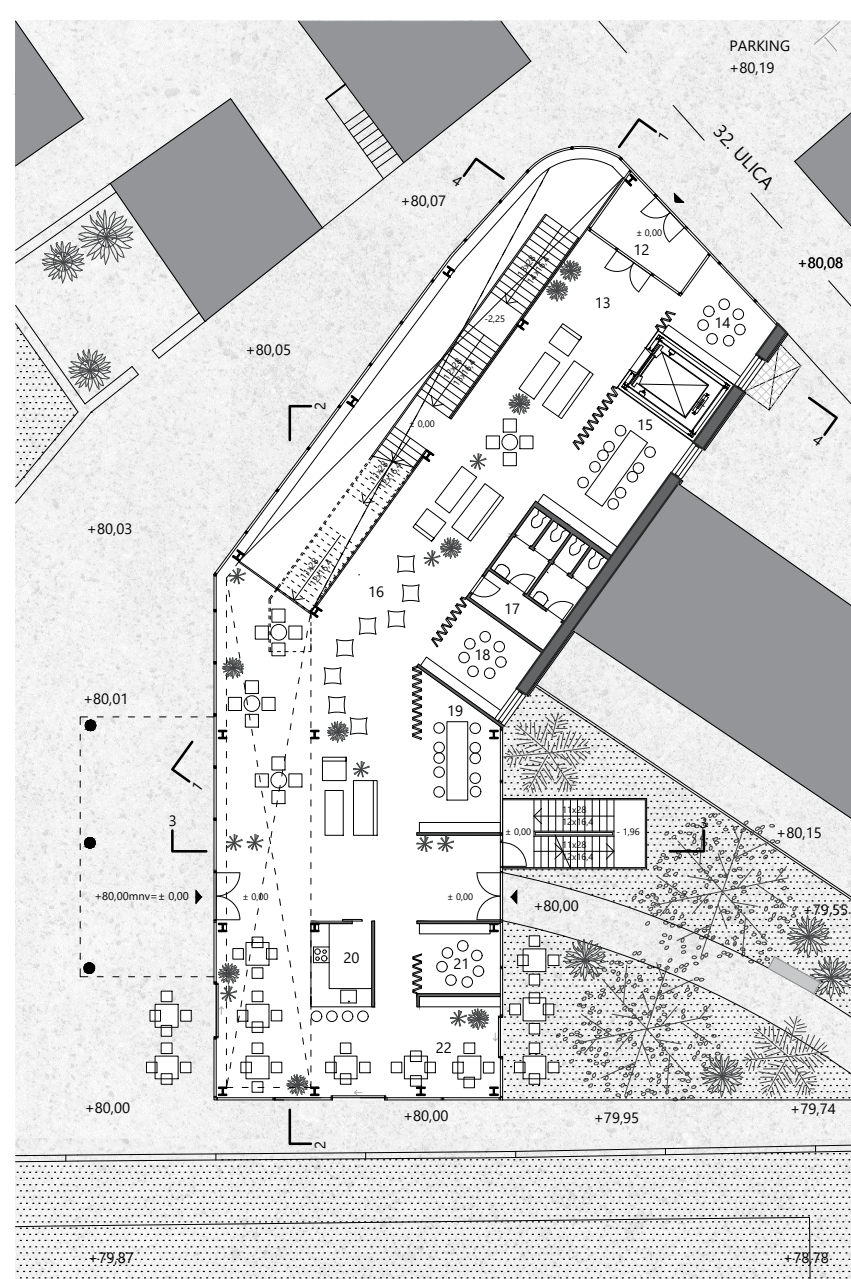

TLOCRT PRIZEMLJA

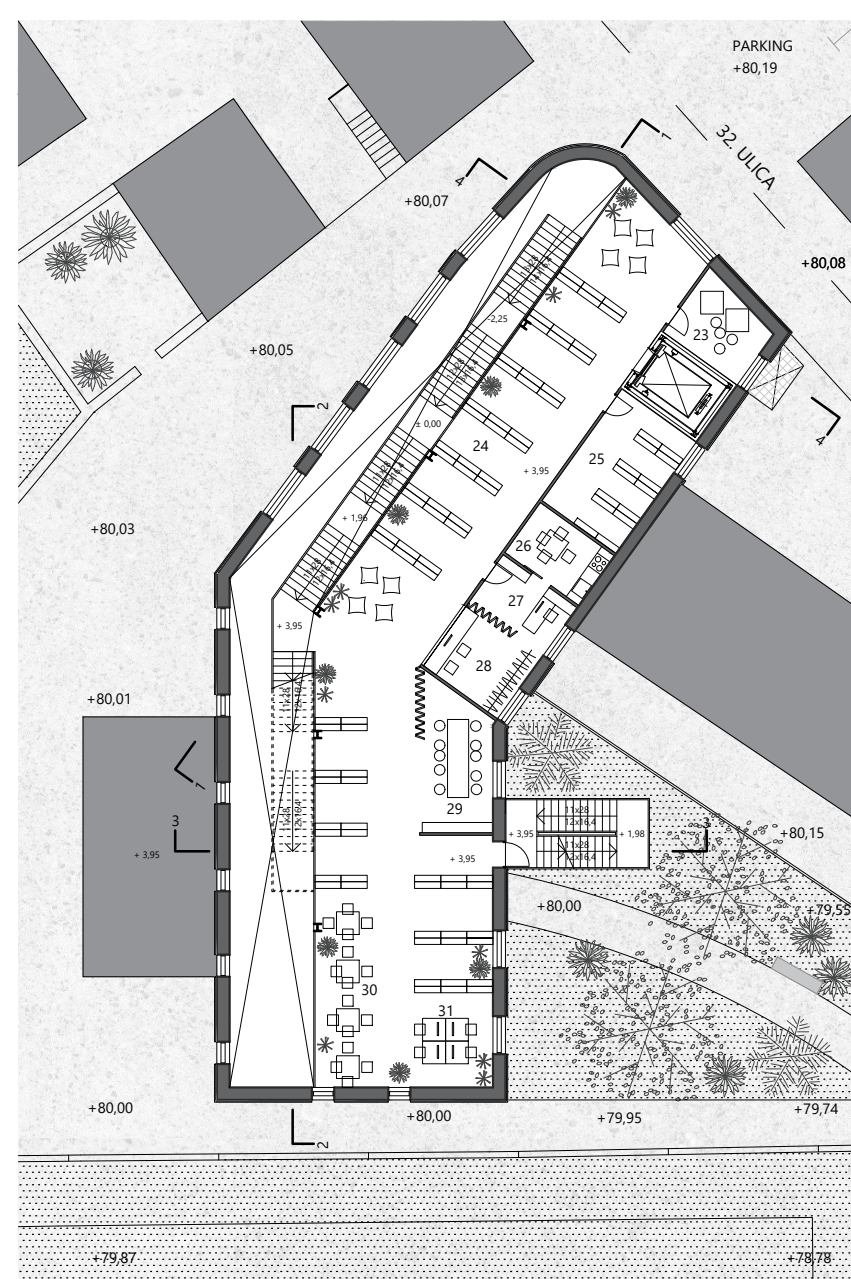

TLOCRT 1. KATA



PRESJEK 3-3



PRESJEK 2-2

IME I PREZIME  
NASLOV DIPLOMSKOG RADA  
AKADEMSKA GODINA  
MENTOR  
KOMENTOR  
KONZULTANT

KARMEN ŽANETIĆ  
NOVI DUH "STARE ULJARE"  
2020 / 2021  
izv. prof. art. NIKOLA POPIĆ  
doc. dr. sc. HRVOJE BARTULOVIĆ  
izv. prof. dr. sc. NIKOLINA ŽIVALJIĆ

Ovaj diplomski rad u fokus stavlja poimanje knjižnice kao "trećeg prostora" i kao "mjesto susreta" građana lokalne zajednice, a njegov cilj je prenamjena prostora "stare uljare" u Blatu na Korčuli u prostor Narodne knjižnice. Upravo Narodna knjižnica u Blatu sa svim svojim popratnim sadržajima postaje jedno takvo ležerno, društveno, ugodno i opuštено mjesto koje kod pojedinca razvija osjećaj pripadnosti zajednici i omogućava otvorenu komunikaciju o aktualnostima i problemima unutar zajednice. Takvo sigurno i inspirativno mjesto u kojemu se njeguje miran suživot, prihvaćanje, uključenost i tolerancija poticalo bi stanje mentalnog, fizičkog i socijalnog blagostanja pojedinca, lokalne zajednice, a time i društva u cjelini.

