

Prostorna čelična rešetka kao rješenje za nosivu konstrukciju vidikovca "Nebeska šetnica - Skywalk Bikovo"

Rubeša, Lucia

Master's thesis / Diplomski rad

2021

Degree Grantor / Ustanova koja je dodijelila akademski / stručni stupanj:

University of Split, Faculty of Civil Engineering, Architecture and Geodesy / Sveučilište u Splitu, Fakultet građevinarstva, arhitekture i geodezije

Permanent link / Trajna poveznica: <https://urn.nsk.hr/urn:nbn:hr:123:752895>

Rights / Prava: [In copyright](#) / [Zaštićeno autorskim pravom.](#)

Download date / Datum preuzimanja: **2025-01-30**



Repository / Repozitorij:

[FCEAG Repository - Repository of the Faculty of Civil Engineering, Architecture and Geodesy, University of Split](#)



SVEUČILIŠTE U SPLITU
FAKULTET GRAĐEVINARSTVA, ARHITEKTURE I GEODEZIJE

DIPLOMSKI RAD

Rubeša Lucia

Split, 2021.

SVEUČILIŠTE U SPLITU
FAKULTET GRAĐEVINARSTVA, ARHITEKTURE I GEODEZIJE

DIPLOMSKI RAD

**Prostorna čelična rešetka kao rješenje za nosivu konstrukciju
vidikovca „Nebeska šetnica – Skywalk Biokovo“**

Rubeša Lucia

Split, 2021.

SVEUČILIŠTE U SPLITU
FAKULTET GRAĐEVINARSTVA, ARHITEKTURE I GEODEZIJE

STUDIJ: **DIPLOMSKI SVEUČILIŠNI STUDIJ GRAĐEVINARSTVA**

KANDIDAT: Lucia Rubeša

MATIČNI BROJ (JMBAG): 0083218642

KATEDRA: **Katedra za metalne i drvene konstrukcije**

PREDMET: Metalne Konstrukcije II

ZADATAK ZA DIPLOMSKI RAD

Tema: Prostorna čelična rešetka kao rješenje za nosivu konstrukciju vidikovca „Nebeska šetnica – Skywalk Biokovo“

Opis zadatka: Potrebno je analizirati geometriju konstrukcije vidikovca „Nebeska šetnica – Skywalk Biokovo“ i kao alternativnu nosivu konstrukciju predložiti rješenje u obliku čelične prostorne rešetke. Za predloženo rješenje potrebno je uzeti u obzir europske norme za projektiranje konstrukcija i prema njima izvršiti: - izračun stalnih i promjenjivih opterećenja uz postojeće lokacijske parametre, - odabir profila čelične rešetke uz provjeru graničnog stanja uporabljivosti i graničnog stanja nosivosti, - definiranje i proračun čeličnih spojeva rešetke, - provjera sekundarnih čeličnih elemenata, - provjera staklene konstrukcije poda vidikovca. Za prostornu čeličnu konstrukciju potrebno je izraditi pripadajuće generalne i radioničke nacрте.

U Splitu, 3. ožujka 2021.g.

Voditelj Diplomskog rada:

doc.dr.sc. Ivana Uzelac Glavinić

Predsjednik Povjerenstva
za završne i diplomske ispite:
Doc. dr. sc. Ivo Andrić

Prostorna čelična rešetka kao rješenje za nosivu konstrukciju vidikovca „Nebeska šetnica – Skywalk Biokovo“

Sažetak:

Tema ovog diplomskog rada je proračun alternativne varijante postojeće konstrukcije – vidikovac „Nebeska šetnica – Skywalk Biokovo“ koja se nalazi na vrhu litice Biokova. Nosivi sustav spomenute konstrukcije „Nebeska šetnica – Skywalk Biokovo“, izveden je od prednapetog betona, dok se u ovom radu analiziraju dvije modificirane verzije čiji su nosivi sustavi izvedeni od tropojasne, odnosno četveropojasne čelične rešetke.

Ključne riječi:

Čelik, vidikovac, „Skywalk“, konstrukcija, nosivi sustav

Spatial grid steel as a solution for the load bearing structure of lookout „Nebeska šetnica – Skywalk Biokovo“

Abstract:

The topic of this diploma thesis is the calculation of an alternative variant of an existing structure - the lookout "Nebeska šetnica – Skywalk Biokovo" which is located at the top of the cliff Biokovo. The load bearing system of the mentioned construction "Nebeska šetnica – Skywalk Biokovo" is made of prestressed concrete, while in this paper we analyze two modified versions whose load bearing systems are made of three band or four band steel grid.

Key words:

Steel, lookout, „Skywalk“, construction, load bearing system

Ovim putem želim se zahvaliti svim profesorima Fakulteta Građevinarstva, arhitekture i geodezije koji su mi omogućili završetak studija te se posebno zahvaljujem svojoj mentorici doc.dr.sc. Ivani Uzelac Glavinić na strpljenju i pomoći pri izradi ovog diplomskog rada. Hvala svim kolegama i prijateljima koji su svojim prisustvom uljepšali moje studentske dane. Najveće hvala mojoj obitelji na bezuvjetnoj podršci tijekom cijelog školovanja.

Sadržaj

1. TEHNIČKI OPIS	1
1.1. Opis konstrukcije	1
1.2. O proračunu konstrukcije.....	1
1.3. Materijali.....	2
1.4. Antikorozivna zaštita	2
1.5. Montaža	2
2. ANALIZA OPTEREĆENJA.....	3
2.1. Stalno opterećenje	3
2.2. Vjetar	3
2.2.1. Vjetar na tropojasnu rešetku	10
2.2.2. Vjetar na četveropojasnu rešetku.....	14
2.3. Snijeg	17
2.4. Temperaturno djelovanje	21
2.5. Prometno opterećenje (pješaci).....	24
3. KOMBINACIJE OPTEREĆENJA ZA ČELIČNU KONSTRUKCIJU	26
3.1. Dijagrami reznih sila za kombinacije djelovanja kod tropojasne rešetke.....	26
3.1.1. Kombinacija djelovanja 1	26
3.1.2. Kombinacija djelovanja 2.....	30
3.1.3. Kombinacija djelovanja 3.....	34
3.1.4. Kombinacija djelovanja 4.....	37
3.1.5. Kombinacija djelovanja 5.....	40
3.1.6. Kombinacija djelovanja 6.....	43
3.2. Dijagrami reznih sila kod četveropojasne rešetke	46
3.2.1. Kombinacija djelovanja 1	46
3.2.2. Kombinacija djelovanja 2.....	50
3.2.3. Kombinacija djelovanja 3.....	53
3.2.4. Kombinacija djelovanja 4.....	56
3.2.5. Kombinacija djelovanja 5.....	59
3.2.6. Kombinacija djelovanja 6.....	62
3.3. Granično stanje uporabljivosti	65
4. DIMENZIONIRANJE ČELIČNE KONSTRUKCIJE.....	67
4.1. Dimenzioniranje tropojasne čelične konstrukcije.....	67
4.1.1. Gornji pojas	67
4.1.2. Donji pojas.....	74
4.1.3. Vertikale	82
4.1.4. Dijagonale.....	90
4.1.5. Horizontale	101
4.2. Dimenzioniranje četveropojasne čelične konstrukcije.....	104
4.2.1. Gornji pojas	104
4.2.2. Donji pojas.....	107
4.2.3. Vertikala	112
4.2.4. Dijagonale – horizontalne gornje	116
4.2.5. Dijagonale – horizontalne donje.....	124
4.2.6. Dijagonala – vertikalna.....	132
4.2.7. Horizontala – gornja	140
4.2.8. Horizontala – donja	144
4.3. Odabir glavne nosive konstrukcije.....	148
5. SPOJEVI GLAVNE ČELIČNE KONSTRUKCIJE	149
5.1. Spoj donji pojas - vertikala	149

5.2.	Spoj Gornji pojas – horizontale – dijagonale - vertikale	156
5.3.	Spoj Temelj – donji pojas	162
5.4.	Spoj Temelj – gornji pojas	170
5.5.	Montažni priključak na gornjem i donjem pojasu	177
5.6.	Montažni priključak na vertikalama i dijagonalama.....	182
6.	PRORAČUN PODNE STAKLENE KONSTRUKCIJE	185
6.1.	Popis normi za proračun staklenih elemenata.....	185
6.2.	Proračun staklenog elementa	187
6.2.1.	Proračun prema Europskim normama	188
6.2.2.	Proračun prema graničnim stanjima.....	189
7.	NACRTI.....	

1. TEHNIČKI OPIS

1.1. Opis konstrukcije

Predmet ovog rada je proračun čelične konstrukcije vidikovca. Konstrukcija vidikovac „Nebeska šetnica – Skywalk Biokovo“ nalazi se na vrhu litice Biokova, na području info centra „Ravna Vlačka” u Parku prirode Biokovo, smješten na k.č. 6945/25, k.o. Tučepi. Dio građevine, šetnica „Nebeska šetnica – Skywalk Biokovo“ izlazi izvan litice i oblika je potkove. Glavna konstrukcija sastoji se od tropojasne čelične rešetke čiji je radijus unutarnje strane gornjeg pojasa 8,5 metara, dok je radijus vanjske strane 10,5 metara. Projicirana udaljenost gornjeg i donjeg pojasa tropojasne rešetke iznosi 2 metra.

Gornji i donji pojas jednakih su dimenzija – u prvim poljima konstrukcije izvedeni su od profila CFRHS 180x120x8 (mm), dok su na ostalim poljima nešto manje dimenzije - CFRHS 180x100x5 (mm). Horizontale koje povezuju unutarnju i vanjsku stranu gornjeg pojasa izvedene su od profila CFRHS 70x70x4 i jednakih su dimenzija duž građevine. Vertikale i dijagonale predmetne građevine također su pojačane u prvim poljima i izvedene su od profila CFRHS 100x100x5 (mm), dok su na ostalim poljima predviđeni profili CFRHS 90x90x5 (mm). Pod i ograda šetnice su izvedene od stakla.. Za pod 5x16mm, a ogradu 3x16mm, termički obrađenog stakla.

1.2. O proračunu konstrukcije

Proračun unutarnjih sila, momenata savijanja i dimenzioniranje elemenata čelične konstrukcije provedeno je u skladu s Eurocode-om. Proračunom konstrukcije obuhvaćena su sva djelovanja na konstrukciju. S obzirom na lokaciju objekta, posebna pažnja posvećena je opterećenju snijega na konstrukciju. Za potrebe dimenzioniranja elemenata konstrukcije određena je mjerodavna kritična kombinacija opterećenja za provjeru graničnih stanja. Rezultati prikazani u grafičkome dijelu projekta uključuju rezne sile. Analiza konstrukcije provedena je računalnim software-om SCIA Engineer 20.0 dok su spojevi izračunati pomoću software-a IDEA StatiCa 21.0. Sve mjerodavne kombinacije su uzete u obzir, te je svaki element konstrukcije dimenzioniran u skladu njihovim reznim silama.

1.3. Materijali

Materijal za izradu nosive konstrukcije S275. Svi elementi konstrukcije izrađeni su od iste kvalitete čelika, a međusobno su povezani zavarivanjem. Vijci korišteni za izvedbu ovog krovišta industrijske hale su M16 kvalitete 8.8. Spojevi elemenata konstrukcije uključuju dodatne pločice i ukrute, također iste kvalitete čelika. Pod je izveden od termički obrađenog stakla 5x16mm dok je ograda izvedena od stakla 3x16 mm.

1.4. Antikorozivna zaštita

Svi dijelovi čelične konstrukcije moraju biti zaštićeni od korozije prema odredbama "Pravilnika o tehničkim mjerama i uvjetima za zaštitu čeličnih konstrukcije od korozije". Kao vrsta zaštite od korozije odabrana je zaštita pocinčavanjem. Ukupna debljina zaštitnog sloja usvaja se 200 µm. Svi dijelovi konstrukcije se također premazuju i završnim slojem premaza. Nakon završene izvedbe svakog sloja potrebno je provjeriti debljinu i prionjivost namaza.

1.5. Montaža

Montaža se mora provesti prema planu montaže. Međustanja konstrukcije u fazi montaže potrebno je provjeriti vodeći računa o mjestima hvatanja u fazama podizanja i montaže. Elementi konstrukcije se izrađuju u tvornicama te transportiraju na gradilište i zatim montiraju (montažni način izgradnje). Potrebno je obratiti posebnu pažnju na montažu i transport da bi se izbjegla nepotrebna oštećena.

2. ANALIZA OPTEREĆENJA

2.1. Stalno opterećenje

- vlastita težina automatski je uključena u računalni program

2.2. Vjetar

- pritisak vjetra na vanjske površine: $w_e = q_p \cdot c_e(z_e) \cdot c_{pe}$ [kN/m²]

gdje je:

q_{ref} – poredbeni tlak vjetra pri srednjoj brzini vjetra

$C_e(z_e)$ – koeficijenti izloženosti koji uzimaju u obzir neravnine terena

$z_e; z_i$ – poredbene visine za lokalni ili unutarnji tlak

$c_{pe}; c_{pi}$ – vanjski i unutarnji koeficijent pritiska

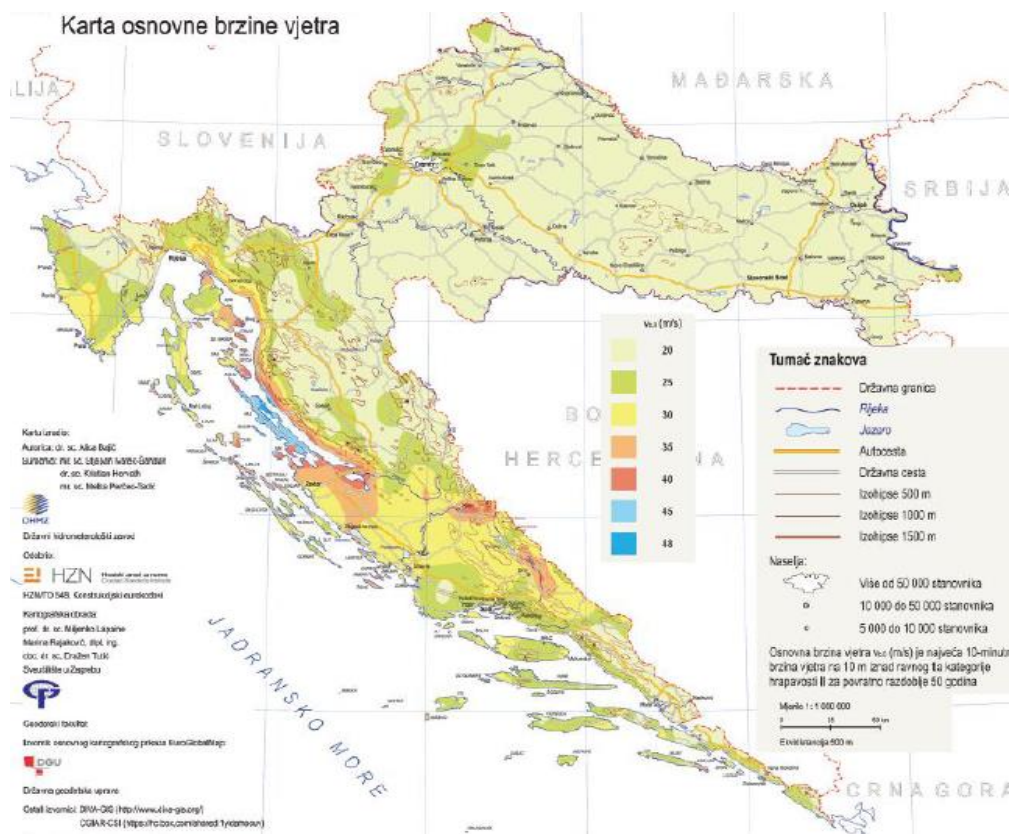

Slika 1.2.1. Zemljovid područja opterećenja vjetrom

$$q_b = \frac{1}{2} \cdot \rho \cdot v_b^2 \text{ [kN/m}^2\text{]}$$

gdje je:

v_b – osnovna brzina vjetra

ρ – gustoća zraka ($\rho=1,25 \text{ kg/m}^3$)

Osnovna brzina vjetra v_b , dana je izrazom:

$$v_b = C_{dir} \cdot C_{season} \cdot v_{b0}$$

gdje je:

v_b – osnovna brzina vjetra

C_{dir} – koeficijent smjera vjetra (obično uzima vrijednost 1,0)

C_{season} – koeficijent ovisan o godišnjem dobu (obično uzima vrijednost 1,0)

Osnovni pritisak vjetra:

$v_b = 30$ (m/s) → očitano za predio Ravna Vlačka

$$C_{dir} = C_{season} = 1,0$$

$$v_b = v_{b,0} \cdot C_{dir} \cdot C_{season} =$$

$$= 30 \cdot 1,0 \cdot 1,0 = 30 \text{ (m/s)}$$

$$\rho = 1,25 \frac{\text{kg}}{\text{m}^3}$$

$$q_b = \frac{1}{2} * 1,25 * 30^2 = 562,5 \left(\frac{\text{N}}{\text{m}^2} \right) \approx 0,56 \left(\frac{\text{kN}}{\text{m}^2} \right)$$

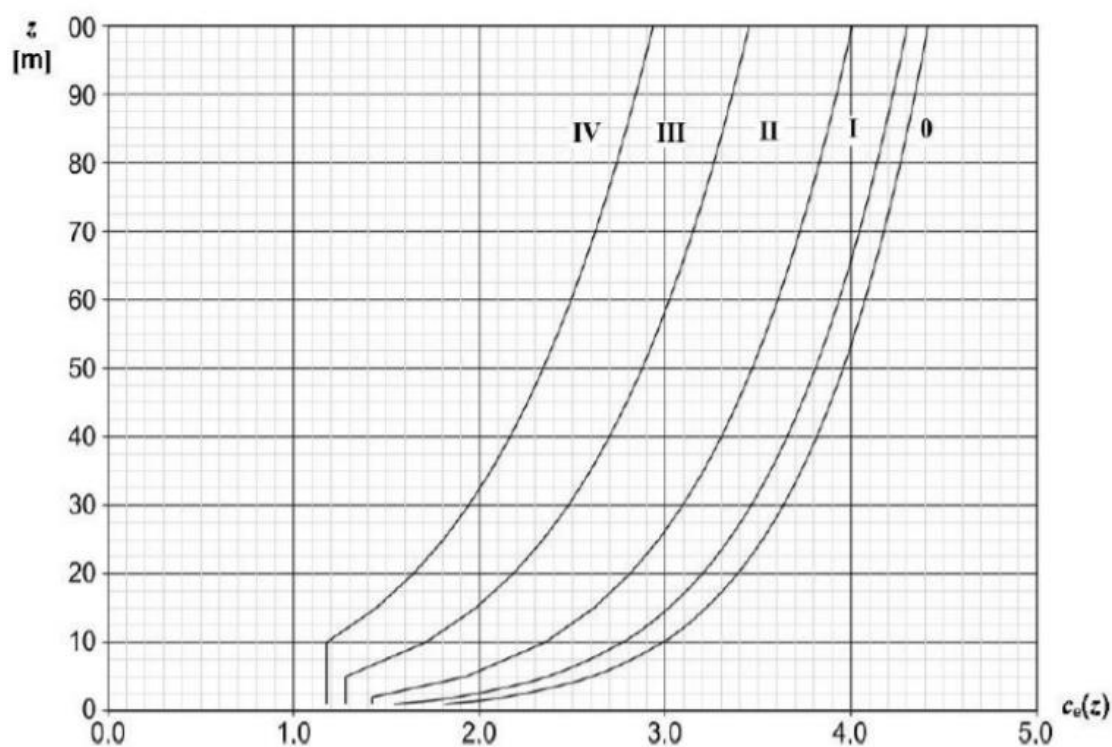

Prikazi koeficijenta izloženosti $c_e(z)$ za $c_0(z) = 1,0$, $k_1 = 1,0$

Slika 1.2.2. Prikazi koeficijena izloženosti

$C_{e(z)} = 3$ - očitani faktor izloženosti za kategoriju II.

$$q_p(z) = q_b \cdot C_{e(z)}$$

$$q_p(z) = 0,56 \cdot 3 = 1,68 \frac{kN}{m^2}$$

a) Ograda

$$A_{ref} = 21,0 \cdot 1,20 = 25,2 \text{ m}^2$$

$$c_f = c_{f,0} \cdot \Psi_\lambda$$

$c_{f,0}$ - koeficijent sile bez učinka kraja

$$\lambda = L/b = 21/1,2 = 17,5$$

φ - omjer punoće

A – zbroj projiciranih površina pojedinih elemenata

A_c – ukupna površina

$$\varphi = 1,0$$

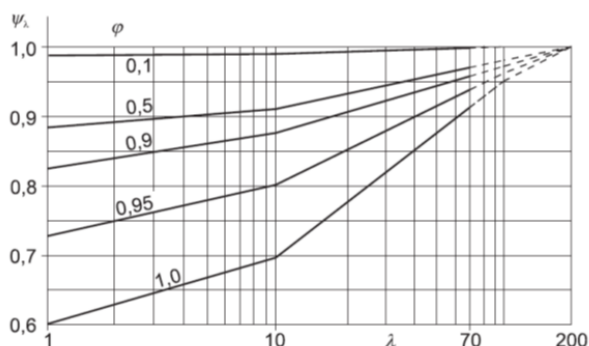

Slika 1.2.3. Orijentacijske vrijednosti faktora učinka kraja Ψ_λ kao funkcije omjera punoće φ i vitkosti λ

$$\Psi_\lambda = 0,77$$

U nacionalnom dodatku smije se odrediti $c_{f,0}$. Za sve elemente bez toka preko slobodnog kraja preporučena vrijednost je 2,0. Ta vrijednost temelji se na mjerenjima u uvjetima slabe turbulencije. Pretpostavlja se da je to sigurna vrijednost. (1)

$$\text{Slijedi: } c_f = 2,0 \cdot 0,77 = 1,54$$

$$F_w = 1,68 \cdot 1,54 \cdot 25,2 = 65,20 \text{ kN}$$

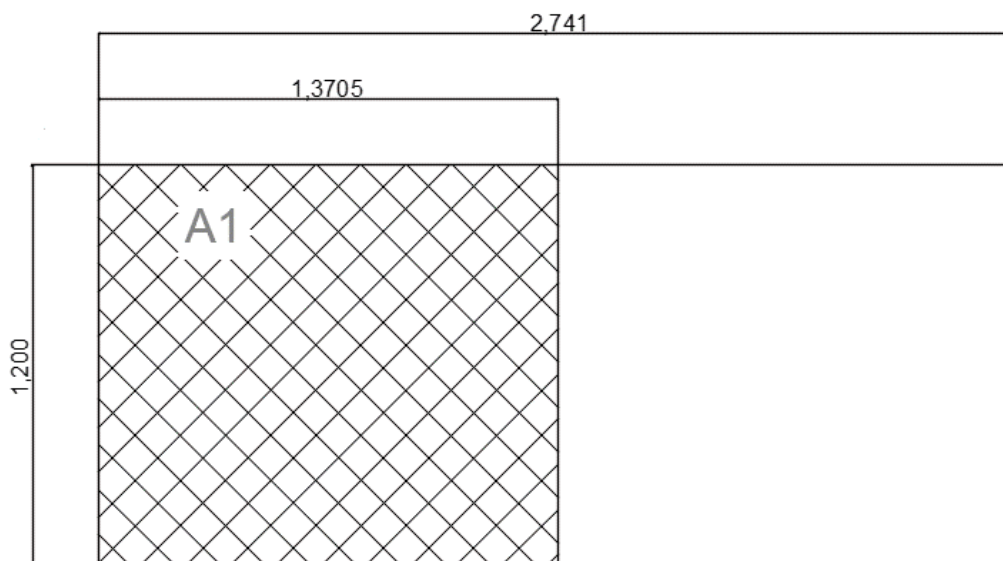
Raspored opterećenja u čvorove

Slika 1.2.4. Prikaz površine ograde

$$A1 = 1,6446 \text{ m}^2$$

Za vertikalni rubni dio ograde:

n – broj stakala

l – vertikalni rub ograde $\rightarrow l = 1,2 \text{ m}$

$$\frac{F_w}{n} = \frac{65,20}{12} = 5,43 \text{ kN}$$

$$W2 = \frac{F_w}{l} = \frac{5,43}{1,2} = 4,53 \text{ kN/m'}$$

b) Rub ograde

$$A_{\text{ref}} = 21,0 \cdot 0,08 = 1,68 \text{ m}^2$$

Koeficijent vanjskog tlaka ovisi o Reynoldsovu broju

$$\text{Re} = \frac{b \cdot v_m(z_e)}{\nu}$$

b – promjer stupa ($8 \text{ cm} = 0,08 \text{ m}$)

ν - kinematička viskoznost zraka ($\nu = 15 \cdot 10^{-6} \text{ [m}^2/\text{s]}$)

$v_m(z_e)$ - srednja vrijednost brzine vjetra (poredbena brzina vjetra)

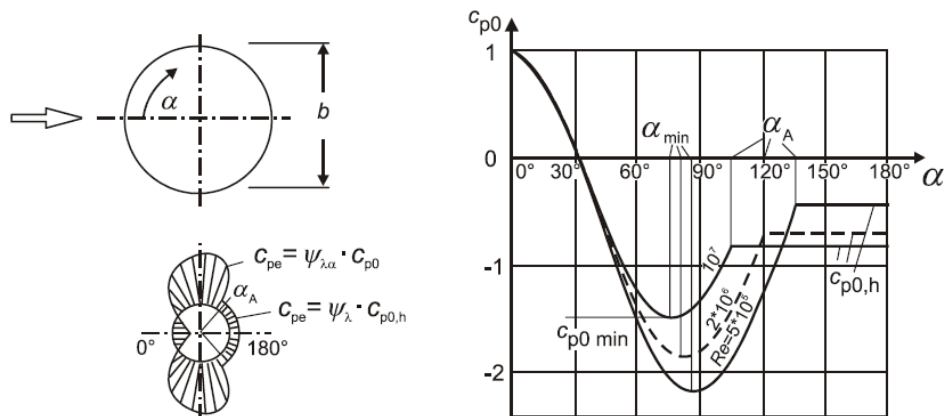

Slika 1.2.5.. Raspodjela tlaka na valjku pri različitim Reynoldsovima brojevima

Re	α_{min}	$c_{p0,min}$	α_A	$c_{p0,h}$
$5 \cdot 10^5$	85	-2,2	135	-0,4
$2 \cdot 10^6$	80	-1,9	120	-0,7
10^7	75	-1,5	105	-0,8

Tablica 1.2.1. Tipične vrijednosti krivulja sa slike iznad

α_{min} - mjesto najmanjeg tlaka

$c_{p0,min}$ - vrijednost najmanjeg koeficijenta tlaka

α_A - mjesto odvajanja strujanja

$c_{p0,h}$ - koef. tlaka zavjetrenog djela valjka

ρ – gustoća zraka ($1,25 \text{ kg/m}^3$)

$$v_m(z_e) = \sqrt{\frac{2 \cdot q_p}{\rho}} = \sqrt{\frac{2 \cdot 1,68}{1,25}} = 51,85 \text{ m/s}$$

$$Re = \frac{0,08 \cdot 51,85}{15 \cdot 10^{-6}} = 276533,3 = 2,7653 \cdot 10^5$$

Koeficijent vanjskog tlaka valjka

$$c_{pe} = c_{p,0} \cdot \psi_{\lambda a}$$

$c_{p,0}$ - koeficijent vanjskog tlaka elementa beskonačne vitkosti

$\psi_{\lambda a}$ - koeficijent umanjenja s obzirom na vitkost

Koeficijent umanjenja zbog vitkosti

$$\psi_{\lambda a} = 1 \text{ za } 0^\circ \leq \alpha \leq \alpha_A$$

$$360^\circ - \alpha_A \leq \alpha \leq 360$$

$$\psi_{\lambda a} = \psi_\lambda \quad \alpha_A \leq \alpha \leq 360 - \alpha_A$$

$$c_{pe} = c_{p,0} \text{ i } \psi_{\lambda a} = 1 \text{ za } 0^\circ \leq \alpha \leq \alpha_A$$

$$360^\circ - \alpha_A \leq \alpha \leq 360$$

$$c_{pe} = c_{p0,h} \cdot \psi_\lambda \text{ i } \psi_{\lambda a} = \psi_\lambda \quad \alpha_A \leq \alpha \leq 360 - \alpha_A$$

$$\lambda = L/b = 21/0,08 = 262,5$$

$$\varphi = 1,0$$

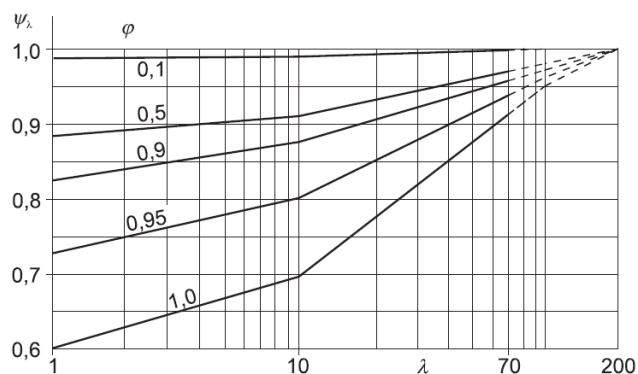

Slika 1.2.6. Koeficijent umanjenja na osnovi vitkosti ψ_λ u ovisnosti o proračunskoj vitkosti λ i za različite stupnjeve punoće φ

$$\psi=1,0$$

Vrsta površine	Istovrijedna hrapavost [mm]	Vrsta površine	Istovrijedna hrapavost [mm]
staklo	0,0015	glatki beton	0,2
uglačani metal	0,002	blanjano drvo	0,5
fina boja	0,006	grubi beton	1,0
prskana boja	0,02	grubo rezano drvo	2,0
sjajni čelik	0,05	hrđa	2,0
lijevano željezo	0,2	ziđe	3,0
galvanizirani čelik	0,2		

Tablica 1.2.2. Istovrijedna hrapavost površine k

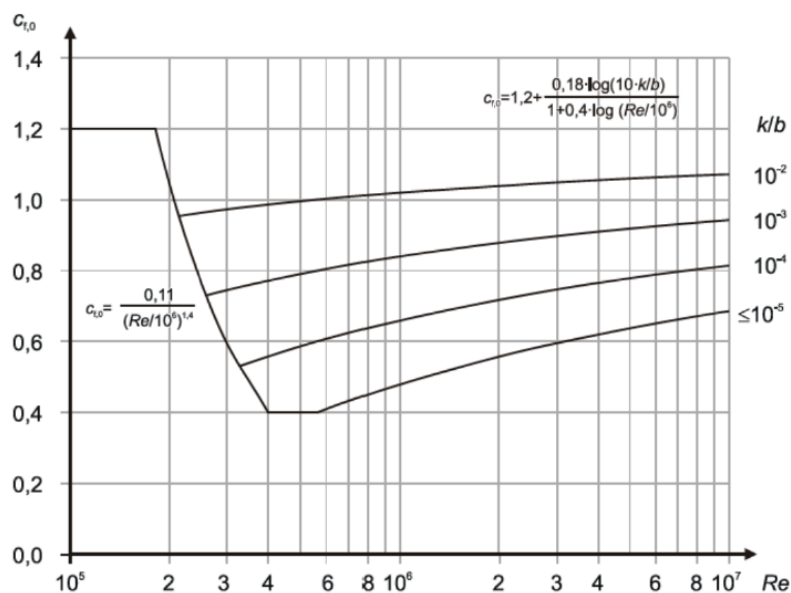

Slika 1.2.7. Koeficijent sile c_{f0} za kružne valjke bez toka preko slobodnog kraja i za različite istovrijedne hrapavosti k/b

$$k/b = 0,05/80 = 6 \cdot 10^{-5}$$

$$\text{Očitano: } c_{f0} = 0,6$$

$$c_f = 0,6 \cdot 1,0 = 0,6$$

$$F_w = 1,68 \cdot 0,6 \cdot 1,68 = 1,69 \text{ kN}$$

Raspored opterećenja

l – dužina polukružnog luka

$$l = \frac{2r\pi}{2} = 10,5\pi = 32,99 \text{ m}$$

$$W3 = \frac{F_w}{l} = \frac{1,69}{32,99} = 0,05 \text{ kN/m'}$$

2.2.1. Vjetar na tropojasnu rešetku

$$F_w = q_p \cdot c_f \cdot A_{ref}$$

F_w – ukupna sila na konstrukciju q_{ref} – poredbeni tlak vjetra

c_f – koeficijent sile (služi za izračun ukupne sile)

A_{ref} – referentna površina konstrukcije

c) Rešetka

$$A_{ref} = 289120 \text{ cm}^2$$

$$c_f = c_{f,0} \cdot \Psi_\lambda$$

$$\lambda = L/b = 21/2 = 11,5$$

Br.	Položaj konstrukcije, vjetar okomito na ravninu stranice	Proračunska vitkost λ
1		<p>Za poligonalne, pravokutne i profile oštrog rubova te za rešetkaste konstrukcije: za $l \geq 50$ m, $\lambda = 1,4$, l/b ili $\lambda = 70$, odabire se manja vrijednost za $l < 15$ m, $\lambda = 2$, l/b ili $\lambda = 70$, odabire se manja vrijednost. Za kružne valjke: za $l \geq 50$ m, $\lambda = 0,7$, l/b ili $\lambda = 70$, odabire se manja vrijednost za $l < 15$ m, $\lambda = l/b$ ili $\lambda = 70$, odabire se manja vrijednost. Za međuvrijednosti l smije se upotrebljavati linearna interpolacija.</p>
2		
3		
4		

Slika 1.2.1.1. Preporučene vrijednosti za vitkost λ

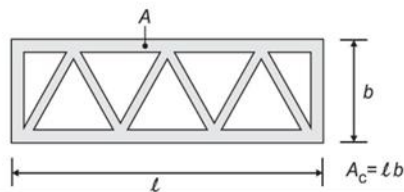

Slika 1.2.1.2. Podaci za omjer punoće φ

$$\varphi = A/A_c$$

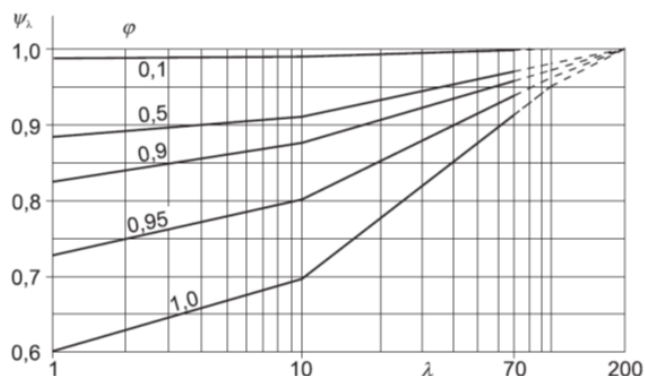

Slika 1.2.1.3. Orijentacijske vrijednosti faktora učinka kraja Ψ_λ kao funkcije omjera punoće φ i vitkosti λ

$$\varphi = 0,5$$

$$\lambda = 11,5 \rightarrow \Psi_\lambda = 0,92$$

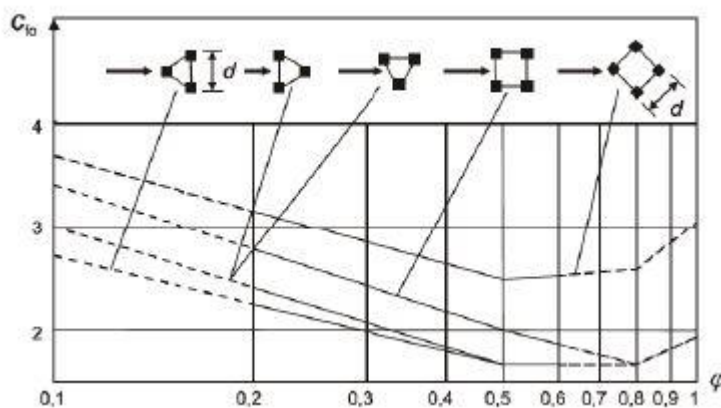

Slika 1.2.1.4. Koeficijent sile c_{f0} za prostornu rešetkastu konstrukciju s elementima kutnika

Koeficijent sile c_f za rešetkaste konstrukcije i skele s paralelnim pojasevima:

Očitano: $c_{f0} = 1,0$ (trostrana opcija)

$$c_f = 0,92 \cdot 1,0$$

$$c_f = 0,92$$

Raspored opterećenja

$$F_w = q_p \cdot c_f \cdot A_{\text{ref}}$$

$$F_w = 1,68 \cdot 0,92 \cdot (209712 \cdot 100^{-2}) = 32,41 \text{ kN}$$

Vanjski dio- vanjski dio preuzima 60% ukupne sile

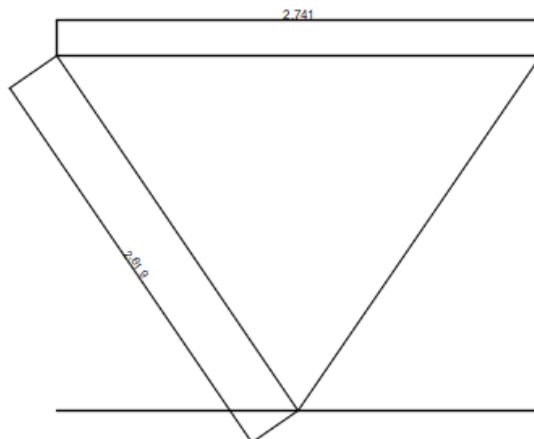

Slika 1.2.1.5. Prikaz segmenta vanjskog dijela trobojne čelične rešetke

$$F_{w\text{-vanjski}} = 0,60 \cdot 32,41 = 19,45 \text{ kN}$$

Gornji pojas:

$$F_w = 19,45/2 = 9,73 \text{ kN}$$

$$\frac{F_w}{n} = \frac{9,73}{12} = 0,81 \text{ kN}$$

$$W1 = \frac{0,81}{l} = \frac{0,81}{2,741} = 0,30 \text{ kN/m}$$

Unutarnji dio

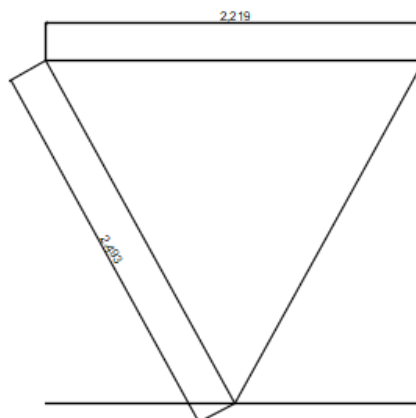

Slika 1.2.1.6. Prikaz segmenta unutarnjeg dijela trobojne čelične rešetke

$$\underline{F_{w-unutarnji}} = 0,40 \cdot 32,41 = 12,96 \text{ kN}$$

Gornji pojas:

$$F_w = 12,96/2 = 6,48 \text{ kN}$$

$$\frac{F_w}{n} = \frac{6,48}{12} = 0,54 \text{ kN}$$

$$W1 = \frac{0,54}{l} = \frac{0,54}{2,219} = 0,24 \text{ kN/m}$$

Donji pojas

$$\underline{F_w} = 32,41$$

$$\frac{F_w}{n} = \frac{32,41}{12} = 2,70 \text{ kN}$$

$$W1 = \frac{2,70}{l} = \frac{2,70}{2,459} = 1,10 \text{ kN/m}$$

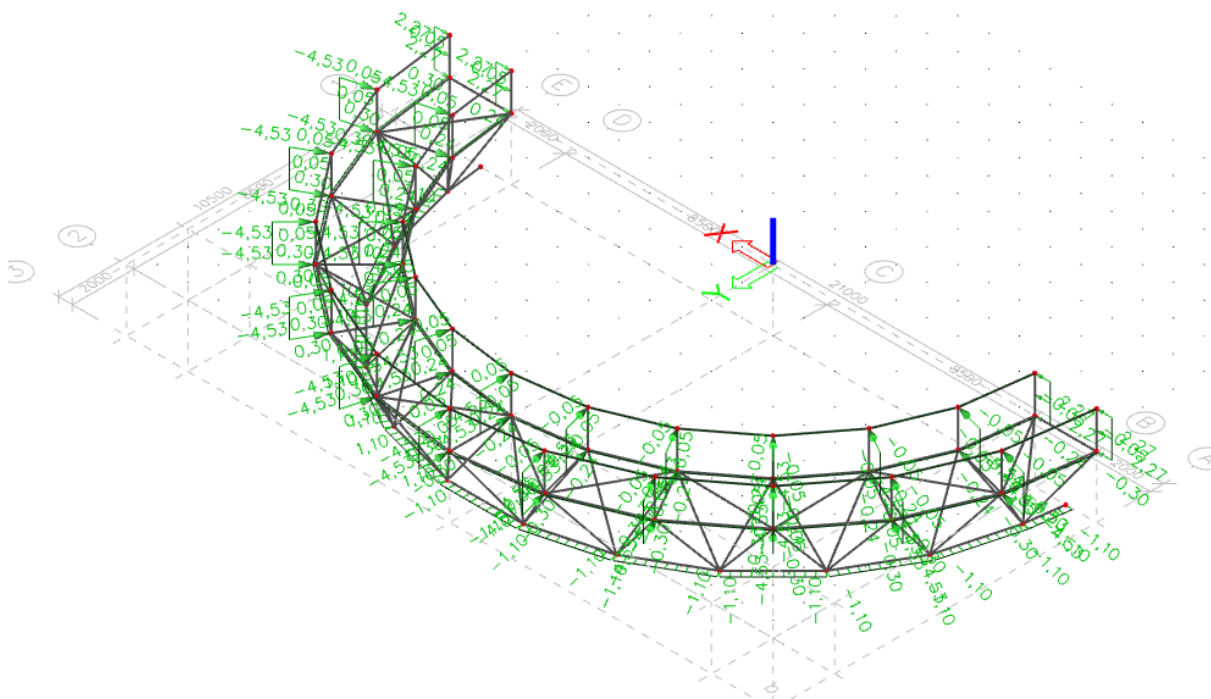

Slika 1.2.1.7. Prikaz opterećenja vjetrom na tropojasnu čeličnu konstrukciju

2.2.2. Vjetar na četveropojasnu rešetku

d) Rešetka

$$\varphi = A/A_c$$

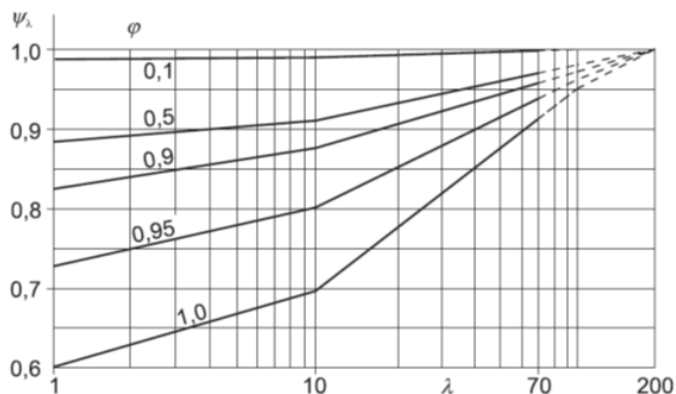

Slika 1.2.2.1. Orijentacijske vrijednosti faktora učinka kraja Ψ_λ kao funkcije omjera punoće φ i vitkosti λ

$$\varphi = 0,5$$

$$\lambda = 11,5 \rightarrow \Psi_\lambda = 0,92$$

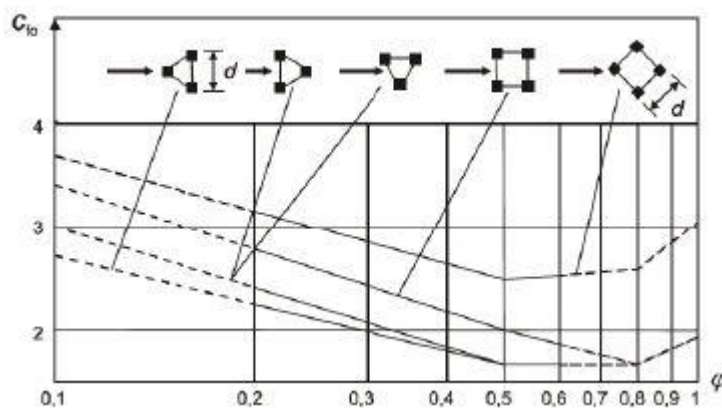

Slika 1.2.2.2. Koeficijent sile c_{f0} za prostornu rešetkastu konstrukciju s elementima kutnika

Koeficijent sile c_f za rešetkaste konstrukcije i skele s paralelnim pojasevima:

$$c_f = c_{f,0} \cdot \Psi_\lambda$$

Očitano: $c_{f0} = 2,0$

$$c_f = 0,92 \cdot 2,0$$

$$c_f = 1,84$$

Raspored opterećenja

$$F_w = q_p \cdot c_f \cdot A_{ref}$$

$$F_w = 1,68 \cdot 1,84 \cdot (289120 \cdot 100^{-2}) = 89,37 \text{ kN}$$

Vanjski dio – vanjski dio preuzima 60% ukupne sile

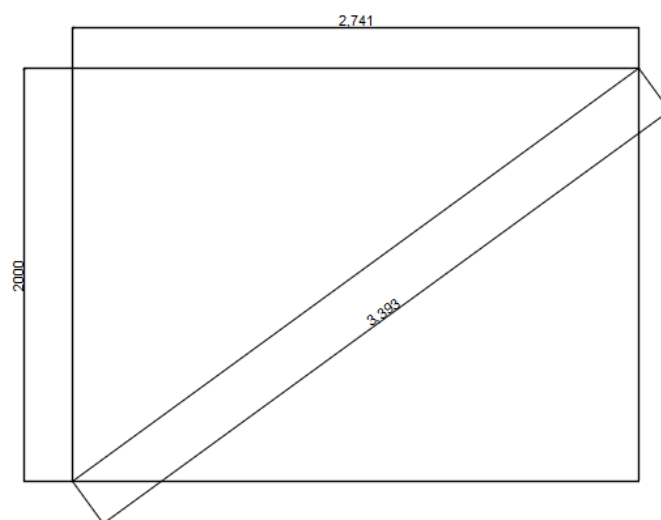

Slika 1.2.2.3. Prikaz segmenta vanjskog dijela četveropojasne čelične rešetke

$$F_{w\text{-vanjski}} = 0,60 \cdot 89,37 = 53,62 \text{ kN}$$

Gornji i donji pojas:

$$F_w = 53,62 / 2 = 26,81 \text{ kN}$$

$$\frac{F_w}{n} = \frac{26,81}{12} = 2,23 \text{ kN}$$

$$W1 = \frac{2,23}{l} = \frac{2,23}{2,741} = 0,81 \text{ kN/m}$$

Unutarnji dio

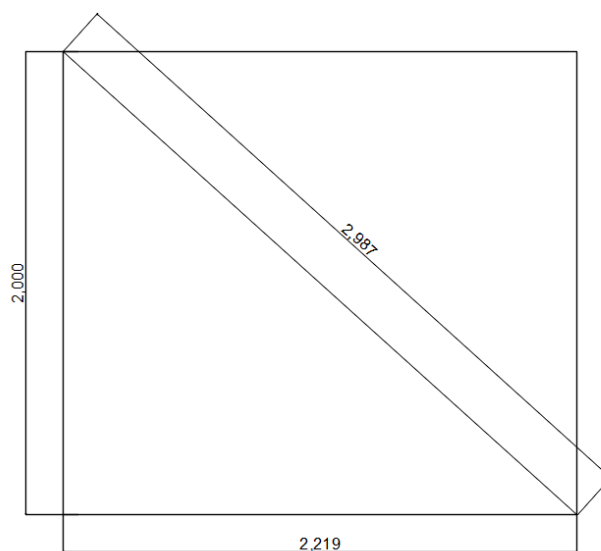

Slika 1.2.2.4. Prikaz segmenta unutarnjeg dijela četveropojasne čelične rešetke

$$F_{w-\text{unutarnji}} = 0,40 \cdot 89,37 = 35,75 \text{ kN}$$

Gornji i donji pojas:

$$F_w = 35,75/2 = 17,88 \text{ kN}$$

$$\frac{F_w}{n} = \frac{17,88}{12} = 1,49 \text{ kN}$$

$$W1 = \frac{1,49}{l} = \frac{1,49}{2,219} = 0,67 \text{ kN/m}$$

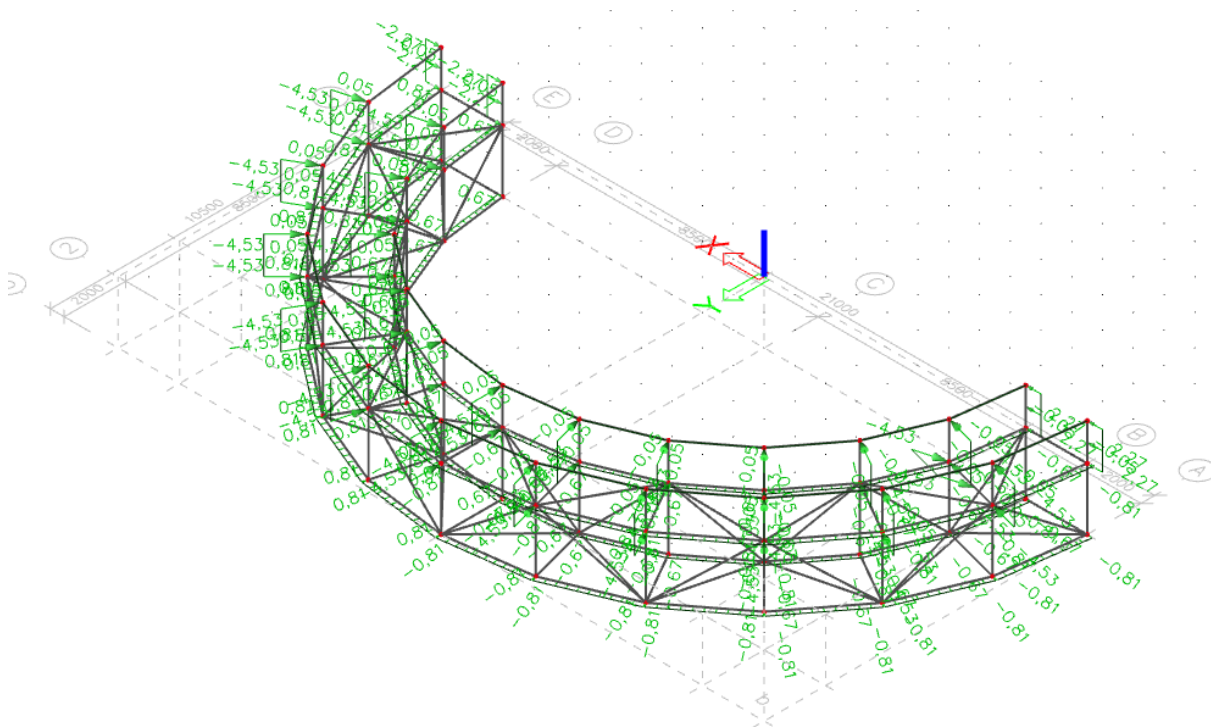

Slika 1.2.2.5. Prikaz opterećenja vjetrom na četveropojasnu čeličnu konstrukciju

2.3. Snijeg

Proračun je izvršen za Platformu Vidikovac („Nebeska šetnica – Skywalk Biokovo“) na predjelu Ravne Vlačke, P.P. Biokovo. Za lokaciju građevine u zoni II – Zaleđe Dalmacije, Primorja i Istre iz karte snježnih područja za nadmorsku visinu 1200 – 1300 m (1228 m), očitana je karakteristična vrijednost opterećenja snijega na tlu:

$$\Rightarrow s_k = 7 \text{ kN/m}^2$$



Slika 1.3.1. Karta područja za opterećenja snijegom

Nadmorska visina do [m]	1. područje – priobalje i otoci [kN/m ²]	2. područje – zaleđe Dalmacije, Primorja i Istre [kN/m ²]	3. područje – kontinentalna Hrvatska [kN/m ²]	4. područje – gorska Hrvatska [kN/m ²]
100	0,50	0,75	1,00	1,25
200	0,50	0,75	1,25	1,50
300	0,50	0,75	1,50	1,75
400	0,50	1,00	1,75	2,00
500	0,50	1,25	2,00	2,50
600	0,50	1,50	2,25	3,00
700	0,50	2,00	2,50	3,50
800	0,50	2,50	2,75	4,00
900	1,00	3,00	3,00	4,50
1 000	2,00	4,00	3,50	5,00
1 100	3,00	5,00	4,00	5,50
1 200	4,00	6,00	4,50	6,00
1 300	5,00	7,00		7,00
1 400	6,00	8,00		8,00
1 500		9,00		9,00
1 600		10,00		10,00
1 700		11,00		11,00
1 800		12,00		

Tablica 1.3.1. Opterećenje snijegom za snježna područja i pripadajuće nadmorske visine

Opterećenje snijegom:

$$s_k = \mu_i \cdot c_e \cdot c_t \cdot s_k \text{ (kN/m}^2\text{)}$$

gdje vrijedi:

- μ_i - koeficijent oblika za opterećenje snijegom krov nagiba $0^\circ \leq \alpha \leq 30^\circ \Rightarrow \mu_i = 0,8$

- C_e - koeficijent izloženosti $\Rightarrow C_e = 1,0$

- C_t - toplinski koeficijent $\Rightarrow C_t = 1,0$

$$s_k = 0,80 \cdot 1,0 \cdot 1,0 \cdot 7,0 = 5,6 \text{ (kN/m}^2\text{)}$$

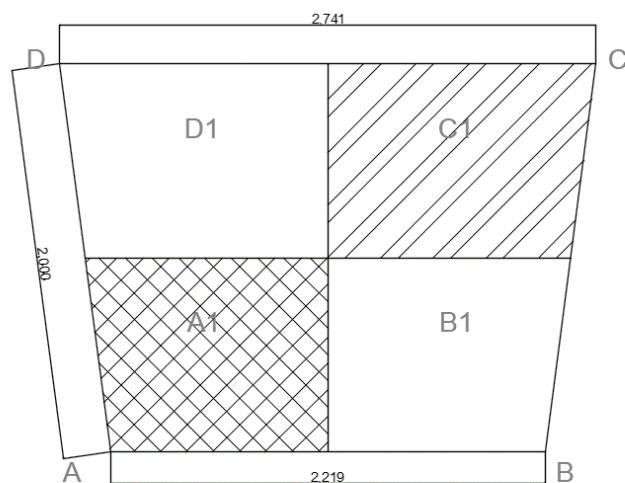
Raspored opterećenja – snijega) Pod

Slika 1.3.2. Prikaz površine poda jednog polja

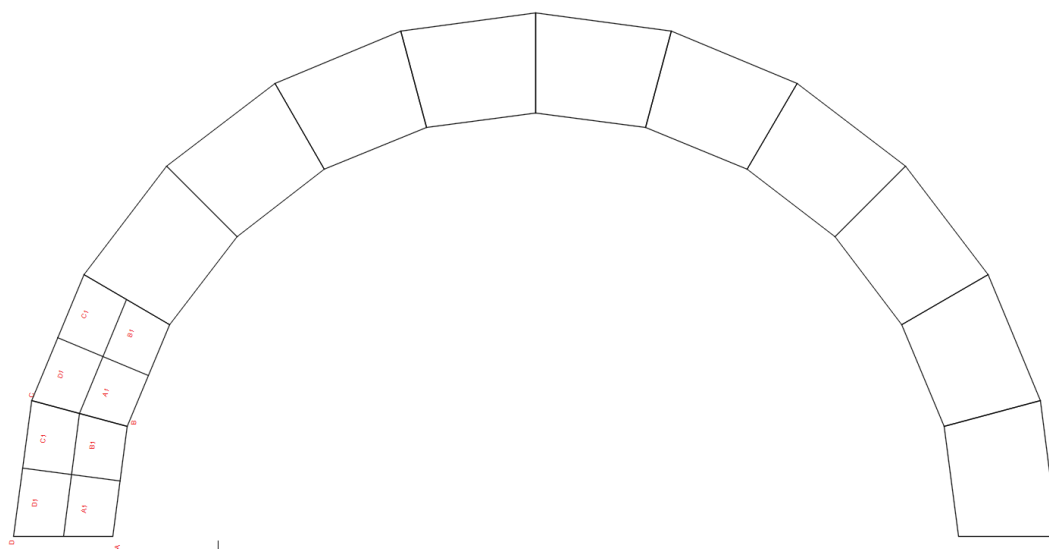

Slika 1.3.3. Tlocrtni prikaz površine poda cijele konstrukcije

$$A1=B1= 1,16747 \text{ m}^2$$

$$C1=D1= 1,29412 \text{ m}^2$$

$$S = A_{\text{sudjelujuće}} \cdot s_k$$

Za točku:

$$A \rightarrow S = A1 \cdot s_k = 1,16747 \cdot 5,6 = 6,54 \text{ kN}$$

$$B \rightarrow S = (A1 + B1) \cdot s_k = (1,16747 \cdot 2) \cdot 5,6 = 13,08 \text{ kN}$$

$$C \rightarrow S = (C1 + D1) \cdot s_k = (1,29412 \cdot 2) \cdot 5,6 = 14,50 \text{ kN}$$

$$D \rightarrow S = D1 \cdot s_k = 1,29412 \cdot 5,6 = 7,25 \text{ kN}$$

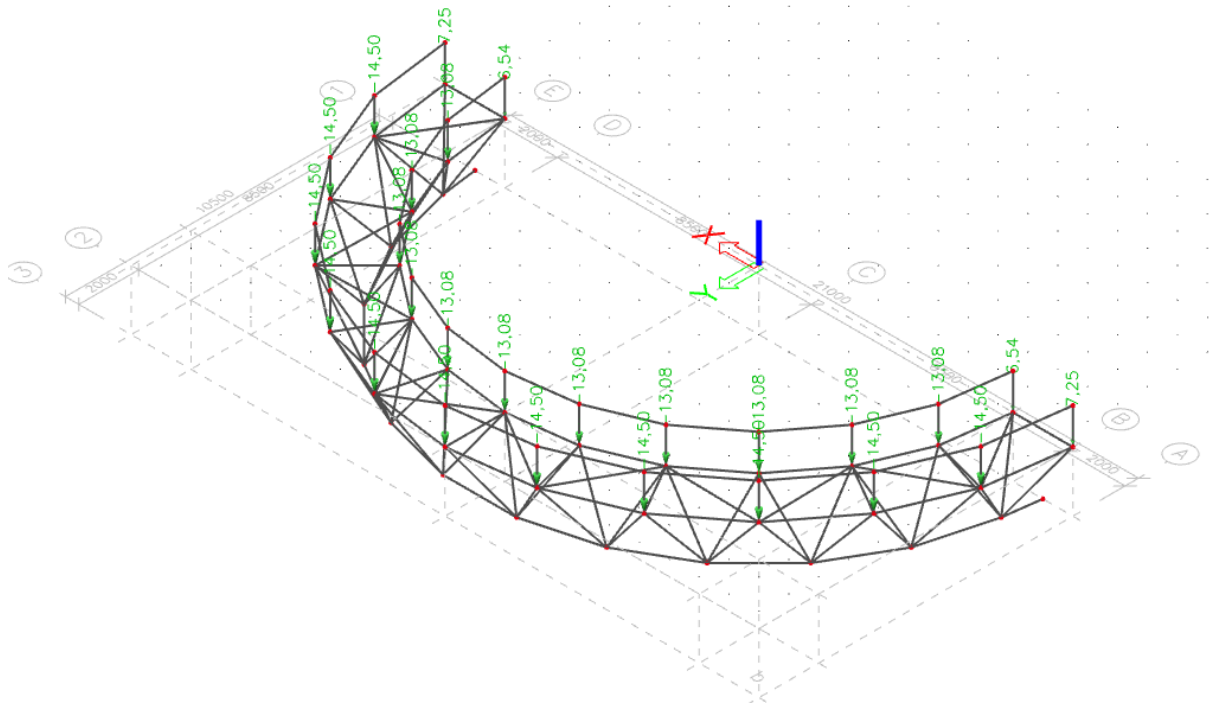

Slika 1.3.4. Prikaz opterećenja snijegom na tropojasnu čeličnu konstrukciju

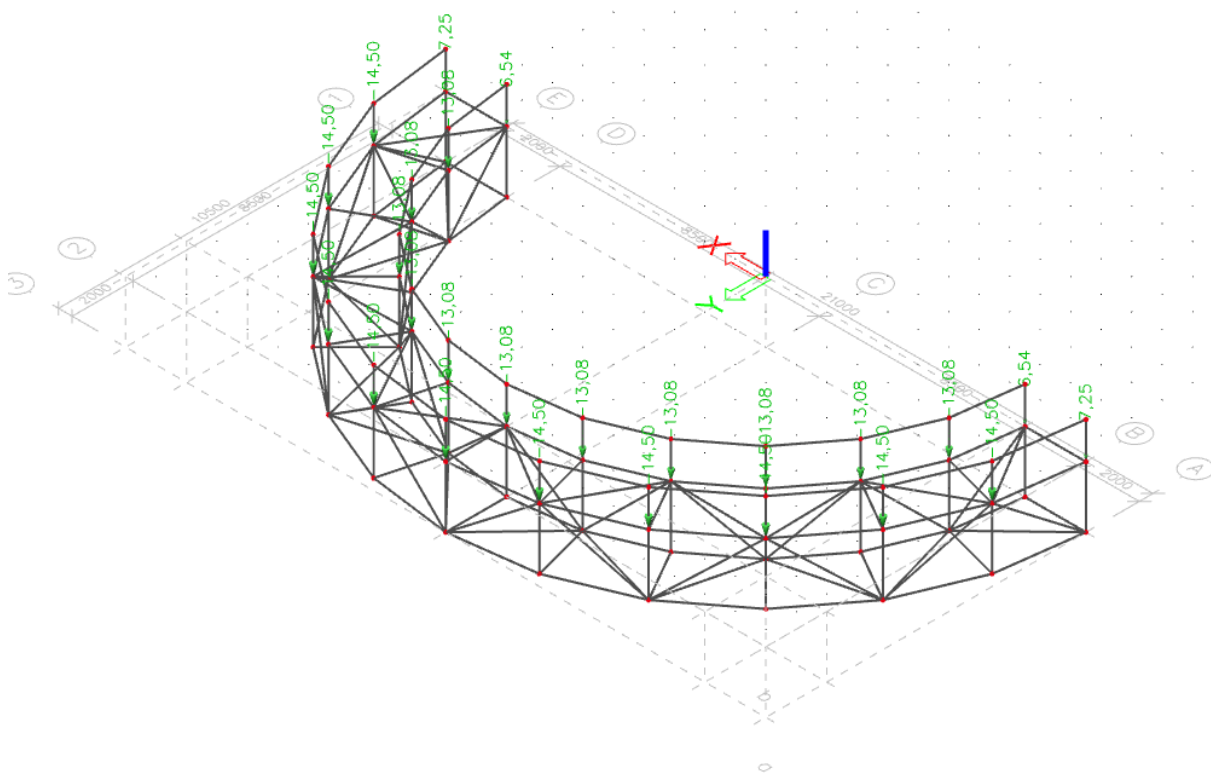

Slika 1.3.5. Prikaz opterećenja snijegom na četveropojasnu čeličnu konstrukciju

2.4. Temperaturno djelovanje

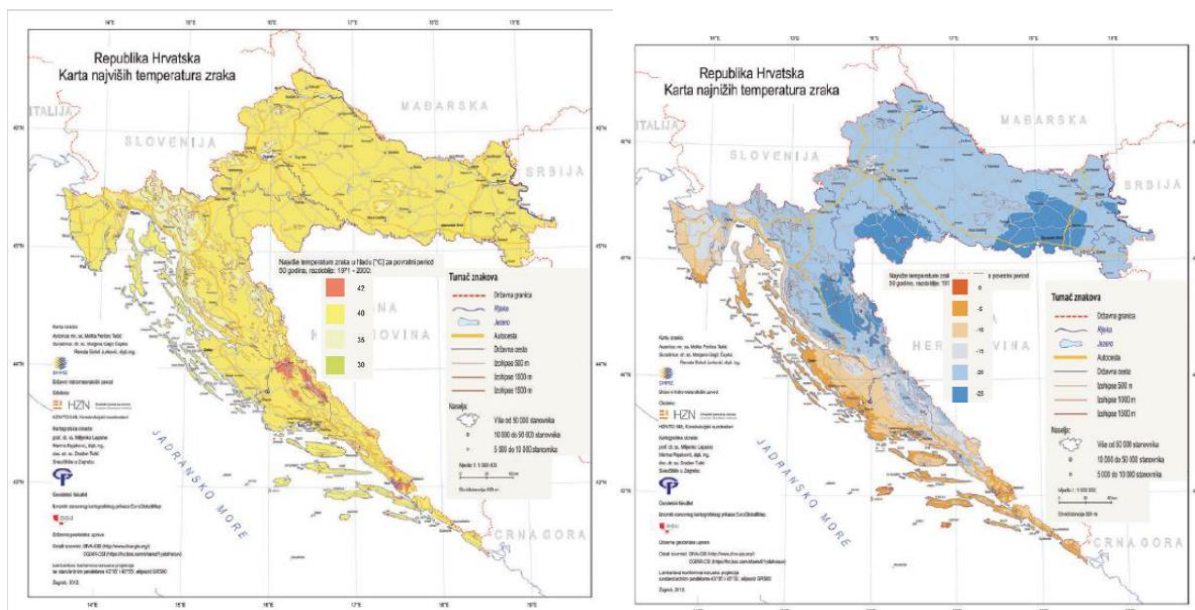

Slika 1.4.1. Zemljovid područja opterećenja temperaturom

Promatrani objekt nalazi se na području Splita do 1300 m nadmorske visine:

Najviša temperatura u hladu: $T_{\max} = 35^{\circ}\text{C}$

Najniža temperatura u hladu: $T_{\min} = -20^{\circ}\text{C}$

Pretpostavlja se djelovanje jednolike temperature promjene u svim presjecima.

Pretpostavljena temperatura pri montaži konstrukcije $T = 10^{\circ}\text{C}$

- 1) Maksimalna pozitivna temperaturna promjena: $T_{\max} = 35^{\circ}\text{C} - 10^{\circ}\text{C} = 25^{\circ}\text{C}$
- 2) Maksimalna negativna temperaturna promjena: $T_{\min} = -20^{\circ}\text{C} - 10^{\circ}\text{C} = -30^{\circ}\text{C}$

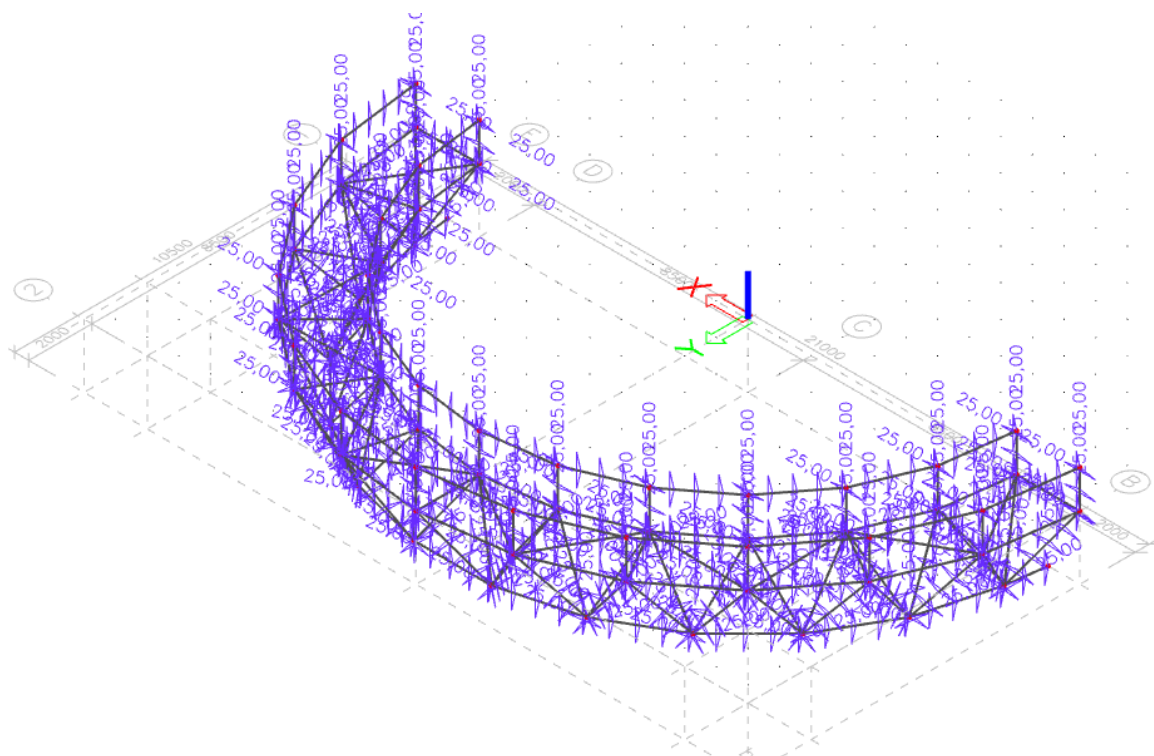

Slika 1.4.2. Prikaz opterećenja maksimalnom pozitivnom temperaturnom promjenom na tropojasnu čeličnu konstrukciju

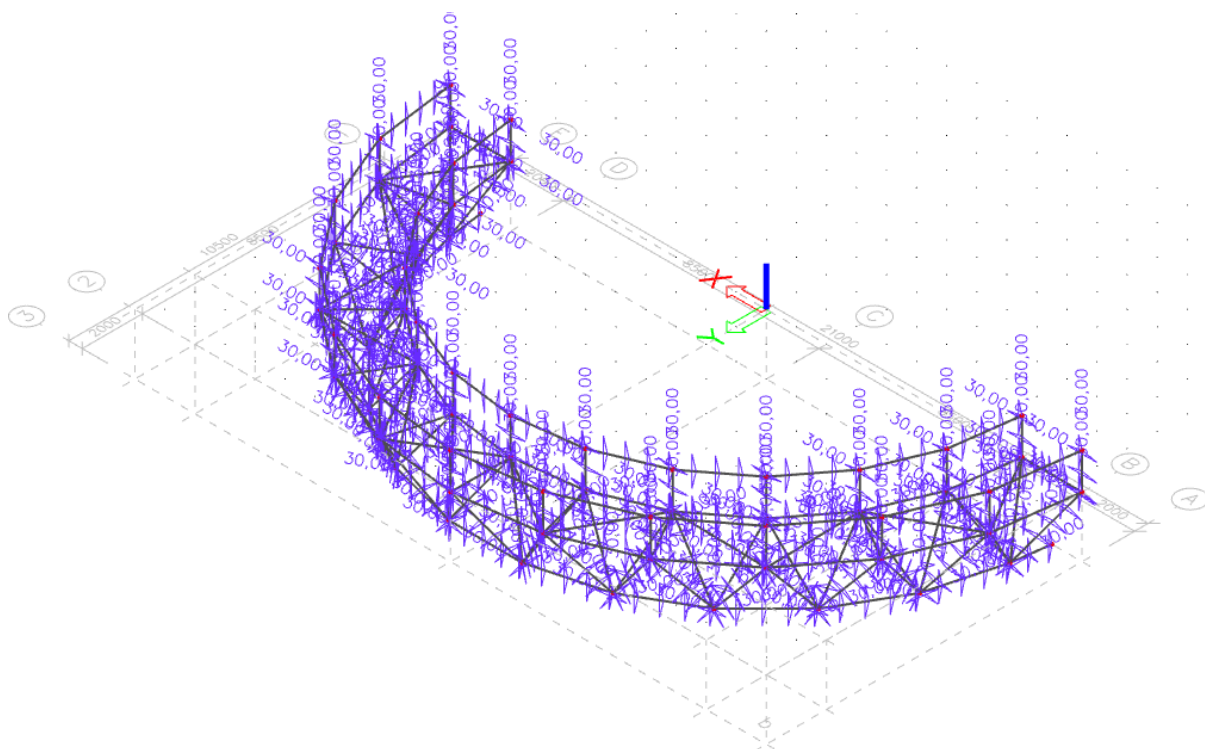

Slika 1.4.3. Prikaz opterećenja maksimalnom negativnom temperaturnom promjenom na tropojasnu čeličnu konstrukciju

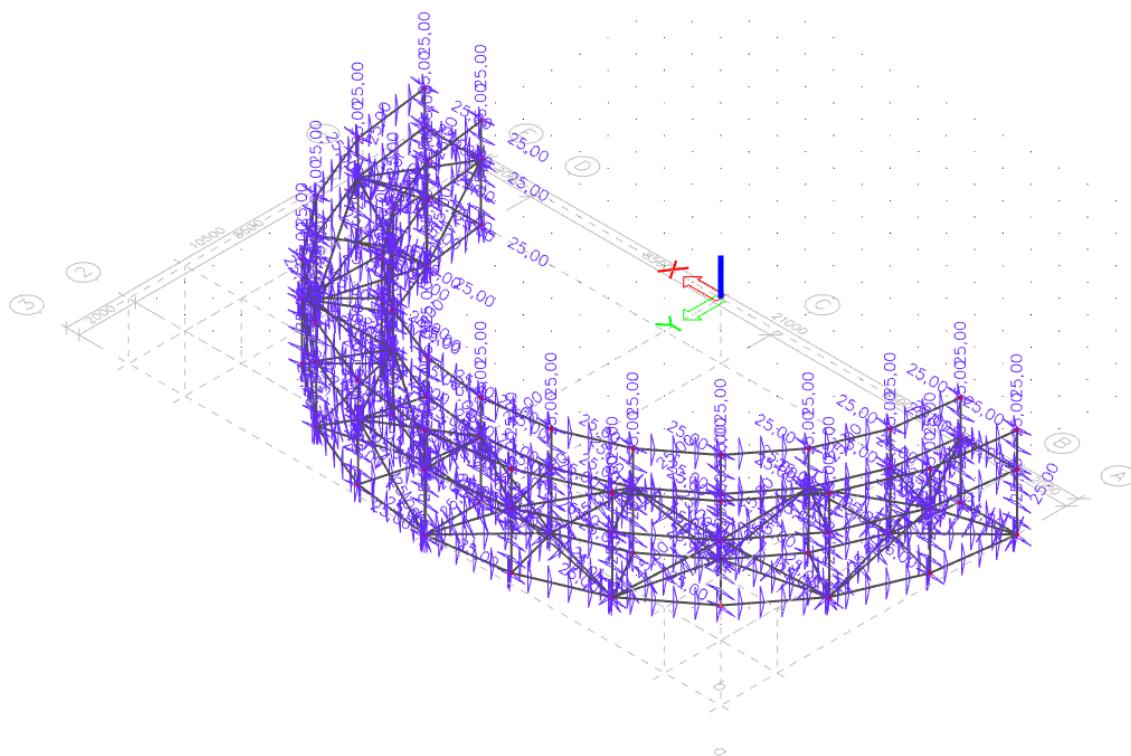

Slika 1.4.4. Prikaz opterećenja maksimalnom pozitivnom temperaturnom promjenom na četveropojasnu čeličnu konstrukciju

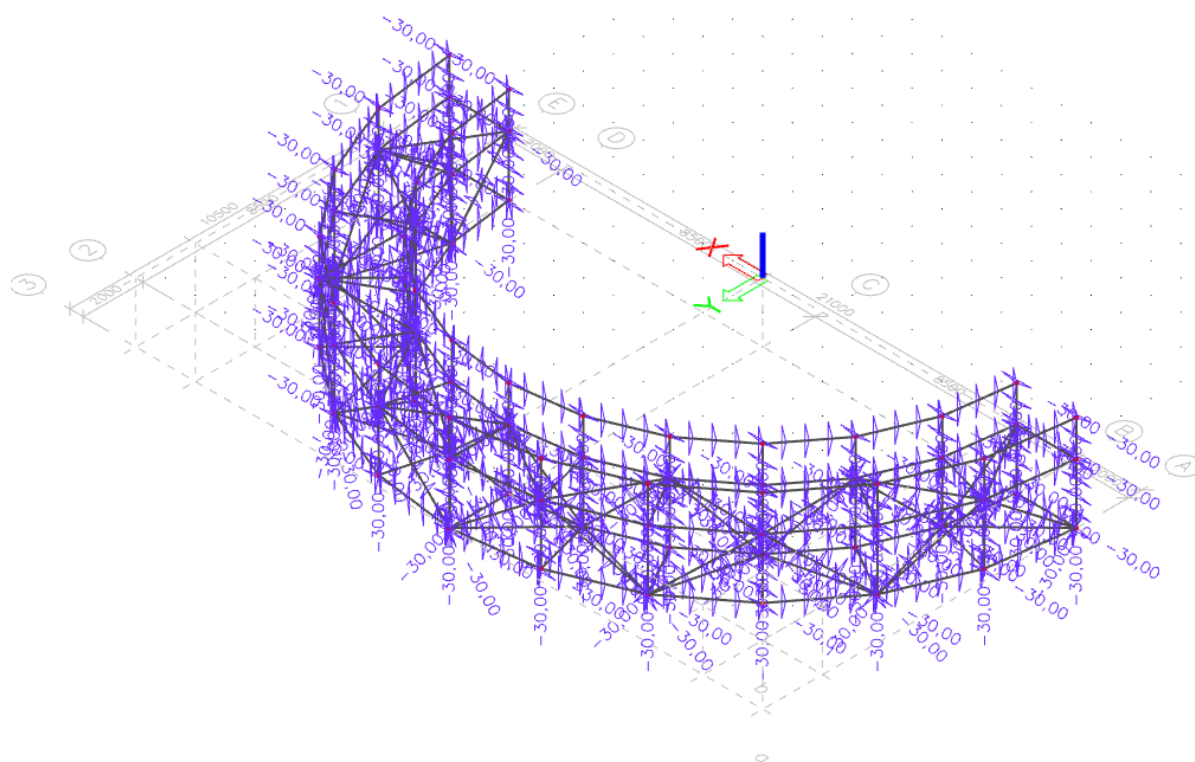

Slika 1.4.5. Prikaz opterećenja maksimalnom negativnom temperaturnom promjenom na četveropojasnu čeličnu konstrukciju

2.5. Prometno opterećenje (pješaci)

Dinamički učinci tretirani su kao statički. Navala pješaka na cijelom rasponu konstrukcije zaseban je model opterećenja ($q_{fk} = 5,0 \text{ kN/m}^2$)

Raspored opterećenja u čvorove

(Površine su definirane za prethodno opterećenje snijegom)

$$P = A_{\text{sudjelujuće}} \cdot q_{fk}$$

Za točku:

$$A \rightarrow P = A1 \cdot q_{fk} = 1,16747 \cdot 5,0 = 5,84 \text{ kN}$$

$$B \rightarrow P = (A1 + B1) \cdot q_{fk} = (1,16747 \cdot 2) \cdot 5,0 = 11,68 \text{ kN}$$

$$C \rightarrow P = (C1 + D1) \cdot q_{fk} = (1,29412 \cdot 2) \cdot 5,0 = 12,94 \text{ kN}$$

$$D \rightarrow P = D1 \cdot q_{fk} = 1,29412 \cdot 5,0 = 6,47 \text{ kN}$$

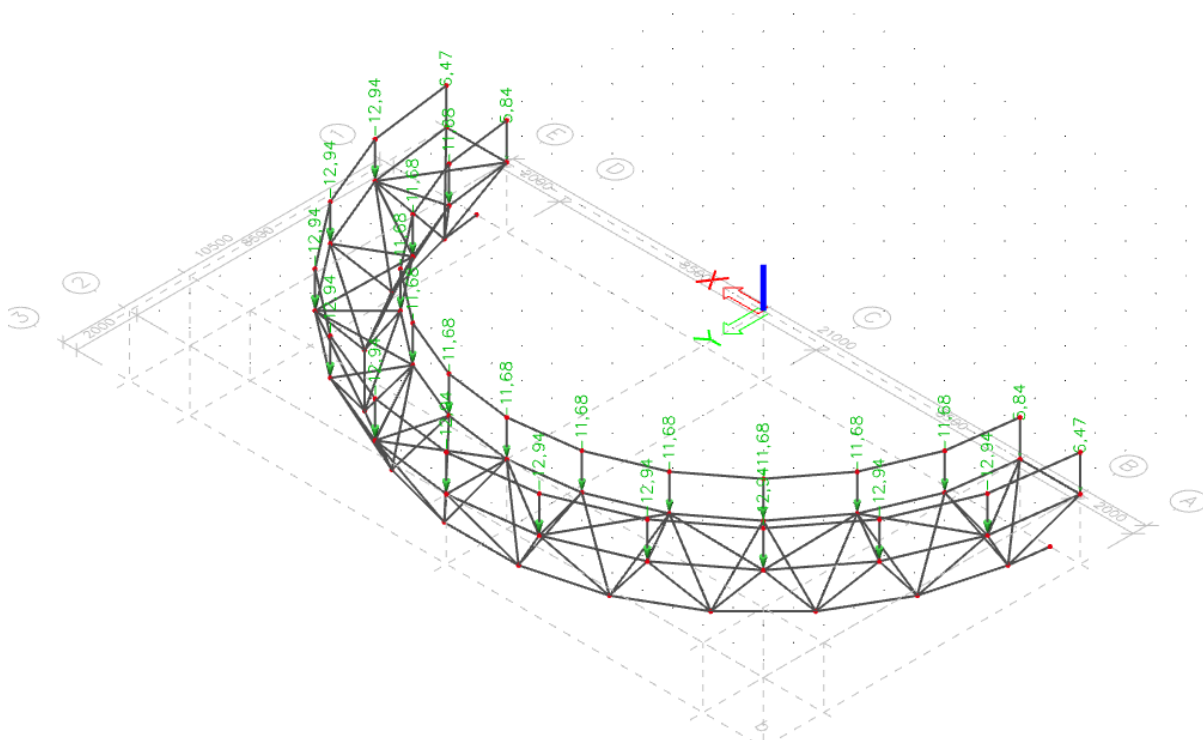

Slika 1.5.1. Prikaz prometnog opterećenja na trobojasnu čeličnu konstrukciju

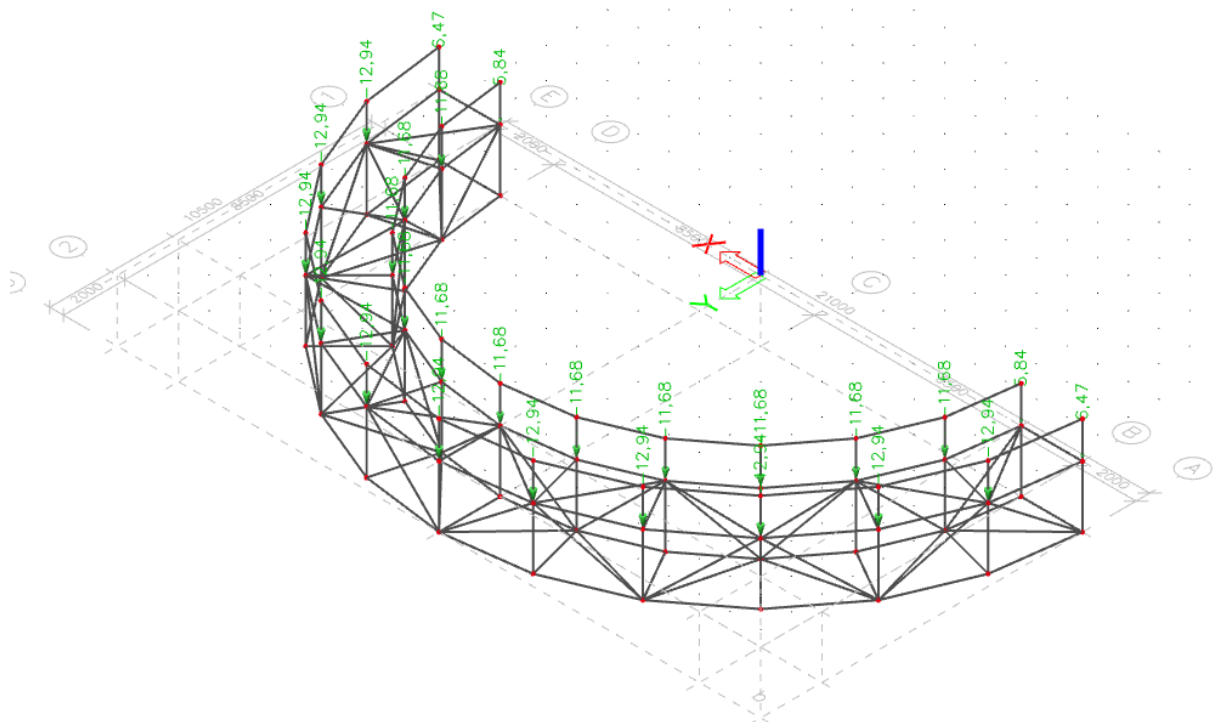

Slika 1.5.2. Prikaz prometnog opterećenja na četveropojasnu čeličnu konstrukciju

3. KOMBINACIJE OPTEREĆENJA ZA ČELIČNU KONSTRUKCIJU

3.1. Dijagrami reznih sila za kombinacije djelovanja kod tropojasne rešetke

3.1.1. Kombinacija djelovanja 1

$$K_1 = 1,35 \cdot V.T + 1,5 \cdot S + 0,3 \cdot F_w + 0,6 \cdot T_{\min}$$

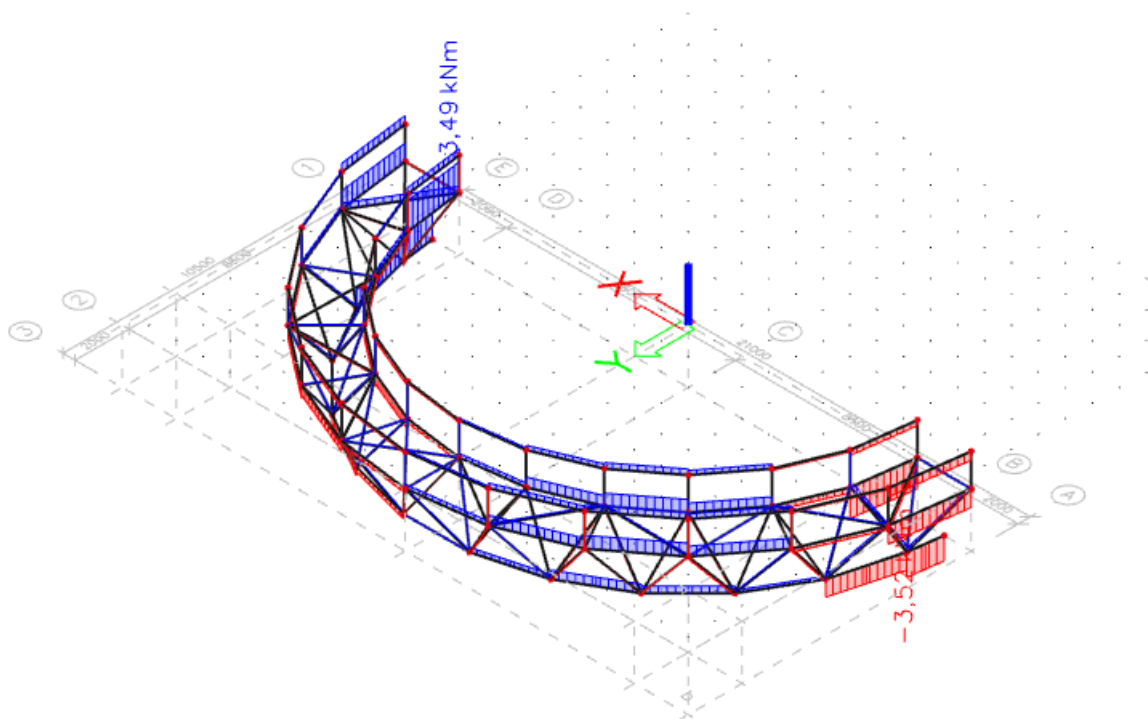

Slika. 2.1.1.1. Momentni dijagram opterećenja kombinacije 1 – Mx (kNm)

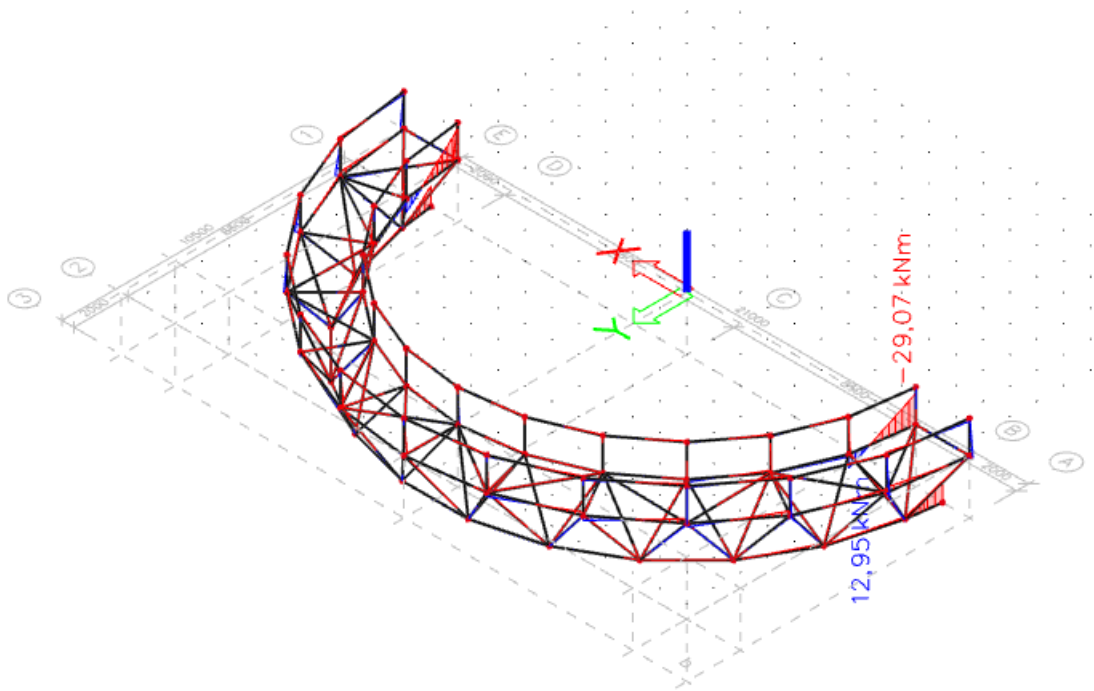

Slika. 2.1.1.2. Momentni dijagram opterećenja kombinacije 1 – M_y (kNm)

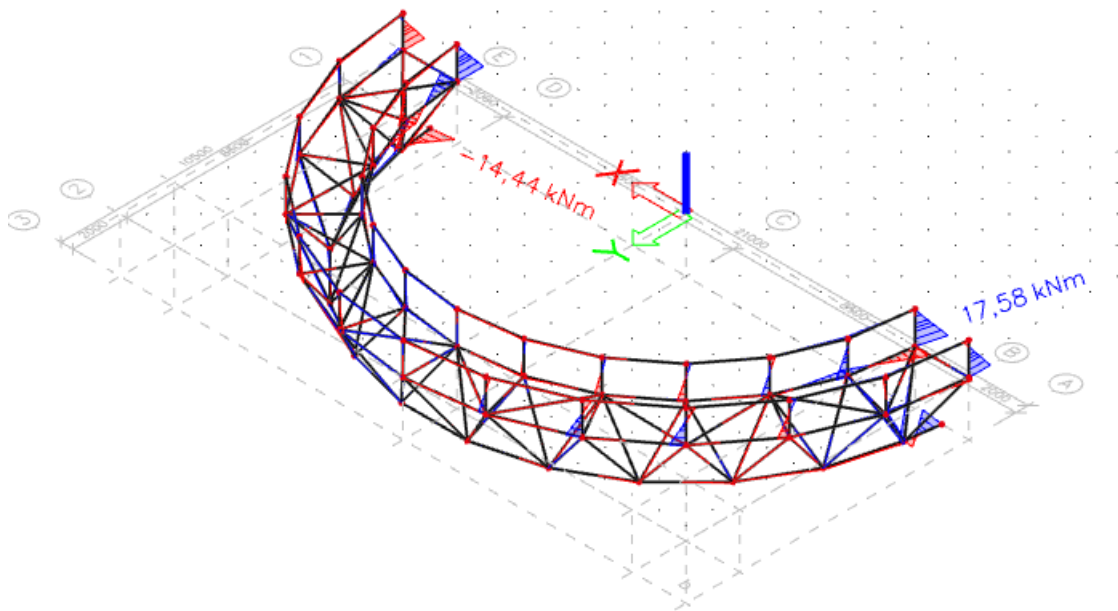

Slika. 2.1.1.3. Momentni dijagram opterećenja kombinacije 1 – M_z (kNm)

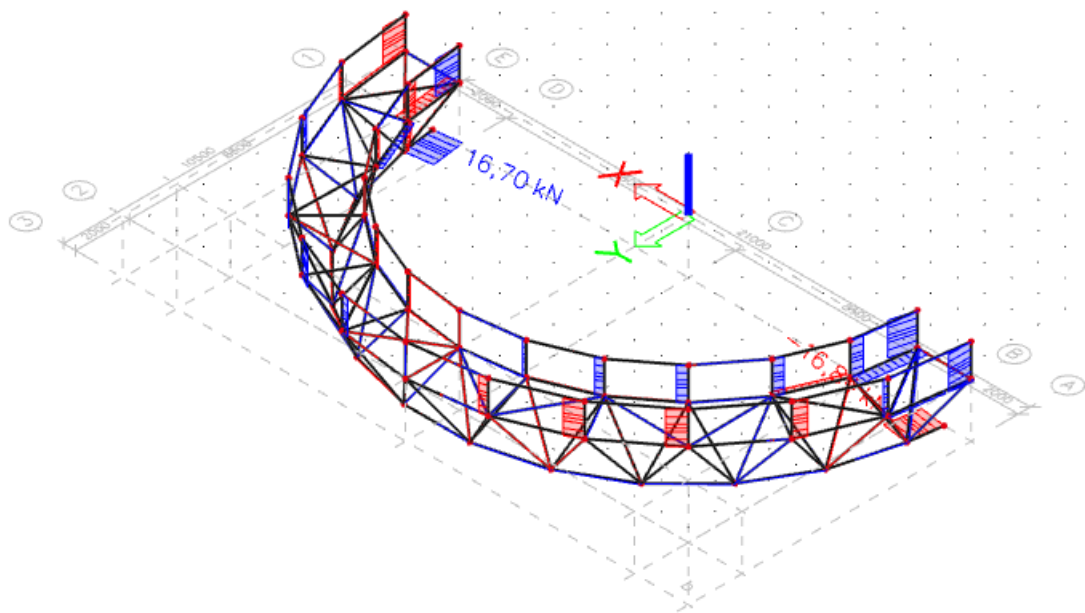

Slika. 2.1.1.4. Dijagram poprečnih sila opterećenja kombinacije 1 – V_y (kN)

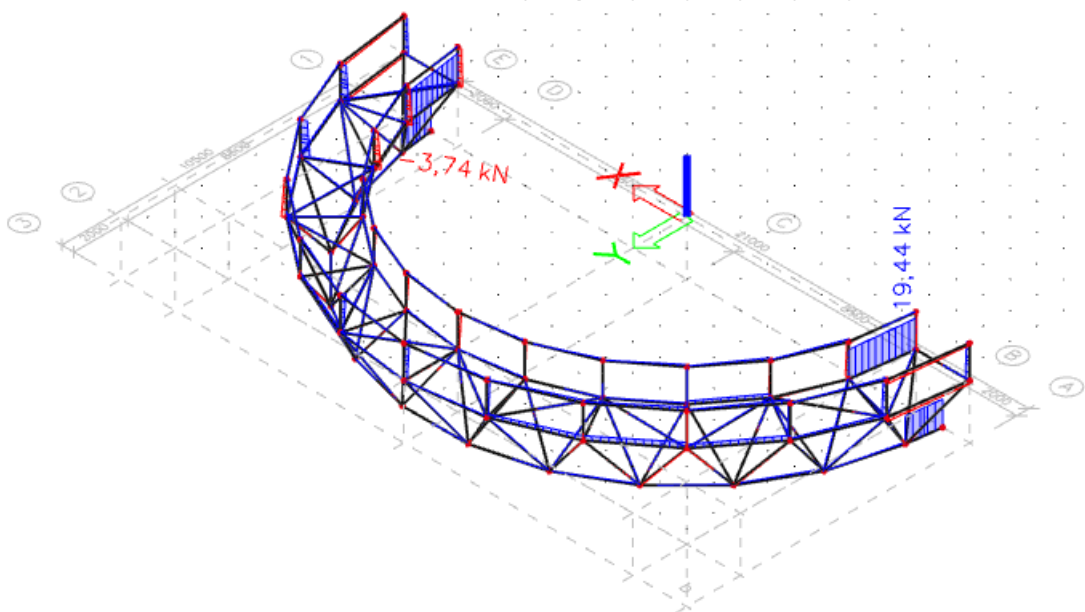

Slika. 2.1.1.5. Dijagram poprečnih sila opterećenja kombinacije 1 – V_z (kN)

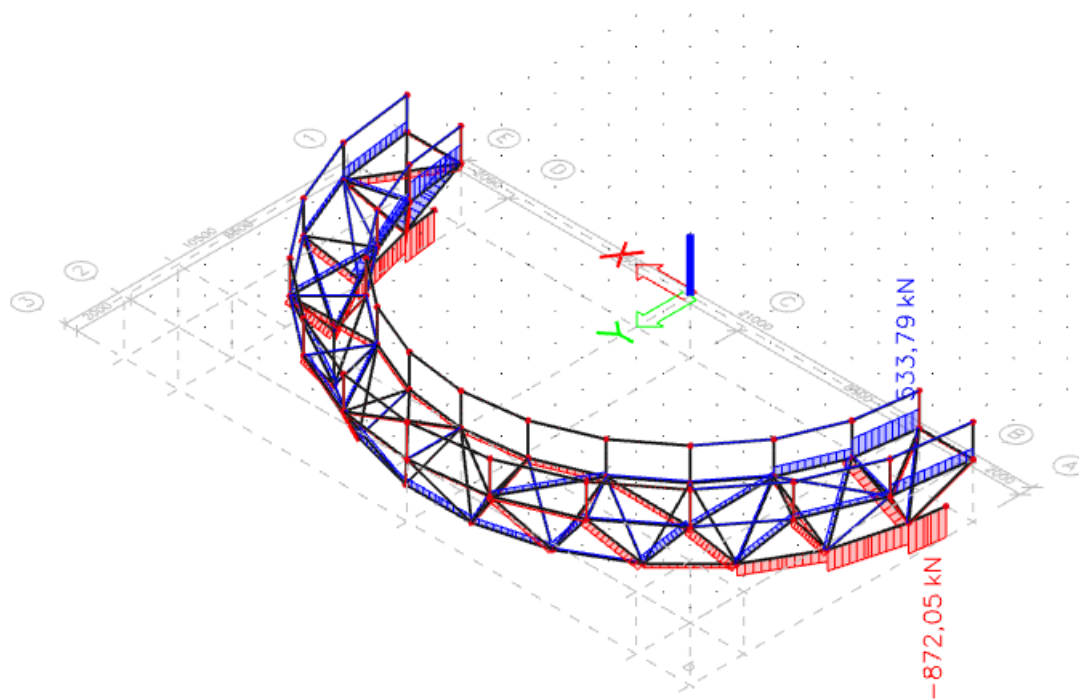

Slika. 2.1.1.6. Dijagram uzdužnih sila opterećenja kombinacije 1 – N (kN)

3.1.2. Kombinacija djelovanja 2

$$K_2 = 1,35 \cdot V.T + 1,5 \cdot P + 0,3 \cdot F_w + 0,6 \cdot T_{\max}$$

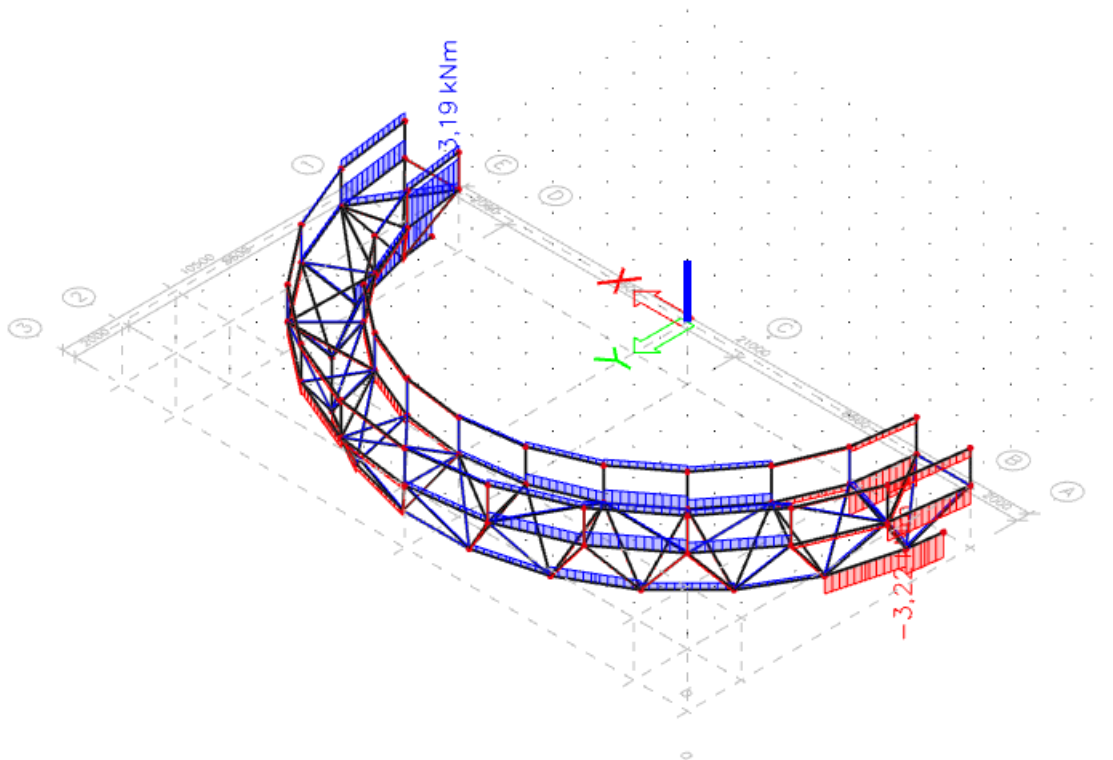

Slika 2.1.2.1. Momentni dijagram opterećenja kombinacije 2 – Mx (kNm)

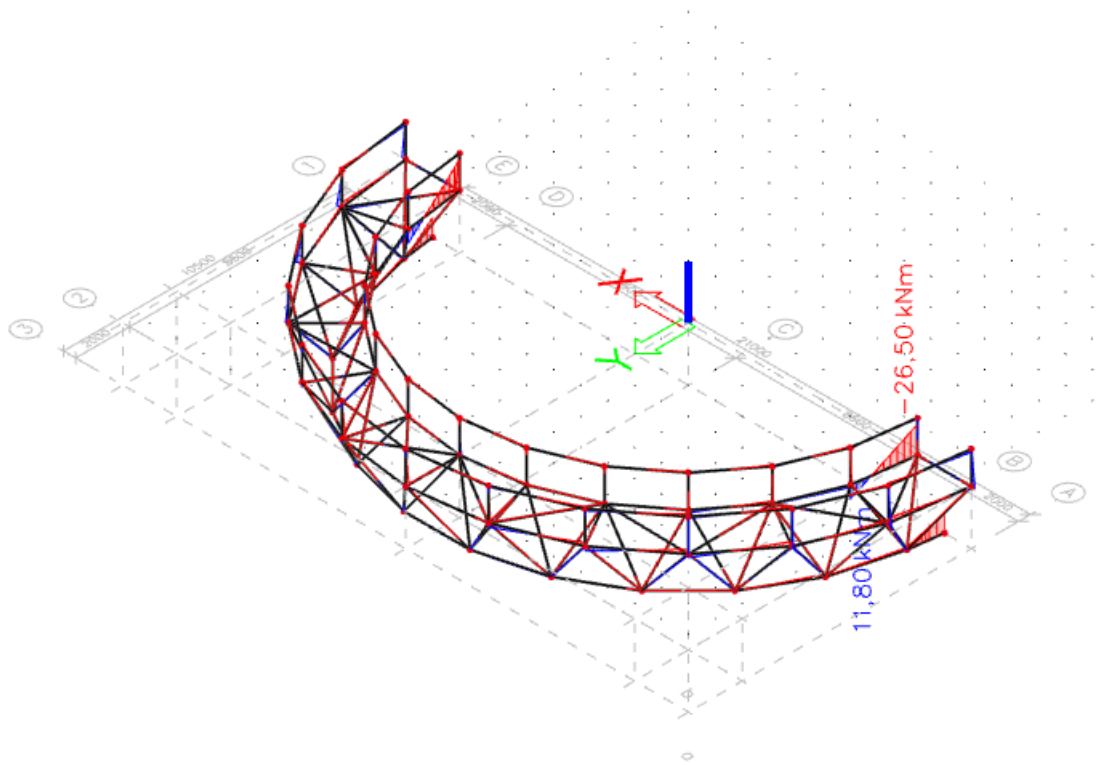

Slika 2.1.2.2. Momentni dijagram opterećenja kombinacije 2 – M_y (kNm)

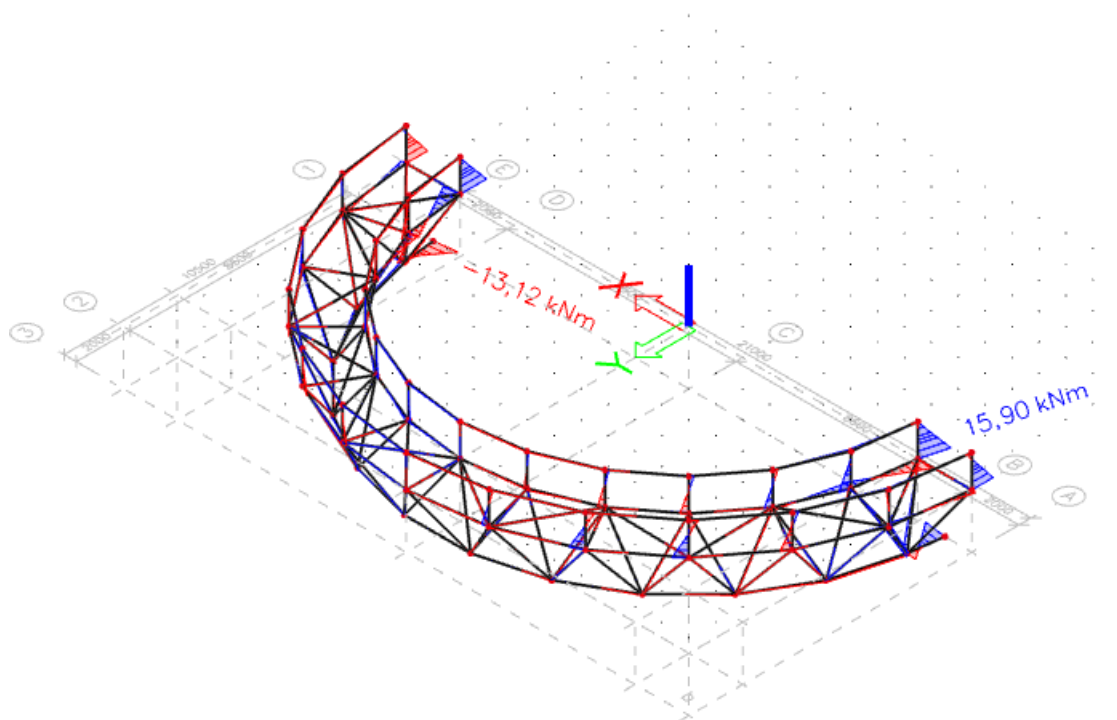

Slika 2.1.2.3. Momentni dijagram opterećenja kombinacije 2 – M_y (kNm)

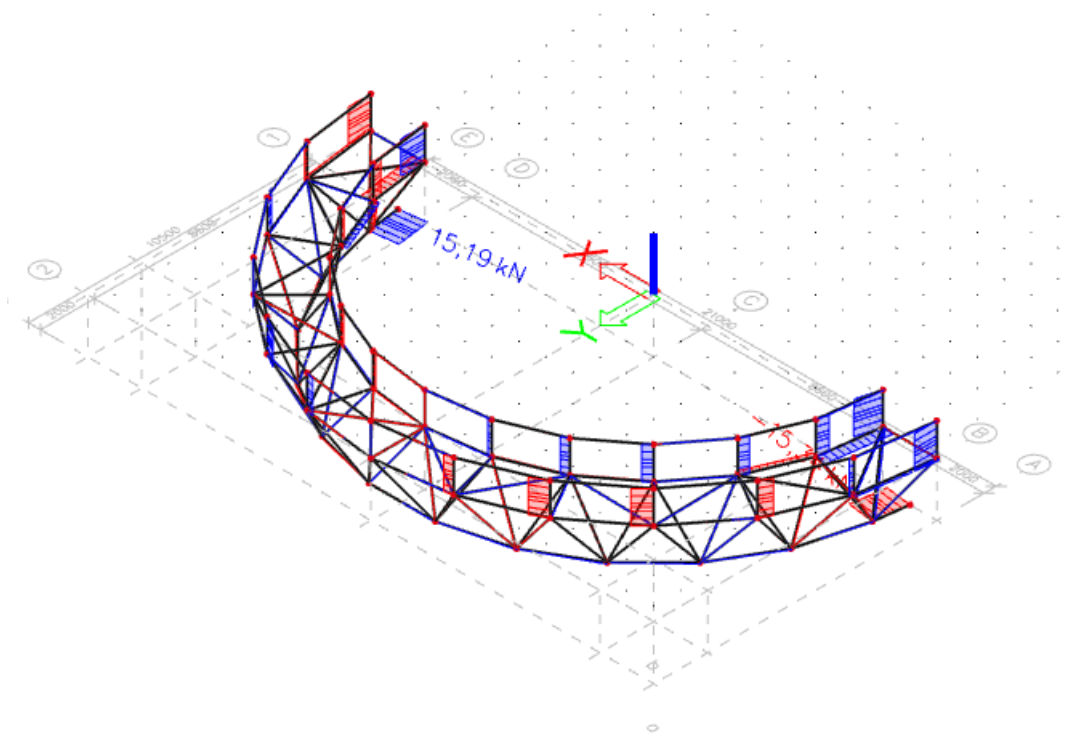

Slika 2.1.2.4. Dijagram poprečnih sila opterećenja kombinacije 2 – V_y (kN)

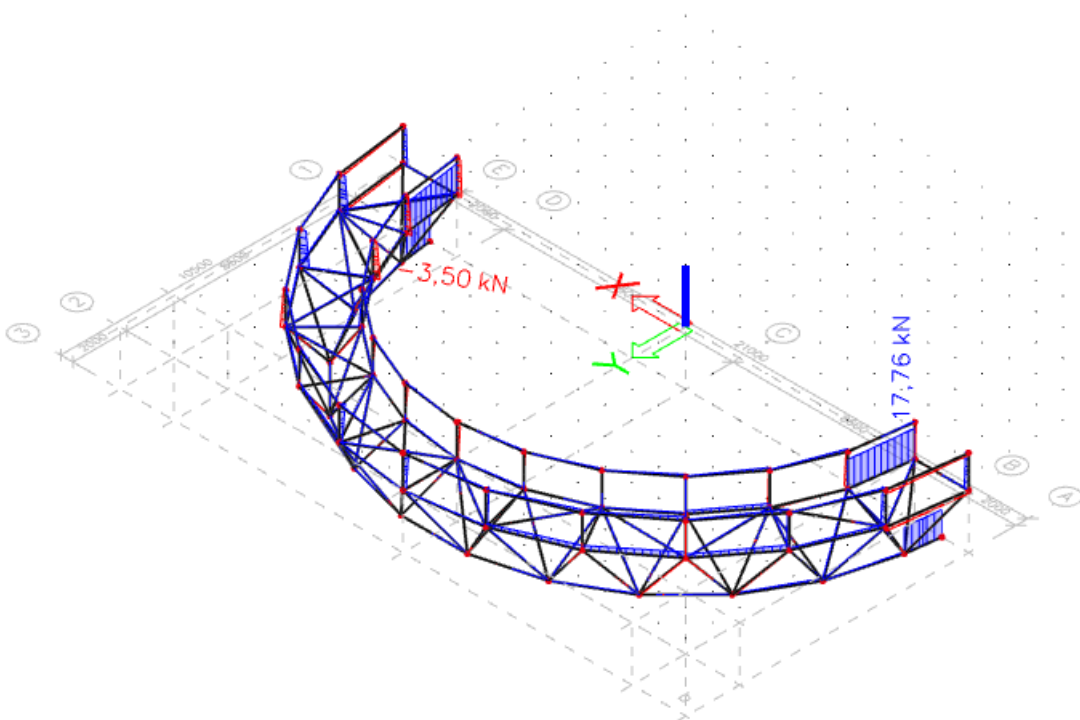

Slika 2.1.2.5. Dijagram poprečnih sila opterećenja kombinacije 2 – V_z (kN)

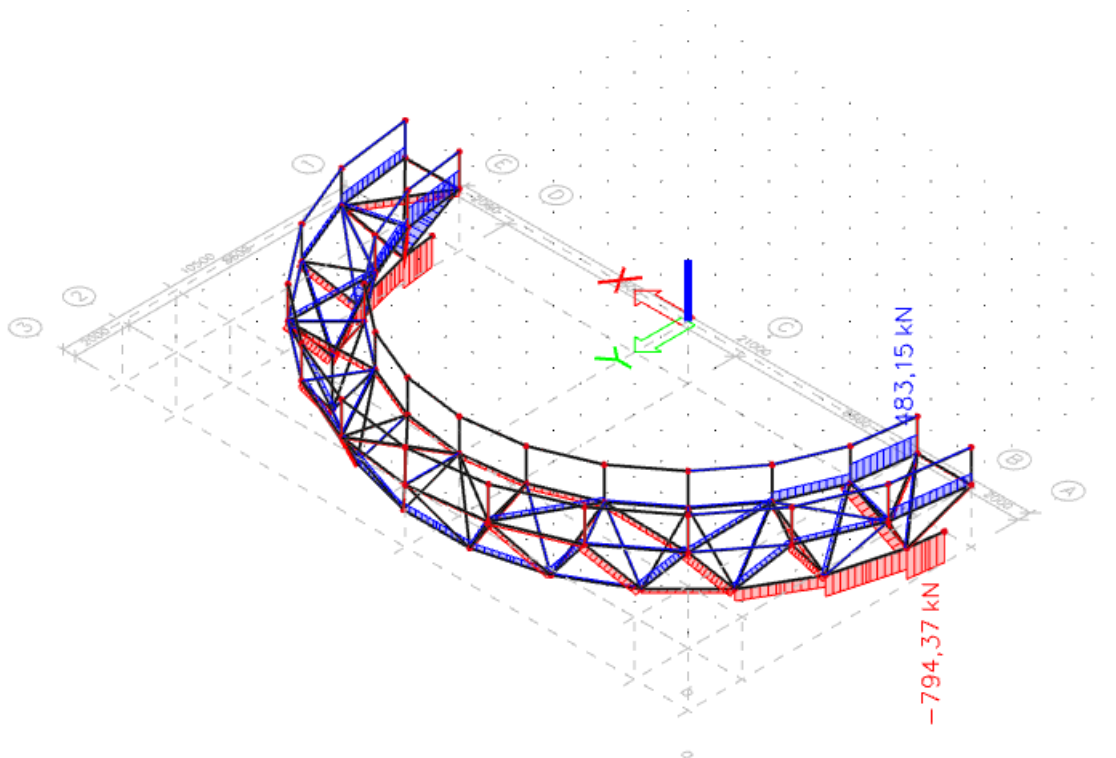

Slika 2.1.2.6. Dijagram uzdužnih sila opterećenja kombinacije 2 – N (kN)

3.1.3. Kombinacija djelovanja 3

$$K_3 = 1,35 \cdot V.T + 0,8 \cdot S + 1,5 \cdot F_w + 0,6 \cdot T_{\min}$$

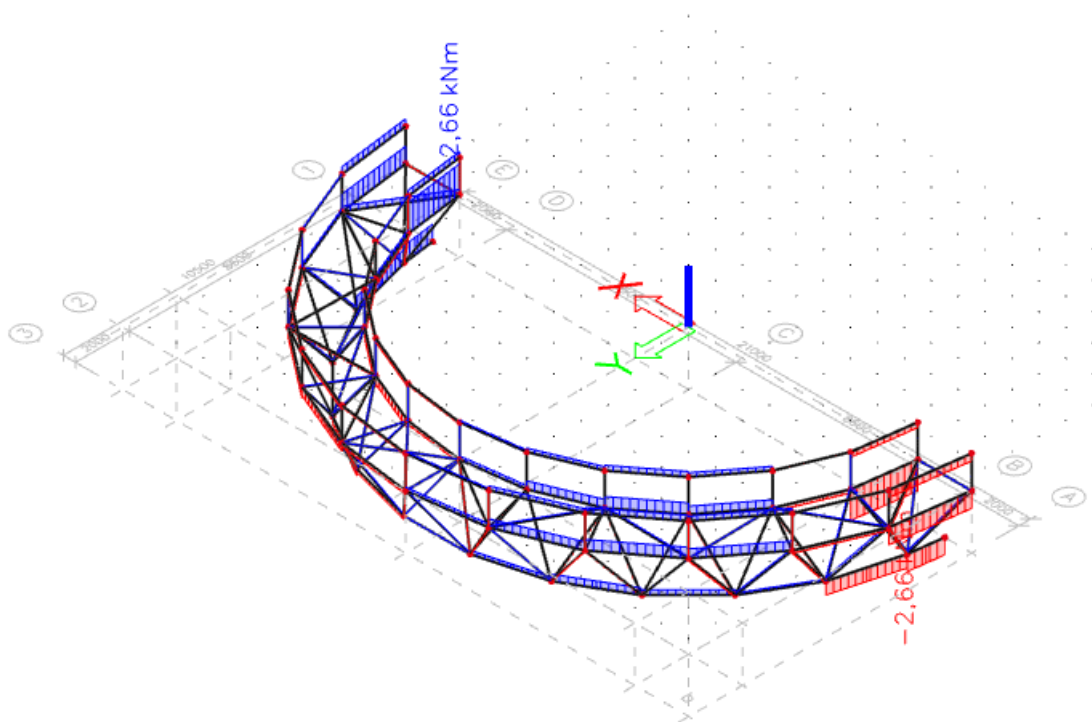

Slika 2.1.3.1. Momentni dijagram opterećenja kombinacije 3 – Mx (kNm)

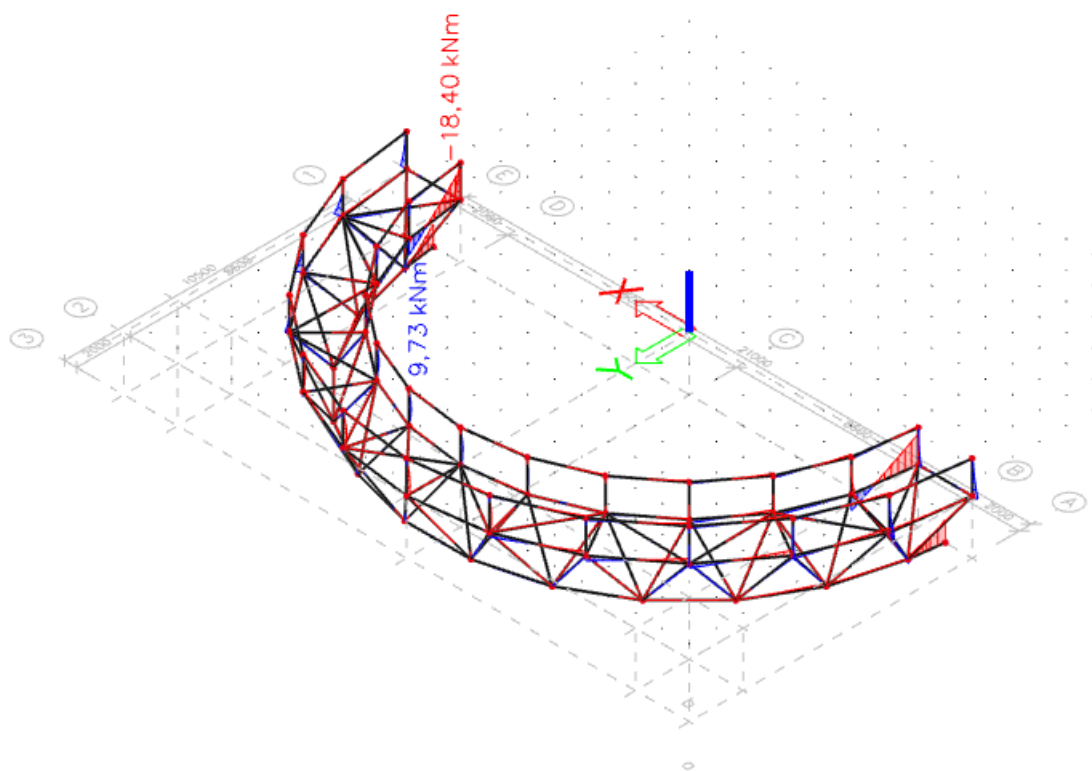

Slika 2.1.3.2. Momentni dijagram opterećenja kombinacije 3 – M_y (kNm)

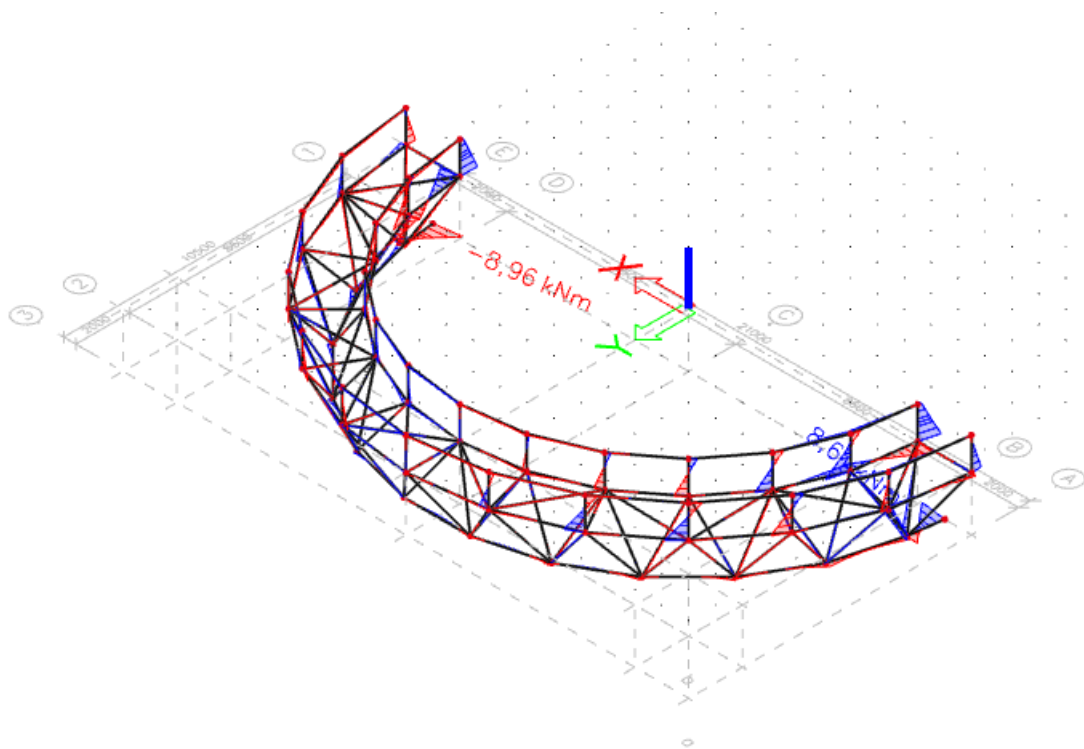

Slika 2.1.3.3. Momentni dijagram opterećenja kombinacije 3 – M_z (kNm)

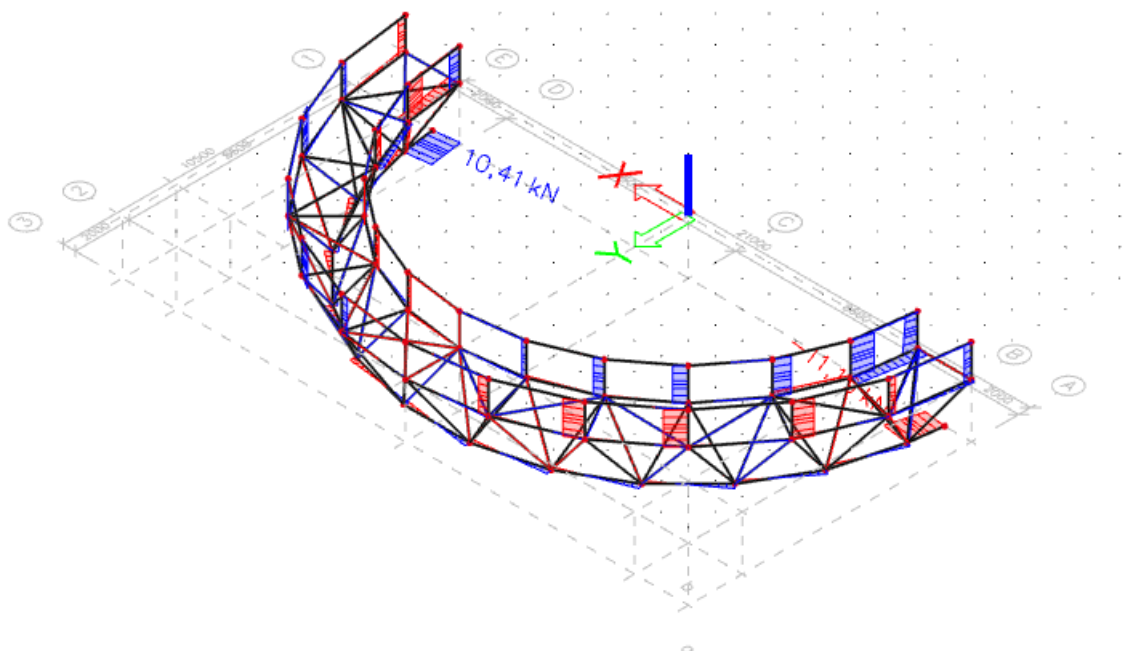

Slika 2.1.3.4. . Dijagram poprečnih sila opterećenja kombinacije 3 – V_y (kN)

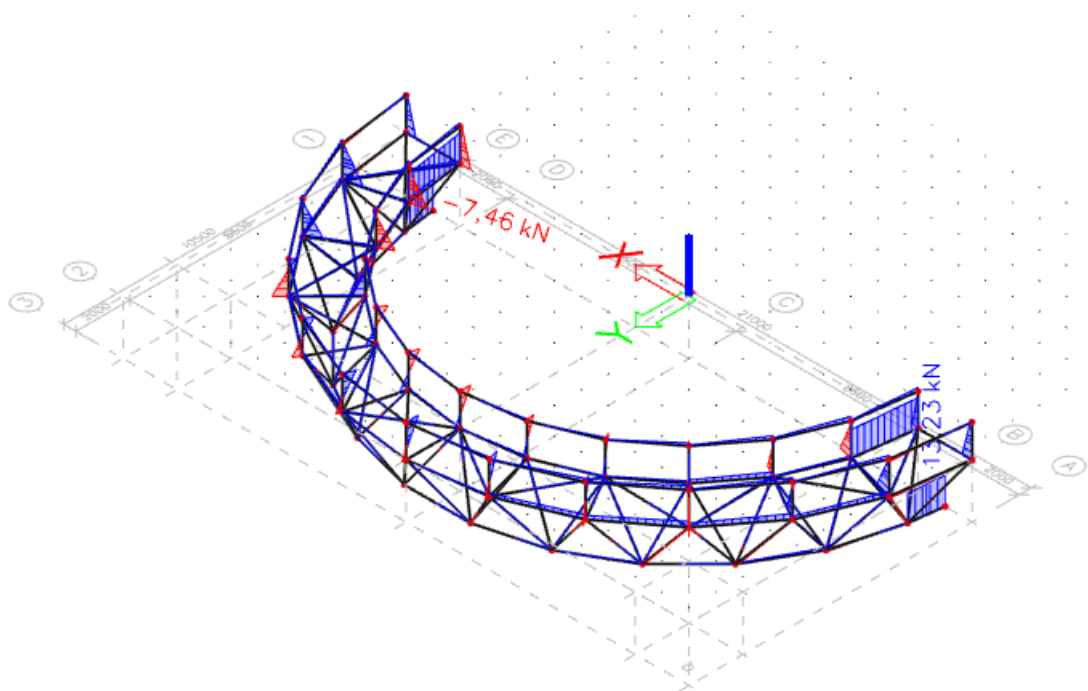

Slika 2.1.3.5. Dijagram poprečnih sila opterećenja kombinacije 3 – V_z (kN)

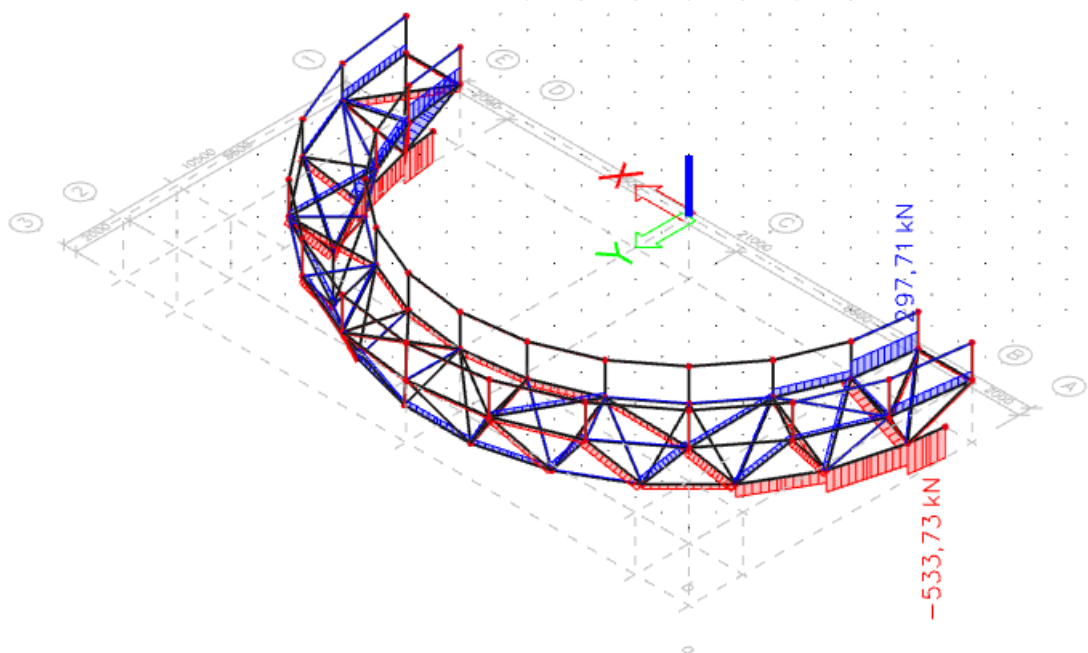

Slika 2.1.3.6. Dijagram uzdužnih sila opterećenja kombinacije 3 – N (kN)

3.1.4. Kombinacija djelovanja 4

$$K_4 = 1,35 \cdot V.T + 0,4 \cdot P + 1,5 \cdot F_w + 0,6 \cdot T_{\max}$$

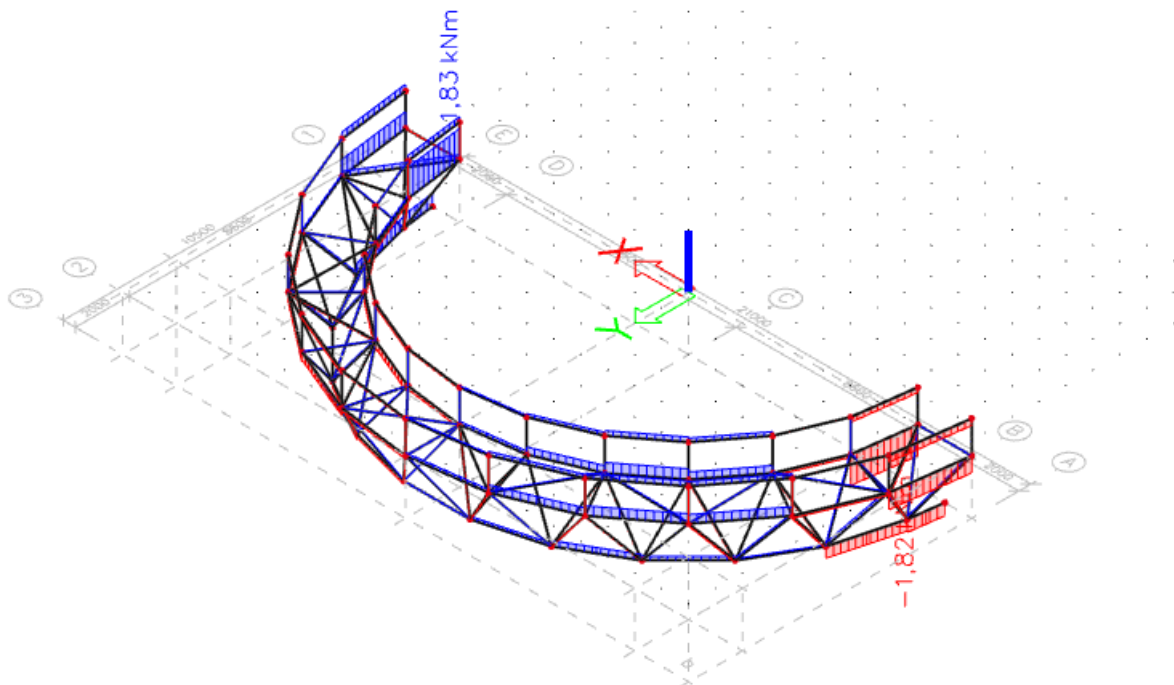

Slika 2.1.4.1. Momentni dijagram opterećenja kombinacije 4 – M_x (kNm)

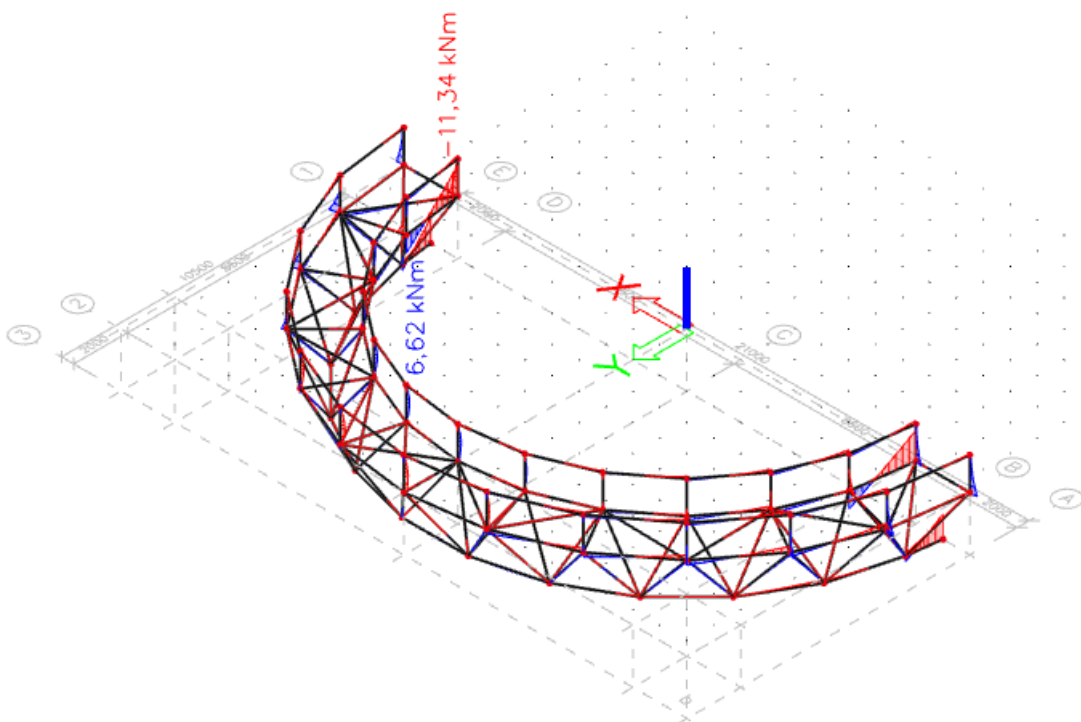

Slika 2.1.4.2. Momentni dijagram opterećenja kombinacije 4 – M_y (kNm)

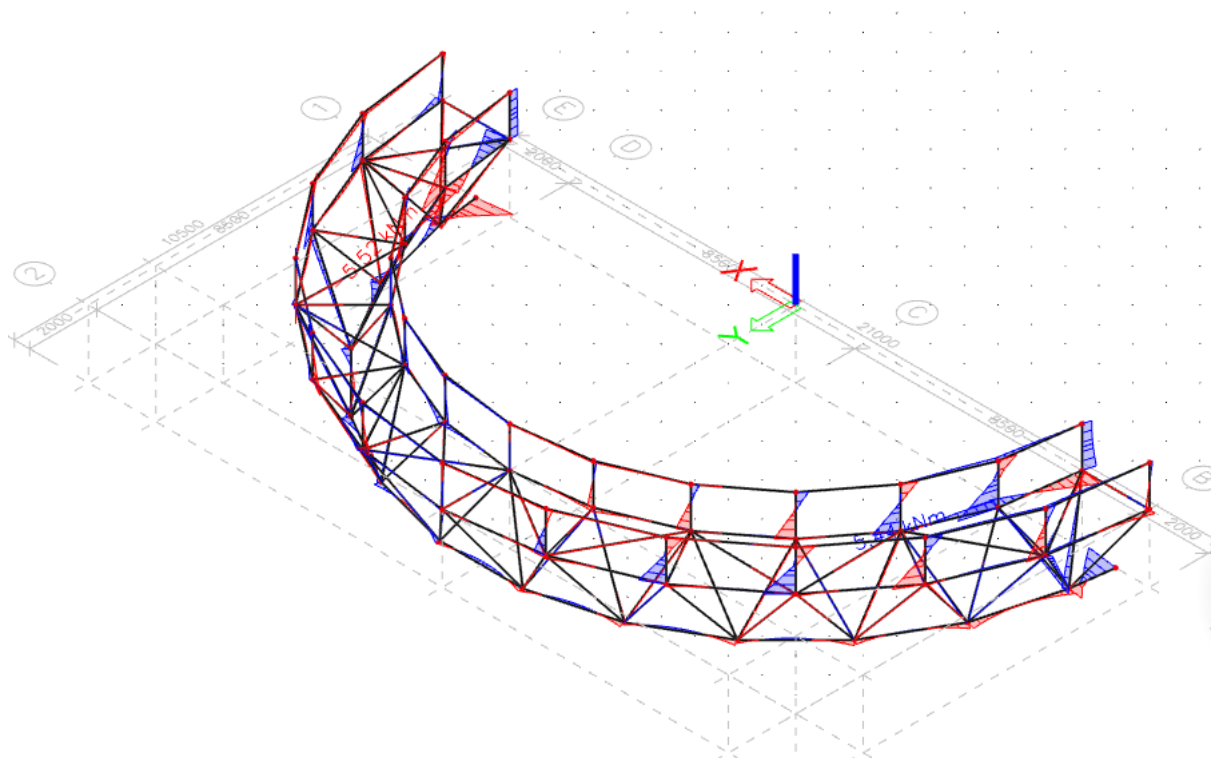

Slika 2.1.4.3. Momentni dijagram opterećenja kombinacije 4 – M_z (kNm)

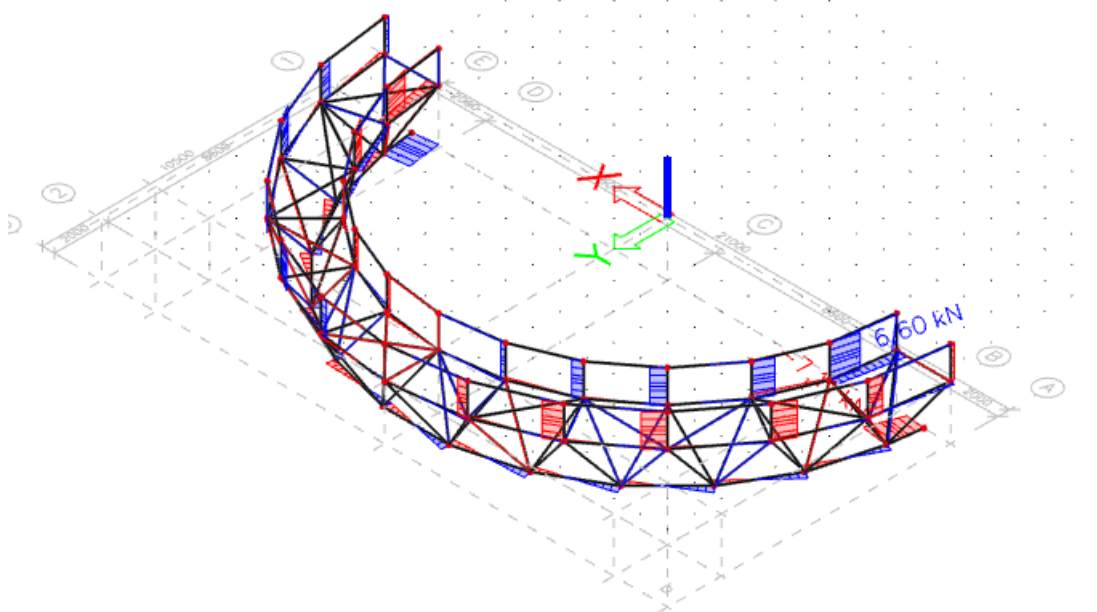

Slika 2.1.4.4. Dijagram poprečnih sila opterećenja kombinacije 4 – V_y (kN)

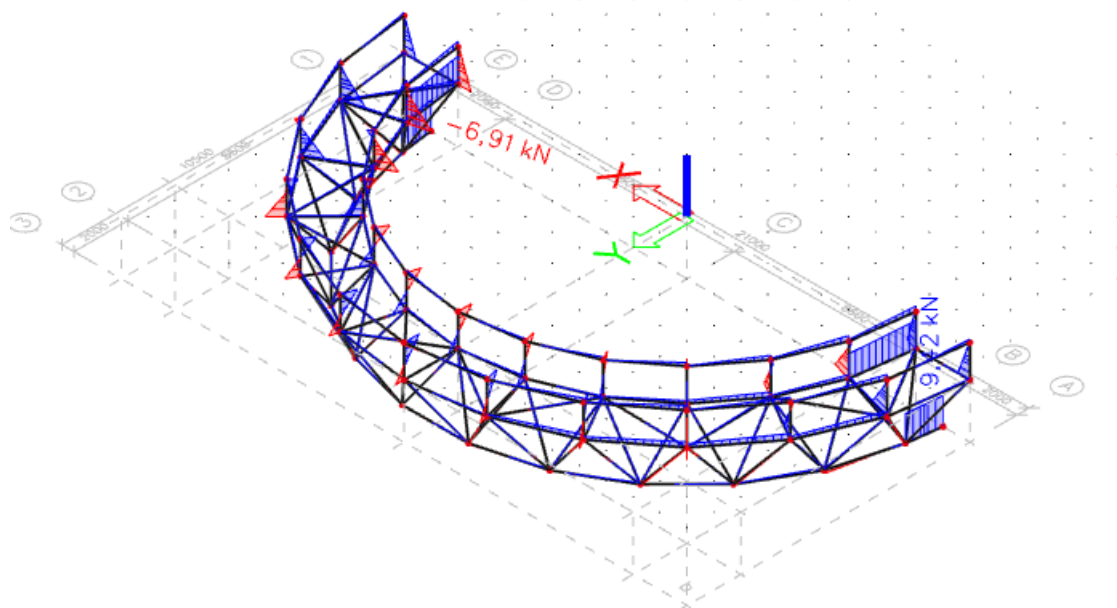

Slika 2.1.4.5. Dijagram poprečnih sila opterećenja kombinacije 4 – Vz (kN)

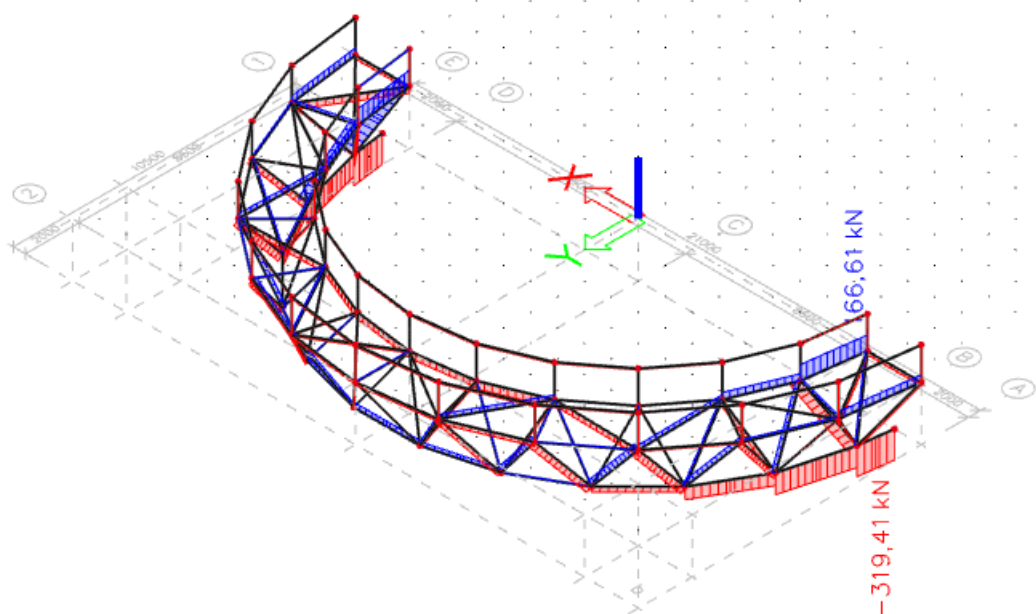

Slika 2.1.4.6. Dijagram uzdužnih sila opterećenja kombinacije 4 – N (kN)

3.1.5. Kombinacija djelovanja 5

$$K_5 = 1,35 \cdot V.T + 0,4 \cdot P + 0,3 \cdot F_w + 1,5 \cdot T_{\max}$$

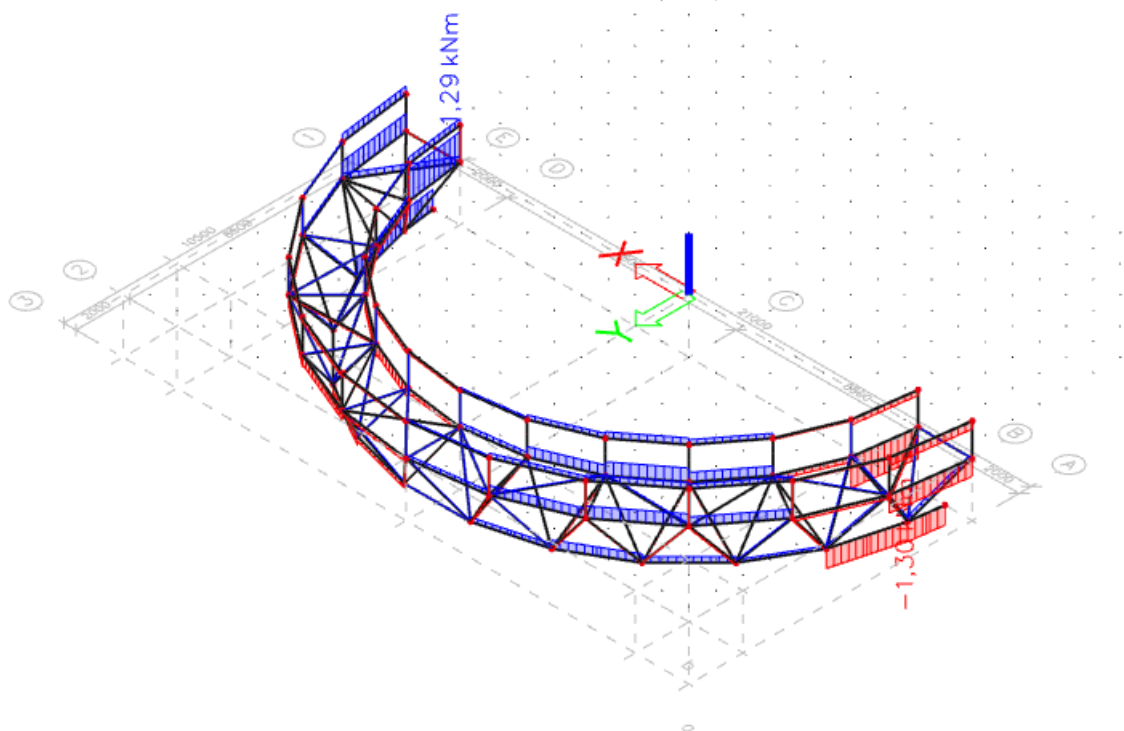

Slika 2.1.5.1. Momentni dijagram opterećenja kombinacije 5 – Mx (kNm)

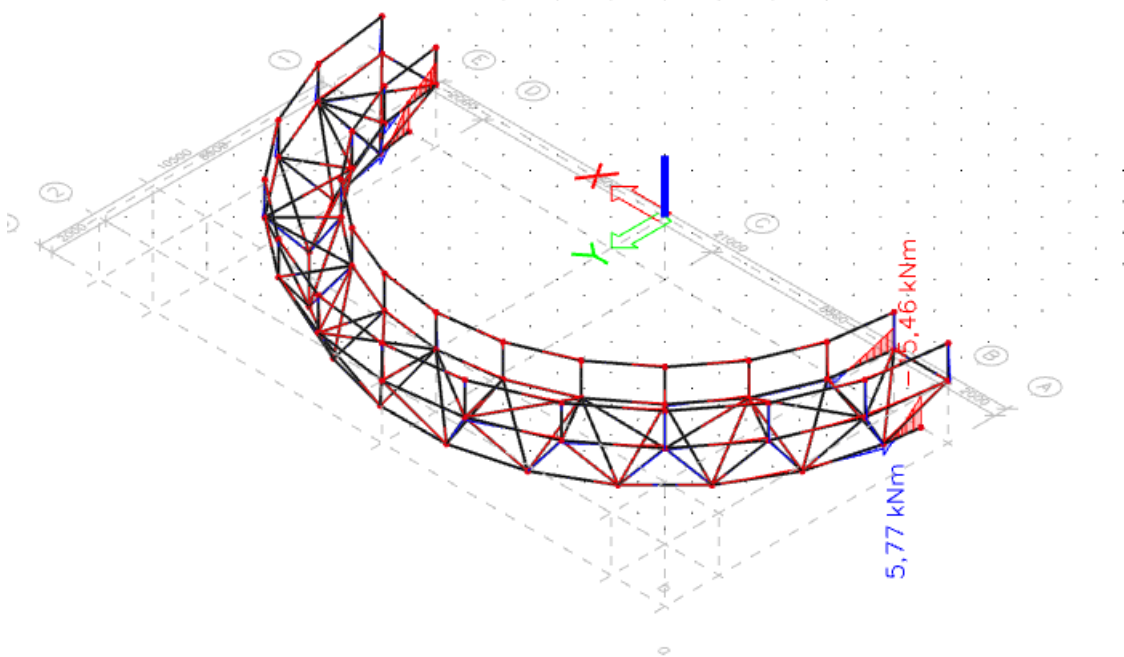

Slika 2.1.5.2. Momentni dijagram opterećenja kombinacije 5 – My (kNm)

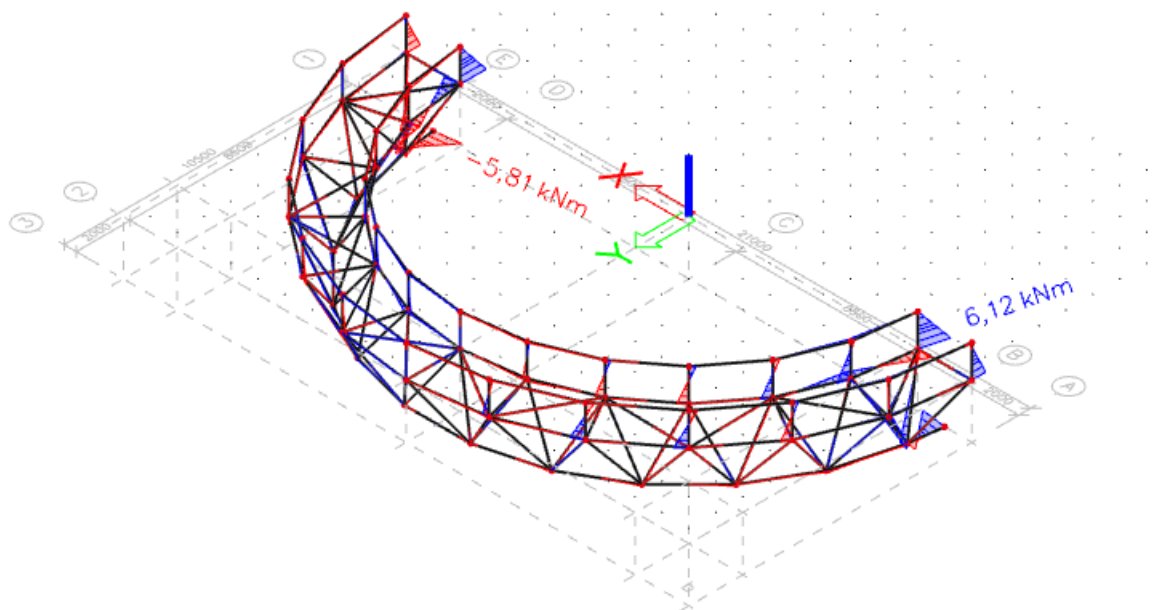
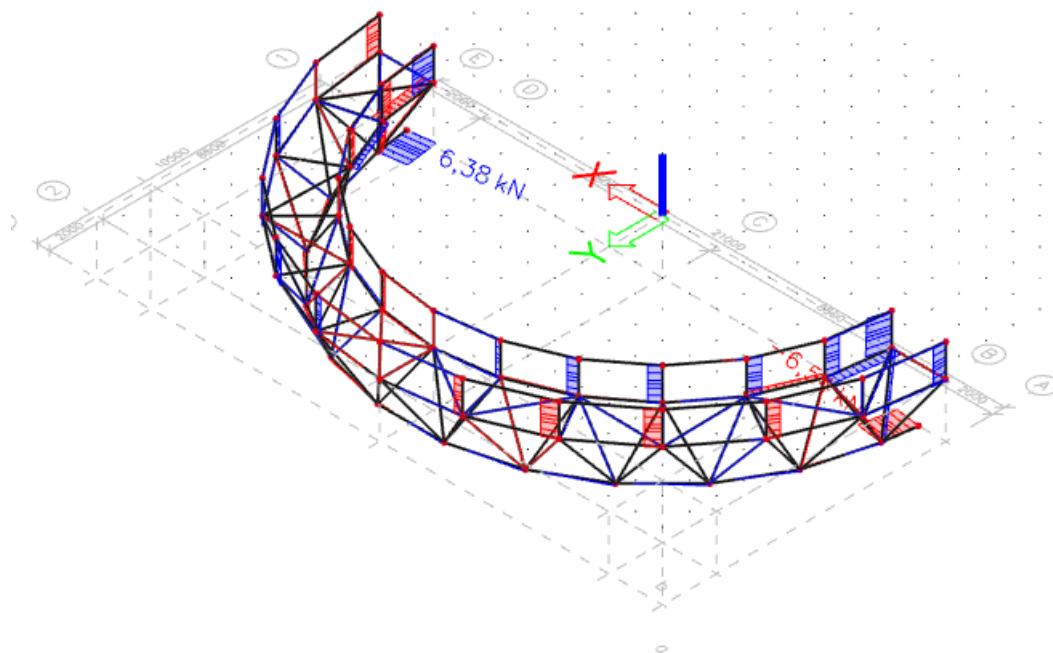
Slika 2.1.5.3. Momentni dijagram opterećenja kombinacije 5 – M_z (kNm)Slika 2.1.5.4. Dijagram poprečnih sila opterećenja kombinacije 5 – V_y (kN)

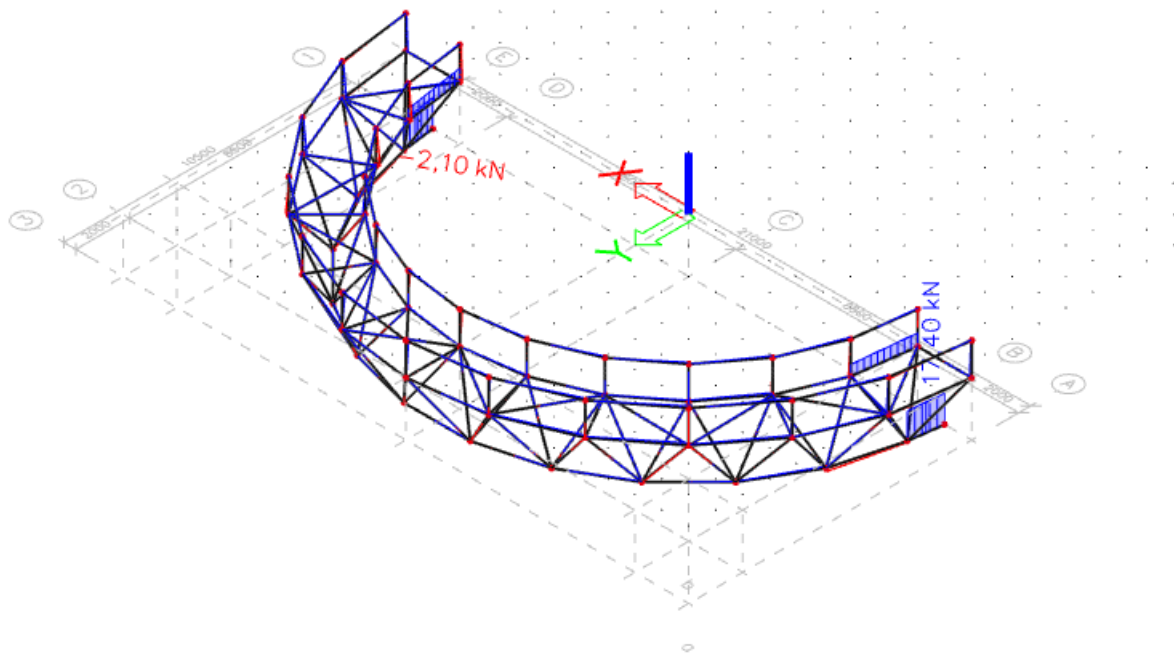
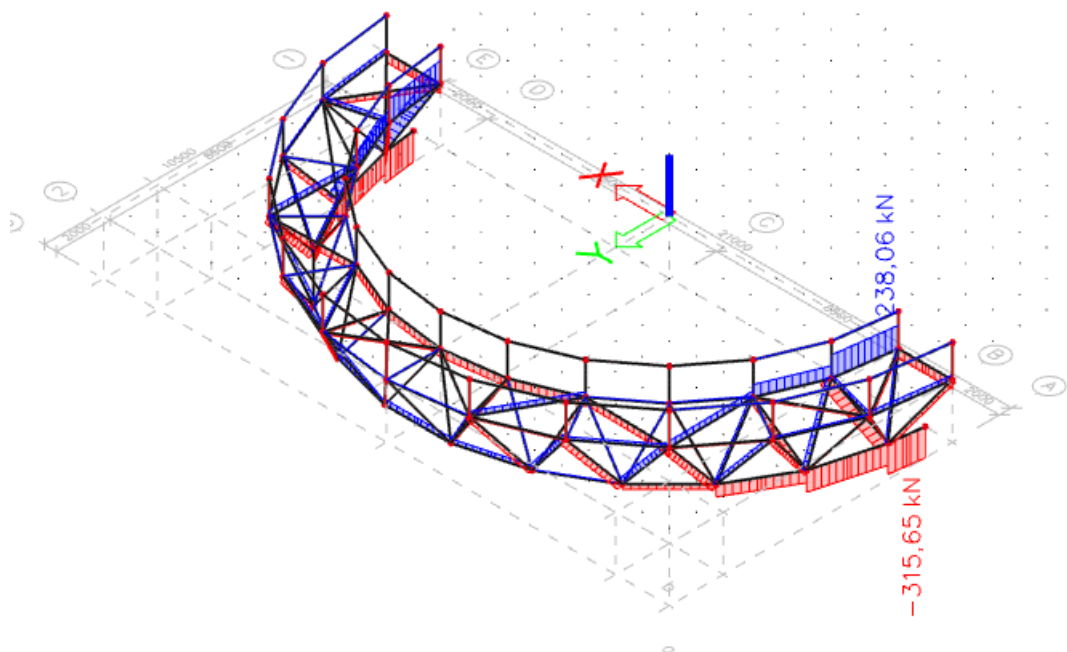
Slika 2.1.5.5. Dijagram poprečnih sila opterećenja kombinacije 5 – V_z (kN)Slika 2.1.5.6. Dijagram uzdužnih sila opterećenja kombinacije 5 – N (kN)

3.1.6. Kombinacija djelovanja 6

$$K_6 = 1,35 \cdot V.T + 0,8 \cdot S + 0,3 \cdot F_w + 1,5 \cdot T_{\min}$$

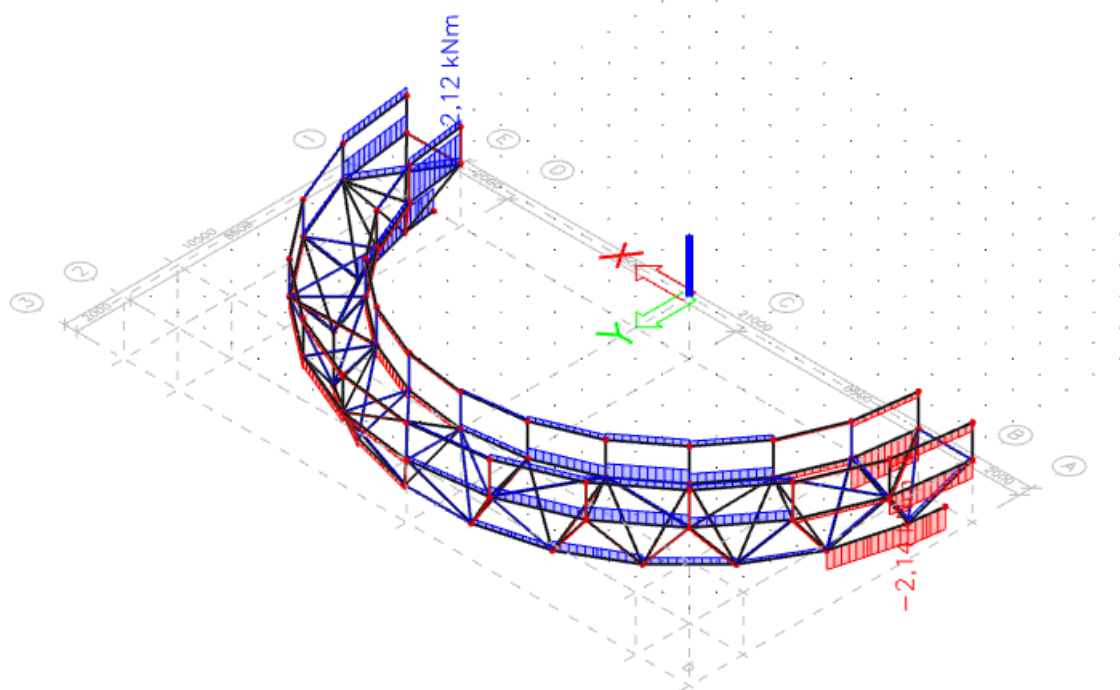

Slika 2.1.6.1. Momentni dijagram opterećenja kombinacije 6 – Mx (kNm)

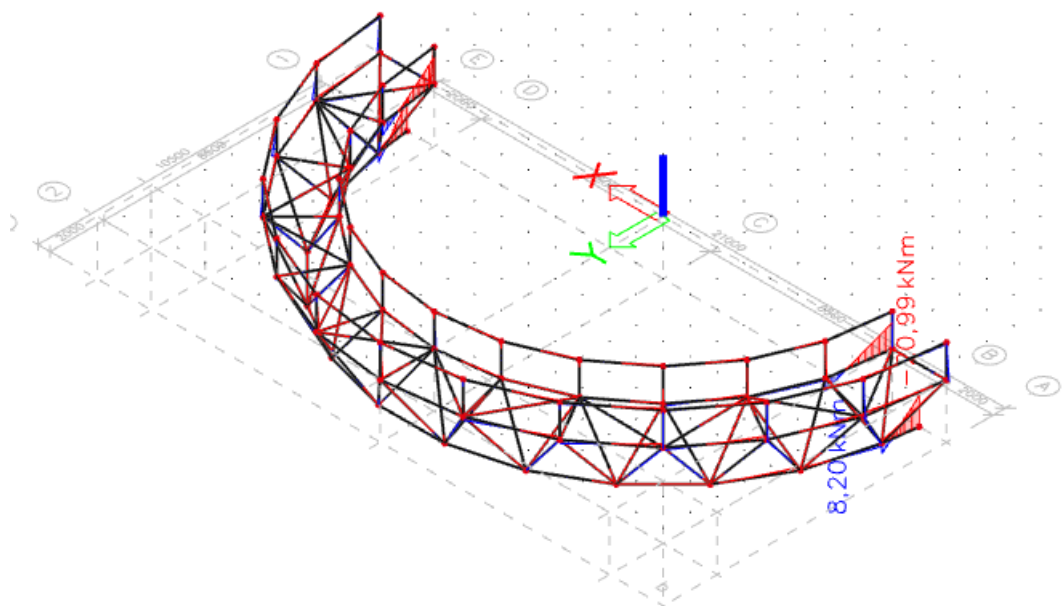

Slika 2.1.6.2. Momentni dijagram opterećenja kombinacije 6 – My (kNm)

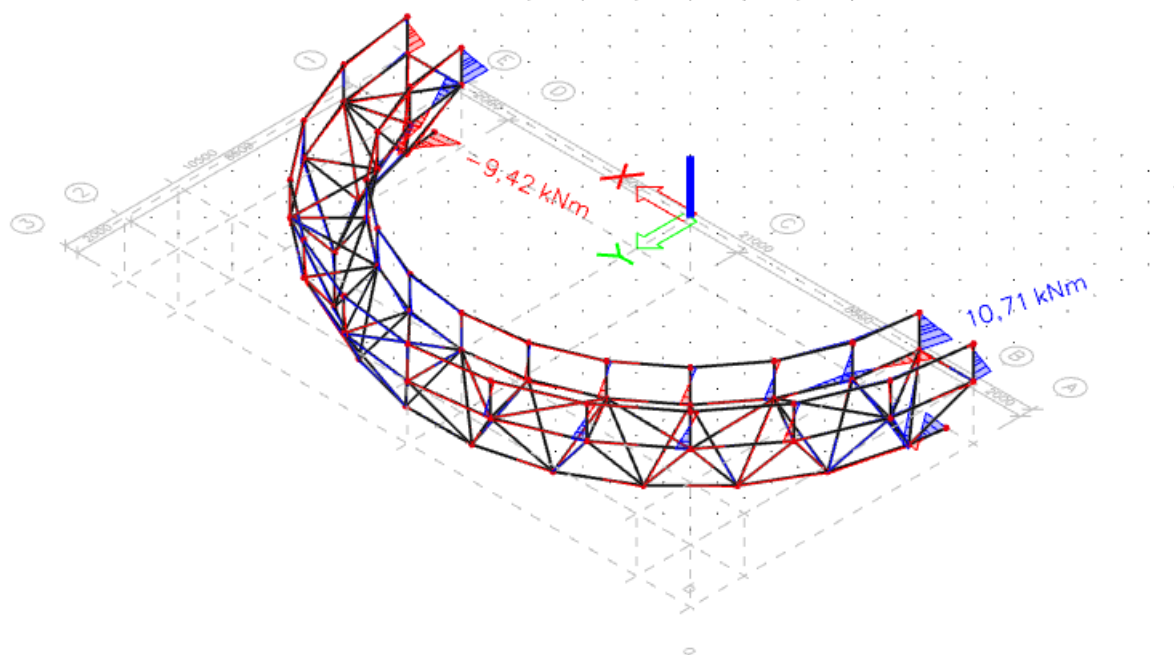
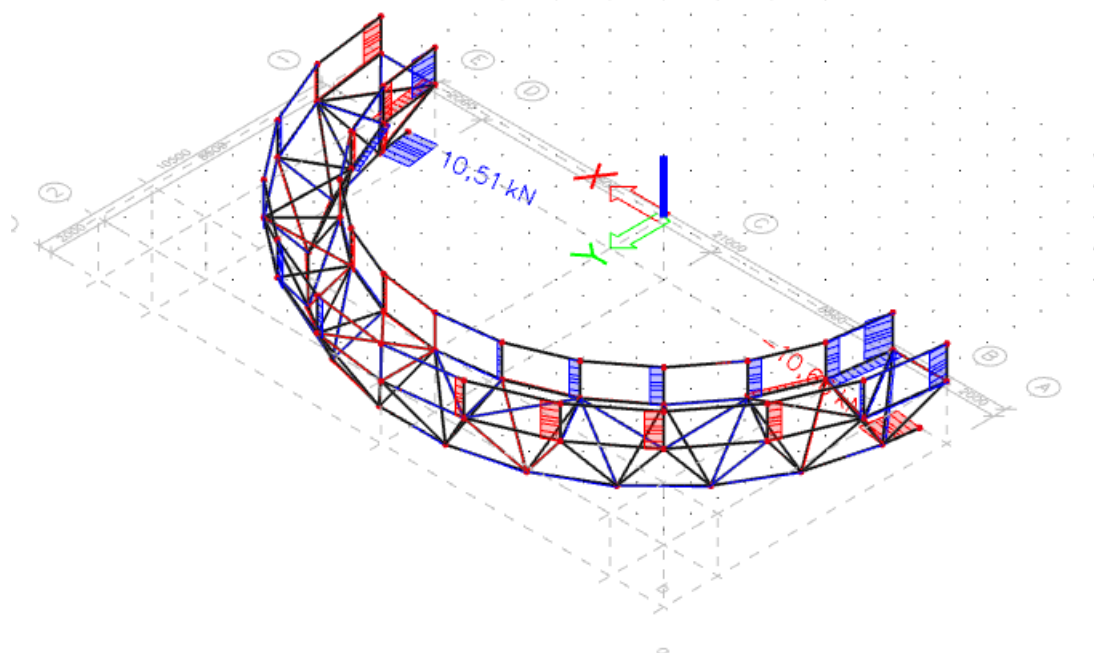
Slika 2.1.6.3. Momentni dijagram opterećenja kombinacije 6 – M_z (kNm)Slika 2.1.6.4. Dijagram poprečnih sila opterećenja kombinacije 6 – V_y (kN)

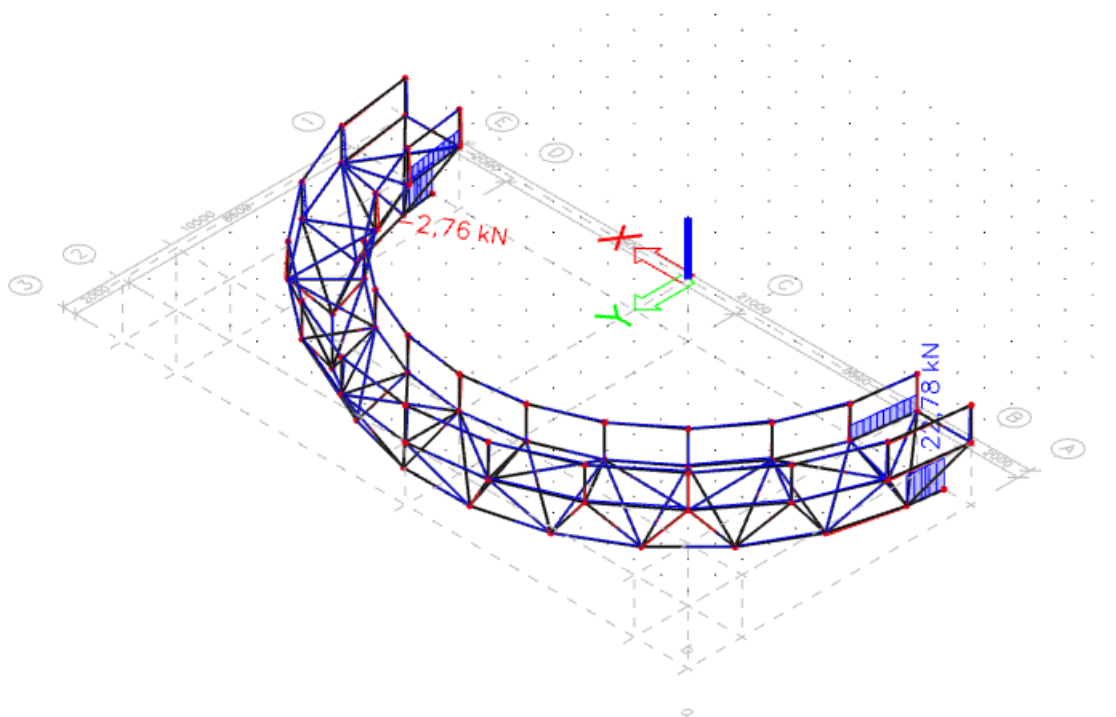

Slika 2.1.6.5. Dijagram poprečnih sila opterećenja kombinacije 6 – Vz (kN)

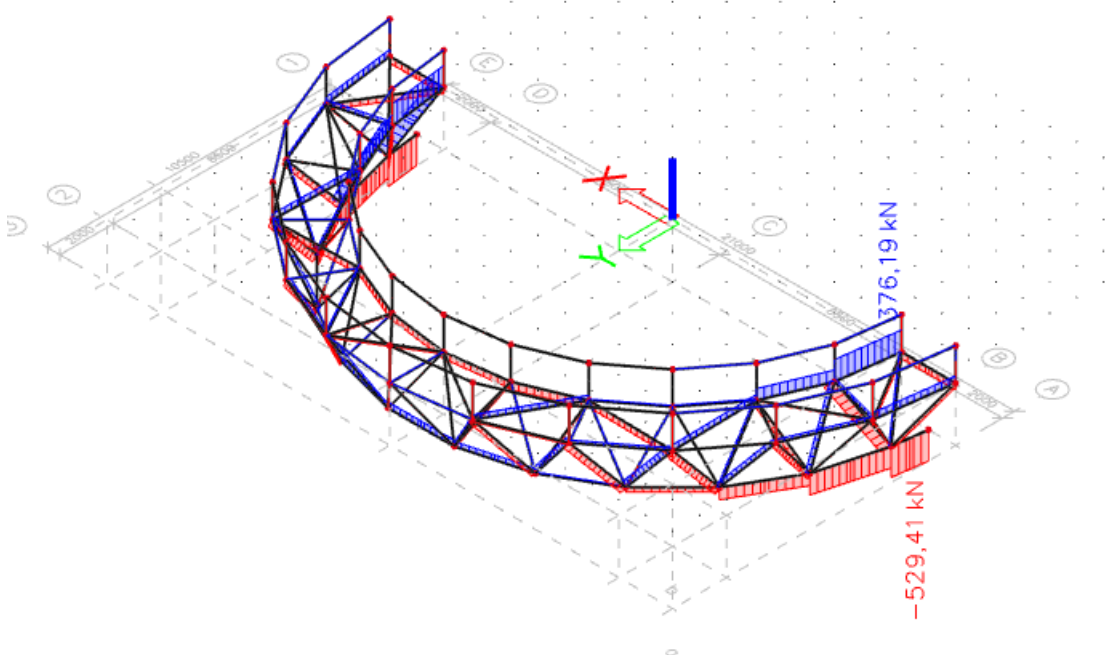

Slika 2.1.6.6. Dijagram uzdužnih sila opterećenja kombinacije 6 – N (kN)

3.2. Dijagrami reznih sila kod četveropojasne rešetke

3.2.1. Kombinacija djelovanja 1

$$K1 = 1,35 \cdot V.T + 1,5 \cdot S + 0,3 \cdot Fw + 0,6 \cdot T_{min}$$

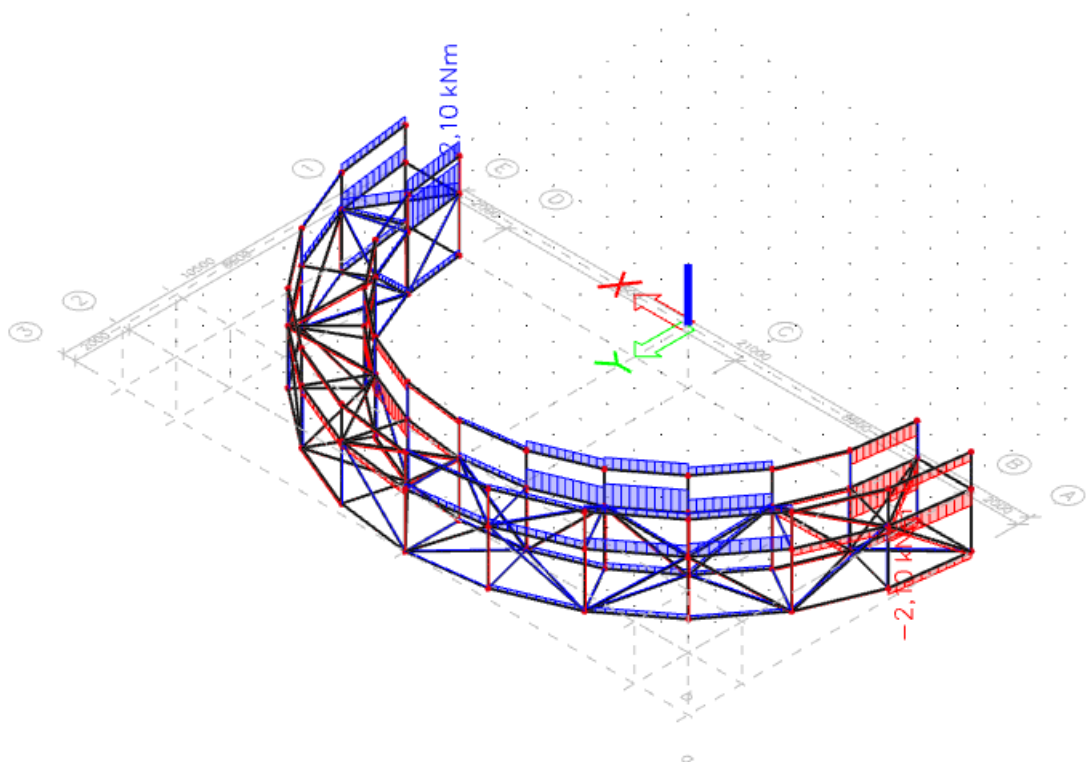

Slika 2.2.1.1. Momentni dijagram opterećenja kombinacije 1 – Mx (kNm)

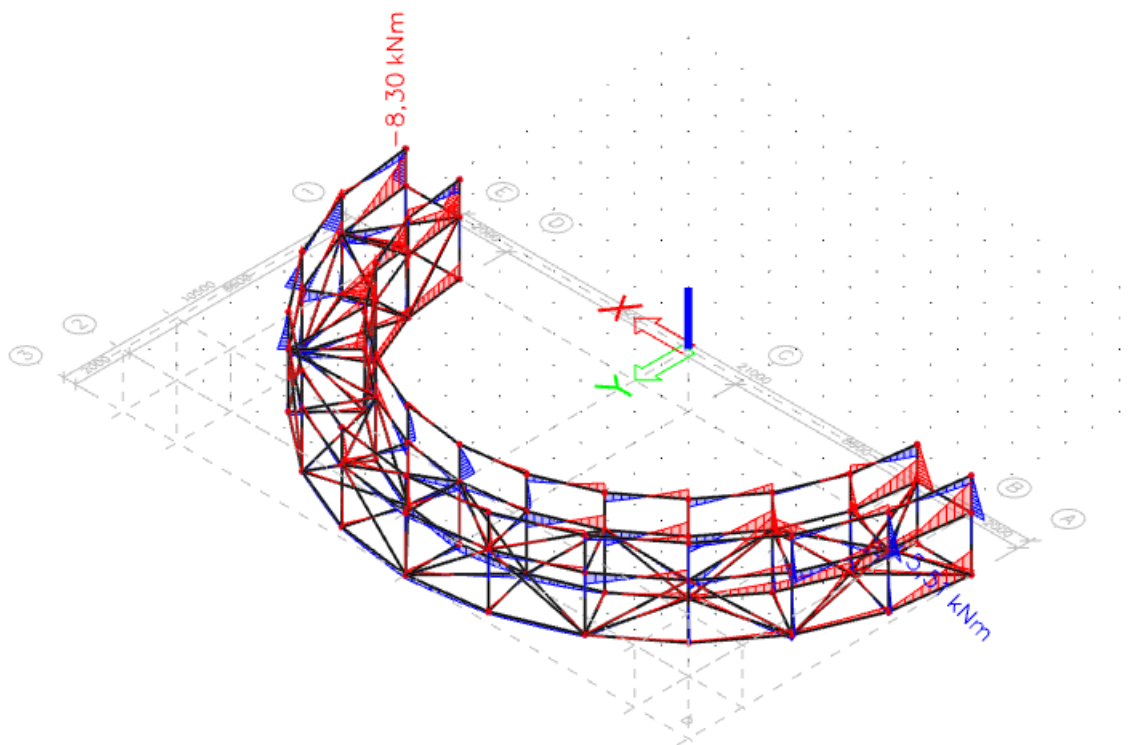

Slika 2.2.1.2. Momentni dijagram opterećenja kombinacije 1 – M_y (kNm)

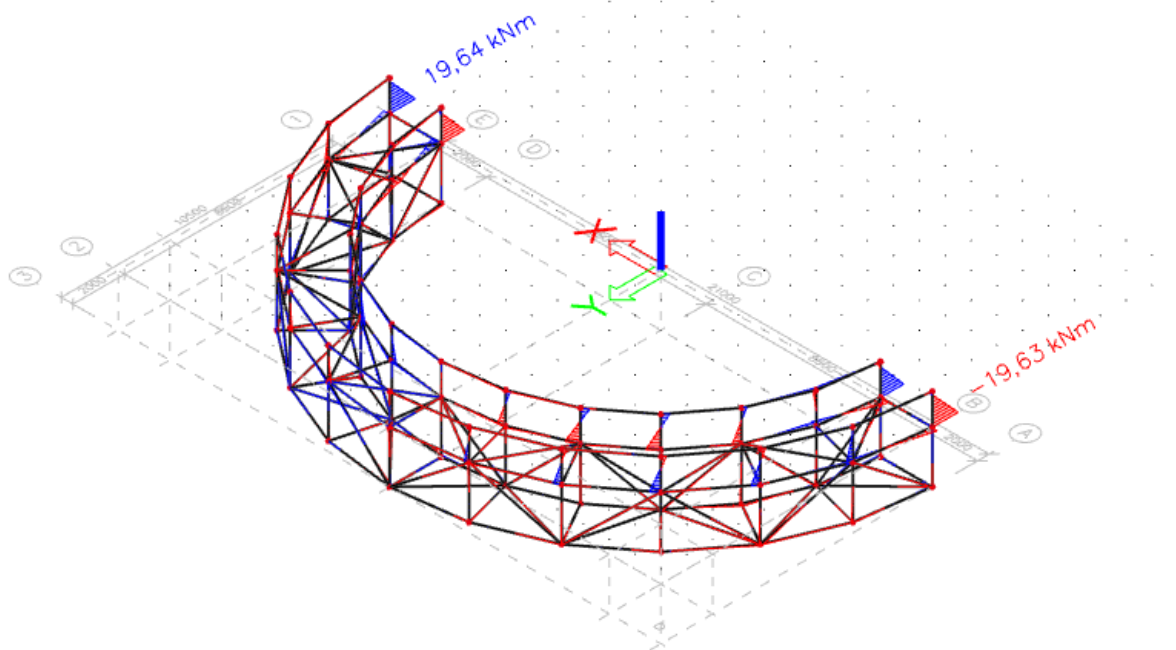

Slika 2.2.1.3. Momentni dijagram opterećenja kombinacije 1 – M_z (kNm)

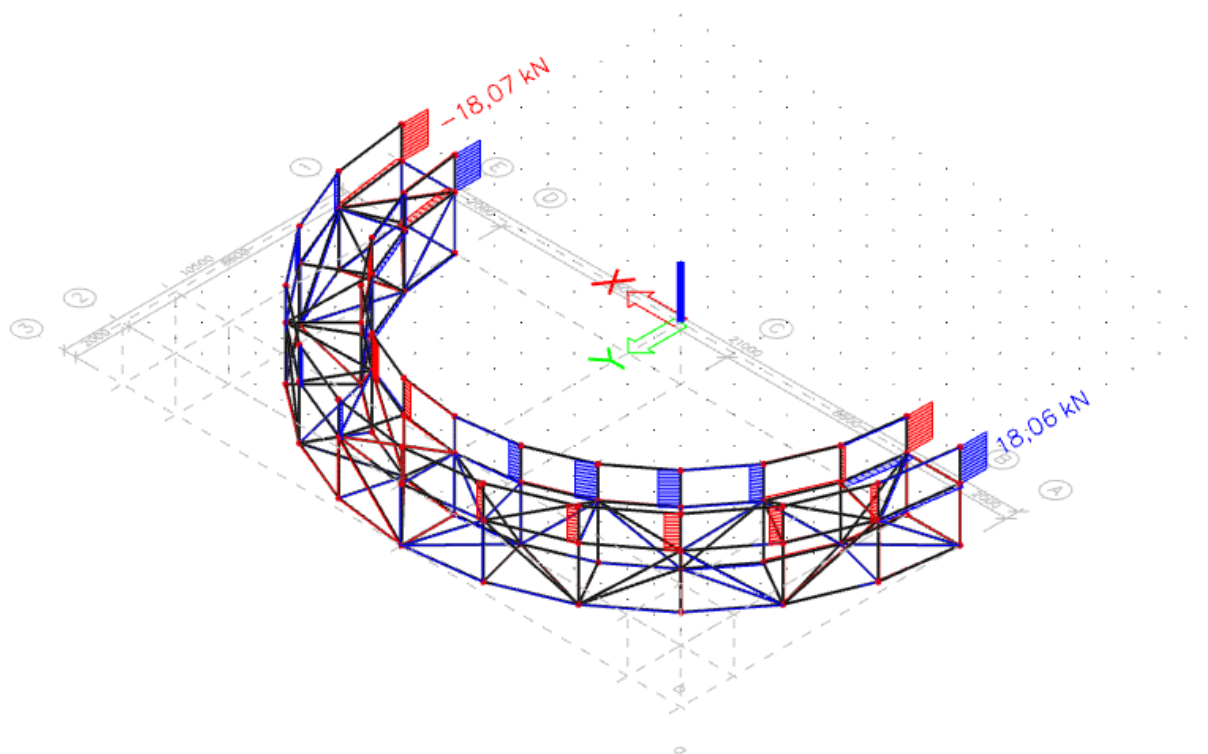
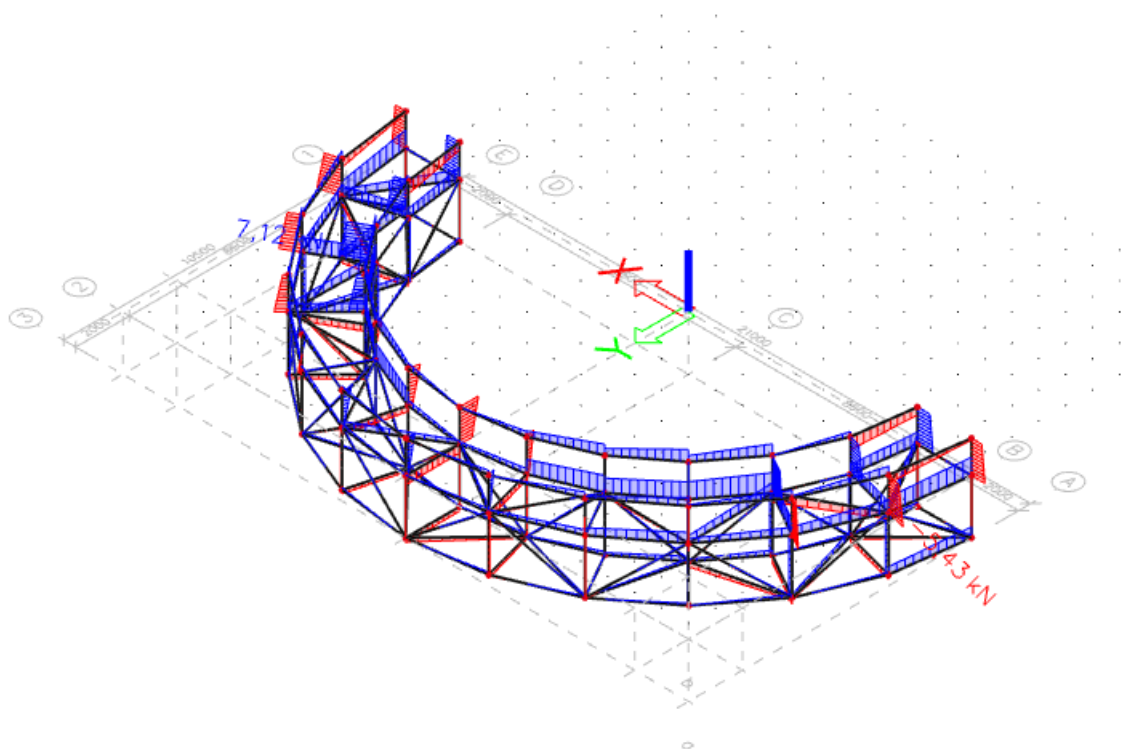
Slika 2.2.1.4. Dijagram poprečnih sila opterećenja kombinacije 1 – V_y (kN)Slika 2.2.1.5. Dijagram poprečnih sila opterećenja kombinacije 1 – V_z (kN)

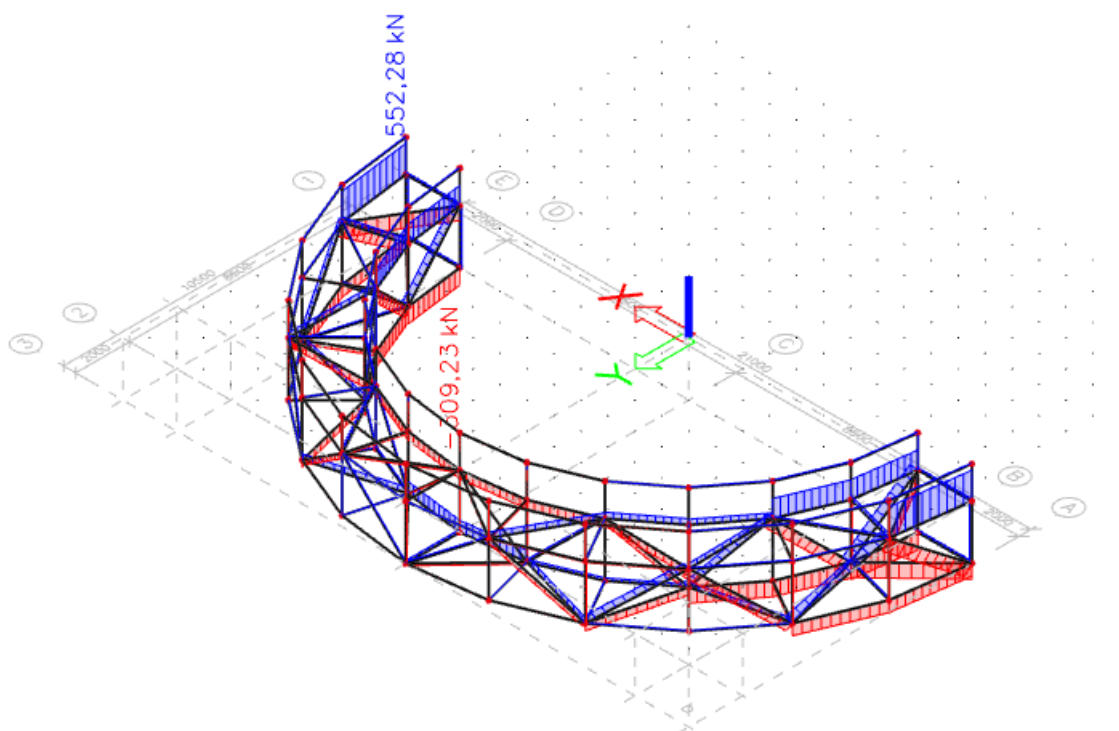

Slika 2.2.1.6. Dijagram uzdužnih sila opterećenja kombinacije 1 – N (kN)

3.2.2. Kombinacija djelovanja 2

$$K2 = 1,35 \cdot V.T + 1,5 \cdot P + 0,3 \cdot Fw + 0,6 \cdot Tmax$$

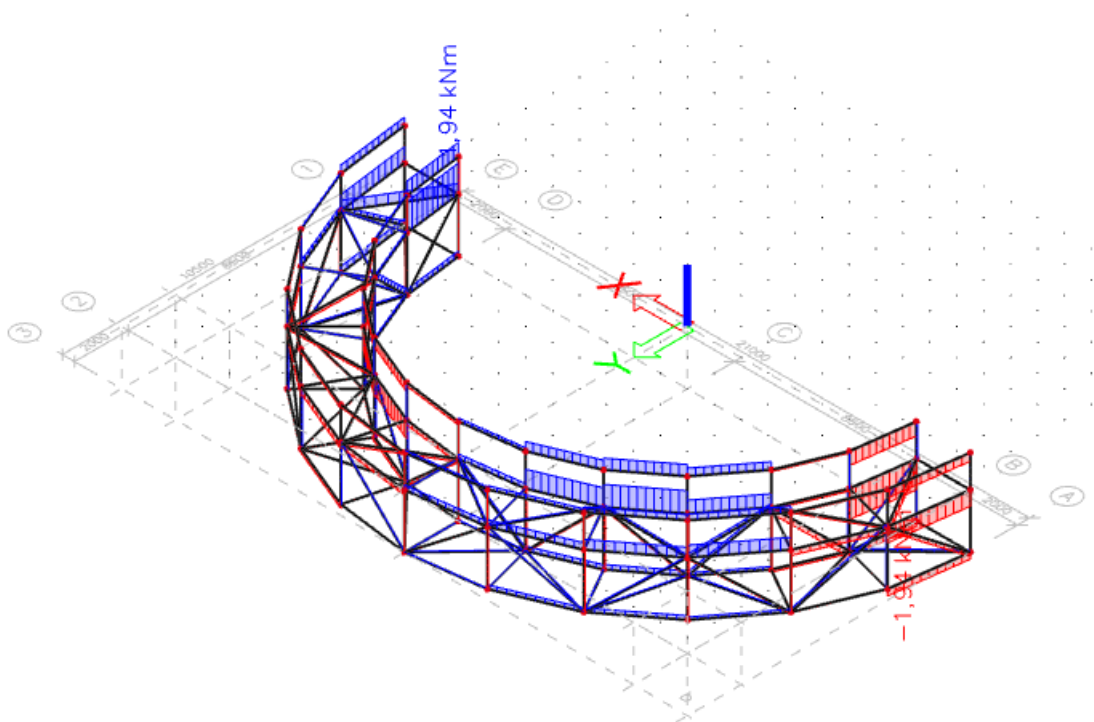

Slika 2.2.2.1. Momentni dijagram opterećenja kombinacije 2 – Mx (kNm)

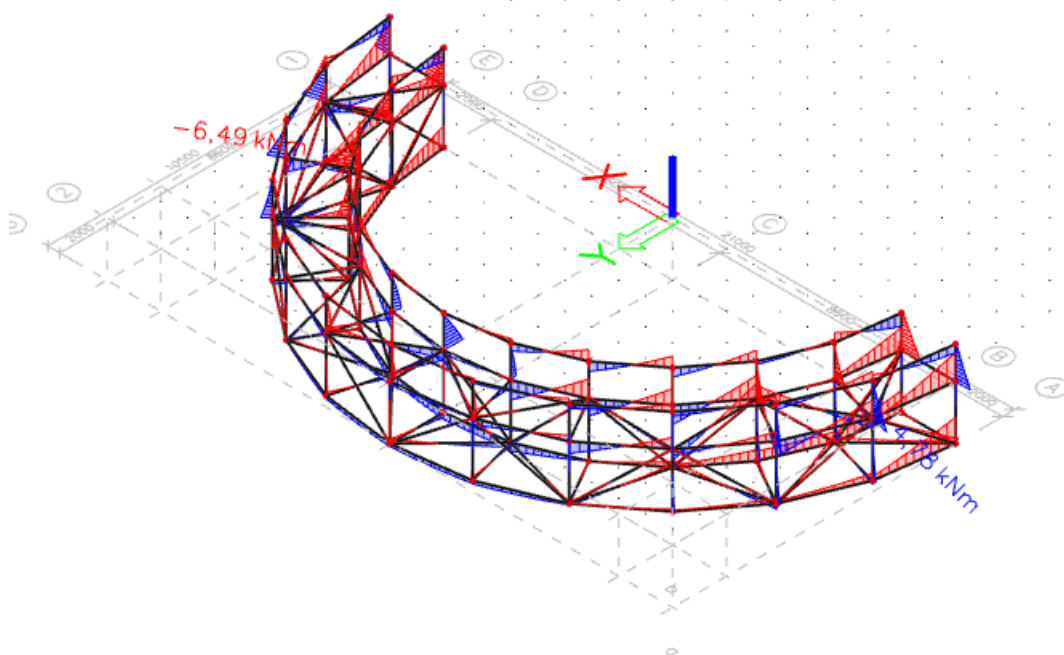

Slika 2.2.2.2. Momentni dijagram opterećenja kombinacije 2 – My (kNm)

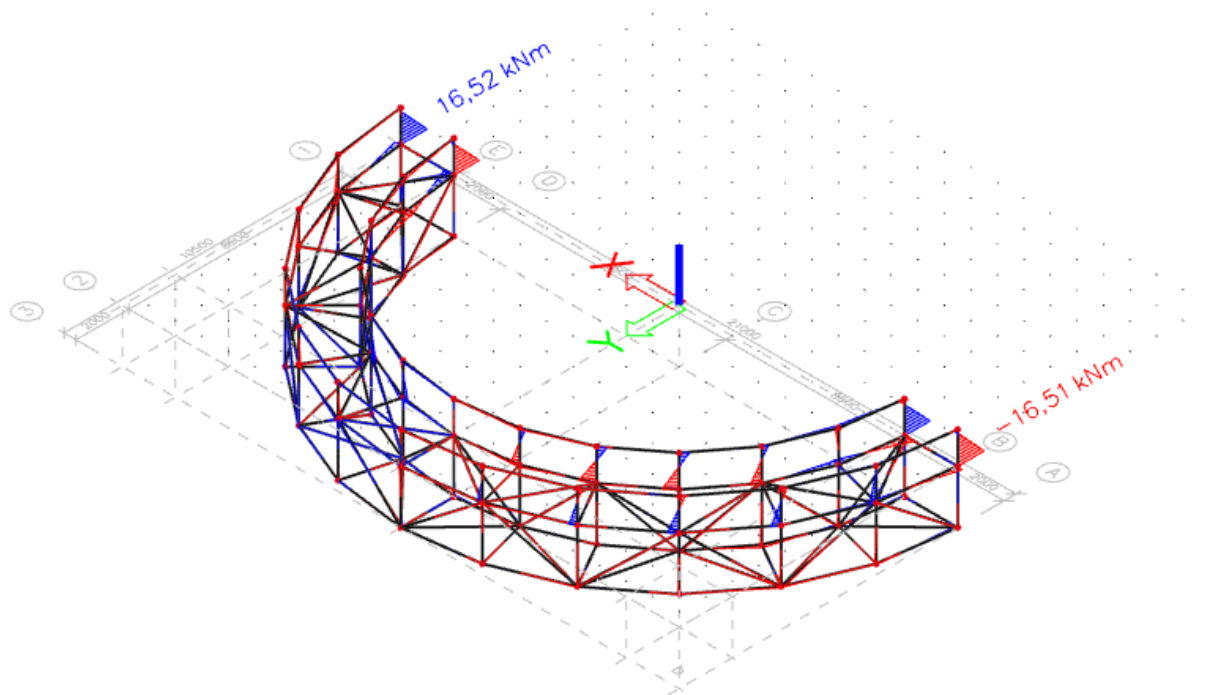

Slika 2.2.2.3. Momentni dijagram opterećenja kombinacije 2 – M_z (kNm)

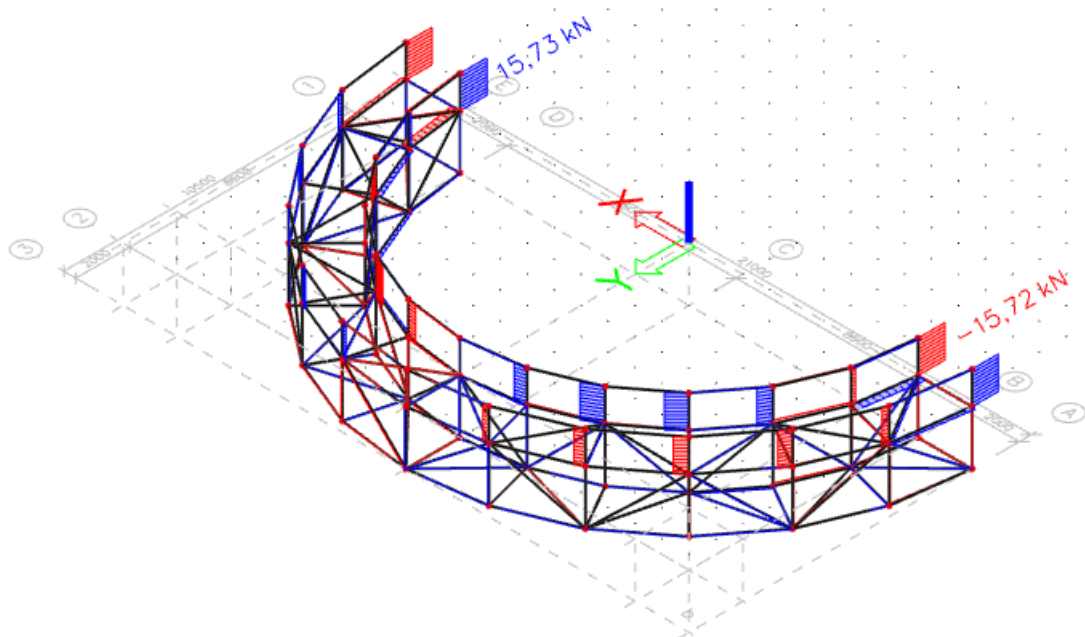

Slika 2.2.2.4. Dijagram poprečnih sila opterećenja kombinacije 2 – V_y (kN)

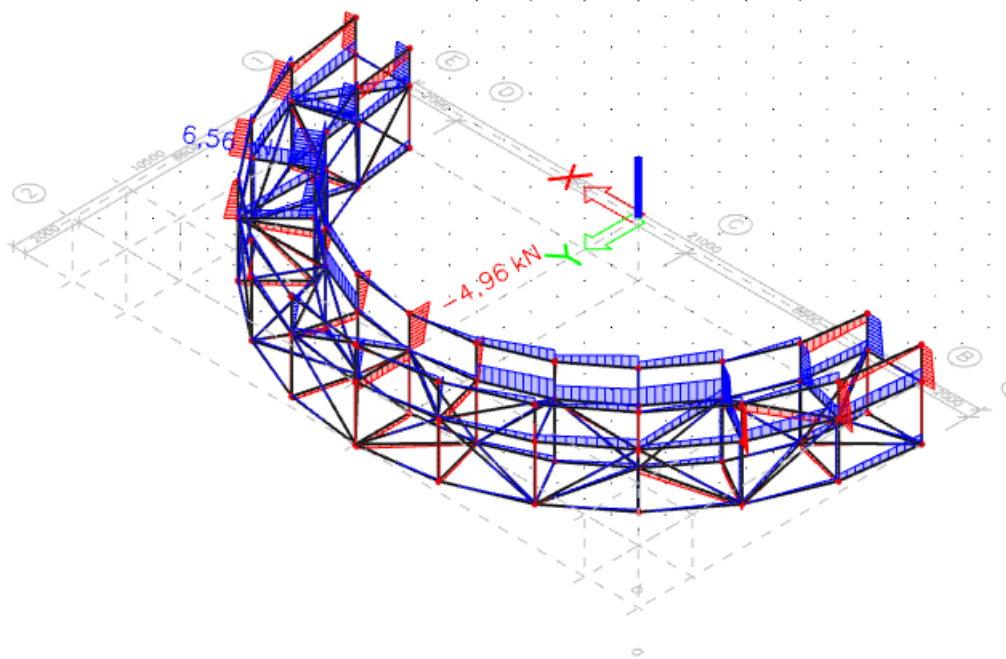

Slika 2.2.2.5. Dijagram poprečnih sila opterećenja kombinacije 2 – Vz (kN)

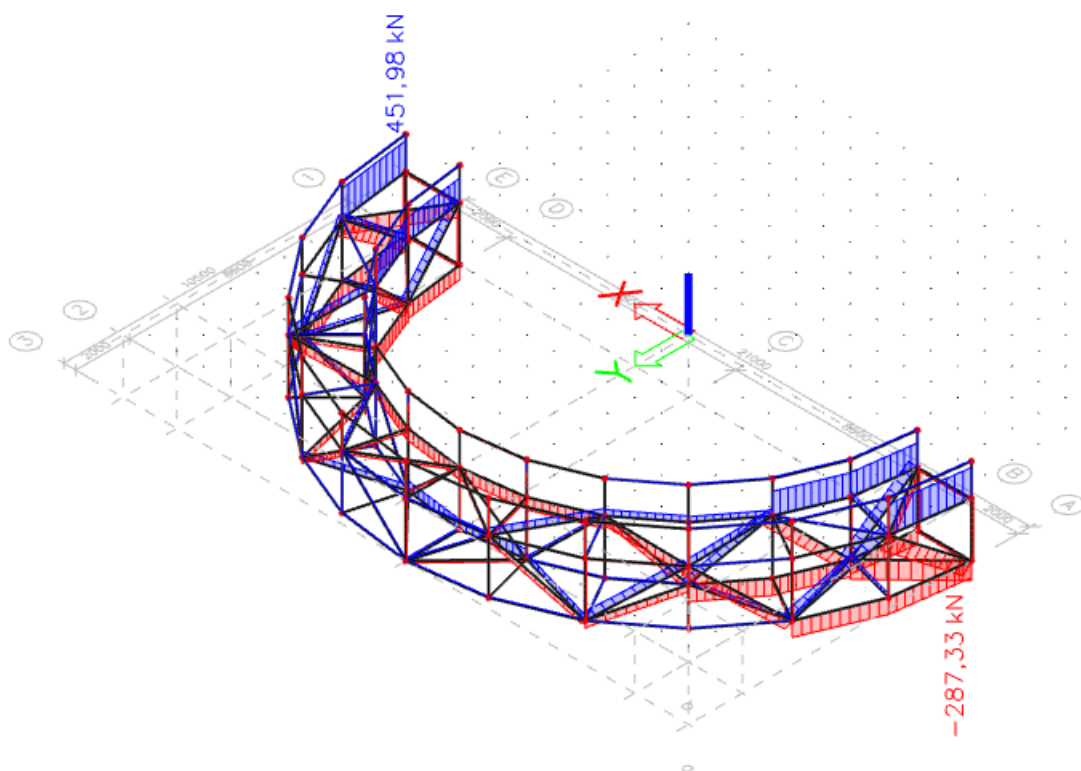

Slika 2.2.2.6. Dijagram uzdužnih sila opterećenja kombinacije 2 – N (kN)

3.2.3. Kombinacija djelovanja 3

$$K3 = 1,35 \cdot V.T + 0,8 \cdot S + 1,5 \cdot F_w + 0,6 \cdot T_{min}$$

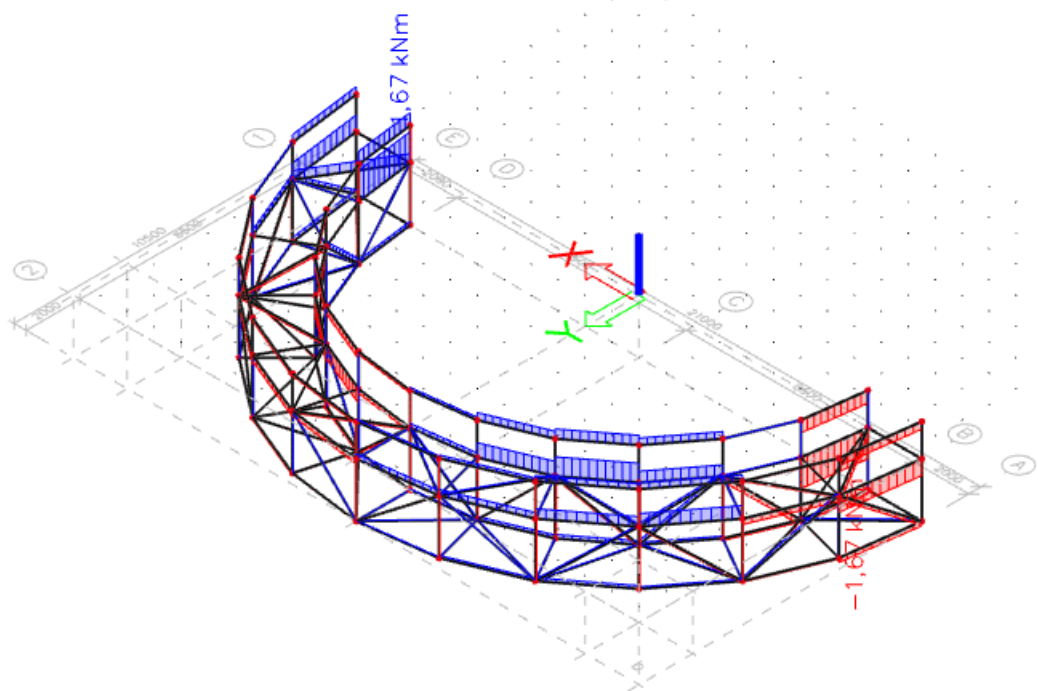

Slika 2.2.3.1. Momentni dijagram opterećenja kombinacije 3 – Mx (kNm)

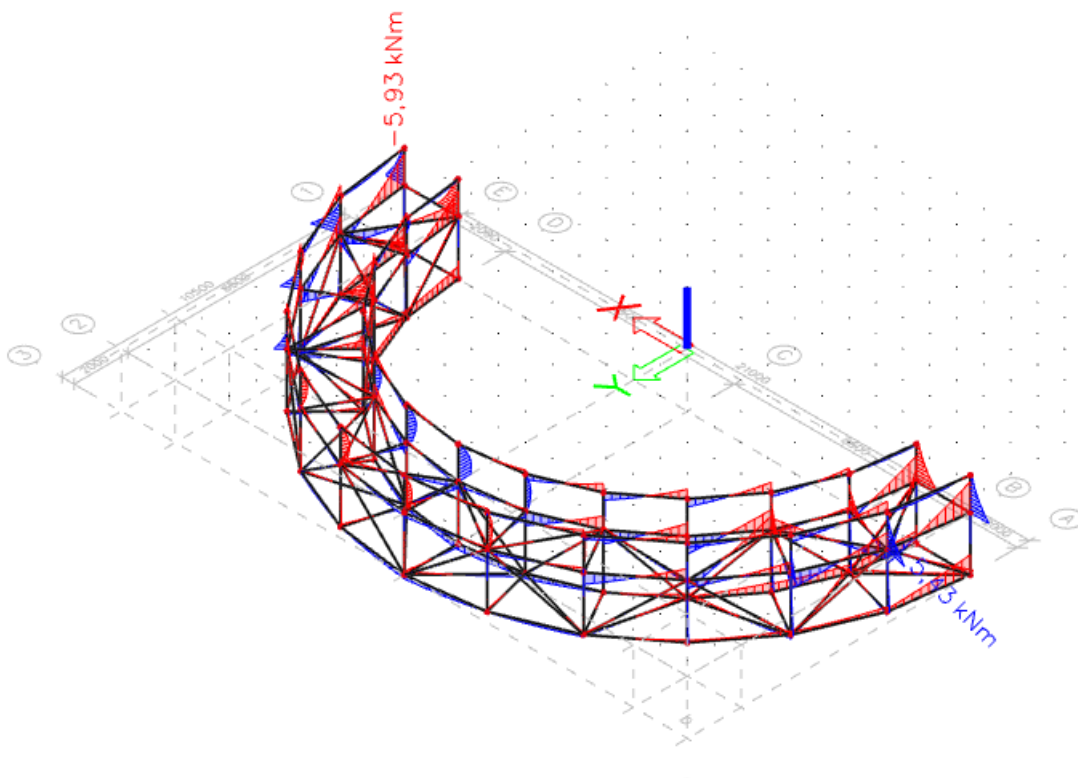

Slika 2.2.3.2. Momentni dijagram opterećenja kombinacije 3 – My (kNm)

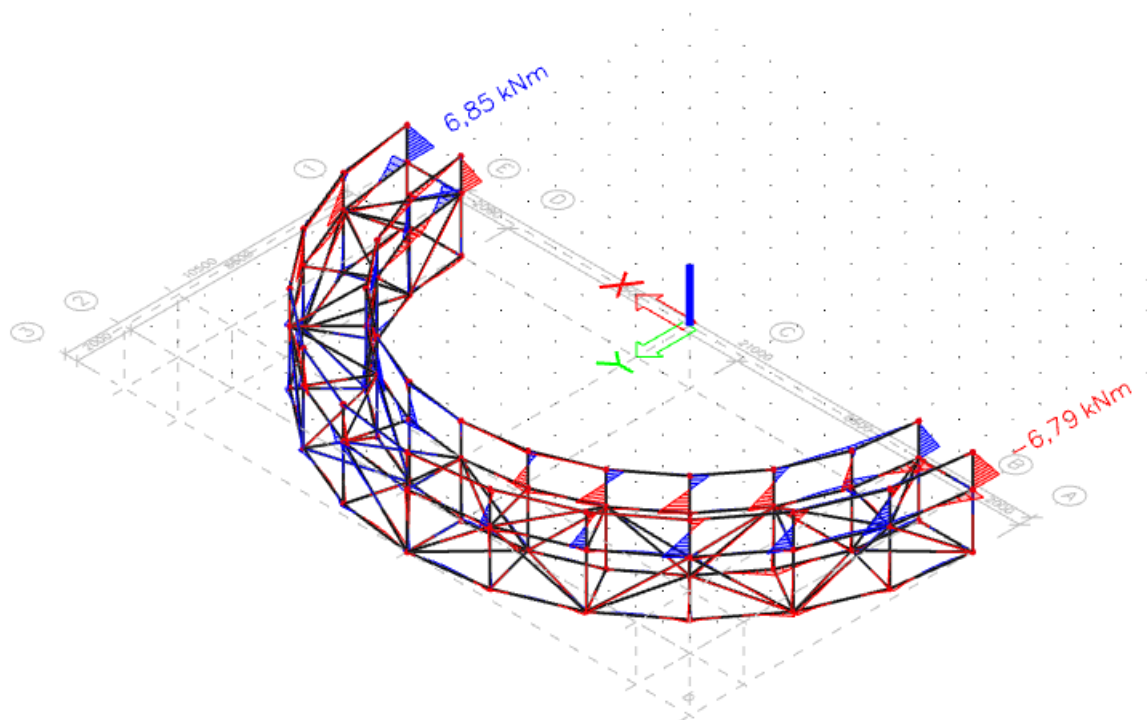

Slika 2.2.3.3. Momentni dijagram opterećenja kombinacije 3 – M_z (kNm)

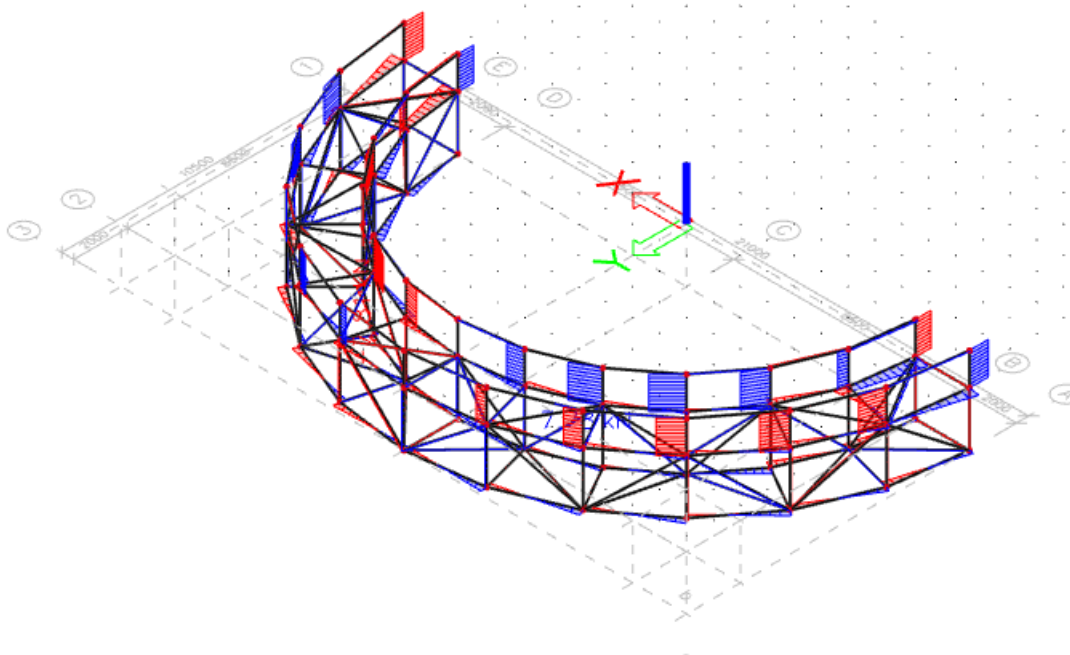

Slika 2.2.3.4. Dijagram poprečnih sila opterećenja kombinacije 3 – V_y (kN)

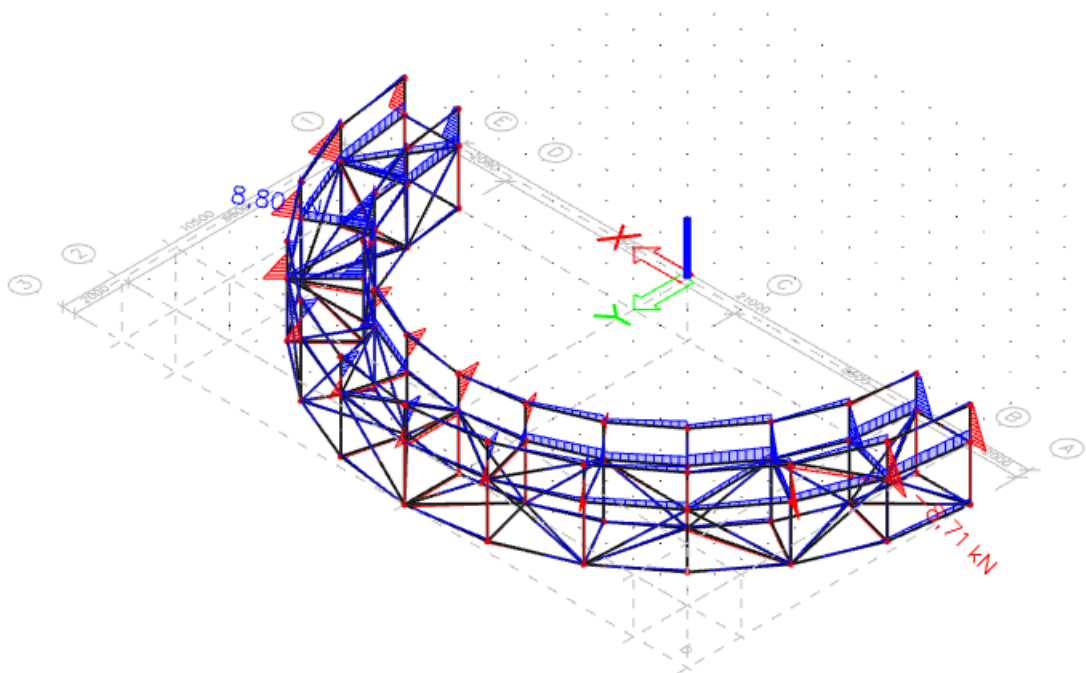

Slika 2.2.3.5. Dijagram poprečnih sila opterećenja kombinacije 3 – Vz (kN)

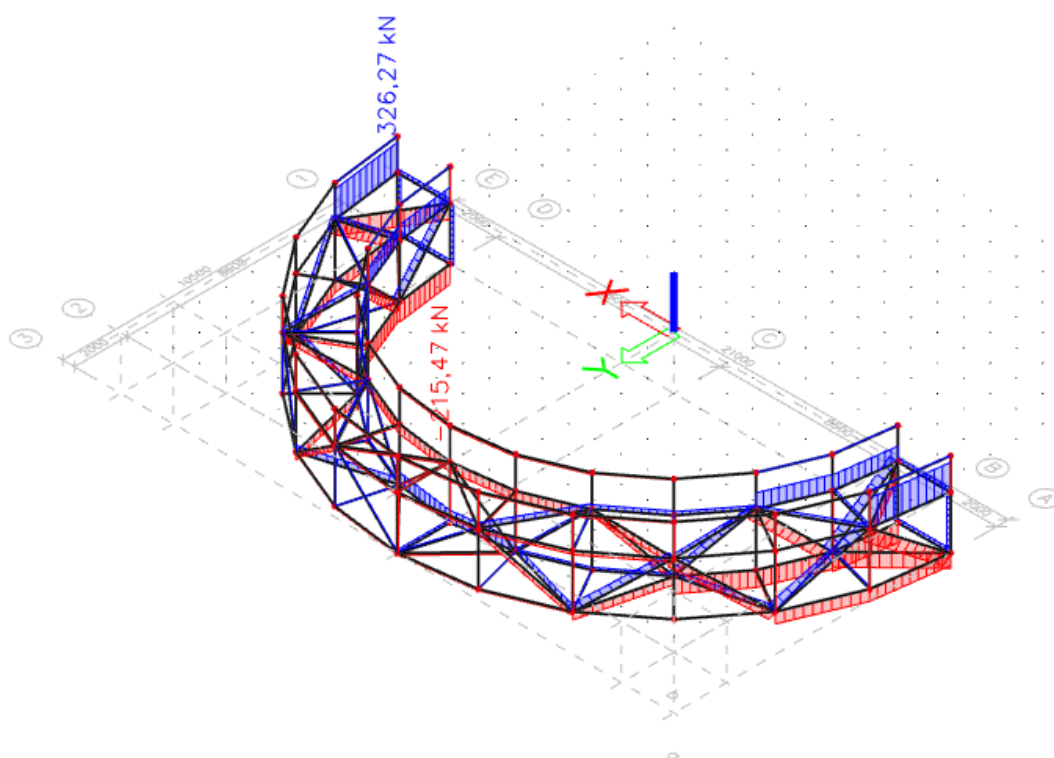

Slika 2.2.3.6. Dijagram uzdužnih sila opterećenja kombinacije 3 – N (kN)

3.2.4. Kombinacija djelovanja 4

$$K_4 = 1,35 \cdot V.T + 0,4 \cdot P + 1,5 \cdot F_w + 0,6 \cdot T_{\max}$$

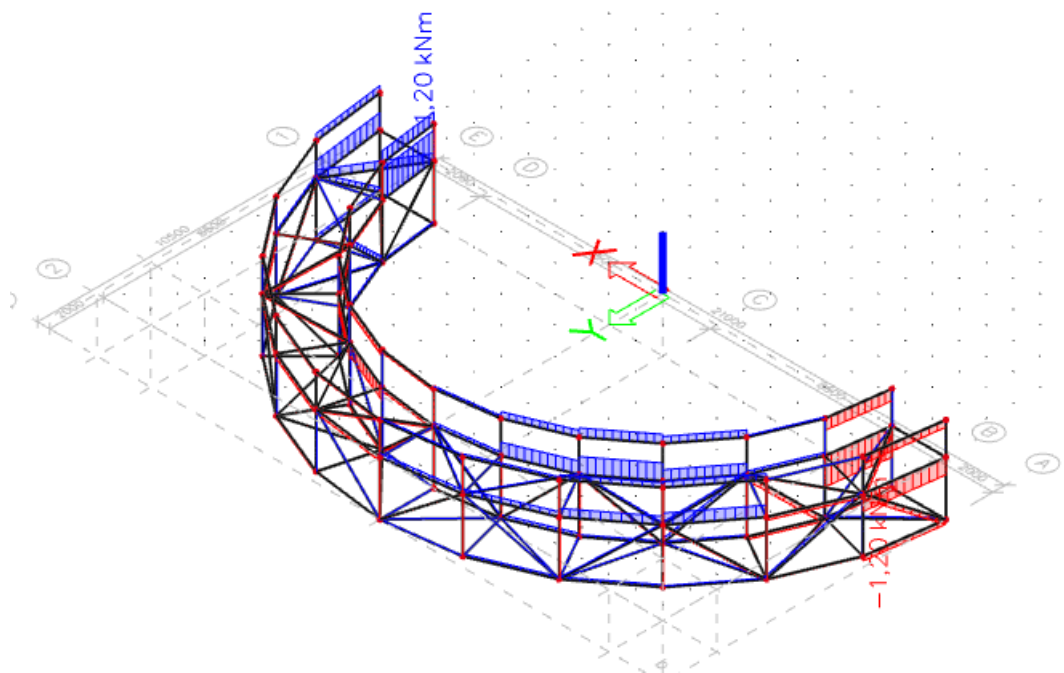

Slika 2.2.4.1. Momentni dijagram opterećenja kombinacije 4 – Mx (kNm)

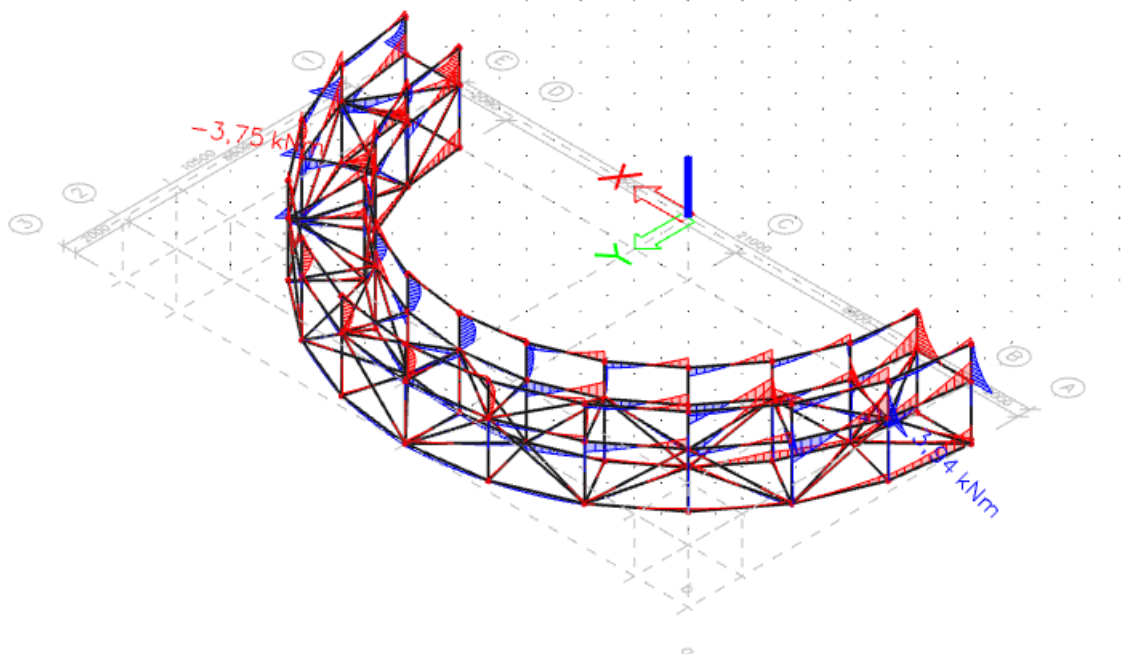

Slika 2.2.4.2. Momentni dijagram opterećenja kombinacije 4 – My (kNm)

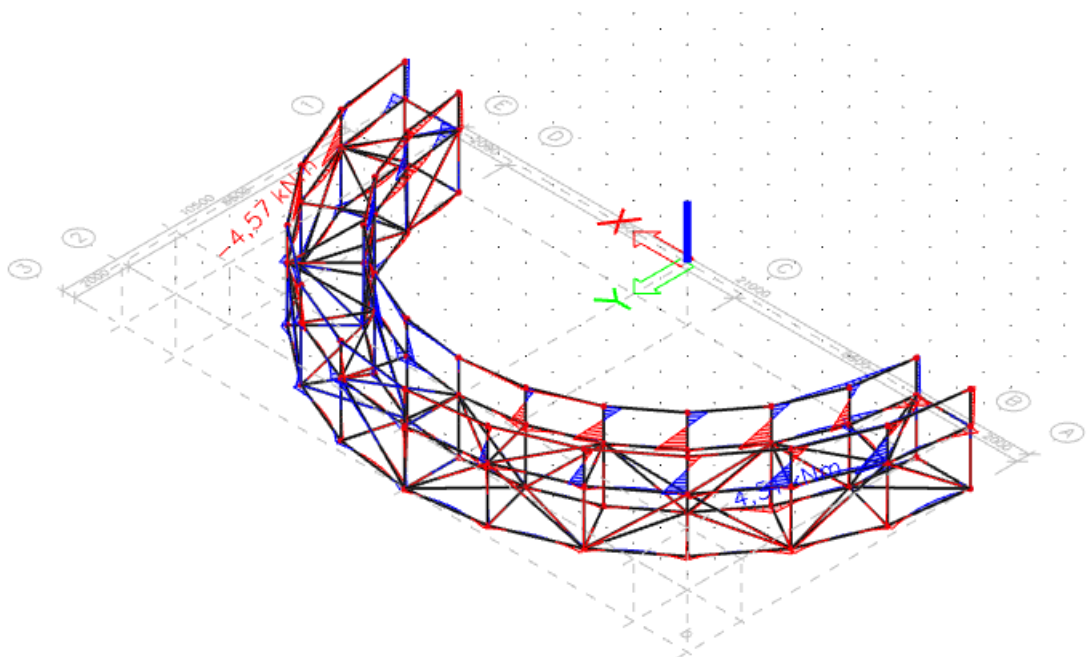

Slika 2.2.4.3. Momentni dijagram opterećenja kombinacije 4 – M_z (kNm)

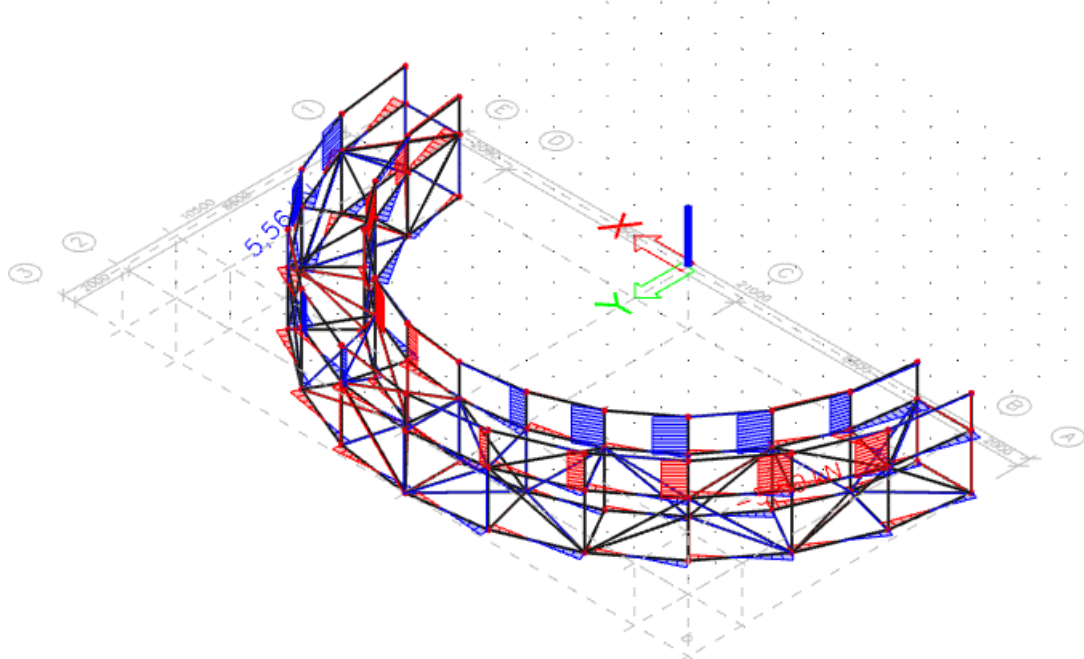

Slika 2.2.4.4. Dijagram poprečnih sila opterećenja kombinacije 4 – V_y (kN)

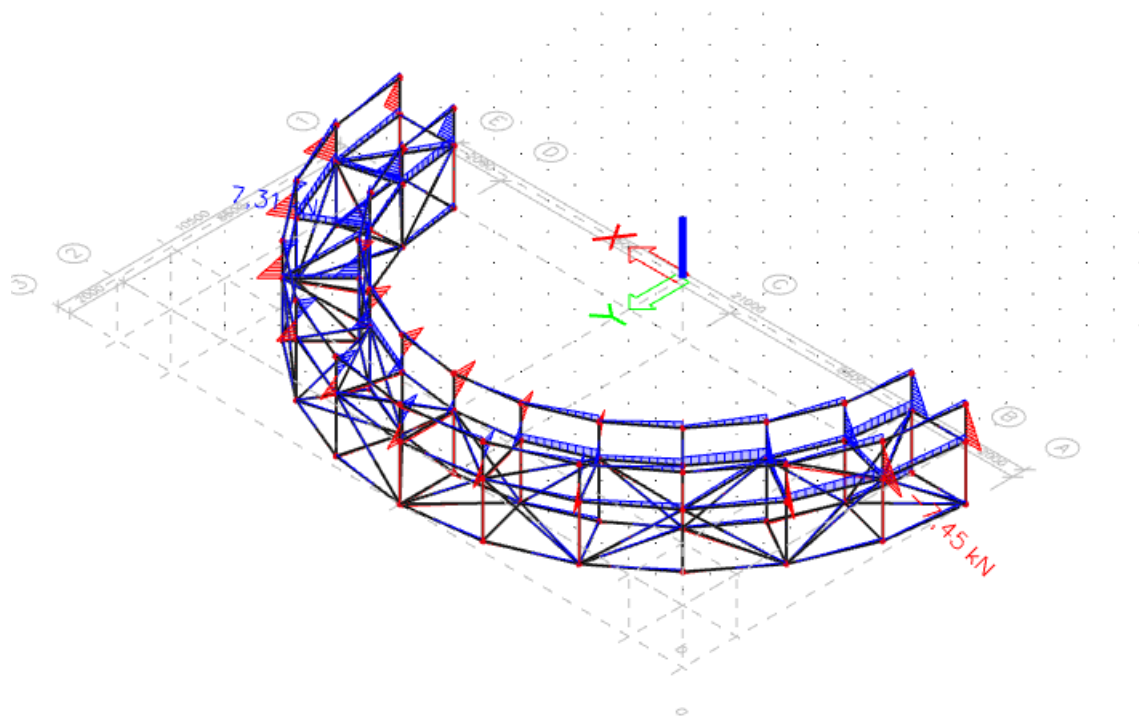
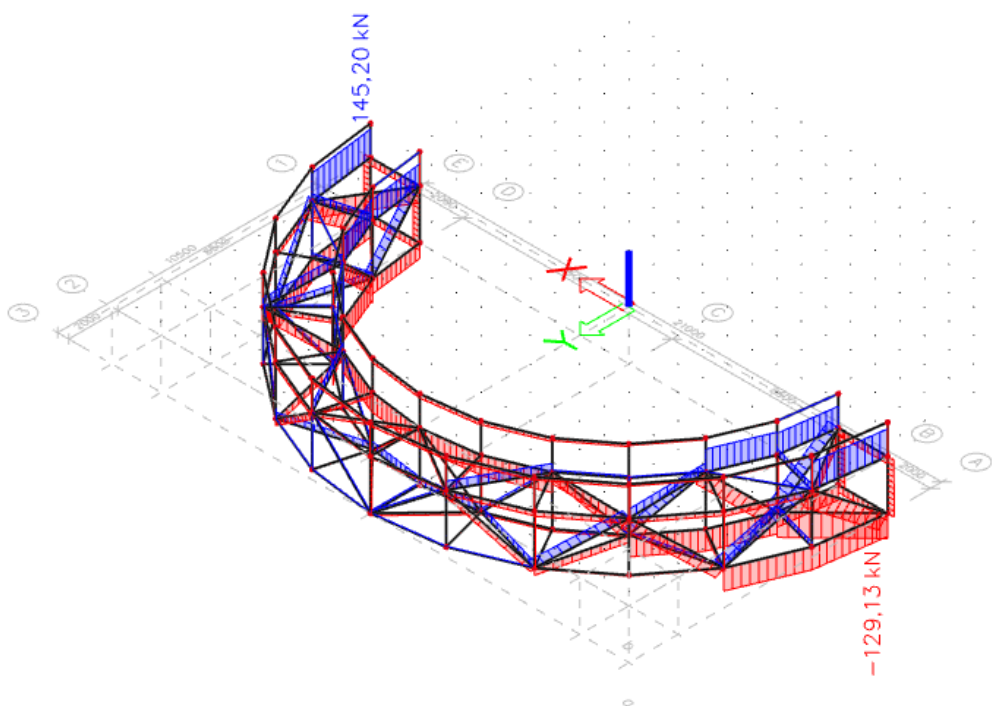
Slika 2.2.4.5. Dijagram poprečnih sila opterećenja kombinacije 4 – V_z (kN)Slika 2.2.4.6. Dijagram uzdužnih sila opterećenja kombinacije 4 – N (kN)

3.2.5. Kombinacija djelovanja 5

$$K_5 = 1,35 \cdot V.T + 0,4 \cdot P + 0,3 \cdot F_w + 1,5 \cdot T_{\max}$$

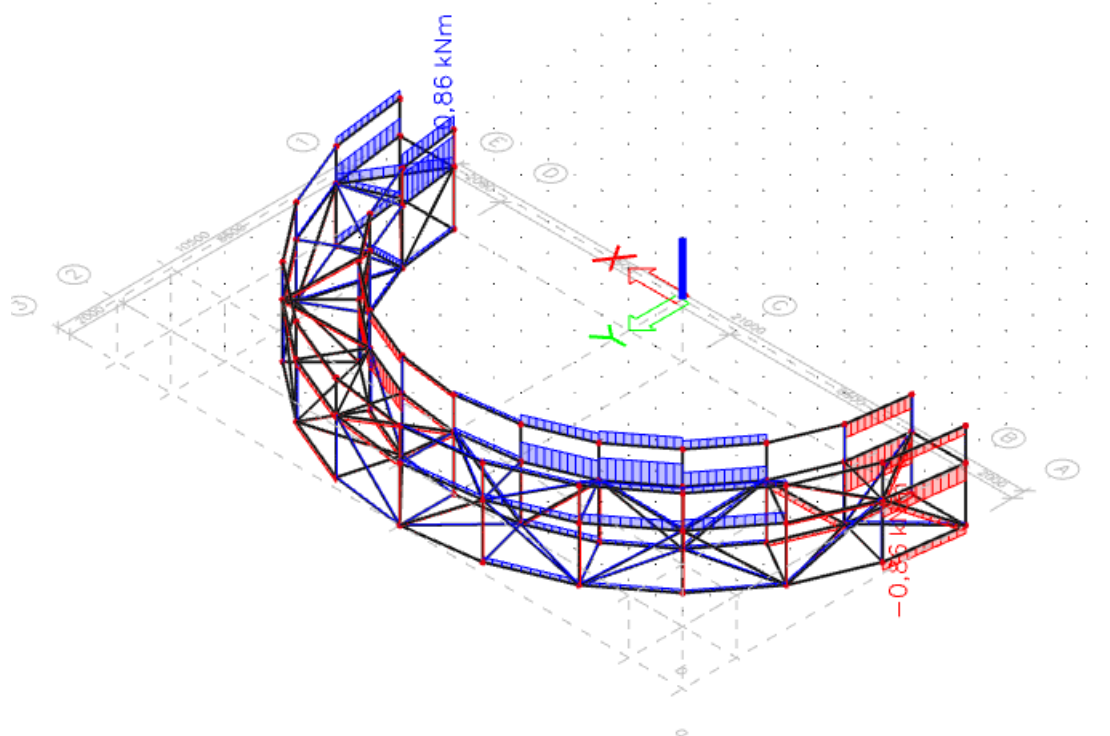

Slika 2.2.5.1. Momentni dijagram opterećenja kombinacije 5 – Mx (kNm)

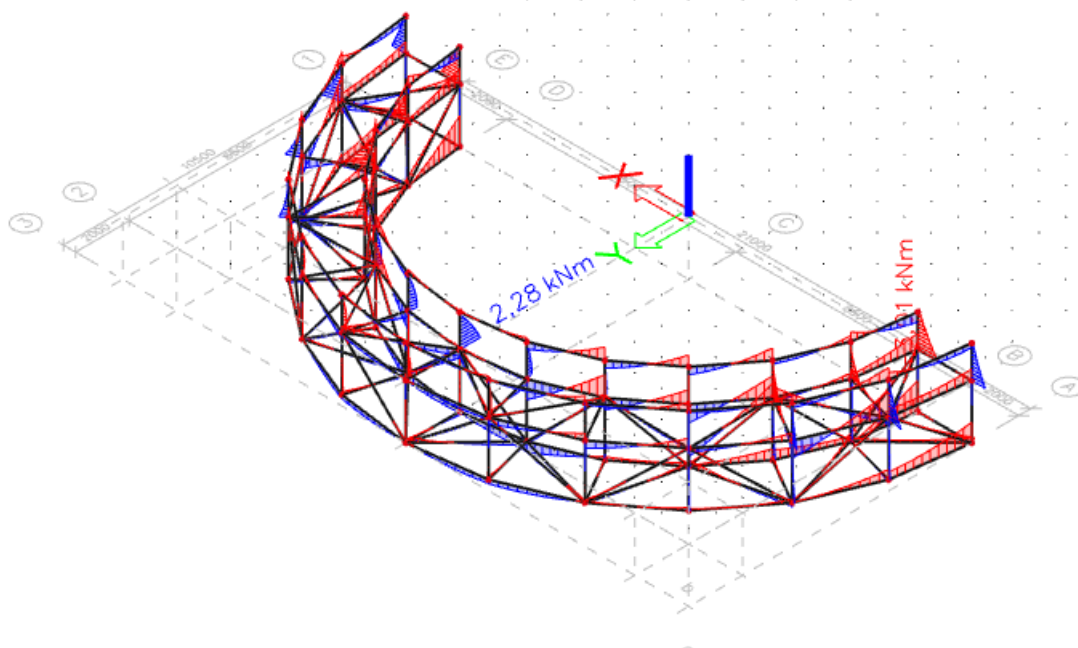

Slika 2.2.5.2. Momentni dijagram opterećenja kombinacije 5 – My (kNm)

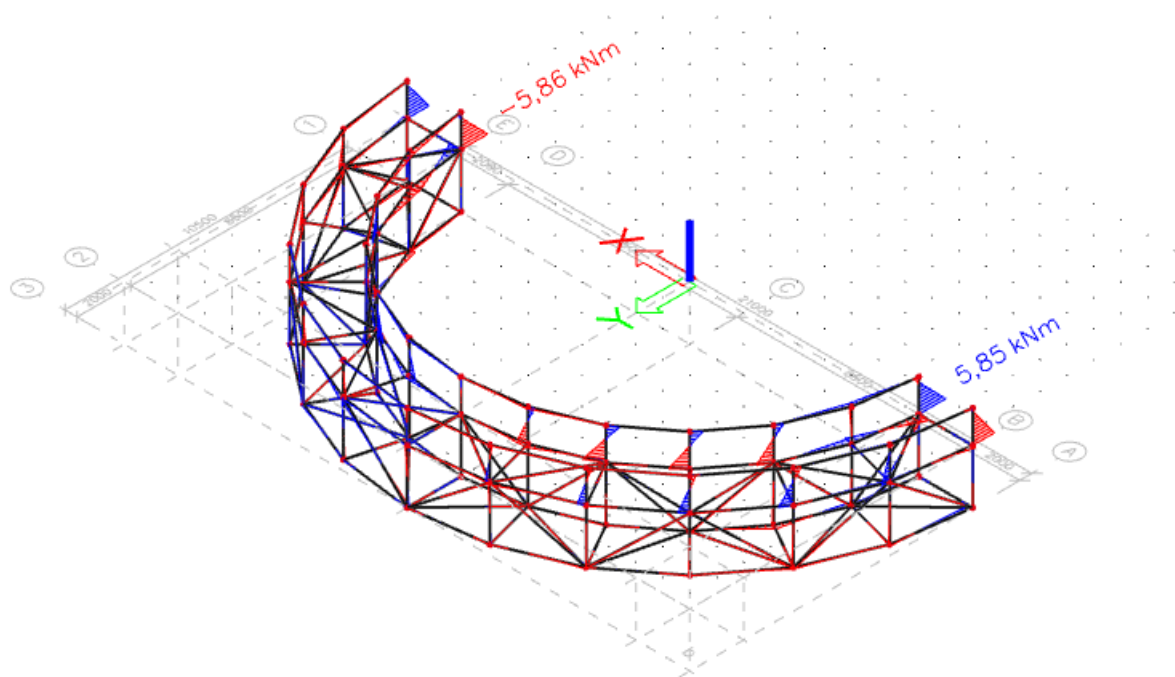

Slika 2.2.5.3. Momentni dijagram opterećenja kombinacije 5 – M_z (kNm)

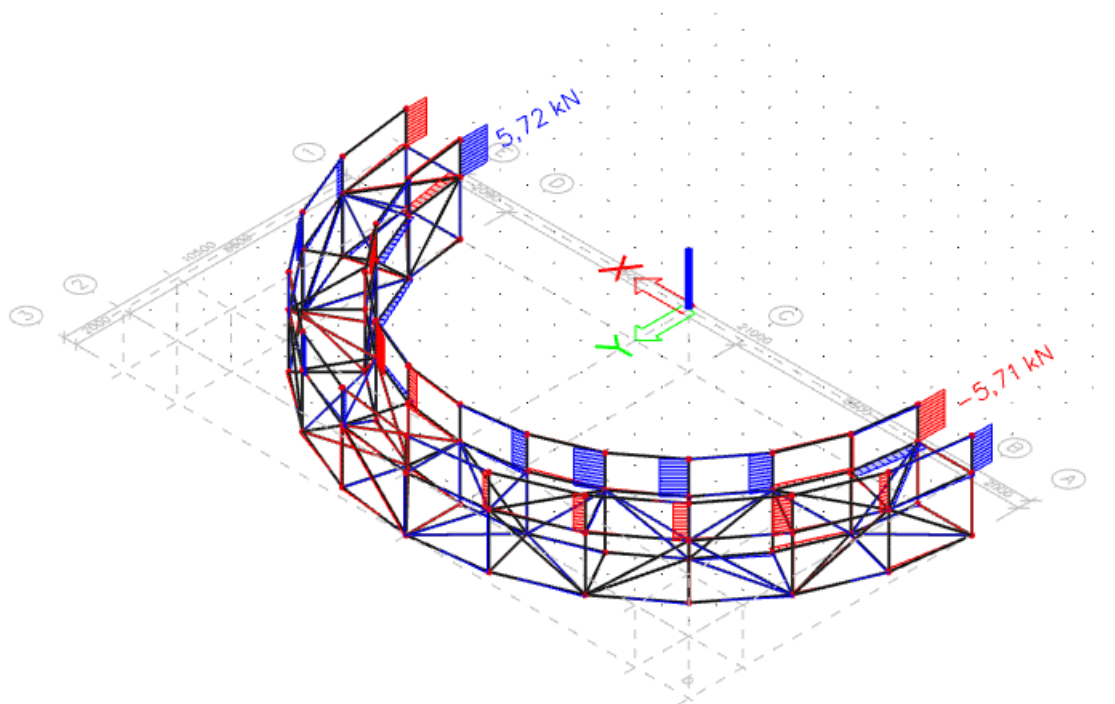

Slika 2.2.5.4. Dijagram poprečnih sila opterećenja kombinacije 5 – V_y (kN)

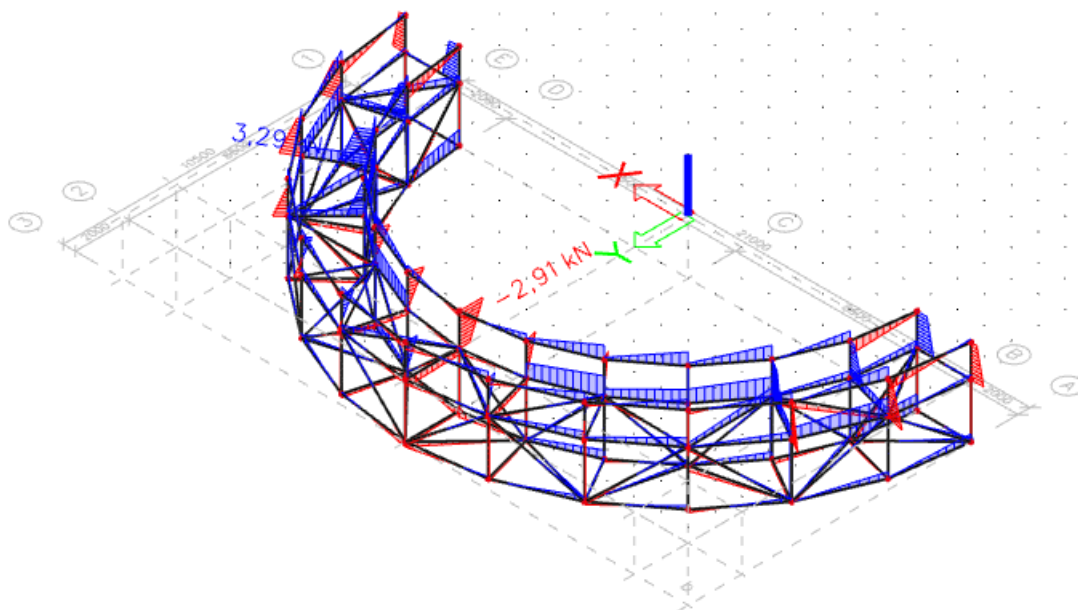
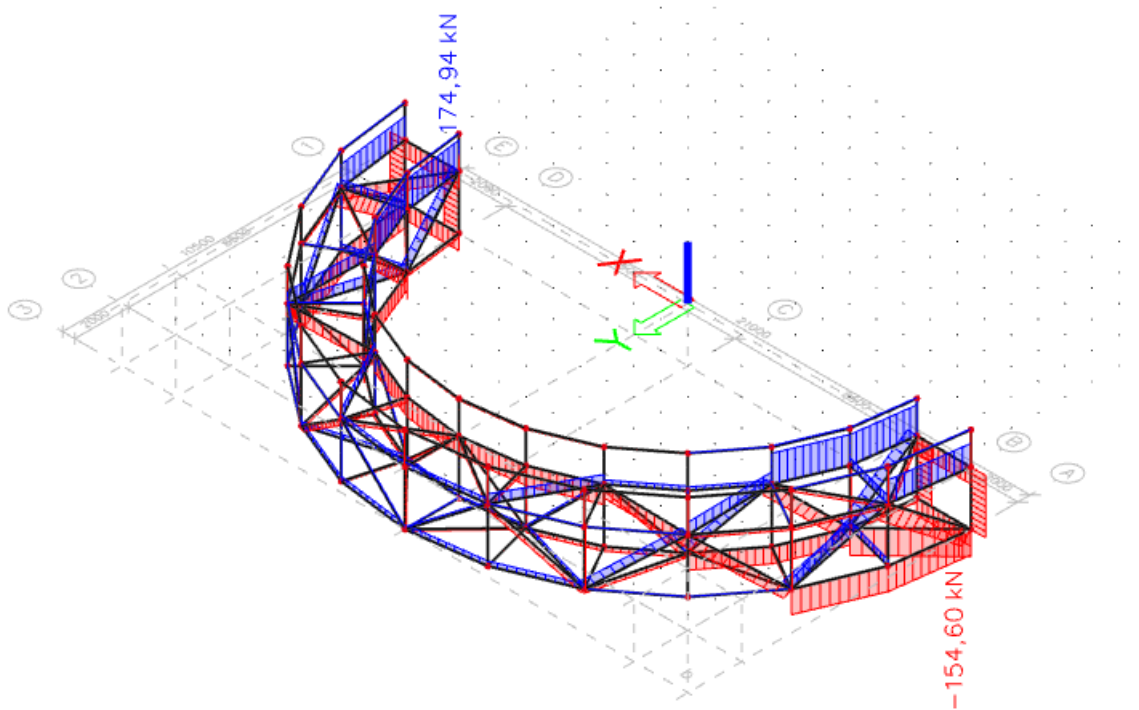
Slika 2.2.5.5. Dijagram poprečnih sila opterećenja kombinacije 5 – V_z (kN)Slika 2.2.5.6. Dijagram uzdužnih sila opterećenja kombinacije 5 – N (kN)

3.2.6. Kombinacija djelovanja 6

$$K_6 = 1,35 \cdot V.T + 0,8 \cdot S + 0,3 \cdot F_w + 1,5 \cdot T_{\min}$$

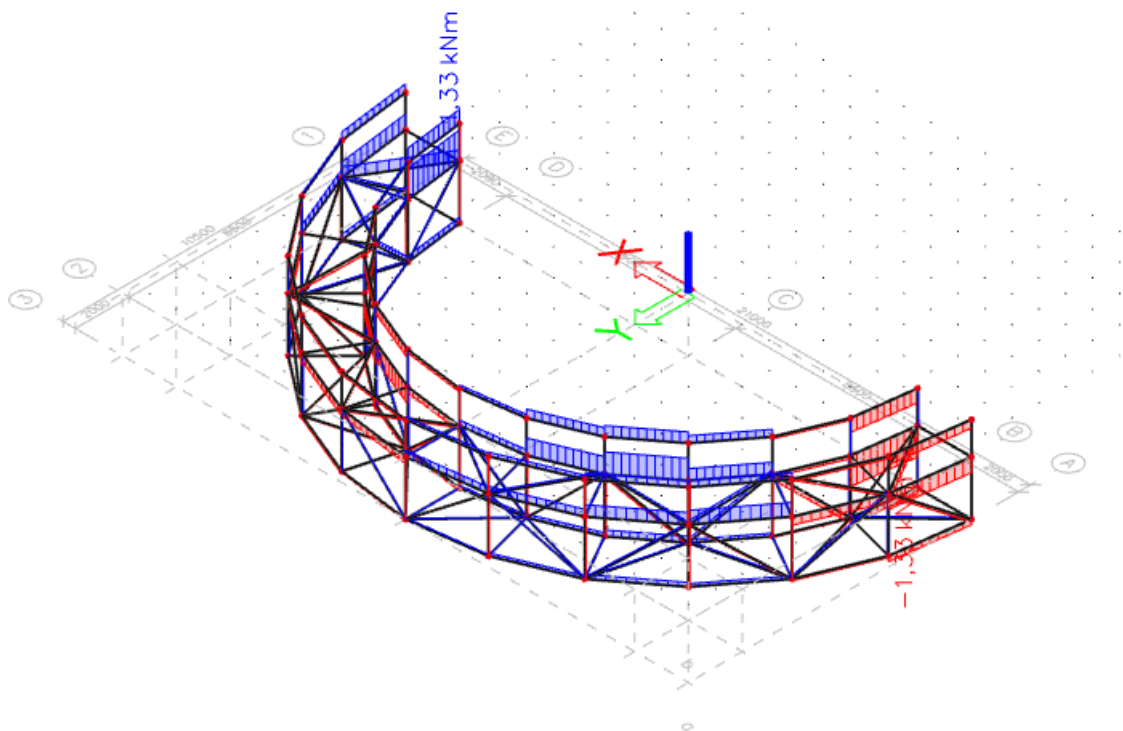

Slika 2.2.6.1. Momentni dijagram opterećenja kombinacije 6 – Mx (kNm)

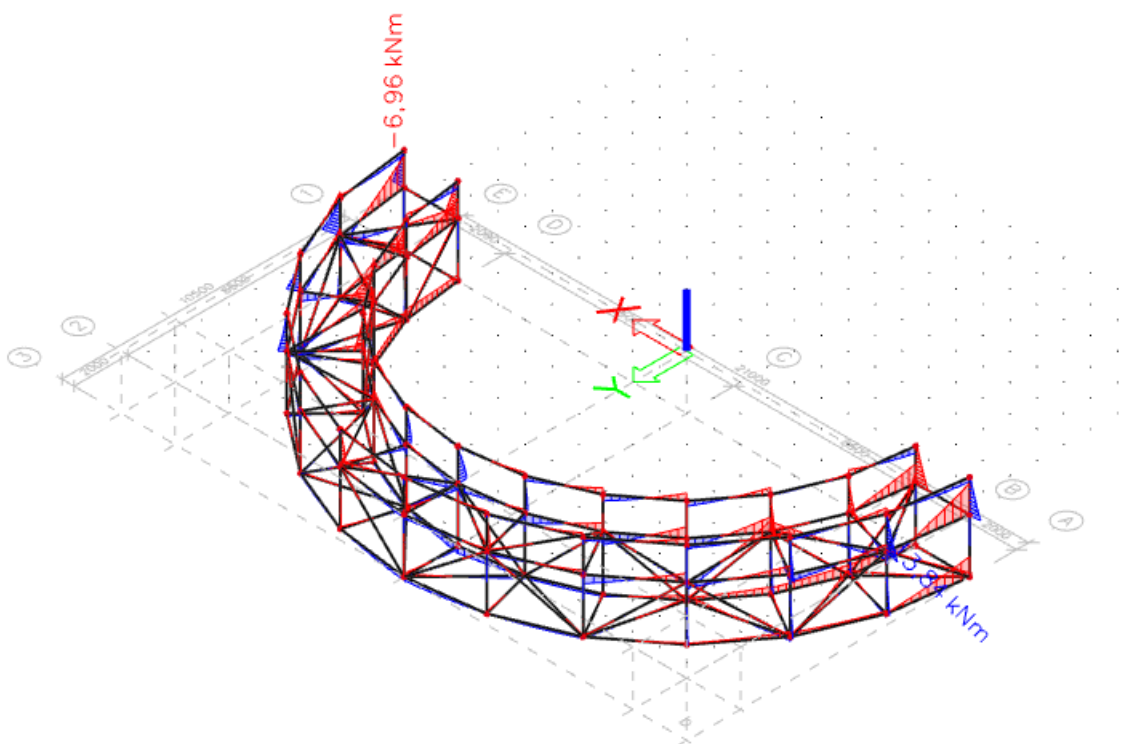

Slika 2.2.6.2. Momentni dijagram opterećenja kombinacije 6 – My (kNm)

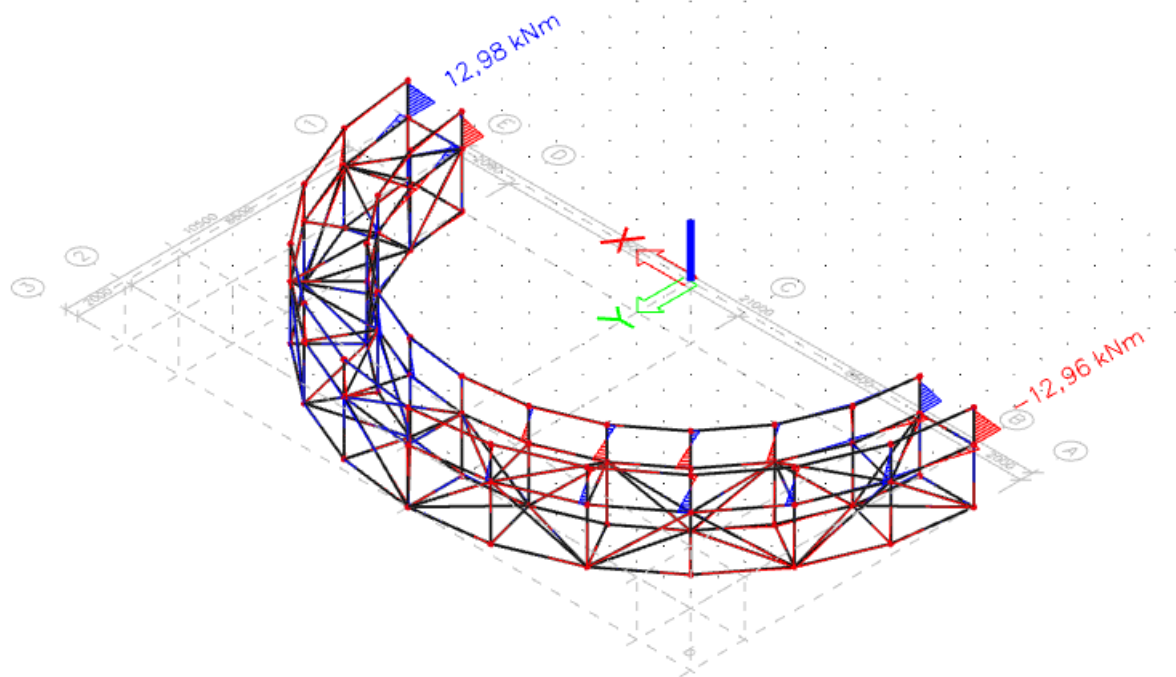

Slika 2.2.6.3. Momentni dijagram opterećenja kombinacije 6 – M_z (kNm)

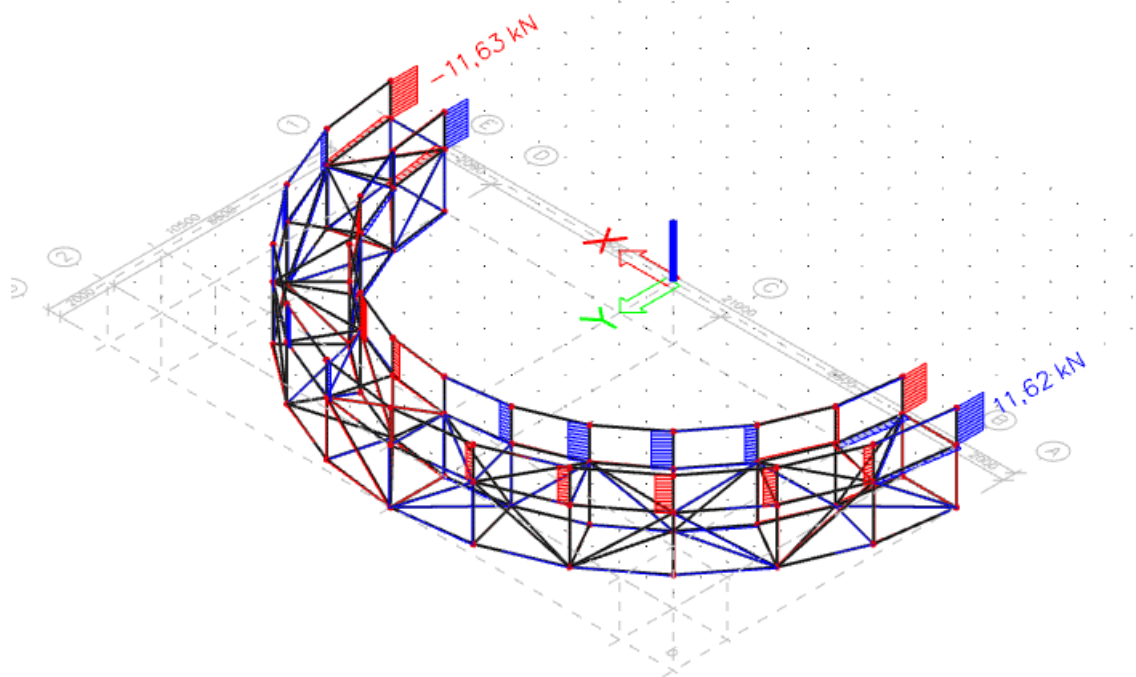

Slika 2.2.6.4. Dijagram poprečnih sila opterećenja kombinacije 6 – V_y (kN)

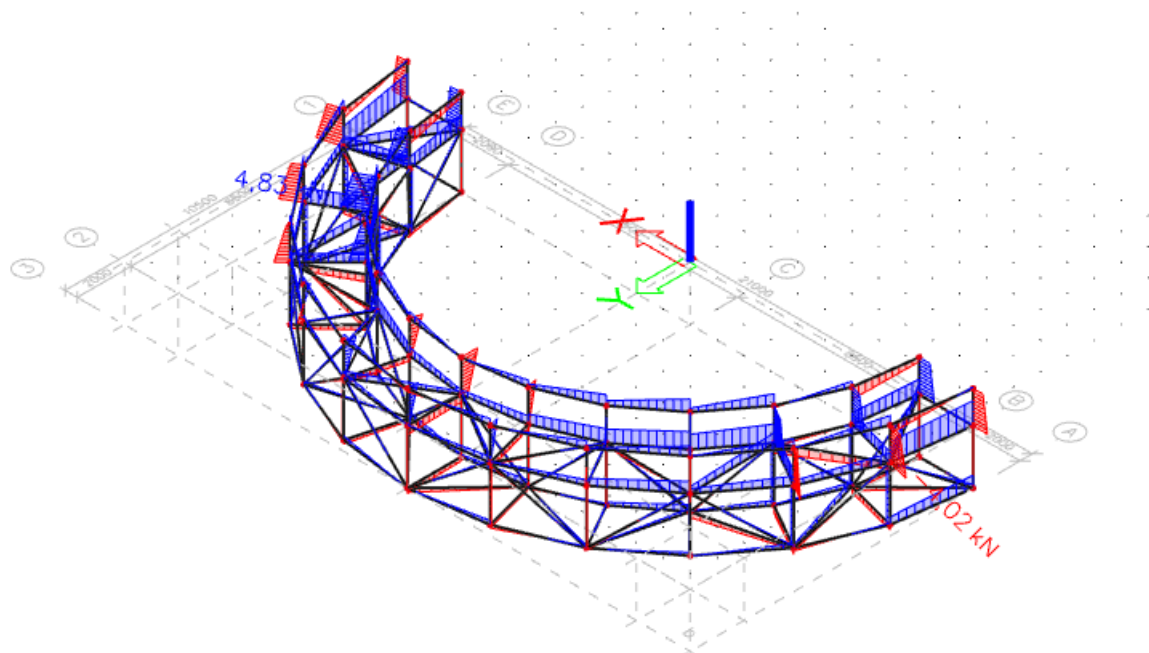

Slika 2.2.6.5. Dijagram poprečnih sila opterećenja kombinacije 6 – Vz (kN)

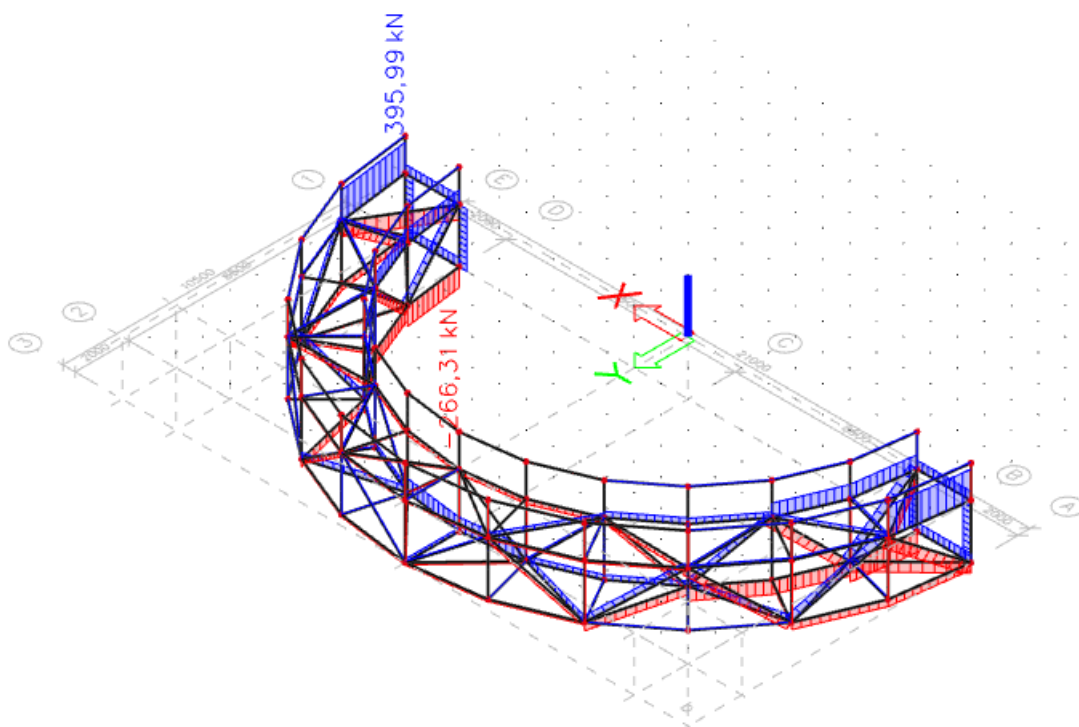

Slika 2.2.6.6. Dijagram uzdužnih sila opterećenja kombinacije 6 – N (kN)

3.3. Granično stanje uporabljivosti

Hod pješaka može izazvati značajne vibracije pješačkih mostova. Da bi se osigurala udobnost korisnika pješačkih mostova potrebno je zadovoljiti norme za granična stanja uporabljivosti.

Kriteriji udobnosti za pješake (za uporabljivost)

1. Kriterije komfora treba definirati najvećim prihvatljivim ubrzanjem bilo kojeg dijela rasponskoga sklopa:

NAPOMENA: Odgovarajući kriteriji smiju se definirati u nacionalnom dodatku ili za pojedini projekt. Preporučuju se sljedeće najveće vrijednosti ubrzanja (m/s^2) bilo kojeg dijela rasponskoga sklopa

- a) 0,7 za vertikalne vibracije
- b) 0,2 za horizontalne vibracije pri uobičajenoj upotrebi
- c) 0,4 za uvjete izuzetnog gomilanja ljudi.

2. Provjeru kriterija udobnosti treba provesti ako je osnovna frekvencija rasponskoga sklop manja od

- a) 5 Hz za vertikalne vibracije
- b) 2,5 za horizontalne (bočne) i torzijske vibracije (2)

U nastavku su prikazane frekvencije za tropojasnu i četveropojasnu rešetku. Budući da su u oba slučaja frekvencije veće od 5 Hz – nije potrebna provjera kriterija udobnosti.

Eigen frequencies				
N	f [Hz]	ω [1/s]	ω^2 [1/s ²]	T [s]
Mass combination : CM1				
1	6,01	37,75	1424,69	0,17
2	10,37	65,17	4247,00	0,10
3	13,24	83,19	6920,90	0,08
4	14,08	88,45	7823,49	0,07
5	15,92	100,01	10002,77	0,06
6	15,92	100,05	10009,04	0,06
7	17,00	106,80	11406,84	0,06
8	17,48	109,85	12066,51	0,06
9	18,10	113,75	12939,35	0,07
10	18,62	117,00	13689,97	0,05

Tablica 2.3.1. Prikaz frekvencija za tropojasnu rešetku

Eigen frequencies

N	f [Hz]	ω [1/s]	ω^2 [1/s ²]	T [s]
Mass combination : CM1				
1	5,93	37,26	1388,14	0,17
2	11,38	71,49	5110,65	0,09
3	13,57	85,26	7269,89	0,07
4	13,72	86,20	7429,95	0,07
5	14,38	90,33	8160,02	0,07
6	14,47	90,91	8265,22	0,07
7	14,48	90,98	8277,85	0,07
8	15,77	99,06	9812,71	0,06
9	15,96	100,30	10059,27	0,06
10	16,84	105,84	11201,10	0,06

Tablica 2.3.2.. Prikaz frekvencija za četveropojasnu rešetku

4. DIMENZIONIRANJE ČELIČNE KONSTRUKCIJE

4.1. Dimenzioniranje tropojasne čelične konstrukcije

4.1.1. Gornji pojas

Gornji pojas sastoji se od dva poprečna presjeka. Unutarnja strana prvog polja gornjeg pojasa je dimenzija 180x120x8 (mm) dok su na ostalim dijelovima gornjeg pojasa odabrani profili dimenzija 180x100x5 (mm).

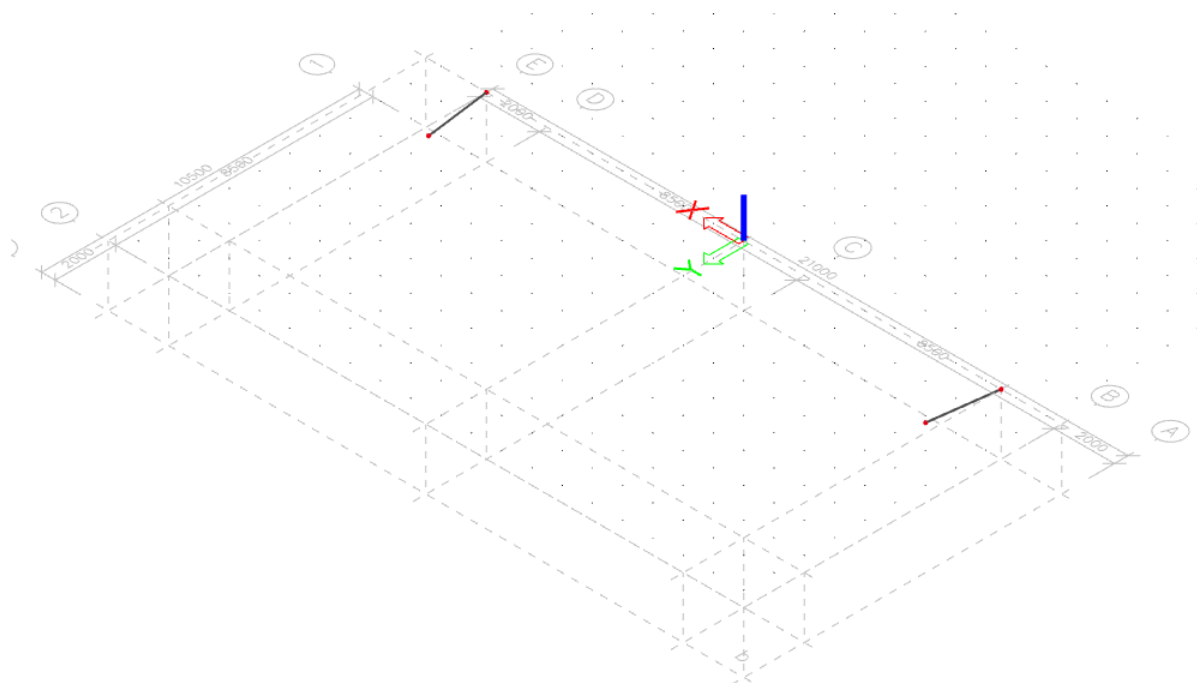

Slika 3.1.1.1. Prikaz položaja poprečnog presjeka

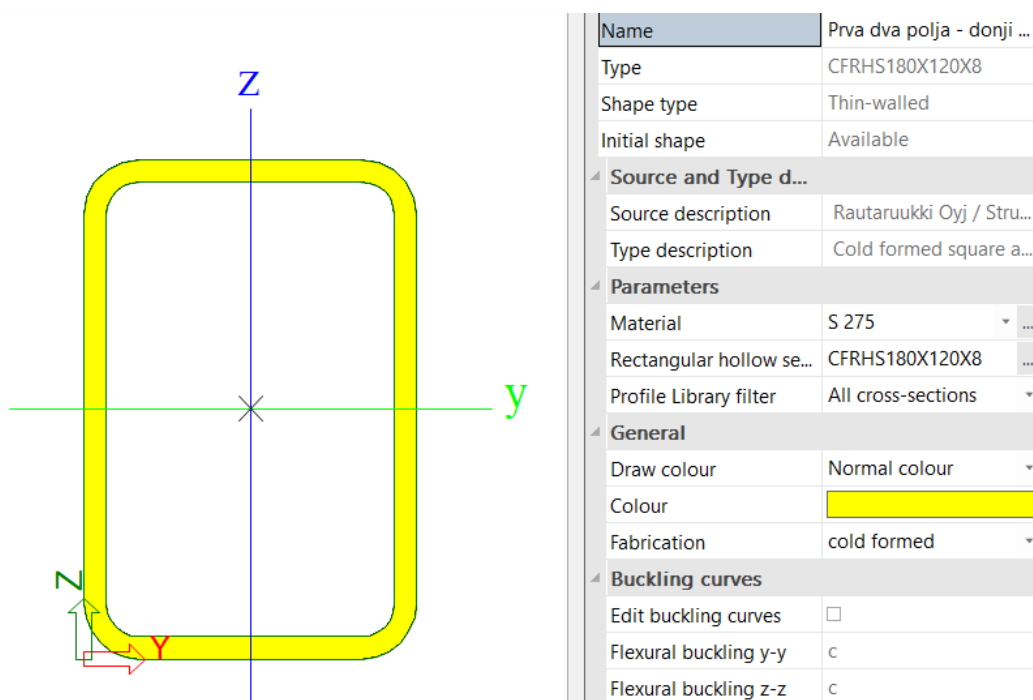

Slika 3.1.1.2. Poprečni presjek unutarnje strane prvog polja gornjeg pojasa

EC-EN 1993 Steel check ULS

Linear calculation

Combination: 1.

Coordinate system: Principal

Extreme 1D: Global

Selection: B16, B143

EN 1993-1-1 Code Check

National annex: Standard EN

Member B16 0,000 / 2,219 m CFRHS180X120XB S 275 1. 0,45 -

Note: EN 1993-1-3 article 1.1(3) specifies that this part does not apply to cold formed CHS and RHS sections. The default EN 1993-1-1 code check is executed instead of the EN 1993-1-3 code check.

Combination key

1. / 1.35*Vlastita težina + 1.50*snijeg + 0.30*vjetar + 0.60*temperatura -

Partial safety factors

γ_{M0} for resistance of cross-sections	1,00
γ_{M1} for resistance to instability	1,00
γ_{M2} for resistance of net sections	1,25

Material

Yield strength	f_y	275,0	MPa
Ultimate strength	f_u	430,0	MPa
Fabrication		Cold formed	

.....SECTION CHECK:....

The critical check is on position 0,000 m

Internal forces		Calculated	Unit
Normal force	N_{Ed}	533,79	kN
Shear force	$V_{y,Ed}$	6,96	kN
Shear force	$V_{x,Ed}$	19,44	kN
Torsion	T_{Ed}	-3,52	kNm
Bending moment	$M_{y,Ed}$	-29,07	kNm
Bending moment	$M_{x,Ed}$	-9,60	kNm

Classification for cross-section design

Classification according to EN 1993-1-1 article 5.5.2

Classification of Internal and Outstand parts according to EN 1993-1-1 Table 5.2 Sheet 1 & 2

Id	Type	c [mm]	t [mm]	σ_1 [kN/m ²]	σ_2 [kN/m ²]	ψ [-]	k_G [-]	α [-]	c/t [-]	Class 1 Limit [-]	Class 2 Limit [-]	Class 3 Limit [-]	Class
1	I	96	8	5,993e+04	-3,433e+04	-0,57		0,64	12,00	46,65	55,14	77,34	1
3	I	156	8	-5,486e+04	-3,020e+05								
5	I	96	8	-3,069e+05	-2,126e+05								
7	I	156	8	-1,921e+05	5,510e+04	-3,49		0,22	19,50	149,28	172,09	480,00	1

Note: The Classification limits have been set according to Semi-Comp+. The cross-section is classified as Class 1

Tension check

According to EN 1993-1-1 article 6.2.3 and formula (6.5)

Cross-section area	A	4,3240e-03	m ²
Plastic tension resistance	$N_{pl,Rd}$	1189,10	kN
Ultimate tension resistance	$N_{u,Rd}$	1338,71	kN
Tension resistance	$N_{t,Rd}$	1189,10	kN
Unity check		0,45	-

Bending moment check for M_y

According to EN 1993-1-1 article 6.2.5 and formula (6.12),(6.13)

Plastic section modulus	$W_{pl,y}$	2,5314e-04	m ³
Plastic bending moment	$M_{pl,y,Rd}$	69,61	kNm
Unity check		0,42	-

Bending moment check for M_x

According to EN 1993-1-1 article 6.2.5 and formula (6.12),(6.13)

Plastic section modulus	$W_{pl,x}$	1,9157e-04	m ³
Plastic bending moment	$M_{pl,x,Rd}$	52,68	kNm
Unity check		0,18	-

Shear check for V_y

According to EN 1993-1-1 article 6.2.6 and formula (6.17)

Shear correction factor	η	1,20	
Shear area	A_v	1,7296e-03	m ²
Plastic shear resistance for V_y	$V_{pl,y,Rd}$	274,61	kN
Unity check		0,03	-

Shear check for V_x

According to EN 1993-1-1 article 6.2.6 and formula (6.17)

Shear correction factor	η	1,20	
Shear area	A_v	2,5944e-03	m ²
Plastic shear resistance for V_x	$V_{pl,Rd}$	411,92	kN
Unity check		0,05	-

Torsion check

According to EN 1993-1-1 article 6.2.7 and formula (6.23)

Index of fibre	Fibre	I	
Total torsional moment	T_{Ed}	11,4	MPa
Elastic shear resistance	T_{Rd}	158,8	MPa
Unity check		0,07	-

Combined Shear and Torsion check for V_y and $\tau_{x,Ed}$

According to EN 1993-1-1 article 6.2.6 & 6.2.7 and formula (6.25),(6.28)

Plastic shear resistance for V_y and T_{Ed}	$V_{pl,T,y,Rd}$	254,85	kN
Unity check		0,03	-

Combined Shear and Torsion check for V_z and $\tau_{x,Ed}$

According to EN 1993-1-1 article 6.2.6 & 6.2.7 and formula (6.25),(6.28)

Plastic shear resistance for V_z and T_{Ed}	$V_{pl,T,z,Rd}$	382,27	kN
Unity check		0,05	-

Combined bending, axial force and shear force check

According to EN 1993-1-1 article 6.2.9.1 and formula (6.41)

Design plastic moment resistance reduced due to N_{Ed}	$M_{N,y,Rd}$	51,15	kNm
Exponent of bending ratio y	α	2,15	
Design plastic moment resistance reduced due to N_{Ed}	$M_{N,z,Rd}$	34,85	kNm
Exponent of bending ratio z	β	2,15	

Unity check (6.41) = 0,30 + 0,06 = 0,36 -

Note: Since the shear forces are less than half the plastic shear resistances their effect on the moment resistances is neglected.

The member satisfies the section check.

...::STABILITY CHECK::...

Classification for member buckling design

Decisive position for stability classification: 0,000 m

Classification according to EN 1993-1-1 article 5.5.2

Classification of Internal and Outstand parts according to EN 1993-1-1 Table 5.2 Sheet 1 & 2

Id	Type	c [mm]	t [mm]	σ_1 [kN/m ²]	σ_2 [kN/m ²]	Ψ [-]	k_{σ} [-]	α [-]	c/t [-]	Class 1 Limit [-]	Class 2 Limit [-]	Class 3 Limit [-]	Class
1	I	96	8	5,993e+04	-3,433e+04	-0,57		0,64	12,00	46,65	55,14	77,34	1
3	I	156	8	-5,486e+04	-3,020e+05								
5	I	96	8	-3,069e+05	-2,126e+05								
7	I	156	8	-1,921e+05	5,510e+04	-3,49		0,22	19,50	149,28	172,09	480,00	1

Note: The Classification limits have been set according to Semi-Comp+.

The cross-section is classified as Class 1

Lateral Torsional Buckling check

According to EN 1993-1-1 article 6.3.2.1

Note: The cross-section concerns an RHS section with $h/b < 10 / \lambda_{eff,z}$. This section is thus not susceptible to Lateral Torsional Buckling.

The member satisfies the stability check.

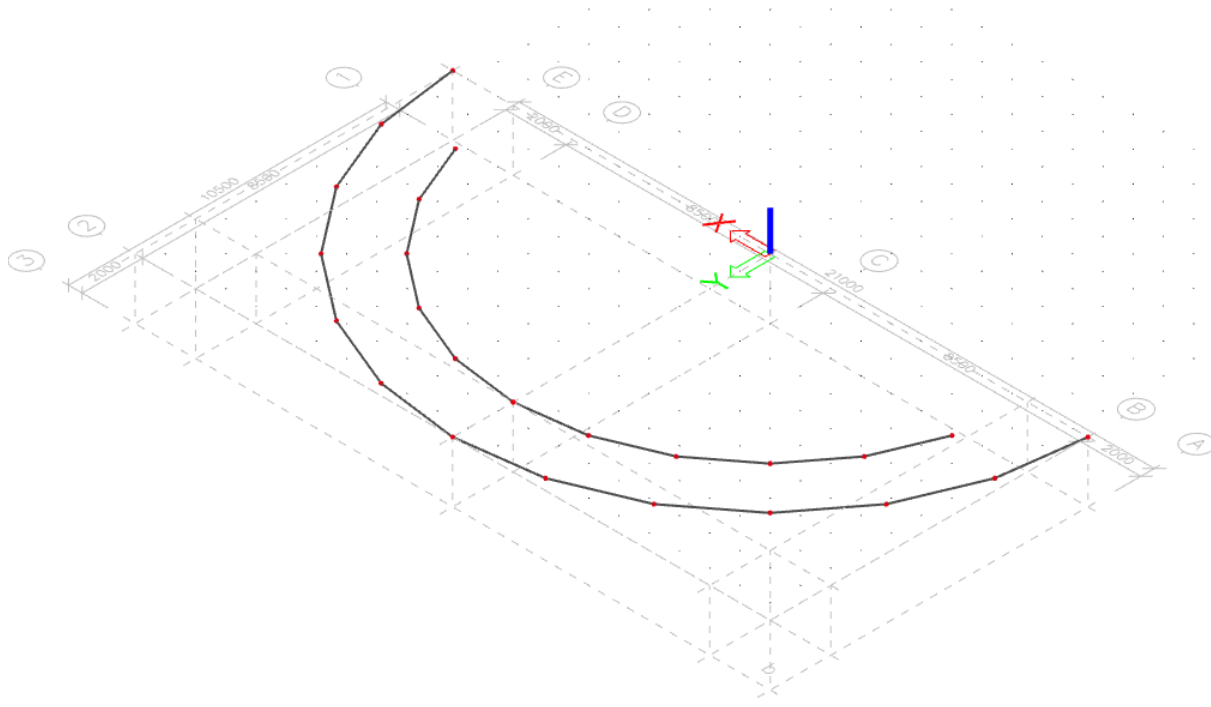

Slika 3.1.1.3. Prikaz položaja poprečnog presjeka

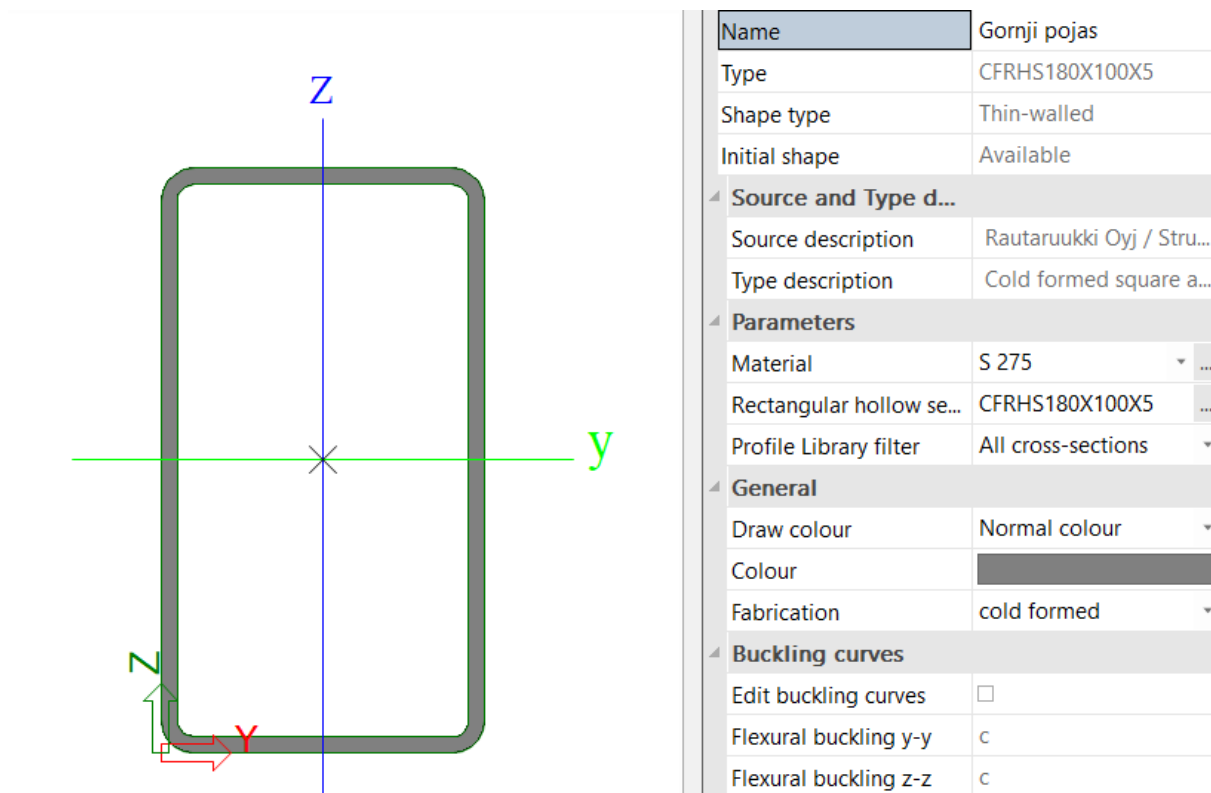

Slika 3.1.1.4. Poprečni presjek gornjeg pojasa na ostalim poljima

EC-EN 1993 Steel check ULS

Linear calculation

Combination: 1.

Coordinate system: Principal

Extreme 1D: Global

Selection: B17..B19, B21, B22, B24, B25, B27, B28, B30, B31, B144..B146, B148, B149, B151, B152, B154, B155, B157, B158

EN 1993-1-1 Code Check

National annex: Standard EN

Member B17	0,000 / 2,741 m	CFRHS180X100X5	S 275	1.	0,43 -
-------------------	------------------------	-----------------------	--------------	-----------	---------------

Note: EN 1993-1-3 article 1.1(3) specifies that this part does not apply to cold formed CHS and RHS sections. The default EN 1993-1-1 code check is executed instead of the EN 1993-1-3 code check.

Combination key	
1. / 1.35*	Vlastita težina + 1.50*srijeg + 0.30*vjetar + 0.60*temperatura -

Partial safety factors	
γ_{M0} for resistance of cross-sections	1,00
γ_{M1} for resistance to instability	1,00
γ_{M2} for resistance of net sections	1,25

Material			
Yield strength	f_y	275,0	MPa
Ultimate strength	f_u	430,0	MPa
Fabrication		Cold formed	

.....SECTION CHECK:....

The critical check is on position **0,000 m**

Internal forces		Calculated	Unit
Normal force	N_{Ed}	310,04	kN
Shear force	$V_{y,Ed}$	1,89	kN
Shear force	$V_{x,Ed}$	-1,93	kN
Torsion	T_{Ed}	-2,11	kNm
Bending moment	$M_{y,Ed}$	1,46	kNm
Bending moment	$M_{x,Ed}$	-2,70	kNm

Classification for cross-section design

Classification according to EN 1993-1-1 article 5.5.2

Classification of Internal and Outstand parts according to EN 1993-1-1 Table 5.2 Sheet 1 & 2

Id	Type	c [mm]	t [mm]	σ_1 [kN/m ²]	σ_2 [kN/m ²]	ψ [-]	k_{σ} [-]	α [-]	c/t [-]	Class 1 Limit [-]	Class 2 Limit [-]	Class 3 Limit [-]	Class
1	I	85	5	-1,036e+05	-1,545e+05								
3	I	165	5	-1,568e+05	-1,354e+05								
5	I	85	5	-1,317e+05	-8,083e+04								
7	I	165	5	-7,849e+04	-9,994e+04								

Note: The Classification limits have been set according to Semi-Comp+. The cross-section is classified as Class 1

Tension check

According to EN 1993-1-1 article 6.2.3 and formula (6.5)

Cross-section area	A	2,6360e-03	m ²
Plastic tension resistance	$N_{pl,Rd}$	724,90	kN
Ultimate tension resistance	$N_{u,Rd}$	816,11	kN
Tension resistance	$N_{t,Rd}$	724,90	kN
Unity check		0,43	-

Bending moment check for M_y

According to EN 1993-1-1 article 6.2.5 and formula (6.12),(6.13)

Plastic section modulus	$W_{pl,y}$	1,5402e-04	m ³
Plastic bending moment	$M_{pl,y,Rd}$	42,36	kNm
Unity check		0,03	-

Bending moment check for M_x

According to EN 1993-1-1 article 6.2.5 and formula (6.12),(6.13)

Plastic section modulus	$W_{pl,z}$	1,0259e-04	m ³
Plastic bending moment	$M_{pl,z,Rd}$	28,21	kNm
Unity check		0,10	-

Shear check for V_y

According to EN 1993-1-1 article 6.2.6 and formula (6.17)

Shear correction factor	η	1,20	
Shear area	A_v	9,4143e-04	m ²
Plastic shear resistance for V_y	$V_{pl,Rd}$	149,47	kN
Unity check		0,01	-

Shear check for V_z

According to EN 1993-1-1 article 6.2.6 and formula (6.17)

Shear correction factor	η	1,20	
Shear area	A_v	1,6946e-03	m ²
Plastic shear resistance for V_z	$V_{pl,z,Rd}$	259,05	kN
Unity check		0,01	-

Torsion check

According to EN 1993-1-1 article 6.2.7 and formula (6.23)

Index of fibre	Fibre	1	
Total torsional moment	T_{Ed}	12,7	MPa
Elastic shear resistance	τ_{Rd}	158,8	MPa
Unity check		0,08	-

Combined Shear and Torsion check for V_y and $\tau_{t,Ed}$

According to EN 1993-1-1 article 6.2.6 & 6.2.7 and formula (6.25),(6.28)

Plastic shear resistance for V_y and T_{Ed}	$V_{pl,T,y,Rd}$	137,52	kN
Unity check		0,01	-

Combined Shear and Torsion check for V_z and $\tau_{t,Ed}$

According to EN 1993-1-1 article 6.2.6 & 6.2.7 and formula (6.25),(6.28)

Plastic shear resistance for V_z and T_{Ed}	$V_{pl,T,z,Rd}$	247,53	kN
Unity check		0,01	-

Combined bending, axial force and shear force check

According to EN 1993-1-1 article 6.2.9.1 and formula (6.41)

Design plastic moment resistance reduced due to N_{Ed}	$M_{N,y,Rd}$	32,32	kNm
Exponent of bending ratio y	α	2,09	
Design plastic moment resistance reduced due to N_{Ed}	$M_{N,z,Rd}$	19,19	kNm
Exponent of bending ratio z	β	2,09	

Unity check (6.41) = 0,00 + 0,02 = 0,02 -

Note: Since the shear forces are less than half the plastic shear resistances their effect on the moment resistances is neglected.

The member satisfies the section check.

....**STABILITY CHECK**....**Classification for member buckling design**

Decisive position for stability classification: 0,000 m

Classification according to EN 1993-1-1 article 5.5.2

Classification of Internal and Outstand parts according to EN 1993-1-1 Table 5.2 Sheet 1 & 2

Id	Type	c [mm]	t [mm]	σ_1 [kN/m ²]	σ_2 [kN/m ²]	ψ [-]	k_{σ} [-]	α [-]	c/t [-]	Class 1 Limit [-]	Class 2 Limit [-]	Class 3 Limit [-]	Class
1	I	85	5	-1,036e+05	-1,545e+05								
3	I	165	5	-1,568e+05	-1,354e+05								
5	I	85	5	-1,317e+05	-8,083e+04								
7	I	165	5	-7,849e+04	-9,994e+04								

Note: The Classification limits have been set according to Semi-Comp+. The cross-section is classified as Class 1**Lateral Torsional Buckling check**

According to EN 1993-1-1 article 6.3.2.1

Note: The cross-section concerns an RHS section with $h/b < 10 / \lambda_{rel,z}^2$.

This section is thus not susceptible to Lateral Torsional Buckling.

The member satisfies the stability check.

4.1.2. Donji pojas

Donji pojas sastoji se od dva poprečna presjeka. Prvo i drugo polje donjeg pojasa je dimenzija 180x120x8 (mm) dok su na ostalim dijelovima donjeg pojasa odabrani profili dimenzija 180x100x5 (mm).

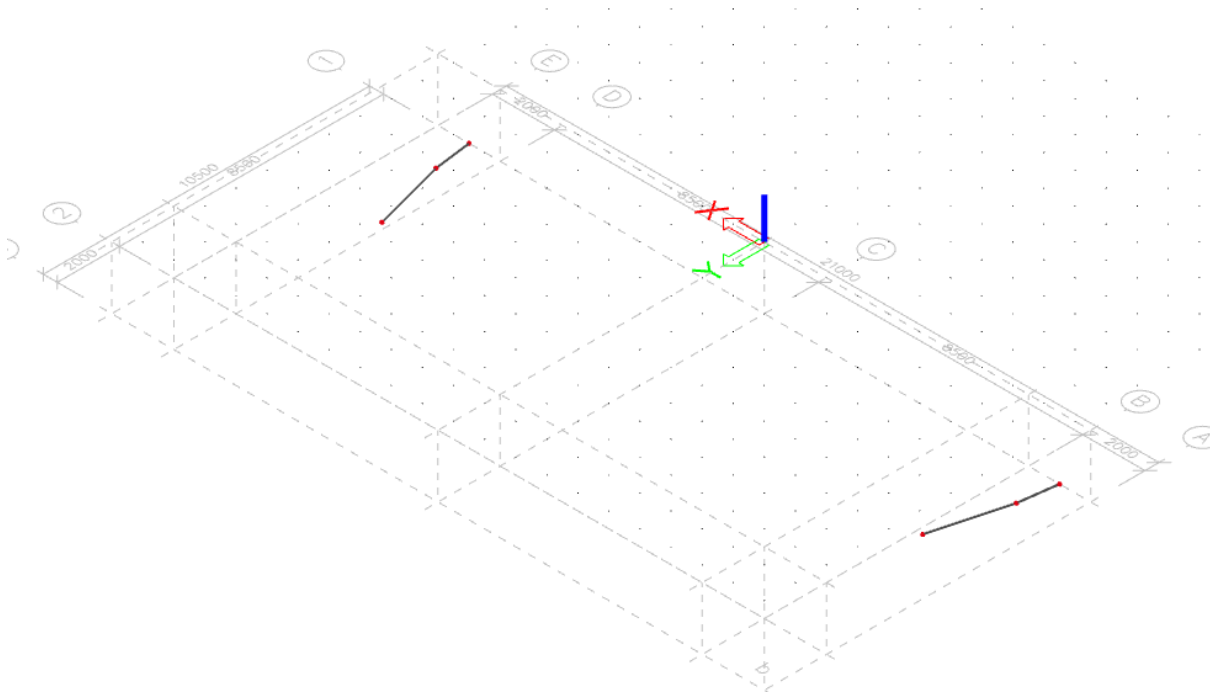

Slika 3.1.2.1. Prikaz položaja poprečnog presjeka

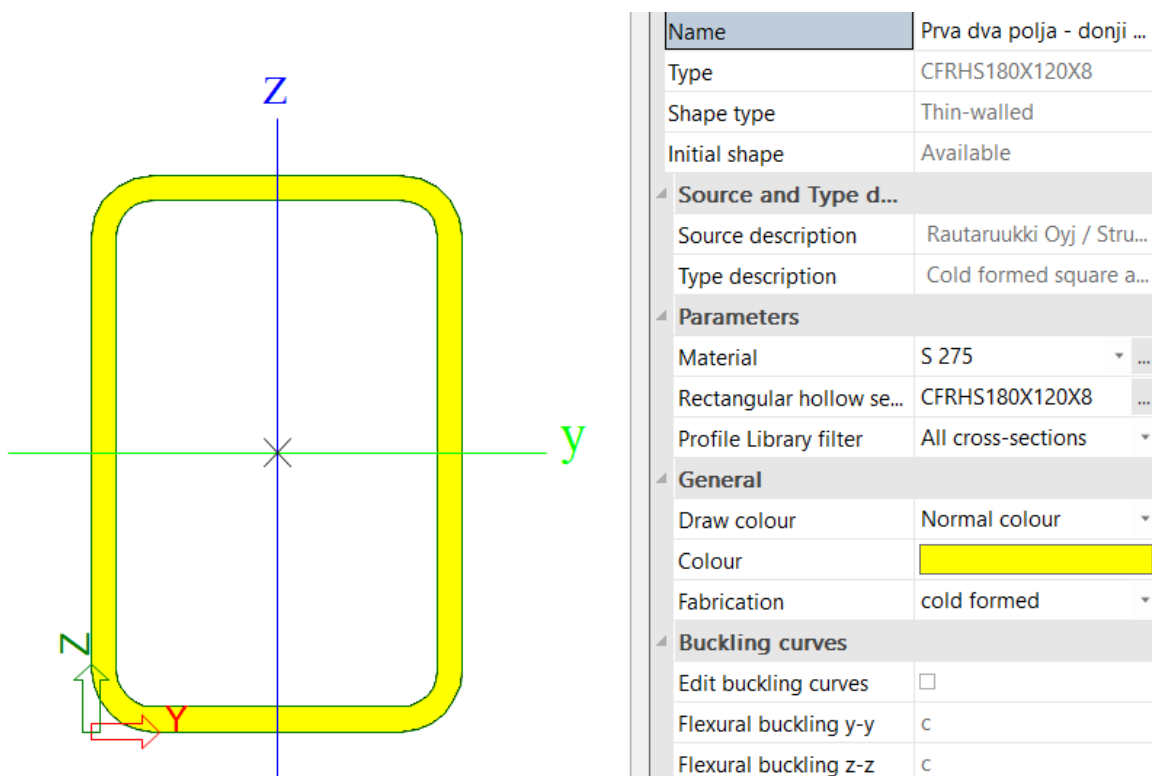

Slika 3.1.2.2. Poprečni presjek donjeg pojasa na prva dva polja

EC-EN 1993 Steel check ULS

Linear calculation

Combination: 1.

Coordinate system: Principal

Extreme 1D: Global

Selection: B99, B130, B183, B194

EN 1993-1-1 Code Check

National annex: Standard EN

Member B194 0,000 / 1,240 m **CFRHS180X120X8** **S 275** **1.** **0,99 -**

Note: EN 1993-1-3 article 1.1(3) specifies that this part does not apply to cold formed CHS and RHS sections.
The default EN 1993-1-1 code check is executed instead of the EN 1993-1-3 code check.

Combination key

1. / 1.35*Vlastita težina + 1.50*snijeg + 0.30*vjetar + 0.60*temperatura -

Partial safety factors

γ_{M0} for resistance of cross-sections	1,00
γ_{M1} for resistance to instability	1,00
γ_{M2} for resistance of net sections	1,25

Material

Yield strength	f_y	275,0	MPa
Ultimate strength	f_u	430,0	MPa
Fabrication		Cold formed	

....SECTION CHECK:....

The critical check is on position 0,000 m

Internal forces		Calculated	Unit
Normal force	N_{Ed}	-871,97	kN
Shear force	$V_{y,Ed}$	16,70	kN
Shear force	$V_{z,Ed}$	17,73	kN
Torsion	T_{Ed}	2,87	kNm
Bending moment	$M_{y,Ed}$	-19,12	kNm
Bending moment	$M_{z,Ed}$	-14,44	kNm

Classification for cross-section design

Classification according to EN 1993-1-1 article 5.5.2

Classification of Internal and Outstand parts according to EN 1993-1-1 Table 5.2 Sheet 1 & 2

Id	Type	c [mm]	t [mm]	σ_1 [kN/m ²]	σ_2 [kN/m ²]	W [-]	k_{σ} [-]	α [-]	c/t [-]	Class 1 Limit [-]	Class 2 Limit [-]	Class 3 Limit [-]	Class
1	I	96	8	3,622e+05	2,205e+05	0,61		1,00	12,00	25,88	31,43	40,65	1
3	I	156	8	2,003e+05	3,774e+04	0,19		1,00	19,50	25,88	31,43	48,90	1
5	I	96	8	4,121e+04	1,829e+05	0,23		1,00	12,00	25,88	31,43	48,04	1
7	I	156	8	2,030e+05	3,656e+05	0,56		1,00	19,50	25,88	31,43	41,54	1

Note: The Classification limits have been set according to Semi-Comp+.

The cross-section is classified as Class 1

Compression check

According to EN 1993-1-1 article 6.2.4 and formula (6.9)

Cross-section area	A	4,3240e-03	m ²
Compression resistance	$N_{c,Rd}$	1189,10	kN
Unity check		0,73	-

Bending moment check for M_y

According to EN 1993-1-1 article 6.2.5 and formula (6.12),(6.13)

Plastic section modulus	$W_{pl,y}$	2,5314e-04	m ³
Plastic bending moment	$M_{pl,y,Rd}$	69,61	kNm
Unity check		0,27	-

Bending moment check for M_z

According to EN 1993-1-1 article 6.2.5 and formula (6.12),(6.13)

Plastic section modulus	$W_{pl,z}$	1,9157e-04	m ³
Plastic bending moment	$M_{pl,z,Rd}$	52,68	kNm
Unity check		0,27	-

Shear check for V_y

According to EN 1993-1-1 article 6.2.6 and formula (6.17)

Shear correction factor	η	1,20	
Shear area	A_v	1,7296e-03	m ²
Plastic shear resistance for V_y	$V_{pl,y,Rd}$	274,61	kN
Unity check		0,06	-

Shear check for V_z

According to EN 1993-1-1 article 6.2.6 and formula (6.17)

Shear correction factor	η	1,20	
Shear area	A_v	2,5944e-03	m ²
Plastic shear resistance for V_z	$V_{pl,z,Rd}$	411,92	kN
Unity check		0,04	-

Torsion check

According to EN 1993-1-1 article 6.2.7 and formula (6.23)

Index of fibre	Fibre	1	
Total torsional moment	T_{Ed}	9,3	MPa
Elastic shear resistance	T_{Rd}	158,8	MPa
Unity check		0,06	-

Combined Shear and Torsion check for V_y and $\tau_{t,Ed}$

According to EN 1993-1-1 article 6.2.6 & 6.2.7 and formula (6.25),(6.28)

Plastic shear resistance for V_y and T_{Ed}	$V_{pl,T,y,Rd}$	258,50	kN
Unity check		0,06	-

Combined Shear and Torsion check for V_z and $\tau_{t,Ed}$

According to EN 1993-1-1 article 6.2.6 & 6.2.7 and formula (6.25),(6.28)

Plastic shear resistance for V_z and T_{Ed}	$V_{pl,T,z,Rd}$	387,75	kN
Unity check		0,05	-

Combined bending, axial force and shear force check

According to EN 1993-1-1 article 6.2.9.1 and formula (6.41)

Design plastic moment resistance reduced due to N_{Ed}	$M_{N,y,Rd}$	24,75	kNm
Exponent of bending ratio γ	α	4,23	
Design plastic moment resistance reduced due to N_{Ed}	$M_{N,z,Rd}$	16,87	kNm
Exponent of bending ratio z	β	4,23	

Unity check (6.41) = $0,34 + 0,52 = 0,85$ -**Note:** Since the shear forces are less than half the plastic shear resistances their effect on the moment resistances is neglected.

The member satisfies the section check.

...::STABILITY CHECK::...

Classification for member buckling design

Decisive position for stability classification: 0,000 m

Classification according to EN 1993-1-1 article 5.5.2

Classification of Internal and Outstand parts according to EN 1993-1-1 Table 5.2 Sheet 1 & 2

Id	Type	c [mm]	t [mm]	σ_1 [kN/m ²]	σ_2 [kN/m ²]	ψ [-]	k_{σ} [-]	α [-]	c/t [-]	Class 1 Limit [-]	Class 2 Limit [-]	Class 3 Limit [-]	Class
1	I	96	8	3,622e+05	2,205e+05	0,61		1,00	12,00	25,88	31,43	40,65	1
3	I	156	8	2,003e+05	3,774e+04	0,19		1,00	19,50	25,88	31,43	48,90	1
5	I	96	8	4,121e+04	1,829e+05	0,23		1,00	12,00	25,88	31,43	48,04	1
7	I	156	8	2,030e+05	3,656e+05	0,56		1,00	19,50	25,88	31,43	41,54	1

Note: The Classification limits have been set according to Semi-Comp+.

The cross-section is classified as Class 1

Flexural Buckling check

According to EN 1993-1-1 article 6.3.1.1 and formula (6.46)

Buckling parameters		yy	zz	
Sway type		sway	non-sway	
System length	L	1,240	1,240	m
Buckling factor	k	1,00	0,70	
Buckling length	l_{cr}	1,240	0,868	m
Critical Euler load	N_{cr}	24739,49	26916,25	kN
Slenderness	λ	19,03	18,25	
Relative slenderness	λ_{rel}	0,22	0,21	
Limit slenderness	$\lambda_{rel,0}$	0,20	0,20	

Note: The slenderness or compression force is such that Flexural Buckling effects may be ignored according to EN 1993-1-1 article 6.3.1.2(4).**Torsional(-Flexural) Buckling check**

According to EN 1993-1-1 article 6.3.1.1 and formula (6.46)

Note: The cross-section concerns a RHS section which is not susceptible to Torsional(-Flexural) Buckling.**Lateral Torsional Buckling check**

According to EN 1993-1-1 article 6.3.2.1

Note: The cross-section concerns an RHS section with $h / b < 10 / \lambda_{rel,z}^2$. This section is thus not susceptible to Lateral Torsional Buckling.

Bending and axial compression check

According to EN 1993-1-1 article 6.3.3 and formula (6.61),(6.62)

Bending and axial compression check parameters			
Interaction method		alternative method 1	
Cross-section area	A	4,3240e-03	m ²
Plastic section modulus	$W_{pl,y}$	2,5314e-04	m ³
Plastic section modulus	$W_{pl,z}$	1,9157e-04	m ³
Design compression force	N_{Ed}	871,97	kN
Design bending moment (maximum)	$M_{y,Ed}$	-19,12	kNm
Design bending moment (maximum)	$M_{z,Ed}$	-14,44	kNm
Characteristic compression resistance	N_{Rk}	1189,10	kN
Characteristic moment resistance	$M_{y,Rk}$	69,61	kNm
Characteristic moment resistance	$M_{z,Rk}$	52,68	kNm
Reduction factor	χ_y	1,00	
Reduction factor	χ_z	1,00	
Reduction factor	χ_{LT}	1,00	
Interaction factor	k_{yy}	0,59	
Interaction factor	k_{yz}	0,34	
Interaction factor	k_{zy}	0,36	
Interaction factor	k_{zz}	0,58	

Maximum moment $M_{y,Ed}$ is derived from beam B194 position 0,000 m.

Maximum moment $M_{z,Ed}$ is derived from beam B194 position 0,000 m.

Interaction method 1 parameters			
Critical Euler load	$N_{cr,y}$	24739,49	kN
Critical Euler load	$N_{cr,z}$	26916,25	kN
Elastic critical load	$N_{cr,T}$	277311,48	kN
Plastic section modulus	$W_{pl,y}$	2,5314e-04	m ³
Elastic section modulus	$W_{el,y}$	2,0393e-04	m ³
Plastic section modulus	$W_{pl,z}$	1,9157e-04	m ³
Elastic section modulus	$W_{el,z}$	1,6307e-04	m ³
Second moment of area	I_y	1,8353e-05	m ⁴
Second moment of area	I_z	9,7844e-06	m ⁴
Torsional constant	I_t	2,1564e-05	m ⁴
Method for equivalent moment factor $C_{my,0}$		Table A.2 Line 1 (Linear)	
Ratio of end moments	ψ_y	-0,13	
Equivalent moment factor	$C_{my,0}$	0,76	
Method for equivalent moment factor $C_{mz,0}$		Table A.2 Line 1 (Linear)	
Ratio of end moments	ψ_z	-0,43	
Equivalent moment factor	$C_{mz,0}$	0,69	
Factor	μ_y	1,00	
Factor	μ_z	1,00	
Factor	ϵ_y	0,46	
Factor	a_{LT}	0,00	
Critical moment for uniform bending	$M_{cr,0}$	4878,55	kNm
Relative slenderness	$\lambda_{rel,0}$	0,12	
Limit relative slenderness	$\lambda_{rel,lim}$	0,27	
Equivalent moment factor	C_{my}	0,76	
Equivalent moment factor	C_{mz}	0,69	
Equivalent moment factor	C_{mLT}	1,00	
Factor	b_{LT}	0,00	
Factor	c_{LT}	0,00	
Factor	d_{LT}	0,00	
Factor	e_{LT}	0,00	
Factor	w_y	1,24	
Factor	w_z	1,17	
Factor	η_{pl}	0,73	
Maximum relative slenderness	$\lambda_{rel,max}$	0,22	
Factor	C_{yy}	1,32	
Factor	C_{yz}	1,24	
Factor	C_{zy}	1,33	
Factor	C_{zz}	1,23	

Unity check (6.61) = $0,73 + 0,16 + 0,09 = 0,99$

Unity check (6.62) = $0,73 + 0,10 + 0,16 = 0,99$

The member satisfies the stability check.

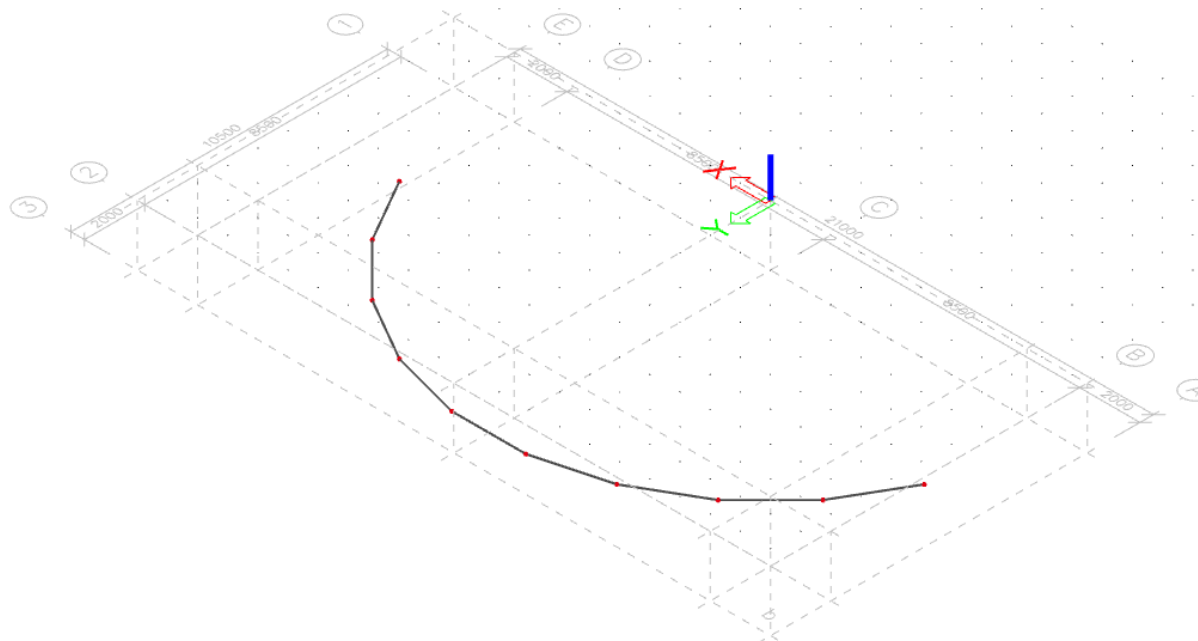

Slika 3.1.2.3. Prikaz položaja poprečnog presjeka

Name	Donji pojas
Type	CFRHS180X100X5
Shape type	Thin-walled
Initial shape	Available
Source and Type d...	
Source description	Rautaruukki Oyj / Stru...
Type description	Cold formed square a...
Parameters	
Material	S 275
Rectangular hollow se...	CFRHS180X100X5
Profile Library filter	All cross-sections
General	
Draw colour	Normal colour
Colour	
Fabrication	cold formed
Buckling curves	
Edit buckling curves	<input type="checkbox"/>
Flexural buckling y-y	c
Flexural buckling z-z	c

Slika 3.1.2.4. Poprečni presjek donjeg pojasa na ostalim poljima

EC-EN 1993 Steel check ULS

Linear calculation

Combination: 1.

Coordinate system: Principal

Extreme 1D: Global

Selection: B131..B134, B184..B187, B195

EN 1993-1-1 Code Check

National annex: Standard EN

Member B184 0,000 / 2,459 m CFRHS180X100X5 S 275 1. 0,83 -

Note: EN 1993-1-3 article 1.1(3) specifies that this part does not apply to cold formed CHS and RHS sections.
The default EN 1993-1-1 code check is executed instead of the EN 1993-1-3 code check.

Combination key

1. / 1.35*Vlastita težina + 1.50*snijeg + 0.30*vjetar +
0.60*temperatura -

Partial safety factors

γ_{M0} for resistance of cross-sections	1,00
γ_{M1} for resistance to instability	1,00
γ_{M2} for resistance of net sections	1,25

Material

Yield strength	f_y	275,0	MPa
Ultimate strength	f_u	430,0	MPa
Fabrication		Cold formed	

.....SECTION CHECK:.....

The critical check is on position 0,000 m

Internal forces		Calculated	Unit
Normal force	N_{Ed}	-331,66	kN
Shear force	$V_{y,Ed}$	-0,90	kN
Shear force	$V_{z,Ed}$	1,56	kN
Torsion	T_{Ed}	-0,34	kNm
Bending moment	$M_{y,Ed}$	-2,73	kNm
Bending moment	$M_{z,Ed}$	1,39	kNm

Classification for cross-section design

Classification according to EN 1993-1-1 article 5.5.2

Classification of Internal and Outstand parts according to EN 1993-1-1 Table 5.2 Sheet 1 & 2

Id	Type	c [mm]	t [mm]	σ_1 [kN/m ²]	σ_2 [kN/m ²]	ψ [-]	k_{σ} [-]	α [-]	c/t [-]	Class 1 Limit [-]	Class 2 Limit [-]	Class 3 Limit [-]	Class
1	I	85	5	1,340e+05	1,602e+05	0,84		1,00	17,00	25,88	31,43	37,24	1
3	I	165	5	1,605e+05	1,205e+05	0,75		1,00	33,00	25,88	31,43	38,45	3
5	I	85	5	1,177e+05	9,155e+04	0,78		1,00	17,00	25,88	31,43	38,07	1
7	I	165	5	9,122e+04	1,312e+05	0,70		1,00	33,00	25,88	31,43	39,28	3

Note: The Classification limits have been set according to Semi-Comp+.

The cross-section is classified as Class 3

Semi-Comp+ properties

Material coefficient	ϵ	0,92	
Flange class 2 slenderness limit	$\beta_{2,y,f}$	31,43	
Flange class 3 slenderness limit	$\beta_{3,y,f}$	35,13	
Web class 2 slenderness limit	$\beta_{2,y,w}$	76,73	
Web class 3 slenderness limit	$\beta_{3,y,w}$	114,63	
Web class 2 slenderness limit	$\beta_{2,z,w}$	31,43	
Web class 3 slenderness limit	$\beta_{3,z,w}$	35,13	
Web slenderness ratio	c/t_w	33,00	
Flange slenderness ratio	c/t_f	17,00	
Reference slenderness ratio	$c/t_{ref,y}$	0,00	
Reference slenderness ratio	$c/t_{ref,z}$	0,42	
Interpolated section modulus	$W_{3,y}$	1,5402e-04	m ³
Interpolated section modulus	$W_{3,z}$	9,7393e-05	m ³

Note: The resistance for this semi-compact section has been calculated according to Semi-Comp+.**Compression check**

According to EN 1993-1-1 article 6.2.4 and formula (6.9)

Cross-section area	A	2,6360e-03	m ²
Compression resistance	$N_{c,Rd}$	724,90	kN
Unity check		0,46	-

Bending moment check for M_y

According to EN 1993-1-1 article 6.2.5 and formula (6.12),(6.13)

Interpolated section modulus	$W_{3,y}$	1,5402e-04	m ³
Interpolated bending resistance	$M_{3,y,Rd}$	42,36	kNm
Unity check		0,06	-

Bending moment check for M_x

According to EN 1993-1-1 article 6.2.5 and formula (6.12),(6.13)

Interpolated section modulus	$W_{3,z}$	9,7393e-05	m ³
Interpolated bending resistance	$M_{3,z,Rd}$	26,78	kNm
Unity check		0,05	-

Shear check for V_y

According to EN 1993-1-1 article 6.2.6 and formula (6.17)

Shear correction factor	η	1,20	
Shear area	A_v	9,4143e-04	m ²
Plastic shear resistance for V_y	$V_{pl,y,Rd}$	149,47	kN
Unity check		0,01	-

Shear check for V_z

According to EN 1993-1-1 article 6.2.6 and formula (6.17)

Shear correction factor	η	1,20	
Shear area	A_v	1,6946e-03	m ²
Plastic shear resistance for V_z	$V_{pl,z,Rd}$	269,05	kN
Unity check		0,01	-

Torsion check

According to EN 1993-1-1 article 6.2.7 and formula (6.23)

Index of fibre	Fibre	1	
Total torsional moment	T_{Ed}	2,1	MPa
Elastic shear resistance	T_{Ed}	158,8	MPa
Unity check		0,01	-

Note: The unity check for torsion is lower than the limit value of 0,05. Therefore torsion is considered as insignificant and is ignored in the combined checks.

Combined bending, axial force and shear force check

According to EN 1993-1-1 article 6.2.9.1 and formula (6.41)

Interpolated moment resistance reduced due to N_{Ed}	$M_{N,3,y,Rd}$	22,98	kNm
Exponent of bending ratio y	α	2,17	
Interpolated moment resistance reduced due to N_{Ed}	$M_{N,3,z,Rd}$	14,53	kNm
Exponent of bending ratio z	β	2,17	

Unity check (6.41) = 0,01 + 0,01 = 0,02 -

Note: Since the shear forces are less than half the plastic shear resistances their effect on the moment resistances is neglected.

The member satisfies the section check.

....:STABILITY CHECK:....

Classification for member buckling design

Decisive position for stability classification: 0,000 m

Classification according to EN 1993-1-1 article 5.5.2

Classification of Internal and Outstand parts according to EN 1993-1-1 Table 5.2 Sheet 1 & 2

Id	Type	c [mm]	t [mm]	σ_1 [kN/m ²]	σ_2 [kN/m ²]	ψ [-]	k_σ [-]	α [-]	c/t [-]	Class 1 Limit [-]	Class 2 Limit [-]	Class 3 Limit [-]	Class
1	I	85	5	1,340e+05	1,602e+05	0,84		1,00	17,00	25,88	31,43	37,24	1
3	I	165	5	1,605e+05	1,205e+05	0,75		1,00	33,00	25,88	31,43	38,45	3
5	I	85	5	1,177e+05	9,155e+04	0,78		1,00	17,00	25,88	31,43	38,07	1
7	I	165	5	9,122e+04	1,312e+05	0,70		1,00	33,00	25,88	31,43	39,28	3

Note: The Classification limits have been set according to Semi-Comp+.

The cross-section is classified as Class 3

Flexural Buckling check

According to EN 1993-1-1 article 6.3.1.1 and formula (6.46)

Buckling parameters		yy	zz	
Sway type		sway	non-sway	
System length	L	2,459	2,459	m
Buckling factor	k	1,98	0,91	
Buckling length	l_{cr}	4,874	2,246	m
Critical Euler load	N_{cr}	980,65	1856,30	kN
Slenderness	λ	74,64	54,25	
Relative slenderness	λ_{rel}	0,85	0,62	
Limit slenderness	$\lambda_{rel,0}$	0,20	0,20	
Buckling curve	c	c	c	
Imperfection	α	0,49	0,49	

Buckling parameters		yy	zz
Reduction factor	χ	0,62	0,77
Buckling resistance	$N_{b,Rd}$	452,87	558,55

Flexural Buckling verification			
Cross-section area	A	2,6360e-03	m ²
Buckling resistance	$N_{b,Rd}$	452,87	kN
Unity check		0,73	-

Torsional(-Flexural) Buckling check

According to EN 1993-1-1 article 6.3.1.1 and formula (6.46)

Note: The cross-section concerns a RHS section which is not susceptible to Torsional(-Flexural) Buckling.

Lateral Torsional Buckling check

According to EN 1993-1-1 article 6.3.2.1

Note: The cross-section concerns an RHS section with $t_f / b < 10 / \lambda_{rel,z}$.

This section is thus not susceptible to Lateral Torsional Buckling.

Bending and axial compression check

According to EN 1993-1-1 article 6.3.3 and formula (6.61),(6.62)

Bending and axial compression check parameters			
Interaction method		alternative method 1	
Cross-section area	A	2,6360e-03	m ²
Interpolated section modulus	$W_{pl,y}$	1,5402e-04	m ³
Interpolated section modulus	$W_{pl,z}$	9,7393e-05	m ³
Design compression force	N_{Ed}	331,66	kN
Design bending moment (maximum)	$M_{y,Ed}$	-2,73	kNm
Design bending moment (maximum)	$M_{z,Ed}$	1,39	kNm
Characteristic compression resistance	N_{k1}	724,90	kN
Characteristic moment resistance	$M_{y,Rk}$	42,36	kNm
Characteristic moment resistance	$M_{z,Rk}$	26,78	kNm
Reduction factor	χ_y	0,62	
Reduction factor	χ_z	0,77	
Reduction factor	χ_{LT}	1,00	
Interaction factor	k_{yy}	0,99	
Interaction factor	k_{yz}	0,61	
Interaction factor	k_{zy}	0,81	
Interaction factor	k_{zz}	1,06	

Maximum moment $M_{y,Ed}$ is derived from beam B184 position 0,000 m.

Maximum moment $M_{z,Ed}$ is derived from beam B184 position 0,000 m.

Interaction method 1 parameters			
Critical Euler load	$N_{cr,y}$	980,65	kN
Critical Euler load	$N_{cr,z}$	1856,30	kN
Elastic critical load	$N_{cr,T}$	142231,02	kN
Interpolated section modulus	$W_{pl,y}$	1,5402e-04	m ³
Elastic section modulus	$W_{el,y}$	1,2491e-04	m ³
Interpolated section modulus	$W_{pl,z}$	9,7393e-05	m ³
Elastic section modulus	$W_{el,z}$	9,0350e-05	m ³
Second moment of area	I_y	1,1242e-05	m ⁴
Second moment of area	I_z	4,5177e-06	m ⁴
Torsional constant	I_t	1,0448e-05	m ⁴
Method for equivalent moment factor $C_{my,0}$		Table A.2 Line 2 (General)	
Design bending moment (maximum)	$M_{y,Ed}$	-2,73	kNm
Maximum relative deflection	δ_z	0,3	mm
Equivalent moment factor	$C_{my,2}$	0,83	
Method for equivalent moment factor $C_{mz,0}$		Table A.2 Line 2 (General)	
Design bending moment (maximum)	$M_{z,Ed}$	1,39	kNm
Maximum relative deflection	δ_y	-0,5	mm
Equivalent moment factor	$C_{mz,0}$	0,91	
Factor	μ_1	0,84	
Factor	μ_2	0,95	
Factor	ϵ_1	0,17	
Factor	$\delta_{1,T}$	0,07	
Critical moment for uniform bending	$M_{cr,0}$	1147,62	kNm
Relative slenderness	$\lambda_{rel,0}$	0,19	
Limit relative slenderness	$\lambda_{rel,lim}$	0,28	
Equivalent moment factor	C_{my}	0,83	
Equivalent moment factor	C_{mz}	0,91	
Equivalent moment factor	$C_{m1,T}$	1,00	
Factor	$b_{1,T}$	0,00	

Interaction method 1 parameters		
Factor	$c_{1,T}$	0,00
Factor	$d_{1,T}$	0,00
Factor	$e_{1,T}$	0,01
Factor	w_y	1,23
Factor	w_z	1,08
Factor	η_{pl}	0,46
Maximum relative slenderness	$\lambda_{rel,max}$	0,86
Factor	C_{y1}	1,06
Factor	C_{y2}	0,86
Factor	C_{y3}	0,95
Factor	C_{z2}	1,00

Unity check (6.61) = 0,73 + 0,06 + 0,03 = 0,83 -

Unity check (6.62) = 0,59 + 0,05 + 0,06 = 0,70 -

The member satisfies the stability check.

4.1.3. Vertikale

Vertikale se sastoje od dva poprečna presjeka. Dimenzije vertikala u prvom polju su 100x100x5 (mm) dok su na ostalim dijelovima odabrani profili dimenzija 90x90x5 (mm).

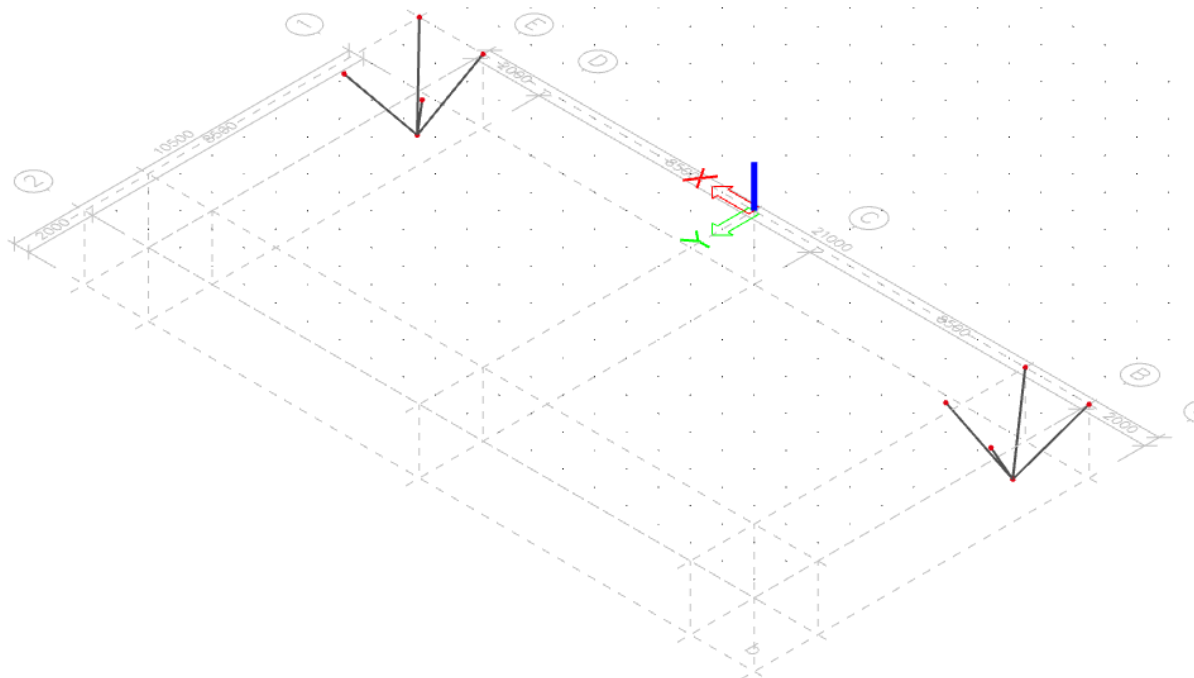

Slika 3.1.3.1. Prikaz položaja poprečnog presjeka

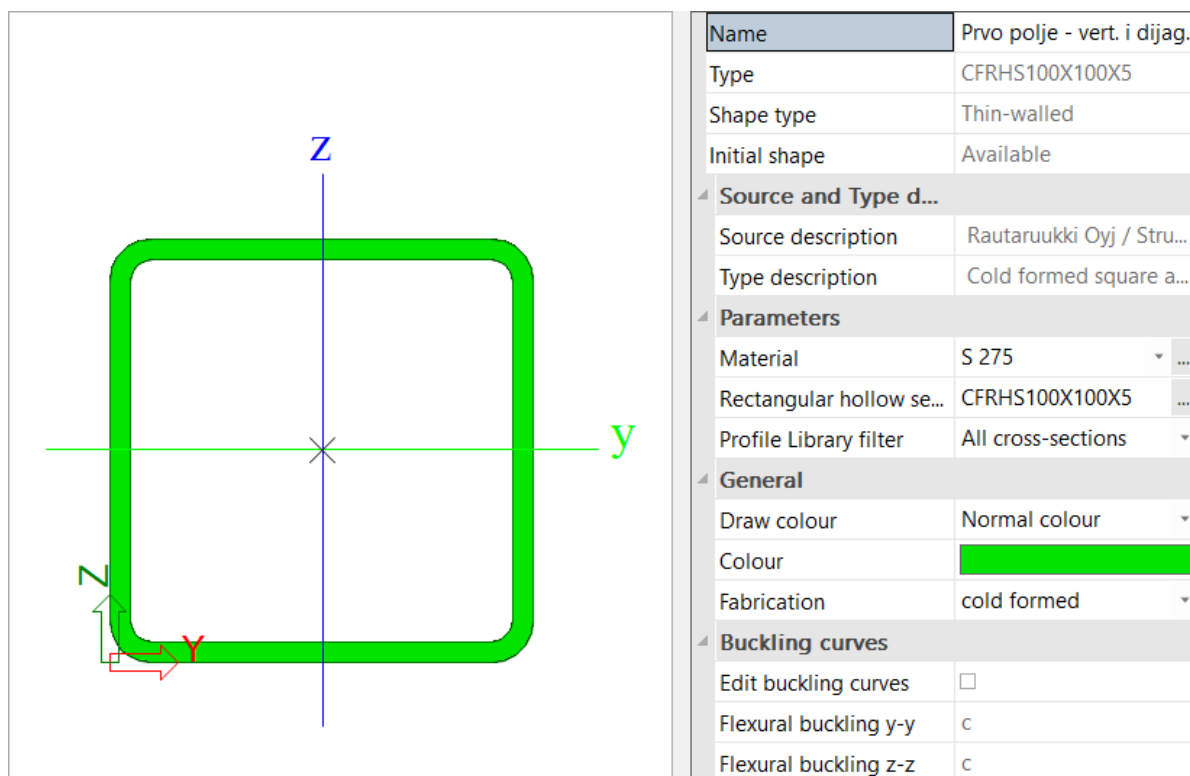

Slika 3.1.3.2. Poprečni presjek vertikala na prvim poljima

EC-EN 1993 Steel check ULS

Linear calculation

Combination: 1.

Coordinate system: Principal

Extreme 1D: Global

Selection: B105..B108, B159..B162

EN 1993-1-1 Code Check

National annex: Standard EN

Member B108 2,493 / 2,493 m CFRHS100X100X5 S 275 1. 0,95 -

Note: EN 1993-1-3 article 1.1(3) specifies that this part does not apply to cold formed CHS and RHS sections. The default EN 1993-1-1 code check is executed instead of the EN 1993-1-3 code check.

Combination key

1. / 1.35*Vlastita težina + 1.50*srijeg + 0.30*vjetar + 0.60*temperatura -

Partial safety factors

γ_{M0} for resistance of cross-sections	1,00
γ_{M1} for resistance to instability	1,00
γ_{M2} for resistance of net sections	1,25

Material

Yield strength	f_y	275,0	MPa
Ultimate strength	f_u	430,0	MPa
Fabrication		Cold formed	

...:SECTION CHECK:...

The critical check is on position 2,493 m

Internal forces		Calculated	Unit
Normal force	N_{Ed}	-275,52	kN
Shear force	$V_{y,Ed}$	2,04	kN
Shear force	$V_{z,Ed}$	0,57	kN
Torsion	T_{Ed}	0,47	kNm
Bending moment	$M_{y,Ed}$	0,14	kNm
Bending moment	$M_{z,Ed}$	3,27	kNm

Classification for cross-section design

Classification: according to EN 1993-1-1 article 5.5.2

Classification of Internal and Outstand parts according to EN 1993-1-1 Table 5.2 Sheet 1 & 2

Id	Type	c [mm]	t [mm]	σ_1 [kN/m ²]	σ_2 [kN/m ²]	ψ [-]	k_{σ} [-]	α [-]	c/t [-]	Class 1 Limit [-]	Class 2 Limit [-]	Class 3 Limit [-]	Class
1	I	85	5	9,640e+04	1,990e+05	0,48	1,00	17,00	25,88	31,43	42,78	1	
3	I	85	5	2,052e+05	2,096e+05	0,98	1,00	17,00	25,88	31,43	35,38	1	
5	I	85	5	2,038e+05	1,013e+05	0,50	1,00	17,00	25,88	31,43	42,56	1	
7	I	85	5	9,499e+04	9,062e+04	0,95	1,00	17,00	25,88	31,43	35,70	1	

Note: The Classification limits have been set according to Semi-Comp+. The cross-section is classified as Class 1

Compression check

According to EN 1993-1-1 article 6.2.4 and formula (6.9)

Cross-section area	A	1,8360e-03	m ²
Compression resistance	$N_{c,Rd}$	504,90	kN
Unity check		0,55	-

Bending moment check for M_y

According to EN 1993-1-1 article 6.2.5 and formula (6.12),(6.13)

Plastic section modulus	$W_{pl,y}$	6,4590e-05	m ³
Plastic bending moment	$M_{pl,y,Rd}$	17,76	kNm
Unity check		0,01	-

Bending moment check for M_z

According to EN 1993-1-1 article 6.2.5 and formula (6.12),(6.13)

Plastic section modulus	$W_{pl,z}$	6,4590e-05	m ³
Plastic bending moment	$M_{pl,z,Rd}$	17,76	kNm
Unity check		0,18	-

Shear check for V_y

According to EN 1993-1-1 article 6.2.6 and formula (6.17)

Shear correction factor	η	1,20	
Shear area	A_v	9,1800e-04	m ²
Plastic shear resistance for V_y	$V_{pl,y,Rd}$	145,75	kN
Unity check		0,01	-

Shear check for V_z

According to EN 1993-1-1 article 6.2.6 and formula (6.17)

Shear correction factor	η	1,20	
Shear area	A_v	9,1800e-04	m ²
Plastic shear resistance for V_z	$V_{pl,Rd}$	145,75	kN
Unity check		0,00	-

Torsion check

According to EN 1993-1-1 article 6.2.7 and formula (6.23)

Index of fibre	Fibre	1	
Total torsional moment	T_{Ed}	5,3	MPa
Elastic shear resistance	T_{Rd}	158,8	MPa
Unity check		0,03	-

Note: The unity check for torsion is lower than the limit value of 0,05. Therefore torsion is considered as insignificant and is ignored in the combined checks.

Combined bending, axial force and shear force check

According to EN 1993-1-1 article 6.2.9.1 and formula (6.41)

Design plastic moment resistance reduced due to N_{Ed}	$M_{N1y,Rd}$	10,45	kNm
Exponent of bending ratio γ	α	2,50	
Design plastic moment resistance reduced due to N_{Ed}	$M_{N1z,Rd}$	10,45	kNm
Exponent of bending ratio z	β	2,50	

Unity check (6.41) = $0,00 + 0,05 = 0,05$ -

Note: Since the shear forces are less than half the plastic shear resistances their effect on the moment resistances is neglected.

The member satisfies the section check.

....**STABILITY CHECK**:....

Classification for member buckling design

Decisive position for stability classification: 2,493 m

Classification according to EN 1993-1-1 article 5.5.2

Classification of [Internal and Outstand parts according to EN 1993-1-1 Table 5.2 Sheet 1 & 2

Id	Type	c [mm]	t [mm]	σ_1 [kN/m ²]	σ_2 [kN/m ²]	ψ [-]	k_{ψ} [-]	α [-]	c/t [-]	Class 1 Limit [-]	Class 2 Limit [-]	Class 3 Limit [-]	Class
1	I	85	5	9,640e+04	1,990e+05	0,48	1,00	17,00	25,88	31,43	42,78	1	
3	I	85	5	2,052e+05	2,096e+05	0,98	1,00	17,00	25,88	31,43	35,38	1	
5	I	85	5	2,038e+05	1,013e+05	0,50	1,00	17,00	25,88	31,43	42,56	1	
7	I	85	5	9,499e+04	9,062e+04	0,95	1,00	17,00	25,88	31,43	35,70	1	

Note: The Classification limits have been set according to Semi-Comp+.

The cross-section is classified as Class 1

Flexural Buckling check

According to EN 1993-1-1 article 6.3.1.1 and formula (6.46)

Buckling parameters		yy	zz	
Sway type		sway	non-sway	
System length	l	2,493	2,493	m
Buckling factor	k	1,00	0,74	
Buckling length	l_{cr}	2,493	1,835	m
Critical Euler load	N_{cr}	904,24	1668,70	kN
Slenderness	λ	64,87	47,75	
Relative slenderness	λ_{rel}	0,75	0,55	
Limit slenderness	λ_{rel0}	0,20	0,20	
Buckling curve		c	c	
Imperfection	α	0,49	0,49	
Reduction factor	χ	0,70	0,81	
Buckling resistance	$N_{b,Rd}$	351,04	411,28	kN

Flexural Buckling verification

Cross-section area	A	1,8360e-03	m ²
Buckling resistance	$N_{b,Rd}$	351,04	kN
Unity check		0,78	-

Torsional(-Flexural) Buckling check

According to EN 1993-1-1 article 6.3.1.1 and formula (6.46)

Note: The cross-section concerns a RHS section which is not susceptible to Torsional(-Flexural) Buckling.

Lateral Torsional Buckling check

According to EN 1993-1-1 article 6.3.2.1

Note: The cross-section concerns an RHS section with $t_h / b < 10 / \lambda_{rel,z}^2$. This section is thus not susceptible to Lateral Torsional Buckling.

Bending and axial compression check

According to EN 1993-1-1 article 6.3.3 and formula (6.61),(6.62)

Bending and axial compression check parameters			
Interaction method		alternative method 1	
Cross-section area	A	1,8360e-03	m ²
Plastic section modulus	W _{pl,y}	6,4590e-05	m ³
Plastic section modulus	W _{pl,z}	6,4590e-05	m ³
Design compression force	N _{Ed}	275,52	kN
Design bending moment (maximum)	M _{y,Ed}	-1,64	kNm
Design bending moment (maximum)	M _{z,Ed}	3,27	kNm
Characteristic compression resistance	N _{sk}	504,90	kN
Characteristic moment resistance	M _{y,Rk}	17,76	kNm
Characteristic moment resistance	M _{z,Rk}	17,76	kNm
Reduction factor	χ _y	0,70	
Reduction factor	χ _z	0,81	
Reduction factor	χ _{LT}	1,00	
Interaction factor	k _{yy}	1,01	
Interaction factor	k _{yz}	0,37	
Interaction factor	k _{zy}	0,74	
Interaction factor	k _{zz}	0,63	

Maximum moment M_{y,Ed} is derived from beam B108 position 0,000 m.Maximum moment M_{z,Ed} is derived from beam B108 position 2,493 m.

Interaction method 1 parameters			
Critical Euler load	N _{cr,y}	904,24	kN
Critical Euler load	N _{cr,z}	1668,70	kN
Elastic critical load	N _{cr,T}	120953,32	kN
Plastic section modulus	W _{pl,y}	6,4590e-05	m ³
Elastic section modulus	W _{el,y}	5,4220e-05	m ³
Plastic section modulus	W _{pl,z}	6,4590e-05	m ³
Elastic section modulus	W _{el,z}	5,4220e-05	m ³
Second moment of area	I _y	2,7110e-06	m ⁴
Second moment of area	I _z	2,7110e-06	m ⁴
Torsional constant	I _t	4,4052e-06	m ⁴
Method for equivalent moment factor C _{my,0}		Table A.2 Line 2 (General)	
Design bending moment (maximum)	M _{y,Ed}	-1,64	kNm
Maximum relative deflection	δ _c	1,0	mm
Equivalent moment factor	C _{my,0}	0,86	
Method for equivalent moment factor C _{mz,0}		Table A.2 Line 1 (Linear)	
Ratio of end moments	ψ _z	-0,56	
Equivalent moment factor	C _{mz,0}	0,62	
Factor	μ _y	0,88	
Factor	μ _z	0,96	
Factor	ε ₁	0,20	
Factor	ε ₂	0,00	
Critical moment for uniform bending	M _{cr,0}	568,32	kNm
Relative slenderness	λ _{rel,0}	0,18	
Limit relative slenderness	λ _{rel,0,lim}	0,27	
Equivalent moment factor	C _{my}	0,86	
Equivalent moment factor	C _{mz}	0,62	
Equivalent moment factor	C _{mLT}	1,00	
Factor	b _{LT}	0,00	
Factor	c _{LT}	0,00	
Factor	d _{LT}	0,00	
Factor	e _{LT}	0,00	
Factor	w _y	1,19	
Factor	w _z	1,19	
Factor	η _{pl}	0,55	
Maximum relative slenderness	λ _{rel,max}	0,75	
Factor	C ₀₁	1,07	
Factor	C ₀₂	1,08	
Factor	C _{0y}	0,96	
Factor	C _{0z}	1,14	

Unity check (6.61) = 0,78 + 0,09 + 0,07 = 0,95 -

Unity check (6.62) = 0,67 + 0,07 + 0,12 = 0,85 -

The member satisfies the stability check.

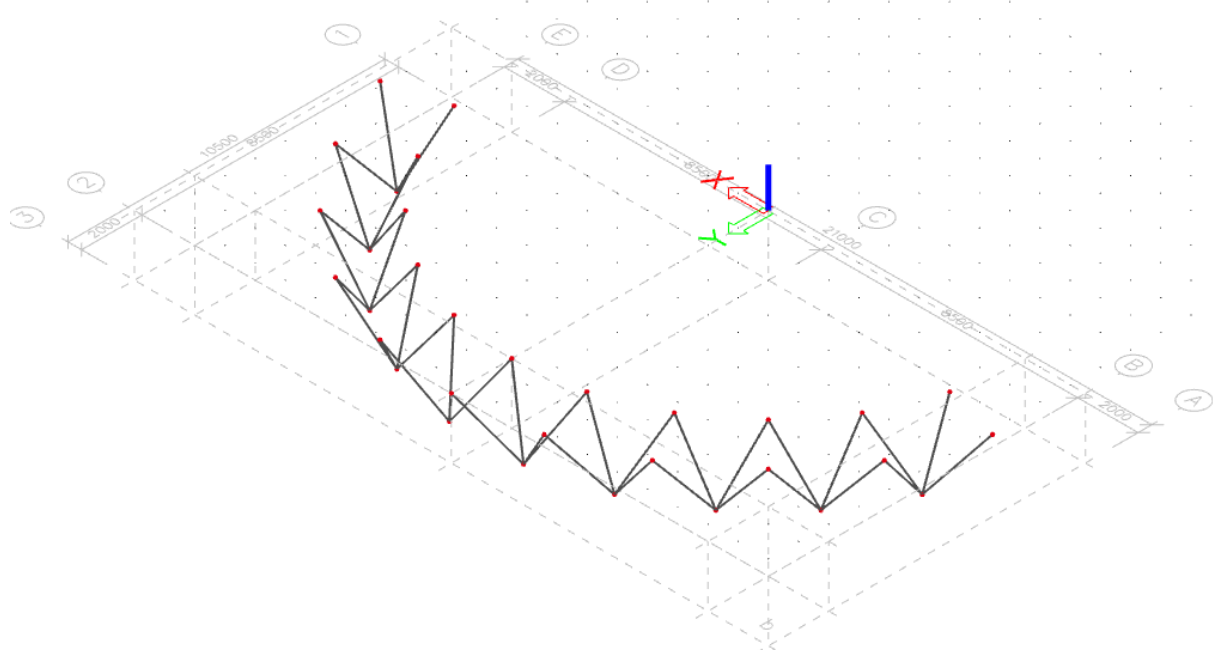

Slika 3.1.3.3. Prikaz položaja poprečnog presjeka

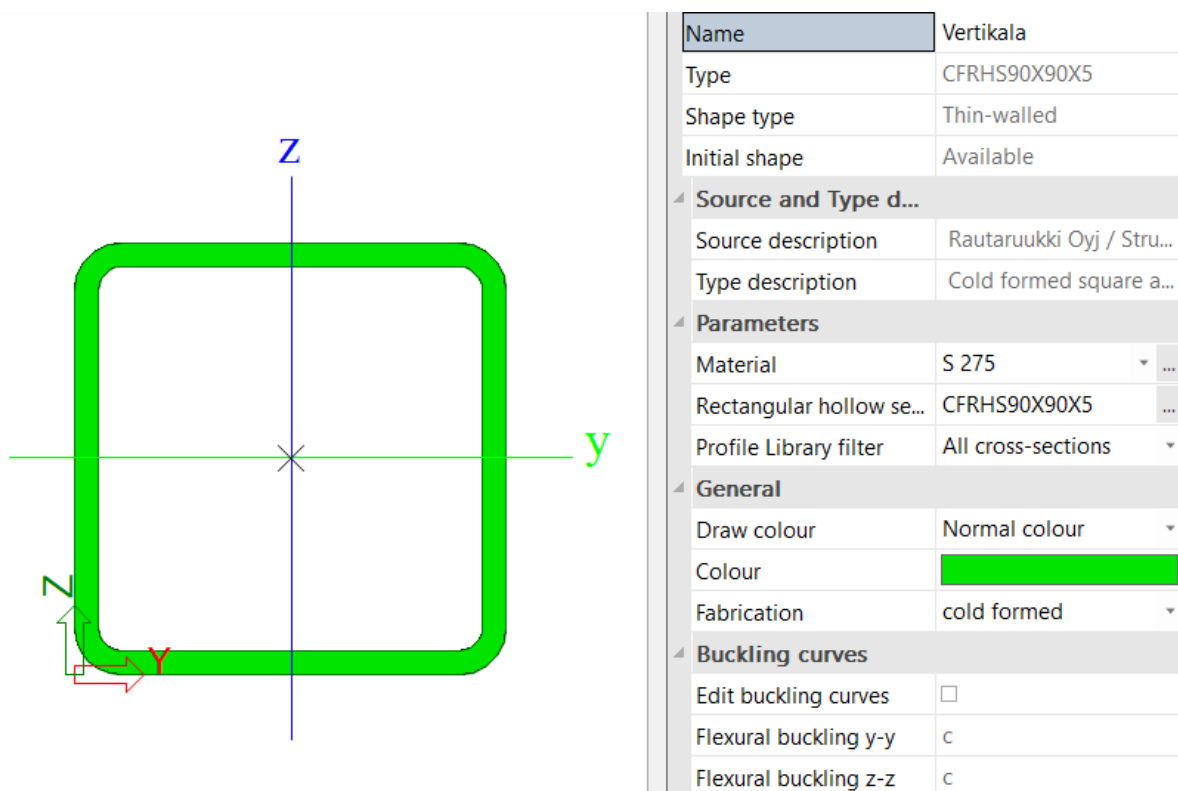

Slika 3.1.3.4. Poprečni presjek vertikala na ostalim poljima

EC-EN 1993 Steel check ULS

Linear calculation

Combination: 1.

Coordinate system: Principal

Extreme 1D: Global

Selection: B109..B126, B128, B129, B163..B182

EN 1993-1-1 Code Check

National annex: Standard EN

Member B115 | **0,000 / 2,619 m** | **CFRHS90X90X5** | **S 275** | **1.** | **0,84 -**

Note: EN 1993-1-3 article 1.1(3) specifies that this part does not apply to cold formed CHS and RHS sections. The default EN 1993-1-1 code check is executed instead of the EN 1993-1-3 code check.

Combination key

1. / 1.35*Vlastita težina + 1.50*srijeg + 0.30*vjetar + 0.60*temperatura -

Partial safety factors

γ_{M0} for resistance of cross-sections	1,00
γ_{M1} for resistance to instability	1,00
γ_{M2} for resistance of net sections	1,25

Material

Yield strength	f_y	275,0	MPa
Ultimate strength	f_u	430,0	MPa
Fabrication		Cold formed	

....SECTION CHECK:....**The critical check is on position 0,000 m**

Internal forces	Calculated	Unit
Normal force	N_{Ed}	-204,07 kN
Shear force	$V_{y,Ed}$	-0,42 kN
Shear force	$V_{z,Ed}$	0,13 kN
Torsion	T_{Ed}	-0,18 kNm
Bending moment	$M_{y,Ed}$	-0,01 kNm
Bending moment	$M_{z,Ed}$	0,62 kNm

Classification for cross-section design

Classification: according to EN 1993-1-1 article 5.5.2

Classification of Internal and Outstand parts according to EN 1993-1-1 Table 5.2 Sheet 1 & 2

Id	Type	c [mm]	t [mm]	σ_1 [kN/m ²]	σ_2 [kN/m ²]	ψ [-]	k_{σ} [-]	α [-]	c/t [-]	Class 1 Limit [-]	Class 2 Limit [-]	Class 3 Limit [-]	Class
1	I	75	5	1,130e+05	1,372e+05	0,82		1,00	15,00	25,88	31,43	37,42	1
3	I	75	5	1,388e+05	1,382e+05	1,00		1,00	15,00	25,88	31,43	35,18	1
5	I	75	5	1,366e+05	1,123e+05	0,82		1,00	15,00	25,88	31,43	37,43	1
7	I	75	5	1,108e+05	1,113e+05	0,99		1,00	15,00	25,88	31,43	35,19	1

Note: The Classification limits have been set according to Semi-Comp+. The cross-section is classified as Class 1

Compression check

According to EN 1993-1-1 article 6.2.4 and formula (6.9)

Cross-section area	A	1,6360e-03	m ²
Compression resistance	$N_{c,Rd}$	449,90	kN
Unity check		0,45	-

Bending moment check for M_y

According to EN 1993-1-1 article 6.2.5 and formula (6.12),(6.13)

Plastic section modulus	$W_{pl,y}$	5,1410e-05	m ³
Plastic bending moment	$M_{pl,y,Rd}$	14,14	kNm
Unity check		0,00	-

Bending moment check for M_z

According to EN 1993-1-1 article 6.2.5 and formula (6.12),(6.13)

Plastic section modulus	$W_{pl,z}$	5,1410e-05	m ³
Plastic bending moment	$M_{pl,z,Rd}$	14,14	kNm
Unity check		0,04	-

Shear check for V_y

According to EN 1993-1-1 article 6.2.6 and formula (6.17)

Shear correction factor	η	1,20	
Shear area	A_v	8,1800e-04	m ²
Plastic shear resistance for V_y	$V_{pl,y,Rd}$	129,67	kN
Unity check		0,00	-

Shear check for V_x

According to EN 1993-1-1 article 6.2.6 and formula (6.17)

Shear correction factor	η	1,20	
Shear area	A_v	8,1890e-04	m ²
Plastic shear resistance for V_x	$V_{pl,x,Rd}$	129,87	kN
Unity check		0,00	-

Torsion check

According to EN 1993-1-1 article 6.2.7 and formula (6.23)

Index of fibre	Fibre	1	
Total torsional moment	T_{Ed}	2,5	MPa
Elastic shear resistance	T_{Rd}	158,8	MPa
Unity check		0,02	-

Note: The unity check for torsion is lower than the limit value of 0,05. Therefore torsion is considered as insignificant and is ignored in the combined checks.

Combined bending, axial force and shear force check

According to EN 1993-1-1 article 6.2.9.1 and formula (6.41)

Design plastic moment resistance reduced due to N_{Ed}	$M_{N,y,Rd}$	9,97	kNm
Exponent of bending ratio y	α	2,16	
Design plastic moment resistance reduced due to N_{Ed}	$M_{N,z,Rd}$	9,97	kNm
Exponent of bending ratio z	β	2,16	

Unity check (6.41) = 0,00 + 0,00 = 0,00 -

Note: Since the shear forces are less than half the plastic shear resistances their effect on the moment resistances is neglected.

The member satisfies the section check.

....:STABILITY CHECK:....

Classification for member buckling design

Decisive position for stability classification: 0,000 m

Classification according to EN 1993-1-1 article 5.5.2

Classification of Internal and Outstand parts according to EN 1993-1-1 Table 5.2 Sheet 1 & 2

Id	Type	c [mm]	t [mm]	σ_1 [kN/m ²]	σ_2 [kN/m ²]	ψ [-]	k_σ [-]	α [-]	c/t [-]	Class 1 Limit [-]	Class 2 Limit [-]	Class 3 Limit [-]	Class
1	I	75	5	1,130e+05	1,372e+05	0,82	1,00	15,00	25,88	31,43	37,42	1	
3	I	75	5	1,388e+05	1,382e+05	1,00	1,00	15,00	25,88	31,43	35,18	1	
5	I	75	5	1,366e+05	1,123e+05	0,82	1,00	15,00	25,88	31,43	37,43	1	
7	I	75	5	1,108e+05	1,113e+05	0,99	1,00	15,00	25,88	31,43	35,19	1	

Note: The Classification limits have been set according to Semi-Comp+.

The cross-section is classified as Class 1

Flexural Buckling check

According to EN 1993-1-1 article 6.3.1.1 and formula (6.46)

Buckling parameters		yy	zz	
Sway type		sway	non-sway	
System length	L	2,619	2,619	m
Buckling factor	k	1,11	0,56	
Buckling length	l_{cr}	2,918	1,465	m
Critical Euler load	N_{cr}	469,48	1864,19	kN
Slenderness	λ	84,99	42,65	
Relative slenderness	λ_{rel}	0,98	0,49	
Limit slenderness	$\lambda_{rel,0}$	0,20	0,20	
Buckling curve	c	c	c	
Imperfection	α	0,49	0,49	
Reduction factor	χ	0,55	0,85	
Buckling resistance	$N_{b,Rd}$	248,46	381,45	kN

Flexural Buckling verification

Cross-section area	A	1,6360e-03	m ²
Buckling resistance	$N_{b,Rd}$	248,46	kN
Unity check		0,82	-

Torsional(-Flexural) Buckling check

According to EN 1993-1-1 article 6.3.1.1 and formula (6.46)

Note: The cross-section concerns a RHS section which is not susceptible to Torsional(-Flexural) Buckling.

Lateral Torsional Buckling check

According to EN 1993-1-1 article 6.3.2.1

Note: The cross-section concerns an RHS section with $h/b < 10 / \lambda_{rel,z}^2$. This section is thus not susceptible to Lateral Torsional Buckling.

Bending and axial compression check

According to EN 1993-1-1 article 6.3.3 and formula (6.61)/(6.62)

Bending and axial compression check parameters			
Interaction method		alternative method 1	
Cross-section area	A	1,6360e-03	m ²
Plastic section modulus	$W_{pl,y}$	5,1410e-05	m ³
Plastic section modulus	$W_{pl,z}$	5,1410e-05	m ³
Design compression force	N_{Ed}	204,07	kN
Design bending moment (maximum)	$M_{y,Ed}$	0,06	kNm
Design bending moment (maximum)	$M_{z,Ed}$	0,62	kNm
Characteristic compression resistance	N_{Rk}	449,90	kN
Characteristic moment resistance	$M_{y,Rk}$	14,14	kNm
Characteristic moment resistance	$M_{z,Rk}$	14,14	kNm
Reduction factor	χ_y	0,55	
Reduction factor	χ_z	0,85	
Reduction factor	χ_{LT}	1,00	
Interaction factor	k_{yy}	1,32	
Interaction factor	k_{yz}	0,29	
Interaction factor	k_{zy}	1,39	
Interaction factor	k_{zz}	0,59	

Maximum moment $M_{y,Ed}$ is derived from beam B115 position 1,091 m.Maximum moment $M_{z,Ed}$ is derived from beam B115 position 0,000 m.

Interaction method 1 parameters			
Critical Euler load	$N_{cr,y}$	469,48	kN
Critical Euler load	$N_{cr,z}$	1864,19	kN
Elastic critical load	$N_{cr,T}$	108618,93	kN
Plastic section modulus	$W_{pl,y}$	5,1410e-05	m ³
Elastic section modulus	$W_{el,y}$	4,2870e-05	m ³
Plastic section modulus	$W_{pl,z}$	5,1410e-05	m ³
Elastic section modulus	$W_{el,z}$	4,2870e-05	m ³
Second moment of area	I_y	1,9293e-06	m ⁴
Second moment of area	I_z	1,9293e-06	m ⁴
Torsional constant	I_t	3,1626e-06	m ⁴
Method for equivalent moment factor $C_{my,0}$		Table A.2 Line 2 (General)	
Design bending moment (maximum)	$M_{y,Ed}$	0,06	kNm
Maximum relative deflection	δ_z	-0,1	mm
Equivalent moment factor	$C_{my,0}$	0,97	
Method for equivalent moment factor $C_{mz,0}$		Table A.2 Line 1 (Linear)	
Ratio of end moments	ψ_z	-0,75	
Equivalent moment factor	$C_{mz,0}$	0,59	
Factor	μ_z	0,74	
Factor	μ_z	0,98	
Factor	ϵ_y	0,01	
Factor	$\alpha_{1,T}$	0,00	
Critical moment for uniform bending	$M_{cr,0}$	386,40	kNm
Relative slenderness	$\lambda_{rel,0}$	0,19	
Limit relative slenderness	$\lambda_{rel,0,lim}$	0,21	
Equivalent moment factor	C_{my}	0,97	
Equivalent moment factor	C_{mz}	0,59	
Equivalent moment factor	C_{mLT}	1,00	
Factor	$b_{1,T}$	0,00	
Factor	$c_{1,T}$	0,00	
Factor	$d_{1,T}$	0,00	
Factor	$e_{1,T}$	0,00	
Factor	w_y	1,20	
Factor	w_z	1,20	
Factor	η_{pl}	0,45	
Maximum relative slenderness	$\lambda_{rel,max}$	0,98	
Factor	C_{yy}	0,96	
Factor	C_{yz}	1,01	
Factor	C_{zy}	0,72	
Factor	C_{zz}	1,10	

Unity check (6.61) = 0,82 + 0,01 + 0,01 = 0,84 -

Unity check (6.62) = 0,53 + 0,01 + 0,03 = 0,57 -

The member satisfies the stability check.

4.1.4. Dijagonale

Dijagonale se sastoje od dva poprečna presjeka. Dimenzije dijagonala u prvom polju su 100x100x5 (mm) dok su na ostalim poljima odabrani profili dimenzija 90x90x5 (mm).

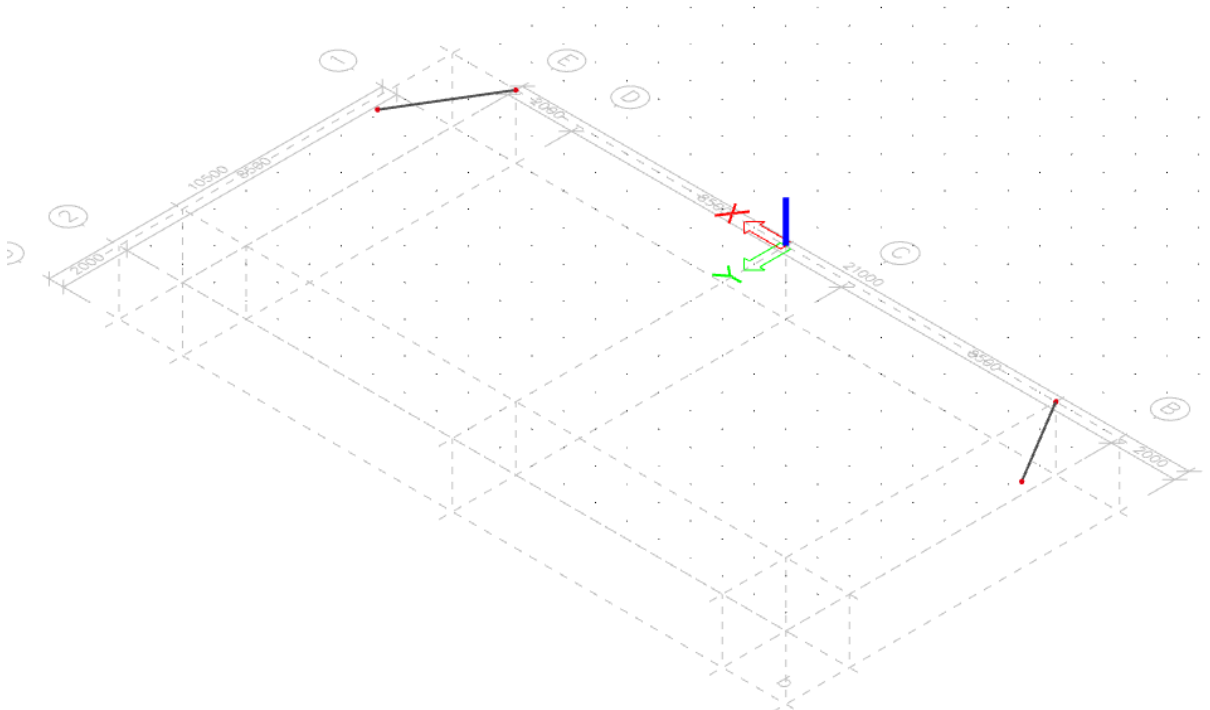

Slika 3.1.4.1. Prikaz položaja poprečnog presjeka

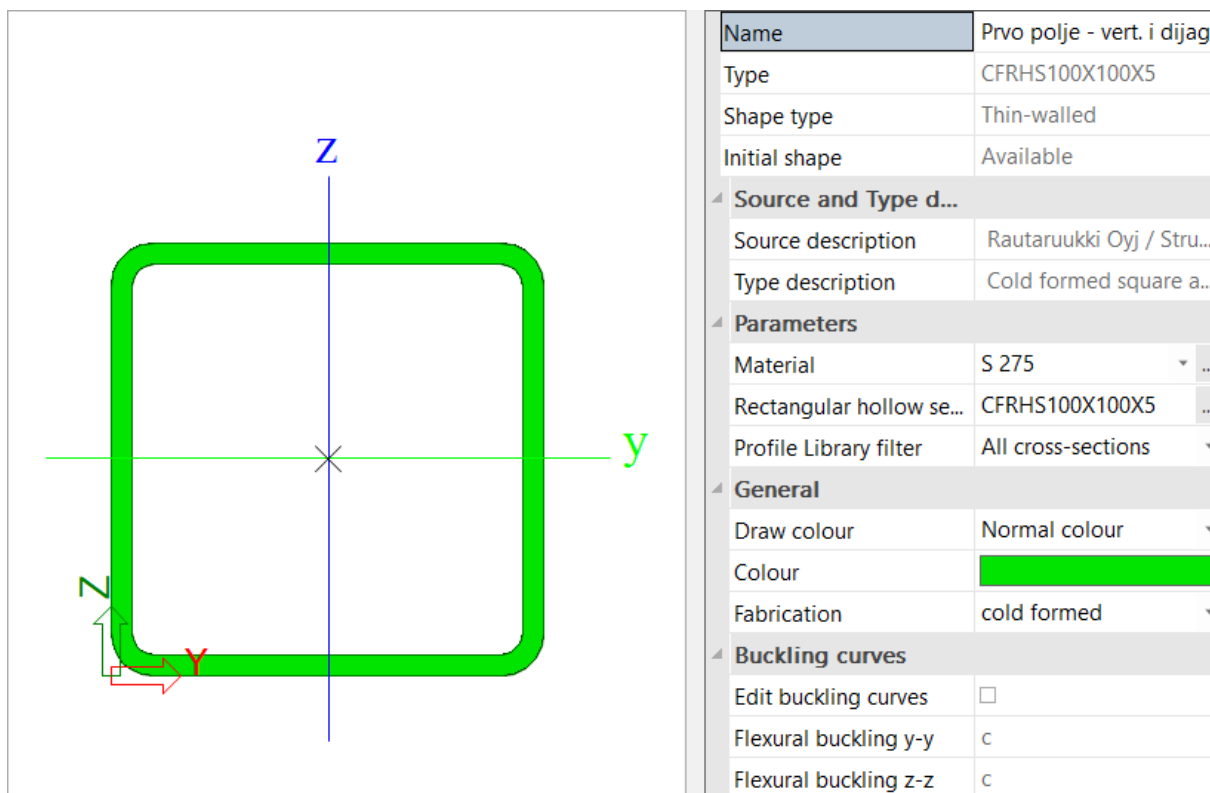

Slika 3.1.4.2. Poprečni presjek dijagonala na prvom poljima

EC-EN 1993 Steel check ULS

Linear calculation
 Combination: 2.
 Coordinate system: Principal
 Extreme 1D: Global
 Selection: B135, B180

EN 1993-1-1 Code Check
 National annex: Standard EN

Member B135	0,000 / 3,175 m	CFRHS100X100X5	S 275	2.	0,87 -
--------------------	------------------------	-----------------------	--------------	-----------	---------------

Note: EN 1993-1-3 article 1.1(3) specifies that this part does not apply to cold formed CHS and RHS sections. The default EN 1993-1-1 code check is executed instead of the EN 1993-1-3 code check.

Combination key	
2. / 1.35*Vlastita težina + 0.30*vjetar + 0.60*temperatura + + 1.50*pješaci	

Partial safety factors	
γ_{M0} for resistance of cross-sections	1,00
γ_{M1} for resistance to instability	1,00
γ_{M2} for resistance of net sections	1,25

Material			
Yield strength	f_y	275,0	MPa
Ultimate strength	f_u	430,0	MPa
Fabrication		Cold formed	

....SECTION CHECK:....

The critical check is on position 0,000 m

Internal forces		Calculated	Unit
Normal force	N_{Ed}	-180,92	kN
Shear force	$V_{y,Ed}$	0,68	kN
Shear force	$V_{z,Ed}$	1,33	kN
Torsion	T_{Ed}	-0,66	kNm
Bending moment	$M_{y,Ed}$	-1,32	kNm
Bending moment	$M_{z,Ed}$	-1,19	kNm

Classification for cross-section design

Classification: according to EN 1993-1-1 article 5.5.2
 Classification of Internal and Outstand parts according to EN 1993-1-1 Table 5.2 Sheet 1 & 2

Id	Type	c [mm]	t [mm]	σ_1 [kN/m ²]	σ_2 [kN/m ²]	ψ [-]	γ_{M0} [-]	α [-]	c/t [-]	Class 1 Limit [-]	Class 2 Limit [-]	Class 3 Limit [-]	Class
1	I	85	5	1,403e+05	1,031e+05	0,73		1,00	17,00	25,88	31,43	38,69	1
3	I	85	5	9,844e+04	5,713e+04	0,58		1,00	17,00	25,88	31,43	41,11	1
5	I	85	5	5,689e+04	9,410e+04	0,60		1,00	17,00	25,88	31,43	40,71	1
7	I	85	5	9,872e+04	1,400e+05	0,71		1,00	17,00	25,88	31,43	39,13	1

Note: The Classification limits have been set according to Semi-Comp+. The cross-section is classified as Class 1

Compression check

According to EN 1993-1-1 article 6.2.4 and formula (6.9)

Cross-section area	A	1,8360e-03	m ²
Compression resistance	$N_{c,Rd}$	504,90	kN
Unity check		0,36	-

Bending moment check for M_y

According to EN 1993-1-1 article 6.2.5 and formula (6.12),(6.13)

Plastic section modulus	$W_{pl,y}$	6,4590e-05	m ³
Plastic bending moment	$M_{pl,y,Rd}$	17,76	kNm
Unity check		0,07	-

Bending moment check for M_z

According to EN 1993-1-1 article 6.2.5 and formula (6.12),(6.13)

Plastic section modulus	$W_{pl,z}$	6,4590e-05	m ³
Plastic bending moment	$M_{pl,z,Rd}$	17,76	kNm
Unity check		0,07	-

Shear check for V_y

According to EN 1993-1-1 article 6.2.6 and formula (6.17)

Shear correction factor	η	1,20	
Shear area	A_v	9,1800e-04	m ²
Plastic shear resistance for V_y	$V_{pl,y,Rd}$	145,75	kN
Unity check		0,00	-

Shear check for V_d

According to EN 1993-1-1 article 6.2.6 and formula (6.17)

Shear correction factor	η	1,20	
Shear area	A_v	9,1800e-04	m ²
Plastic shear resistance for V_d	$V_{pl,Rd}$	145,75	kN
Unity check		0,01	-

Torsion check

According to EN 1993-1-1 article 6.2.7 and formula (6.23)

Index of fibre	Fibre	1	
Total torsional moment	T_{Ed}	7,3	MPa
Elastic shear resistance	T_{Rd}	158,8	MPa
Unity check		0,05	-

Note: The unity check for torsion is lower than the limit value of 0,05. Therefore torsion is considered as insignificant and is ignored in the combined checks.

Combined bending, axial force and shear force check

According to EN 1993-1-1 article 6.2.9.1 and formula (6.41)

Design plastic moment resistance reduced due to N_{Ed}	$M_{N,y,Rd}$	14,76	kNm
Exponent of bending ratio γ	α	1,94	
Design plastic moment resistance reduced due to N_{Ed}	$M_{N,z,Rd}$	14,76	kNm
Exponent of bending ratio z	β	1,94	

Unity check (6.41) = 0,01 + 0,01 = 0,02 -

Note: Since the shear forces are less than half the plastic shear resistances their effect on the moment resistances is neglected.

The member satisfies the section check.

...::STABILITY CHECK::...

Classification for member buckling design

Decisive position for stability classification: 3,175 m

Classification according to EN 1993-1-1 article 5.5.2

Classification of Internal and Outstand parts according to EN 1993-1-1 Table 5.2 Sheet 1 & 2

Id	Type	c [mm]	t [mm]	σ_1 [kN/m ²]	σ_2 [kN/m ²]	ψ [-]	k_{σ} [-]	α [-]	c/t [-]	Class 1 Limit [-]	Class 2 Limit [-]	Class 3 Limit [-]	Class
1	I	85	5	4,927e+04	7,942e+04	0,62	1,00	17,00	25,88	31,43	40,46	1	
3	I	85	5	8,480e+04	1,461e+05	0,58	1,00	17,00	25,88	31,43	41,11	1	
5	I	85	5	1,479e+05	1,177e+05	0,80	1,00	17,00	25,88	31,43	37,80	1	
7	I	85	5	1,124e+05	5,110e+04	0,45	1,00	17,00	25,88	31,43	43,32	1	

Note: The Classification limits have been set according to Semi-Comp+.
The cross-section is classified as Class 1

Flexural Buckling check

According to EN 1993-1-1 article 6.3.1.1 and formula (6.46)

Buckling parameters		yy	zz	
Sway type		sway	non-sway	
System length	L	3,175	3,175	m
Buckling factor	k	1,16	0,63	
Buckling length	l_{cr}	3,696	1,996	m
Critical Euler load	N_{cr}	411,22	1410,94	kN
Slenderness	λ	96,20	51,93	
Relative slenderness	λ_{rel}	1,11	0,60	
Limit slenderness	$\lambda_{rel,0}$	0,20	0,20	
Buckling curve		c	c	
Imperfection	α	0,49	0,49	
Reduction factor	χ	0,48	0,79	
Buckling resistance	$N_{b,Rd}$	242,34	397,08	kN

Flexural Buckling verification

Cross-section area	A	1,8360e-03	m ²
Buckling resistance	$N_{b,Rd}$	242,34	kN
Unity check		0,75	-

Torsional(-Flexural) Buckling check

According to EN 1993-1-1 article 6.3.1.1 and formula (6.46)

Note: The cross-section concerns a RHS section which is not susceptible to Torsional(-Flexural) Buckling.

Lateral Torsional Buckling check

According to EN 1993-1-1 article 6.3.2.1

Note: The cross-section concerns an RHS section with $h/b < 10 / \lambda_{rel,z}^2$.
This section is thus not susceptible to Lateral Torsional Buckling.

Bending and axial compression check

According to EN 1993-1-1 article 6.3.3 and formula (6.61),(6.62)

Bending and axial compression check parameters			
Interaction method		alternative method 1	
Cross-section area	A	1,8360e-03	m ²
Plastic section modulus	W _{pl,y}	6,4590e-05	m ³
Plastic section modulus	W _{pl,z}	6,4590e-05	m ³
Design compression force	N _{Ed}	180,92	kN
Design bending moment (maximum)	M _{y,Ed}	1,95	kNm
Design bending moment (maximum)	M _{z,Ed}	-1,19	kNm
Characteristic compression resistance	N _{sk}	504,90	kN
Characteristic moment resistance	M _{y,Rk}	17,76	kNm
Characteristic moment resistance	M _{z,Rk}	17,76	kNm
Reduction factor	χ _y	0,48	
Reduction factor	χ _z	0,79	
Reduction factor	χ _{LT}	1,00	
Interaction factor	k _{yy}	0,91	
Interaction factor	k _{yz}	0,28	
Interaction factor	k _{zy}	0,87	
Interaction factor	k _{ax}	0,59	

Maximum moment M_{y,Ed} is derived from beam B135 position 3,175 m.Maximum moment M_{z,Ed} is derived from beam B135 position 0,000 m.

Interaction method 1 parameters			
Critical Euler load	N _{cr,y}	411,22	kN
Critical Euler load	N _{cr,z}	1410,94	kN
Elastic critical load	N _{cr,T}	120772,76	kN
Plastic section modulus	W _{pl,y}	6,4590e-05	m ³
Elastic section modulus	W _{el,y}	5,4220e-05	m ³
Plastic section modulus	W _{pl,z}	6,4590e-05	m ³
Elastic section modulus	W _{el,z}	5,4220e-05	m ³
Second moment of area	I _y	2,7110e-06	m ⁴
Second moment of area	I _z	2,7110e-06	m ⁴
Torsional constant	I _t	4,4052e-06	m ⁴
Method for equivalent moment factor C _{my,0}		Table A.2 Line 2 (General)	
Design bending moment (maximum)	M _{y,Ed}	1,95	kNm
Maximum relative deflection	δ _c	-1,4	mm
Equivalent moment factor	C _{my,0}	0,73	
Method for equivalent moment factor C _{mz,0}		Table A.2 Line 1 (Linear)	
Ratio of end moments	ψ _z	-0,81	
Equivalent moment factor	C _{mz,0}	0,57	
Factor	μ _y	0,71	
Factor	μ _z	0,97	
Factor	ε _y	0,37	
Factor	α _{LT}	0,00	
Critical moment for uniform bending	M _{cr,0}	445,83	kNm
Relative slenderness	λ _{rel,0}	0,20	
Limit relative slenderness	λ _{rel,0,lim}	0,28	
Equivalent moment factor	C _{my}	0,73	
Equivalent moment factor	C _{mz}	0,57	
Equivalent moment factor	C _{mLT}	1,00	
Factor	b _{LT}	0,00	
Factor	c _{LT}	0,00	
Factor	d _{LT}	0,00	
Factor	e _{LT}	0,00	
Factor	w _y	1,19	
Factor	w _z	1,19	
Factor	η _{pl}	0,36	
Maximum relative slenderness	λ _{rel,max}	1,11	
Factor	C _{ys}	1,02	
Factor	C _{yz}	0,98	
Factor	C _{zy}	0,87	
Factor	C _{ax}	1,07	

Unity check (6.61) = 0,75 + 0,10 + 0,02 = 0,87 -

Unity check (6.62) = 0,46 + 0,10 + 0,04 = 0,59 -

The member satisfies the stability check.

EC-EN 1993 Steel check ULS

Linear calculation

Combination: 1.

Coordinate system: Principal

Extreme 1D: Global

Selection: B135, B188

EN 1993-1-1 Code Check

National annex: Standard EN

Member B135 0,000 / 3,175 m CFRHS100X100X5 S 275 1. 0,94 -

Note: EN 1993-1-3 article 1.1(3) specifies that this part does not apply to cold formed CHS and RHS sections.

The default EN 1993-1-1 code check is executed instead of the EN 1993-1-3 code check.

Combination key	
1. / 1.35*	Vlastita težina + 1.50*snijeg + 0.30*vjetar + 0.60*temperatura -

Partial safety factors	
γ_{M0} for resistance of cross-sections	1,00
γ_{M1} for resistance to instability	1,00
γ_{M2} for resistance of net sections	1,25

Material			
Yield strength	f_y	275,0	MPa
Ultimate strength	f_u	430,0	MPa
Fabrication		Cold formed	

....SECTION CHECK:....

The critical check is on position 0,000 m

Internal forces		Calculated	Unit
Normal force	N_{Ed}	-197,65	kN
Shear force	$V_{y,Ed}$	0,75	kN
Shear force	$V_{z,Ed}$	1,43	kN
Torsion	T_{Ed}	-0,72	kNm
Bending moment	$M_{y,Ed}$	-1,42	kNm
Bending moment	$M_{z,Ed}$	-1,30	kNm

Classification for cross-section design

Classification: according to EN 1993-1-1 article 5.5.2

Classification of Internal and Outstand parts according to EN 1993-1-1 Table 5.2 Sheet 1 & 2

Id	Type	c [mm]	t [mm]	σ_1 [kN/m ²]	σ_2 [kN/m ²]	ψ [-]	k_σ [-]	α [-]	c/t [-]	Class 1 Limit [-]	Class 2 Limit [-]	Class 3 Limit [-]	Class
1	I	85	5	1,531e+05	1,122e+05	0,73		1,00	17,00	25,88	31,43	38,71	1
3	I	85	5	1,072e+05	6,256e+04	0,58		1,00	17,00	25,88	31,43	41,06	1
5	I	85	5	6,234e+04	1,032e+05	0,60		1,00	17,00	25,88	31,43	40,72	1
7	I	85	5	1,082e+05	1,528e+05	0,71		1,00	17,00	25,88	31,43	39,09	1

Note: The Classification limits have been set according to Semi-Comp+.

The cross-section is classified as Class 1

Compression check

According to EN 1993-1-1 article 6.2.4 and formula (6.9)

Cross-section area	A	1,8360e-03	m ²
Compression resistance	$N_{c,Rd}$	504,90	kN
Unity check		0,39	-

Bending moment check for M_y

According to EN 1993-1-1 article 6.2.5 and formula (6.12),(6.13)

Plastic section modulus	W_{ply}	6,4590e-05	m ³
Plastic bending moment	$M_{ply,Rd}$	17,76	kNm
Unity check		0,08	-

Bending moment check for M_z

According to EN 1993-1-1 article 6.2.5 and formula (6.12),(6.13)

Plastic section modulus	W_{plz}	6,4590e-05	m ³
Plastic bending moment	$M_{plz,Rd}$	17,76	kNm
Unity check		0,07	-

Shear check for V_y

According to EN 1993-1-1 article 6.2.6 and formula (6.17)

Shear correction factor	η	1,20	
Shear area	A_v	9,1800e-04	m ²
Plastic shear resistance for V_y	$V_{ply,Rd}$	145,75	kN
Unity check		0,01	-

Shear check for V_z

According to EN 1993-1-1 article 6.2.6 and formula (6.17)

Shear correction factor	η	1,20	
Shear area	A_v	9,1800e-04	m ²
Plastic shear resistance for V_z	$V_{pl,z,Rd}$	145,75	kN
Unity check		0,01	-

Torsion check

According to EN 1993-1-1 article 6.2.7 and formula (6.23)

Index of fibre	Fibre	1	
Total torsional moment	T_{Ed}	8,0	MPa
Elastic shear resistance	T_{Ed}	158,8	MPa
Unity check		0,05	-

Combined Shear and Torsion check for V_y and $T_{t,Ed}$

According to EN 1993-1-1 article 6.2.6 & 6.2.7 and formula (6.25),(6.28)

Plastic shear resistance for V_y and $T_{t,Ed}$	$V_{pl,T,y,Rd}$	138,39	kN
Unity check		0,01	-

Combined Shear and Torsion check for V_z and $T_{t,Ed}$

According to EN 1993-1-1 article 6.2.6 & 6.2.7 and formula (6.25),(6.28)

Plastic shear resistance for V_z and $T_{t,Ed}$	$V_{pl,T,z,Rd}$	138,39	kN
Unity check		0,01	-

Combined bending, axial force and shear force check

According to EN 1993-1-1 article 6.2.9.1 and formula (6.41)

Design plastic moment resistance reduced due to N_{Ed}	$M_{N,y,Rd}$	14,00	kNm
Exponent of bending ratio y	α	2,01	
Design plastic moment resistance reduced due to N_{Ed}	$M_{N,z,Rd}$	14,00	kNm
Exponent of bending ratio z	β	2,01	

Unity check (6.41) = 0,01 + 0,01 = 0,02 -

Note: Since the shear forces are less than half the plastic shear resistances their effect on the moment resistances is neglected.

The member satisfies the section check.

.....**STABILITY CHECK:**.....

Classification for member buckling design

Decisive position for stability classification: 3,175 m

Classification according to EN 1993-1-1 article 5.5.2

Classification of Internal and Outstand parts according to EN 1993-1-1 Table 5.2 Sheet 1 & 2

Id	Type	c [mm]	t [mm]	σ_1 [kN/m ²]	σ_2 [kN/m ²]	ψ [-]	k_{σ} [-]	α [-]	c/t [-]	Class 1 Limit [-]	Class 2 Limit [-]	Class 3 Limit [-]	Class [-]
1	I	85	5	5,350e+04	8,684e+04	0,62		1,00	17,00	25,88	31,43	40,53	1
3	I	85	5	9,275e+04	1,599e+05	0,58		1,00	17,00	25,88	31,43	41,12	1
5	I	85	5	1,619e+05	1,286e+05	0,79		1,00	17,00	25,88	31,43	37,83	1
7	I	85	5	1,226e+05	5,549e+04	0,45		1,00	17,00	25,88	31,43	43,37	1

Note: The Classification limits have been set according to Semi-Comp+.

The cross-section is classified as Class 1

Flexural Buckling check

According to EN 1993-1-1 article 6.3.1.1 and formula (6.46)

Buckling parameters		yy	zz	
Sway type		sway	non-sway	
System length	L	3,175	3,175	m
Buckling factor	k	1,16	0,63	
Buckling length	l_{cr}	3,696	1,996	m
Critical Euler load	N_{cr}	411,22	1410,94	kN
Slenderness	λ	96,20	51,93	
Relative slenderness	λ_{rel}	1,11	0,60	
Limit slenderness	$\lambda_{rel,0}$	0,20	0,20	
Buckling curve		c	c	
Imperfection	α	0,49	0,49	
Reduction factor	χ	0,48	0,79	
Buckling resistance	$N_{b,Rd}$	242,34	397,08	kN

Flexural Buckling verification			
Cross-section area	A	1,8360e-03	m ²
Buckling resistance	$N_{b,Rd}$	242,34	kN
Unity check		0,82	-

Torsional(-Flexural) Buckling check

According to EN 1993-1-1 article 6.3.1.1 and formula (6.46)

Note: The cross-section concerns a RHS section which is not susceptible to Torsional(-Flexural) Buckling.**Lateral Torsional Buckling check**

According to EN 1993-1-1 article 6.3.2.1

Note: The cross-section concerns an RHS section with $h/b < 10/\lambda_{rel,x}^2$. This section is thus not susceptible to Lateral Torsional Buckling.**Bending and axial compression check**

According to EN 1993-1-1 article 6.3.3 and formula (6.61),(6.62)

Bending and axial compression check parameters		
Interaction method		alternative method 1
Cross-section area	A	1,8360e-03 m ²
Plastic section modulus	W _{pl,y}	6,4590e-05 m ³
Plastic section modulus	W _{pl,z}	6,4590e-05 m ³
Design compression force	N _{Ed}	197,65 kN
Design bending moment (maximum)	M _{y,Ed}	2,14 kNm
Design bending moment (maximum)	M _{z,Ed}	-1,30 kNm
Characteristic compression resistance	N _k	504,90 kN
Characteristic moment resistance	M _{y,Rk}	17,76 kNm
Characteristic moment resistance	M _{z,Rk}	17,76 kNm
Reduction factor	χ _y	0,48
Reduction factor	χ _z	0,79
Reduction factor	χ _{LT}	1,00
Interaction factor	k _{yy}	0,89
Interaction factor	k _{yz}	0,27
Interaction factor	k _{zy}	0,89
Interaction factor	k _{zz}	0,59

Maximum moment M_{y,Ed} is derived from beam B135 position 3,175 m.Maximum moment M_{z,Ed} is derived from beam B135 position 0,000 m.

Interaction method 1 parameters		
Critical Euler load	N _{cr,y}	411,22 kN
Critical Euler load	N _{cr,z}	1410,94 kN
Elastic critical load	N _{cr,El}	120772,76 kN
Plastic section modulus	W _{pl,y}	6,4590e-05 m ³
Elastic section modulus	W _{el,y}	5,4220e-05 m ³
Plastic section modulus	W _{pl,z}	6,4590e-05 m ³
Elastic section modulus	W _{el,z}	5,4220e-05 m ³
Second moment of area	I _y	2,7110e-06 m ⁴
Second moment of area	I _z	2,7110e-06 m ⁴
Torsional constant	I _t	4,4052e-06 m ⁴
Method for equivalent moment factor C _{my,0}		Table A.2 Line 2 (General)
Design bending moment (maximum)	M _{y,Ed}	2,14 kNm
Maximum relative deflection	δ _z	-1,5 mm
Equivalent moment factor	C _{my,0}	0,70
Method for equivalent moment factor C _{mz,0}		Table A.2 Line 1 (Linear)
Ratio of end moments	ψ _z	-0,82
Equivalent moment factor	C _{mz,0}	0,56
Factor	μ _y	0,68
Factor	μ _z	0,97
Factor	ε _y	0,37
Factor	α _{LT}	0,00
Critical moment for uniform bending	M _{cr,0}	445,83 kNm
Relative slenderness	λ _{rel,0}	0,20
Limit relative slenderness	λ _{rel,0,lim}	0,28
Equivalent moment factor	C _{my}	0,70
Equivalent moment factor	C _{mz}	0,56
Equivalent moment factor	C _{mLT}	1,00
Factor	b _{LT}	0,00
Factor	c _{LT}	0,00
Factor	d _{LT}	0,00
Factor	e _{LT}	0,00
Factor	w _y	1,19
Factor	w _z	1,19
Factor	η _{pl}	0,39
Maximum relative slenderness	λ _{rel,max}	1,11
Factor	C _{yy}	1,03
Factor	C _{yz}	0,58
Factor	C _{zy}	0,88
Factor	C _{zz}	1,08

Unity check (6.61) = 0,82 + 0,11 + 0,02 = 0,94 -
 Unity check (6.62) = 0,50 + 0,11 + 0,04 = 0,65 -
 The member satisfies the stability check.

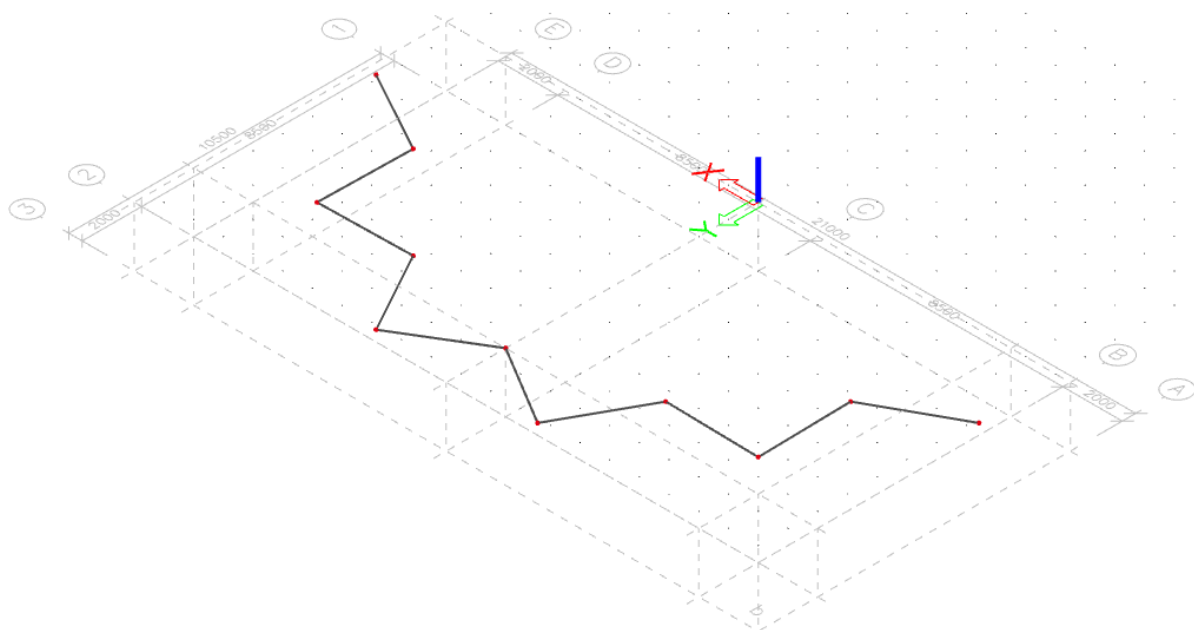

Slika 3.1.4.3. Prikaz položaja poprečnog presjeka

Name	Dijagonala
Type	CFRHS90X90X5
Shape type	Thin-walled
Initial shape	Available
Source and Type d...	
Source description	Rautaruukki Oyj / Stru...
Type description	Cold formed square a...
Parameters	
Material	S 275
Rectangular hollow se...	CFRHS90X90X5
Profile Library filter	All cross-sections
General	
Draw colour	Normal colour
Colour	
Fabrication	cold formed
Buckling curves	
Edit buckling curves	<input type="checkbox"/>
Flexural buckling y-y	c
Flexural buckling z-z	c

Slika 3.1.4.4. Poprečni presjek dijagonala na ostalim poljima

EC-EN 1993 Steel check ULS

Linear calculation

Combination: 1.

Coordinate system: Principal

Extreme 1D: Global

Selection: B136..B140, B189..B193

EN 1993-1-1 Code Check

National annex: Standard EN

Member B191 0,000 / 3,175 m CFRHS90X90X5 S 275 1. 0,82 -

Note: EN 1993-1-3 article 1.1(3) specifies that this part does not apply to cold formed CHS and RHS sections.
The default EN 1993-1-1 code check is executed instead of the EN 1993-1-3 code check.

Combination key	
1.	1.35*Vlastita težina + 1.50*snijeg + 0.30*vjetar + 0.60*temperatura -

Partial safety factors	
γ_{M0} for resistance of cross-sections	1,00
γ_{M1} for resistance to instability	1,00
γ_{M2} for resistance of net sections	1,25

Material			
Yield strength	f_y	275,0	MPa
Ultimate strength	f_u	430,0	MPa
Fabrication		Cold formed	

....SECTION CHECK:....

The critical check is on position 0,000 m

Internal forces		Calculated	Unit
Normal force	N_{Ed}	-167,85	kN
Shear force	$V_{y,Ed}$	-0,10	kN
Shear force	$V_{z,Ed}$	0,38	kN
Torsion	T_{Ed}	-0,21	kNm
Bending moment	$M_{y,Ed}$	0,29	kNm
Bending moment	$M_{z,Ed}$	0,09	kNm

Classification for cross-section design

Classification: according to EN 1993-1-1 article 5.5.2

Classification of Internal and Outstand parts according to EN 1993-1-1 Table 5.2 Sheet 1 & 2

Id	Type	c [mm]	t [mm]	σ_1 [kN/m ²]	σ_2 [kN/m ²]	ψ [-]	k_{σ} [-]	α [-]	c/t [-]	Class 1 Limit [-]	Class 2 Limit [-]	Class 3 Limit [-]	Class
1	I	75	5	9,465e+04	9,796e+04	0,97		1,00	15,00	25,88	31,43	35,54	1
3	I	75	5	9,893e+04	1,101e+05	0,90		1,00	15,00	25,88	31,43	36,41	1
5	I	75	5	1,106e+05	1,073e+05	0,97		1,00	15,00	25,88	31,43	35,50	1
7	I	75	5	1,064e+05	9,517e+04	0,89		1,00	15,00	25,88	31,43	36,46	1

Note: The Classification limits have been set according to Semi-Comp+.

The cross-section is classified as Class 1

Compression check

According to EN 1993-1-1 article 6.2.4 and formula (6.9)

Cross-section area	A	1,6360e-03	m ²
Compression resistance	$N_{c,Rd}$	449,90	kN
Unity check		0,37	-

Bending moment check for M_y

According to EN 1993-1-1 article 6.2.5 and formula (6.12),(6.13)

Plastic section modulus	$W_{pl,y}$	5,1410e-05	m ³
Plastic bending moment	$M_{pl,y,Rd}$	14,14	kNm
Unity check		0,02	-

Bending moment check for M_z

According to EN 1993-1-1 article 6.2.5 and formula (6.12),(6.13)

Plastic section modulus	$W_{pl,z}$	5,1410e-05	m ³
Plastic bending moment	$M_{pl,z,Rd}$	14,14	kNm
Unity check		0,01	-

Shear check for V_y

According to EN 1993-1-1 article 6.2.6 and formula (6.17)

Shear correction factor	η	1,20	
Shear area	A_v	8,1800e-04	m ²
Plastic shear resistance for V_y	$V_{pl,y,Rd}$	129,87	kN
Unity check		0,00	-

Shear check for V_{Ed}

According to EN 1993-1-1 article 6.2.6 and formula (6.17)

Shear correction factor	η	1,20	
Shear area	A_v	8,1800e-04	m ²
Plastic shear resistance for V_{Ed}	$V_{pl,Rd}$	129,87	kN
Unity check		0,00	-

Torsion check

According to EN 1993-1-1 article 6.2.7 and formula (6.23)

Index of fibre	Fibre	1	
Total torsional moment	T_{Ed}	2,9	MPa
Elastic shear resistance	T_{Rd}	158,8	MPa
Unity check		0,02	-

Note: The unity check for torsion is lower than the limit value of 0,05. Therefore torsion is considered as insignificant and is ignored in the combined checks.

Combined bending, axial force and shear force check

According to EN 1993-1-1 article 6.2.9.1 and formula (6.41)

Design plastic moment resistance reduced due to N_{Ed}	$M_{N,y,Rd}$	11,44	kNm
Exponent of bending ratio y	α	1,97	
Design plastic moment resistance reduced due to N_{Ed}	$M_{N,z,Rd}$	11,44	kNm
Exponent of bending ratio z	β	1,97	

Unity check (6.41) = 0,00 + 0,00 = 0,00 -

Note: Since the shear forces are less than half the plastic shear resistances their effect on the moment resistances is neglected.

The member satisfies the section check.

.....STABILITY CHECK:.....**Classification for member buckling design**

Decisive position for stability classification: 2,722 m

Classification according to EN 1993-1-1 article 5.5.2

Classification of Internal and Outstand parts according to EN 1993-1-1 Table 5.2 Sheet 1 & 2

Id	Type	c [mm]	t [mm]	σ_1 [kN/m ²]	σ_2 [kN/m ²]	ψ [-]	k_{σ} [-]	α [-]	c/t [-]	Class 1 Limit [-]	Class 2 Limit [-]	Class 3 Limit [-]	Class
1	I	75	5	9,092e+04	8,391e+04	0,92		1,00	15,00	25,88	31,43	36,09	1
3	I	75	5	8,523e+04	1,121e+05	0,76		1,00	15,00	25,88	31,43	38,31	1
5	I	75	5	1,144e+05	1,214e+05	0,94		1,00	15,00	25,88	31,43	35,85	1
7	I	75	5	1,201e+05	9,318e+04	0,78		1,00	15,00	25,88	31,43	38,09	1

Note: The Classification limits have been set according to Semi-Comp+. The cross-section is classified as Class 1

Flexural Buckling check

According to EN 1993-1-1 article 6.3.1.1 and formula (6.46)

Buckling parameters		yy	zz	
Sway type		sway	non-sway	
System length	L	3,175	3,175	m
Buckling factor	k	1,00	0,81	
Buckling length	l_{cr}	3,175	2,566	m
Critical Euler load	N_{cr}	396,61	607,45	kN
Slenderness	λ	92,46	74,71	
Relative slenderness	λ_{rel}	1,07	0,86	
Limit slenderness	$\lambda_{rel,0}$	0,20	0,20	
Buckling curve		c	c	
Imperfection	α	0,49	0,49	
Reduction factor	χ	0,50	0,62	
Buckling resistance	$N_{b,Rd}$	226,36	280,83	kN

Flexural Buckling verification

Cross-section area	A	1,6360e-03	m ²
Buckling resistance	$N_{b,Rd}$	226,36	kN
Unity check		0,74	-

Torsional(-Flexural) Buckling check

According to EN 1993-1-1 article 6.3.1.1 and formula (6.46)

Note: The cross-section concerns a RHS section which is not susceptible to Torsional(-Flexural) Buckling.

Lateral Torsional Buckling check

According to EN 1993-1-1 article 6.3.2.1

Note: The cross-section concerns an RHS section with $h/b < 10 / \lambda_{rel,z}^2$. This section is thus not susceptible to Lateral Torsional Buckling.

Bending and axial compression check

According to EN 1993-1-1 article 6.3.3 and formula (6.61),(6.62)

Bending and axial compression check parameters			
Interaction method		alternative method 1	
Cross-section area	A	1,6360e-03	m ²
Plastic section modulus	W _{pl,y}	5,1410e-05	m ³
Plastic section modulus	W _{pl,z}	5,1410e-05	m ³
Design compression force	N _{Ed}	167,85	kN
Design bending moment (maximum)	M _{y,Ed}	0,71	kNm
Design bending moment (maximum)	M _{z,Ed}	-0,22	kNm
Characteristic compression resistance	N _{sk}	449,90	kN
Characteristic moment resistance	M _{y,Rk}	14,14	kNm
Characteristic moment resistance	M _{z,Rk}	14,14	kNm
Reduction factor	χ _y	0,50	
Reduction factor	χ _z	0,62	
Reduction factor	χ _{LT}	1,00	
Interaction factor	k _{yy}	1,46	
Interaction factor	k _{yz}	0,41	
Interaction factor	k _{zy}	1,52	
Interaction factor	k _{zz}	0,73	

Maximum moment M_{y,Ed} is derived from beam B191 position 2,268 m.Maximum moment M_{z,Ed} is derived from beam B191 position 3,175 m.

Interaction method 1 parameters			
Critical Euler load	N _{cr,y}	396,61	kN
Critical Euler load	N _{cr,z}	607,45	kN
Elastic critical load	N _{cr,T}	108518,26	kN
Plastic section modulus	W _{pl,y}	5,1410e-05	m ³
Elastic section modulus	W _{el,y}	4,2870e-05	m ³
Plastic section modulus	W _{pl,z}	5,1410e-05	m ³
Elastic section modulus	W _{el,z}	4,2870e-05	m ³
Second moment of area	I _y	1,9293e-06	m ⁴
Second moment of area	I _z	1,9293e-06	m ⁴
Torsional constant	I _t	3,1626e-06	m ⁴
Method for equivalent moment factor C _{my,0}		Table A.2 Line 2 (General)	
Design bending moment (maximum)	M _{y,Ed}	0,71	kNm
Maximum relative deflection	δ _L	-2,0	mm
Equivalent moment factor	C _{my,0}	1,05	
Method for equivalent moment factor C _{mz,0}		Table A.2 Line 1 (Linear)	
Ratio of end moments	ψ _z	-0,38	
Equivalent moment factor	C _{mz,0}	0,64	
Factor	μ _y	0,73	
Factor	μ _z	0,87	
Factor	ε _y	0,16	
Factor	ε _z	0,00	
Critical moment for uniform bending	M _{cr,0}	318,61	kNm
Relative slenderness	λ _{rel,0}	0,21	
Limit relative slenderness	λ _{rel,0,lim}	0,19	
Equivalent moment factor	C _{my}	1,05	
Equivalent moment factor	C _{mz}	0,64	
Equivalent moment factor	C _{myLT}	1,00	
Factor	b _{LT}	0,00	
Factor	c _{LT}	0,00	
Factor	d _{LT}	0,00	
Factor	e _{LT}	0,00	
Factor	w _y	1,20	
Factor	w _z	1,20	
Factor	η _{pl}	0,37	
Maximum relative slenderness	λ _{rel,max}	1,07	
Factor	C _{yy}	0,91	
Factor	C _{yz}	0,95	
Factor	C _{zy}	0,63	
Factor	C _{zz}	1,06	

Unity check (6.61) = 0,74 + 0,07 + 0,01 = 0,82 -

Unity check (6.62) = 0,60 + 0,08 + 0,01 = 0,69 -

The member satisfies the stability check.

4.1.5. Horizontale

Horizontale se sastoje od poprečnog presjeka dimenzija 70x70x4 (mm).

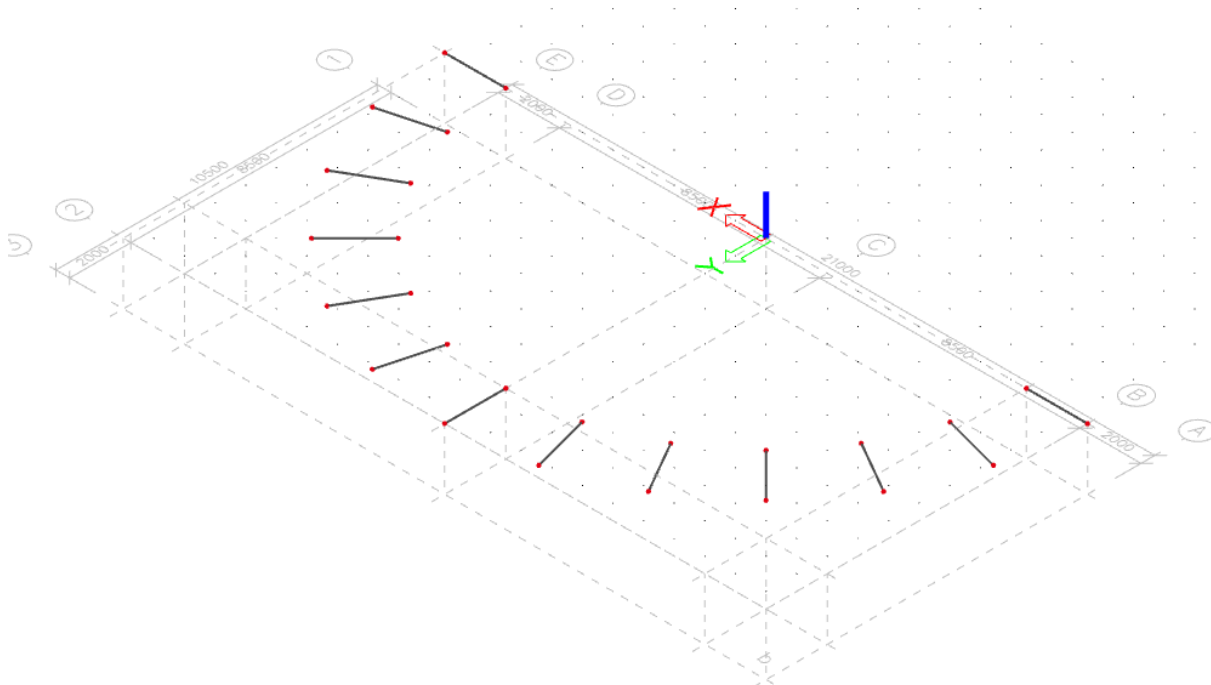

Slika 3.1.5.1. Prikaz položaja poprečnog presjeka

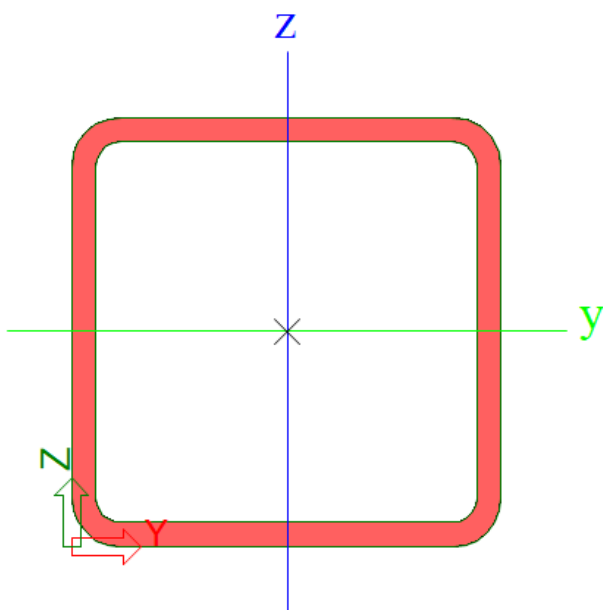

Name	Horizontala
Type	CFRHS70X70X4
Shape type	Thin-walled
Initial shape	Available
Source and Type d...	
Source description	Rautaruukki Oyj / Stru...
Type description	Cold formed square a...
Parameters	
Material	S 275
Rectangular hollow se...	CFRHS70X70X4
Profile Library filter	All cross-sections
General	
Draw colour	Normal colour
Colour	██████████
Fabrication	cold formed
Buckling curves	
Edit buckling curves	<input type="checkbox"/>
Flexural buckling y-y	c
Flexural buckling z-z	c

Slika 3.1.5.2. Poprečni presjek horizontala

EC-EN 1993 Steel check ULS

Linear calculation

Combination: 2.

Coordinate system: Principal

Extreme 1D: Global

Selection: B14, B15, B20, B23, B26, B29, B32, B141, B142, B147, B150, B153, B156

EN 1993-1-1 Code Check

National annex: Standard EN

Member B15	0,000 / 2,000 m	CFRHS70X70X4	S 275	2.	0,32 -
------------	-----------------	--------------	-------	----	--------

Note: EN 1993-1-3 article 1.1(3) specifies that this part does not apply to cold formed CHS and RHS sections. The default EN 1993-1-1 code check is executed instead of the EN 1993-1-3 code check.

Combination key	
2. / 1.35*	Vlastita težina + 0.30*vjetar + 0.60*temperatura + + 1.50*pješaci

Partial safety factors	
γ_{M0} for resistance of cross-sections	1,00
γ_{M1} for resistance to instability	1,00
γ_{M2} for resistance of net sections	1,25

Material	
Yield strength	f_y 275,0 MPa
Ultimate strength	f_u 430,0 MPa
Fabrication	Cold formed

...:SECTION CHECK:...

The critical check is on position 0,000 m

Internal forces		Calculated	Unit
Normal force	N_{Ed}	88,29	kN
Shear force	$V_{y,Ed}$	-0,53	kN
Shear force	$V_{z,Ed}$	0,41	kN
Torsion	T_{Ed}	0,11	kNm
Bending moment	$M_{y,Ed}$	-0,15	kNm
Bending moment	$M_{z,Ed}$	0,63	kNm

Classification for cross-section design

Classification according to EN 1993-1-1 article 5.5.2

Classification of Internal and Outstand parts according to EN 1993-1-1 Table 5.2 Sheet 1 & 2

Id	Type	c [mm]	t [mm]	σ_1 [kN/m ²]	σ_2 [kN/m ²]	ψ [-]	k_{σ} [-]	α [-]	c/t [-]	Class 1 Limit [-]	Class 2 Limit [-]	Class 3 Limit [-]	Class
1	I	58	4	-1,057e+05	-5,484e+04								
3	I	58	4	-5,215e+04	-6,401e+04								
5	I	58	4	-6,834e+04	-1,192e+05								
7	I	58	4	-1,219e+05	-1,100e+05								

Note: The Classification limits have been set according to Semi-Comp+.

The cross-section is classified as Class 1

Tension check

According to EN 1993-1-1 article 6.2.3 and formula (6.5)

Cross-section area	A	1,0150e-03	m ²
Plastic tension resistance	$N_{pl,Rd}$	279,12	kN
Ultimate tension resistance	$N_{u,Rd}$	314,24	kN
Tension resistance	$N_{t,Rd}$	279,12	kN
Unity check		0,32	-

Bending moment check for M_y

According to EN 1993-1-1 article 6.2.5 and formula (6.12),(6.13)

Plastic section modulus	$W_{pl,y}$	2,4760e-05	m ³
Plastic bending moment	$M_{pl,y,Rd}$	6,81	kNm
Unity check		0,02	-

Bending moment check for M_z

According to EN 1993-1-1 article 6.2.5 and formula (6.12),(6.13)

Plastic section modulus	$W_{pl,z}$	2,4760e-05	m ³
Plastic bending moment	$M_{pl,z,Rd}$	6,81	kNm
Unity check		0,09	-

Shear check for V_y

According to EN 1993-1-1 article 6.2.6 and formula (6.17)

Shear correction factor	η	1,20	
Shear area	A_v	5,0750e-04	m ²
Plastic shear resistance for V_y	$V_{pl,y,Rd}$	80,58	kN
Unity check		0,01	-

Shear check for V_z

According to EN 1993-1-1 article 6.2.6 and formula (6.17)

Shear correction factor	η	1,20	
Shear area	A_v	5,0750e-04	m ²
Plastic shear resistance for V_z	$V_{pl,z,Rd}$	80,58	kN
Unity check		0,01	-

Torsion check

According to EN 1993-1-1 article 6.2.7 and formula (6.23)

Index of fibre	Fibre	1	
Total torsional moment	T_{Ed}	3,0	MPa
Elastic shear resistance	T_{Rd}	158,8	MPa
Unity check		0,02	-

Note: The unity check for torsion is lower than the limit value of 0,05. Therefore torsion is considered as insignificant and is ignored in the combined checks.

Combined bending, axial force and shear force check

According to EN 1993-1-1 article 6.2.9.1 and formula (6.41)

Design plastic moment resistance reduced due to N_{Ed}	$M_{N,y,Rd}$	6,00	kNm
Exponent of bending ratio y	α	1,87	
Design plastic moment resistance reduced due to N_{Ed}	$M_{N,z,Rd}$	6,00	kNm
Exponent of bending ratio z	β	1,87	

Unity check (6.41) = 0,00 + 0,01 = 0,02 -

Note: Since the shear forces are less than half the plastic shear resistances their effect on the moment resistances is neglected.

The member satisfies the section check.

...:STABILITY CHECK:...

Classification for member buckling design

Decisive position for stability classification: 0,000 m

Classification according to EN 1993-1-1 article 5.5.2

Classification of Internal and Outstand parts according to EN 1993-1-1 Table 5.2 Sheet 1 & 2

Id	Type	c [mm]	t [mm]	σ_1 [kN/m ²]	σ_2 [kN/m ²]	Ψ [-]	k_σ [-]	α [-]	c/t [-]	Class 1 Limit [-]	Class 2 Limit [-]	Class 3 Limit [-]	Class
1	I	58	4	-1,057e+05	-5,484e+04								
3	I	58	4	-5,215e+04	-6,401e+04								
5	I	58	4	-6,834e+04	-1,192e+05								
7	I	58	4	-1,219e+05	-1,100e+05								

Note: The Classification limits have been set according to Semi-Comp+. The cross-section is classified as Class 1

Lateral Torsional Buckling check

According to EN 1993-1-1 article 6.3.2.1

Note: The cross-section concerns an RHS section with ' $h / b < 10 / \lambda_{rel,z}$ '. This section is thus not susceptible to Lateral Torsional Buckling.

The member satisfies the stability check.

4.2. Dimenzioniranje četveropojasne čelične konstrukcije

4.2.1. Gornji pojas

Gornji pojas sastoji se od poprečnog presjeka dimenzija 180x100x5 (mm).

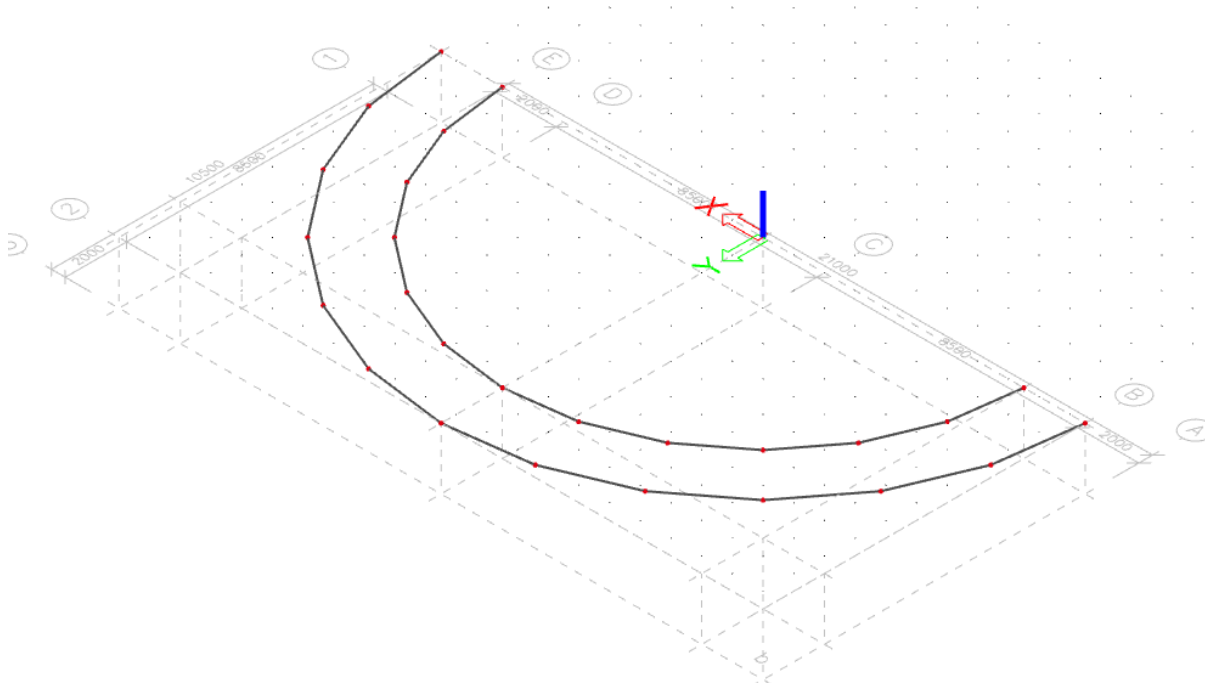

Slika 3.2.1.1. Prikaz položaja poprečnog presjeka

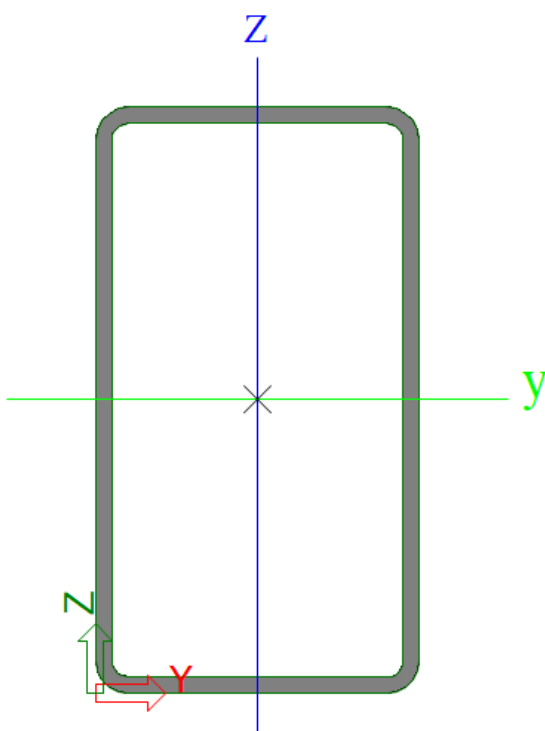

Name	Gornji pojas
Type	CFRHS180X100X5
Shape type	Thin-walled
Initial shape	Available
Source and Type d...	
Source description	Rautaruukki Oyj / Stru...
Type description	Cold formed square a...
Parameters	
Material	S 275
Rectangular hollow se...	CFRHS180X100X5
Profile Library filter	All cross-sections
General	
Draw colour	Normal colour
Colour	
Fabrication	cold formed
Buckling curves	
Edit buckling curves	<input type="checkbox"/>
Flexural buckling y-y	c
Flexural buckling z-z	c

Slika 3.2.1.2. Poprečni presjek gornjeg pojasa

EC-EN 1993 Steel check ULS

Linear calculation

Combination: 1.

Coordinate system: Principal

Extreme 1D: Global

Selection: All

EN 1993-1-1 Code Check

National annex: Standard EN

Member B142 0,000 / 2,741 m CFRHS180X100X5 S 275 1. 0,76 -

Note: EN 1993-1-3 article 1.1(3) specifies that this part does not apply to cold formed CHS and RHS sections.
The default EN 1993-1-1 code check is executed instead of the EN 1993-1-3 code check.

Combination key	
1.	/ 1.35*LC1 + 1.50*snijeg + 0.60*temperatura - + 0.30*vjetar

Partial safety factors	
γ_{M0} for resistance of cross-sections	1,00
γ_{M1} for resistance to instability	1,00
γ_{M2} for resistance of net sections	1,25

Material			
Yield strength	f_y	275,0	MPa
Ultimate strength	f_u	430,0	MPa
Fabrication		Cold formed	

...:SECTION CHECK:...:

The critical check is on position 0,000 m

Internal forces		Calculated	Unit
Normal force	N_{Ed}	552,28	kN
Shear force	$V_{y,Ed}$	-2,91	kN
Shear force	$V_{z,Ed}$	4,22	kN
Torsion	T_{Ed}	1,08	kNm
Bending moment	$M_{y,Ed}$	-8,30	kNm
Bending moment	$M_{z,Ed}$	4,23	kNm

Classification for cross-section design

Classification: according to EN 1993-1-1 article 5.5.2

Classification of Internal and Outstand parts: according to EN 1993-1-1 Table 5.2 Sheet 1 & 2

Id	Type	c [mm]	t [mm]	σ_1 [kN/m ²]	σ_2 [kN/m ²]	ψ [-]	k_{σ} [-]	α [-]	c/t [-]	Class 1 Limit [-]	Class 2 Limit [-]	Class 3 Limit [-]	Class
1	I	85	5	-1,847e+05	-1,051e+05								
3	I	165	5	-1,041e+05	-2,260e+05								
5	I	85	5	-2,344e+05	-3,140e+05								
7	I	165	5	-3,150e+05	-1,931e+05								

Note: The Classification limits have been set according to Semi-Comp+.
The cross-section is classified as Class 1

Tension check

According to EN 1993-1-1 article 6.2.3 and formula (6.5)

Cross-section area	A	2,6360e-03	m ²
Plastic tension resistance	$N_{pl,Rd}$	724,90	kN
Ultimate tension resistance	$N_{u,Rd}$	816,11	kN
Tension resistance	$N_{t,Rd}$	724,90	kN
Unity check		0,76	-

Bending moment check for M_y

According to EN 1993-1-1 article 6.2.5 and formula (6.12),(6.13)

Plastic section modulus	$W_{pl,y}$	1,5402e-04	m ³
Plastic bending moment	$M_{pl,y,Rd}$	42,36	kNm
Unity check		0,20	-

Bending moment check for M_z

According to EN 1993-1-1 article 6.2.5 and formula (6.12),(6.13)

Plastic section modulus	$W_{pl,z}$	1,0259e-04	m ³
Plastic bending moment	$M_{pl,z,Rd}$	28,21	kNm
Unity check		0,15	-

Shear check for V_y

According to EN 1993-1-1 article 6.2.6 and formula (6.17)

Shear correction factor	η	1,20	
Shear area	A_v	9,4143e-04	m ²
Plastic shear resistance for V_y	$V_{pl,y,Rd}$	149,47	kN
Unity check		0,02	-

Shear check for V_z

According to EN 1993-1-1 article 6.2.6 and formula (6.17)

Shear correction factor	η	1,20	
Shear area	A_w	1,6946e-03	m ²
Plastic shear resistance for V_z	$V_{pl,z,Rd}$	259,05	kN
Unity check		0,02	-

Torsion check

According to EN 1993-1-1 article 6.2.7 and formula (6.23)

Index of fibre	Fibre	1	
Total torsional moment	T_{Ed}	6,5	MPa
Elastic shear resistance	T_{Rd}	158,8	MPa
Unity check		0,04	-

Note: The unity check for torsion is lower than the limit value of 0,05. Therefore torsion is considered as insignificant and is ignored in the combined checks.

Combined bending, axial force and shear force check

According to EN 1993-1-1 article 6.2.9.1 and formula (6.41)

Design plastic moment resistance reduced due to N_{Ed}	$M_{N,y,Rd}$	13,45	kNm
Exponent of bending ratio y	α	4,82	
Design plastic moment resistance reduced due to N_{Ed}	$M_{N,z,Rd}$	7,98	kNm
Exponent of bending ratio z	β	4,82	

Unity check (6.41) = $0,10 + 0,05 = 0,14$ -

Note: Since the shear forces are less than half the plastic shear resistances their effect on the moment resistances is neglected.

The member satisfies the section check.

...:**STABILITY CHECK**::...

Classification for member buckling design

Decisive position for stability classification: 0,000 m

Classification according to EN 1993-1-1 article 5.5.2

Classification of Internal and Outstand parts according to EN 1993-1-1 Table 5.2 Sheet 1 & 2

[d	Type	c (mm)	t (mm)	σ_1 [kN/m ²]	σ_2 [kN/m ²]	ψ [-]	k_{σ} [-]	α [-]	c/t [-]	Class 1 Limit [-]	Class 2 Limit [-]	Class 3 Limit [-]	Class
1	I	85	5	-1,847e+05	-1,051e+05								
3	I	165	5	-1,041e+05	-2,260e+05								
5	I	85	5	-2,344e+05	-3,140e+05								
7	I	165	5	-3,150e+05	-1,931e+05								

Note: The Classification limits have been set according to Semi-Comp+.

The cross-section is classified as Class 1

Lateral Torsional Buckling check

According to EN 1993-1-1 article 6.3.2.1

Note: The cross-section concerns an RHS section with $h/b < 10 / \lambda_{rel,z}^2$.

This section is thus not susceptible to Lateral Torsional Buckling.

The member satisfies the stability check.

4.2.2. Donji pojas

Donji pojas sastoji se od poprečnog presjeka jednakih dimenzija kao i gornji pojas – 180x100x5 (mm).

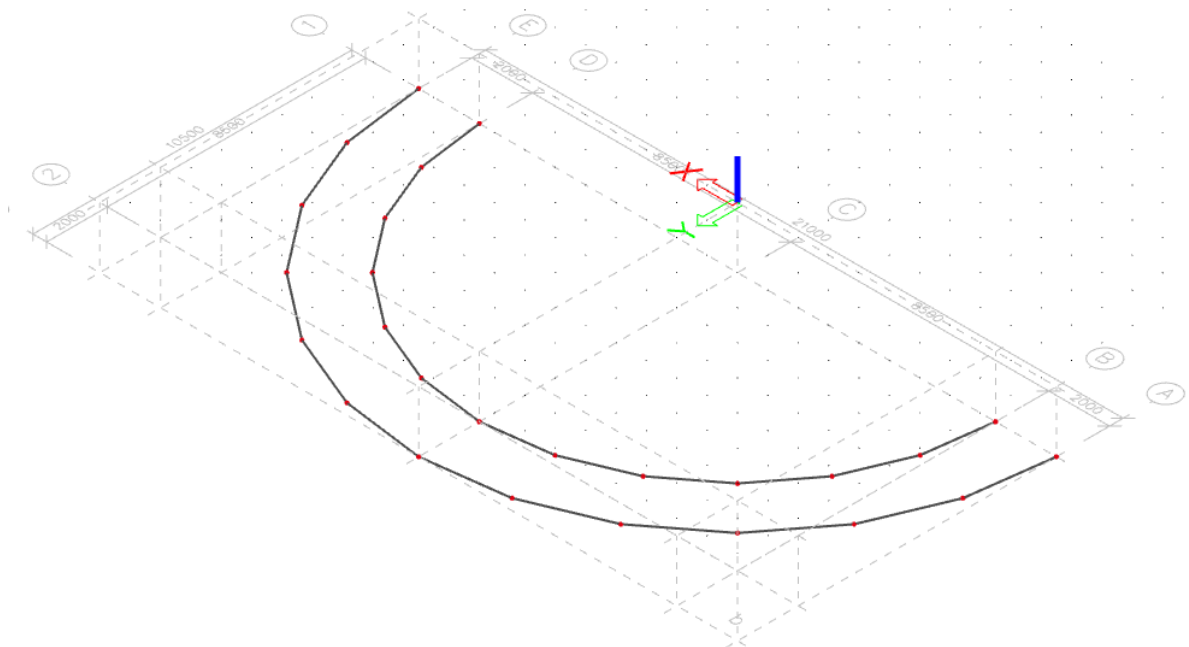

Slika 3.2.2.1. Prikaz položaja poprečnog presjeka

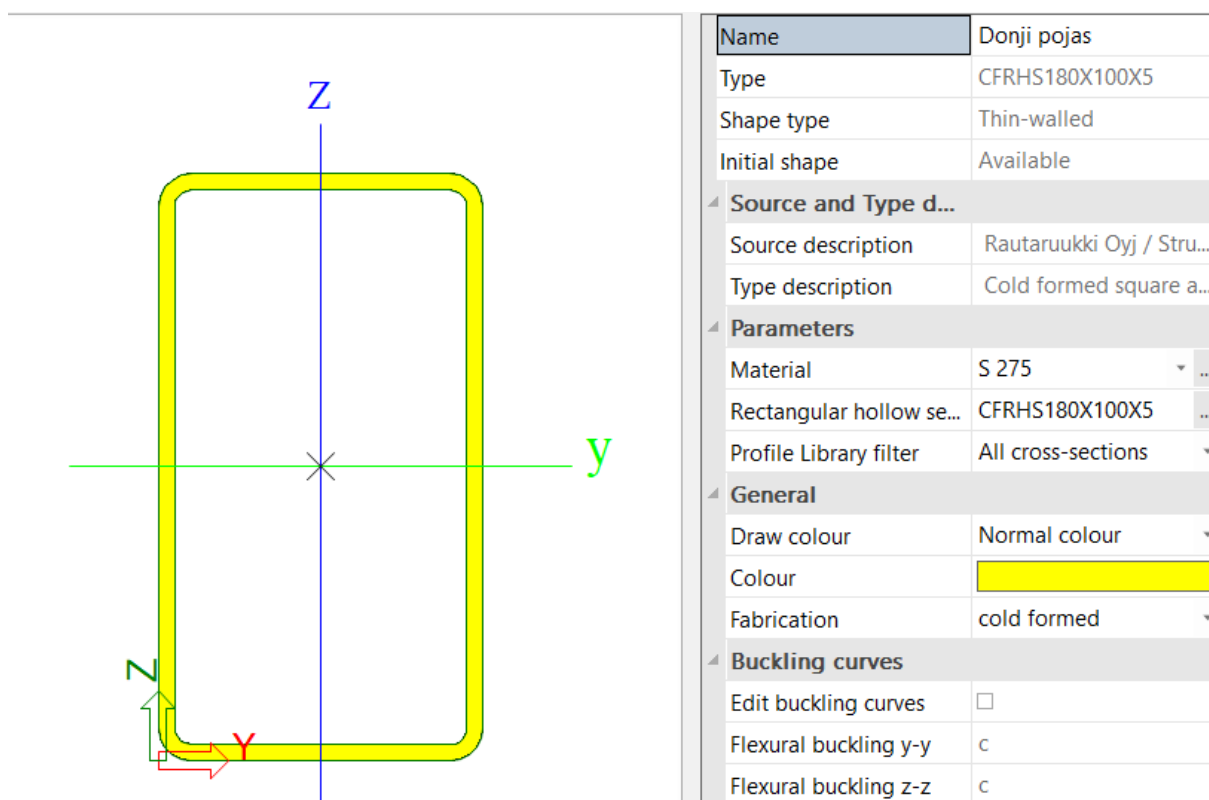

Slika 3.2.2.2. Poprečni presjek donjeg pojasa

EC-EN 1993 Steel check ULS

Linear calculation

Combination: 1.

Coordinate system: Principal

Extreme 1D: Global

Selection: All

EN 1993-1-1 Code Check

National annex: Standard EN

Member B43 0,000 / 2,741 m **CFRHS180X100X5** **S 275** **1.** **0,68 -**

Note: EN 1993-1-3 article 1.1(3) specifies that this part does not apply to cold formed CHS and RHS sections. The default EN 1993-1-1 code check is executed instead of the EN 1993-1-3 code check.

Combination key

1. / 1.35*LC1 + 1.50*snijeg + 0.60*temperatura - + 0.30*vjetar

Partial safety factors

γ_{M0} for resistance of cross-sections	1,00
γ_{M1} for resistance to instability	1,00
γ_{M2} for resistance of net sections	1,25

Material

Yield strength	f_y	275,0	MPa
Ultimate strength	f_u	430,0	MPa
Fabrication		Cold formed	

....SECTION CHECK:....The critical check is on position **0,000 m**

Internal forces		Calculated	Unit
Normal force	N_{Ed}	-221,39	kN
Shear force	$V_{y,Ed}$	-0,29	kN
Shear force	$V_{z,Ed}$	2,53	kN
Torsion	T_{Ed}	-0,43	kNm
Bending moment	$M_{y,Ed}$	-6,49	kNm
Bending moment	$M_{z,Ed}$	1,00	kNm

Classification for cross-section design

Classification: according to EN 1993-1-1 article 5.5.2

Classification of Internal and Outstand parts according to EN 1993-1-1 Table 5.2 Sheet 1 & 2

Id	Type	c [mm]	t [mm]	σ_1 [kN/m ²]	σ_2 [kN/m ²]	ψ [-]	γ_{c0} [-]	α [-]	c/t [-]	Class 1 Limit [-]	Class 2 Limit [-]	Class 3 Limit [-]	Class
1	I	85	5	1,251e+05	1,440e+05	0,87		1,00	17,00	25,88	31,43	36,80	1
3	I	165	5	1,422e+05	4,688e+04	0,33		1,00	33,00	25,88	31,43	45,77	3
5	I	85	5	4,288e+04	2,404e+04	0,56		1,00	17,00	25,88	31,43	41,45	1
7	I	165	5	2,582e+04	1,211e+05	0,21		1,00	33,00	25,88	31,43	46,32	3

Note: The Classification limits have been set according to Semi-Comp+.

The cross-section is classified as Class 3

Semi-Comp+ properties

Material coefficient	ϵ	0,92	
Flange class 2 slenderness limit	$\beta_{2,y,f}$	31,43	
Flange class 3 slenderness limit	$\beta_{3,y,f}$	35,13	
Web class 2 slenderness limit	$\beta_{2,y,w}$	76,73	
Web class 3 slenderness limit	$\beta_{3,y,w}$	114,63	
Web class 2 slenderness limit	$\beta_{2,z,w}$	31,43	
Web class 3 slenderness limit	$\beta_{3,z,w}$	35,13	
Web slenderness ratio	c/t_w	33,00	
Flange slenderness ratio	c/t_f	17,00	
Reference slenderness ratio	$c/t_{ref,y}$	0,00	
Reference slenderness ratio	$c/t_{ref,z}$	0,42	
Interpolated section modulus	$W_{3,y}$	1,5402e-04	m ³
Interpolated section modulus	$W_{3,z}$	9,7393e-05	m ³

Note: The resistance for this semi-compact section has been calculated according to Semi-Comp+.**Compression check**

According to EN 1993-1-1 article 6.2.4 and formula (6.9)

Cross-section area	A	2,6360e-03	m ²
Compression resistance	$N_{c,Rd}$	724,90	kN
Unity check		0,31	-

Bending moment check for M_y

According to EN 1993-1-1 article 6.2.5 and formula (6.12)/(6.13)

Interpolated section modulus	$W_{3,y}$	1,5402e-04	m ³
Interpolated bending resistance	$M_{3,y,Rd}$	42,36	kNm
Unity check		0,15	-

Bending moment check for M_z

According to EN 1993-1-1 article 6.2.5 and formula (6.12)/(6.13)

Interpolated section modulus	$W_{3,z}$	9,7393e-05	m ³
Interpolated bending resistance	$M_{3,z,Rd}$	26,78	kNm
Unity check		0,04	-

Shear check for V_y

According to EN 1993-1-1 article 6.2.6 and formula (6.17)

Shear correction factor	η	1,20	
Shear area	A_v	9,4143e-04	m ²
Plastic shear resistance for V_y	$V_{pl,y,Rd}$	149,47	kN
Unity check		0,00	-

Shear check for V_z

According to EN 1993-1-1 article 6.2.6 and formula (6.17)

Shear correction factor	η	1,20	
Shear area	A_v	1,6946e-03	m ²
Plastic shear resistance for V_z	$V_{pl,z,Rd}$	269,05	kN
Unity check		0,01	-

Torsion check

According to EN 1993-1-1 article 6.2.7 and formula (6.23)

Index of fibre	Fibre	1	
Total torsional moment	T_{Ed}	2,6	MPa
Elastic shear resistance	T_{Rd}	158,8	MPa
Unity check		0,02	-

Note: The unity check for torsion is lower than the limit value of 0,05. Therefore torsion is considered as insignificant and is ignored in the combined checks.

Combined bending, axial force and shear force check

According to EN 1993-1-1 article 6.2.9.1 and formula (6.41)

Interpolated moment resistance reduced due to N_{Ed}	$M_{N,3,y,Rd}$	29,42	kNm
Exponent of bending ratio y	α	1,86	
Interpolated moment resistance reduced due to N_{Ed}	$M_{N,3,z,Rd}$	18,60	kNm
Exponent of bending ratio z	β	1,86	

Unity check (6.41) = 0,06 + 0,00 = 0,07 -

Note: Since the shear forces are less than half the plastic shear resistances their effect on the moment resistances is neglected.

The member satisfies the section check.

....STABILITY CHECK....**Classification for member buckling design**

Decisive position for stability classification: 0,000 m

Classification according to EN 1993-1-1 article 5.5.2

Classification of Internal and Outstand parts according to EN 1993-1-1 Table 5.2 Sheet 1 & 2

Id	Type	c [mm]	t [mm]	σ_1 [kN/m ²]	σ_2 [kN/m ²]	Ψ [-]	k_α [-]	α [-]	c/t [-]	Class 1 Limit [-]	Class 2 Limit [-]	Class 3 Limit [-]	Class
1	I	85	5	1,251e+05	1,440e+05	0,87		1,00	17,00	25,88	31,43	36,80	1
3	I	165	5	1,422e+05	4,688e+04	0,33		1,00	33,00	25,88	31,43	45,77	3
5	I	85	5	4,288e+04	2,404e+04	0,56		1,00	17,00	25,88	31,43	41,45	1
7	I	165	5	2,582e+04	1,211e+05	0,21		1,00	33,00	25,88	31,43	48,32	3

Note: The Classification limits have been set according to Semi-Comp+.

The cross-section is classified as Class 3

Flexural Buckling check

According to EN 1993-1-1 article 6.3.1.1 and formula (6.46)

Buckling parameters	yy	zz	
Sway type	sway	non-sway	
System length	L	2,741	m
Buckling factor	k	1,80	0,67
Buckling length	l_{cr}	4,925	m
Critical Euler load	N_{cr}	960,54	kN
Slenderness	λ	75,42	44,53
Relative slenderness	λ_{rel}	0,87	0,51
Limit slenderness	$\lambda_{rel,0}$	0,20	0,20
Buckling curve	c	c	
Imperfection	α	0,49	0,49

Buckling parameters		yy	zz	
Reduction factor	χ	0,62	0,84	
Buckling resistance	$N_{b,Rd}$	448,83	605,84	kN

Flexural Buckling verification			
Cross-section area	A	2,6360e-03	m ²
Buckling resistance	$N_{b,Rd}$	448,83	kN
Unity check		0,49	-

Torsional(-Flexural) Buckling check

According to EN 1993-1-1 article 6.3.1.1 and formula (6.46)

Note: The cross-section concerns a RHS section which is not susceptible to Torsional(-Flexural) Buckling.

Lateral Torsional Buckling check

According to EN 1993-1-1 article 6.3.2.1

Note: The cross-section concerns an RHS section with $t_h / b < 10 / \lambda_{red,z}^2$.

This section is thus not susceptible to Lateral Torsional Buckling.

Bending and axial compression check

According to EN 1993-1-1 article 6.3.3 and formula (6.61),(6.62)

Bending and axial compression check parameters			
Interaction method		alternative method 1	
Cross-section area	A	2,6360e-03	m ²
Interpolated section modulus	$W_{3,y}$	1,5402e-04	m ³
Interpolated section modulus	$W_{3,z}$	9,7393e-05	m ³
Design compression force	N_{Ed}	221,39	kN
Design bending moment (maximum)	$M_{y,Ed}$	-6,49	kNm
Design bending moment (maximum)	$M_{z,Ed}$	1,00	kNm
Characteristic compression resistance	N_{uk}	724,90	kN
Characteristic moment resistance	$M_{y,Rk}$	42,36	kNm
Characteristic moment resistance	$M_{z,Rk}$	26,78	kNm
Reduction factor	χ_y	0,62	
Reduction factor	χ_z	0,84	
Reduction factor	χ_{LT}	1,00	
Interaction factor	k_{yy}	1,05	
Interaction factor	k_{yz}	0,59	
Interaction factor	k_{zy}	0,82	
Interaction factor	k_{zz}	1,03	

Maximum moment $M_{y,Ed}$ is derived from beam B43 position 0,000 m.

Maximum moment $M_{z,Ed}$ is derived from beam B43 position 0,000 m.

Interaction method 1 parameters			
Critical Euler load	$N_{cr,y}$	960,54	kN
Critical Euler load	$N_{cr,z}$	2755,76	kN
Elastic critical load	$N_{cr,T}$	142019,30	kN
Interpolated section modulus	$W_{3,y}$	1,5402e-04	m ³
Elastic section modulus	$W_{el,y}$	1,2491e-04	m ³
Interpolated section modulus	$W_{3,z}$	9,7393e-05	m ³
Elastic section modulus	$W_{el,z}$	9,0350e-05	m ³
Second moment of area	I_y	1,1242e-05	m ⁴
Second moment of area	I_z	4,5177e-06	m ⁴
Torsional constant	I_t	1,0448e-05	m ⁴
Method for equivalent moment factor $C_{my,0}$		Table A.2 Line 2 (General)	
Design bending moment (maximum)	$M_{y,Ed}$	-6,49	kNm
Maximum relative deflection	δ_y	1,3	mm
Equivalent moment factor	$C_{my,0}$	0,92	
Method for equivalent moment factor $C_{mz,0}$		Table A.2 Line 2 (General)	
Design bending moment (maximum)	$M_{z,Ed}$	1,00	kNm
Maximum relative deflection	δ_z	-0,4	mm
Equivalent moment factor	$C_{mz,0}$	0,96	
Factor	μ_y	0,90	
Factor	μ_z	0,99	
Factor	ϵ_y	0,62	
Factor	ϵ_z	0,07	
Critical moment for uniform bending	$M_{cr,0}$	1028,67	kNm
Relative slenderness	$\lambda_{rel,0}$	0,20	
Limit relative slenderness	$\lambda_{rel,lim}$	0,26	
Equivalent moment factor	C_{my}	0,92	
Equivalent moment factor	C_{mz}	0,96	
Equivalent moment factor	C_{mLT}	1,00	
Factor	b_{LT}	0,00	

Interaction method 1 parameters		
Factor	c_{LT}	0,00
Factor	d_{LT}	0,00
Factor	e_{LT}	0,02
Factor	w_y	1,23
Factor	w_z	1,08
Factor	η_{pl}	0,31
Maximum relative slenderness	$\lambda_{rel,max}$	0,87
Factor	C_{yy}	1,02
Factor	C_{yz}	0,89
Factor	C_{zy}	0,92
Factor	C_{zz}	0,99

Unity check (6.61) = $0,49 + 0,16 + 0,02 = 0,68$ -

Unity check (6.62) = $0,37 + 0,13 + 0,04 = 0,53$ -

The member satisfies the stability check.

4.2.3. Vertikala

Vertikale četveropojasne rešetke sastoje se od poprečnog presjeka dimenzija 70x70x4 (mm).

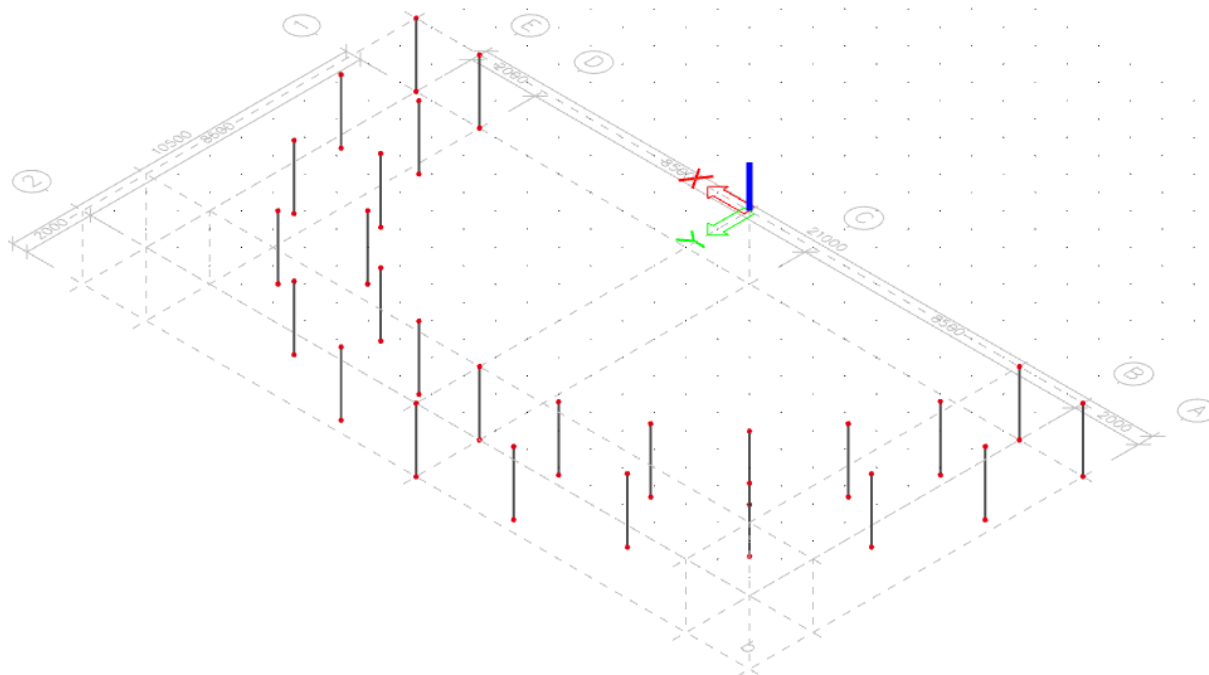

Slika 3.2.3.1. Prikaz položaja poprečnog presjeka

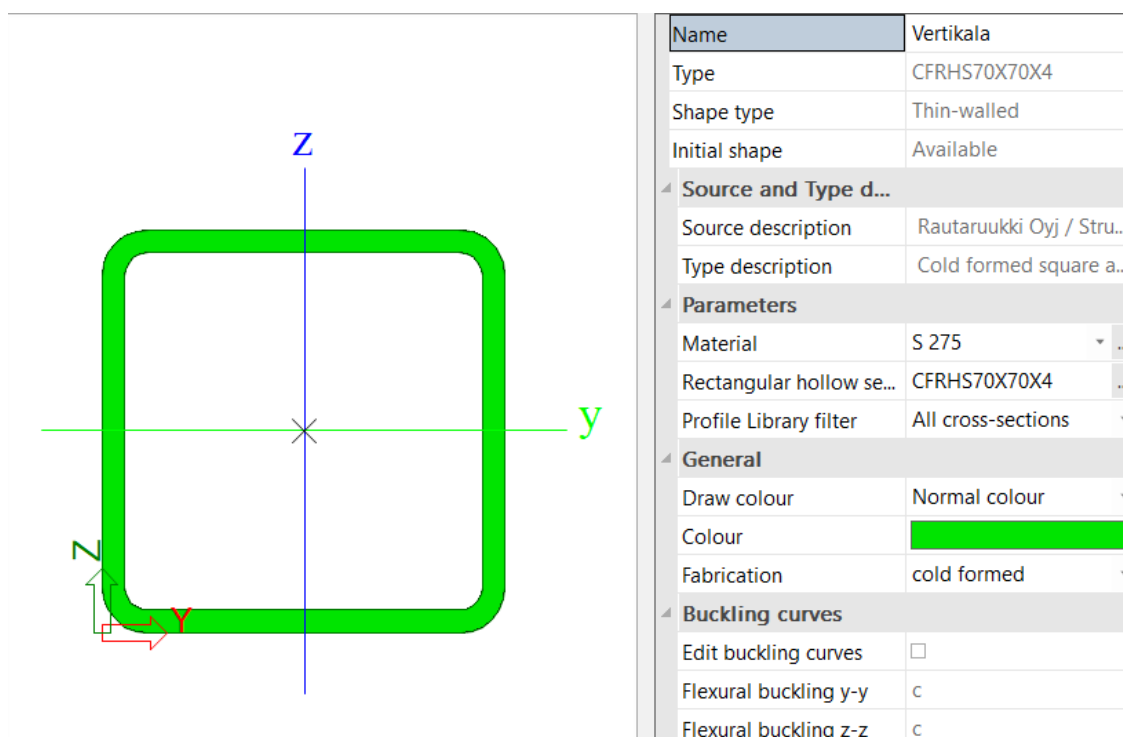

Slika 3.2.3.2. Poprečni presjek vertikala

EC-EN 1993 Steel check ULS

Linear calculation

Combination: 1.

Coordinate system: Principal

Extreme 1D: Global

Selection: All

EN 1993-1-1 Code Check

National annex: Standard EN

Member B63 2,000 / 2,000 m CFRHS70X70X4 S 275 1. 0,30 -

Note: EN 1993-1-3 article 1.1(3) specifies that this part does not apply to cold formed CHS and RHS sections. The default EN 1993-1-1 code check is executed instead of the EN 1993-1-3 code check.

Combination key

1. / 1.35*LC1 + 1.50*snijeg + 0.60*temperatura - + 0.30*vjetar

Partial safety factors

γ_{M0} for resistance of cross-sections	1,00
γ_{M1} for resistance to instability	1,00
γ_{M2} for resistance of net sections	1,25

Material

Yield strength	f_y	275,0	MPa
Ultimate strength	f_u	430,0	MPa
Fabrication		Cold formed	

....SECTION CHECK:....

The critical check is on position 2,000 m

Internal forces		Calculated	Unit
Normal force	N_{Ed}	-25,22	kN
Shear force	$V_{y,Ed}$	-0,74	kN
Shear force	$V_{x,Ed}$	0,54	kN
Torsion	T_{Ed}	0,14	kNm
Bending moment	$M_{y,Ed}$	0,87	kNm
Bending moment	$M_{z,Ed}$	-0,79	kNm

Classification for cross-section design

Classification: according to EN 1993-1-1 article 5.5.2

Classification of Internal and Outstand parts according to EN 1993-1-1 Table 5.2 Sheet 1 & 2

Id	Type	c [mm]	t [mm]	σ_1 [kN/m ²]	σ_2 [kN/m ²]	ψ [-]	k_{σ} [-]	α [-]	c/t [-]	Class 1 Limit [-]	Class 2 Limit [-]	Class 3 Limit [-]	Class
1	I	58	4	1,675e+04	-4,680e+04	-2,79		0,26	14,50	126,28	145,57	363,57	1
3	I	58	4	-4,634e+04	2,375e+04	-1,95		0,34	14,50	98,22	113,22	236,28	1
5	I	58	4	3,297e+04	9,651e+04	0,34		1,00	14,50	25,88	31,43	45,53	1
7	I	58	4	9,606e+04	2,596e+04	0,27		1,00	14,50	25,88	31,43	47,04	1

Note: The Classification limits have been set according to Semi-Comp+.

The cross-section is classified as Class 1

Compression check

According to EN 1993-1-1 article 6.2.4 and formula (6.9)

Cross-section area	A	1,0150e-03	m ²
Compression resistance	$N_{c,Rd}$	279,12	kN
Unity check		0,09	-

Bending moment check for M_y

According to EN 1993-1-1 article 6.2.5 and formula (6.12),(6.13)

Plastic section modulus	$W_{pl,y}$	2,4760e-05	m ³
Plastic bending moment	$M_{pl,y,Rd}$	6,81	kNm
Unity check		0,13	-

Bending moment check for M_z

According to EN 1993-1-1 article 6.2.5 and formula (6.12),(6.13)

Plastic section modulus	$W_{pl,z}$	2,4760e-05	m ³
Plastic bending moment	$M_{pl,z,Rd}$	6,81	kNm
Unity check		0,12	-

Shear check for V_y

According to EN 1993-1-1 article 6.2.6 and formula (6.17)

Shear correction factor	η	1,20	
Shear area	A_v	5,0750e-04	m ²
Plastic shear resistance for V_y	$V_{pl,y,Rd}$	80,58	kN
Unity check		0,01	-

Shear check for V_z

According to EN 1993-1-1 article 6.2.6 and formula (6.17)

Shear correction factor	η	1,20	
Shear area	A_v	5,0750e-04	m ²
Plastic shear resistance for V_z	$V_{pl,z,Rd}$	80,58	kN
Unity check		0,01	-

Torsion check

According to EN 1993-1-1 article 6.2.7 and formula (6.23)

Index of fibre	Fibre	I	
Total torsional moment	T_{Ed}	4,1	MPa
Elastic shear resistance	T_{Rd}	158,8	MPa
Unity check		0,03	-

Note: The unity check for torsion is lower than the limit value of 0,05. Therefore torsion is considered as insignificant and is ignored in the combined checks.

Combined bending, axial force and shear force check

According to EN 1993-1-1 article 6.2.9.1 and formula (6.41)

Design plastic moment resistance reduced due to N_{Ed}	$M_{N,y,Rd}$	6,81	kNm
Exponent of bending ratio y	α	1,68	
Design plastic moment resistance reduced due to N_{Ed}	$M_{N,z,Rd}$	6,81	kNm
Exponent of bending ratio z	β	1,68	

Unity check (6.41) = 0,03 + 0,03 = 0,06 -

Note: Since the shear forces are less than half the plastic shear resistances their effect on the moment resistances is neglected.

The member satisfies the section check.

STABILITY CHECK:...

Classification for member buckling design

Decisive position for stability classification: 2,000 m

Classification according to EN 1993-1-1 article 5.5.2

Classification of Internal and Outstand parts according to EN 1993-1-1 Table 5.2 Sheet 1 & 2

Id	Type	c [mm]	t [mm]	σ_1 [kN/m ²]	σ_2 [kN/m ²]	ψ [-]	k_{σ} [-]	α [-]	c/t [-]	Class 1 Limit [-]	Class 2 Limit [-]	Class 3 Limit [-]	Class
1	I	58	4	1,675e+04	-4,680e+04	-2,79		0,26	14,50	126,28	145,52	363,57	1
3	I	58	4	-4,634e+04	2,375e+04	-1,95		0,34	14,50	98,22	113,22	236,28	1
5	I	58	4	3,297e+04	9,651e+04	0,34		1,00	14,50	25,88	31,43	45,53	1
7	I	58	4	9,606e+04	2,596e+04	0,27		1,00	14,50	25,88	31,43	47,04	1

Note: The Classification limits have been set according to Semi-Comp+. The cross-section is classified as Class 1

Flexural Buckling check

According to EN 1993-1-1 article 6.3.1.1 and formula (6.46)

Buckling parameters		yy	zz	
Sway type		sway	non-sway	
System length	L	2,000	2,000	m
Buckling factor	k	1,10	0,52	
Buckling length	l_{cr}	2,200	1,035	m
Critical Euler load	N_{cr}	308,81	1395,04	kN
Slenderness	λ	82,54	38,83	
Relative slenderness	λ_{rel}	0,95	0,45	
Limit slenderness	$\lambda_{rel,0}$	0,20	0,20	
Buckling curve	c	c	c	
Imperfection	α	0,49	0,49	
Reduction factor	χ	0,57	0,87	
Buckling resistance	$N_{b,Rd}$	158,83	243,40	kN

Flexural Buckling verification			
Cross-section area	A	1,0150e-03	m ²
Buckling resistance	$N_{b,Rd}$	158,83	kN
Unity check		0,16	-

Torsional(-Flexural) Buckling check

According to EN 1993-1-1 article 6.3.1.1 and formula (6.46)

Note: The cross-section concerns a RHS section which is not susceptible to Torsional(-Flexural) Buckling.

Lateral Torsional Buckling check

According to EN 1993-1-1 article 6.3.2.1

Note: The cross-section concerns an RHS section with $t_h / b < 10 / \lambda_{rel,z}^2$. This section is thus not susceptible to Lateral Torsional Buckling.

Bending and axial compression check

According to EN 1993-1-1 article 6.3.3 and formula (6.61),(6.62)

Bending and axial compression check parameters			
Interaction method		alternative method 1	
Cross-section area	A	1,0150e-03	m ²
Plastic section modulus	W _{pl,y}	2,4760e-05	m ³
Plastic section modulus	W _{pl,z}	2,4760e-05	m ³
Design compression force	N _{Ed}	25,22	kN
Design bending moment (maximum)	M _{y,Ed}	0,87	kNm
Design bending moment (maximum)	M _{z,Ed}	-0,79	kNm
Characteristic compression resistance	N _{tk}	279,12	kN
Characteristic moment resistance	M _{y,Rk}	6,81	kNm
Characteristic moment resistance	M _{z,Rk}	6,81	kNm
Reduction factor	χ _y	0,57	
Reduction factor	χ _z	0,87	
Reduction factor	χ _{LT}	1,00	
Interaction factor	k _{yy}	0,75	
Interaction factor	k _{yz}	0,35	
Interaction factor	k _{zy}	0,48	
Interaction factor	k _{zz}	0,59	

Maximum moment M_{y,Ed} is derived from beam B63 position 2,000 m.Maximum moment M_{z,Ed} is derived from beam B63 position 2,000 m.

Interaction method 1 parameters			
Critical Euler load	N _{cr,y}	308,81	kN
Critical Euler load	N _{cr,z}	1395,04	kN
Elastic critical load	N _{cr,T}	67566,73	kN
Plastic section modulus	W _{pl,y}	2,4760e-05	m ³
Elastic section modulus	W _{el,y}	2,0610e-05	m ³
Plastic section modulus	W _{pl,z}	2,4760e-05	m ³
Elastic section modulus	W _{el,z}	2,0610e-05	m ³
Second moment of area	I _y	7,2120e-07	m ⁴
Second moment of area	I _z	7,2120e-07	m ⁴
Torsional constant	I _t	1,1852e-06	m ⁴
Method for equivalent moment factor C _{my,0}		Table A.2 Line 1 (Linear)	
Ratio of end moments	ψ _y	-0,23	
Equivalent moment factor	C _{my,0}	0,73	
Method for equivalent moment factor C _{mz,0}		Table A.2 Line 1 (Linear)	
Ratio of end moments	ψ _z	-0,88	
Equivalent moment factor	C _{mz,0}	0,60	
Factor	μ _T	0,96	
Factor	μ _z	1,00	
Factor	ε _z	1,70	
Factor	α _{LT}	0,00	
Critical moment for uniform bending	M _{cr,0}	189,42	kNm
Relative slenderness	λ _{rel,0}	0,19	
Limit relative slenderness	λ _{rel,0,lim}	0,28	
Equivalent moment factor	C _{my}	0,73	
Equivalent moment factor	C _{mz}	0,60	
Equivalent moment factor	C _{my,T}	1,00	
Factor	b _{LT}	0,00	
Factor	c _{LT}	0,00	
Factor	d _{LT}	0,00	
Factor	e _{LT}	0,00	
Factor	w _y	1,20	
Factor	w _z	1,20	
Factor	η _{pl}	0,09	
Maximum relative slenderness	λ _{rel,max}	0,95	
Factor	C _{yy}	1,01	
Factor	C _{yz}	1,00	
Factor	C _{zy}	0,99	
Factor	C _{zz}	1,02	

Unity check (6.61) = 0,16 + 0,10 + 0,04 = 0,30 -

Unity check (6.62) = 0,10 + 0,06 + 0,07 = 0,23 -

The member satisfies the stability check.

4.2.4. Dijagonale – horizontalne gornje

Dijagonale – horizontalne donje, sastoje se od dva poprečna presjeka. U prvom i drugom polju su dimenzija 110x110x5 (mm) dok su na ostalim poljima dimenzija 90x90x5 (mm).

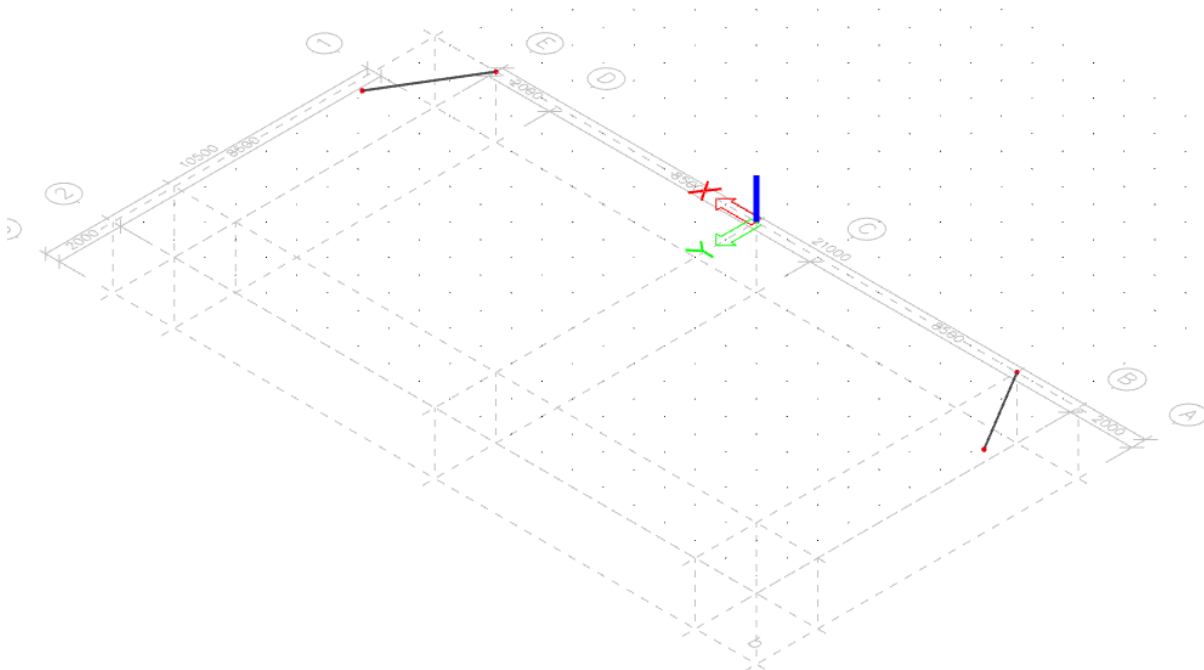

Slika 3.2.4.1. Prikaz položaja poprečnog presjeka

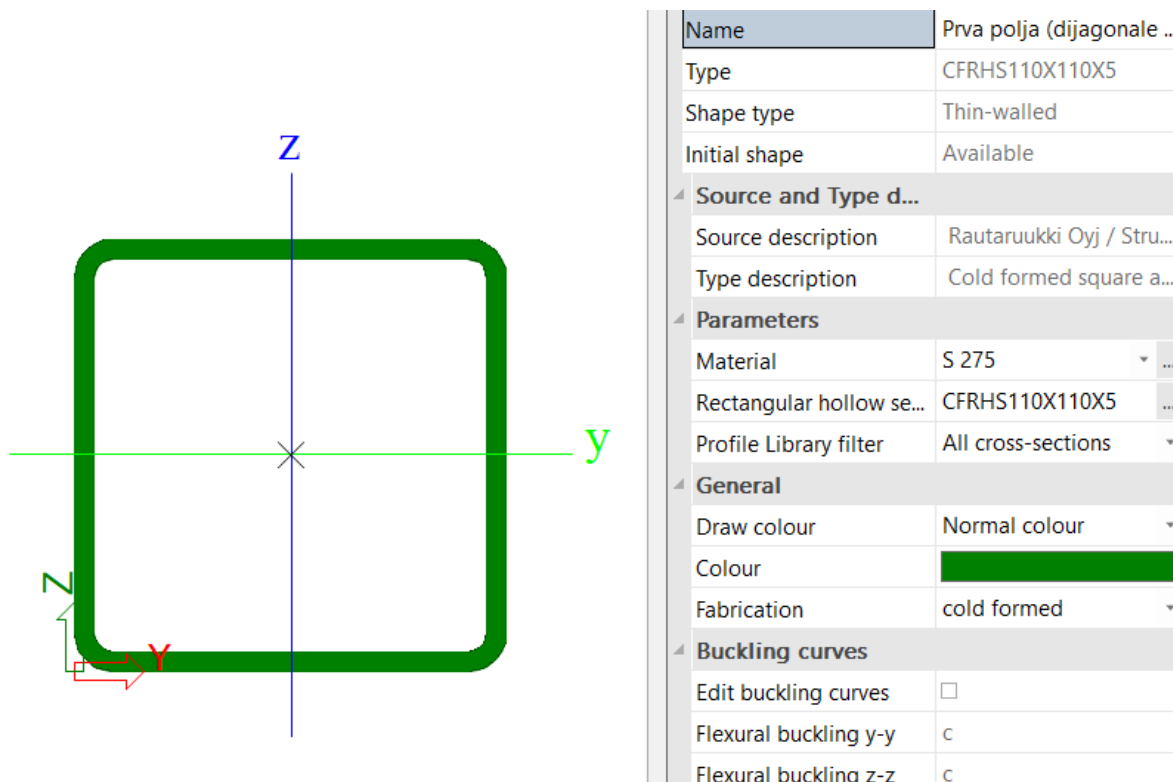

Slika 3.2.4.2. Poprečni presjek dijagonala – horizontalnih gornjih na prvim poljima

EC-EN 1993 Steel check ULS

Linear calculation
 Combination: 1.
 Coordinate system: Principal
 Extreme 1D: Global
 Selection: All

EN 1993-1-1 Code Check
 National annex: Standard EN

Member B180 | **0,000 / 3,175 m** | **CFRHS110X110X5** | **S 275** | **1.** | **0,93 -**

Note: EN 1993-1-3 article 1.1(3) specifies that this part does not apply to cold formed CHS and RHS sections. The default EN 1993-1-1 code check is executed instead of the EN 1993-1-3 code check.

Combination key	
1.	/ 1.35*LC1 + 1.50*snijeg + 0.60*temperatura - + 0.30*vjetar

Partial safety factors	
γ_{M0} for resistance of cross-sections	1,00
γ_{M1} for resistance to instability	1,00
γ_{M2} for resistance of net sections	1,25

Material			
Yield strength	f_y	275,0	MPa
Ultimate strength	f_u	430,0	MPa
Fabrication		Cold formed	

....:SECTION CHECK:....

The critical check is on position **0,000 m**

Internal forces		Calculated	Unit
Normal force	N_{Ed}	-264,58	kN
Shear force	$V_{y,Ed}$	-1,21	kN
Shear force	$V_{z,Ed}$	2,28	kN
Torsion	T_{Ed}	0,73	kNm
Bending moment	$M_{y,Ed}$	-3,36	kNm
Bending moment	$M_{z,Ed}$	2,31	kNm

Classification for cross-section design

Classification according to EN 1993-1-1 article 5.5.2
 Classification of Internal and Outstand parts according to EN 1993-1-1 Table 5.2 Sheet 1 & 2

Id	Type	c [mm]	t [mm]	σ_1 [kN/m ²]	σ_2 [kN/m ²]	ψ [-]	k_{σ} [-]	α [-]	c/t [-]	Class 1 Limit [-]	Class 2 Limit [-]	Class 3 Limit [-]	Class
1	I	95	5	1,482e+05	2,078e+05	0,71		1,00	19,00	25,88	31,43	39,01	1
3	I	95	5	2,063e+05	1,195e+05	0,58		1,00	19,00	25,88	31,43	41,13	1
5	I	95	5	1,118e+05	5,221e+04	0,47		1,00	19,00	25,88	31,43	43,10	1
7	I	95	5	5,364e+04	1,405e+05	0,38		1,00	19,00	25,88	31,43	44,72	1

Note: The Classification limits have been set according to Semi-Comp+. The cross-section is classified as Class 1

Compression check

According to EN 1993-1-1 article 6.2.4 and formula (6.9)

Cross-section area	A	2,0360e-03	m ²
Compression resistance	$N_{c,Rd}$	559,90	kN
Unity check		0,47	-

Bending moment check for M_y

According to EN 1993-1-1 article 6.2.5 and formula (6.12),(6.13)

Plastic section modulus	$W_{pl,y}$	7,9270e-05	m ³
Plastic bending moment	$M_{pl,y,Rd}$	21,80	kNm
Unity check		0,15	-

Bending moment check for M_z

According to EN 1993-1-1 article 6.2.5 and formula (6.12),(6.13)

Plastic section modulus	$W_{pl,z}$	7,9270e-05	m ³
Plastic bending moment	$M_{pl,z,Rd}$	21,80	kNm
Unity check		0,11	-

Shear check for V_y

According to EN 1993-1-1 article 6.2.6 and formula (6.17)

Shear correction factor	η	1,20	
Shear area	A_v	1,0180e-03	m ²
Plastic shear resistance for V_y	$V_{pl,y,Rd}$	161,63	kN
Unity check		0,01	-

Shear check for V_z

According to EN 1993-1-1 article 6.2.6 and formula (6.17)

Shear correction factor	η	1,20	
Shear area	A_v	1,0180e-03	m ²
Plastic shear resistance for V_z	$V_{pl,Rd}$	151,63	kN
Unity check		0,01	-

Torsion check

According to EN 1993-1-1 article 6.2.7 and formula (6.23)

Index of fibre	Fibre	1	
Total torsional moment	T_{Ed}	6,6	MPa
Elastic shear resistance	T_{Rd}	158,8	MPa
Unity check		0,04	-

Note: The unity check for torsion is lower than the limit value of 0,05. Therefore torsion is considered as insignificant and is ignored in the combined checks.

Combined bending, axial force and shear force check

According to EN 1993-1-1 article 6.2.9.1 and formula (6.41)

Design plastic moment resistance reduced due to N_{Ed}	$M_{N_y,Rd}$	14,93	kNm
Exponent of bending ratio γ	α	2,22	
Design plastic moment resistance reduced due to N_{Ed}	$M_{N_z,Rd}$	14,93	kNm
Exponent of bending ratio z	β	2,22	

Unity check (6.41) = 0,04 + 0,02 = 0,05 -

Note: Since the shear forces are less than half the plastic shear resistances their effect on the moment resistances is neglected.

The member satisfies the section check.

...::STABILITY CHECK::...

Classification for member buckling design

Decisive position for stability classification: 0,000 m

Classification according to EN 1993-1-1 article 5.5.2

Classification of Internal and Outstand parts according to EN 1993-1-1 Table 5.2 Sheet 1 & 2

Id	Type	c [mm]	t [mm]	σ_1 [kN/m ²]	σ_2 [kN/m ²]	ψ [-]	k_{σ} [-]	α [-]	c/t [-]	Class 1 Limit [-]	Class 2 Limit [-]	Class 3 Limit [-]	Class [-]
1	I	95	5	1,482e+05	2,078e+05	0,71		1,00	19,00	25,88	31,43	39,01	1
3	I	95	5	2,063e+05	1,195e+05	0,58		1,00	19,00	25,88	31,43	41,13	1
5	I	95	5	1,118e+05	5,221e+04	0,47		1,00	19,00	25,88	31,43	43,10	1
7	I	95	5	5,364e+04	1,405e+05	0,38		1,00	19,00	25,88	31,43	44,72	1

Note: The Classification limits have been set according to Semi-Comp+. The cross-section is classified as Class 1

Flexural Buckling check

According to EN 1993-1-1 article 6.3.1.1 and formula (6.46)

Buckling parameters		yy	zz
Sway type		sway	non-sway
System length	L	3,175	3,175
Buckling factor	k	1,00	1,00
Buckling length	l_{cr}	3,175	3,175
Critical Euler load	N_{cr}	756,40	756,40
Slenderness	λ	74,69	74,69
Relative slenderness	λ_{rel}	0,86	0,86
Limit slenderness	$\lambda_{rel,0}$	0,20	0,20
Buckling curve	c	c	c
Imperfection	α	0,49	0,49
Reduction factor	χ	0,62	0,62
Buckling resistance	$N_{b,Rd}$	349,58	349,58

Flexural Buckling verification

Cross-section area	A	2,0360e-03	m ²
Buckling resistance	$N_{b,Rd}$	349,58	kN
Unity check		0,76	-

Torsional(-Flexural) Buckling check

According to EN 1993-1-1 article 6.3.1.1 and formula (6.46)

Note: The cross-section concerns a RHS section which is not susceptible to Torsional(-Flexural) Buckling.**Lateral Torsional Buckling check**

According to EN 1993-1-1 article 6.3.2.1

Note: The cross-section concerns an RHS section with $t_h / b < 10 / \lambda_{rel,z}$. This section is thus not susceptible to Lateral Torsional Buckling.

Bending and axial compression check

According to EN 1993-1-1 article 6.3.3 and formula (6.61),(6.62)

Bending and axial compression check parameters			
Interaction method		alternative method 1	
Cross-section area	A	2,0360e-03	m ²
Plastic section modulus	W _{pl,y}	7,9270e-05	m ³
Plastic section modulus	W _{pl,z}	7,9270e-05	m ³
Design compression force	N _{Ed}	264,58	kN
Design bending moment (maximum)	M _{y,Ed}	-3,36	kNm
Design bending moment (maximum)	M _{z,Ed}	2,31	kNm
Characteristic compression resistance	N _{tk}	559,90	kN
Characteristic moment resistance	M _{y,Rk}	21,80	kNm
Characteristic moment resistance	M _{z,Rk}	21,80	kNm
Reduction factor	χ _y	0,62	
Reduction factor	χ _z	0,62	
Reduction factor	χ _{LT}	1,00	
Interaction factor	k _{yy}	0,84	
Interaction factor	k _{yz}	0,38	
Interaction factor	k _{zy}	0,55	
Interaction factor	k _{zz}	0,60	

Maximum moment M_{y,Ed} is derived from beam B180 position 0,000 m.Maximum moment M_{z,Ed} is derived from beam B180 position 0,000 m.

Interaction method 1 parameters			
Critical Euler load	N _{cr,y}	756,40	kN
Critical Euler load	N _{cr,z}	756,40	kN
Elastic critical load	N _{cr,T}	133029,08	kN
Plastic section modulus	W _{pl,y}	7,9270e-05	m ³
Elastic section modulus	W _{el,y}	6,6900e-05	m ³
Plastic section modulus	W _{pl,z}	7,9270e-05	m ³
Elastic section modulus	W _{el,z}	6,6900e-05	m ³
Second moment of area	I _y	3,6795e-06	m ⁴
Second moment of area	I _z	3,6795e-06	m ⁴
Torsional constant	I _t	5,9360e-06	m ⁴
Method for equivalent moment factor C _{my,0}		Table A.2 Line 2 (General)	
Design bending moment (maximum)	M _{y,Ed}	-3,36	kNm
Maximum relative deflection	δ _z	0,7	mm
Equivalent moment factor	C _{my,0}	0,71	
Method for equivalent moment factor C _{mz,0}		Table A.2 Line 1 (Linear)	
Ratio of end moments	ψ _z	-0,67	
Equivalent moment factor	C _{mz,0}	0,52	
Factor	μ _y	0,83	
Factor	μ _z	0,83	
Factor	ε _y	0,39	
Factor	a _{LT}	0,00	
Critical moment for uniform bending	M _{cr,0}	603,07	kNm
Relative slenderness	λ _{rel,0}	0,19	
Limit relative slenderness	λ _{rel,0,lim}	0,30	
Equivalent moment factor	C _{my}	0,71	
Equivalent moment factor	C _{mz}	0,52	
Equivalent moment factor	C _{myLT}	1,00	
Factor	b _{LT}	0,00	
Factor	c _{LT}	0,00	
Factor	d _{LT}	0,00	
Factor	e _{LT}	0,00	
Factor	w _y	1,18	
Factor	w _z	1,18	
Factor	η _{pl}	0,47	
Maximum relative slenderness	λ _{rel,max}	0,86	
Factor	C _{yy}	1,08	
Factor	C _{yz}	1,07	
Factor	C _{zy}	0,98	
Factor	C _{zz}	1,12	

Unity check (6.61) = 0,76 + 0,13 + 0,04 = 0,93 -

Unity check (6.62) = 0,76 + 0,09 + 0,06 = 0,91 -

The member satisfies the stability check.

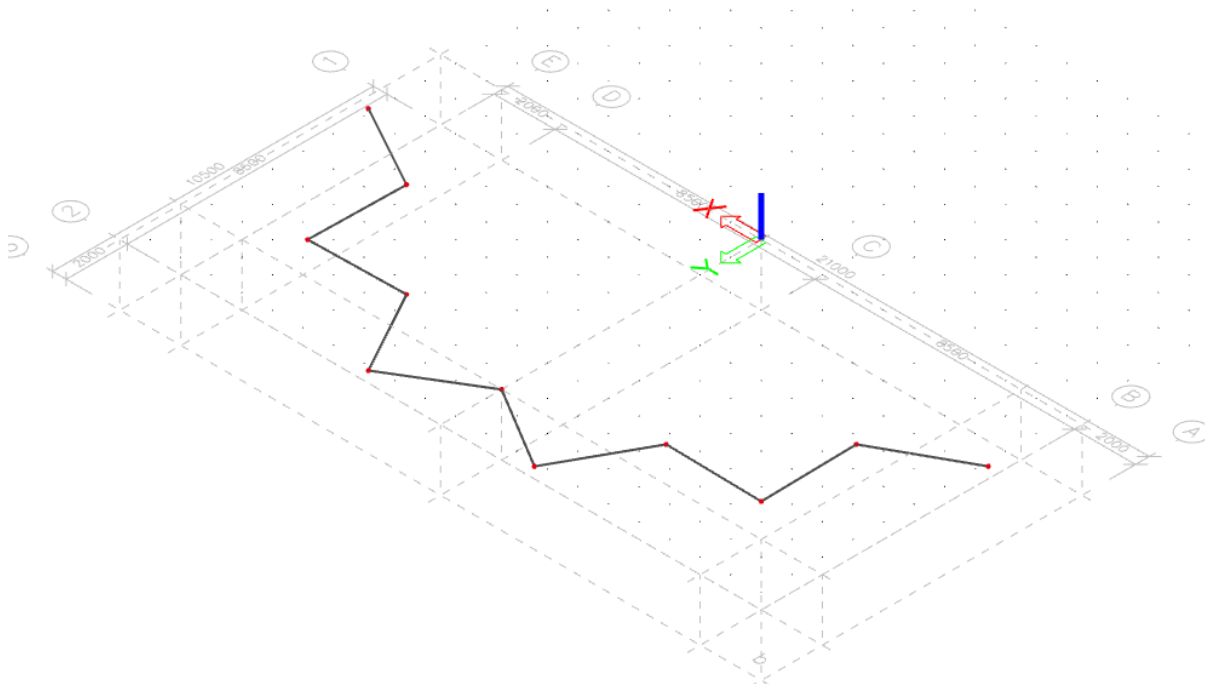

Slika 3.2.4.3. Prikaz položaja poprečnog presjeka

Name	Dijagonala horizontal...
Type	CFRHS90X90X5
Shape type	Thin-walled
Initial shape	Available
Source and Type d...	
Source description	Rautaruukki Oyj / Stru...
Type description	Cold formed square a...
Parameters	
Material	S 275
Rectangular hollow se...	CFRHS90X90X5
Profile Library filter	All cross-sections
General	
Draw colour	Normal colour
Colour	
Fabrication	cold formed
Buckling curves	
Edit buckling curves	<input type="checkbox"/>
Flexural buckling y-y	c
Flexural buckling z-z	c

Slika 3.2.4.4. Poprečni presjek dijagonala – horizatanih gornjih na ostalim poljima

EC-EN 1993 Steel check ULS

Linear calculation
 Combination: 1.
 Coordinate system: Principal
 Extreme 1D: Global
 Selection: All

EN 1993-1-1 Code Check
 National annex: Standard EN

Member B136	0,000 / 3,175 m	CFRHS90X90X5	S 275	1.	0,64 -
--------------------	------------------------	---------------------	--------------	-----------	---------------

Note: EN 1993-1-3 article 1.1(3) specifies that this part does not apply to cold formed CHS and RHS sections. The default EN 1993-1-1 code check is executed instead of the EN 1993-1-3 code check.

Combination key	
1.	/ 1.35*LC1 + 1.50*snijeg + 0.60*temperatura - + 0.30*vjetar

Partial safety factors	
γ_{M0} for resistance of cross-sections	1,00
γ_{M1} for resistance to instability	1,00
γ_{M2} for resistance of net sections	1,25

Material			
Yield strength	f_y	275,0	MPa
Ultimate strength	f_u	430,0	MPa
Fabrication		Cold formed	

...:SECTION CHECK:...

The critical check is on position 0,000 m

Internal forces		Calculated	Unit
Normal force	N_{Ed}	-133,00	kN
Shear force	$V_{y,Ed}$	0,06	kN
Shear force	$V_{z,Ed}$	-0,12	kN
Torsion	T_{Ed}	-0,18	kNm
Bending moment	$M_{y,Ed}$	0,64	kNm
Bending moment	$M_{z,Ed}$	-0,21	kNm

Classification for cross-section design

Classification according to EN 1993-1-1 article 5.5.2
 Classification of Internal and Outstand parts according to EN 1993-1-1 Table 5.2 Sheet 1 & 2

Id	Type	c [mm]	t [mm]	σ_1 [kN/m ²]	σ_2 [kN/m ²]	ψ [-]	k_σ [-]	α [-]	c/t [-]	Class 1 Limit [-]	Class 2 Limit [-]	Class 3 Limit [-]	Class
1	I	75	5	7,134e+04	6,326e+04	0,89		1,00	15,00	25,88	31,43	36,57	1
3	I	75	5	6,437e+04	8,913e+04	0,72		1,00	15,00	25,88	31,43	38,88	1
5	I	75	5	9,132e+04	9,941e+04	0,92		1,00	15,00	25,88	31,43	36,15	1
7	I	75	5	9,830e+04	7,353e+04	0,75		1,00	15,00	25,88	31,43	38,49	1

Note: The Classification limits have been set according to Semi-Comp+. The cross-section is classified as Class 1

Compression check

According to EN 1993-1-1 article 6.2.4 and formula (6.9)

Cross-section area	A	1,6360e-03	m ²
Compression resistance	$N_{c,Rd}$	449,90	kN
Unity check		0,30	-

Bending moment check for M_y

According to EN 1993-1-1 article 6.2.5 and formula (6.12),(6.13)

Plastic section modulus	$W_{pl,y}$	5,1410e-05	m ³
Plastic bending moment	$M_{pl,y,Rd}$	14,14	kNm
Unity check		0,05	-

Bending moment check for M_z

According to EN 1993-1-1 article 6.2.5 and formula (6.12),(6.13)

Plastic section modulus	$W_{pl,z}$	5,1410e-05	m ³
Plastic bending moment	$M_{pl,z,Rd}$	14,14	kNm
Unity check		0,01	-

Shear check for V_y

According to EN 1993-1-1 article 6.2.6 and formula (6.17)

Shear correction factor	η	1,20	
Shear area	A_v	8,1800e-04	m ²
Plastic shear resistance for V_y	$V_{pl,y,Rd}$	129,87	kN
Unity check		0,00	-

Shear check for V_x

According to EN 1993-1-1 article 6.2.6 and formula (6.17)

Shear correction factor	η	1,20	
Shear area	A_v	8,1800e-04	m ²
Plastic shear resistance for V_x	$V_{pl,Rd}$	129,87	kN
Unity check		0,00	-

Torsion check

According to EN 1993-1-1 article 6.2.7 and formula (6.23)

Index of fibre	Fibre	1	
Total torsional moment	T_{Ed}	2,5	MPa
Elastic shear resistance	T_{Rd}	158,8	MPa
Unity check		0,02	-

Note: The unity check for torsion is lower than the limit value of 0,05. Therefore torsion is considered as insignificant and is ignored in the combined checks.

Combined bending, axial force and shear force check

According to EN 1993-1-1 article 6.2.9.1 and formula (6.41)

Design plastic moment resistance reduced due to N_{Ed}	$M_{N,y,Rd}$	12,85	kNm
Exponent of bending ratio y	α	1,84	
Design plastic moment resistance reduced due to N_{Ed}	$M_{N,z,Rd}$	12,85	kNm
Exponent of bending ratio z	β	1,84	

Unity check (6.41) = 0,00 + 0,00 = 0,00 -

Note: Since the shear forces are less than half the plastic shear resistances their effect on the moment resistances is neglected.

The member satisfies the section check.

...::STABILITY CHECK::...**Classification for member buckling design**

Decisive position for stability classification: 0,000 m

Classification according to EN 1993-1-1 article 5.5.2

Classification of Internal and Outstand parts according to EN 1993-1-1 Table 5.2 Sheet 1 & 2

Id	Type	c [mm]	t [mm]	σ_1 [kN/m ²]	σ_2 [kN/m ²]	ψ [-]	k_σ [-]	α [-]	c/t [-]	Class 1 Limit [-]	Class 2 Limit [-]	Class 3 Limit [-]	Class
1	I	75	5	7,134e+04	6,326e+04	0,88		1,00	15,00	25,88	31,43	36,57	1
3	I	75	5	6,437e+04	8,913e+04	0,72		1,00	15,00	25,88	31,43	38,88	1
5	I	75	5	9,132e+04	9,941e+04	0,92		1,00	15,00	25,88	31,43	36,15	1
7	I	75	5	9,830e+04	7,353e+04	0,75		1,00	15,00	25,88	31,43	38,49	1

Note: The Classification limits have been set according to Semi-Comp+.

The cross-section is classified as Class 1

Flexural Buckling check

According to EN 1993-1-1 article 6.3.1.1 and formula (6.46)

Buckling parameters		yy	zz	
Sway type		sway	non-sway	
System length	L	3,175	3,175	m
Buckling factor	k	1,00	0,85	
Buckling length	l_{cr}	3,175	2,709	m
Critical Euler load	N_{cr}	396,61	544,75	kN
Slenderness	λ	92,46	78,90	
Relative slenderness	λ_{rel}	1,07	0,91	
Limit slenderness	$\lambda_{rel,0}$	0,20	0,20	
Buckling curve	c	c		
Imperfection	α	0,49	0,49	
Reduction factor	χ	0,50	0,59	
Buckling resistance	$N_{b,Rd}$	226,36	267,44	kN

Flexural Buckling verification

Cross-section area	A	1,6360e-03	m ²
Buckling resistance	$N_{b,Rd}$	226,36	kN
Unity check		0,59	-

Torsional(-Flexural) Buckling check

According to EN 1993-1-1 article 6.3.1.1 and formula (6.46)

Note: The cross-section concerns a RHS section which is not susceptible to Torsional(-Flexural) Buckling.

Lateral Torsional Buckling check

According to EN 1993-1-1 article 6.3.2.1

Note: The cross-section concerns an RHS section with $h / b < 10 / \lambda_{rel,z}^2$.

This section is thus not susceptible to Lateral Torsional Buckling.

Bending and axial compression check

According to EN 1993-1-1 article 6.3.3 and formula (6.61),(6.62)

Bending and axial compression check parameters			
Interaction method		alternative method 1	
Cross-section area	A	1,6360e-03	m ²
Plastic section modulus	W _{pl,y}	5,1410e-05	m ³
Plastic section modulus	W _{pl,z}	5,1410e-05	m ³
Design compression force	N _{Ed}	133,00	kN
Design bending moment (maximum)	M _{y,Ed}	0,64	kNm
Design bending moment (maximum)	M _{z,Ed}	-0,21	kNm
Characteristic compression resistance	N _{tk}	449,90	kN
Characteristic moment resistance	M _{y,Rk}	14,14	kNm
Characteristic moment resistance	M _{z,Rk}	14,14	kNm
Reduction factor	χ _y	0,50	
Reduction factor	χ _z	0,59	
Reduction factor	χ _{LT}	1,00	
Interaction factor	k _{yy}	0,97	
Interaction factor	k _{yz}	0,55	
Interaction factor	k _{zy}	0,75	
Interaction factor	k _{zz}	0,89	

Maximum moment M_{y,Ed} is derived from beam B136 position 0,000 m.Maximum moment M_{z,Ed} is derived from beam B136 position 0,000 m.

Interaction method 1 parameters			
Critical Euler load	N _{cr,y}	396,61	kN
Critical Euler load	N _{cr,z}	544,75	kN
Elastic critical load	N _{cr,T}	108518,26	kN
Plastic section modulus	W _{pl,y}	5,1410e-05	m ³
Elastic section modulus	W _{el,y}	4,2870e-05	m ³
Plastic section modulus	W _{pl,z}	5,1410e-05	m ³
Elastic section modulus	W _{el,z}	4,2870e-05	m ³
Second moment of area	I _y	1,9293e-06	m ⁴
Second moment of area	I _z	1,9293e-06	m ⁴
Torsional constant	I _t	3,1626e-06	m ⁴
Method for equivalent moment factor C _{my,0}		Table A.2 Line 2 (General)	
Design bending moment (maximum)	M _{y,Ed}	0,64	kNm
Maximum relative deflection	δ _z	-0,7	mm
Equivalent moment factor	C _{my,0}	0,81	
Method for equivalent moment factor C _{mz,0}		Table A.2 Line 1 (Linear)	
Ratio of end moments	ψ _z	0,04	
Equivalent moment factor	C _{mz,0}	0,77	
Factor	μ _y	0,80	
Factor	μ _z	0,88	
Factor	ε _y	0,18	
Factor	α _{LT}	0,00	
Critical moment for uniform bending	M _{cr,0}	318,61	kNm
Relative slenderness	λ _{rel,0}	0,21	
Limit relative slenderness	λ _{rel,0,lim}	0,26	
Equivalent moment factor	C _{my}	0,81	
Equivalent moment factor	C _{mz}	0,77	
Equivalent moment factor	C _{myLT}	1,00	
Factor	b _{LT}	0,00	
Factor	c _{LT}	0,00	
Factor	d _{LT}	0,00	
Factor	e _{LT}	0,00	
Factor	w _y	1,20	
Factor	w _z	1,20	
Factor	η _{pl}	0,30	
Maximum relative slenderness	λ _{rel,max}	1,07	
Factor	C _{yy}	1,00	
Factor	C _{yz}	0,89	
Factor	C _{zy}	0,87	
Factor	C _{zz}	1,01	

Unity check (6.61) = 0,59 + 0,04 + 0,01 = 0,64 -

Unity check (6.62) = 0,50 + 0,03 + 0,01 = 0,54 -

The member satisfies the stability check.

4.2.5. Dijagonale – horizontalne donje

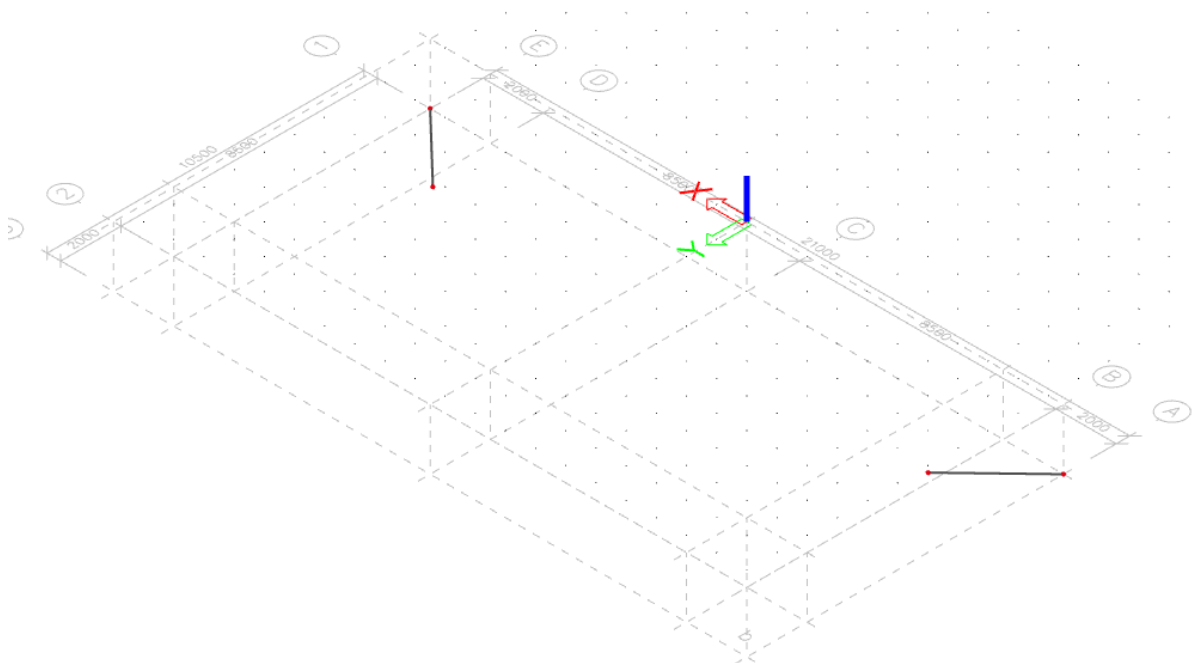

Slika 3.2.5.1. Prikaz položaja poprečnog presjeka

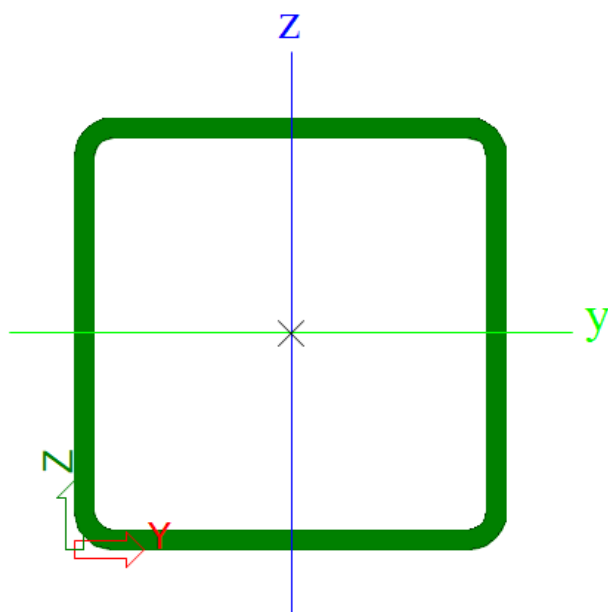

Name	Prva polja (dijagonale ...)
Type	CFRHS110X110X5
Shape type	Thin-walled
Initial shape	Available
Source and Type d...	
Source description	Rautaruukki Oyj / Stru...
Type description	Cold formed square a...
Parameters	
Material	S 275
Rectangular hollow se...	CFRHS110X110X5
Profile Library filter	All cross-sections
General	
Draw colour	Normal colour
Colour	██████████
Fabrication	cold formed
Buckling curves	
Edit buckling curves	<input type="checkbox"/>
Flexural buckling y-y	c
Flexural buckling z-z	c

Slika 3.2.5.2. Poprečni presjek dijagonala – horizontalnih donjih na prvim poljima

EC-EN 1993 Steel check ULS

Linear calculation

Combination: 1.

Coordinate system: Principal

Extreme 1D: Global

Selection: All

EN 1993-1-1 Code Check

National annex: Standard EN

Member B93 0,000 / 3,175 m CFRHS110X110X5 S 275 1. 0,87 -

Note: EN 1993-1-3 article 1.1(3) specifies that this part does not apply to cold formed CHS and RHS sections.

The default EN 1993-1-1 code check is executed instead of the EN 1993-1-3 code check.

Combination key1. / 1.35*LC1 + 1.50*snijeg + 0.60*temperatura - +
0.30*vjetar**Partial safety factors**

γ_{M0} for resistance of cross-sections	1,00
γ_{M1} for resistance to instability	1,00
γ_{M2} for resistance of net sections	1,25

Material

Yield strength	f_y	275,0	MPa
Ultimate strength	f_u	430,0	MPa
Fabrication		Cold formed	

....SECTION CHECK:....**The critical check is on position 0,000 m**

Internal forces		Calculated	Unit
Normal force	N_{Ed}	-276,37	kN
Shear force	$V_{y,Ed}$	0,25	kN
Shear force	$V_{z,Ed}$	0,01	kN
Torsion	T_{Ed}	0,14	kNm
Bending moment	$M_{y,Ed}$	-0,37	kNm
Bending moment	$M_{z,Ed}$	-0,16	kNm

Classification for cross-section design

Classification according to EN 1993-1-1 article 5.5.2

Classification of Internal and Outstand parts according to EN 1993-1-1 Table 5.2 Sheet 1 & 2

Id	Type	c [mm]	t [mm]	σ_1 [kN/m ²]	σ_2 [kN/m ²]	ψ [-]	k_{σ} [-]	α [-]	c/t [-]	Class 1 Limit [-]	Class 2 Limit [-]	Class 3 Limit [-]	Class
1	I	95	5	1,431e+05	1,390e+05	0,97		1,00	19,00	25,88	31,43	35,48	1
3	I	95	5	1,382e+05	1,288e+05	0,93		1,00	19,00	25,88	31,43	35,98	1
5	I	95	5	1,285e+05	1,326e+05	0,97		1,00	19,00	25,88	31,43	35,51	1
7	I	95	5	1,333e+05	1,428e+05	0,93		1,00	19,00	25,88	31,43	35,95	1

Note: The Classification limits have been set according to Semi-Comp+.

The cross-section is classified as Class 1

Compression check

According to EN 1993-1-1 article 6.2.4 and formula (6.9)

Cross-section area	A	2,0360e-03	m ²
Compression resistance	$N_{c,Rd}$	559,90	kN
Unity check		0,49	-

Bending moment check for M_y

According to EN 1993-1-1 article 6.2.5 and formula (6.12),(6.13)

Plastic section modulus	$W_{pl,y}$	7,9270e-05	m ³
Plastic bending moment	$M_{pl,y,Rd}$	21,80	kNm
Unity check		0,02	-

Bending moment check for M_z

According to EN 1993-1-1 article 6.2.5 and formula (6.12),(6.13)

Plastic section modulus	$W_{pl,z}$	7,9270e-05	m ³
Plastic bending moment	$M_{pl,z,Rd}$	21,80	kNm
Unity check		0,01	-

Shear check for V_y

According to EN 1993-1-1 article 6.2.6 and formula (6.17)

Shear correction factor	η	1,20	
Shear area	A_v	1,0180e-03	m ²
Plastic shear resistance for V_y	$V_{pl,y,Rd}$	161,63	kN
Unity check		0,00	-

Shear check for V_{Ed}

According to EN 1993-1-1 article 6.2.6 and formula (6.17)

Shear correction factor	η	1,20	
Shear area	A_v	1,0180e-03	m ²
Plastic shear resistance for V_{Ed}	$V_{pl,Rd}$	151,63	kN
Unity check		0,00	-

Torsion check

According to EN 1993-1-1 article 6.2.7 and formula (6.23)

Index of fibre	Fibre	1	
Total torsional moment	T_{Ed}	1,3	MPa
Elastic shear resistance	T_{Rd}	158,8	MPa
Unity check		0,01	-

Note: The unity check for torsion is lower than the limit value of 0,05. Therefore torsion is considered as insignificant and is ignored in the combined checks.

Combined bending, axial force and shear force check

According to EN 1993-1-1 article 6.2.9.1 and formula (6.41)

Design plastic moment resistance reduced due to N_{Ed}	$M_{N_y,Rd}$	14,33	kNm
Exponent of bending ratio y	α	2,29	
Design plastic moment resistance reduced due to N_{Ed}	$M_{N_z,Rd}$	14,33	kNm
Exponent of bending ratio z	β	2,29	

Unity check (6.41) = 0,00 + 0,00 = 0,00 -

Note: Since the shear forces are less than half the plastic shear resistances their effect on the moment resistances is neglected.

The member satisfies the section check.

...::STABILITY CHECK::...

Classification for member buckling design

Decisive position for stability classification: 3,175 m

Classification according to EN 1993-1-1 article 5.5.2

Classification of Internal and Outstand parts according to EN 1993-1-1 Table 5.2 Sheet 1 & 2

Id	Type	c [mm]	t [mm]	σ_1 [kN/m ²]	σ_2 [kN/m ²]	ψ [-]	k_{σ} [-]	α [-]	c/t [-]	Class 1 Limit [-]	Class 2 Limit [-]	Class 3 Limit [-]	Class
1	I	95	5	1,475e+05	1,638e+05	0,90		1,00	19,00	25,88	31,43	36,39	1
3	I	95	5	1,628e+05	1,269e+05	0,78		1,00	19,00	25,88	31,43	38,04	1
5	I	95	5	1,241e+05	1,078e+05	0,87		1,00	19,00	25,88	31,43	36,81	1
7	I	95	5	1,088e+05	1,447e+05	0,75		1,00	19,00	25,88	31,43	38,44	1

Note: The Classification limits have been set according to Semi-Comp+.

The cross-section is classified as Class 1

Flexural Buckling check

According to EN 1993-1-1 article 6.3.1.1 and formula (6.46)

Buckling parameters		yy	zz	
Sway type		sway	non-sway	
System length	L	3,175	3,175	m
Buckling factor	k	1,00	1,00	
Buckling length	l_{cr}	3,175	3,175	m
Critical Euler load	N_{cr}	756,40	756,40	kN
Slenderness	λ	74,69	74,69	
Relative slenderness	λ_{rel}	0,86	0,86	
Limit slenderness	$\lambda_{rel,0}$	0,20	0,20	
Buckling curve	c	c	c	
Imperfection	α	0,49	0,49	
Reduction factor	χ	0,62	0,62	
Buckling resistance	$N_{b,Rd}$	349,58	349,58	kN

Flexural Buckling verification

Cross-section area	A	2,0360e-03	m ²
Buckling resistance	$N_{b,Rd}$	349,58	kN
Unity check		0,79	-

Torsional(-Flexural) Buckling check

According to EN 1993-1-1 article 6.3.1.1 and formula (6.46)

Note: The cross-section concerns a RHS section which is not susceptible to Torsional(-Flexural) Buckling.

Lateral Torsional Buckling check

According to EN 1993-1-1 article 6.3.2.1

Note: The cross-section concerns an RHS section with $t_h / b < 10 / \lambda_{rel,z}^2$.

This section is thus not susceptible to Lateral Torsional Buckling.

Bending and axial compression check

According to EN 1993-1-1 article 6.3.3 and formula (6.61),(6.62)

Bending and axial compression check parameters			
Interaction method		alternative method 1	
Cross-section area	A	2,0360e-03	m ²
Plastic section modulus	W _{pl,y}	7,9270e-05	m ³
Plastic section modulus	W _{pl,z}	7,9270e-05	m ³
Design compression force	N _{Ed}	276,37	kN
Design bending moment (maximum)	M _{y,Ed}	-1,39	kNm
Design bending moment (maximum)	M _{z,Ed}	0,63	kNm
Characteristic compression resistance	N _{tk}	559,90	kN
Characteristic moment resistance	M _{y,Rk}	21,80	kNm
Characteristic moment resistance	M _{z,Rk}	21,80	kNm
Reduction factor	χ _y	0,62	
Reduction factor	χ _z	0,62	
Reduction factor	χ _{LT}	1,00	
Interaction factor	k _{yy}	1,06	
Interaction factor	k _{yz}	0,51	
Interaction factor	k _{zy}	0,74	
Interaction factor	k _{zz}	0,78	

Maximum moment M_{y,Ed} is derived from beam B93 position 3,175 m.Maximum moment M_{z,Ed} is derived from beam B93 position 3,175 m.

Interaction method 1 parameters			
Critical Euler load	N _{cr,y}	756,40	kN
Critical Euler load	N _{cr,z}	756,40	kN
Elastic critical load	N _{cr,T}	133029,08	kN
Plastic section modulus	W _{pl,y}	7,9270e-05	m ³
Elastic section modulus	W _{el,y}	6,6900e-05	m ³
Plastic section modulus	W _{pl,z}	7,9270e-05	m ³
Elastic section modulus	W _{el,z}	6,6900e-05	m ³
Second moment of area	I _y	3,6795e-06	m ⁴
Second moment of area	I _z	3,6795e-06	m ⁴
Torsional constant	I _t	5,9360e-06	m ⁴
Method for equivalent moment factor C _{my,0}		Table A.2 Line 2 (General)	
Design bending moment (maximum)	M _{y,Ed}	-1,39	kNm
Maximum relative deflection	δ _L	1,1	mm
Equivalent moment factor	C _{my,0}	0,85	
Method for equivalent moment factor C _{mz,0}		Table A.2 Line 1 (Linear)	
Ratio of end moments	ψ _z	-0,25	
Equivalent moment factor	C _{mz,0}	0,66	
Factor	μ _y	0,82	
Factor	μ _z	0,82	
Factor	ε _y	0,15	
Factor	α _{LT}	0,00	
Critical moment for uniform bending	M _{cr,0}	603,07	kNm
Relative slenderness	λ _{rel,0}	0,19	
Limit relative slenderness	λ _{rel,0,lim}	0,25	
Equivalent moment factor	C _{my}	0,85	
Equivalent moment factor	C _{mz}	0,66	
Equivalent moment factor	C _{rrLT}	1,00	
Factor	b _{LT}	0,00	
Factor	c _{LT}	0,00	
Factor	d _{LT}	0,00	
Factor	e _{LT}	0,00	
Factor	w _y	1,18	
Factor	w _z	1,18	
Factor	η _{pl}	0,49	
Maximum relative slenderness	λ _{rel,max}	0,86	
Factor	C _{yy}	1,04	
Factor	C _{yz}	1,01	
Factor	C _{zy}	0,89	
Factor	C _{zz}	1,10	

Unity check (6.61) = 0,79 + 0,07 + 0,01 = 0,87 -

Unity check (6.62) = 0,79 + 0,05 + 0,02 = 0,86 -

The member satisfies the stability check.

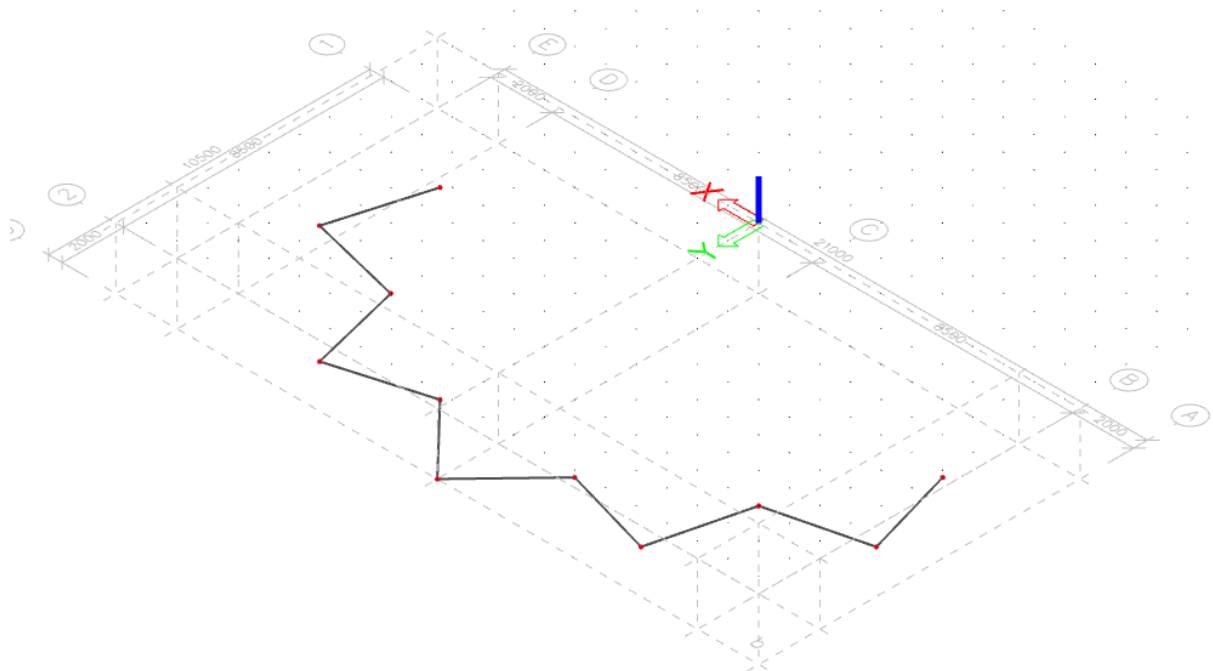

Slika 3.2.5.3. Prikaz položaja poprečnog presjeka

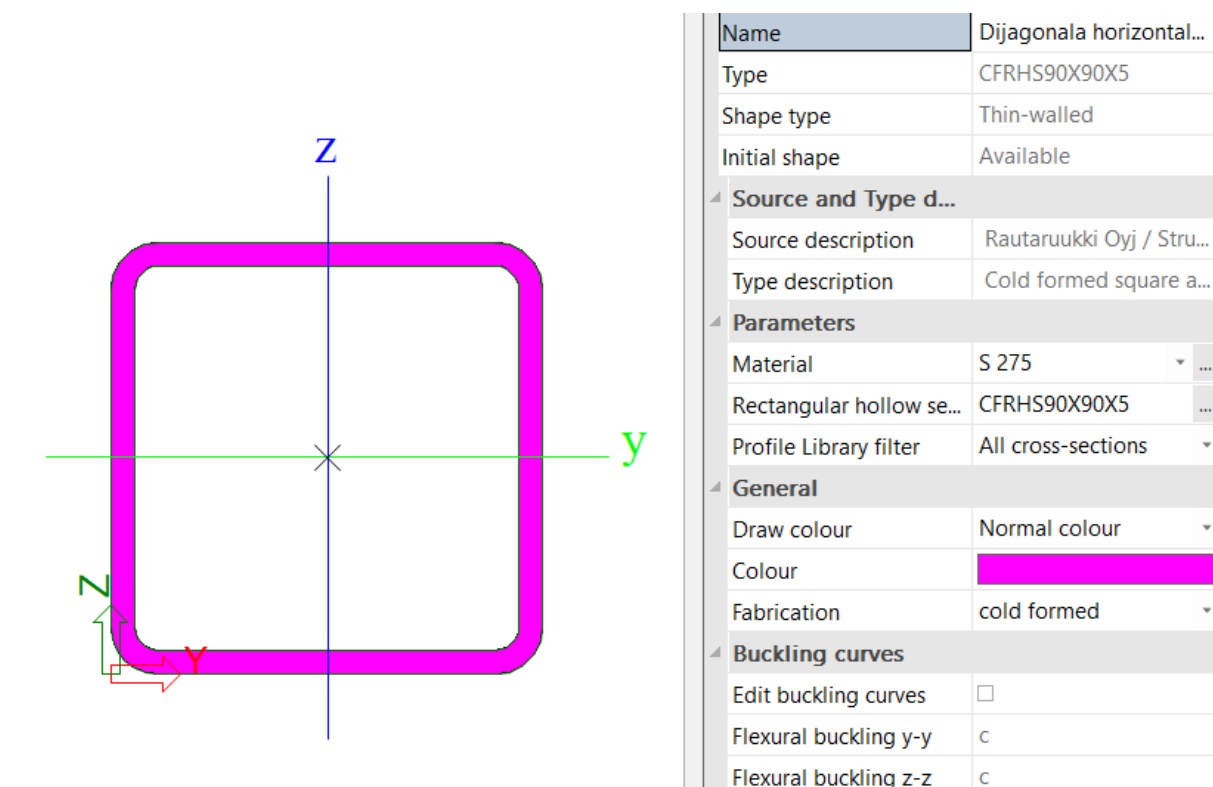

Slika 3.2.5.4. Poprečni presjek dijagonala - horizontalnih donjih na ostalim poljima

EC-EN 1993 Steel check ULS

Linear calculation

Combination: 1.

Coordinate system: Principal

Extreme 1D: Global

Selection: All

EN 1993-1-1 Code Check

National annex: Standard EN

Member B96 0,000 / 3,175 m **CFRHS90X90X5** **S 275** **1.** **0,65 -**

Note: EN 1993-1-3 article 1.1(3) specifies that this part does not apply to cold formed CHS and RHS sections.
The default EN 1993-1-1 code check is executed instead of the EN 1993-1-3 code check.

Combination key

1. / 1.35*LC1 + 1.50*snijeg + 0.60*temperatura - + 0.30*vjetar

Partial safety factors

γ_{M0} for resistance of cross-sections	1,00
γ_{M1} for resistance to instability	1,00
γ_{M2} for resistance of net sections	1,25

Material

Yield strength	f_y	275,0	MPa
Ultimate strength	f_u	430,0	MPa
Fabrication		Cold formed	

...:SECTION CHECK:...The critical check is on position **0,000 m**

Internal forces		Calculated	Unit
Normal force	N_{Ed}	-135,48	kN
Shear force	$V_{y,Ed}$	-0,01	kN
Shear force	$V_{z,Ed}$	0,71	kN
Torsion	T_{Ed}	0,09	kNm
Bending moment	$M_{y,Ed}$	-0,85	kNm
Bending moment	$M_{z,Ed}$	0,13	kNm

Classification for cross-section design

Classification: according to EN 1993-1-1 article 5.5.2

Classification of Internal and Outstand parts according to EN 1993-1-1 Table 5.2 Sheet 1 & 2

Id	Type	c [mm]	t [mm]	σ_1 [kN/m ²]	σ_2 [kN/m ²]	ψ [-]	k_{σ} [-]	α [-]	c/t [-]	Class 1 Limit [-]	Class 2 Limit [-]	Class 3 Limit [-]	Class
1	I	75	5	9,909e+04	1,042e+05	0,95		1,00	15,00	25,88	31,43	35,73	1
3	I	75	5	1,023e+05	6,914e+04	0,68		1,00	15,00	25,88	31,43	39,58	1
5	I	75	5	6,659e+04	6,152e+04	0,92		1,00	15,00	25,88	31,43	36,08	1
7	I	75	5	6,339e+04	9,655e+04	0,66		1,00	15,00	25,88	31,43	39,88	1

Note: The Classification limits have been set according to Semi-Comp+.
The cross-section is classified as Class 1

Compression check

According to EN 1993-1-1 article 6.2.4 and formula (6.9)

Cross-section area	A	1,6360e-03	m ²
Compression resistance	$N_{c,Rd}$	449,90	kN
Unity check		0,30	-

Bending moment check for M_y

According to EN 1993-1-1 article 6.2.5 and formula (6.12),(6.13)

Plastic section modulus	$W_{pl,y}$	5,1410e-05	m ³
Plastic bending moment	$M_{pl,y,Rd}$	14,14	kNm
Unity check		0,06	-

Bending moment check for M_z

According to EN 1993-1-1 article 6.2.5 and formula (6.12),(6.13)

Plastic section modulus	$W_{pl,z}$	5,1410e-05	m ³
Plastic bending moment	$M_{pl,z,Rd}$	14,14	kNm
Unity check		0,01	-

Shear check for V_y

According to EN 1993-1-1 article 6.2.6 and formula (6.17)

Shear correction factor	η	1,20	
Shear area	A_v	8,1800e-04	m ²
Plastic shear resistance for V_y	$V_{pl,y,Rd}$	129,67	kN
Unity check		0,00	-

Shear check for V_x

According to EN 1993-1-1 article 6.2.6 and formula (6.17)

Shear correction factor	η	1,20	
Shear area	A_v	8,1800e-04	m ²
Plastic shear resistance for V_x	$V_{pl,Rd}$	129,87	kN
Unity check		0,01	-

Torsion check

According to EN 1993-1-1 article 6.2.7 and formula (6.23)

Index of fibre	Fibre	1	
Total torsional moment	T_{Ed}	1,2	MPa
Elastic shear resistance	T_{Rd}	158,8	MPa
Unity check		0,01	-

Note: The unity check for torsion is lower than the limit value of 0,05. Therefore torsion is considered as insignificant and is ignored in the combined checks.

Combined bending, axial force and shear force check

According to EN 1993-1-1 article 6.2.9.1 and formula (6.41)

Design plastic moment resistance reduced due to N_{Ed}	$M_{N,y,Rd}$	12,75	kNm
Exponent of bending ratio y	α	1,85	
Design plastic moment resistance reduced due to N_{Ed}	$M_{N,z,Rd}$	12,75	kNm
Exponent of bending ratio z	β	1,85	

Unity check (6.41) = 0,01 + 0,00 = 0,01 -

Note: Since the shear forces are less than half the plastic shear resistances their effect on the moment resistances is neglected.

The member satisfies the section check.

...::STABILITY CHECK::...

Classification for member buckling design

Decisive position for stability classification: 0,000 m

Classification according to EN 1993-1-1 article 5.5.2

Classification of Internal and Outstand parts according to EN 1993-1-1 Table 5.2 Sheet 1 & 2

Id	Type	c [mm]	t [mm]	σ_1 [kN/m ²]	σ_2 [kN/m ²]	ψ [-]	k_α [-]	α [-]	c/t [-]	Class 1 Limit [-]	Class 2 Limit [-]	Class 3 Limit [-]	Class
1	I	75	5	9,909e+04	1,042e+05	0,95		1,00	15,00	25,88	31,43	35,73	1
3	I	75	5	1,023e+05	6,914e+04	0,68		1,00	15,00	25,88	31,43	39,58	1
5	I	75	5	6,659e+04	6,152e+04	0,92		1,00	15,00	25,88	31,43	36,08	1
7	I	75	5	6,339e+04	9,655e+04	0,66		1,00	15,00	25,88	31,43	39,88	1

Note: The Classification limits have been set according to Semi-Comp+.

The cross-section is classified as Class 1

Flexural Buckling check

According to EN 1993-1-1 article 6.3.1.1 and formula (6.46)

Buckling parameters		yy	zz	
Sway type		sway	non-sway	
System length	L	3,175	3,175	m
Buckling factor	k	1,00	0,79	
Buckling length	l_{cr}	3,175	2,502	m
Critical Euler load	N_{cr}	396,61	639,00	kN
Slenderness	λ	92,46	72,85	
Relative slenderness	λ_{rel}	1,07	0,84	
Limit slenderness	$\lambda_{rel,D}$	0,20	0,20	
Buckling curve	c	c		
Imperfection	α	0,49	0,49	
Reduction factor	χ	0,50	0,64	
Buckling resistance	$N_{b,Rd}$	226,36	286,88	kN

Flexural Buckling verification

Cross-section area	A	1,6360e-03	m ²
Buckling resistance	$N_{b,Rd}$	226,36	kN
Unity check		0,60	-

Torsional(-Flexural) Buckling check

According to EN 1993-1-1 article 6.3.1.1 and formula (6.46)

Note: The cross-section concerns a RHS section which is not susceptible to Torsional(-Flexural) Buckling.

Latera! Torsional Buckling check

According to EN 1993-1-1 article 6.3.2.1

Note: The cross-section concerns an RHS section with $t_h / b < 10 / \lambda_{rel,z}^2$. This section is thus not susceptible to Lateral Torsional Buckling.

Bending and axial compression check

According to EN 1993-1-1 article 6.3.3 and formula (6.61),(6.62)

Bending and axial compression check parameters			
Interaction method		alternative method 1	
Cross-section area	A	1,6360e-03	m ²
Plastic section modulus	$W_{pl,y}$	5,1410e-05	m ³
Plastic section modulus	$W_{pl,z}$	5,1410e-05	m ³
Design compression force	N_{Ed}	135,48	kN
Design bending moment (maximum)	$M_{y,Ed}$	-0,85	kNm
Design bending moment (maximum)	$M_{z,Ed}$	0,13	kNm
Characteristic compression resistance	N_{Rk}	449,90	kN
Characteristic moment resistance	$M_{y,Rk}$	14,14	kNm
Characteristic moment resistance	$M_{z,Rk}$	14,14	kNm
Reduction factor	χ_y	0,50	
Reduction factor	χ_z	0,64	
Reduction factor	χ_{LT}	1,00	
Interaction factor	k_{yy}	0,82	
Interaction factor	k_{yz}	0,74	
Interaction factor	k_{zy}	0,63	
Interaction factor	k_{zz}	1,14	

Maximum moment $M_{y,Ed}$ is derived from beam B96 position 0,000 m.Maximum moment $M_{z,Ed}$ is derived from beam B96 position 0,000 m.

Interaction method 1 parameters			
Critical Euler load	$N_{cr,y}$	396,61	kN
Critical Euler load	$N_{cr,z}$	639,00	kN
Elastic critical load	$N_{cr,T}$	108518,26	kN
Plastic section modulus	$W_{pl,y}$	5,1410e-05	m ³
Elastic section modulus	$W_{el,y}$	4,2870e-05	m ³
Plastic section modulus	$W_{pl,z}$	5,1410e-05	m ³
Elastic section modulus	$W_{el,z}$	4,2870e-05	m ³
Second moment of area	I_y	1,9293e-06	m ⁴
Second moment of area	I_z	1,9293e-06	m ⁴
Torsional constant	I_t	3,1626e-06	m ⁴
Method for equivalent moment factor $C_{my,0}$		Table A.2 Line 2 (General)	
Design bending moment (maximum)	$M_{y,Ed}$	-0,85	kNm
Maximum relative deflection	δ_z	-0,3	mm
Equivalent moment factor	$C_{my,0}$	0,70	
Method for equivalent moment factor $C_{mz,0}$		Table A.2 Line 1 (Linear)	
Ratio of end moments	ψ_z	0,64	
Equivalent moment factor	$C_{mz,0}$	0,95	
Factor	μ_y	0,80	
Factor	μ_z	0,91	
Factor	ϵ_y	0,24	
Factor	$\beta_{1,T}$	0,00	
Critical moment for uniform bending	$M_{cr,0}$	318,61	kNm
Relative slenderness	$\lambda_{rel,0}$	0,21	
Limit relative slenderness	$\lambda_{rel,0,lim}$	0,33	
Equivalent moment factor	C_{my}	0,70	
Equivalent moment factor	C_{mz}	0,95	
Equivalent moment factor	C_{yLT}	1,00	
Factor	$b_{1,T}$	0,00	
Factor	c_{LT}	0,00	
Factor	d_{LT}	0,00	
Factor	e_{LT}	0,00	
Factor	w_y	1,20	
Factor	w_z	1,20	
Factor	η_{pl}	0,30	
Maximum relative slenderness	$\lambda_{rel,max}$	1,07	
Factor	C_{yy}	1,03	
Factor	C_{yz}	0,77	
Factor	C_{zy}	0,93	
Factor	C_{zz}	0,96	

Unity check (6.61) = 0,60 + 0,05 + 0,01 = 0,65 -

Unity check (6.62) = 0,47 + 0,04 + 0,01 = 0,52 -

The member satisfies the stability check.

4.2.6. Dijagonala – vertikalna

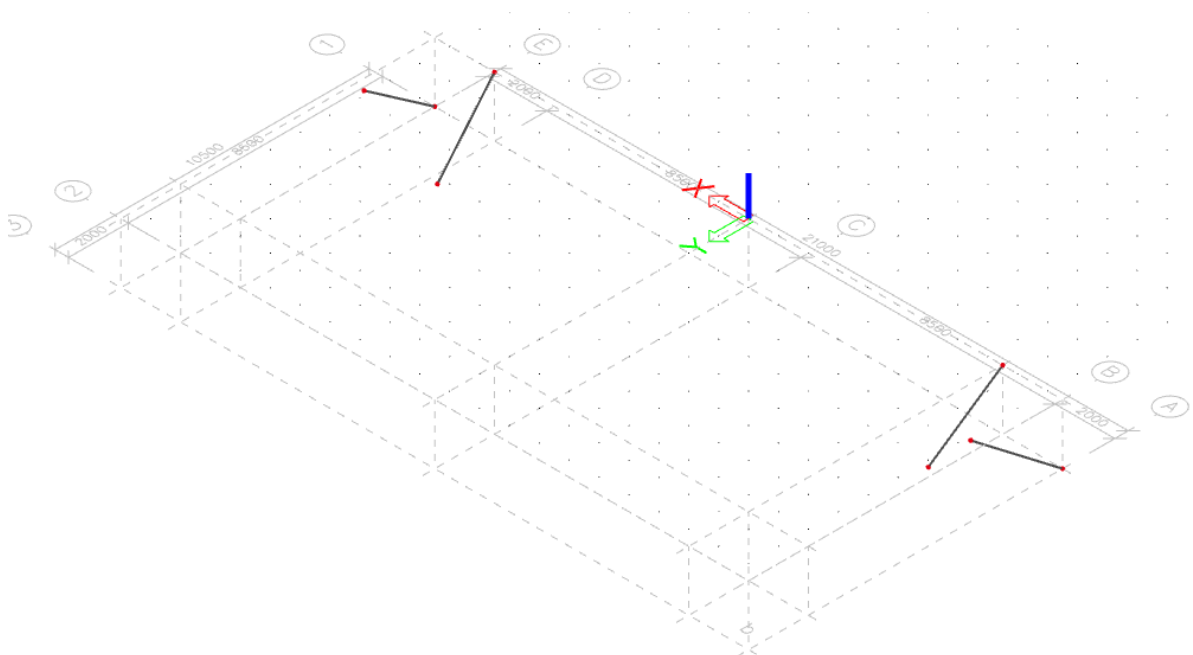

Slika 3.2.6.1. Prikaz položaja poprečnog presjeka

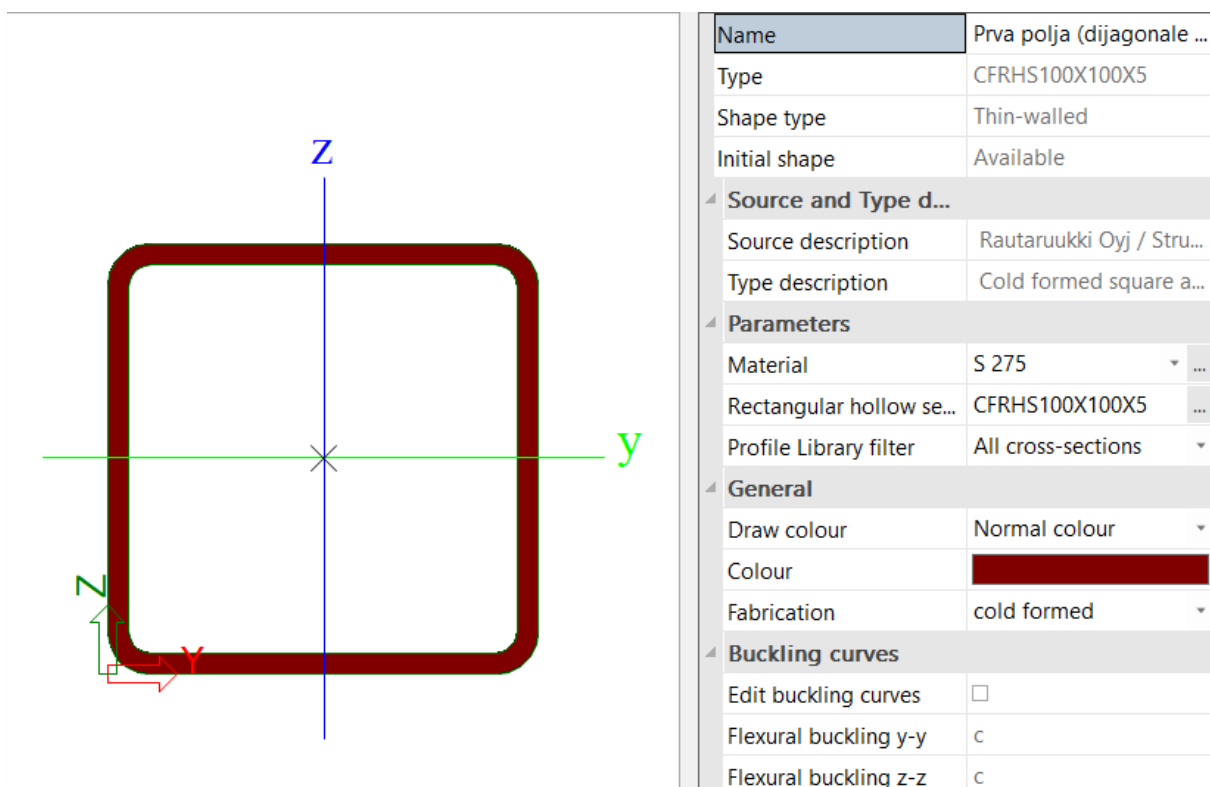

Slika 3.2.6.2. Poprečni presjek dijagonala – vertikalnih na prvim poljima

EC-EN 1993 Steel check ULS

Linear calculation

Combination: 1.

Coordinate system: Principal

Extreme 1D: Global

Selection: All

EN 1993-1-1 Code Check

National annex: Standard EN

Member B74 0,000 / 3,393 m CFRHS100X100X5 S 275 1. 0,91 -

Note: EN 1993-1-3 article 1.1(3) specifies that this part does not apply to cold formed CHS and RHS sections.
The default EN 1993-1-1 code check is executed instead of the EN 1993-1-3 code check.

Combination key

1. / 1.35*LC1 + 1.50*snijeg + 0.60*temperatura - +
0.30*vjetar

Partial safety factors

γ_{M0} for resistance of cross-sections	1,00
γ_{M1} for resistance to instability	1,00
γ_{M2} for resistance of net sections	1,25

Material

Yield strength	f_y	275,0	MPa
Ultimate strength	f_u	430,0	MPa
Fabrication		Cold formed	

...:SECTION CHECK:...

The critical check is on position 0,000 m

Internal forces		Calculated	Unit
Normal force	N_{Ed}	-217,53	kN
Shear force	$V_{y,Ed}$	0,21	kN
Shear force	$V_{z,Ed}$	0,54	kN
Torsion	T_{Ed}	-0,20	kNm
Bending moment	$M_{y,Ed}$	-1,18	kNm
Bending moment	$M_{z,Ed}$	-0,92	kNm

Classification for cross-section design

Classification: according to EN 1993-1-1 article 5.5.2

Classification of Internal and Outstand parts according to EN 1993-1-1 Table 5.2 Sheet 1 & 2

Id	Type	c [mm]	t [mm]	σ_1 [kN/m ²]	σ_2 [kN/m ²]	ψ [-]	k_{σ} [-]	α [-]	c/t [-]	Class 1 Limit [-]	Class 2 Limit [-]	Class 3 Limit [-]	Class
1	I	85	5	1,536e+05	1,249e+05	0,81		1,00	17,00	25,88	31,43	37,56	1
3	I	85	5	1,210e+05	8,393e+04	0,69		1,00	17,00	25,88	31,43	39,31	1
5	I	85	5	8,344e+04	1,122e+05	0,74		1,00	17,00	25,88	31,43	38,55	1
7	I	85	5	1,160e+05	1,531e+05	0,76		1,00	17,00	25,88	31,43	38,35	1

Note: The Classification limits have been set according to Semi-Comp+.
The cross-section is classified as Class 1

Compression check

According to EN 1993-1-1 article 6.2.4 and formula (6.9)

Cross-section area	A	1,8360e-03	m ²
Compression resistance	$N_{c,Rd}$	504,90	kN
Unity check		0,43	-

Bending moment check for M_y

According to EN 1993-1-1 article 6.2.5 and formula (6.12),(6.13)

Plastic section modulus	$W_{pl,y}$	6,4590e-05	m ³
Plastic bending moment	$M_{pl,y,Rd}$	17,76	kNm
Unity check		0,07	-

Bending moment check for M_z

According to EN 1993-1-1 article 6.2.5 and formula (6.12),(6.13)

Plastic section modulus	$W_{pl,z}$	6,4590e-05	m ³
Plastic bending moment	$M_{pl,z,Rd}$	17,76	kNm
Unity check		0,05	-

Shear check for V_y

According to EN 1993-1-1 article 6.2.6 and formula (6.17)

Shear correction factor	η	1,20	
Shear area	A_v	9,1800e-04	m ²
Plastic shear resistance for V_y	$V_{pl,y,Rd}$	145,75	kN
Unity check		0,00	-

Shear check for V_z

According to EN 1993-1-1 article 6.2.6 and formula (6.17)

Shear correction factor	η	1,20	
Shear area	A_v	9,1800e-04	m ²
Plastic shear resistance for V_z	$V_{pl,Rd}$	145,75	kN
Unity check		0,00	-

Torsion check

According to EN 1993-1-1 article 6.2.7 and formula (6.23)

Index of fibre	Fibre	I	
Total torsional moment	T_{Ed}	2,2	MPa
Elastic shear resistance	T_{Rd}	158,8	MPa
Unity check		0,01	-

Note: The unity check for torsion is lower than the limit value of 0,05. Therefore torsion is considered as insignificant and is ignored in the combined checks.

Combined bending, axial force and shear force check

According to EN 1993-1-1 article 6.2.9.1 and formula (6.41)

Design plastic moment resistance reduced due to N_{Ed}	$M_{N_y,Rd}$	13,09	kNm
Exponent of bending ratio y	α	2,10	
Design plastic moment resistance reduced due to N_{Ed}	$M_{N_z,Rd}$	13,09	kNm
Exponent of bending ratio z	β	2,10	

Unity check (6.41) = 0,01 + 0,00 = 0,01 -

Note: Since the shear forces are less than half the plastic shear resistances their effect on the moment resistances is neglected.

The member satisfies the section check.

...::STABILITY CHECK::...

Classification for member buckling design

Decisive position for stability classification: 0,000 m

Classification according to EN 1993-1-1 article 5.5.2

Classification of Internal and Outstand parts according to EN 1993-1-1 Table 5.2 Sheet 1 & 2

Id	Type	c [mm]	t [mm]	σ_1 [kN/m ²]	σ_2 [kN/m ²]	ψ [-]	k_{σ} [-]	α [-]	c/t [-]	Class 1 Limit [-]	Class 2 Limit [-]	Class 3 Limit [-]	Class
1	I	85	5	1,536e+05	1,249e+05	0,81	1,00	17,00	17,00	25,88	31,43	37,56	1
3	I	85	5	1,210e+05	8,393e+04	0,69	1,00	17,00	17,00	25,88	31,43	39,31	1
5	I	85	5	8,344e+04	1,122e+05	0,74	1,00	17,00	17,00	25,88	31,43	38,55	1
7	I	85	5	1,160e+05	1,531e+05	0,76	1,00	17,00	17,00	25,88	31,43	36,35	1

Note: The Classification limits have been set according to Semi-Comp+. The cross-section is classified as Class 1

Flexural Buckling check

According to EN 1993-1-1 article 6.3.1.1 and formula (6.46)

Buckling parameters		yy	zz	
Sway type		sway	non-sway	
System length	L	3,393	3,393	m
Buckling factor	k	1,00	0,70	
Buckling length	l_{cr}	3,393	2,375	m
Critical Euler load	N_{cr}	488,03	995,98	kN
Slenderness	λ	88,30	61,81	
Relative slenderness	λ_{rel}	1,02	0,71	
Limit slenderness	$\lambda_{rel,0}$	0,20	0,20	
Buckling curve		c	c	
Imperfection	α	0,49	0,49	
Reduction factor	χ	0,53	0,72	
Buckling resistance	$N_{b,Rd}$	267,63	362,14	kN

Flexural Buckling verification

Cross-section area	A	1,8360e-03	m ²
Buckling resistance	$N_{b,Rd}$	267,63	kN
Unity check		0,81	-

Torsional(-Flexural) Buckling check

According to EN 1993-1-1 article 6.3.1.1 and formula (6.46)

Note: The cross-section concerns a RHS section which is not susceptible to Torsional(-Flexural) Buckling.

Lateral Torsional Buckling check

According to EN 1993-1-1 article 6.3.2.1

Note: The cross-section concerns an RHS section with $h/b < 10 / \lambda_{rel,z}^2$. This section is thus not susceptible to Lateral Torsional Buckling.

Bending and axial compression check

According to EN 1993-1-1 article 6.3.3 and formula (6.61),(6.62)

Bending and axial compression check parameters			
Interaction method		alternative method 1	
Cross-section area	A	1,8360e-03	m ²
Plastic section modulus	W _{pl,y}	6,4590e-05	m ³
Plastic section modulus	W _{pl,z}	6,4590e-05	m ³
Design compression force	N _{Ed}	217,53	kN
Design bending moment (maximum)	M _{y,Ed}	-1,18	kNm
Design bending moment (maximum)	M _{z,Ed}	-0,92	kNm
Characteristic compression resistance	N _{sk}	504,90	kN
Characteristic moment resistance	M _{y,Rk}	17,76	kNm
Characteristic moment resistance	M _{z,Rk}	17,76	kNm
Reduction factor	χ _y	0,53	
Reduction factor	χ _z	0,72	
Reduction factor	χ _{LT}	1,00	
Interaction factor	k _{yy}	1,03	
Interaction factor	k _{yz}	0,56	
Interaction factor	k _{zy}	0,95	
Interaction factor	k _{zz}	0,98	

Maximum moment M_{y,Ed} is derived from beam B74 position 0,000 m.Maximum moment M_{z,Ed} is derived from beam B74 position 0,000 m.

Interaction method 1 parameters			
Critical Euler load	N _{cr,y}	488,03	kN
Critical Euler load	N _{cr,z}	995,98	kN
Elastic critical load	N _{cr,T}	120736,71	kN
Plastic section modulus	W _{pl,y}	6,4590e-05	m ³
Elastic section modulus	W _{el,y}	5,4220e-05	m ³
Plastic section modulus	W _{pl,z}	6,4590e-05	m ³
Elastic section modulus	W _{el,z}	5,4220e-05	m ³
Second moment of area	I _y	2,7110e-06	m ⁴
Second moment of area	I _z	2,7110e-06	m ⁴
Torsional constant	I _t	4,4052e-06	m ⁴
Method for equivalent moment factor C _{my,0}		Table A.2 Line 2 (General)	
Design bending moment (maximum)	M _{y,Ed}	-1,18	kNm
Maximum relative deflection	δ _s	1,3	mm
Equivalent moment factor	C _{my,0}	0,80	
Method for equivalent moment factor C _{mz,0}		Table A.2 Line 1 (Linear)	
Ratio of end moments	ψ _z	0,23	
Equivalent moment factor	C _{mz,0}	0,83	
Factor	μ _F	0,73	
Factor	μ _E	0,93	
Factor	ε _y	0,18	
Factor	α _{LT}	0,00	
Critical moment for uniform bending	M _{cr,0}	417,14	kNm
Relative slenderness	λ _{rel,0}	0,21	
Limit relative slenderness	λ _{rel,0,lim}	0,27	
Equivalent moment factor	C _{my}	0,80	
Equivalent moment factor	C _{mz}	0,83	
Equivalent moment factor	C _{myLT}	1,00	
Factor	b _{LT}	0,00	
Factor	c _{LT}	0,00	
Factor	d _{LT}	0,00	
Factor	e _{LT}	0,00	
Factor	w _y	1,19	
Factor	w _z	1,19	
Factor	η _{pl}	0,43	
Maximum relative slenderness	λ _{rel,max}	1,02	
Factor	C _{yy}	1,02	
Factor	C _{yz}	0,82	
Factor	C _{zy}	0,85	
Factor	C _{zz}	1,01	

Unity check (6.61) = 0,81 + 0,07 + 0,03 = 0,91 -

Unity check (6.62) = 0,60 + 0,06 + 0,05 = 0,71 -

The member satisfies the stability check.

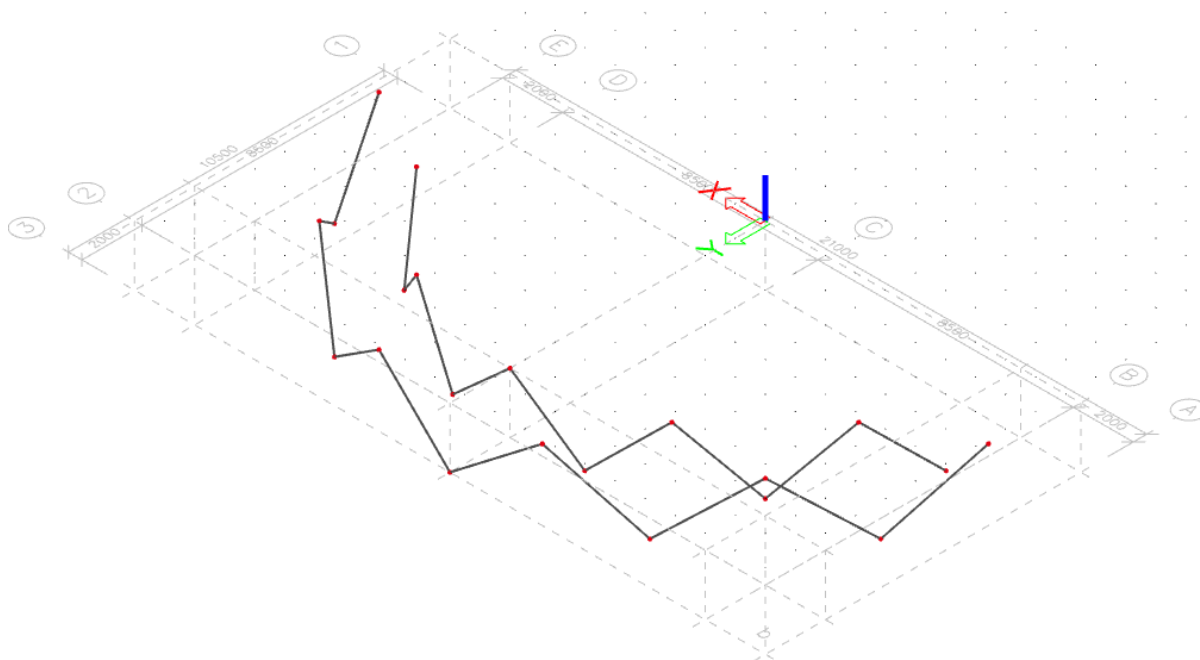

Slika 3.2.6.3. Prikaz položaja poprečnog presjeka

Name	Dijagonala vertikalna (...)
Type	CFRHS90X90X5
Shape type	Thin-walled
Initial shape	Available
Source and Type d...	
Source description	Rautaruukki Oyj / Stru...
Type description	Cold formed square a...
Parameters	
Material	S 275
Rectangular hollow se...	CFRHS90X90X5
Profile Library filter	All cross-sections
General	
Draw colour	Normal colour
Colour	
Fabrication	cold formed
Buckling curves	
Edit buckling curves	<input type="checkbox"/>
Flexural buckling y-y	c
Flexural buckling z-z	c

Slika 3.2.6.4. Poprečni presjek dijagonala – vertikalnih na ostalim poljima

EC-EN 1993 Steel check ULS

Linear calculation
 Combination: 1.
 Coordinate system: Principal
 Extreme 1D: Global
 Selection: All

EN 1993-1-1 Code Check
 National annex: Standard EN

Member B81	0,000 / 2,987 m	CFRHS90X90X5	S 275	1.	0,78 -
-------------------	------------------------	---------------------	--------------	-----------	---------------

Note: EN 1993-1-3 article 1.1(3) specifies that this part does not apply to cold formed CHS and RHS sections. The default EN 1993-1-1 code check is executed instead of the EN 1993-1-3 code check.

Combination key	
1.	/ 1.35*LC1 + 1.50*snijeg + 0.60*temperatura - + 0.30*vjetar

Partial safety factors	
γ_{M0} for resistance of cross-sections	1,00
γ_{M1} for resistance to instability	1,00
γ_{M2} for resistance of net sections	1,25

Material			
Yield strength	f_y	275,0	MPa
Ultimate strength	f_u	430,0	MPa
Fabrication		Cold formed	

...:SECTION CHECK:...:

The critical check is on position 0,000 m

Internal forces		Calculated	Unit
Normal force	N_{Ed}	-172,30	kN
Shear force	$V_{y,Ed}$	0,71	kN
Shear force	$V_{z,Ed}$	0,29	kN
Torsion	T_{Ed}	-0,29	kNm
Bending moment	$M_{y,Ed}$	-0,40	kNm
Bending moment	$M_{z,Ed}$	-1,54	kNm

Classification for cross-section design

Classification according to EN 1993-1-1 article 5.5.2
 Classification of Internal and Outstand parts according to EN 1993-1-1 Table 5.2 Sheet 1 & 2

Id	Type	c [mm]	t [mm]	σ_1 [kN/m ²]	σ_2 [kN/m ²]	ψ [-]	k_{σ} [-]	α [-]	c/t [-]	Class 1 Limit [-]	Class 2 Limit [-]	Class 3 Limit [-]	Class
1	I	75	5	1,440e+05	8,436e+04	0,59		1,00	15,00	25,88	31,43	41,03	1
3	I	75	5	7,934e+04	6,373e+04	0,80		1,00	15,00	25,88	31,43	37,70	1
5	I	75	5	6,667e+04	1,264e+05	0,53		1,00	15,00	25,88	31,43	42,01	1
7	I	75	5	1,314e+05	1,470e+05	0,89		1,00	15,00	25,88	31,43	36,47	1

Note: The Classification limits have been set according to Semi-Comp+. The cross-section is classified as Class 1

Compression check

According to EN 1993-1-1 article 6.2.4 and formula (6.9)

Cross-section area	A	1,6360e-03	m ²
Compression resistance	$N_{c,Rd}$	449,90	kN
Unity check		0,38	-

Bending moment check for M_y

According to EN 1993-1-1 article 6.2.5 and formula (6.12),(6.13)

Plastic section modulus	$W_{pl,y}$	5,1410e-05	m ³
Plastic bending moment	$M_{pl,y,Rd}$	14,14	kNm
Unity check		0,03	-

Bending moment check for M_z

According to EN 1993-1-1 article 6.2.5 and formula (6.12),(6.13)

Plastic section modulus	$W_{pl,z}$	5,1410e-05	m ³
Plastic bending moment	$M_{pl,z,Rd}$	14,14	kNm
Unity check		0,11	-

Shear check for V_y

According to EN 1993-1-1 article 6.2.6 and formula (6.17)

Shear correction factor	η	1,20	
Shear area	A_v	8,1800e-04	m ²
Plastic shear resistance for V_y	$V_{pl,y,Rd}$	129,67	kN
Unity check		0,01	-

Shear check for V_z

According to EN 1993-1-1 article 6.2.6 and formula (6.17)

Shear correction factor	η	1,20	
Shear area	A_w	8,1800e-04	m ²
Plastic shear resistance for V_z	$V_{pl,Rd}$	129,87	kN
Unity check		0,00	-

Torsion check

According to EN 1993-1-1 article 6.2.7 and formula (6.23)

Index of fibre	Fibre	1	
Total torsional moment	T_{Ed}	4,1	MPa
Elastic shear resistance	T_{Rd}	158,8	MPa
Unity check		0,03	-

Note: The unity check for torsion is lower than the limit value of 0,05. Therefore torsion is considered as insignificant and is ignored in the combined checks.

Combined bending, axial force and shear force check

According to EN 1993-1-1 article 6.2.9.1 and formula (6.41)

Design plastic moment resistance reduced due to N_{Ed}	$M_{N,y,Rd}$	11,26	kNm
Exponent of bending ratio y	α	1,99	
Design plastic moment resistance reduced due to N_{Ed}	$M_{N,z,Rd}$	11,26	kNm
Exponent of bending ratio z	β	1,99	

Unity check (6.41) = 0,00 + 0,02 = 0,02 -

Note: Since the shear forces are less than half the plastic shear resistances their effect on the moment resistances is neglected.

The member satisfies the section check.

...::STABILITY CHECK::...

Classification for member buckling design

Decisive position for stability classification: 0,000 m

Classification according to EN 1993-1-1 article 5.5.2

Classification of Internal and Outstand parts according to EN 1993-1-1 Table 5.2 Sheet 1 & 2

Id	Type	c [mm]	t [mm]	σ_1 [kN/m ²]	σ_2 [kN/m ²]	ψ [-]	k_σ [-]	α [-]	c/t [-]	Class 1 Limit [-]	Class 2 Limit [-]	Class 3 Limit [-]	Class
1	I	75	5	1,440e+05	8,436e+04	0,59		1,00	15,00	25,88	31,43	41,03	1
3	I	75	5	7,934e+04	6,373e+04	0,80		1,00	15,00	25,88	31,43	37,70	1
5	I	75	5	6,667e+04	1,264e+05	0,53		1,00	15,00	25,88	31,43	42,01	1
7	I	75	5	1,314e+05	1,470e+05	0,89		1,00	15,00	25,88	31,43	36,47	1

Note: The Classification limits have been set according to Semi-Comp+. The cross-section is classified as Class 1

Flexural Buckling check

According to EN 1993-1-1 article 6.3.1.1 and formula (6.46)

Buckling parameters		yy	zz	
Sway type		sway	non-sway	
System length	L	2,987	2,987	m
Buckling factor	k	1,00	0,88	
Buckling length	l_{cr}	2,987	2,626	m
Critical Euler load	N_{cr}	448,10	580,02	kN
Slenderness	λ	86,99	76,46	
Relative slenderness	λ_{rel}	1,00	0,88	
Limit slenderness	$\lambda_{rel,0}$	0,20	0,20	
Buckling curve	c	c	c	
Imperfection	α	0,49	0,49	
Reduction factor	χ	0,54	0,61	
Buckling resistance	$N_{b,Rd}$	242,39	275,21	kN

Flexural Buckling verification

Cross-section area	A	1,6360e-03	m ²
Buckling resistance	$N_{b,Rd}$	242,39	kN
Unity check		0,71	-

Torsional(-Flexural) Buckling check

According to EN 1993-1-1 article 6.3.1.1 and formula (6.46)

Note: The cross-section concerns a RHS section which is not susceptible to Torsional(-Flexural) Buckling.

Lateral Torsional Buckling check

According to EN 1993-1-1 article 6.3.2.1

Note: The cross-section concerns an RHS section with $h / b < 10 / \lambda_{rel,z}^2$. This section is thus not susceptible to Lateral Torsional Buckling.

Bending and axial compression check

According to EN 1993-1-1 article 6.3.3 and formula (6.61),(6.62)

Bending and axial compression check parameters			
Interaction method		alternative method 1	
Cross-section area	A	1,6360e-03	m ²
Plastic section modulus	$W_{pl,y}$	5,1410e-05	m ³
Plastic section modulus	$W_{pl,z}$	5,1410e-05	m ³
Design compression force	N_{Ed}	172,30	kN
Design bending moment (maximum)	$M_{y,Ed}$	-0,40	kNm
Design bending moment (maximum)	$M_{z,Ed}$	-1,54	kNm
Characteristic compression resistance	N_{Rk}	449,90	kN
Characteristic moment resistance	$M_{y,Rk}$	14,14	kNm
Characteristic moment resistance	$M_{z,Rk}$	14,14	kNm
Reduction factor	χ_y	0,54	
Reduction factor	χ_z	0,61	
Reduction factor	χ_{LT}	1,00	
Interaction factor	k_{yy}	0,95	
Interaction factor	k_{yz}	0,43	
Interaction factor	k_{zy}	0,73	
Interaction factor	k_{zz}	0,72	

Maximum moment $M_{y,Ed}$ is derived from beam B81 position 0,000 m.Maximum moment $M_{z,Ed}$ is derived from beam B81 position 0,000 m.

Interaction method 1 parameters			
Critical Euler load	$N_{cr,y}$	448,10	kN
Critical Euler load	$N_{cr,z}$	580,02	kN
Elastic critical load	$N_{cr,T}$	108546,10	kN
Plastic section modulus	$W_{pl,y}$	5,1410e-05	m ³
Elastic section modulus	$W_{el,y}$	4,2870e-05	m ³
Plastic section modulus	$W_{pl,z}$	5,1410e-05	m ³
Elastic section modulus	$W_{el,z}$	4,2870e-05	m ³
Second moment of area	I_y	1,9293e-06	m ⁴
Second moment of area	I_z	1,9293e-06	m ⁴
Torsional constant	I_t	3,1626e-06	m ⁴
Method for equivalent moment factor $C_{my,0}$		Table A.2 Line 2 (General)	
Design bending moment (maximum)	$M_{y,Ed}$	-0,40	kNm
Maximum relative deflection	δ_z	0,4	mm
Equivalent moment factor	$C_{my,0}$	0,77	
Method for equivalent moment factor $C_{mz,0}$		Table A.2 Line 1 (Linear)	
Ratio of end moments	ψ_z	-0,39	
Equivalent moment factor	$C_{mz,0}$	0,63	
Factor	μ_F	0,78	
Factor	μ_z	0,86	
Factor	ϵ_y	0,09	
Factor	α_{LT}	0,00	
Critical moment for uniform bending	$M_{cr,0}$	338,70	kNm
Relative slenderness	$\lambda_{rel,0}$	0,20	
Limit relative slenderness	$\lambda_{rel,0,lim}$	0,29	
Equivalent moment factor	C_{my}	0,77	
Equivalent moment factor	C_{mz}	0,63	
Equivalent moment factor	$C_{y,LT}$	1,00	
Factor	b_{LT}	0,00	
Factor	c_{LT}	0,00	
Factor	d_{LT}	0,00	
Factor	e_{LT}	0,00	
Factor	w_y	1,20	
Factor	w_z	1,20	
Factor	η_{pl}	0,38	
Maximum relative slenderness	$\lambda_{rel,max}$	1,00	
Factor	C_{yy}	1,03	
Factor	C_{yz}	0,98	
Factor	C_{zy}	0,89	
Factor	C_{zz}	1,07	

Unity check (6.61) = $0,71 + 0,03 + 0,05 = 0,78$ -Unity check (6.62) = $0,63 + 0,02 + 0,08 = 0,72$ -

The member satisfies the stability check.

4.2.7. Horizontala – gornja

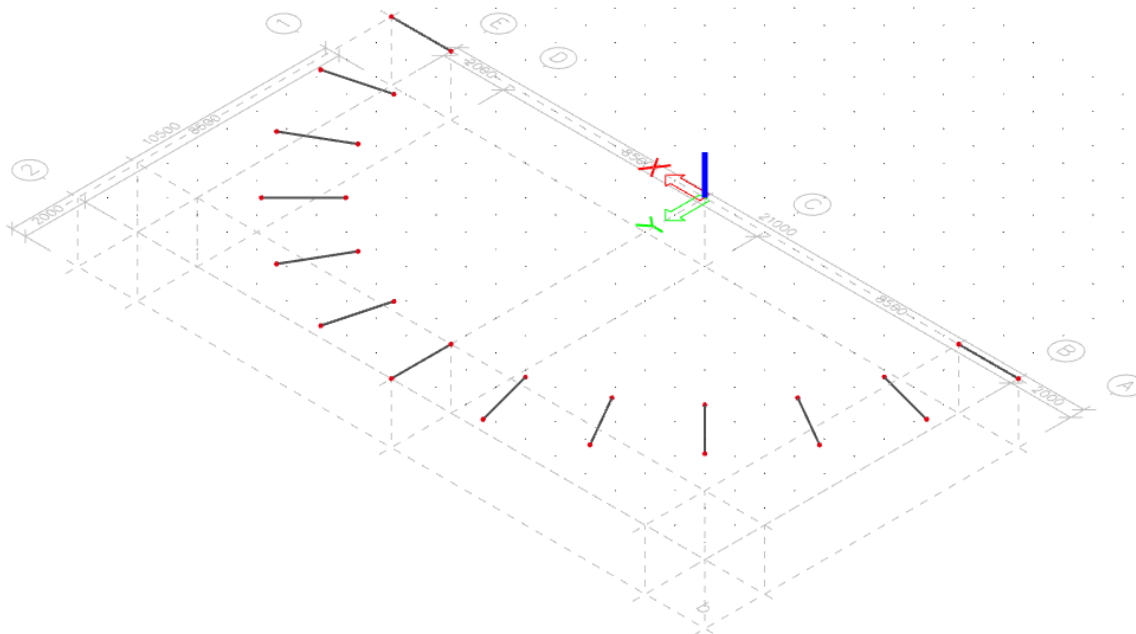

Slika 3.2.7.1. Prikaz položaja poprečnog presjeka

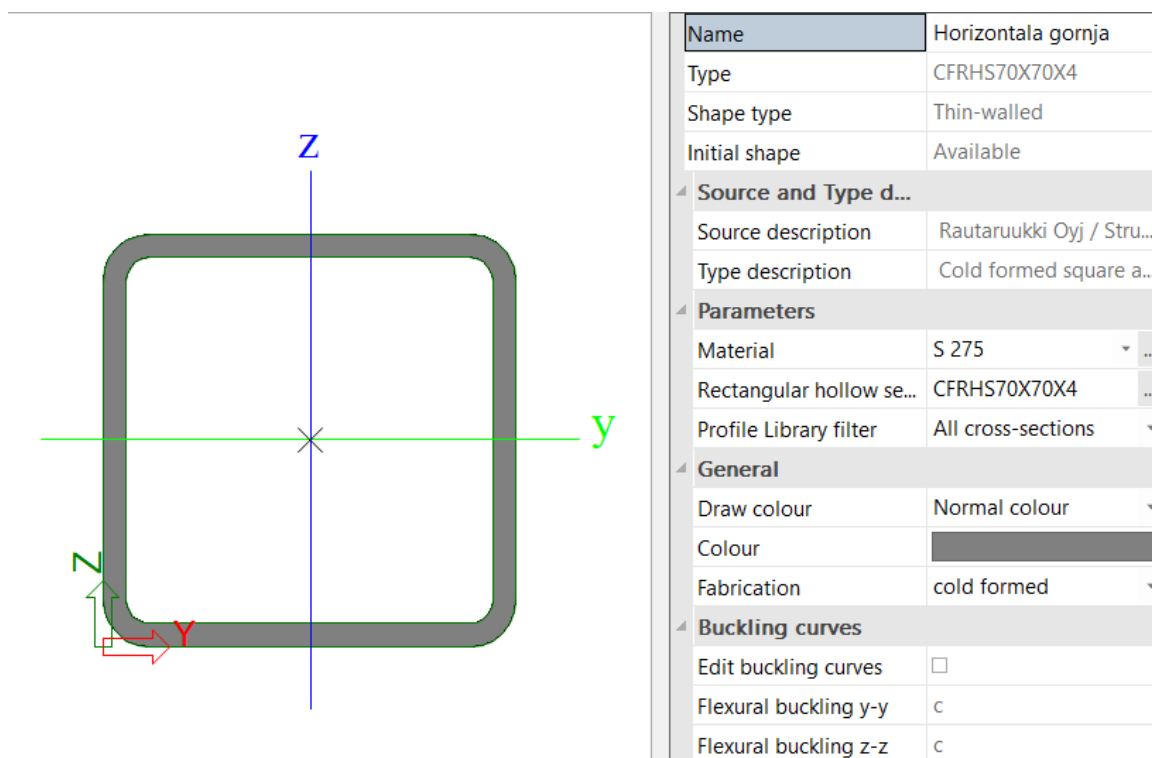

Slika 3.2.7.2. Poprečni presjek horizontala – gornjih

EC-EN 1993 Steel check ULS

Linear calculation
 Combination: 1.
 Coordinate system: Principal
 Extreme 1D: Global
 Selection: All

EN 1993-1-1 Code Check

National annex: Standard EN

Member	B112	0,000 / 2,000 m	CFRHS70X70X4	S 275	1.	0,64 -
--------	------	-----------------	--------------	-------	----	--------

Note: EN 1993-1-3 article 1.1(3) specifies that this part does not apply to cold formed CHS and RHS sections.
 The default EN 1993-1-1 code check is executed instead of the EN 1993-1-3 code check.

Combination key	
1.	/ 1.35*LC1 + 1.50*snijeg + 0.60*temperatura - + 0.30*vjetar

Partial safety factors	
γ_{M0} for resistance of cross-sections	1,00
γ_{M1} for resistance to instability	1,00
γ_{M2} for resistance of net sections	1,25

Material			
Yield strength	f_y	275,0	MPa
Ultimate strength	f_u	430,0	MPa
Fabrication		Cold formed	

....SECTION CHECK:....

The critical check is on position 0,000 m

Internal forces		Calculated	Unit
Normal force	N_{Ed}	-39,58	kN
Shear force	$V_{y,Ed}$	-0,13	kN
Shear force	$V_{z,Ed}$	-1,35	kN
Torsion	T_{Ed}	-0,02	kNm
Bending moment	$M_{y,Ed}$	1,58	kNm
Bending moment	$M_{z,Ed}$	0,17	kNm

Classification for cross-section design

Classification according to EN 1993-1-1 article 5.5.2

Classification of Internal and Outstand parts according to EN 1993-1-1 Table 5.2 Sheet 1 & 2

Id	Type	c [mm]	t [mm]	σ_1 [kN/m ²]	σ_2 [kN/m ²]	ψ [-]	k_{σ} [-]	α [-]	c/t [-]	Class 1 Limit [-]	Class 2 Limit [-]	Class 3 Limit [-]	Class
1	I	58	4	-4,008e+04	-2,665e+04								
3	I	58	4	-1,695e+04	1,103e+05	-0,15		0,87	14,50	30,92	37,30	58,58	1
5	I	58	4	1,181e+05	1,047e+05	0,89		1,00	14,50	25,88	31,43	36,57	1
7	I	58	4	9,498e+04	-3,223e+04	-0,34		0,75	14,50	37,50	44,85	65,63	1

Note: The Classification limits have been set according to Semi-Comp+.
 The cross-section is classified as Class 1

Compression check

According to EN 1993-1-1 article 6.2.4 and formula (6.9)

Cross-section area	A	1,0150e-03	m ²
Compression resistance	$N_{c,Rd}$	279,12	kN
Unity check		0,14	-

Bending moment check for M_y

According to EN 1993-1-1 article 6.2.5 and formula (6.12),(6.13)

Plastic section modulus	$W_{pl,y}$	2,4760e-05	m ³
Plastic bending moment	$M_{pl,y,Rd}$	6,81	kNm
Unity check		0,23	-

Bending moment check for M_z

According to EN 1993-1-1 article 6.2.5 and formula (6.12),(6.13)

Plastic section modulus	$W_{pl,z}$	2,4760e-05	m ³
Plastic bending moment	$M_{pl,z,Rd}$	6,81	kNm
Unity check		0,02	-

Shear check for V_y

According to EN 1993-1-1 article 6.2.6 and formula (6.17)

Shear correction factor	η	1,20	
Shear area	A_v	5,0750e-04	m ²
Plastic shear resistance for V_y	$V_{pl,y,Rd}$	80,56	kN
Unity check		0,00	-

Shear check for V_z

According to EN 1993-1-1 article 6.2.6 and formula (6.17)

Shear correction factor	η	1,20	
Shear area	A_v	5,0750e-04	m ²
Plastic shear resistance for V_z	$V_{pl,Rd}$	80,58	kN
Unity check		0,02	-

Torsion check

According to EN 1993-1-1 article 6.2.7 and formula (6.23)

Index of fibre	Fibre	1	
Total torsional moment	T_{Ed}	0,5	MPa
Elastic shear resistance	T_{Rd}	158,8	MPa
Unity check		0,00	-

Note: The unity check for torsion is lower than the limit value of 0,05. Therefore torsion is considered as insignificant and is ignored in the combined checks.

Combined bending, axial force and shear force check

According to EN 1993-1-1 article 6.2.9.1 and formula (6.41)

Design plastic moment resistance reduced due to N_{Ed}	$M_{N,V,Rd}$	6,81	kNm
Exponent of bending ratio y	α	1,70	
Design plastic moment resistance reduced due to N_{Ed}	$M_{N,z,Rd}$	6,81	kNm
Exponent of bending ratio z	β	1,70	

Unity check (6.41) = 0,08 + 0,00 = 0,09 -

Note: Since the shear forces are less than half the plastic shear resistances their effect on the moment resistances is neglected.

The member satisfies the section check.

...::STABILITY CHECK::...

Classification for member buckling design

Decisive position for stability classification: 0,000 m

Classification according to EN 1993-1-1 article 5.5.2

Classification of [Internal and Outstand parts according to EN 1993-1-1 Table 5.2 Sheet 1 & 2

Id	Type	c [mm]	t [mm]	σ_1 [kN/m ²]	σ_2 [kN/m ²]	ψ [-]	k_{σ} [-]	α [-]	c/t [-]	Class 1 Limit [-]	Class 2 Limit [-]	Class 3 Limit [-]	Class
1	I	58	4	-4,008e+04	-2,665e+04								
3	I	58	4	-1,695e+04	1,103e+05	-0,15		0,87	14,50	30,92	37,30	58,58	1
5	I	58	4	1,181e+05	1,047e+05	0,89		1,00	14,50	25,88	31,43	36,57	1
7	I	58	4	9,498e+04	-3,223e+04	-0,34		0,75	14,50	37,50	44,85	65,63	1

Note: The Classification limits have been set according to Semi-Comp+.

The cross-section is classified as Class 1

Flexural Buckling check

According to EN 1993-1-1 article 6.3.1.1 and formula (6.46)

Buckling parameters		yy	zz	
Sway type		sway	non-sway	
System length	L	2,000	2,000	m
Buckling factor	k	1,67	0,69	
Buckling length	l_{cr}	3,342	1,373	m
Critical Euler load	N_{cr}	133,82	793,13	kN
Slenderness	λ	125,38	51,50	
Relative slenderness	λ_{rel}	1,44	0,59	
Limit slenderness	$\lambda_{rel,0}$	0,20	0,20	
Buckling curve	c	c	c	
Imperfection	α	0,49	0,49	
Reduction factor	χ	0,33	0,79	
Buckling resistance	$N_{b,Rd}$	93,03	220,34	kN

Flexural Buckling verification

Cross-section area	A	1,0150e-03	m ²
Buckling resistance	$N_{b,Rd}$	93,03	kN
Unity check		0,43	-

Torsional(-Flexural) Buckling check

According to EN 1993-1-1 article 6.3.1.1 and formula (6.46)

Note: The cross-section concerns a RHS section which is not susceptible to Torsional(-Flexural) Buckling.

Lateral Torsional Buckling check

According to EN 1993-1-1 article 6.3.2.1

Note: The cross-section concerns an RHS section with $h/b < 10 / \lambda_{rel,z}^2$. This section is thus not susceptible to Lateral Torsional Buckling.

Bending and axial compression check

According to EN 1993-1-1 article 6.3.3 and formula (6.61),(6.62)

Bending and axial compression check parameters			
Interaction method		alternative method 1	
Cross-section area	A	1,0150e-03	m ²
Plastic section modulus	W _{pl,y}	2,4760e-05	m ³
Plastic section modulus	W _{pl,z}	2,4760e-05	m ³
Design compression force	N _{Ed}	39,58	kN
Design bending moment (maximum)	M _{y,Ed}	1,58	kNm
Design bending moment (maximum)	M _{z,Ed}	0,17	kNm
Characteristic compression resistance	N _{tk}	279,12	kN
Characteristic moment resistance	M _{y,Rk}	6,81	kNm
Characteristic moment resistance	M _{z,Rk}	6,81	kNm
Reduction factor	χ _y	0,33	
Reduction factor	χ _z	0,79	
Reduction factor	χ _{LT}	1,00	
Interaction factor	k _{yy}	0,88	
Interaction factor	k _{yz}	0,35	
Interaction factor	k _{zy}	0,76	
Interaction factor	k _{zz}	0,67	

Maximum moment M_{y,Ed} is derived from beam B112 position 0,000 m.
 Maximum moment M_{z,Ed} is derived from beam B112 position 0,000 m.

Interaction method 1 parameters			
Critical Euler load	N _{cr,y}	133,82	kN
Critical Euler load	N _{cr,z}	793,13	kN
Elastic critical load	N _{cr,T}	67566,73	kN
Plastic section modulus	W _{pl,y}	2,4760e-05	m ³
Elastic section modulus	W _{el,y}	2,0610e-05	m ³
Plastic section modulus	W _{pl,z}	2,4760e-05	m ³
Elastic section modulus	W _{el,z}	2,0610e-05	m ³
Second moment of area	I _y	7,2120e-07	m ⁴
Second moment of area	I _z	7,2120e-07	m ⁴
Torsional constant	I _t	1,1852e-06	m ⁴
Method for equivalent moment factor C _{my,0}		Table A.2 Line 2 (General)	
Design bending moment (maximum)	M _{y,Ed}	1,58	kNm
Maximum relative deflection	δ _z	-1,0	mm
Equivalent moment factor C _{my,0}		0,77	
Method for equivalent moment factor C _{mz,0}		Table A.2 Line 1 (Linear)	
Ratio of end moments	ψ _z	-0,61	
Equivalent moment factor C _{mz,0}		0,64	
Factor μ _y		0,78	
Factor μ _z		0,99	
Factor ε _y		1,97	
Factor α _{LT}		0,00	
Critical moment for uniform bending	M _{cr,0}	189,42	kNm
Relative slenderness λ _{rel,0}		0,19	
Limit relative slenderness λ _{rel,0,lim}		0,31	
Equivalent moment factor C _{my}		0,77	
Equivalent moment factor C _{mz}		0,64	
Equivalent moment factor C _{mLT}		1,00	
Factor b _{LT}		0,00	
Factor c _{LT}		0,00	
Factor d _{LT}		0,00	
Factor e _{LT}		0,00	
Factor w _y		1,20	
Factor w _z		1,20	
Factor η _{pl}		0,14	
Maximum relative slenderness λ _{rel,max}		1,44	
Factor C _{yy}		0,98	
Factor C _{yz}		0,92	
Factor C _{zy}		0,86	
Factor C _{zz}		1,00	

Unity check (6.61) = 0,43 + 0,20 + 0,01 = 0,64 -

Unity check (6.62) = 0,18 + 0,18 + 0,02 = 0,37 -

The member satisfies the stability check.

4.2.8. Horizontala – donja

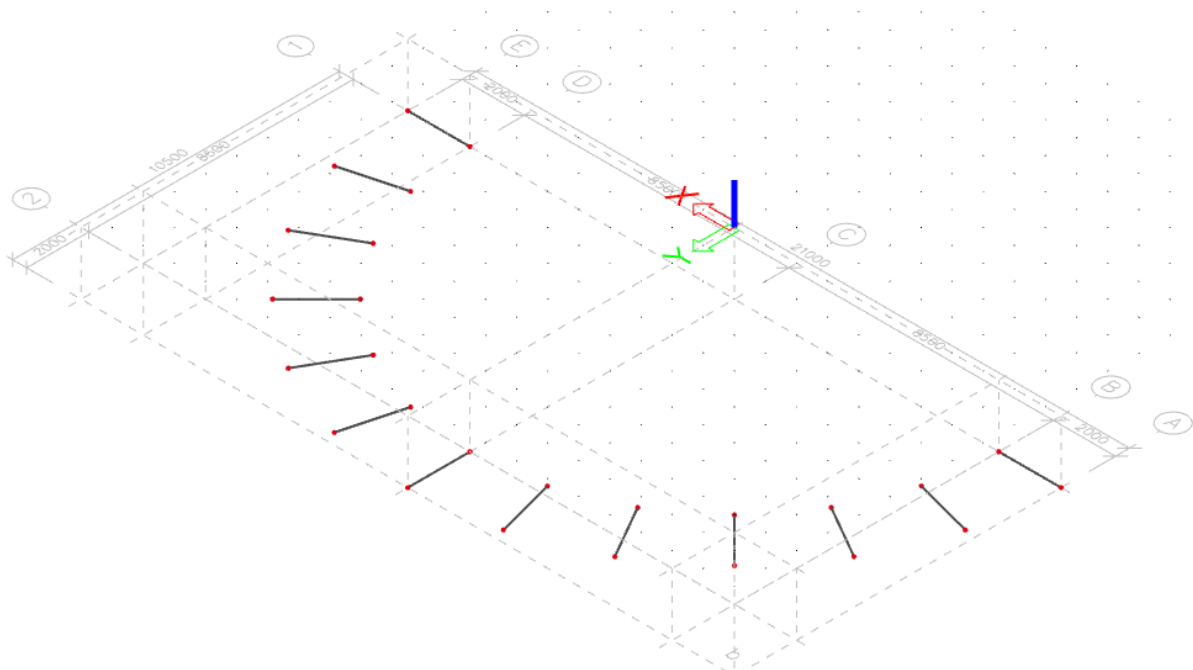

Slika 3.2.8.1. Prikaz položaja poprečnog presjeka

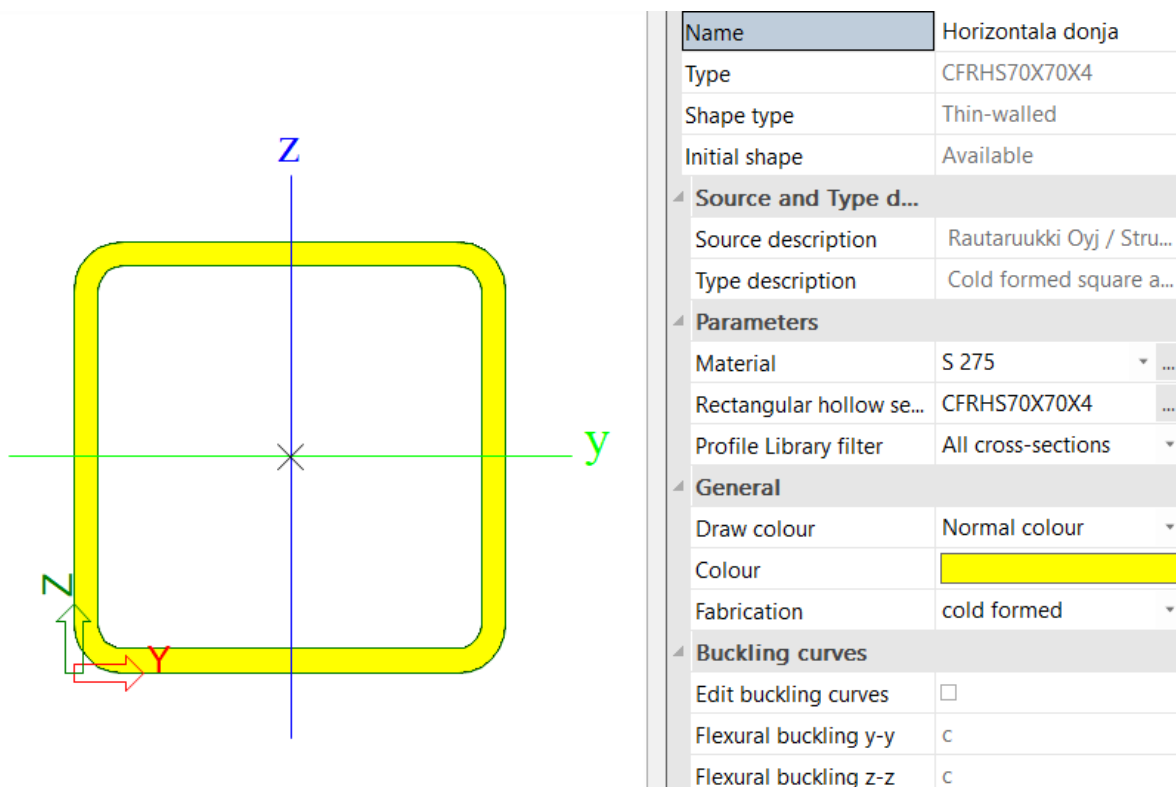

Slika 3.2.8.2. Poprečni presjek horizontala – donjih

EC-EN 1993 Steel check ULS

Linear calculation

Combination: 1.

Coordinate system: Principal

Extreme 1D: Global

Selection: All

EN 1993-1-1 Code Check

National annex: Standard EN

Member B47 0,000 / 2,000 m **CFRHS70X70X4** **S 275** **1.** **0,68 -**

Note: EN 1993-1-3 article 1.1(3) specifies that this part does not apply to cold formed CHS and RHS sections.

The default EN 1993-1-1 code check is executed instead of the EN 1993-1-3 code check.

Combination key1. / 1.35*LC1 + 1.50*snijeg + 0.60*temperatura - +
0.30*vjetar**Partial safety factors**

γ_{M0} for resistance of cross-sections	1,00
γ_{M1} for resistance to instability	1,00
γ_{M2} for resistance of net sections	1,25

Material

Yield strength	f_y	275,0	MPa
Ultimate strength	f_u	430,0	MPa
Fabrication		Cold formed	

...:SECTION CHECK:...

The critical check is on position 0,000 m

Internal forces		Calculated	Unit
Normal force	N_{Ed}	-69,58	kN
Shear force	$V_{y,Ed}$	-0,06	kN
Shear force	$V_{z,Ed}$	-1,46	kN
Torsion	T_{Ed}	0,01	kNm
Bending moment	$M_{y,Ed}$	1,53	kNm
Bending moment	$M_{z,Ed}$	0,06	kNm

Classification for cross-section design

Classification: according to EN 1993-1-1 article 5.5.2

Classification of Internal and Outstand parts according to EN 1993-1-1 Table 5.2 Sheet 1 & 2

Id	Type	c [mm]	t [mm]	σ_1 [kN/m ²]	σ_2 [kN/m ²]	ψ [-]	k_σ [-]	α [-]	c/t [-]	Class 1 Limit [-]	Class 2 Limit [-]	Class 3 Limit [-]	Class
1	I	58	4	-3,991e+03	9,730e+02	-4,10		0,20	14,50	169,79	195,73	592,26	1
3	I	58	4	9,811e+03	1,330e+05	0,07		1,00	14,50	25,88	31,43	51,77	1
5	I	58	4	1,411e+05	1,362e+05	0,96		1,00	14,50	25,88	31,43	35,56	1
7	I	58	4	1,273e+05	4,161e+03	0,03		1,00	14,50	25,88	31,43	52,88	1

Note: The Classification limits have been set according to Semi-Comp+.

The cross-section is classified as Class 1

Compression check

According to EN 1993-1-1 article 6.2.4 and formula (6.9)

Cross-section area	A	1,0150e-03	m ²
Compression resistance	$N_{c,Rd}$	279,12	kN
Unity check		0,25	-

Bending moment check for M_y

According to EN 1993-1-1 article 6.2.5 and formula (6.12),(6.13)

Plastic section modulus	$W_{pl,y}$	2,4760e-05	m ³
Plastic bending moment	$M_{pl,y,Rd}$	6,81	kNm
Unity check		0,22	-

Bending moment check for M_z

According to EN 1993-1-1 article 6.2.5 and formula (6.12),(6.13)

Plastic section modulus	$W_{pl,z}$	2,4760e-05	m ³
Plastic bending moment	$M_{pl,z,Rd}$	6,81	kNm
Unity check		0,01	-

Shear check for V_y

According to EN 1993-1-1 article 6.2.6 and formula (6.17)

Shear correction factor	η	1,20	
Shear area	A_v	5,0750e-04	m ²
Plastic shear resistance for V_y	$V_{pl,y,Rd}$	80,56	kN
Unity check		0,00	-

Shear check for V_z

According to EN 1993-1-1 article 6.2.6 and formula (6.17)

Shear correction factor	η	1,20	
Shear area	A_v	5,0750e-04	m ²
Plastic shear resistance for V_z	$V_{pl,z,Rd}$	80,58	kN
Unity check		0,02	-

Torsion check

According to EN 1993-1-1 article 6.2.7 and formula (6.23)

Index of fibre	Fibre	1	
Total torsional moment	T_{Ed}	0,1	MPa
Elastic shear resistance	τ_{Rd}	158,8	MPa
Unity check		0,00	-

Note: The unity check for torsion is lower than the limit value of 0,05. Therefore torsion is considered as insignificant and is ignored in the combined checks.

Combined bending, axial force and shear force check

According to EN 1993-1-1 article 6.2.9.1 and formula (6.41)

Design plastic moment resistance reduced due to N_{Ed}	$M_{N,y,Rd}$	6,59	kNm
Exponent of bending ratio γ	α	1,79	
Design plastic moment resistance reduced due to N_{Ed}	$M_{N,z,Rd}$	6,59	kNm
Exponent of bending ratio z	β	1,79	

Unity check (6.41) = 0,07 + 0,00 = 0,07 -

Note: Since the shear forces are less than half the plastic shear resistances their effect on the moment resistances is neglected.

The member satisfies the section check.

....**STABILITY CHECK**:....

Classification for member buckling design

Decisive position for stability classification: 2,000 m

Classification according to EN 1993-1-1 article 5.5.2

Classification of [Internal and Outstand parts according to EN 1993-1-1 Table 5.2 Sheet 1 & 2

Id	Type	c [mm]	t [mm]	σ_1 [kN/m ²]	σ_2 [kN/m ²]	ψ [-]	k_{σ} [-]	α [-]	c/t [-]	Class 1 Limit [-]	Class 2 Limit [-]	Class 3 Limit [-]	Class
1	I	58	4	1,448e+05	1,397e+05	0,97		1,00	14,50	25,88	31,43	35,56	1
3	I	58	4	1,304e+05	9,751e+02	0,01		1,00	14,50	25,88	31,43	53,58	1
5	I	58	4	-7,606e+03	-2,566e+03								
7	I	58	4	6,711e+03	1,362e+05	0,05		1,00	14,50	25,88	31,43	52,42	1

Note: The Classification limits have been set according to Semi-Comp+.

The cross-section is classified as Class 1

Flexural Buckling check

According to EN 1993-1-1 article 6.3.1.1 and formula (6.46)

Buckling parameters		yy	zz	
Sway type		sway	non-sway	
System length	L	2,000	2,000	m
Buckling factor	k	1,17	0,72	
Buckling length	l_{cr}	2,347	1,442	m
Critical Euler load	N_{cr}	271,39	718,79	kN
Slenderness	λ	88,04	54,10	
Relative slenderness	λ_{rel}	1,01	0,62	
Limit slenderness	$\lambda_{rel,0}$	0,20	0,20	
Buckling curve	c	c	c	
Imperfection	α	0,49	0,49	
Reduction factor	χ	0,53	0,77	
Buckling resistance	$N_{b,Rd}$	148,43	215,37	kN

Flexural Buckling verification		
Cross-section area	A	1,0150e-03 m ²
Buckling resistance	$N_{b,Rd}$	148,43 kN
Unity check		0,47 -

Torsional(-Flexural) Buckling check

According to EN 1993-1-1 article 6.3.1.1 and formula (6.46)

Note: The cross-section concerns a RHS section which is not susceptible to Torsional(-Flexural) Buckling.

Lateral Torsional Buckling check

According to EN 1993-1-1 article 6.3.2.1

Note: The cross-section concerns an RHS section with $h / b < 10 / \lambda_{rel,z}^2$. This section is thus not susceptible to Lateral Torsional Buckling.

Bending and axial compression check

According to EN 1993-1-1 article 6.3.3 and formula (6.61),(6.62)

Bending and axial compression check parameters			
Interaction method	alternative method 1		
Cross-section area	A	1,0150e-03	m ²
Plastic section modulus	W _{pl,y}	2,4760e-05	m ³
Plastic section modulus	W _{pl,z}	2,4760e-05	m ³
Design compression force	N _{Ed}	69,58	kN
Design bending moment (maximum)	M _{y,Ed}	-1,61	kNm
Design bending moment (maximum)	M _{z,Ed}	-0,06	kNm
Characteristic compression resistance	N _{tk}	279,12	kN
Characteristic moment resistance	M _{y,Rk}	6,81	kNm
Characteristic moment resistance	M _{z,Rk}	6,81	kNm
Reduction factor	χ _y	0,53	
Reduction factor	χ _z	0,77	
Reduction factor	χ _{LT}	1,00	
Interaction factor	k _{yy}	0,89	
Interaction factor	k _{yz}	0,30	
Interaction factor	k _{zy}	0,67	
Interaction factor	k _{zz}	0,55	

Maximum moment M_{y,Ed} is derived from beam B47 position 2,000 m.Maximum moment M_{z,Ed} is derived from beam B47 position 2,000 m.

Interaction method 1 parameters			
Critical Euler load	N _{cr,y}	271,39	kN
Critical Euler load	N _{cr,z}	718,79	kN
Elastic critical load	N _{cr,T}	67566,73	kN
Plastic section modulus	W _{pl,y}	2,4760e-05	m ³
Elastic section modulus	W _{el,y}	2,0610e-05	m ³
Plastic section modulus	W _{pl,z}	2,4760e-05	m ³
Elastic section modulus	W _{el,z}	2,0610e-05	m ³
Second moment of area	I _y	7,2120e-07	m ⁴
Second moment of area	I _z	7,2120e-07	m ⁴
Torsional constant	I _t	1,1852e-06	m ⁴
Method for equivalent moment factor C _{my,0}	Table A.2 Line 2 (General)		
Design bending moment (maximum)	M _{y,Ed}	-1,61	kNm
Maximum relative deflection	δ _L	-0,7	mm
Equivalent moment factor C _{my,0}		0,78	
Method for equivalent moment factor C _{my,0}	Table A.2 Line 1 (Linear)		
Ratio of end moments	ψ _z	-0,98	
Equivalent moment factor C _{my,0}		0,54	
Factor	μ _y	0,86	
Factor	μ _z	0,98	
Factor	ε _y	1,14	
Factor	α _{LT}	0,00	
Critical moment for uniform bending	M _{cr,0}	189,42	kNm
Relative slenderness	λ _{rel,0}	0,19	
Limit relative slenderness	λ _{rel,0,lim}	0,31	
Equivalent moment factor C _{my}		0,78	
Equivalent moment factor C _{my}		0,54	
Equivalent moment factor C _{my,LT}		1,00	
Factor	b _{LT}	0,00	
Factor	c _{LT}	0,00	
Factor	d _{LT}	0,00	
Factor	e _{LT}	0,00	
Factor	w _y	1,20	
Factor	w _z	1,20	
Factor	η _{pl}	0,25	
Maximum relative slenderness	λ _{rel,max}	1,01	
Factor	C _{yy}	1,02	
Factor	C _{yz}	1,02	
Factor	C _{zy}	0,92	
Factor	C _{zz}	1,06	

Unity check (6.61) = 0,47 + 0,21 + 0,00 = 0,68 -

Unity check (6.62) = 0,32 + 0,16 + 0,01 = 0,49 -

The member satisfies the stability check.

4.3. Odabir glavne nosive konstrukcije

Analizirajući rješavanje izvedbe „Nebeska šetnica – Skywalk Biokovo“ kao čelične konstrukcije, zaključak je da su oba rješenja, tropojasna rešetka i četveropojasna rešetka, moguća i funkcionalna za ovaj konkretni slučaj. Međutim, rješenje s četveropojasnom rešetkom kao glavnom nosivom konstrukcijom zahtjeva veću količinu utrošenog materijala, nego je to u opciji s tropojasnom rešetkom kao glavnom nosivom konstrukcijom. (Slika 3.3.1., Slika 3.3.2) Iz navedenog razloga, opcija s tropojasnom rešetkom je optimalnija te će se u nastavku samo ona razmatrati.

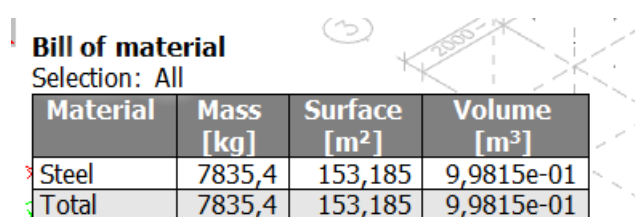

Bill of material
Selection: All

Material	Mass [kg]	Surface [m ²]	Volume [m ³]
Steel	7835,4	153,185	9,9815e-01
Total	7835,4	153,185	9,9815e-01

Slika 3.3.1. Ukupna količina utrošenog materijala kod tropojasne čelične konstrukcije

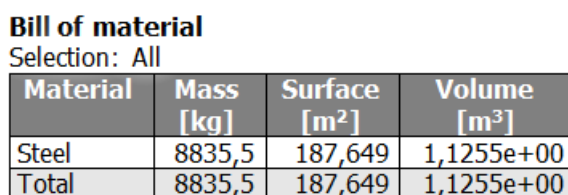

Bill of material
Selection: All

Material	Mass [kg]	Surface [m ²]	Volume [m ³]
Steel	8835,5	187,649	1,1255e+00
Total	8835,5	187,649	1,1255e+00

Slika 3.3.2. Ukupna količina utrošenog materijala kod četveropojasne čelične konstrukcije

5. SPOJEVI GLAVNE ČELIČNE KONSTRUKCIJE

Spojevi glavne čelične konstrukcije izračunate su pomoću software-a IDEA StatiCa dok su montažni nastavci segmenata izračunati preko Eurokoda.

5.1. Spoj donji pojas - vertikalna

Project:
Project no:
Author:

IDEA StatiCa[®]
Calculator for steel structures

Project data

Project name
Project number
Author
Description
Date 9/6/2021
Design code EN

Material

Steel S 275

Project:
Project no:
Author:



Project item Con N51

Design

Name: Con N51
Description:
Analysis: Stress, strain/ loads in equilibrium

Beams and columns

Name	Cross-section	β - Direction [°]	γ - Pitch [°]	α - Rotation [°]	Offset ex [mm]	Offset ey [mm]	Offset ez [mm]	Forces in
B117	1 - CFRHS90X90X5(RHS90x90)	0.0	0.0	0.0	0	0	0	Position
B118	1 - CFRHS90X90X5(RHS90x90)	0.0	0.0	0.0	0	0	0	Position
B119	1 - CFRHS90X90X5(RHS90x90)	0.0	0.0	0.0	0	0	0	Position
B120	1 - CFRHS90X90X5(RHS90x90)	0.0	0.0	0.0	0	0	0	Position
B132	2 - CFRHS180X100X5(RHS180x100)	0.0	0.0	0.0	0	0	0	Position
B133	2 - CFRHS180X100X5(RHS180x100)	0.0	0.0	0.0	0	0	0	Position

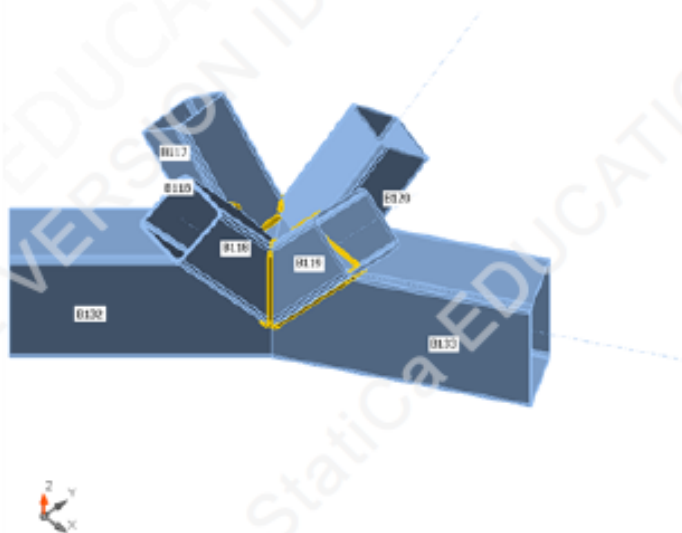

Cross-sections

Name	Material
1 - CFRHS90X90X5(RHS90x90)	S 275
2 - CFRHS180X100X5(RHS180x100)	S 275

Project:
Project no:
Author:



Load effects (forces in equilibrium)

Name	Member	N [kN]	Vy [kN]	Vz [kN]	Mx [kNm]	My [kNm]	Mz [kNm]
1.(1)	B117	-170.5	-0.1	-0.6	0.0	-0.3	0.5
	B118	14.9	-0.2	-0.1	-0.1	-0.3	0.5
	B119	24.4	0.0	-0.5	0.2	0.1	0.3
	B120	-178.3	0.1	-0.1	0.1	0.2	0.6
	B132	112.8	0.3	-0.2	0.8	-0.1	-0.5
	B133	53.9	-1.1	-0.8	-1.0	0.3	-1.0

Check

Summary

Name	Value	Status
Analysis	100.0%	OK
Plates	0.9 < 5.0%	OK
Welds	99.1 < 100%	OK
Buckling	Not calculated	
GMNA	Calculated	

Plates

Name	Thickness [mm]	Loads	σ_{Ed} [MPa]	ϵ_{pl} [%]	σ_{cEd} [MPa]	Status
B117	5.0	1.(1)	275.2	0.1	0.0	OK
B118	5.0	1.(1)	275.1	0.0	0.0	OK
B119	5.0	1.(1)	276.9	0.9	0.0	OK
B120	5.0	1.(1)	275.8	0.4	0.0	OK
B132	5.0	1.(1)	275.1	0.0	0.0	OK
B133	5.0	1.(1)	243.2	0.0	0.0	OK

Design data

Material	f_y [MPa]	ϵ_{lim} [%]
S 275	275.0	5.0

Symbol explanation

ϵ_{pl}	Strain
σ_{Ed}	Eq. stress
σ_{cEd}	Contact stress
f_y	Yield strength
ϵ_{lim}	Limit of plastic strain

Project:
Project no:
Author:



Overall check, 1.(1)

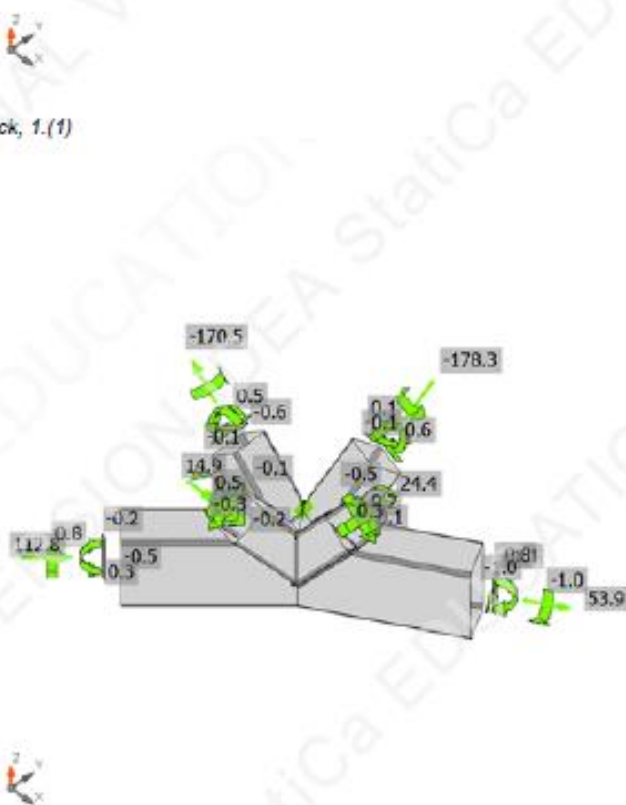

Strain check, 1.(1)

Project:
Project no:
Author:

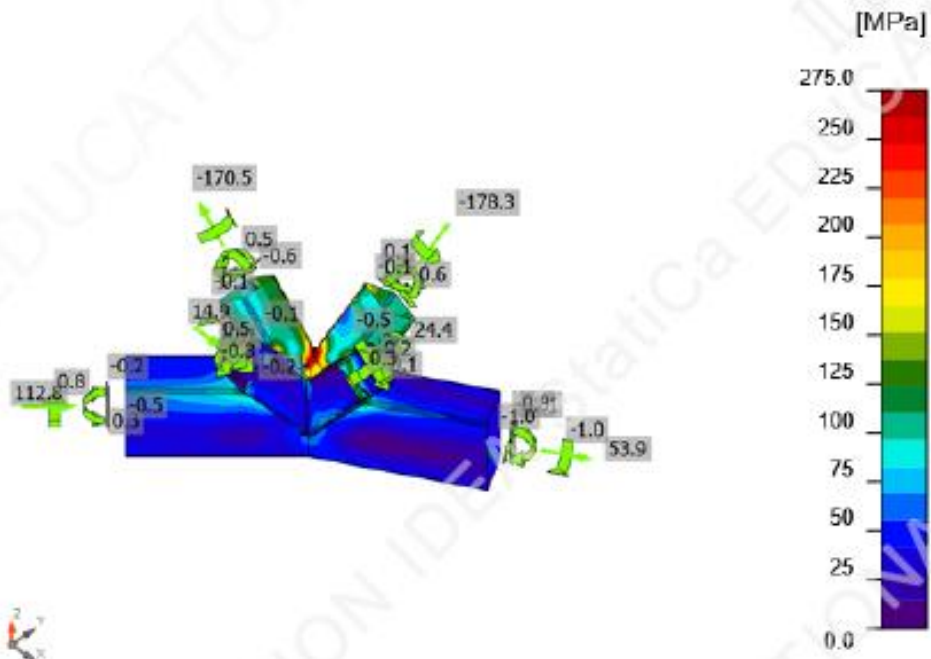

Equivalent stress, 1.(1)

Project:
Project no:
Author:



Welds (Plastic redistribution)

Item	Edge	Throat th. [mm]	Length [mm]	Loads	$\sigma_{w,Ed}$ [MPa]	ϵ_{pl} [%]	σ_{\perp} [MPa]	τ_{\parallel} [MPa]	τ_{\perp} [MPa]	Ut [%]	Ut _c [%]	Status
B133-w 3	B119	▲3.0▲	274	1.(1)	397.2	0.4	-47.4	-219.8	-59.4	98.1	17.3	OK
B132-w 3	B119	▲3.0▲	122	1.(1)	401.1	2.8	34.5	11.6	-230.4	99.1	23.0	OK
B117-arc 9	B118	▲3.0▲	28	1.(1)	376.5	0.0	-161.7	-101.9	-167.7	93.0	65.9	OK
B119-w 4	B118	▲3.0▲	176	1.(1)	273.5	0.0	-30.0	-33.7	-153.3	67.6	11.8	OK
B133-arc 6	B120	▲3.0▲	170	1.(1)	397.2	0.4	-203.4	131.3	-146.9	98.2	30.8	OK
B132-arc 5	B120	▲3.0▲	114	1.(1)	398.0	0.8	169.2	10.8	-207.7	98.3	68.7	OK
B119-w 2	B120	▲3.0▲	92	1.(1)	333.4	0.0	-129.6	-131.2	-119.4	82.4	29.6	OK
B132-w 3	B117	▲3.0▲	313	1.(1)	398.3	1.1	35.4	205.1	102.1	98.4	28.0	OK
B120-w 3	B117	▲3.0▲	135	1.(1)	398.3	1.0	13.9	-120.5	-195.7	98.4	48.5	OK
		▲3.0▲	274	1.(1)	396.9	0.2	-94.7	178.4	133.0	98.1	11.1	OK
		▲3.0▲	122	1.(1)	398.3	1.1	-268.0	159.7	58.7	98.4	14.0	OK
		▲3.0▲	28	1.(1)	397.2	0.4	283.4	-132.8	-90.5	98.1	44.0	OK
		▲3.0▲	176	1.(1)	132.7	0.0	-55.1	40.5	56.8	32.8	10.1	OK
		▲3.0▲	170	1.(1)	398.6	1.2	-152.4	-118.4	176.6	98.5	17.4	OK
		▲3.0▲	114	1.(1)	397.1	0.3	-197.9	-164.5	-111.5	98.1	26.0	OK
		▲3.0▲	92	1.(1)	396.7	0.0	-94.7	-126.5	182.9	98.0	33.7	OK
		▲3.0▲	313	1.(1)	397.3	0.4	196.6	-24.3	-197.8	98.2	18.7	OK
		▲3.0▲	135	1.(1)	398.8	1.3	-4.5	188.1	-132.7	98.5	40.7	OK
B133-w 1	B132-w 1	3.0	81	1.(1)								OK
B133-arc 1	B132-arc 1	3.0	4	1.(1)								OK
B133-arc 2	B132-arc 2	3.0	4	1.(1)								OK
B133-arc 3	B132-arc 3	3.0	4	1.(1)								OK
B133-arc 10	B132-arc 10	3.0	4	1.(1)								OK
B133-arc 11	B132-arc 11	3.0	4	1.(1)								OK
B133-arc 12	B132-arc 12	3.0	4	1.(1)								OK
B133-w 2	B132-w 2	3.0	160	1.(1)								OK
B133-arc 4	B132-arc 4	3.0	4	1.(1)								OK
B133-arc 5	B132-arc 5	3.0	4	1.(1)								OK
B133-arc 6	B132-arc 6	3.0	4	1.(1)								OK
B133-w 3	B132-w 3	3.0	81	1.(1)								OK
B133-arc 7	B132-arc 7	3.0	4	1.(1)								OK
B133-arc 8	B132-arc 8	3.0	4	1.(1)								OK
B133-arc 9	B132-arc 9	3.0	4	1.(1)								OK
B133-w 4	B132-w 4	3.0	160	1.(1)								OK

Design data

	β_w [-]	$\sigma_{w,Rd}$ [MPa]	0.9 σ [MPa]
S 275	0.85	404.7	309.6

Project:
Project no:
Author:



Symbol explanation

ϵ_{pl}	Strain
$\sigma_{w,Ed}$	Equivalent stress
$\sigma_{w,Rd}$	Equivalent stress resistance
σ_{\perp}	Perpendicular stress
τ_{\parallel}	Shear stress parallel to weld axis
τ_{\perp}	Shear stress perpendicular to weld axis
0.9σ	Perpendicular stress resistance - $0.9 \cdot f_u / \gamma_{M2}$
β_w	Correlation factor EN 1993-1-8 tab. 4.1
Ut	Utilization
Utc	Weld capacity utilization

Buckling

Buckling analysis was not calculated.

Code settings

Item	Value	Unit	Reference
YM0	1.00	-	EN 1993-1-1: 6.1
YM1	1.00	-	EN 1993-1-1: 6.1
YM2	1.25	-	EN 1993-1-1: 6.1
YM3	1.25	-	EN 1993-1-8: 2.2
Yc	1.50	-	EN 1992-1-1: 2.4.2.4
Yinst	1.20	-	EN 1992-4: Table 4.1
Joint coefficient β_j	0.67	-	EN 1993-1-8: 6.2.5
Effective area - influence of mesh size	0.10	-	
Friction coefficient - concrete	0.25	-	EN 1993-1-8
Friction coefficient in slip-resistance	0.30	-	EN 1993-1-8 tab 3.7
Limit plastic strain	0.05	-	EN 1993-1-5
Weld stress evaluation	Plastic redistribution		
Detailing	No		
Distance between bolts [d]	2.20	-	EN 1993-1-8: tab 3.3
Distance between bolts and edge [d]	1.20	-	EN 1993-1-8: tab 3.3
Concrete breakout resistance check	Both		EN 1992-4: 7.2.1.4 and 7.2.2.5
Use calculated o_b in bearing check.	Yes		EN 1993-1-8: tab 3.4
Cracked concrete	Yes		EN 1992-4
Local deformation check	No		CIDECT DG 1, 3 - 1.1
Local deformation limit	0.03	-	CIDECT DG 1, 3 - 1.1
Geometrical nonlinearity (GMNA)	Yes		Analysis with large deformations for hollow section joints
Braced system	No		EN 1993-1-8: 5.2.2.5

5.2. Spoj Gornji pojas – horizontale – dijagonale - vertikale

Project:
Project no:
Author:



Project item Con N22

Design

Name: Con N22
Description:
Analysis: Stress, strain/ loads in equilibrium

Beams and columns

Name	Cross-section	β - Direction [°]	γ - Pitch [°]	α - Rotation [°]	Offset ex [mm]	Offset ey [mm]	Offset ez [mm]	Forces in
B25	1 - CFRHS180X100X5(RHS180x100)	0.0	0.0	0.0	0	0	0	Position
B26	2 - CFRHS70X70X4(RHS70x70)	0.0	0.0	0.0	0	0	0	Position
B28	1 - CFRHS180X100X5(RHS180x100)	0.0	0.0	0.0	0	0	0	Position
B119	3 - CFRHS90X90X5(RHS90x90)	0.0	0.0	0.0	0	0	0	Position
B122	3 - CFRHS90X90X5(RHS90x90)	0.0	0.0	0.0	0	0	0	Position
B138	4 - CFRHS90X90X5(RHS90x90)	0.0	0.0	0.0	0	0	0	Position
B139	4 - CFRHS90X90X5(RHS90x90)	0.0	0.0	0.0	0	0	0	Position



Project:
Project no:
Author:



Cross-sections

Name	Material
1 - CFRHS180X100X5(RHS180x100)	S 275
2 - CFRHS70X70X4(RHS70x70)	S 275
3 - CFRHS90X90X5(RHS90x90)	S 275
4 - CFRHS90X90X5(RHS90x90)	S 275

Load effects (forces in equilibrium)

Name	Member	N [kN]	Vy [kN]	Vz [kN]	Mx [kNm]	My [kNm]	Mz [kNm]
1.(1)	B25	-60.3	-1.0	0.3	1.5	0.8	0.8
	B26	16.9	-0.5	0.0	0.1	-0.1	-0.5
	B28	-154.4	0.8	-0.3	-1.2	0.2	0.6
	B119	-24.7	0.0	0.3	-0.2	0.8	-0.3
	B122	-51.6	0.1	-0.4	0.2	0.7	-0.2
	B138	167.8	0.1	-0.2	0.2	0.6	-0.2
	B139	129.6	0.0	-0.3	-0.2	0.7	-0.2

Check

Summary

Name	Value	Status
Analysis	100.0%	OK
Plates	1.4 < 5.0%	OK
Welds	99.2 < 100%	OK
Buckling	Not calculated	
GMNA	Calculated	

Plates

Name	Thickness [mm]	Loads	σ_{Ed} [MPa]	ϵ_{pl} [%]	$\sigma_{C,Ed}$ [MPa]	Status
B25	5.0	1.(1)	276.4	0.7	0.0	OK
B26	4.0	1.(1)	275.3	0.2	0.0	OK
B28	5.0	1.(1)	275.7	0.4	0.0	OK
B119	5.0	1.(1)	278.0	1.4	0.0	OK
B122	5.0	1.(1)	276.2	0.6	0.0	OK
B138	5.0	1.(1)	275.9	0.4	0.0	OK
B139	5.0	1.(1)	275.5	0.2	0.0	OK

Design data

Material	f_y [MPa]	ϵ_{lim} [%]
S 275	275.0	5.0

Project:
Project no:
Author:



Symbol explanation

ϵ_{pl}	Strain
σ_{Ed}	Eq. stress
σ_{cEd}	Contact stress
f_y	Yield strength
ϵ_{lim}	Limit of plastic strain



Overall check, 1.(1)

Project:
Project no:
Author:

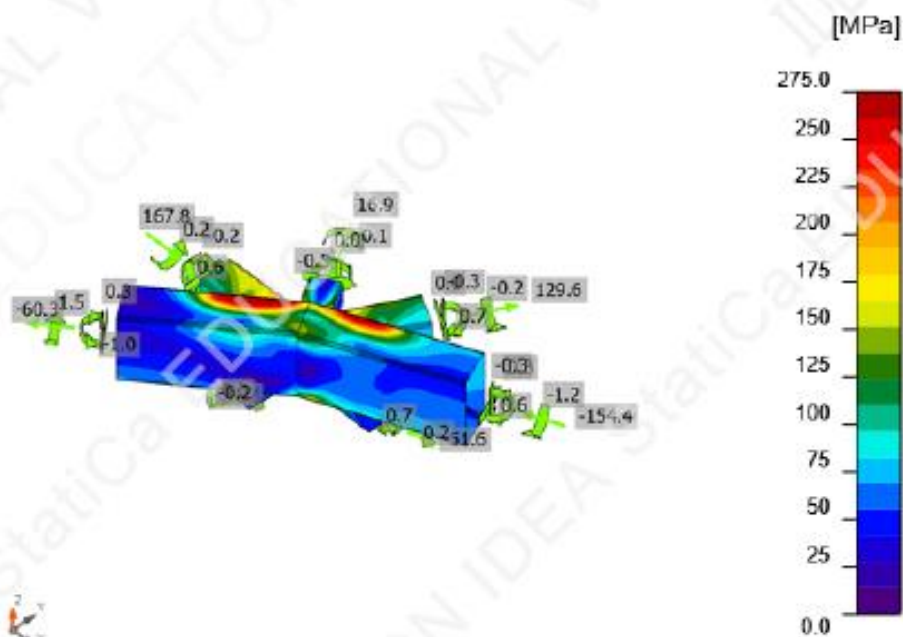
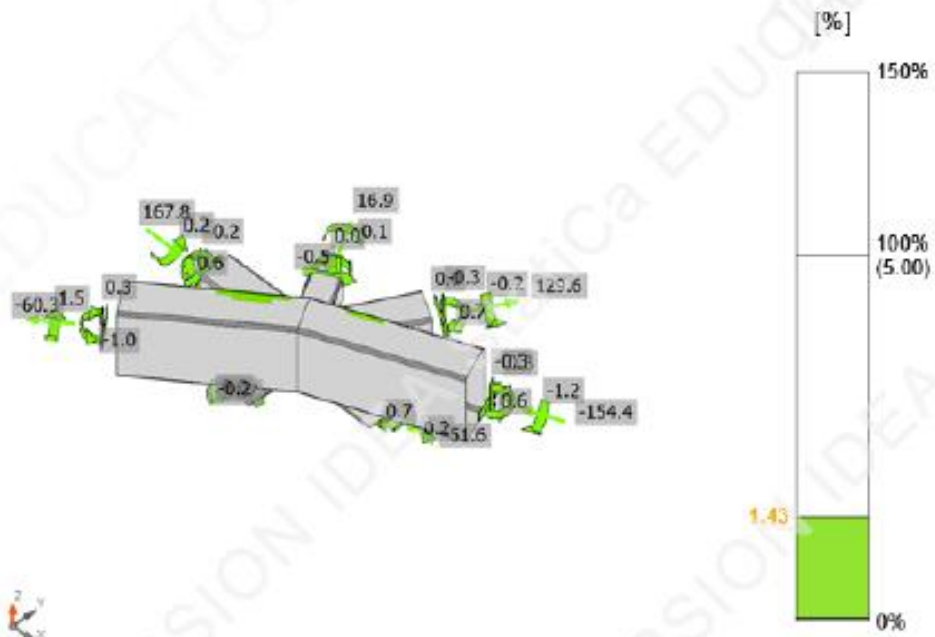

Project:
Project no:
Author:

IDEA StatiCa®
Calculate reality's stresses

Item	Edge	Throat th. [mm]	Length [mm]	Loads	$\sigma_{w,Ed}$ [MPa]	ϵ_{pl} [%]	σ_{\perp} [MPa]	τ_{\parallel} [MPa]	τ_{\perp} [MPa]	Ut [%]	Ut _c [%]	Status
B122-arc 4	B26-arc 10	4.0	2	1.(1)								OK
B122-arc 4	B26-arc 11	4.0	2	1.(1)								OK
B122-w 2	B26-arc 12	4.0	4	1.(1)								OK

Design data

	β_w [-]	$\sigma_{w,Rd}$ [MPa]	0.9 σ [MPa]
S 275	0.85	404.7	309.6

Symbol explanation

ϵ_{pl}	Strain
$\sigma_{w,Ed}$	Equivalent stress
$\sigma_{w,Rd}$	Equivalent stress resistance
σ_{\perp}	Perpendicular stress
τ_{\parallel}	Shear stress parallel to weld axis
τ_{\perp}	Shear stress perpendicular to weld axis
0.9 σ	Perpendicular stress resistance - 0.9 \cdot fu/γM2
β_w	Correlation factor EN 1993-1-8 tab. 4.1
Ut	Utilization
Ut _c	Weld capacity utilization

Buckling

Buckling analysis was not calculated.

Code settings

Item	Value	Unit	Reference
YM0	1.00	-	EN 1993-1-1: 6.1
YM1	1.00	-	EN 1993-1-1: 6.1
YM2	1.25	-	EN 1993-1-1: 6.1
YM3	1.25	-	EN 1993-1-8: 2.2
Yc	1.50	-	EN 1992-1-1: 2.4.2.4
Y _{inst}	1.20	-	EN 1992-4: Table 4.1
Joint coefficient β _j	0.67	-	EN 1993-1-8: 6.2.5
Effective area - influence of mesh size	0.10	-	
Friction coefficient - concrete	0.25	-	EN 1993-1-8
Friction coefficient in slip-resistance	0.30	-	EN 1993-1-8 tab 3.7
Limit plastic strain	0.05	-	EN 1993-1-5
Weld stress evaluation	Plastic redistribution		
Detailing	No		
Distance between bolts [d]	2.20	-	EN 1993-1-8: tab 3.3
Distance between bolts and edge [d]	1.20	-	EN 1993-1-8: tab 3.3
Concrete breakout resistance check	Both		EN 1992-4: 7.2.1.4 and 7.2.2.5
Use calculated ab in bearing check.	Yes		EN 1993-1-8: tab 3.4

Project:

Project no:

Author:



Item	Value	Unit	Reference
Cracked concrete	Yes		EN 1992-4
Local deformation check	No		CIDECT DG 1, 3 - 1.1
Local deformation limit	0.03	-	CIDECT DG 1, 3 - 1.1
Geometrical nonlinearity (GMNA)	Yes		Analysis with large deformations for hollow section joints
Braced system	No		EN 1993-1-8: 5.2.2.5

5.3. Spoj Temelj – donji pojas

Project:
Project no:
Author:



Project data

Project name
Project number
Author
Description
Date 9/14/2021
Design code EN

Material

Steel S 275
Concrete C25/30

Project:
Project no:
Author:



Project item CON1

Design

Name: CON1
Description:
Analysis: Stress, strain/ simplified loading

Beams and columns

Name	Cross-section	β - Direction [°]	γ - Pitch [°]	α - Rotation [°]	Offset ex [mm]	Offset ey [mm]	Offset ez [mm]	Forces in
COL	1 - donji pojas(RRO180X120X8K)	0.0	-90.0	0.0	0	0	0	Node

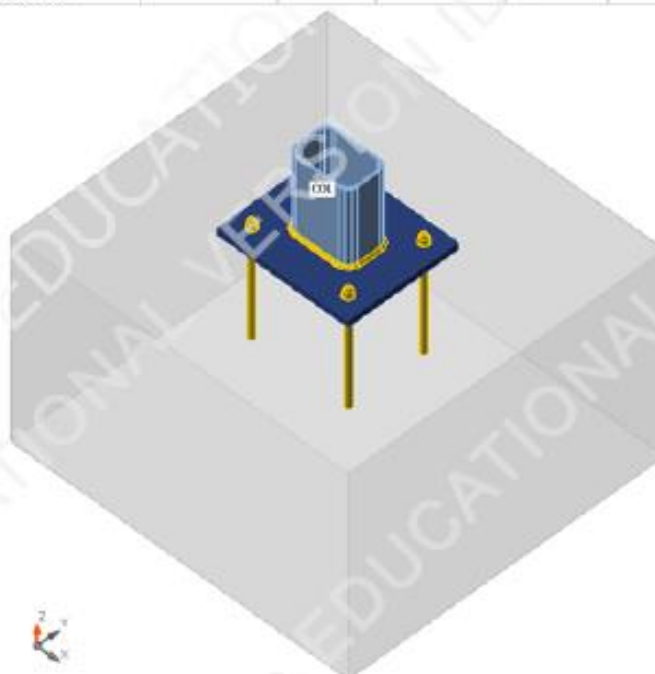

Cross-sections

Name	Material
1 - donji pojas(RRO180X120X8K)	S 275

Anchors

Name	Bolt assembly	Diameter [mm]	f_u [MPa]	Gross area [mm ²]
M16 8.8	M16 8.8	16	800.0	201

Project:
Project no:
Author:



Load effects (equilibrium not required)

Name	Member	N [kN]	Vy [kN]	Vz [kN]	Mx [kNm]	My [kNm]	Mz [kNm]
LE1	COL	-883.0	130.1	-17.7	0.0	0.0	0.0

Foundation block

Item	Value	Unit
CB 1		
Dimensions	920 x 1000	mm
Depth	600	mm
Anchor	M16 8.8	
Anchoring length	300	mm
Shear force transfer	Friction	

Check

Summary

Name	Value	Status
Analysis	100.0%	OK
Plates	0.2 < 5.0%	OK
Anchors	9.0 < 100%	OK
Welds	98.1 < 100%	OK
Concrete block	62.6 < 100%	OK
Shear	59.0 < 100%	OK
Buckling	Not calculated	

Plates

Name	Thickness [mm]	Loads	σ_{Ed} [MPa]	ϵ_{pl} [%]	σ_{cEd} [MPa]	Status
COL	10.0	LE1	275.5	0.2	0.0	OK
BP1	20.0	LE1	149.9	0.0	0.0	OK

Design data

Material	f_y [MPa]	ϵ_{lim} [%]
S 275	275.0	5.0

Symbol explanation

ϵ_{pl}	Strain
σ_{Ed}	Eq. stress
σ_{cEd}	Contact stress
f_y	Yield strength
ϵ_{lim}	Limit of plastic strain

Project:
Project no:
Author:

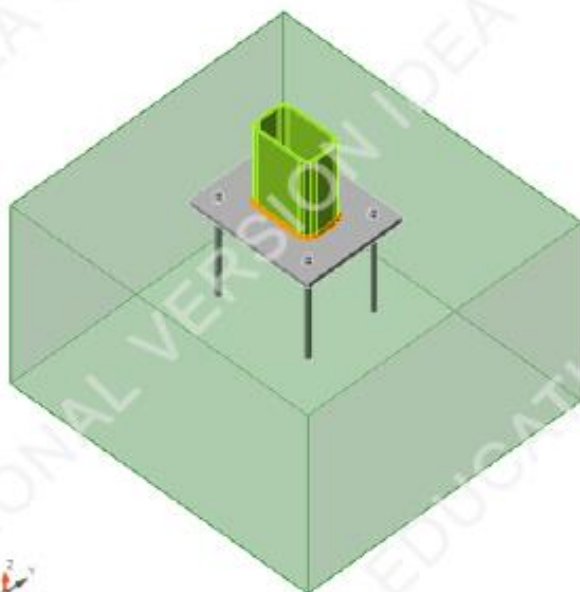

Overall check, LE1

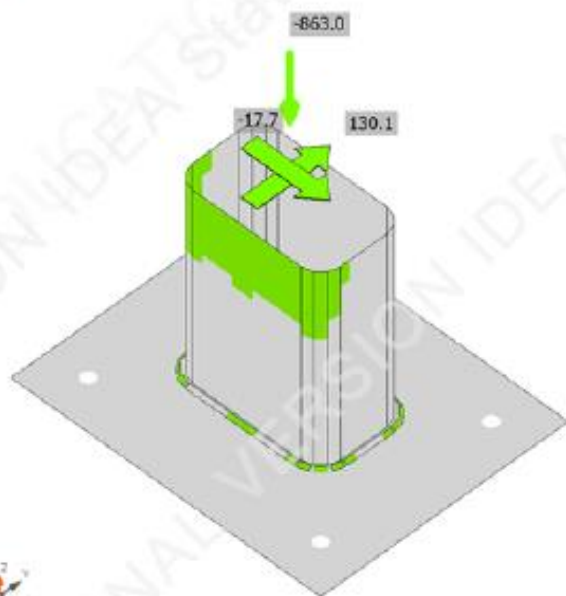

Strain check, LE1

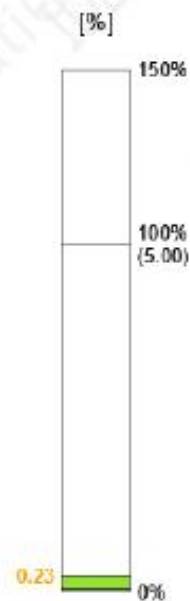

Project:
Project no:
Author:

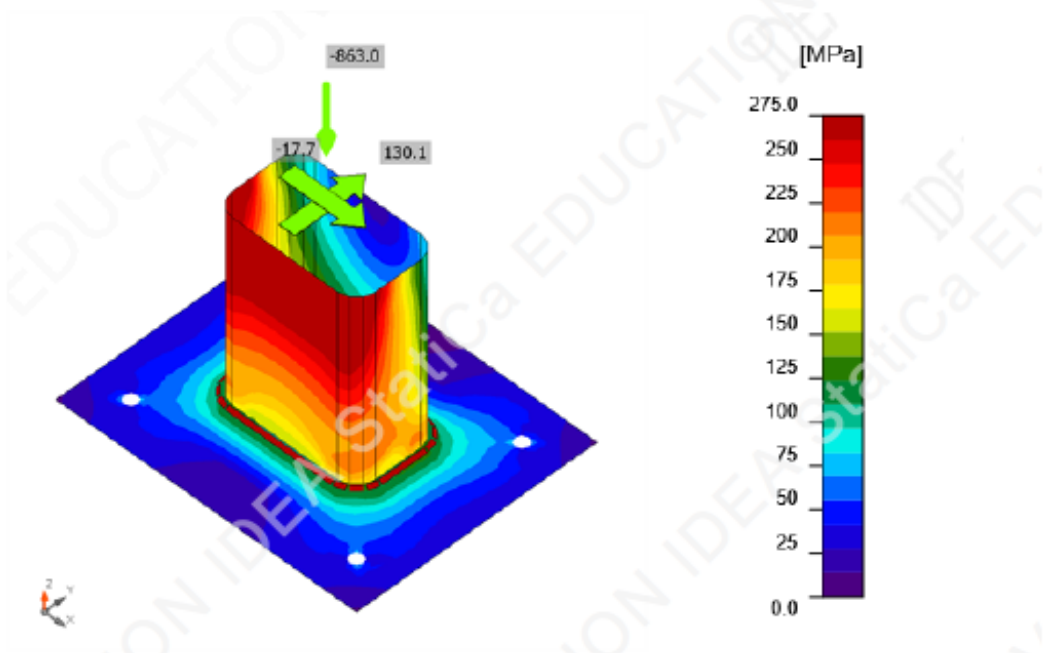

Equivalent stress, LE1

anchors

Shape	Item	Loads	N_{Ed} [kN]	V_{Ed} [kN]	$N_{Rd,c}$ [kN]	$V_{Rd,cp}$ [kN]	U_t [%]	U_s [%]	U_{ts} [%]	Status
	A1	LE1	3.4	0.0	243.0	343.2	7.8	0.0	2.2	OK
	A2	LE1	6.4	0.0	243.0	343.2	9.0	0.0	2.2	OK
	A3	LE1	3.1	0.0	243.0	343.2	7.8	0.0	2.2	OK
	A4	LE1	6.1	0.0	243.0	343.2	8.6	0.0	2.2	OK

Design data

Grade	$N_{Rd,s}$ [kN]	$V_{Rd,s}$ [kN]
M16 8.8 - 1	71.2	50.2

Symbol explanation

- N_{Ed} Tension force
- V_{Ed} Resultant of shear forces V_y, V_z in bolt
- $N_{Rd,c}$ Design resistance in case of concrete cone failure under tension load - EN1992-4 - Cl. 7.2.1.4
- $V_{Rd,cp}$ Design resistance in case of concrete pryout failure - EN1992-4 - Cl. 7.2.2.4
- U_t Utilization in tension
- U_s Utilization in shear
- U_{ts} Utilization in tension and shear
- $N_{Rd,s}$ Design tensile resistance of a fastener in case of steel failure - EN1992-4 - Cl. 7.2.1.3
- $V_{Rd,s}$ Design shear resistance in case of steel failure - EN1992-4 - Cl.7.2.2.3.1

Project:
Project no:
Author:



Welds (Plastic redistribution)

Item	Edge	Throat th. [mm]	Length [mm]	Loads	$\sigma_{w,Ed}$ [MPa]	ϵ_{pl} [%]	σ_{\perp} [MPa]	τ_{\parallel} [MPa]	τ_{\perp} [MPa]	Ut [%]	Ut _c [%]	Status
BP1	COL	5.0	525	LE1	397.1	0.3	-278.8	-5.4	184.4	98.1	97.0	OK

Design data

	β_w [-]	$\sigma_{w,Rd}$ [MPa]	0.9 σ [MPa]
S 275	0.85	404.7	309.8

Symbol explanation

ϵ_{pl}	Strain
$\sigma_{w,Ed}$	Equivalent stress
$\sigma_{w,Rd}$	Equivalent stress resistance
σ_{\perp}	Perpendicular stress
τ_{\parallel}	Shear stress parallel to weld axis
τ_{\perp}	Shear stress perpendicular to weld axis
0.9 σ	Perpendicular stress resistance - 0.9 \cdot f _u /γ _{M2}
β_w	Correlation factor EN 1993-1-8 tab. 4.1
Ut	Utilization
Ut _c	Weld capacity utilization

Concrete block

Item	Loads	c [mm]	A _{eff} [mm ²]	σ [MPa]	k _j [-]	F _{jd} [MPa]	Ut [%]	Status
CB 1	LE1	33	42459	21.0	3.00	33.5	62.6	OK

Symbol explanation

c	Bearing width
A _{eff}	Effective area
σ	Average stress in concrete
k _j	Concentration factor
F _{jd}	The ultimate bearing strength of the concrete block
Ut	Utilization

Shear in contact plane

Name	Loads	V _y [kN]	V _z [kN]	V _{Rd,y} [kN]	V _{Rd,z} [kN]	V _{c,Rd} [kN]	Ut [%]	Status
BP1	LE1	130.1	-17.7	222.7	222.7	0.0	59.0	OK

Project:
Project no:
Author:



Symbol explanation

V_y	Shear force in base plate V_y
V_z	Shear force in base plate V_z
$V_{Rd,y}$	Shear resistance
$V_{Rd,z}$	Shear resistance
$V_{c,Rd}$	Concrete bearing resistance
U_t	Utilization

Buckling

Buckling analysis was not calculated.

Code settings

Item	Value	Unit	Reference
YM0	1.00	-	EN 1993-1-1: 6.1
YM1	1.00	-	EN 1993-1-1: 6.1
YM2	1.25	-	EN 1993-1-1: 6.1
YM3	1.25	-	EN 1993-1-8: 2.2
Yc	1.50	-	EN 1992-1-1: 2.4.2.4
γ_{inst}	1.20	-	EN 1992-4: Table 4.1
Joint coefficient β_j	0.67	-	EN 1993-1-8: 6.2.5
Effective area - influence of mesh size	0.10	-	
Friction coefficient - concrete	0.25	-	EN 1993-1-8
Friction coefficient in slip-resistance	0.30	-	EN 1993-1-8 tab 3.7
Limit plastic strain	0.05	-	EN 1993-1-5
Weld stress evaluation	Plastic redistribution		
Detailing	No		
Distance between bolts [d]	2.20	-	EN 1993-1-8: tab 3.3
Distance between bolts and edge [d]	1.20	-	EN 1993-1-8: tab 3.3
Concrete breakout resistance check	Both		EN 1992-4: 7.2.1.4 and 7.2.2.5
Use calculated a_b in bearing check.	Yes		EN 1993-1-8: tab 3.4
Cracked concrete	Yes		EN 1992-4
Local deformation check	No		CIDECT DG 1, 3 - 1.1
Local deformation limit	0.03	-	CIDECT DG 1, 3 - 1.1
Geometrical nonlinearity (GMNA)	No		Analysis with large deformations for hollow section joints
Braced system	No		EN 1993-1-8: 5.2.2.5

H x B mm	T mm	M kg/m	A mm ² x 10 ²	A _L m ² /m	I _x mm ⁴ x 10 ⁴	W _x mm ³ x 10 ³	W _m mm ³ x 10 ³	I _y mm x 10	I _y mm ⁴ x 10 ⁴	W _y mm ³ x 10 ³	W _m mm ³ x 10 ³	I _y mm x 10	I _y mm ⁴ x 10 ⁴	W _y mm ³ x 10 ³
180x120	4.0	18.00	22.95	0.586	1049.97	116.66	139.97	6.76	563.81	93.97	106.17	4.96	1160.17	154.55
180x120	5.0	22.30	28.36	0.583	1277.37	141.93	171.52	6.71	683.97	11.00	129.95	4.91	1423.83	187.84
180x120	6.0	26.40	33.63	0.579	1491.34	165.70	201.71	6.66	796.30	132.72	152.65	4.87	1676.88	219.13
180x120	7.1	30.50	38.85	0.569	1675.73	186.19	229.41	6.57	895.15	149.19	173.75	4.80	1949.25	250.49
180x120	8.0	34.00	43.24	0.566	1835.33	203.93	253.14	6.51	978.44	163.07	191.57	4.76	2156.35	274.82
180x120	8.8	36.90	47.04	0.562	1967.28	218.59	273.19	6.47	1047.00	174.50	206.61	4.72	2332.35	295.13

Tablica 4.3.1. Prikaz površina poprečnog presjeka

Minimalna potrebna površina presjeka pri utjecaju tlačne sile:

$$A_{\min} = \frac{N_{cr} \cdot \gamma_{m0}}{f_y} = \frac{863}{27,5} = 31,38 \text{ cm}^2$$

$$31,38 \text{ cm}^2 < 43,24 \text{ cm}^2$$

Presjek zadovoljava.

5.4. Spoj Temelj – gornji pojas

Project:
Project no:
Author:



Project data

Project name
Project number
Author
Description
Date 9/14/2021
Design code EN

Material

Steel S 275
Concrete C25/30

Project:
Project no:
Author:



Project item CON1

Design

Name: CON1
Description:
Analysis: Stress, strain/ simplified loading

Beams and columns

Name	Cross-section	β - Direction [°]	γ - Pitch [°]	α - Rotation [°]	Offset ex [mm]	Offset ey [mm]	Offset ez [mm]	Forces in
COL	1 - RHS120/80/5.0	0.0	-90.0	0.0	0	0	0	Node

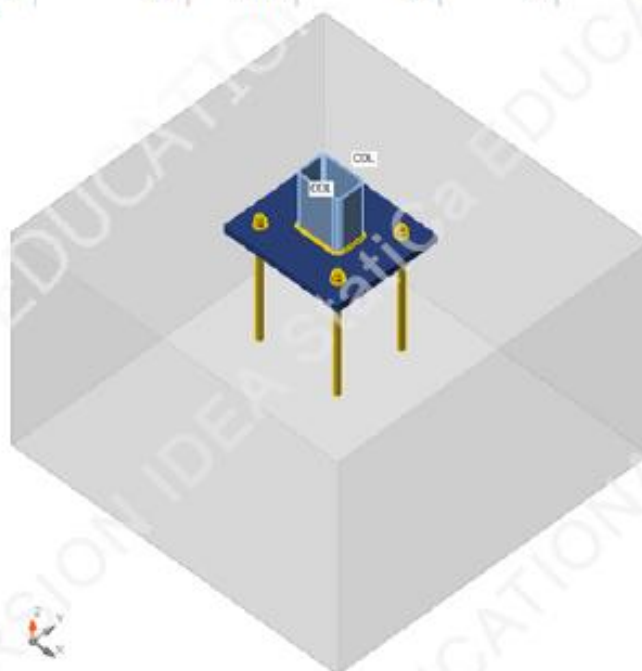

Cross-sections

Name	Material
1 - RHS120/80/5.0	S 275

Anchors

Name	Bolt assembly	Diameter [mm]	f_u [MPa]	Gross area [mm ²]
M16 8.8	M16 8.8	16	800.0	201

Load effects (equilibrium not required)

Name	Member	N [kN]	Vy [kN]	Vz [kN]	Mx [kNm]	My [kNm]	Mz [kNm]
LE1	COL	24.0	19.1	-301.1	0.0	0.0	0.0

Project:

Project no.:

Author:

**Foundation block**

Item	Value	Unit
CB 1		
Dimensions	880 x 920	mm
Depth	600	mm
Anchor	M16 8.8	
Anchoring length	300	mm
Shear force transfer	Friction	

Check**Summary**

Name	Value	Status
Analysis	100.0%	OK
Plates	0.0 < 5.0%	OK
Anchors	32.8 < 100%	OK
Welds	25.5 < 100%	OK
Concrete block	Not calculated	
Shear	56.2 < 100%	OK
Buckling	Not calculated	

Plates

Name	Thickness [mm]	Loads	σ_{Ed} [MPa]	ϵ_{pl} [%]	σ_{cEd} [MPa]	Status
COL	20.0	LE1	72.9	0.0	0.0	OK
BP1	20.0	LE1	126.3	0.0	0.0	OK

Design data

Material	f_y [MPa]	ϵ_{lim} [%]
S 275	275.0	5.0

Symbol explanation

ϵ_{pl}	Strain
σ_{Ed}	Eq. stress
σ_{cEd}	Contact stress
f_y	Yield strength
ϵ_{lim}	Limit of plastic strain

Project:
Project no:
Author:

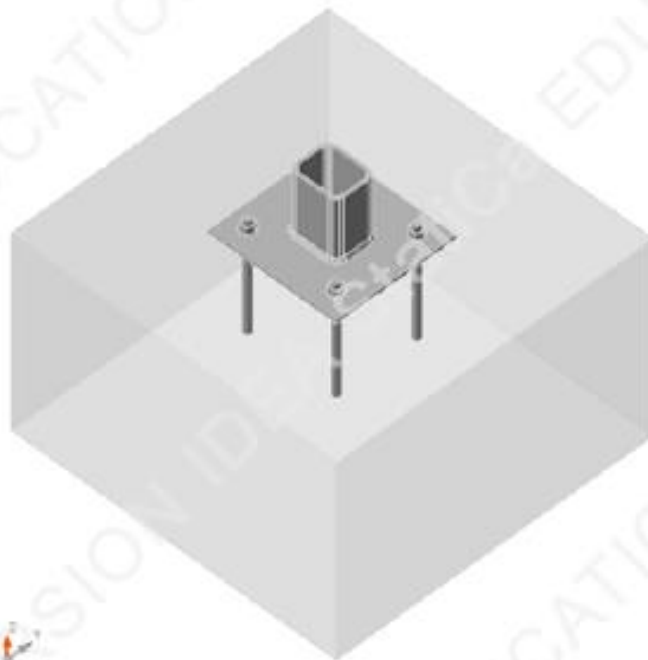

Overall check, LE1

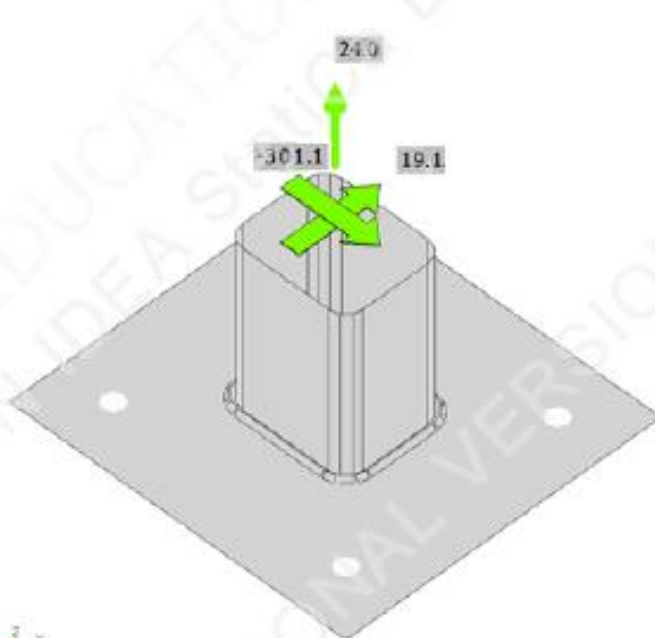

Strain check, LE1

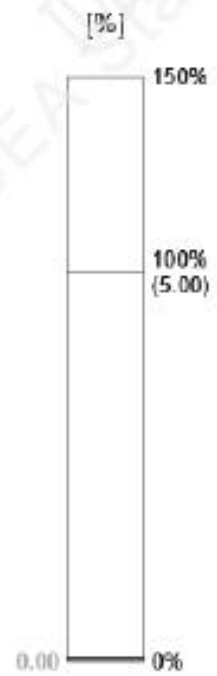

Project:
Project no:
Author:

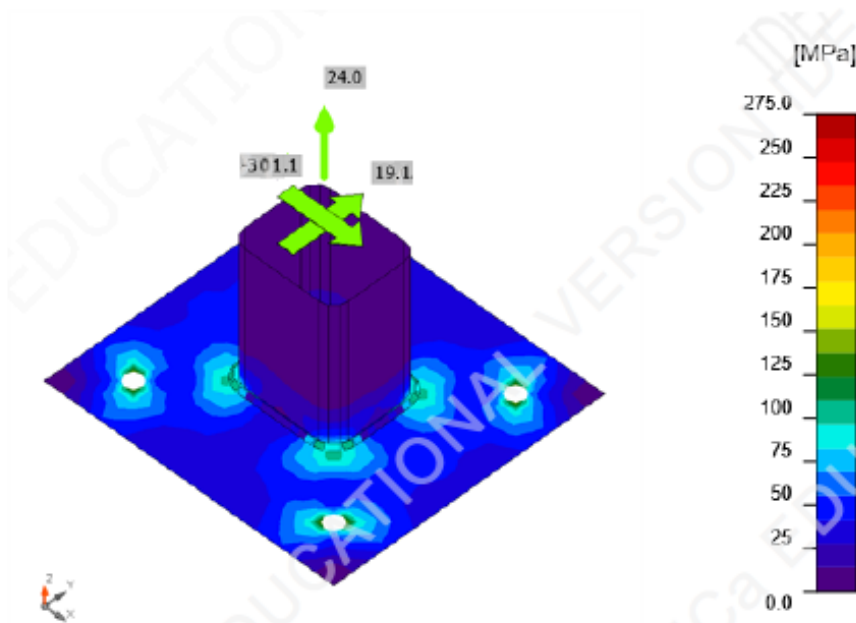

Equivalent stress, LE1

Anchors

Shape	Item	Loads	N_{Ed} [kN]	V_{Ed} [kN]	$N_{Rd,c}$ [kN]	$V_{Rd,cp}$ [kN]	U_{t_t} [%]	U_{t_s} [%]	$U_{t_{ts}}$ [%]	Status
	A1	LE1	12.0	0.0	146.4	351.7	32.8	0.0	18.8	OK
	A2	LE1	12.0	0.0	146.4	351.7	32.8	0.0	18.8	OK
	A3	LE1	11.9	0.0	146.4	351.7	32.8	0.0	18.8	OK
	A4	LE1	12.0	0.0	146.4	351.7	32.8	0.0	18.8	OK

Design data

Grade	$N_{Rd,s}$ [kN]	$V_{Rd,s}$ [kN]
M22 10.9 - 1	184.0	101.0

Symbol explanation

- N_{Ed} Tension force
- V_{Ed} Resultant of shear forces V_y, V_z in bolt
- $N_{Rd,c}$ Design resistance in case of concrete cone failure under tension load - EN1992-4 - Cl. 7.2.1.4
- $V_{Rd,cp}$ Design resistance in case of concrete pryout failure - EN1992-4 - Cl. 7.2.2.4
- U_{t_t} Utilization in tension
- U_{t_s} Utilization in shear
- $U_{t_{ts}}$ Utilization in tension and shear
- $N_{Rd,s}$ Design tensile resistance of a fastener in case of steel failure - EN1992-4 - Cl. 7.2.1.3
- $V_{Rd,s}$ Design shear resistance in case of steel failure - EN1992-4 - Cl. 7.2.2.3.1

Project:
Project no:
Author:



Welds (Plastic redistribution)

Item	Edge	Throat th. [mm]	Length [mm]	Loads	$\sigma_{w,Ed}$ [MPa]	ϵ_{pl} [%]	σ_{\perp} [MPa]	τ_{\parallel} [MPa]	τ_{\perp} [MPa]	Ut [%]	Ut _c [%]	Status
BP1	COL	3.5	474	LE1	103.2	0.0	70.9	-39.9	-16.8	25.5	13.0	OK

Design data

	β_w [-]	$\sigma_{w,Rd}$ [MPa]	0.9 σ [MPa]
S 275	0.85	404.7	309.6

Symbol explanation

ϵ_{pl}	Strain
$\sigma_{w,Ed}$	Equivalent stress
$\sigma_{w,Rd}$	Equivalent stress resistance
σ_{\perp}	Perpendicular stress
τ_{\parallel}	Shear stress parallel to weld axis
τ_{\perp}	Shear stress perpendicular to weld axis
0.9 σ	Perpendicular stress resistance - 0.9* f_u / γ_{M2}
β_w	Corelation factor EN 1993-1-8 tab. 4.1
Ut	Utilization
Ut _c	Weld capacity utilization

Shear in contact plane

Name	Loads	V _y [kN]	V _z [kN]	V _{Rd,y} [kN]	V _{Rd,z} [kN]	V _{c,Rd} [kN]	Ut [%]	Status
BP1	LE1	1.9	-3.1	6.5	6.5	0.0	56.2	OK

Symbol explanation

V _y	Shear force in base plate V _y
V _z	Shear force in base plate V _z
V _{Rd,y}	Shear resistance
V _{Rd,z}	Shear resistance
V _{c,Rd}	Concrete bearing resistance
Ut	Utilization

Buckling

Buckling analysis was not calculated.

Code settings

Item	Value	Unit	Reference
YM0	1.00	-	EN 1993-1-1: 6.1
YM1	1.00	-	EN 1993-1-1: 6.1
YM2	1.25	-	EN 1993-1-1: 6.1
YM3	1.25	-	EN 1993-1-8: 2.2
YC	1.50	-	EN 1992-1-1: 2.4.2.4

Project:
Project no:
Author:



Item	Value	Unit	Reference
Yinst	1.20	-	EN 1992-4: Table 4.1
Joint coefficient β_j	0.67	-	EN 1993-1-8: 6.2.5
Effective area - influence of mesh size	0.10	-	
Friction coefficient - concrete	0.25	-	EN 1993-1-8
Friction coefficient in slip-resistance	0.30	-	EN 1993-1-8 tab 3.7
Limit plastic strain	0.05	-	EN 1993-1-5
Weld stress evaluation	Plastic redistribution		
Detailing	No		
Distance between bolts [d]	2.20	-	EN 1993-1-8: tab 3.3
Distance between bolts and edge [d]	1.20	-	EN 1993-1-8: tab 3.3
Concrete breakout resistance check	Both		EN 1992-4: 7.2.1.4 and 7.2.2.5
Use calculated ob in bearing check.	Yes		EN 1993-1-8: tab 3.4
Cracked concrete	Yes		EN 1992-4
Local deformation check	No		CIDECT DG 1, 3 - 1.1
Local deformation limit	0.03	-	CIDECT DG 1, 3 - 1.1
Geometrical nonlinearity (GMNA)	Yes		Analysis with large deformations for hollow section joints
Braced system	No		EN 1993-1-8: 5.2.2.5

Budući da se prenosi tlačna sila, spoj unutarnejeg pojasa usvojen je isti kao i spoj vanjskog pojasa rešetke.

NAPOMENA: Pri dimenzioniranju betonskog temelja potrebno je provjeriti gnječenje betona ispod podložne pločice.

H x B mm	T mm	M kg/m	A mm ² x 10 ²	A _s m ² /m	I _y mm ⁴ x 10 ⁴	W _y mm ³ x 10 ³	W _{pl} mm ³ x 10 ³	I _z mm x 10	I _y mm ⁴ x 10 ⁴	W _y mm ³ x 10 ³	W _{pl} mm ³ x 10 ³	I _z mm x 10	I _x mm ⁴ x 10 ⁴	W _x mm ³ x 10 ³
120x80	2.5	7.53	9.59	0.391	195.75	32.63	39.07	4.52	105.19	26.30	29.65	3.31	215.82	43.23
120x80	3.0	8.96	11.41	0.390	230.20	38.37	46.20	4.49	123.43	30.86	35.02	3.29	255.47	50.80
120x80	4.0	11.70	14.95	0.386	294.59	49.10	59.77	4.44	157.29	39.32	45.23	3.24	331.24	64.93
120x80	5.0	14.40	18.36	0.383	353.14	58.86	72.45	4.39	187.78	46.94	54.74	3.20	402.27	77.77
120x80	6.0	17.00	21.63	0.379	406.06	67.68	84.25	4.33	215.03	53.76	63.55	3.15	468.54	89.40
120x80	7.1	19.40	24.65	0.369	442.06	73.68	93.59	4.24	234.41	58.60	70.68	3.08	535.11	99.99
120x80	8.0	21.40	27.24	0.366	475.83	79.31	101.97	4.18	251.66	62.92	76.93	3.04	584.04	108.01
120x80	8.8	23.10	29.44	0.362	501.79	83.63	108.75	4.13	264.84	66.21	81.97	3.00	623.54	114.33
120x80	10.0	25.60	32.57	0.357	534.14	89.02	117.82	4.05	281.14	70.29	88.68	2.94	675.59	122.44

Tablica 4.4.1. Prikaz površina poprečnog presjeka

Minimalna potrebna površina presjeka pri utjecaju tlačne sile:

$$A_{\min} = \frac{N_{cr} \cdot \gamma_{m0}}{f_y} = \frac{310}{27,5} = 11,27 \text{ cm}^2$$

$$11,27 \text{ cm}^2 < 14,40 \text{ cm}^2$$

Presjek zadovoljava.

5.5. Montažni priključak na gornjem i donjem pojasu

$N = 158,05 \text{ kN}$ (vlak)

$V_z = 0,40 \text{ kN}$

1) Osnovni materijal:

Čelik S275

$$f_y = 275 \text{ N/mm}^2$$

$$E = 210 \text{ GPa}$$

2) Kontrola vara

- dužina vara pojasnice:

$$l_p = 2 \cdot 180 + 2 \cdot 100 = 560 \text{ (mm)}$$

- max debljina vara s obzirom na debljinu stijenke nosača

$$a_{\max} = 0.7 \cdot t_{\min}$$

$$t_{\min} = 5 \text{ mm}$$

$$\Rightarrow a_{\max} = 0.7 \cdot t_{\min} = 0.7 \cdot 5 = 3.5 \text{ mm}$$

$$a_{\text{odabrano}} = 3 \text{ mm}$$

Za pretpostavljeni var $a = 3 \text{ (mm)}$:

$F_{w,Rd} = \frac{F_{w,Rk}}{\gamma_{Mw}}$

pri čemu se $F_{w,Rk}$ dobije iz tablice

OTPORNOST ZAVARA U UVALI									
$F_{w,Rk} = \frac{f_u}{\sqrt{3} \cdot \beta_w} \cdot a \cdot L$ <p>a - debljina zavora L - dužina zavora β_w - koeficijent korelacije</p>									
OTPORNOST ZAVARA $F_{w,Rk}$ ZA ZAVAR DUŽINE 100 mm									
Debljina zavora a [mm]	3	4	5	6	7	8	9	10	12
Fe 360 $\beta_w = 0.8$	77.9	103.9	129.9	155.9	181.9	207.8	233.8	259.8	311.8
Fe 430 $\beta_w = 0.85$	87.6	116.8	146.0	175.2	204.4	233.7	262.9	292.1	350.5
Fe 510 $\beta_w = 0.9$	98.1	130.9	163.6	196.3	229.0	261.7	294.4	327.2	392.6
Za dužinu zavora različitu od 100 mm, gornje vrijednosti množiti s L/100.									

Tablica 4.5.1. Otpornost zavora u uvali

$$\text{- uzdužna sila: } F_{w,Rd} = \frac{F_{w,Rk}}{1.25} \cdot \frac{L}{100} = \frac{87.6}{1.25} \cdot \frac{560}{100} = 392.45 \text{ kN}$$

uvjet nosivosti:

$$N = F_{w,Sd} \leq F_{w,Rd}$$

$$158,05 \text{ kN} \leq 392,45 \text{ kN}$$

$$\text{- poprečna sila: } F_{w,Rd} = \frac{F_{w,Rk}}{1.25} \cdot \frac{L}{100} = \frac{87.6}{1.25} \cdot \frac{200}{100} = 140,16 \text{ kN}$$

uvjet nosivosti:

$$N_p = F_{w,Sd} \leq F_{w,Rd}$$

$$0,40 \leq 140,16 \text{ kN}$$

→ **Var a=3 mm** zadovoljava

3) Proračun vijaka

Pretpostavljeni vijci: M 16, k.v. 8.8 , n=4 vijka

- udaljenost c_{min} vijaka od ruba pojasnice:

$$c_{min} = 2 \cdot d + a\sqrt{2} = 2 \cdot 16 + 3\sqrt{2} = 35,46 \text{ mm}$$

Usvojeno $c = 40 \text{ mm}$.

- **otpornost vijaka na vlak:**

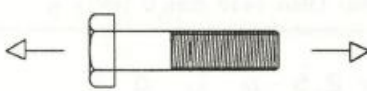
KARAKTERISTIČNA VLAČNA OTPORNOST ZA JEDAN VIJAK U [kN]									
		 $F_{t,Rk} = 0.9 \cdot f_{ub} \cdot A_s$							
PROMJER VIJKA d [mm]	KV.	12	16	20	22	24	27	30	36
VLAČNA	4.6	30.3	56.5	88.2	109.1	127.1	165.2	202.0	294.1
OTPORNOST $F_{t,Rk}$ [kN]	5.6	37.9	70.7	110.3	136.4	158.9	206.6	252.5	367.7
	8.8	60.7	113.0	176.4	218.2	254.2	330.5	403.9	588.2
	10.9	75.9	141.3	220.5	272.7	317.7	413.1	504.9	735.3

Tablica 4.5.2. Karakteristična vlačna otpornost za jedan vijak

$$F_{t,Rd} = \frac{F_{t,Rk}}{\gamma_{M1}} = \frac{113,0}{1,25} = 90,4 \text{ kN}$$

uvjet nosivosti:

$$F_{t,Rd} > F_{t,Sd} / 4$$

$$90,4 > 158,05/4$$

$$90,4 \text{ kN} > 39,51 \text{ kN}$$

- otpornost vijaka na posmik:

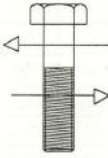
KARAKTERISTIČNA POSMIČNA OTPORNOST ZA JEDAN VIJAK I JEDNU POSMIČNU POVRŠINU U [kN]									
		$F_{v,Rk} = C_1 \cdot f_{ub} \cdot A_s$							
		gdje je: $C_1=0.6$ za klasu 4.6, 5.6 i 8.8 $C_1=0.5$ za klasu 4.8, 5.8, 6.8 i 10.9							
PROMJER VIJKA	d [mm]	12	16	20	22	24	27	30	36
PROMJER RUPE	d ₀ [mm]	13	18	22	24	26	30	33	39
POVRŠINA JEZGRE VIJKA	A _s [mm ²]	84.3	157	245	303	353	459	561	817
POSMIČNA OTPORNOST F _{v,Rk} U [kN]	KV.								
	4.6	20.2	37.7	58.8	72.7	84.7	110.2	134.6	196.1
	5.6	25.3	47.1	73.5	90.9	105.9	137.7	168.3	245.1
	8.8	40.5	75.4	117.6	145.4	169.4	220.3	269.3	392.2
	10.9	42.2	78.5	122.5	151.5	176.5	229.5	280.5	408.5

Tablica 4.5.3. Karakteristična posmična otpornost za jedan vijak i jednu površinu

$$F_{v,Rd} = \frac{F_{v,Rk}}{\gamma_{M1}} =$$

$$= \frac{78,5}{1,25} = 62,8 \text{ kN}$$

uvjet nosivosti:

$$F_{v,Rd} > F_{v,Sd}$$

$$62,8 \text{ kN} > F_{v,Sd} = V_{Sd} / 4 = 0,4/4 = 0,1 \text{ kN}$$

- interakcija uzdužne i odrezne sile na vijak:

$$\frac{F_{v,Sd}}{F_{v,Rd}} + \frac{F_{t,Sd}}{1,4 \cdot F_{t,Rd}} \leq 1$$

$$\frac{0,1}{62,8} + \frac{39,51}{1,4 \cdot 90,4} \leq 1$$

$$0,31 < 1$$

→ Vijci zadovoljavaju

4) Proračun ploče

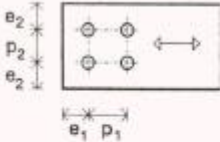
KARAKTERISTIČNE VRIJEDNOSTI OTPORNOSTI PO JEDNOM VIJKU ZA PREPORUČENE DETALJE I DEBLJINU LIMA $t=10$ mm U [kN]									
		$F_{d,Rk} = 2.5 \cdot \alpha \cdot f_u \cdot d \cdot t$ $\alpha = \min \left(\frac{e_1}{3d_0}; \frac{p_1}{3d_0} - \frac{1}{4}; \frac{f_{ub}}{f_u}; 1.0 \right)$							
PROMJER VIJKA	d [mm]	12	16	20	22	24	27	30	36
PROMJER RUPE	d ₀ [mm]	13	18	22	24	26	30	33	39
KOMPAKTNI DETALJ	e ₁	20	27.5	35	37.5	40	45	50	60
	p ₁ , p ₂	30	40	50	55	60	67.5	75	90
	e ₂	20	25	30	32.5	35	40	45	55
	Fe 360	55.4	70.7	91.4	101.8	110.8	121.5	136.4	166.2
	Fe 430	66.2	84.4	109.1	121.5	132.3	145.1	162.9	198.5
	Fe 510	78.5	100.1	129.4	144.1	156.9	172.1	193.2	235.4
PREPORUČENE VRIJEDNOSTI	e ₁	30	40	50	55	60	70	75	90
	p ₁ , p ₂	40	55	70	75	80	90	100	120
	e ₂	25	30	40	45	50	55	60	70
	Fe 360	83.1	106.7	136.4	151.3	166.2	182.3	204.5	249.2
	Fe 430	99.2	127.4	162.9	180.7	198.5	217.7	244.3	297.7
	Fe 510	117.7	151.1	193.2	214.3	235.4	258.2	289.8	353.1
VELIKA NOSIVOST	e ₁	40	55	70	75	80	90	100	120
	p ₁ , p ₂	50	70	85	95	100	115	130	150
	e ₂	35	50	60	65	70	80	90	110
	Fe 360	108.0	144.0	180.0	198.0	216.0	243.0	270.0	324.0
	Fe 430	129.0	172.0	215.0	236.5	258.0	290.3	322.5	387.0
	Fe 510	153.0	204.0	255.0	280.5	306.0	344.3	382.5	459.0
Za međuvrijednosti α potrebno je karakterističnu vrijednost $F_{d,Rk}$ linearno interpolirati. Za druge debljine ploče t_p potrebno je vrijednosti iz tablice pomnožiti s $t_p / 10$.									

Tablica 4.5.4. Karakteristične vrijednosti otpornosti po jednom vijku za preporučene detalje i debljinu lima 10 mm

$$a = h + (c + e_1) = 180 + (40 + 40) = 260 \text{ mm}$$

$$b_{pl,\min} = 2 \cdot e_2 + p_2 = 2 \cdot 30 + 55 = 115 \text{ mm}$$

$$b_{pl,\min} = b + 2 \cdot a \cdot \sqrt{2} + 20 \text{ mm} = 100 + 2 \cdot 3 \cdot \sqrt{2} + 20 = 128.49 \text{ mm}$$

Odabrane dimenzije ploče: 200x300 mm

Proračun debljine ploče:

- **pritisak po omotaču rupe osnovnog materijala:**

$$F_{v,Sd} = V_{Sd} / 4 = 0,1 \text{ kN} \equiv F_{b,Sd}$$

$$F_{b,Rd} = \frac{F_{b,Rk}}{1,25} \cdot \frac{t_{pl}}{10} = \frac{127,4}{1,25} \cdot \frac{t_{pl}}{10} = F_{b,Sd} = 0,1 \text{ kN}$$

$$\Rightarrow t_{pl}^{\min} = 0,01 \text{ mm}$$

- **savijanje ploče od vlačnih vijaka:**

$$M_{Sd} = F_{t,Sd} \cdot c = 39,51 \cdot 2 \cdot 0,05 = 3,95 \text{ kNm}$$

$$M_{Sd} \leq \frac{W_{\min} \cdot f_y}{1,1} \Rightarrow W_{\min} = \frac{1,1 \cdot M_{Sd}}{f_y} = \frac{b_{pl} \cdot t_{pl}^2}{6}$$

$$t_{pl}^{\min} = \sqrt{\frac{1,1 \cdot M_{Sd} \cdot 6}{b_{pl} \cdot f_y}} = \sqrt{\frac{1,1 \cdot 3,95 \cdot 6}{30 \cdot 27,5}} = 0,178 \text{ cm}$$

$$\rightarrow t_{pl,odabrano} = 10 \text{ mm}$$

Usvojene dimenzije ploče: 300x380x10 mm

5.6. Montažni priključak na vertikalama i dijagonalama

$$N = 138,97 \text{ kN (vlak)}$$

$$V_z = 0,79 \text{ kN}$$

1) Osnovni materijal:

Čelik S275

$$f_y = 275 \text{ N/mm}^2$$

$$E = 210 \text{ GPa}$$

2) Kontrola vara

- dužina vara pojasnice:

$$l_p = 4 \cdot 90 = 360 \text{ (mm)}$$

- max debljina vara s obzirom na debljinu stijenke nosača

$$a_{\max} = 0.7 \cdot t_{\min}$$

$$t_{\min} = 5 \text{ mm}$$

$$\Rightarrow a_{\max} = 0.7 \cdot t_{\min} = 0.7 \cdot 5 = 3.5 \text{ mm}$$

$$a_{\text{odabrano}} = 3 \text{ mm}$$

Za pretpostavljeni var $a = 3 \text{ (mm)}$:

$$\text{- uzdužna sila: } F_{w,Rd} = \frac{F_{w,Rk}}{1.25} \cdot \frac{L}{100} = \frac{87.6}{1.25} \cdot \frac{360}{100} = 252,29 \text{ kN}$$

uvjet nosivosti:

$$N = F_{w,Sd} \leq F_{w,Rd}$$

$$138,97 \text{ kN} \leq 252,29 \text{ kN}$$

$$\text{- poprečna sila: } F_{w,Rd} = \frac{F_{w,Rk}}{1.25} \cdot \frac{L}{100} = \frac{87.6}{1.25} \cdot \frac{180}{100} = 126,14 \text{ kN}$$

uvjet nosivosti:

$$N_p = F_{w,Sd} \leq F_{w,Rd}$$

$$0,79 \leq 126,14 \text{ kN}$$

→ **Var $a = 3 \text{ mm}$** zadovoljava

3) Proračun vijaka

Pretpostavljeni vijci: M 16, k.v. 8.8, n=4 vijka

- udaljenost c_{\min} vijaka od ruba pojasnice:

$$c_{\min} = 2 \cdot d + a\sqrt{2} = 2 \cdot 16 + 3\sqrt{2} = 35,46 \text{ mm}$$

Usvojeno $c = 40 \text{ mm}$.

- **otpornost vijaka na vlak:**

$$F_{t,Rd} = \frac{F_{t,Rk}}{\gamma_{M1}} = \frac{113,0}{1,25} = 90,4 \text{ kN}$$

uvjet nosivosti:

$$F_{t,Rd} > F_{t,Sd} / 4$$

$$90,4 > 138,97/4$$

$$90,4 \text{ kN} > 34,74 \text{ kN}$$

- **otpornost vijaka na posmik:**

$$F_{v,Rd} = \frac{F_{v,Rk}}{\gamma_{M1}} =$$

$$= \frac{78,5}{1,25} = 62,8 \text{ kN}$$

uvjet nosivosti:

$$F_{v,Rd} > F_{v,Sd}$$

$$62,8 \text{ kN} > F_{v,Sd} = V_{Sd} / 4 = 0,74/4 = 0,19 \text{ kN}$$

- interakcija uzdužne i odrezne sile na vijak:

$$\frac{F_{V,Sd}}{F_{V,Rd}} + \frac{F_{t,Sd}}{1,4 \cdot F_{t,Rd}} \leq 1$$

$$\frac{0,19}{62,8} + \frac{34,74}{1,4 \cdot 90,4} \leq 1$$

$$0,28 < 1$$

→ Vijci zadovoljavaju

4) Proračun ploče

$$a = h + (c + e_1) = 90 + (40 + 40) = 170 \text{ mm}$$

$$b_{pl,\min} = 2 \cdot e_2 + p_2 = 2 \cdot 30 + 55 = 115 \text{ mm}$$

$$b_{pl,\min} = b + 2 \cdot a \cdot \sqrt{2} + 20 \text{ mm} = 90 + 2 \cdot 170 \cdot \sqrt{2} + 20 = 118,49 \text{ mm}$$

Odabrane dimenzije ploče: 200x200 mm

Proračun debljine ploče:

- **pritisak po omotaču rupe osnovnog materijala:**

$$F_{v,Sd} = V_{Sd} / 4 = 0,19 \text{ kN} \equiv F_{b,Sd}$$

$$F_{b,Rd} = \frac{F_{b,Rk}}{1,25} \cdot \frac{t_{pl}}{10} = \frac{127,4}{1,25} \cdot \frac{t_{pl}}{10} = F_{b,Sd} = 0,19 \text{ kN}$$

$$\Rightarrow t_{pl}^{\min} = 0,02 \text{ mm}$$

- **savijanje ploče od vlačnih vijaka:**

$$M_{Sd} = F_{t,Sd} \cdot c = 34,74 \cdot 2 \cdot 0,05 = 3,47 \text{ kNm}$$

$$M_{Sd} \leq \frac{W_{\min} \cdot f_y}{1,1} \Rightarrow W_{\min} = \frac{1,1 \cdot M_{Sd}}{f_y} = \frac{b_{pl} \cdot t_{pl}^{\min}}{6}$$

$$t_{pl}^{\min} = \sqrt{\frac{1,1 \cdot M_{Sd} \cdot 6}{b_{pl} \cdot f_y}} = \sqrt{\frac{1,1 \cdot 3,47 \cdot 6}{20 \cdot 27,5}} = 0,204 \text{ cm}$$

$$\rightarrow t_{pl,odabrano} = 10 \text{ mm}$$

Usvojene dimenzije ploče: 300x300x10 mm

6. PRORAČUN PODNE STAKLENE KONSTRUKCIJE

6.1. Popis normi za proračun staklenih elemenata

EN 572 Glass in Building - Basic soda lime silicate glass products

EN 572-1 Glass in Building - Basic soda lime silicate glass products - Part 1:

Definitions and general physical and mechanical properties EN 1036 Glass in building - Mirrors from silver coated float glass for internal use

EN 1096 Glass in building - Coated glass

EN 1296 Glass in building - Insulating glass units

EN 1748-1 Glass in Building - Basic borosilicate glass products

EN 1748-1-1 Glass in Building - Basic borosilicate glass products - Part 1:

Definitions and general physical and mechanical properties

EN 1748-2 Glass in Building - Basic glass ceramics products

EN 1748-2-1 Glass in Building - Basic glass ceramics products - Part 1:

Definitions and general physical and mechanical properties

EN 1863 Glass in building - Heat strengthened soda lime silicate glass

EN 1863-1 Glass in building - Heat strengthened soda lime silicate glass - Part 1:

Definition and description

EN 1990 Eurocode – Basis of

structural design EN 1991 Actions on

structures

EN 1991-1-4 Wind

Geotechnical design

EN 1998 Design of structures for earthquake

EN 12150 Glass in building - Thermally toughened soda lime silicate safety glass

EN 12150-1 Glass in building - Thermally toughened soda lime silicate safety

glass - Part 1: Definition and description

EN 12337 Glass in building - Chemically strengthened soda lime silicate glass

EN 12337-1 Glass in building - Chemically strengthened soda lime silicate glass
- Part 1: Definition and description

EN ISO 12543 Glass in building - Laminated and laminated safety glass

EN ISO 12543-1 Glass in building - Laminated and laminated safety glass -
Part 1: Definitions and description of component parts

EN 13024 Glass in building - Thermally toughened borosilicate safety glass

EN 13024-1 Glass in building - Thermally toughened borosilicate safety glass -
Part 1: Definition and description

prEN 13474-1 Glass in building - Determination of the strength of glass panes -
Part 1: Glass and glass products for fenestration

prEN 13474-2 Glass in building - Determination of the strength of glass panes -
Part 2: Common glass applications other than fenestration

**prEN 13474-3: Glass in building - Determination of the strength of glass
panes - Part 3: General method of calculation and determination of strength
of glass by testing.**

EN 14178 Glass in Building - Basic alkaline earth silicate glass products

EN 14178-1 Glass in Building - Basic alkaline earth silicate glass products -
Part 1: Definitions and general physical and mechanical properties

EN 14179 Glass in building - Heat soaked thermally toughened soda lime
silicate safety glass

EN 14179-1 Glass in building - Heat soaked thermally toughened soda lime
silicate safety glass - Part 1: Definition and description
EN 14321-1 Glass in
building - Thermally toughened alkaline earth silicate safety glass

EN 14321-1 Glass in building - Thermally toughened alkaline earth silicate
safety glass - Part 1: Definition and description

EN 14449 Glass in building - Laminated glass and laminated safety glass -
Evaluation of conformity/Product Standard

6.2. Proračun staklenog elementa

Staklo se oslanja na sekundarnu čeličnu konstrukciju, koja se sastoji od radijalno postavljenih konzolnih nosača na razmaku cca 2.5 m. Na svaki od tih konzolnih nosača dolaze vertikalne ograde, te s vanjske i unutarnje strane L profili koji tangencijalno povezuju konzolne nosače. Staklo ograde oslonjeno je na njih i vertikalne ograde (s 3 strane), dok staklo poda oslanja se na 4 brida. Predviđeno je lamelirano staklo za pod i za ogradu. Za pod 5x16mm, a ogradu 3x16mm, termički obrađenog stakla. Na slici 2. prikazan je 3D model jednog segmenta kružnog dijela. Polovinu kruga podijeljeno je na 12 dijelova ($\alpha=15^\circ$). Ravni dijelovi trebaju biti istog ili manjeg razmaka okvira $l \leq 2200\text{mm}$.

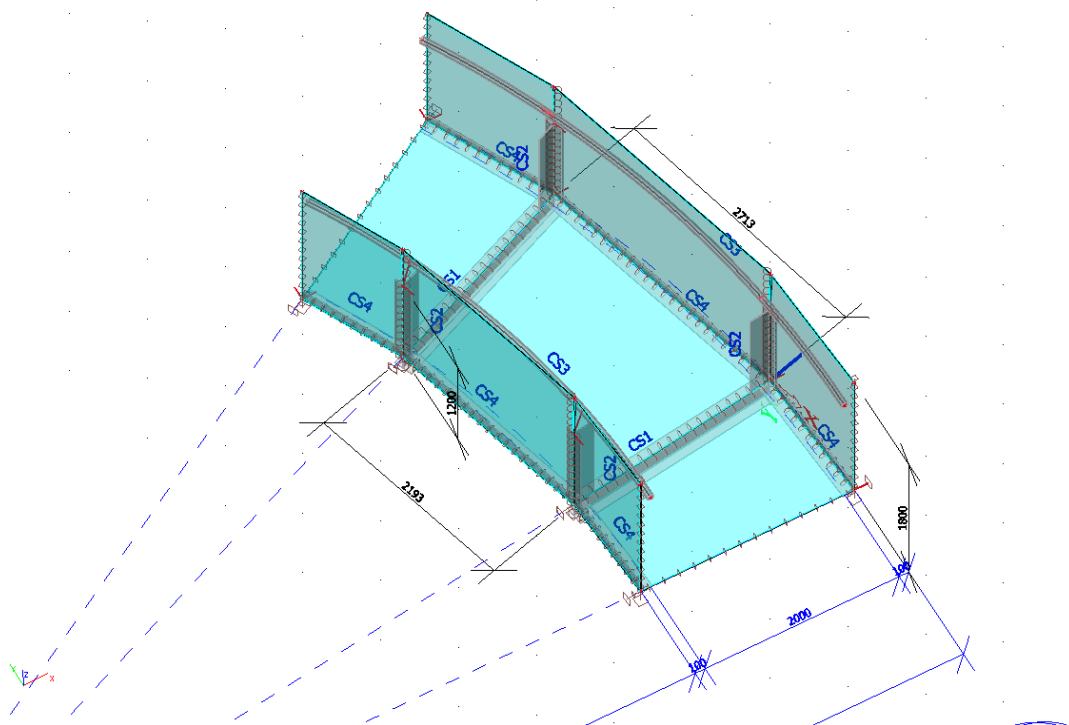

Slika 5.2.1. Tlocrtni prikaz staklenih elemenata

Zadatak je dimenzionirati podni element trapezastog oblika koji je oslonjen na čeličnu konstrukciju (sekundarne konstrukcije). Duljina duže stranice trapeza iznosi 2.671 metra, a kraće 2.149 metra.

6.2.1. Proračun prema Europskim normama

Pod je izveden od lameliranog stakla od 5 slojeva $d=5 \cdot 16\text{mm}$. Računska otpornost staklenih elemenata se izračunava prema izrazu:

$$f_{g;d} = \frac{k_{\text{mod}} \cdot k_{\text{sp}} \cdot f_{g;k}}{\gamma_{M,A}}$$

$f_{g,k}$ – karakteristična otpornost na savijanje

k_{mod} – faktor trajanja opterećenja

k_{sp} – faktor utjecaja površine

$\gamma_{M,A}$ – parcijalni faktor za staklo

$k_{\text{mod}} = 0.29$ za vlastitu težinu, $k_{\text{mod}} = 0.74$ za vjetar, $k_{\text{mod}} = 0.8$ za pokretno opterećenje, $k_{\text{mod}} = 0.43$ za snijeg

$$f_{g,d}(v.t.) = \frac{0,29 \cdot 1 \cdot 45}{1,8} = 7,25 \frac{N}{\text{mm}^2} = 7,25 \text{ MPa}$$

$$f_{g,d}(s) = 10,75 \text{ Mpa}$$

$$f_{g,d}(p.o.) = 20,0 \text{ Mpa}$$

$$f_{g,d}(vjetar) = 18,5 \text{ Mpa}$$

6.2.2. Proračun prema graničnim stanjima

GRANIČNO STANJE NOSIVOSTI

Kod proračuna prema graničnom stanju nosivosti mora biti dokazano da je maksimalno naprezanje (projektirana vrijednost djelovanja) manje od dopuštenog naprezanje (projektirane vrijednosti otpornosti).

Računsko opterećenje:

- 1) Snijeg – $q_s = 5.6 \text{ kN/m}^2$
- 2) Pokretno opterećenje = 5 kN/m^2
- 3) Vjetar - $q_w = 1,68 \text{ kN/m}^2$

Uvjet nosivosti :

$$\sigma_{\max} \leq f_{g;d}$$

Maksimalno vlačno naprezanje izračunava se prema izrazu:

$$\sigma_{\max} = k_1 \cdot \frac{A}{h^2} \cdot F_d$$

Dimenzije a i b su stranice panela (a mora biti manja dimenzija). Površina panela $A = a \cdot b$. Debljina panela označava se s h.

Odnos stranica je definiran: $\lambda = a / b$

Bezdimenzionalni koeficijent opterećenja:

$$p^* = \left(\frac{A}{4 \cdot h^2} \right)^2 \cdot \frac{F_d}{E}$$

Kako bi odredili vrijednost bezdimenzionalnog koeficijenta k_1 , koristimo se tablicom 5.2.2.1.

$\lambda=a/b$	p^*										
	0	1	2	3	5	10	20	50	100	200	300
1,0	0.268	0.261	0.244	0.223	0.190	0.152	0.135	0.130	0.129	0.128	0.128
0,9	0.287	0.278	0.258	0.234	0.197	0.155	0.137	0.131	0.130	0.129	0.129
0,8	0.304	0.295	0.273	0.247	0.205	0.159	0.138	0.131	0.130	0.130	0.130
0,7	0.314	0.306	0.285	0.261	0.218	0.165	0.140	0.130	0.129	0.129	0.129
0,6	0.314	0.309	0.294	0.274	0.235	0.176	0.143	0.129	0.127	0.126	0.126
0,5	0.300	0.298	0.290	0.279	0.253	0.197	0.151	0.128	0.124	0.123	0.122
0,4	0.268	0.268	0.266	0.262	0.252	0.221	0.171	0.129	0.119	0.116	0.116
0,3	0.217	0.217	0.217	0.216	0.215	0.208	0.189	0.141	0.116	0.107	0.105
0,2	0.149	0.149	0.149	0.149	0.149	0.149	0.148	0.140	0.123	0.100	0.091
0,1	0.075	0.075	0.075	0.075	0.075	0.075	0.075	0.075	0.075	0.074	0.073

Tablica 5.2.2.1. Tablica za određivanje koeficijenta k_1

$$\lambda = 2/2,713 = 0,74 \rightarrow \lambda = 0,7 \text{ (strana sigurnosti)}$$

U slučaju laminiranih elementa mora se uzeti u obzir PVB sloj čija je posmična čvrstoća bitno manja od čvrstoće stakla. U ovom slučaju govorimo o popustljivosti međusloja. Budući da je ovaj stakleni element sastavljen od više elemenata iste debljine, potrebno je izračunati efektivnu debljinu lameliranog stakla.

$$h_{ef;\sigma;j} = \sqrt{\frac{(h_{ef;w})^3}{(h_j + 2\varpi h_{m;j})}}$$

ω - koeficijent koji se kreće u vrijednosti od 0 do 1. 0 znači da nema prijenosa posmičnih naprezanja (nema veze između dva panela), a 1 označava potpuni prijenos posmičnih naprezanja (nema pomaka među panelima, kruti spoj).

h_i, h_j - debljine staklenih elemenata

$h_{m;j}$ - udaljenost od srednjeg panela do središta cjelokupnog laminiranog elementa

U tablici 5.2.2.2. Prikazane su neke vrijednosti efektivnih debljina od dva elementa istih debljina. U tablici prikazane su proračunate efektivne debljine laminiranog stakla sastavljenog od dva elementa iste debljine.

Glass thickness mm	Short duration loads ($\varpi = 0.2$)		Long duration loads ($\varpi = 0.0$)	
	$h_{ef;w}$ mm	$h_{ef;\sigma;j}$ mm	$h_{ef;w}$ mm	$h_{ef;\sigma;j}$ mm
3 + 3	4.42	4.90	3.78	4.24
4 + 4	5.89	6.53	5.04	5.66
5 + 5	7.34	8.17	6.30	7.07
6 + 6	8.84	9.80	7.56	8.49
8 + 8	11.79	13.06	10.08	11.31
10 + 10	14.74	16.33	12.60	14.14

Tablica 5.2.2.2. Efektivne debljine lameliranog stakla sastavljenog od dva elementa jednake debljine

Proračun za svako opterećenje posebno:a) Snijeg:

$$p^* = \left(\frac{2671 \cdot 2000}{4 \cdot (60.34)^2} \right)^2 \cdot \frac{5.6 \cdot 10^{-3}}{70000} = 0.111 - p^* = 1$$

$$k_1 = 0.306$$

Nakon proračunatih vrijednosti, uvrštavamo ih u izraz za maksimalno naprežanje

$$\sigma_{\max} = k_1 \cdot \frac{A}{h^2} \cdot F_d$$

$$\sigma_{\max} = 0.306 \cdot \frac{2671 \cdot 2000}{(60.34)^2} \cdot 5.6 \cdot 10^{-3} = 2.55 \text{ MPa}$$

A uvjet za granično stanje nosivosti

$$\sigma_{\max} \leq f_{g;d} \rightarrow 2.55 \text{ Mpa} < 10.75 \text{ Mpa}$$

b) Pokretno opterećenje:

$$p^* = \left(\frac{2671 \cdot 2000}{4 \cdot (60.34)^2} \right)^2 \cdot \frac{5 \cdot 10^{-3}}{70000} = 0.099 - p^* = 1$$

$$k_1 = 0.306$$

Nakon proračunatih vrijednosti, uvrštavamo ih u izraz za maksimalno naprežanje

$$\sigma_{\max} = k_1 \cdot \frac{A}{h^2} \cdot F_d$$

$$\sigma_{\max} = 0.306 \cdot \frac{2671 \cdot 2000}{(60.34)^2} \cdot 5.0 \cdot 10^{-3} = 2.28 \text{ MPa}$$

A uvjet za granično stanje nosivosti

$$\sigma_{\max} \leq f_{g;d} \rightarrow 2.28 \text{ Mpa} < 20.00 \text{ Mpa}$$

c) Vjetar:

$$p^* = \left(\frac{2671 \cdot 2000}{4 \cdot (60.34)^2} \right)^2 \cdot \frac{1.68 \cdot 10^{-3}}{70000} = 0.033 - p^* = 1$$

$$k_1 = 0.306$$

Nakon proračunatih vrijednosti, uvrštavamo ih u izraz za maksimalno naprežanje

$$\sigma_{\max} = k_1 \cdot \frac{A}{h^2} \cdot F_d$$

$$\sigma_{max} = 0.306 \cdot \frac{2671 \cdot 2000}{(60.34)^2} \cdot 2.4 \cdot 10^{-3} = 1.10 \text{ MPa}$$

A uvjet za granično stanje nosivosti

$$\sigma_{max} \leq f_{g;d} \rightarrow 1.10 \text{ Mpa} < 18.5 \text{ Mpa}$$

Prema izračunu, vidljivo je da je nosivost stakla podnog elementa zadovoljena, međutim, jako malo iskorištena. U slučaju mjerodavnog graničnog stanje, praksa je da se ostvari iskoristivost veća od 75 %.

GRANIČNO STANJE UPORABLJIVOSTI

Prema europskim normama konstrukciju i njene elemente potrebno je kontrolirati ne samo prema graničnim stanjima nosivosti već i na granična stanja uporabljivosti. Mora biti zadovoljen uvjet da je maksimalni progib manji od dopuštenog progiba.

$$w_{max} < w_d$$

Maksimalni progib w_{max} određuje se prema izrazu:

$$w_{max} = k_4 \cdot \frac{A^2}{h^3} \cdot \frac{F_d}{E}$$

Koeficijent k_4 određuje se prema tablici 3.

$\lambda = a/b$	p^*										
	0	1	2	3	5	10	20	50	100	200	300
1,0	0.0461	0.0414	0.0354	0.0310	0.0255	0.0189	0.0137	0.0088	0.0062	0.0044	0.0036
0,9	0.0452	0.0409	0.0351	0.0309	0.0254	0.0188	0.0136	0.0088	0.0062	0.0044	0.0036
0,8	0.0437	0.0399	0.0346	0.0305	0.0253	0.0188	0.0136	0.0087	0.0062	0.0044	0.0036
0,7	0.0404	0.0377	0.0333	0.0297	0.0248	0.0186	0.0136	0.0087	0.0062	0.0044	0.0036
0,6	0.0354	0.0339	0.0309	0.0281	0.0240	0.0183	0.0134	0.0087	0.0062	0.0044	0.0036
0,5	0.0287	0.0281	0.0267	0.0251	0.0222	0.0176	0.0132	0.0086	0.0062	0.0044	0.0036
0,4	0.0208	0.0207	0.0204	0.0199	0.0187	0.0159	0.0125	0.0085	0.0061	0.0044	0.0036
0,3	0.0128	0.0128	0.0127	0.0127	0.0125	0.0119	0.0105	0.0079	0.0059	0.0043	0.0035
0,2	0.0059	0.0059	0.0059	0.0059	0.0059	0.0059	0.0058	0.0055	0.0048	0.0038	0.0033
0,1	0.0015	0.0015	0.0015	0.0015	0.0015	0.0015	0.0015	0.0015	0.0015	0.0015	0.0015

Tablica 5.2.2.3. Tablica za određivanje koeficijenta k_4

Prema normama maksimalni dopušteni progib iznosi $w_d = a(b)/150$. Međutim, mnogi projektanti smatraju da ovakav strogi zahtjev nije racionalan iz razloga što je glavni uzrok progiba panela opterećenje vjetrom koje je prema normama dano za povratni period od 50

godina. Zbog ovih razloga mnogi projektanti uzimaju manje vrijednosti od ovih definiranih normama ($l/100$). Dopušteni progib se izračunava prema:

$$w_d = \frac{a(b)}{100}$$

$a(b)$ – a i b su stranice panela (a mora biti manja dimenzija)

$$w_d = \frac{a(b)}{100} = \frac{2000}{100} = 2 \text{ cm}$$

$$k_4 = 0.0377$$

a) Snijeg

$$w_{\max} = k_4 \cdot \frac{A^2}{h^3} \cdot \frac{F_d}{E}$$

$$w_{\max} = 0.0377 \cdot \frac{(2671 \cdot 2000)^2}{(60.34)^3} \cdot \frac{5.6 \cdot 10^{-3}}{70000} = 0.404 \text{ mm}$$

$$0.404 \text{ mm} < 20 \text{ mm}$$

7. NACRTI

TLOCRT

PRESJEK 1-1

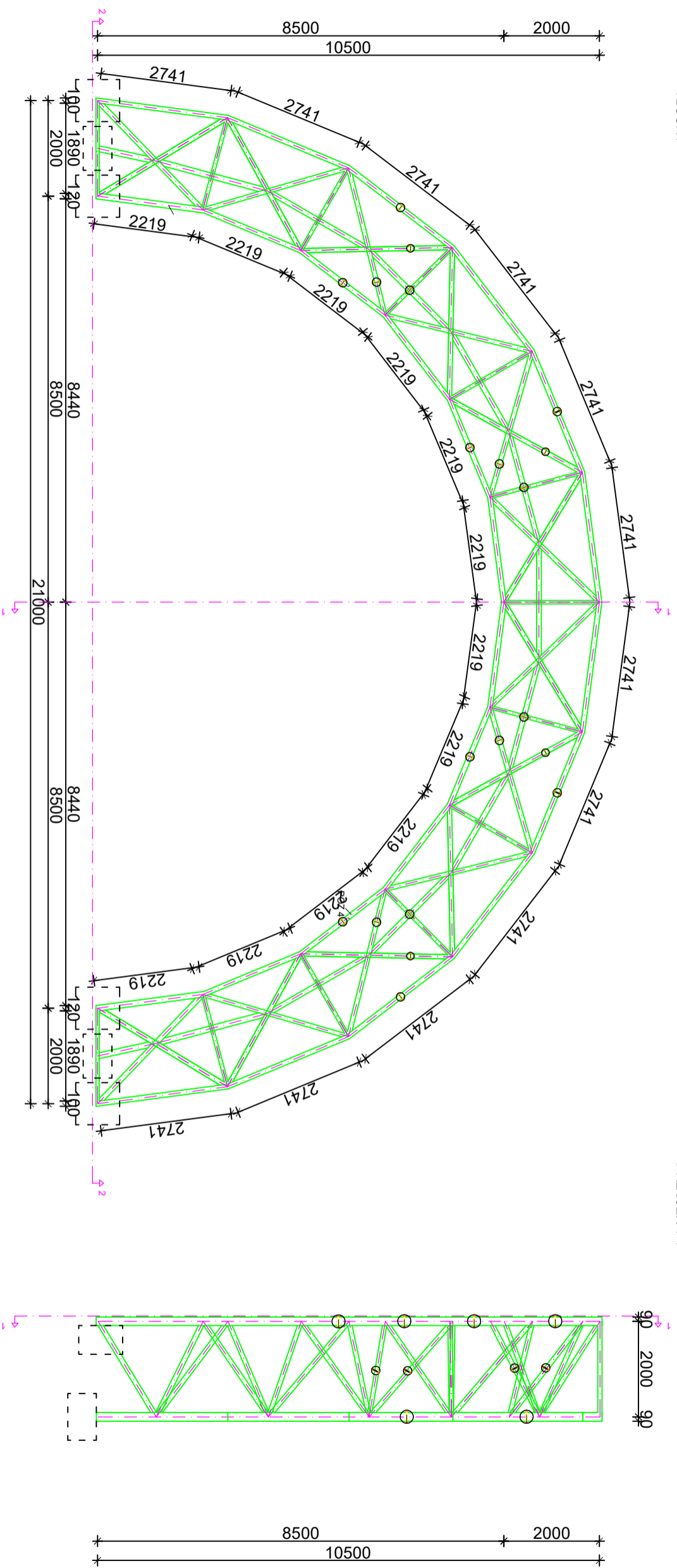

PRESJEK 2-2

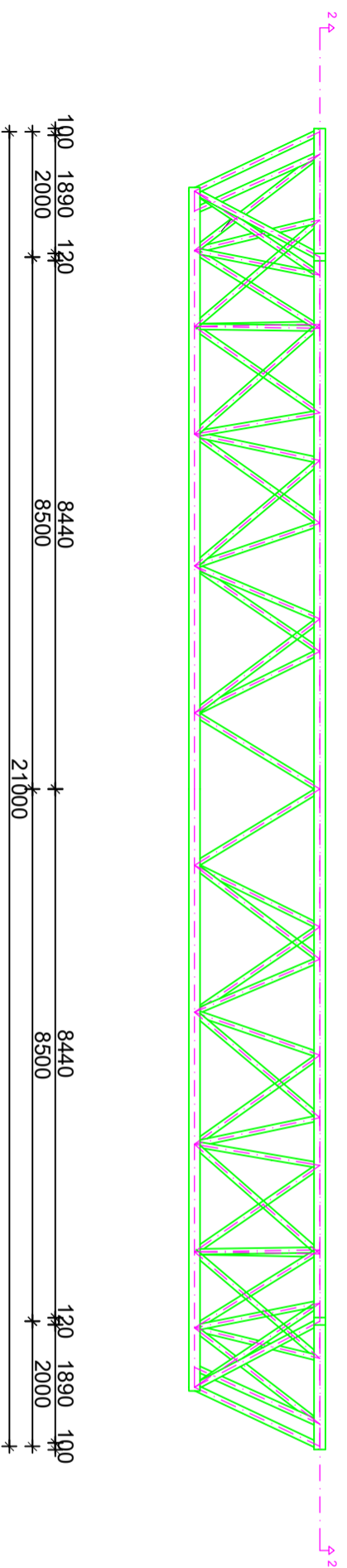

ČELIK S275

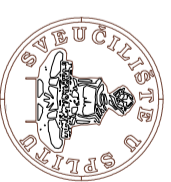

FAKULTET GRADNINARSTVA, ARHITEKTURE I
KATEGORIJA ZA VEŠTAČENJE I
23000 ŠPILJKI, MAJICE RIVAJE 15

DIPLOMSKI RAD

TEMA: TROPOLJASNA ČELIČNA KONSTRUKCIJA

STUDENT: Rubeša Lucija, 824

SAOBRZAJ: POGLJEDI KONSTRUKCIJE

MASŠTO: 1:100

PRILOG: 1

DATUM: 2021.

TLOCRT

POGLEDI ISTOK

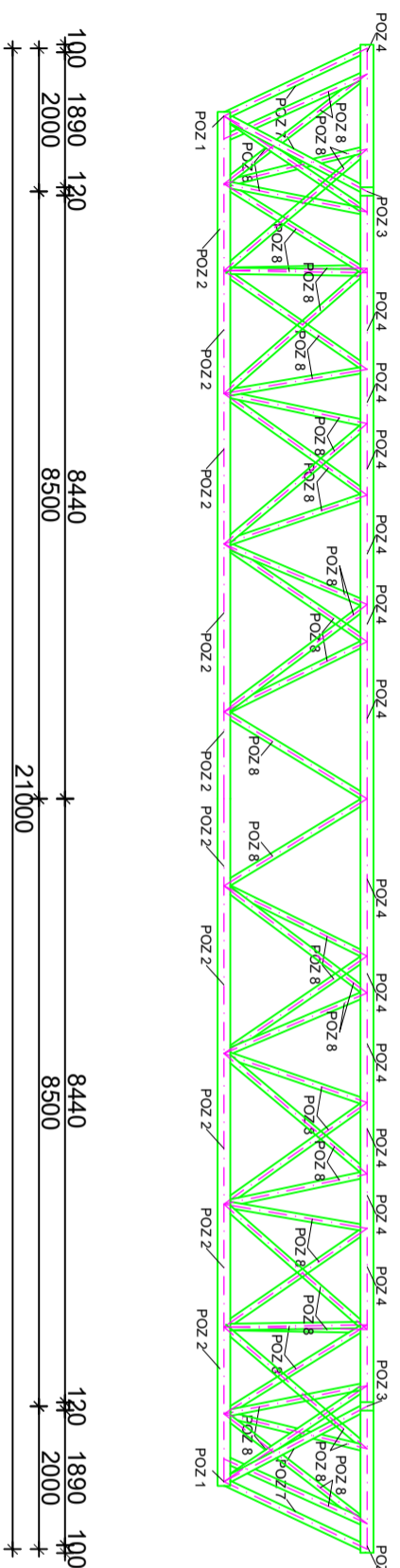
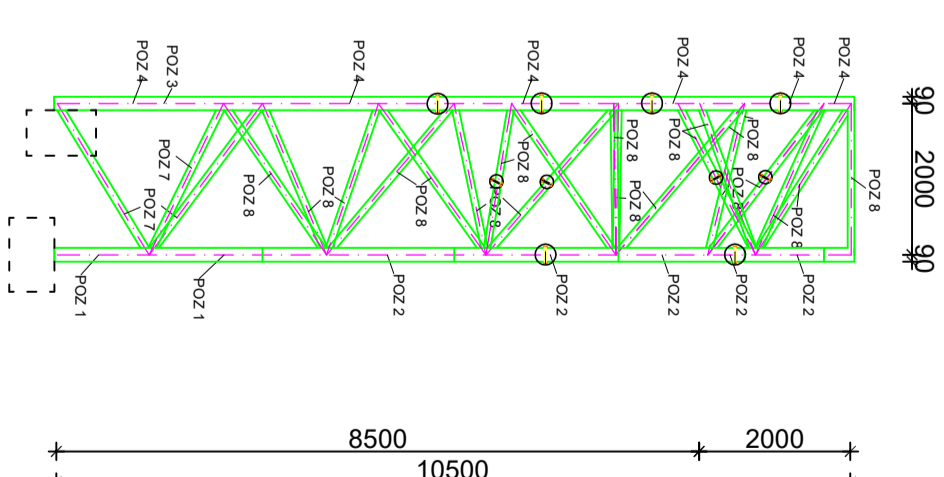
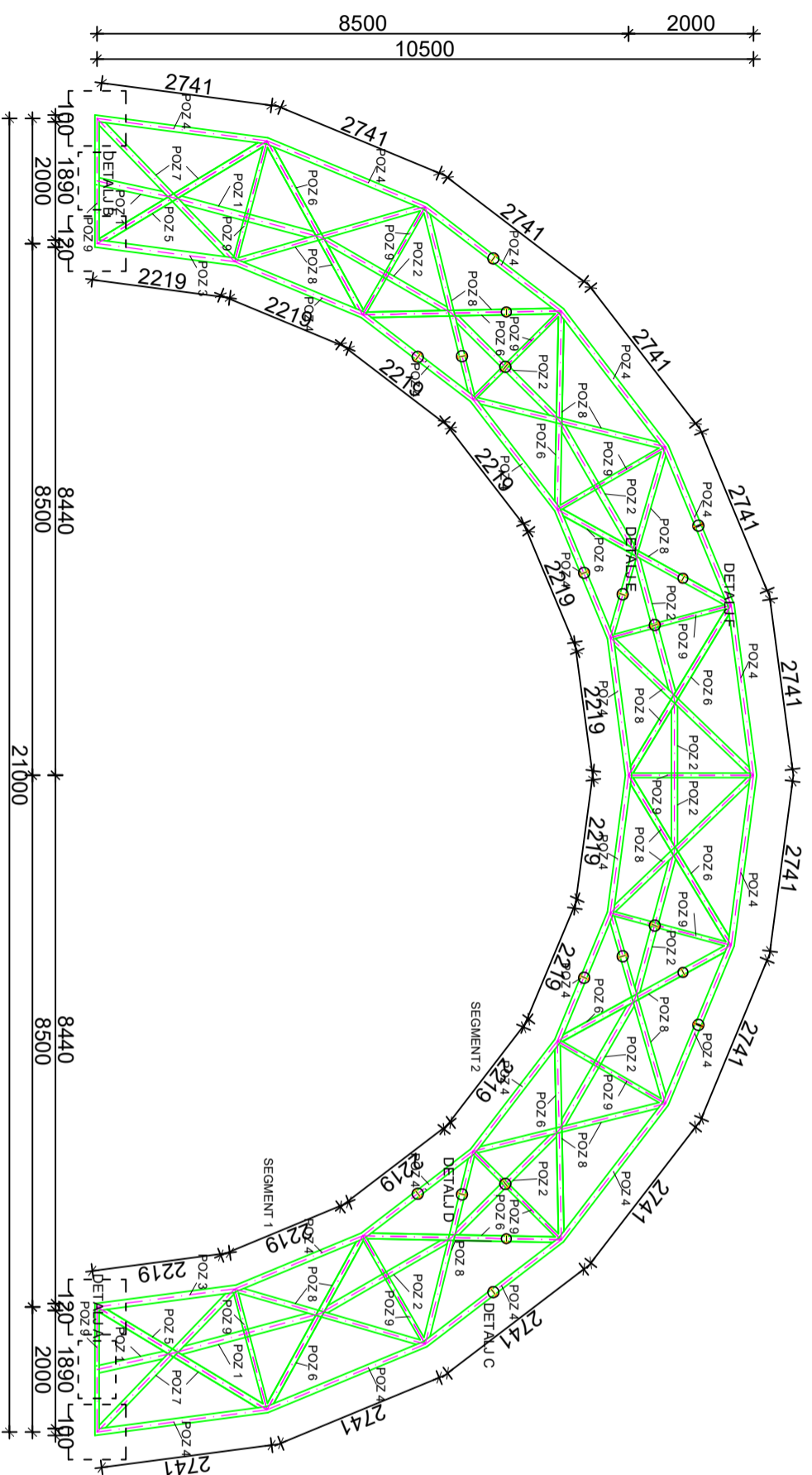

ČELIK S275

DIPLOMSKI RAD

TEMA: TROPOLJASNA ČELIČNA KONSTRUKCIJA

STUDENT: Rubeša Lucia, 824

FAKULTET GRAĐEVINARSTVA, ARHITEKTURE I KATEGORIJA ZAŠTITE I GEOTEHNIČKE KONSTRUKCIJE	2000 SRPSKI NAČIN RAVNANJE 15
SADRŽAJ PLANA POZICIJA KONSTRUKCIJE	MIKROLO 1:100
DATAUM	PRILOG 2

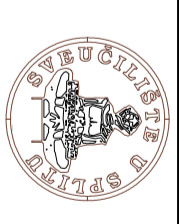

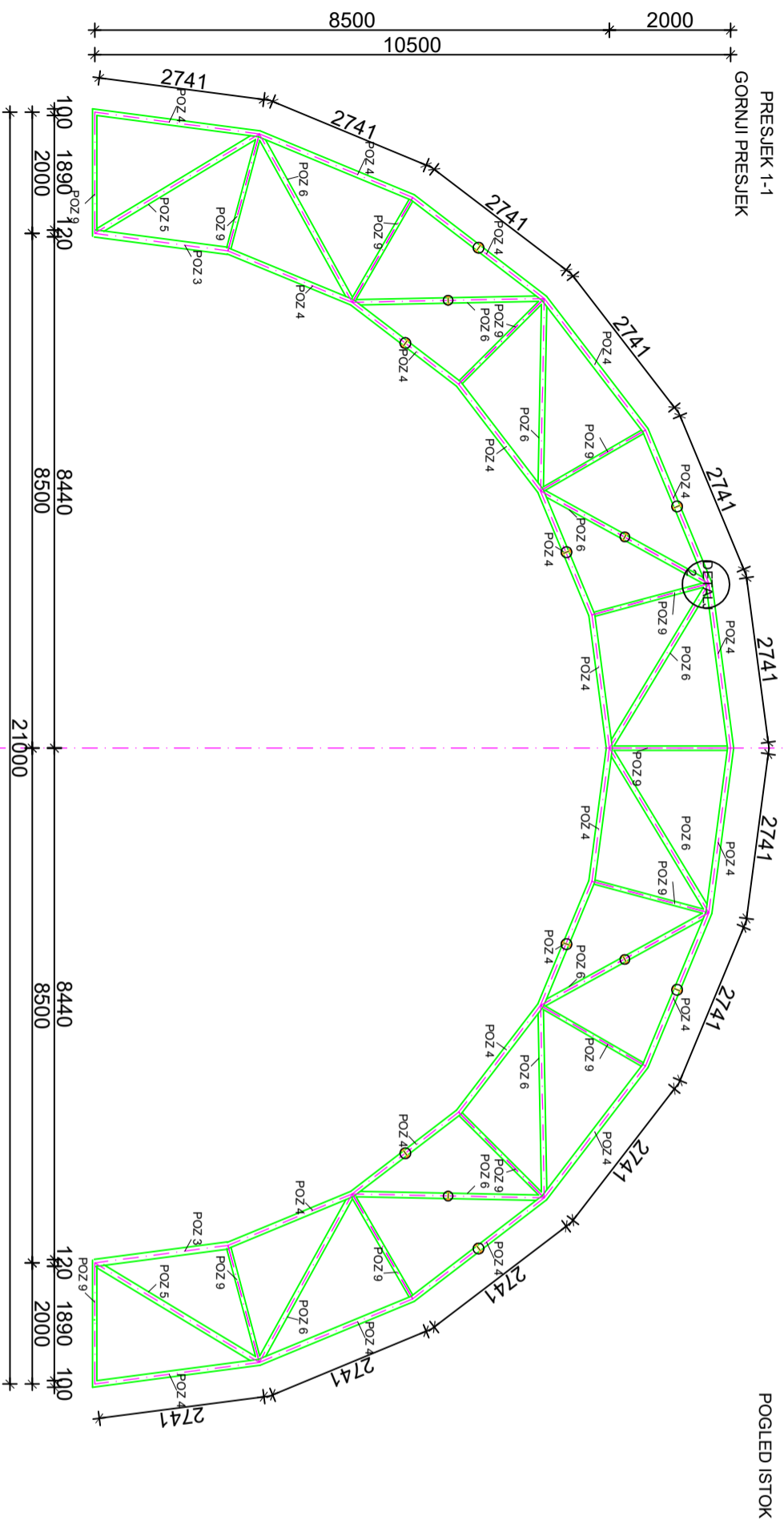

POGLED ISTOK

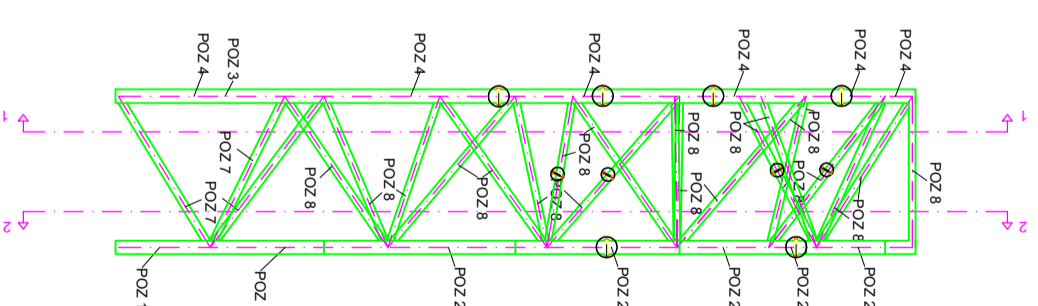

PRESJEK 2-2
DONJI PRESJEK

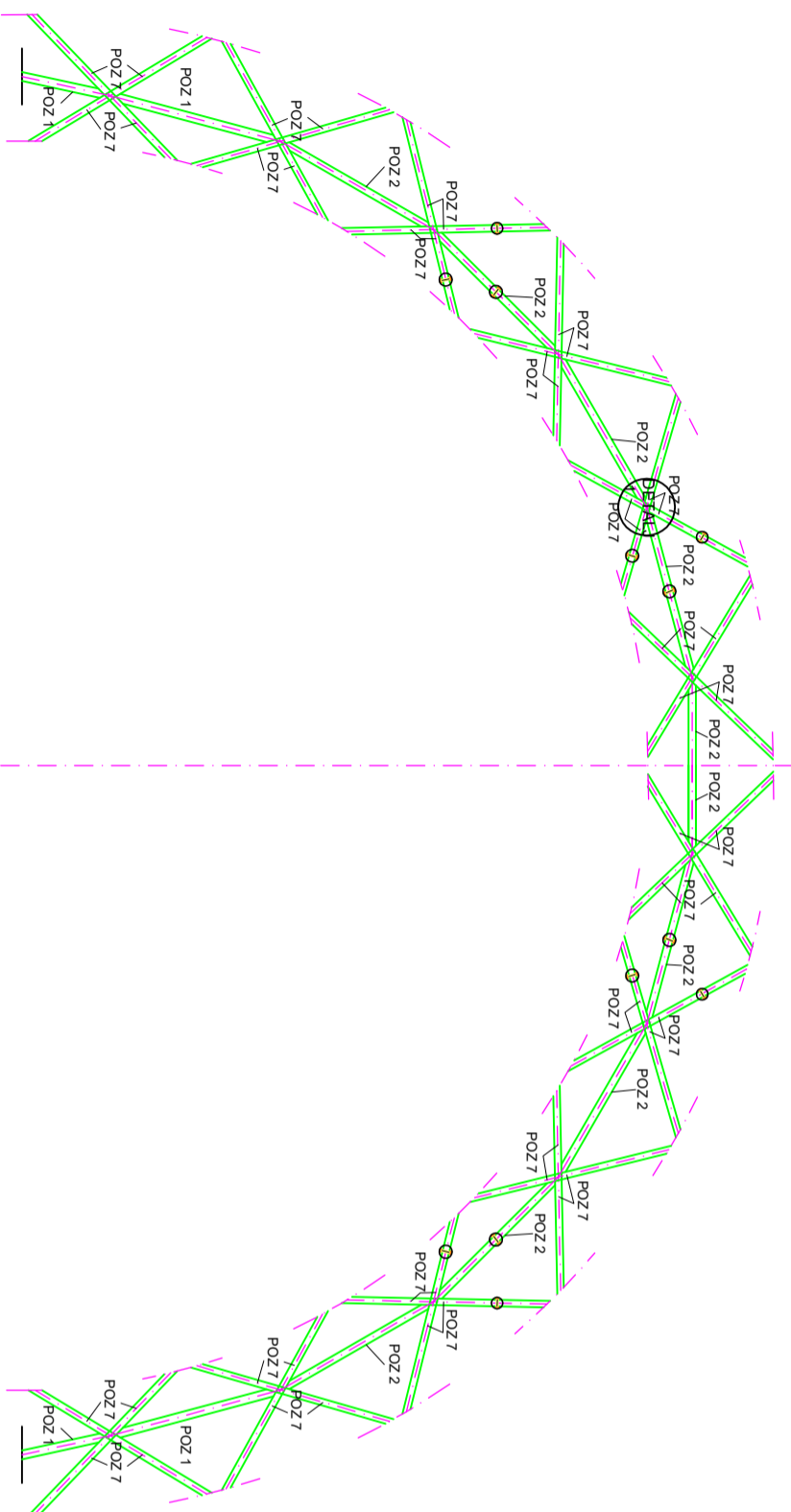

ČELIK S275

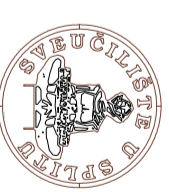

FAKULTET GRADNINARSTVA, ARHITEKTURE I
KATEGORIJA ZA VEŠTAČENJE I KONSTRUKCIJE
28000 ŠPILJKI, MATICE RIVAJE 15

DIPLOMSKI RAD

TEMA: TROPOLJASNA ČELIČNA KONSTRUKCIJA

STUDENT: Rubeša Lucija, 824

SADRŽAJ: PLAN POZICIJA KONSTRUKCIJE MIERILO 1:100
DATUM: 2021. PRILOG 3

PRIKAZ I OPIS POZICIJA

POZICIJA	PROFIL	NAZIV
POZ 1	CFRHS 180x120x8	Donji pojas u prvom i drugom polju
POZ 2	CFRHS 180x100x5	Donji pojas
POZ 3	CFRHS 180x120x8	Gornji pojas - unutarnja strana prvog polja
POZ 4	CFRHS 180x100x5	Gornji pojas
POZ 5	CFRHS 100x100x5	Dijagonale u prvom polju
POZ 6	CFRHS 90x90x5	Dijagonale
POZ 7	CFRHS 100x100x5	Vertikale u prvom polju
POZ 8	CFRHS 90x90x5	Vertikale
POZ 9	CFRHS 70x70x4	Horizontale

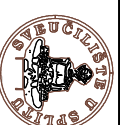

FACULTET ARHITEKTURE I URBANIZACIJE
KATEDRA ZA ARHITEKTURNU KONSTRUKCIJU
20000 ZAGREB, VUKOVIĆEVAC 33

DIPLOMSKI RAD

TEMA: TROKUTASTA OBLONNA KONSTRUKCIJA

STUĐENT:

Rubiša Lucija, 824

SKRZLA PLAN POZICIJA KONSTRUKCIJE Mjerilo: 1:100

DATUM:

2021.

PRILOG: 4

SEGMENT 1

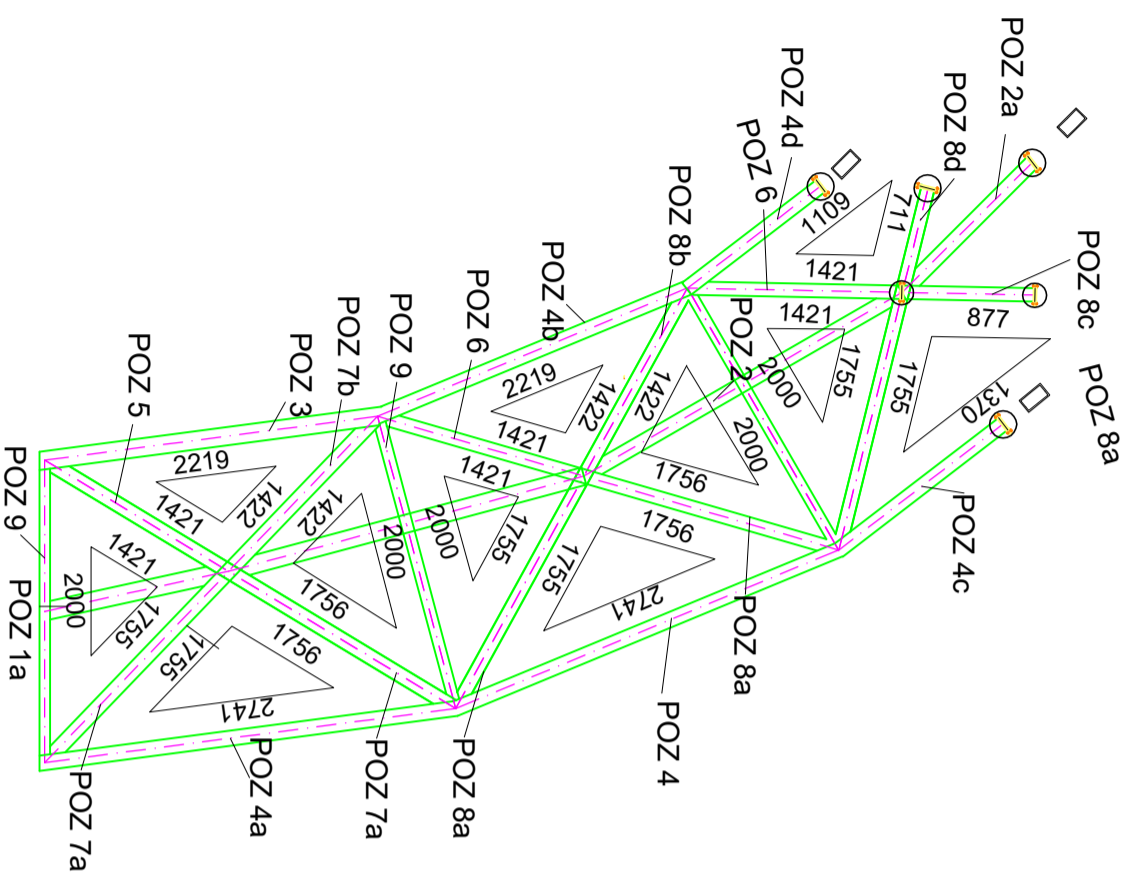

SEGMENT 2

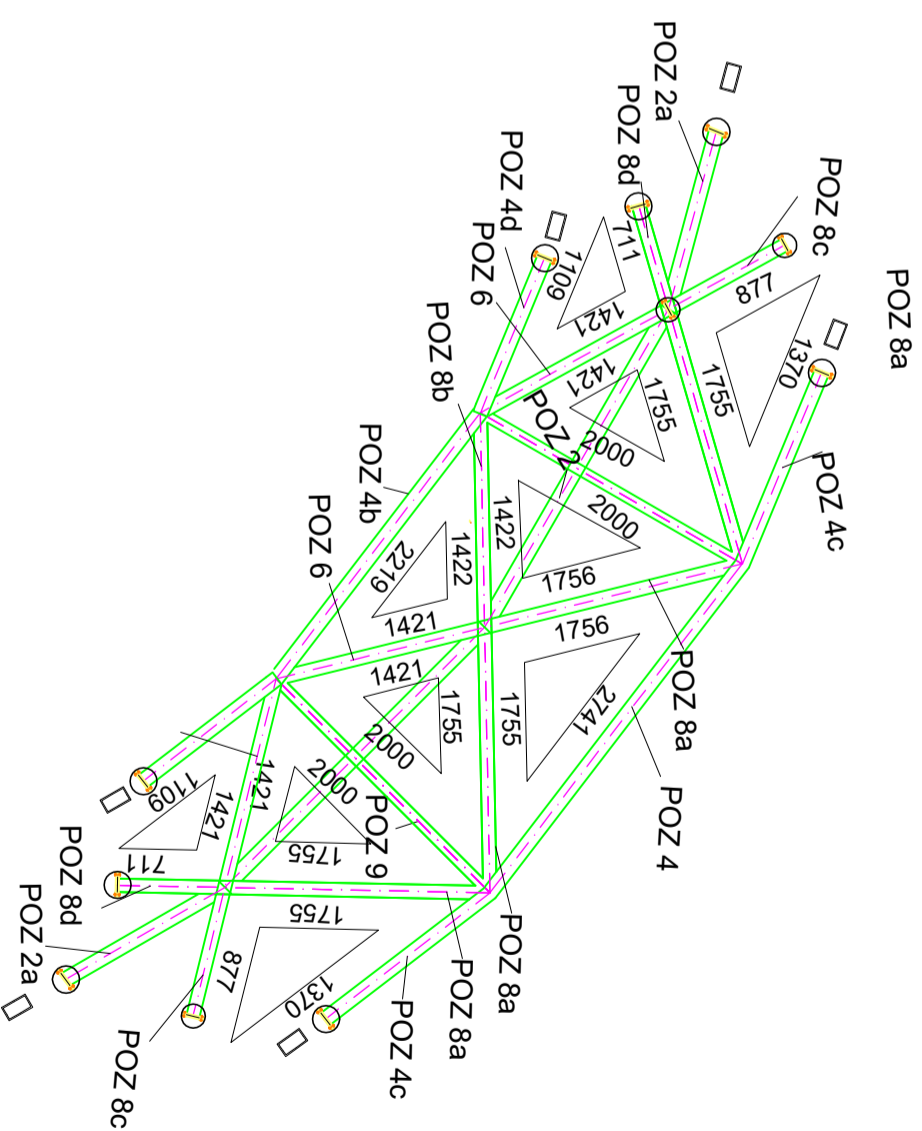

FAKULTET GRAĐEVINARSTVA I ARHITEKTURE
KATEDRA ZA METARHITEKTURNE I ODRŽIVE KONSTRUKCIJE
28000 ŠPILJKOVA ULICA, HRANJEVA, HRVATSKA

DIPLOMSKI RAD

TEMA: TROPOJASNA ČELIČNA KONSTRUKCIJA

STUDENT: Rubeša Lucija, 824

SAOPŠTAJ PLAN POZICIJA ELEMENTA
DATUM: 2021. Mjesečno: 5

Mjesečno: 5

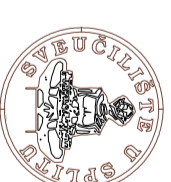
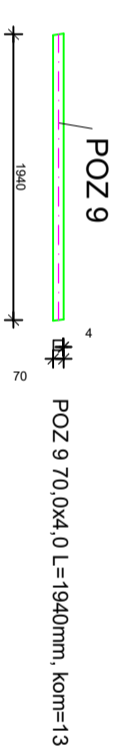
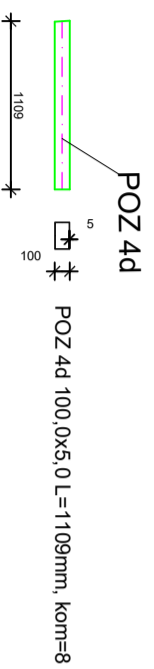
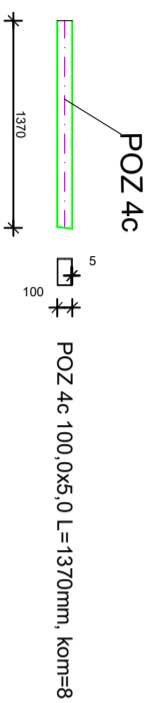
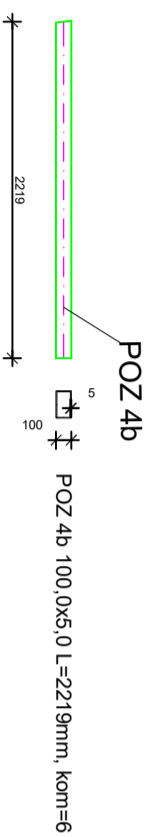
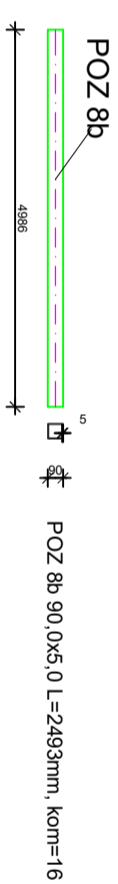
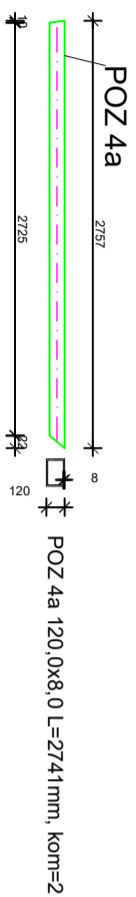
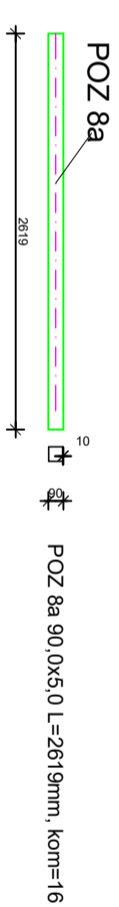
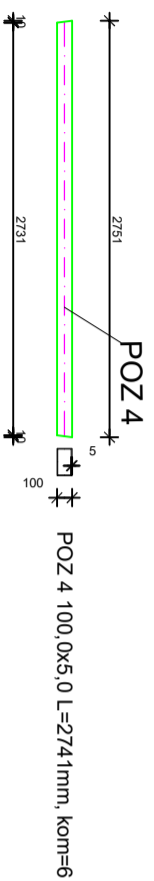
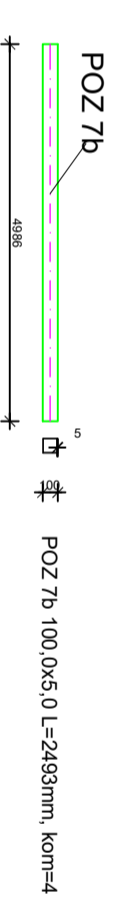
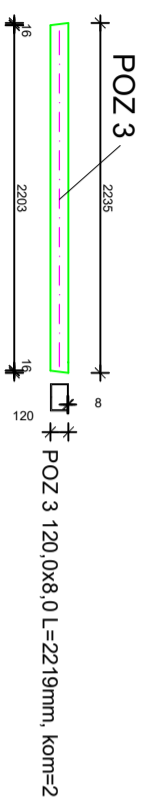
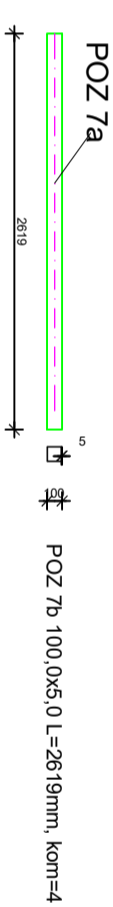
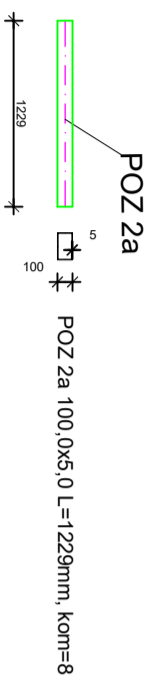
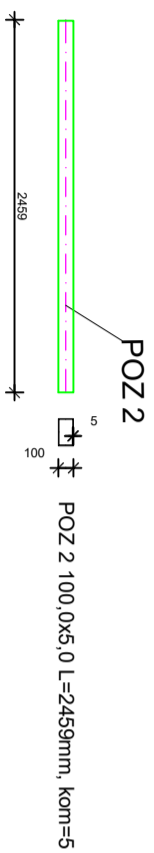
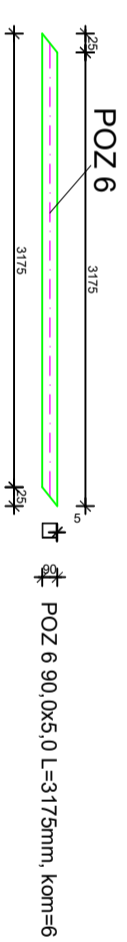
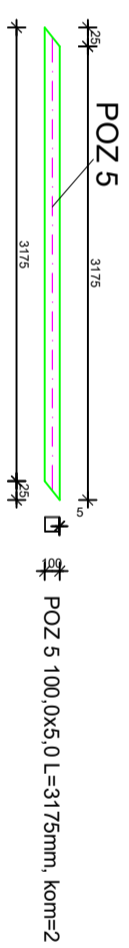
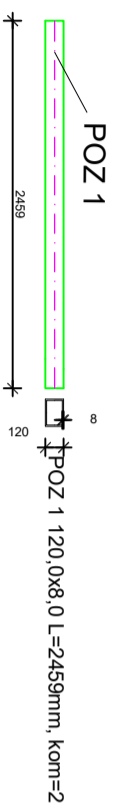

FAKULTET GRADNINARSTVA, ARHITEKTURE I
KATEGORIJA ZAPOSLENI
23000 ŠPILJKI, MATICE RHIVANSKE 15

DIPLOMSKI RAD

TEMA: TROPOJASNA ČELIČNA KONSTRUKCIJA

STUDENT: Rubeša Lucija, 824

SADRŽAJ, RADIONIČKI NACRTI, ELEMENTI I
DATUM: 2021. PRILOG: 6

Presjek 1-1

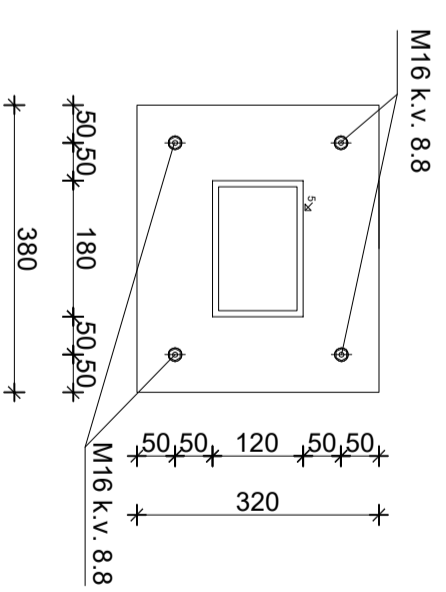
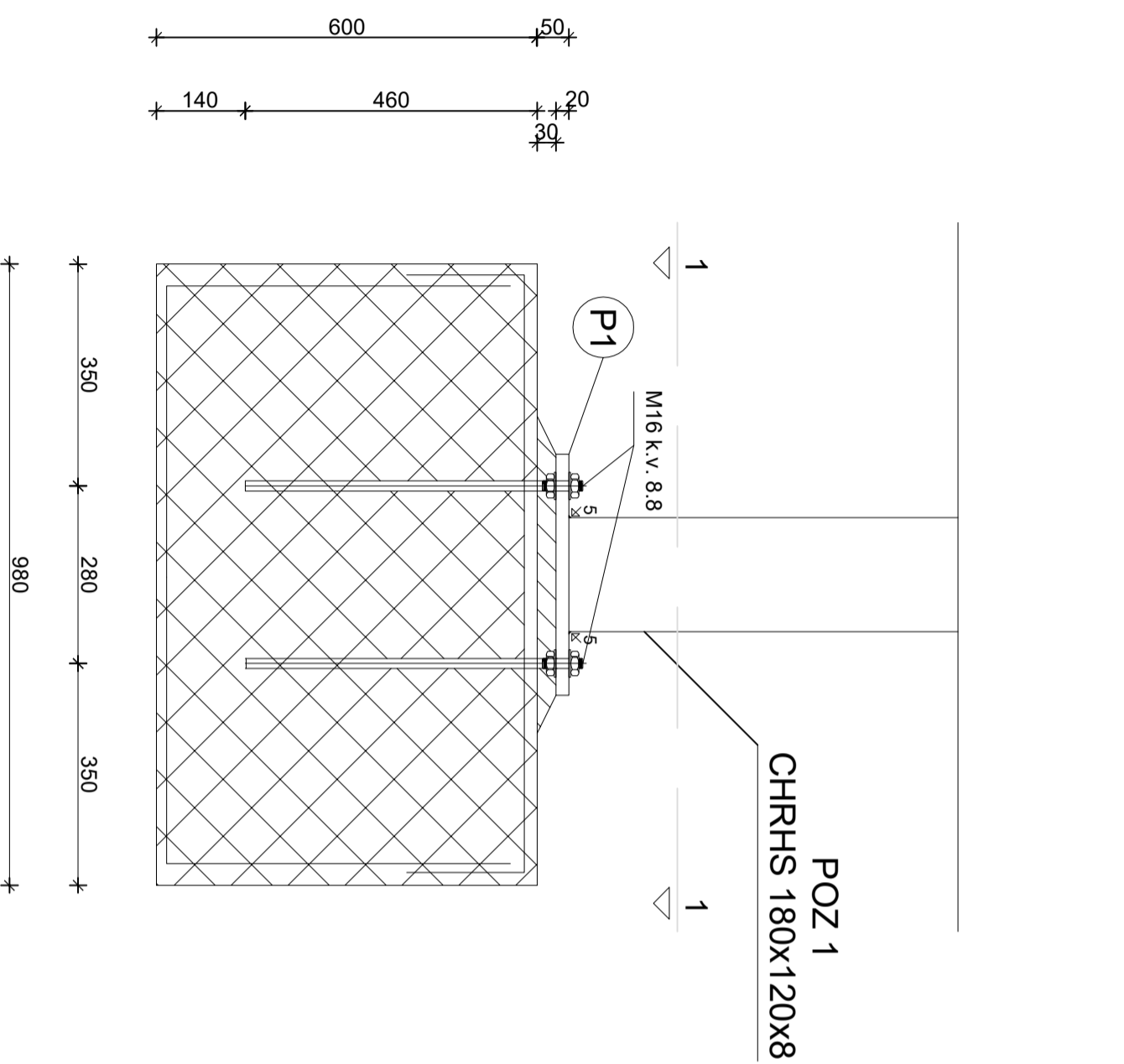

Ⓟ P1 380x320x20 S 275 kom. 1 po pojasu

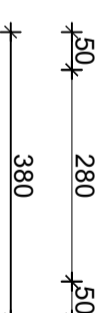
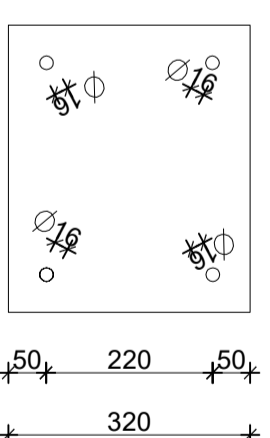
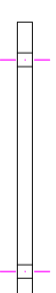

DIPLOMSKI RAD

TEMA:

TROPOJASNA ČELIČNA KONSTRUKCIJA

STUDENT:

Rubeša Lucia, 824

SADRŽAJ

DETALJ "A"

MERILLO 1:10

DATUM

2021.

PRILOG 7

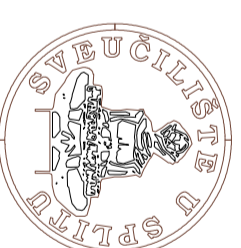

FAKULTET GRAĐEVINARSTVA, ARHITEKTURE I
KATEDRA ZA METALNE I DRVENE KONSTRUKCIJE
21000 SPLIT, MATICE HRVATSKE 15

Presjek 1-1

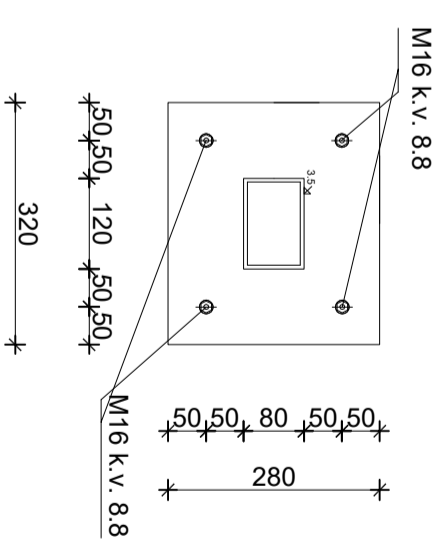

Ⓟ 320x280x20 S 275 kom. 1 po pojasu

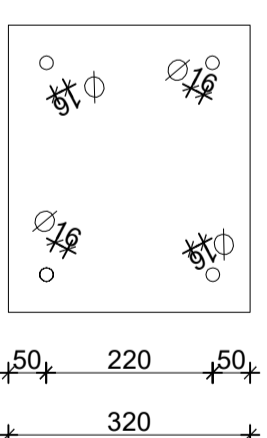
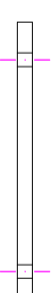

CHRHHS 120x80x5

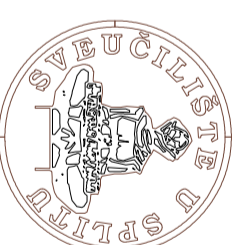
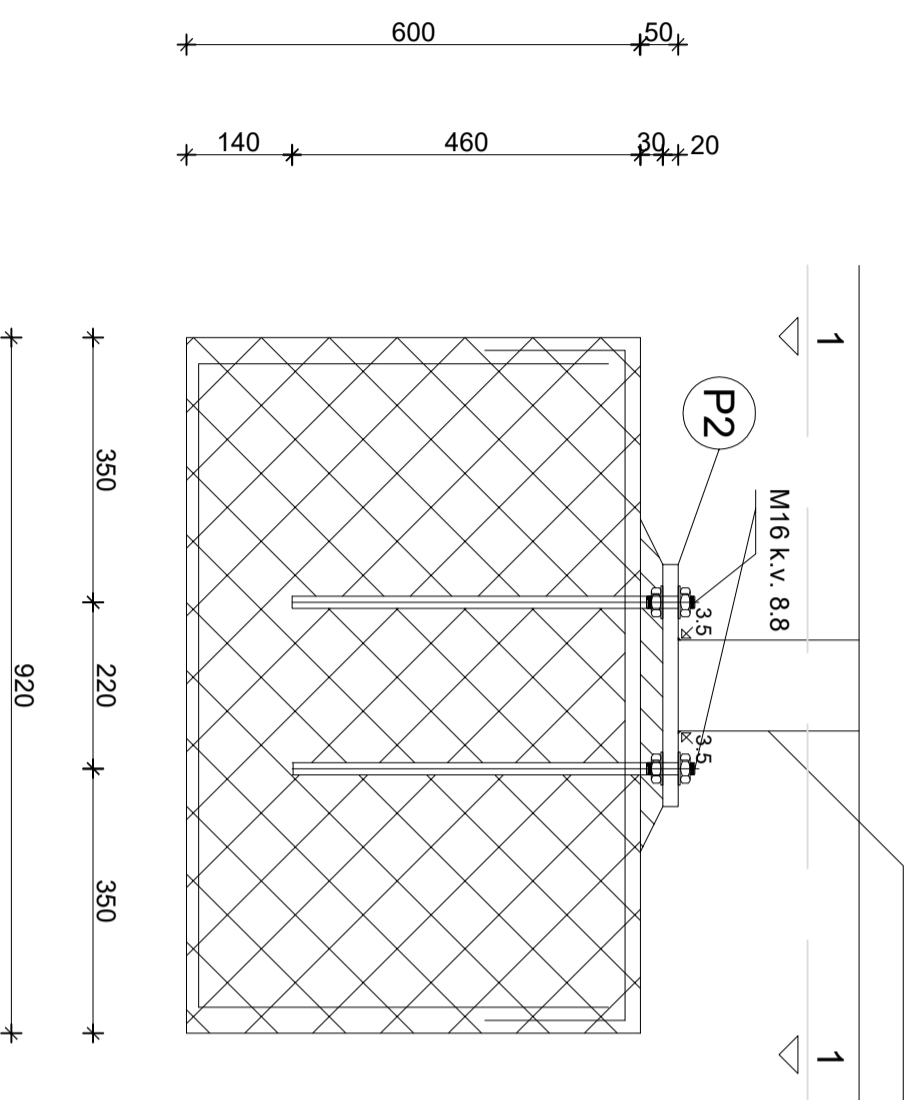

FACULTET GRAĐEVINARSTVA, ARHITEKTURE I
KATEDRA ZA METALNE I DRVENE KONSTRUKCIJE
21000 SPLIT, MATICE HRVATSKE 15

DIPLOMSKI RAD

PREDAŠARANI: TROPOJASNA ČELIČNA KONSTRUKCIJA

STUDENT: Rubeša Lucia, 824

SADRŽAJ	DETALJ "B"	MJERILO	1:10
DATUM	2021.	PRILOG	8

Presjek 2-2

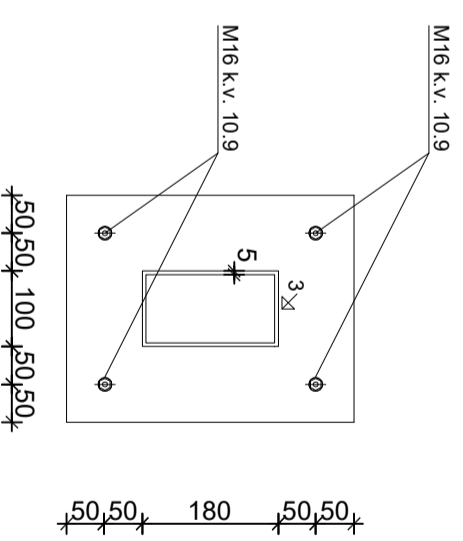
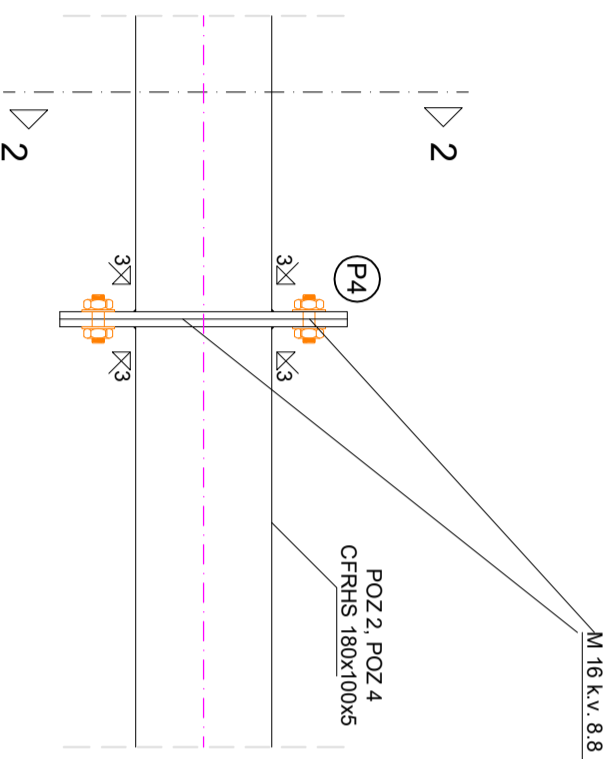

P4 300/380/10 S 275 kom. 2 po spoju

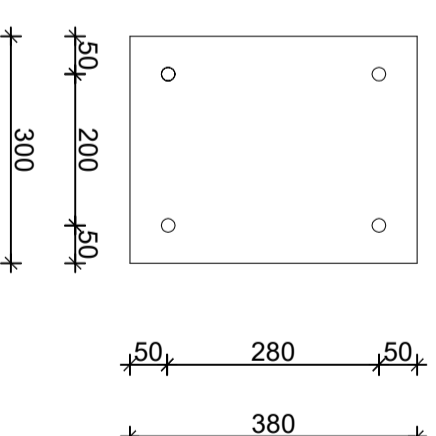
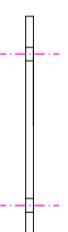

Montažni priključak na gornjem i donjem pojasu u poljima 3,5,8,10

DIPLOMSKI RAD

TEMA:

TROPOJASNA ČELIČNA KONSTRUKCIJA

STUDENT:

Rubeša Lucia, 824

SADRŽAJ

DETALJ "C"

MEŠRLO 1:10

DATUM

2021.

PRILOG 9

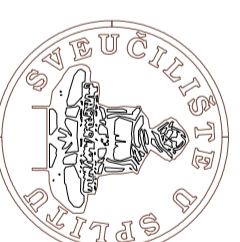

FAKULTET GRAĐEVINARSTVA, ARHITEKTURE I
KATEDRA ZA METALNE I DRVENE KONSTRUKCIJE
GEODEZIJE
21000 SPLIT, MATICE HRVATSKE 15

Presjek 2-2

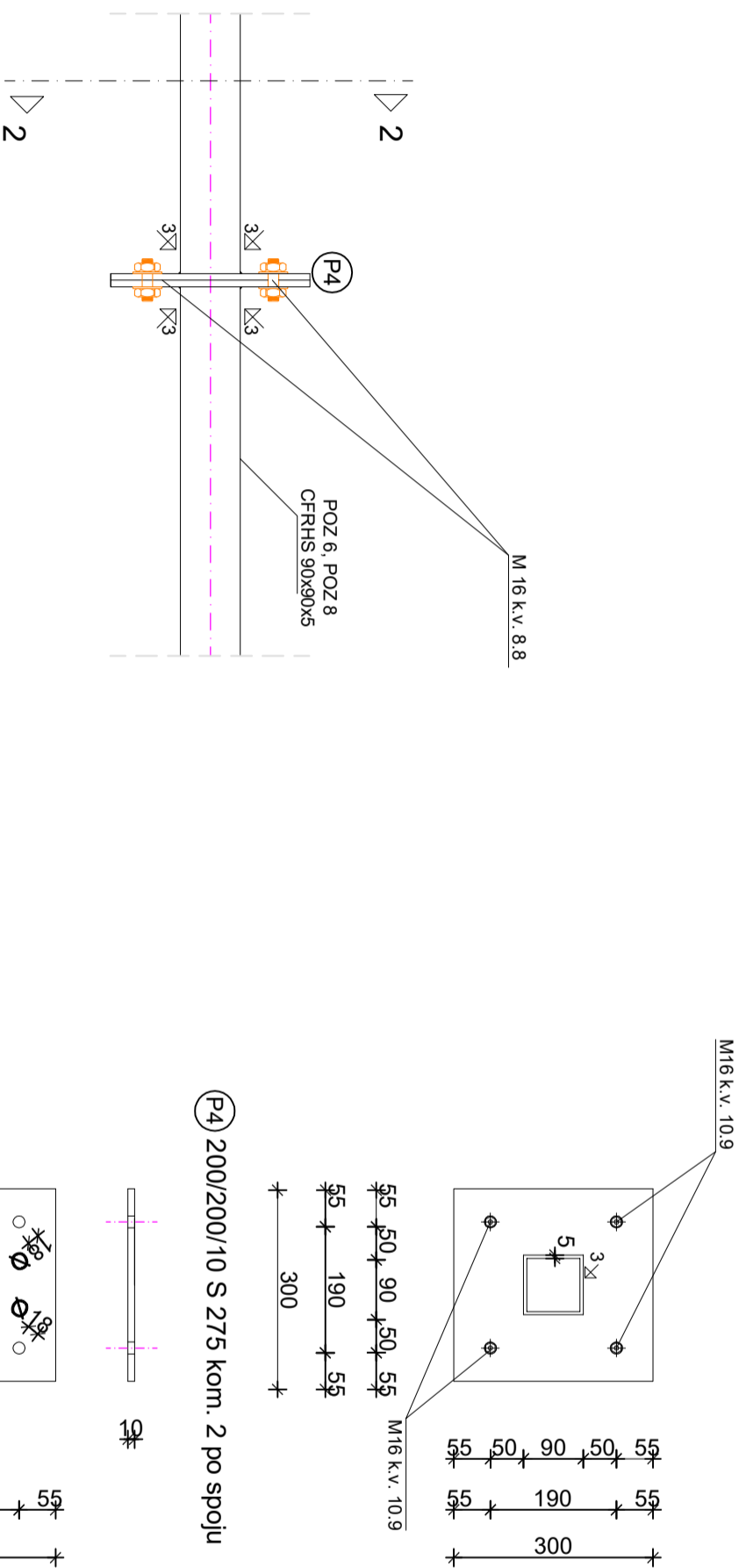

Montažni priključak vertikala i
dijagonala u poljima 3,5,8,10

DIPLOMSKI RAD

TEMA:

TROPOJASNA ČELIČNA KONSTRUKCIJA

STUDENT:

Rubeša Lucia, 824

SAHRŽAJ

DETALJ "D"

MJERILO 1:10

DATUM

2021.

PRILOG 10

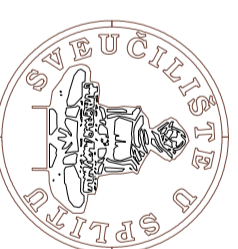

FAKULTET GRAĐEVINARSTVA, ARHITEKTURE I
GEODEZIJE
KATEDRA ZA METALNE I DRVENE KONSTRUKCIJE
21000 SPLIT, MATICE HRVATSKE 15

Presjek 1-1

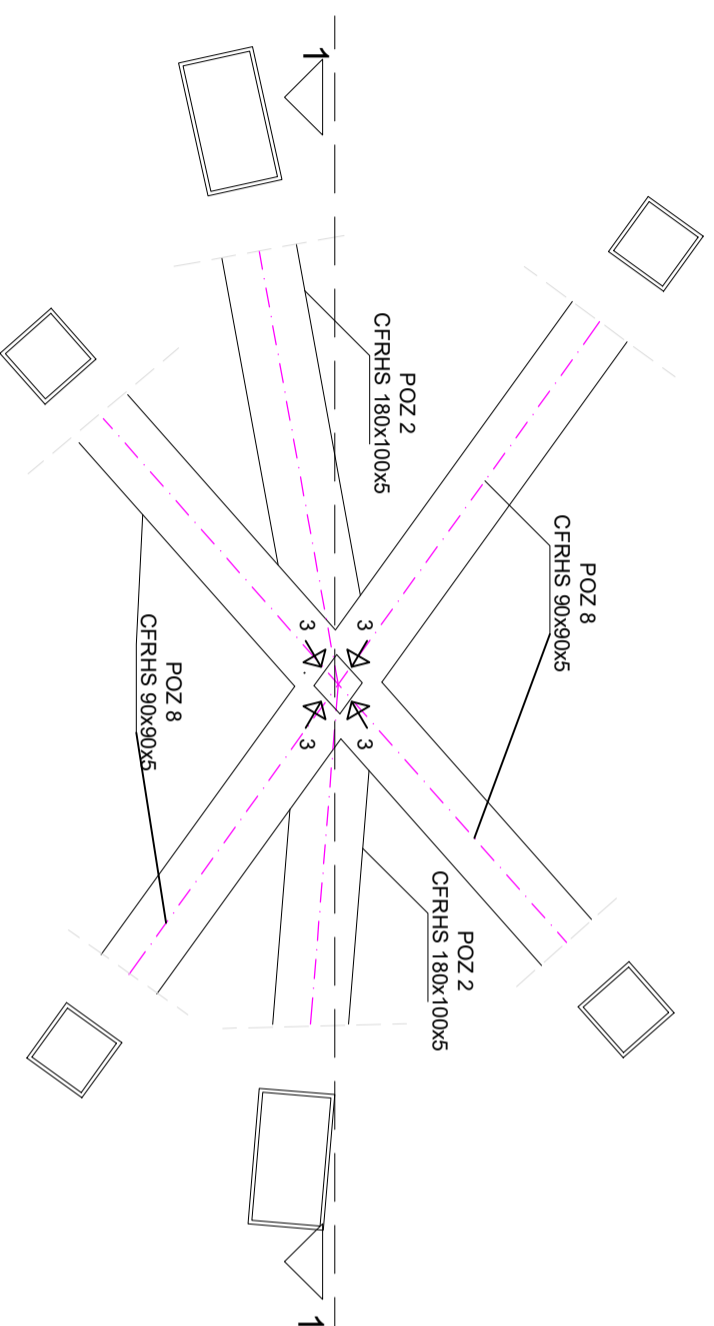
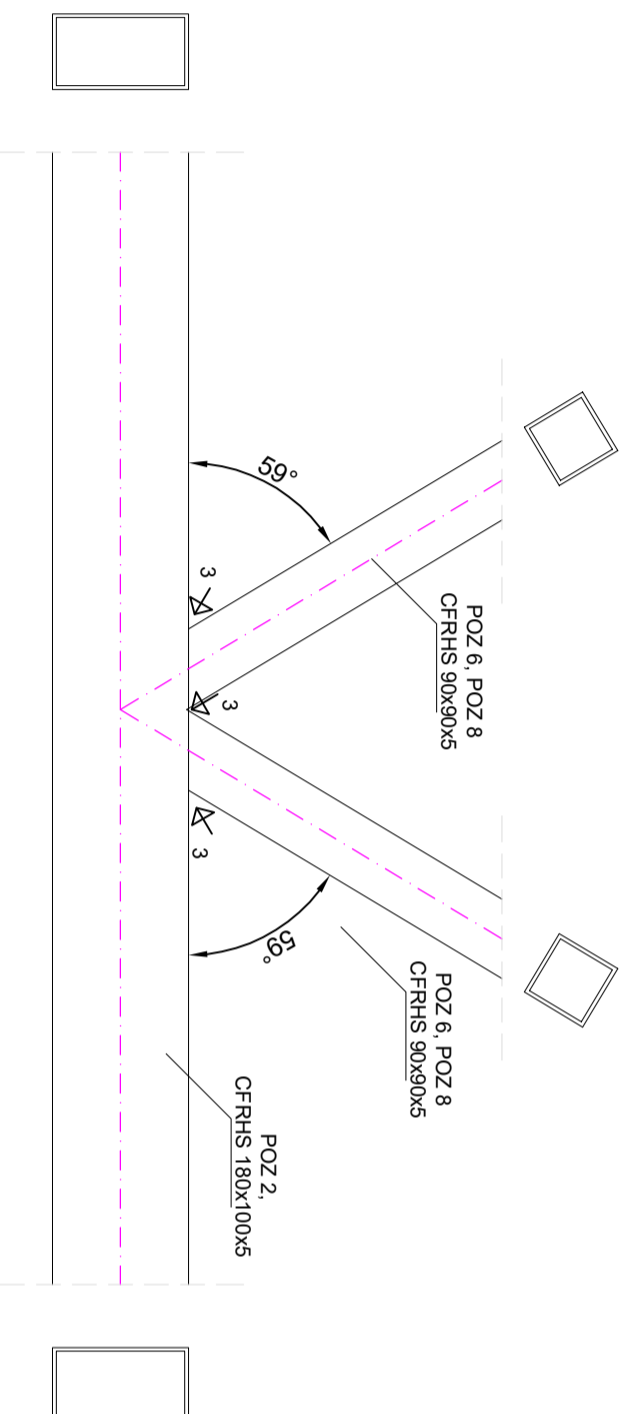

ZAVARENI SPOJ NA DONJEM POJASU REŠETKE

DIPLOMSKI RAD

TEMA:

TROPOJASNA ČELIČNA KONSTRUKCIJA

STUDENT:

Rubeša Lucia, 824

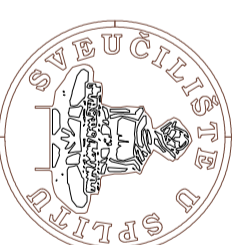

FACULTET GRAĐEVINARSTVA, ARHITEKTURE I
KATEDRA ZA METALNE I DRVENE KONSTRUKCIJE
21000 SPLIT, MATICE HRVATSKE 15

SADRŽAJ

DETALJ "E"

MJERILO 1:10

DATUM

2021.

PRILOG 11

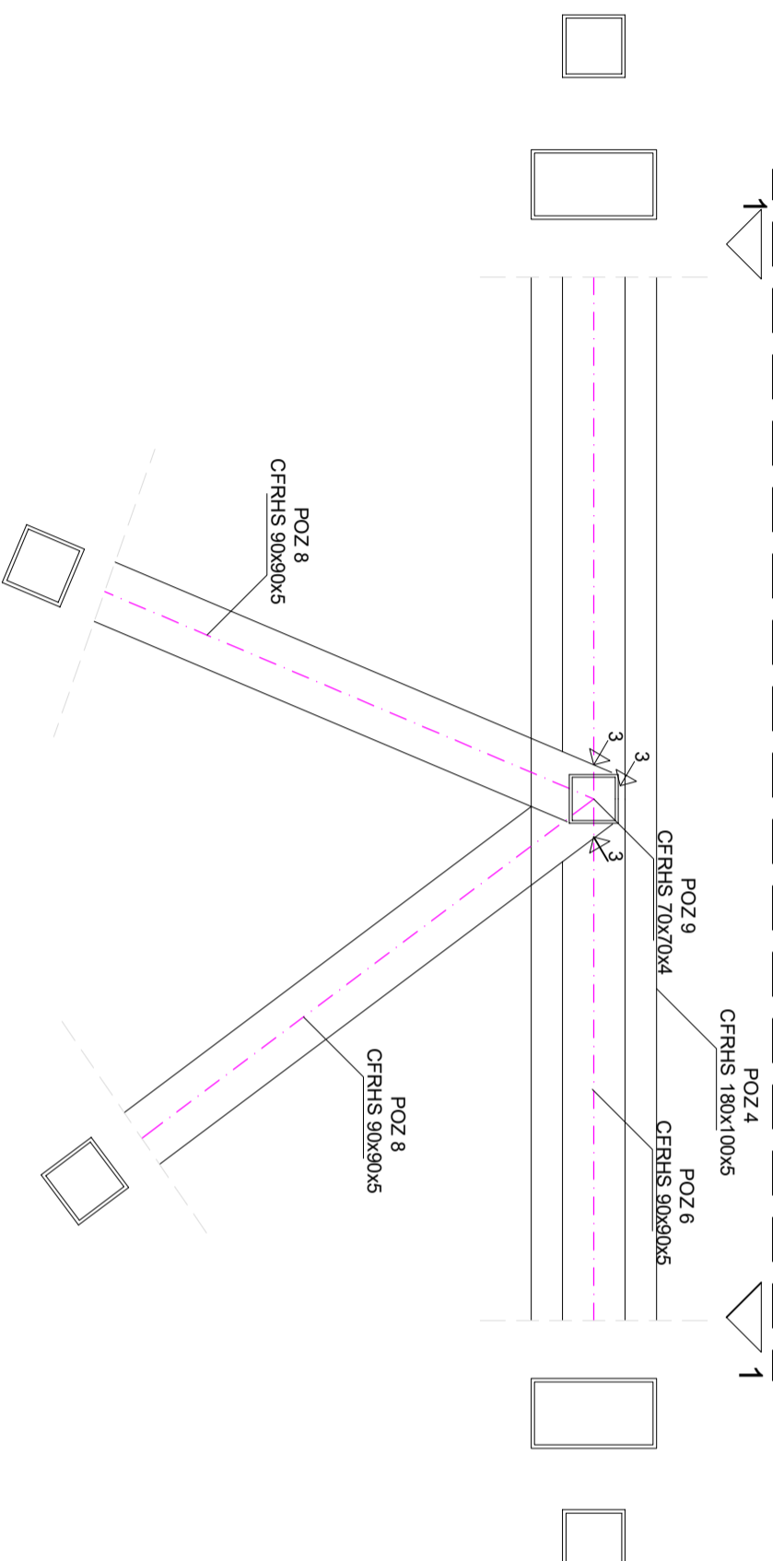

Presjek 1-1

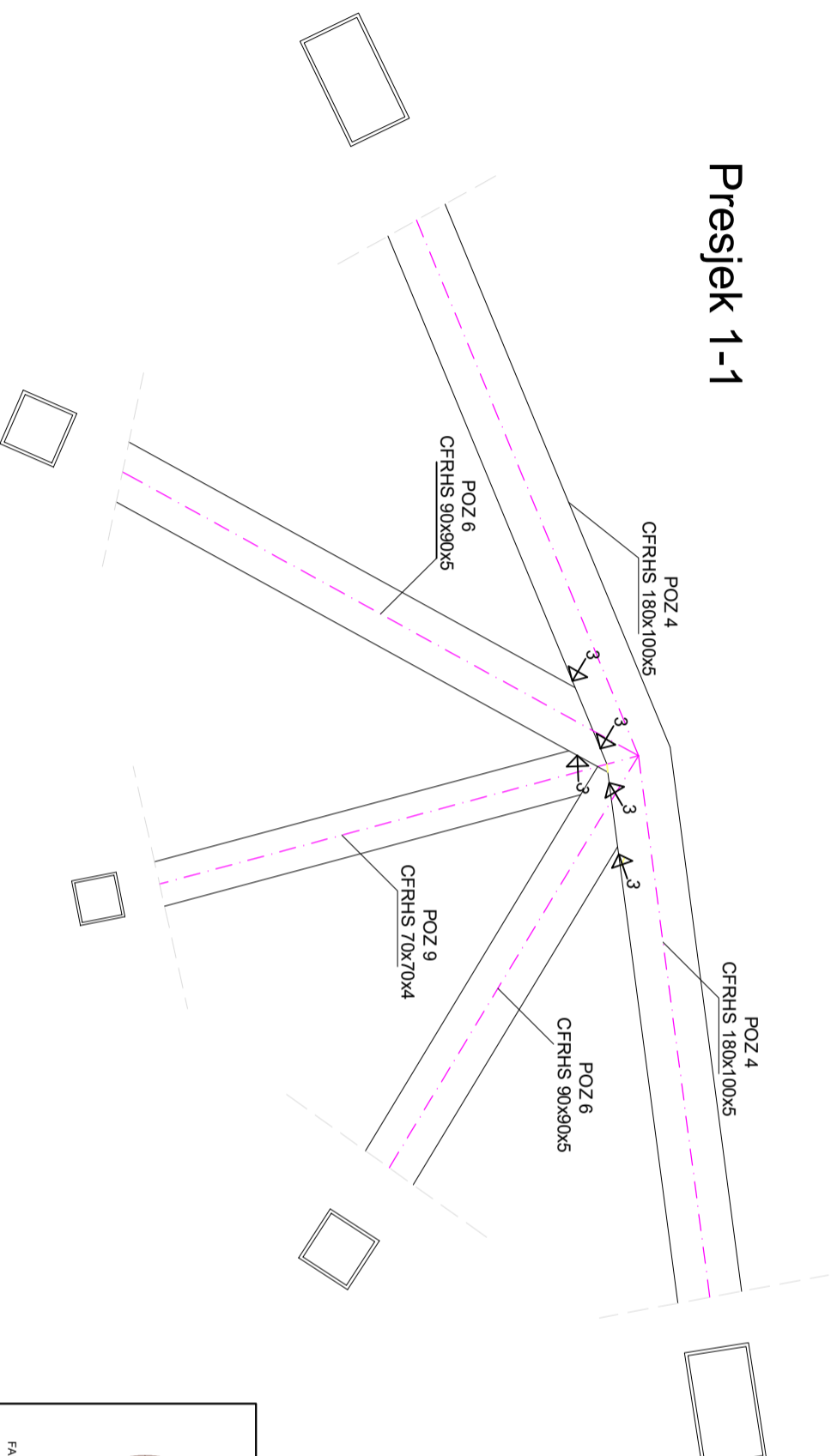

ZAVARENI SPOJ NA
GORNJEM POJASU REŠETKE

DIPLOMSKI RAD

TEMA: TROPOJASNA ČELIČNA KONSTRUKCIJA

STUDENT: Rubeša Lucia, 824

SAHRŽAJ	DETALJ "F"	MJERILO	1:10
DATUM	2021.	PRILOG	12



FAKULTET GRAĐEVINARSTVA, ARHITEKTURE I
KATEDRA ZA METALNE I DRVENE KONSTRUKCIJE
21000 SPLIT, MATICE HRVATSKE 15

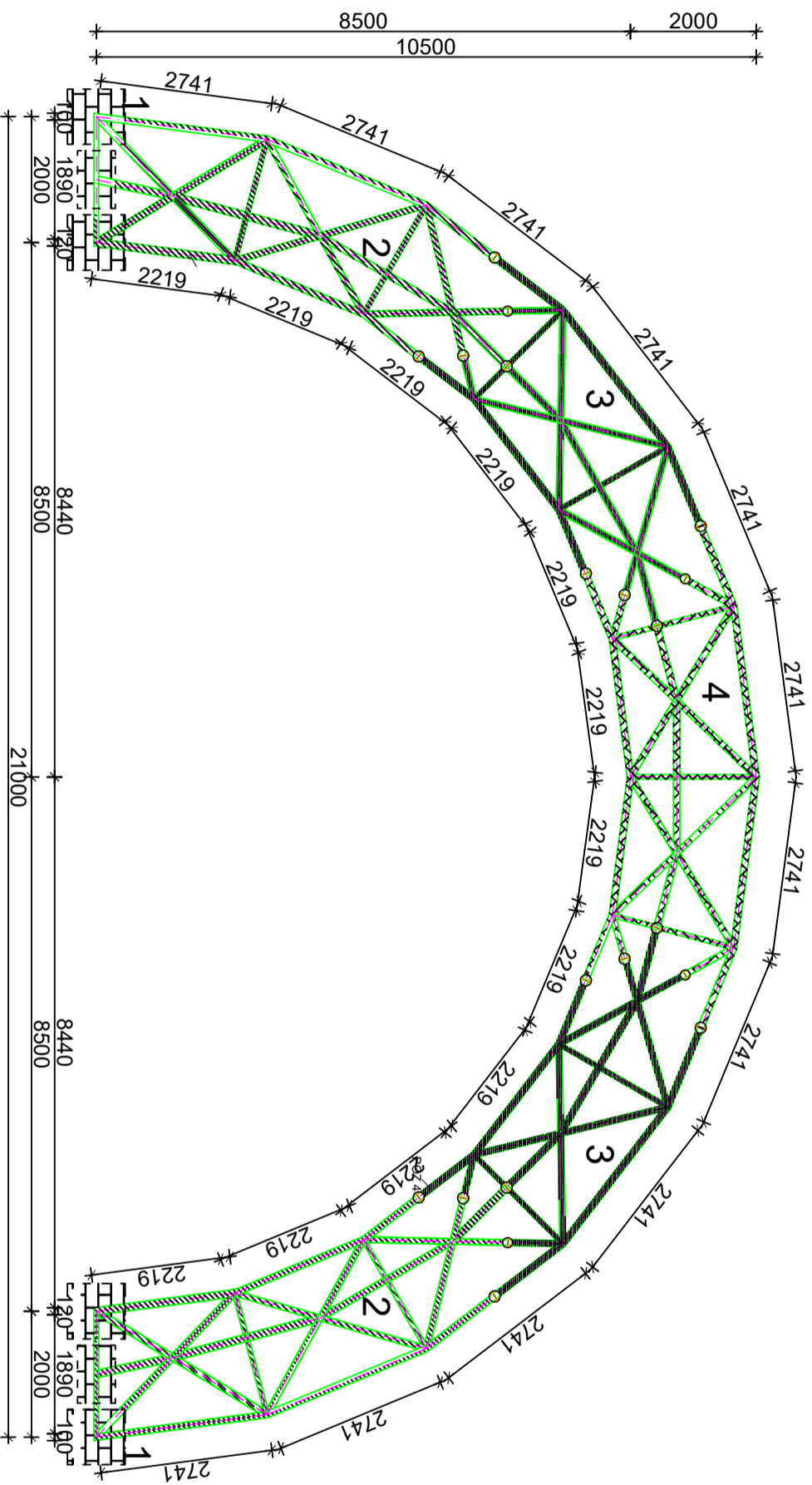

ČELIK S275

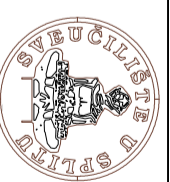

FAKULTET GRADNINARSTVA, ARHITEKTURE I
KATEGORIJA ZA VEŠTAČENJE I KONSTRUKCIJE
23000 SPLIT, MATICE RIVAJEVA 15

DIPLOMSKI RAD

TEMA: TROPOLJASNA ČELIČNA KONSTRUKCIJA

STUDENT: Rubeša Lucija, 824

SAVRZAJU	PLAN MONTAŽE	MAŠTERLO
2021.	2021.	1:100
DATAUM	PRILOG	13

ISKAZ MATERIJALA CIJELOG SUSTAVA

POZICIJA	PROFIL	NAZIV	KOMADA	DULJINA L (m)	JEDINIČNA MASA (kg/m)	UKUPNO (kg)
1	CFRHS 180x120x8	Donji pojas na drugim poljima	2	2,46		292,74
1a	CFRHS 180x120x8	Donji pojas na prvim poljima	2	1,24		147,56
2	CFRHS 180x100x5	Donji pojas	5	2,46		456,33
2a	CFRHS 180x100x5	Donji pojas na mjestima prekida segmenta	8	1,23		365,064
3	CFRHS 180x120x8	Unutarnje strane gornjeg pojasa	2	2,22		264,18
4	CFRHS 180x100x5	Gornji pojas	6	2,74		609,924
4a	CFRHS 180x120x8	Gornji pojas s vanjske strane	2	2,74		326,06
4b	CFRHS 180x100x5	Gornji pojas s unutarnje strane	6	2,74		609,924
4c	CFRHS 180x100x5	Gornji pojas s vanjske strane na prekidima segmenata	8	1,38		409,584
4d	CFRHS 180x100x5	Gornji pojas s unutarnje strane na prekidima segmenata	8	1,11		329,448
5	CFRHS 100x100x5	Dijagonale u prvim poljima	2	3,18		160,272
6	CFRHS 90x90x5	Dijagonale u ostalim poljima	6	3,18		427,392
6a	CFRHS 90x90x5	Dijagonale na mjestima prekida segmenata	6	1,59		213,696
7a	CFRHS 100x100x5	Vertikale u prvim poljima s vanjske strane	4	2,62		264,096
7b	CFRHS 100x100x5	Vertikale u prvim poljima s unutarnje strane	4	2,49		250,992
8a	CFRHS 90x90x5	Vertikale na ostalim poljima s vanjske strane	16	2,62		939,008
8b	CFRHS 90x90x5	Vertikale na ostalim poljima s unutarnje strane	16	2,49		892,416
8c	CFRHS 90x90x5	Vertikale na mjestima prekida segmenata s vanjske strane	8	1,31		234,752
8d	CFRHS 90x90x5	Vertikale na mjestima prekida segmenata s unutarnje strane	8	1,25		224
9	CFRHS 70x70x4	Horizontalne	13	1,94		351,75595
					SUMA	7769,19395
					Dodatak na spojne elemente 10%	8546,11335 kg

IZVORI

- (1) file:///C:/Users/Lucia/OneDrive/Radna%20povr%C5%A1ina/HRN_EN_1991-1-4_2012.pdf
- (2) <https://www.phd.eng.br/wp-content/uploads/2015/12/en.1990.2002.pdf>