

Projekt nosive armiranobetonske konstrukcije poslovnog objekta

Biloš, Ante

Undergraduate thesis / Završni rad

2017

Degree Grantor / Ustanova koja je dodijelila akademski / stručni stupanj:

University of Split, Faculty of Civil Engineering, Architecture and Geodesy / Sveučilište u Splitu, Fakultet građevinarstva, arhitekture i geodezije

Permanent link / Trajna poveznica: <https://um.nsk.hr/um:nbn:hr:123:152782>

Rights / Prava: [In copyright](#)/[Zaštićeno autorskim pravom.](#)

Download date / Datum preuzimanja: **2025-02-18**



Repository / Repozitorij:

[FCEAG Repository - Repository of the Faculty of Civil Engineering, Architecture and Geodesy, University of Split](#)



UNIVERSITY OF SPLIT



DIGITALNI AKADEMSKI ARHIVI I REPOZITORIJI

SVEUČILIŠTE U SPLITU
FAKULTET GRAĐEVINARSTVA, ARHITEKTURE I GEODEZIJE

ZAVRŠNI RAD

Ante Biloš

Split, 2017

SVEUČILIŠTE U SPLITU
FAKULTET GRAĐEVINARSTVA, ARHITEKTURE I GEODEZIJE

**Projekt nosive armiranobetonske konstrukcije
poslovnog objekta**

Završni rad

Split, 2017.

SVEUČILIŠTE U SPLITU

FAKULTET GRAĐEVINARSTVA, ARHITEKTURE I GEODEZIJE

Split, Matice hrvatske 15

STUDIJ: **STRUČNI STUDIJ GRAĐEVINARSTVA**

KANDIDAT: Ante Biloš

BROJ INDEKSA: 1564

KATEDRA: **Katedra za betonske konstrukcije i mostove**

PREDMET: Betonske konstrukcije 2

ZADATAK ZA ZAVRŠNI RAD

Tema: Projekt nosive armiranobetonske konstrukcije poslovnog objekta

Opis zadatka:

Zadana je shema nosive konstrukcije armiranobetonskog objekta poslovne namjene, sa svim potrebnim dimenzijama (prilog zadatku). Također su zadana djelovanja na konstrukciju. Potrebno je proračunati nosivu konstrukciju, te za neke elemente nacrtati planove oplata i armature. Statički proračun i armaturne planove izraditi sukladno propisima i pravilima struke.

U Splitu, 28.10.2016.

Voditelji Završnog rada:

mr.sc. Vladica Herak Marović, v.pred.

dr.sc. Nikola Grgić

PRILOG:

Na priloženim skicama dana je shema nosive armiranobetonske konstrukcije objekta. U tablici su zadane sve potrebne dimenzije i djelovanja na konstrukciju.

Oznaka	Veličina	Jedinica	Opis
L_1	6,9	(m)	„raster“ u uzdužnom smjeru
L_2	6,2	(m)	„raster“ u poprečnom smjeru
H	3,0	(m)	visina etaža
q	3,5	(kN/m ²)	uporabno opterećenje
Z_v	III		zona vjetrova
a_g		(m/s ²)	proračunsko ubrzanje tla
S	B 500 B		armatura
C	C 40/50		klasa betona

(i) Presjek

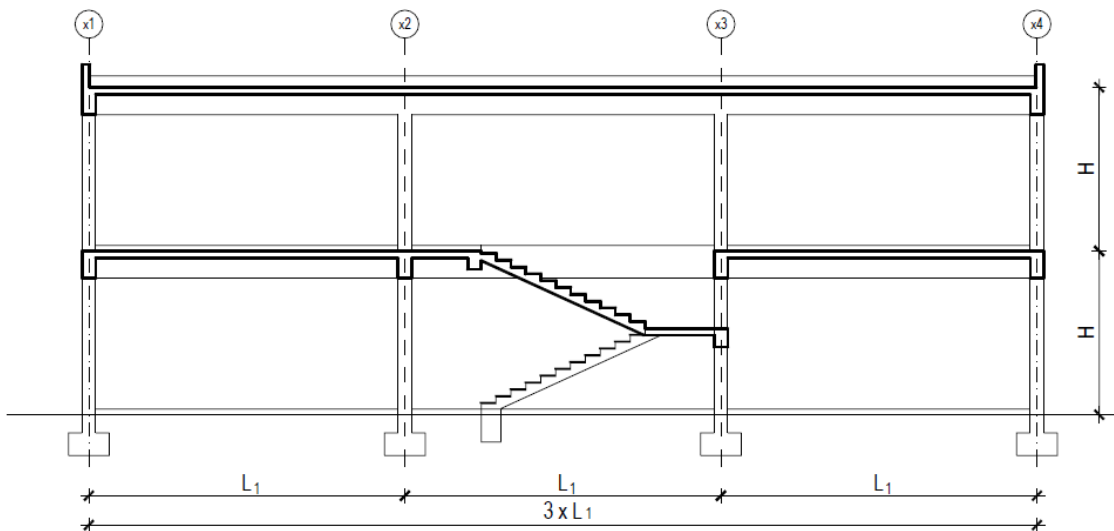

(ii) Međuetaze

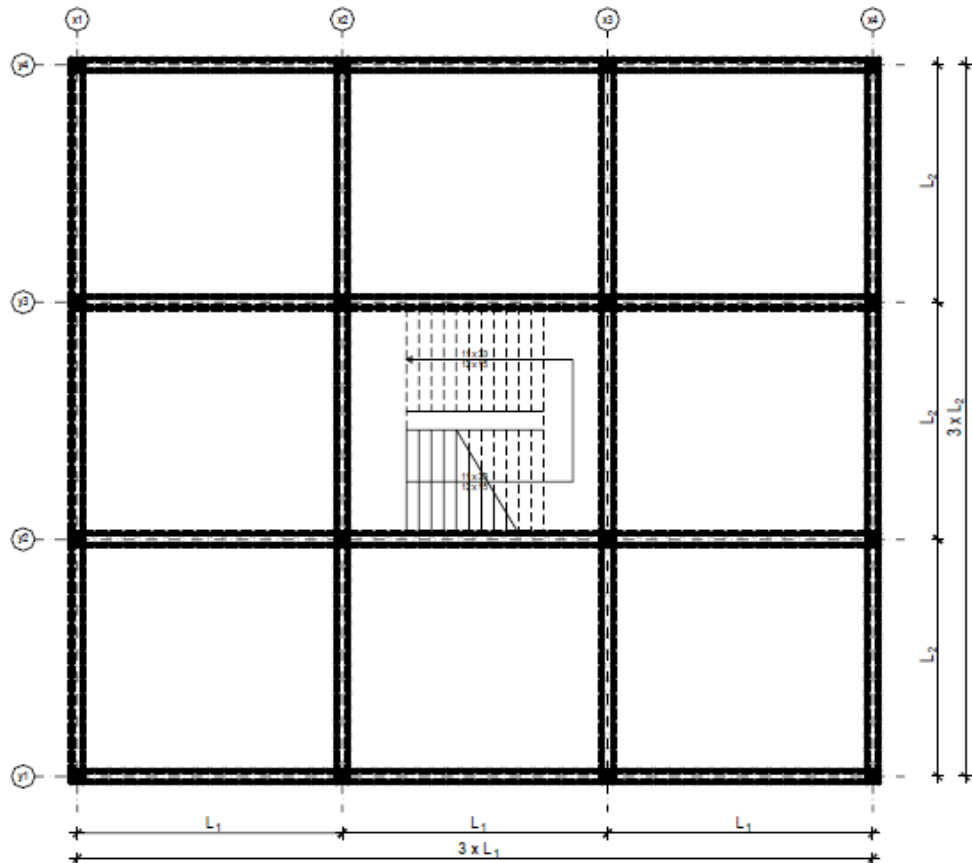

(iii) Krovna konstrukcija

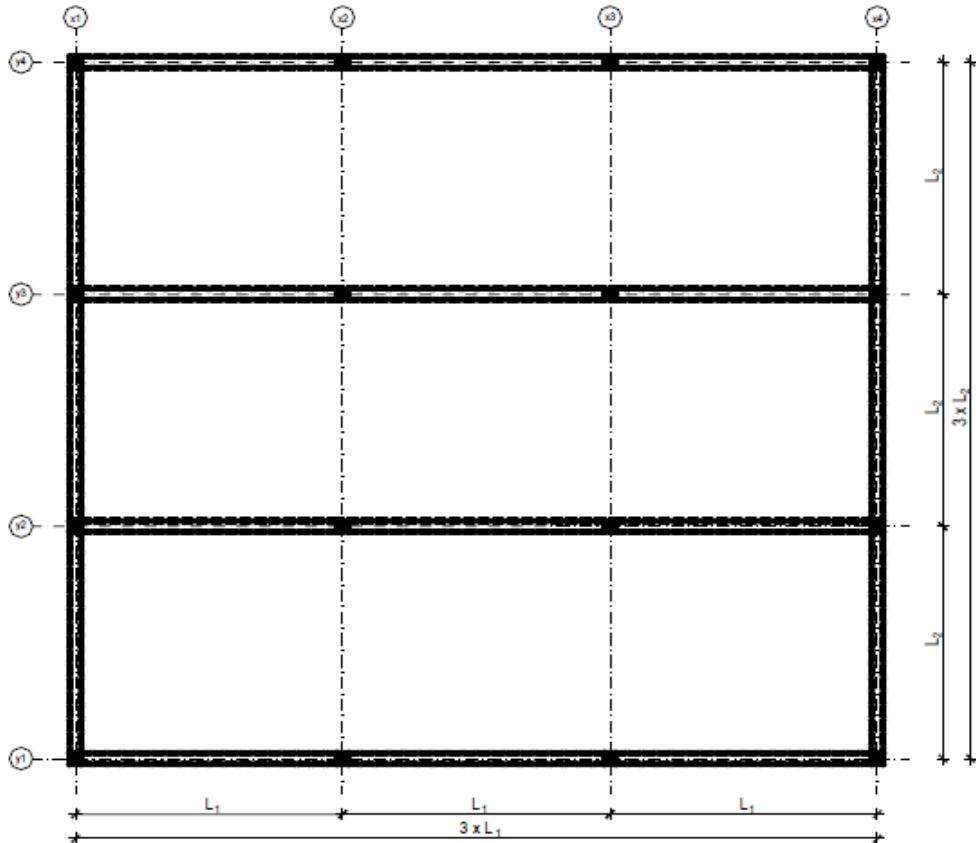

SAŽETAK:

Zadana je shema nosive konstrukcije armiranobetonskog objekta poslovne namjene sa svim potrebnim dimenzijama (prilog zadatku). Također su zadana djelovanja na konstrukciju, te za neke elemente nacrtati planove oplata i armature. Statički proračun i armaturne planove izraditi sukladno propisima i pravilima struke.

KLJUČNE RIJEČI:

Armiranobetonski objekt poslovne namjene, numerički model, statički proračun, plan armature.

ABSTRACT:

The default scheme bearing structures reinforced concrete facility for business purposes, with all the required dimensions (Annex task). Also the default action on the structure, and for some elements draw plans and reinforcement.

Structural analysis and reinforcement plans develop in accordance with the regulations and rules of the profession.

KEYWORDS:

Reinforced concrete building for business purposes, numerical model, static analysis, reinforcement plan.

SADRŽAJ:

1. TEHNIČKI OPIS	1
2. GEOMETRIJSKE KARAKTERISTIKE NOSIVIH ELEMENATA	2
3. ANALIZA OPTEREĆENJA	4
3.1. POZICIJA 200 – KROV	4
3.1.1. <i>Stalno opterećenje</i>	4
3.1.2. <i>Uporabno opterećenje</i>	4
3.2. POZICIJA 100 – ETAŽE	6
3.2.1. <i>Stalno opterećenje</i>	6
3.2.2. <i>Uporabno opterećenje</i>	6
3.3. STUBIŠTE	10
3.3.1. <i>Stalno opterećenje</i>	10
3.3.2. <i>Uporabno opterećenje</i>	11
3.4. OPTEREĆENJE VJETROM.....	12
4. PRORAČUN PLOČA POZICIJE 200.....	18
4.1. MOMENTI SAVIJANJA U PLOČI POZICIJE 200	18
4.1.1. <i>Vlastita težina</i>	18
4.1.2. <i>Dodatno stalno opterećenje</i>	20
4.1.3. <i>Uporabno opterećenje</i>	21
4.1.4. <i>Granično stanje nosivosti</i>	22
4.2. DIMENZIONIRANJE PLOČA POZICIJE 200	23
5. PRORAČUN PLOČA POZICIJE 100.....	26
5.1. MOMENTI SAVIJANJA U PLOČI POZICIJE 100	26
5.1.1. <i>Vlastita težina</i>	26
5.1.2. <i>Dodatno stalno opterećenje</i>	28
5.1.3. <i>Uporabno opterećenje shema 1 (max momenti na ležajevima)</i>	29
5.1.4. <i>Uporabno-opterećenje shema 2(max momenti u krajnjim poljima)</i>	30
5.1.5. <i>Uporabnoopterećenje shema 3 (max momenti u srednjem polju)</i>	31
5.1.6. <i>GSN za ležajeve</i>	32
5.1.7. <i>GSN za krajnja polja</i>	33
5.1.8. <i>GSN za srednje polje</i>	34
5.2. DIMENZIONIRANJE PLOČA POZICIJE 100	35
6. PRORAČUN KONTINUIRANOG NOSAČA POZICIJE 200.....	39
6.1. MOMENTI SAVIJANJA I POPREČNE SILE GREDE POZICIJE 200.....	39

6.1.1.	<i>Vlastita težina</i>	39
6.1.2.	<i>Dodatno stalno opterećenje</i>	40
6.1.3.	<i>Uporabnoopterećenje</i>	41
6.1.4.	<i>Granično stanje nosivosti</i>	42
6.2.	DIMENZIONIRANJE GREDE NA MOMENT SAVIJANJA	43
6.3.	DIMENZIONIRANJE GREDE NA POPREČNU SILU	45
6.4.	KONTROLA PUKOTINA GREDE POZICIJE 200.....	49
6.5.	KONTROLA PROGIBA GREDE POZICIJE 200	53
7.	PRORAČUN KONTINUIRANOG NOSAČA POZICIJE 100	56
7.1.	MOMENTI SAVIJANJA I POPREČNE SILE GREDE POZICIJE 100.....	56
7.1.1.	<i>Vlastita težina</i>	56
7.1.2.	<i>Dodatno stalno opterećenje</i>	57
7.1.3.	<i>Uporabno opterećenje shema 4 (max sile u krajnjim poljima)</i>	58
7.1.4.	<i>Uporabno opterećenje shema 5 (max sile u srednjem polju)</i>	59
7.1.5.	<i>Uporabno opterećenje shema 6 (max sile na ležaju)</i>	60
7.1.6.	<i>GSN za kranjapolja</i>	61
7.1.7.	<i>GSN za srednje polje</i>	62
7.1.8.	<i>GSN za ležaj</i>	63
7.2.	DIMENZIONIRANJE GREDE NA MOMENT SAVIJANJA	64
7.3.	DIMENZIONIRANJE GREDE NA POPREČNU SILU	66
7.4.	KONTROLA PUKOTINA GREDE POZICIJE 100.....	70
7.5.	KONTROLA PROGIBA GREDE POZICIJE 100	74
8.	PRORAČUN STUBIŠTA	77
8.1.	MJERODAVNE REZNE SILE	77
8.2.	DIMENZIONIRANJE STUBIŠTA	78
9.	PRORAČUN STUPOVA	79
9.1.	MOMENTI SAVIJANJA I UZDUŽNE SILE STUPOVA	79
9.1.1.	<i>Kombinacija 1</i>	79
9.1.2.	<i>Kombinacija 2</i>	80
9.2.	DIMENZIONIRANJE STUPA	81
9.2.1.	<i>Određivanje dimenzija stupova</i>	81
9.2.2.	<i>Dimenzioniranje pomoću dijagrama interakcije</i>	82
9.2.3.	<i>Proračun poprečne armature stupa</i>	83
10.	PRORAČUN TEMELJA SAMCA ISPOD STUPA	83
10.1.	DIMENZIONIRANJE TEMELJA.....	83

10.1.1.	<i>Preliminarno određivanje dimenzija temelja</i>	84
10.2.	NAPREZANJA NA DODIRNOJ PLOHI TEMELJ – TLO.....	85
10.3.	PRORAČUN ARMATURE TEMELJA	86
11.	PRILOZI	88
11.1.	ARMATURA PLOČE POZICIJA 100- DONJA ZONA	88
11.2.	ARMATURA PLOČE POZICIJA 100- GORNJA ZONA.....	88
11.3.	ARMATURA PLOČE POZICIJA 200- DONJA ZONA.....	88
11.4.	ARMATURA PLOČE POZICIJA 200- GORNJA ZONA.....	88
11.5.	ARMATURNI PLAN GREDE POZICIJE 100.....	88
11.6.	ARMATURNI PLAN GREDE POZICIJE 200.....	88
11.7.	ARMATURNI PLAN STUBIŠTA	88
11.8.	ARMATURNI PLAN STUPA.....	88
12.	LITERATURA	89

1. TEHNIČKI OPIS

Predmet ovog rada je projekt armiranobetonske nosive konstrukcije poslovnog objekta. Predmetna građevina sastoji se od prizemlja i kata. Završna ploča kata je ujedno i ravni krov građevine.

Visina građevine iznosi 6,00 m, a tlocrtna površina građevine iznosi 20,70 x 18,60 m.

Nosiva konstrukcija objekta je okvirna, a čine je stupovi i grede iznad koje su armiranobetonske ploče. Stupovi se oslanjaju na temelje samce. Rezne sile u pločama i gredama dobivene su pomoću programa *AspalathosLinear*, a korišten je ravninski model. Sve armiranobetonske ploče su debljine $d=18.0\text{cm}$. Poprečne grede su dimenzija $b/h=30/60\text{ cm}$, a uzdužne grede dimenzija $b/h=30/60\text{ cm}$. Rezne sile u stupovima za različite kombinacije opterećenja dobivene su pomoću programa *AspalathosLinear*, a korišten je prostorni model (okvir). Odabrane su dimenzije stupova $35/35\text{ cm}$ i temelji samci $210\times 210\times 70\text{ cm}$. Za vertikalnu komunikaciju između katova predviđeno je armiranobetonsko stepenište debljine nosive ploče $d=18.0\text{ cm}$.

Izračunato stalno opterećenje za poziciju 200(krov) iznosi $8,50\text{ kN/m}^2$, a uporabno opterećenje (prema propisima) iznosi $1,0\text{ kN/m}^2$. Zadano je uporabno opterećenje za poziciju 100 (međukatne konstrukcije) i iznosi $3,5\text{ kN/m}^2$, a stalno opterećenje je $7,70\text{ kN/m}^2$. Građevina se nalazi u III. vjetrovnoj zoni s osnovnom brzinom vjetra $v_{b0}=35\text{ m/s}$.

Dozvoljeno naprezanje u tlu na dubini temeljenja iznosi $\sigma_{\text{dop}} = 0.50\text{ Ma}$.

Za nosivu armiranobetonsku konstrukciju odabran je beton C 40/50 i čelik za armiranje B 500B.

Za sve armiranobetonske nosive elemente izvršen je proračun za granično stanje nosivosti, a za neke elemente izvršena je provjera graničnog stanja uporabljivosti. Na osnovi proračunskih vrijednosti momenata i dobivenih površina armature, odabrana je armatura (mreže i šipki) te su napravljeni armaturni planovi za neke elemente konstrukcije. Svi nacrti i prikazi krojenja armaturnih mreža ploče, grede i stupova nacrtani su pomoću programa AutoCAD priloženi su u radu.

Statički sustav i armaturni planovi izrađeni su sukladno propisima i pravilima struke.

2. GEOMETRIJSKE KARAKTERISTIKE NOSIVIHELEMENATA

-visina ploče:

$$d_{pl} = \frac{L_2}{35} = \frac{620}{35} = 17,7$$

⇒ odabrano: $d_{pl} = 18\text{cm}$

visina grede:

$$\frac{L_0}{12} = \frac{L_1}{12} = \frac{690}{12} = 57,5\text{cm}$$

odabrano: $h_{G1} = 60,0\text{cm}$

$$\frac{L_0}{12} = \frac{L_1}{12} = \frac{620}{12} = 51,6\text{cm}$$

odabrano: $h_{G1} = 60,0\text{cm}$

-širina grede:

$$\frac{h_{G1}}{2} = \frac{60}{2} = 30\text{cm}$$

odabrano: $b_{G1} = 30\text{cm}$

$$\frac{h_{G2}}{2} = \frac{60}{2} = 30\text{cm}$$

odabrano: $b_{G2} = 30\text{cm}$

PRESJEK 1

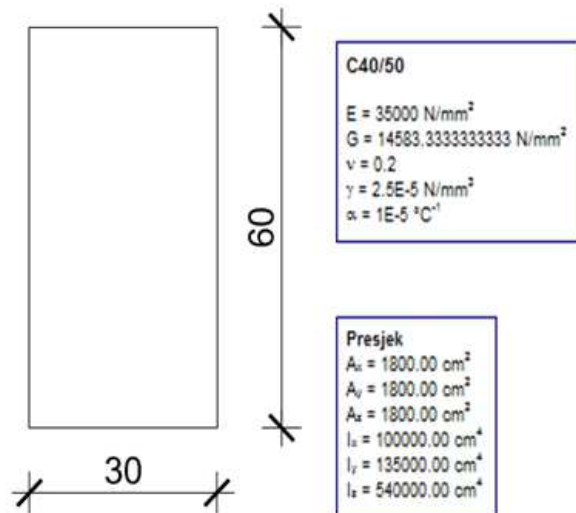

Slika 2.1. Poprečni presjek grede

- Za sve nosive elemente u x i y smjeru na pozicijama 100 i 200 odabran je isti presjek grede, dimenzija 60x30 cm.

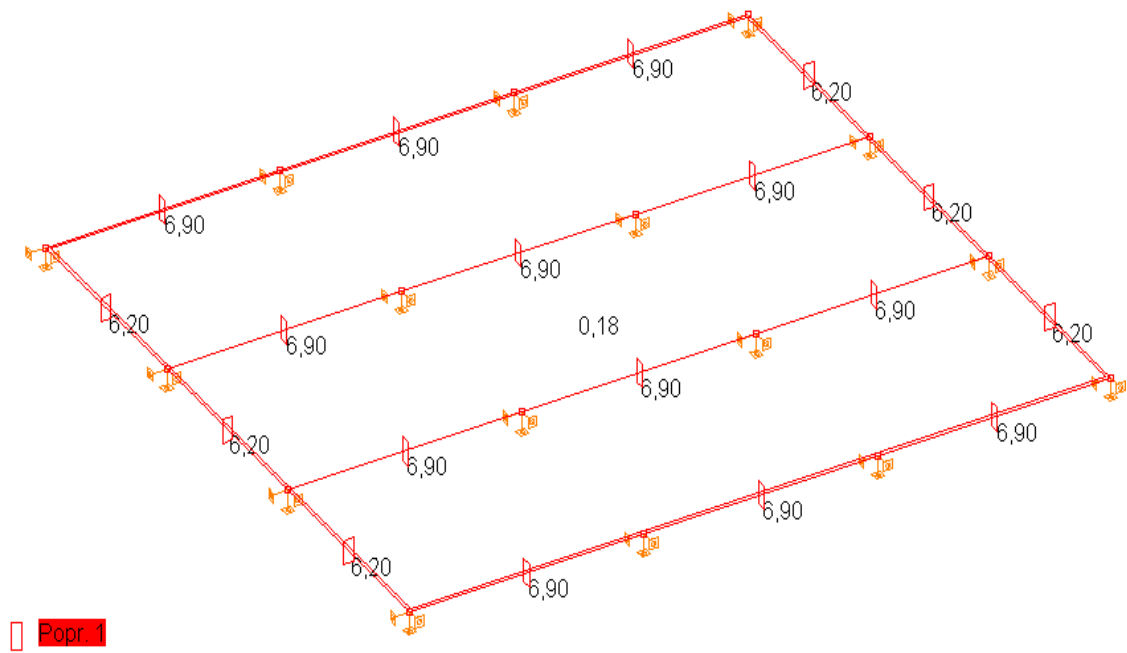

Slika 2.2. Prikaz dimenzija greda i pločapoz. 200

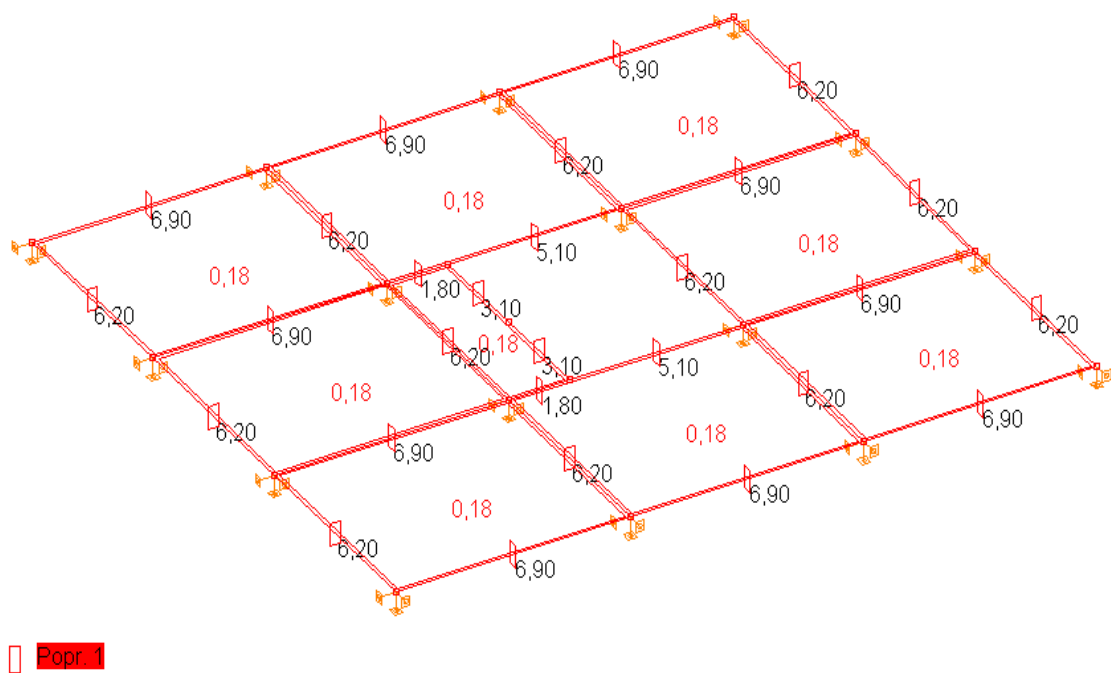

Slika 2.3. Prikaz dimenzija greda i ploča poz. 100

3. ANALIZA OPTEREĆENJA

3.1. POZICIJA 200 – KROV

3.1.1. Stalno opterećenje

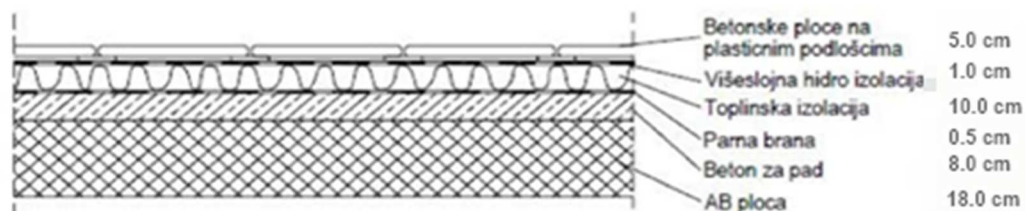

Slika 3.1. Presjek ploče poz. 200

Tablica 3.1. Stalno opterećenje poz.200

	d (m)	γ (kN/m ³)	d· γ (kN/m ²)
Betonske ploče na plastičnim podloščima	0.05	25.0	1.25
Hidroizolacija + parna brana	0.01	20.0	0.20
Toplinska izolacija	0.10	5.0	0.50
Beton za pad	0.08	24.0	1.92
AB ploča	0.18	25.0	4.5

Ukupno stalno opterećenje: $g_{200} = 8.50$ (kN/m²)

3.1.2. Uporabno opterećenje

Za uporabno opterećenje uzima se opterećenje snijegom i vjetrom. Opterećenje snijegom za ravnekrovove, u područjima gdje je snijeg rijedak (prema pravilniku) iznosi 0.50 kN/m², pa se za uporabno opterećenje neprohodnih ravnih krovova može uzeti zamjenjujuća vrijednost:

$$q_{200} = s + w \approx 1.0 \text{ kN/m}^2$$

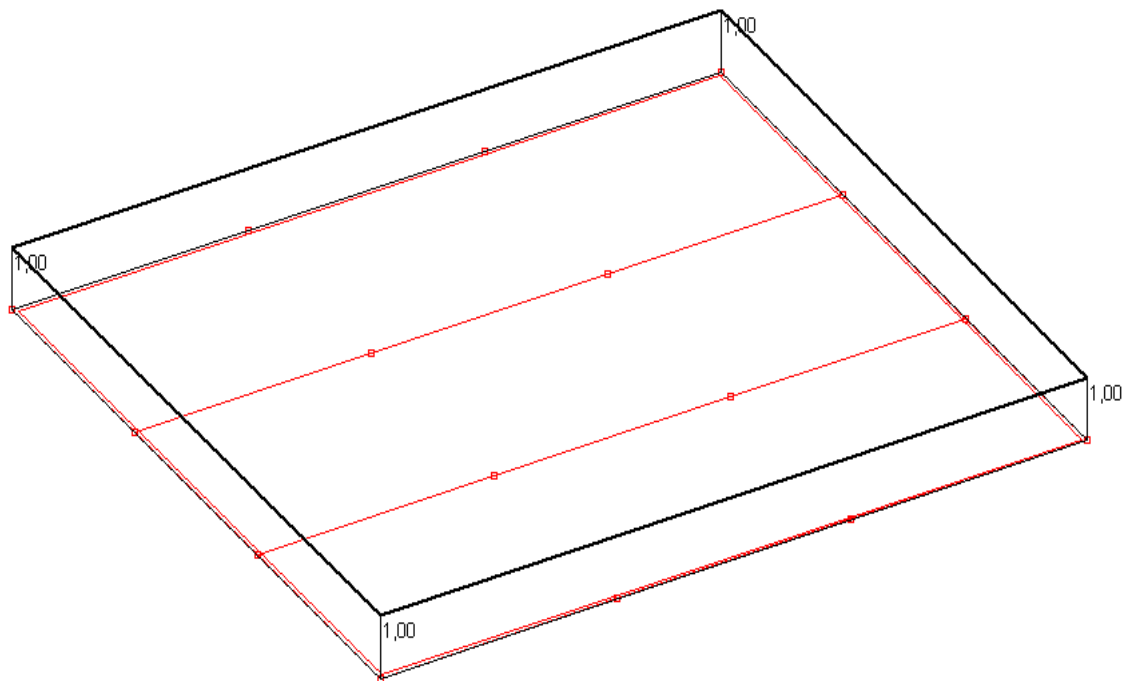
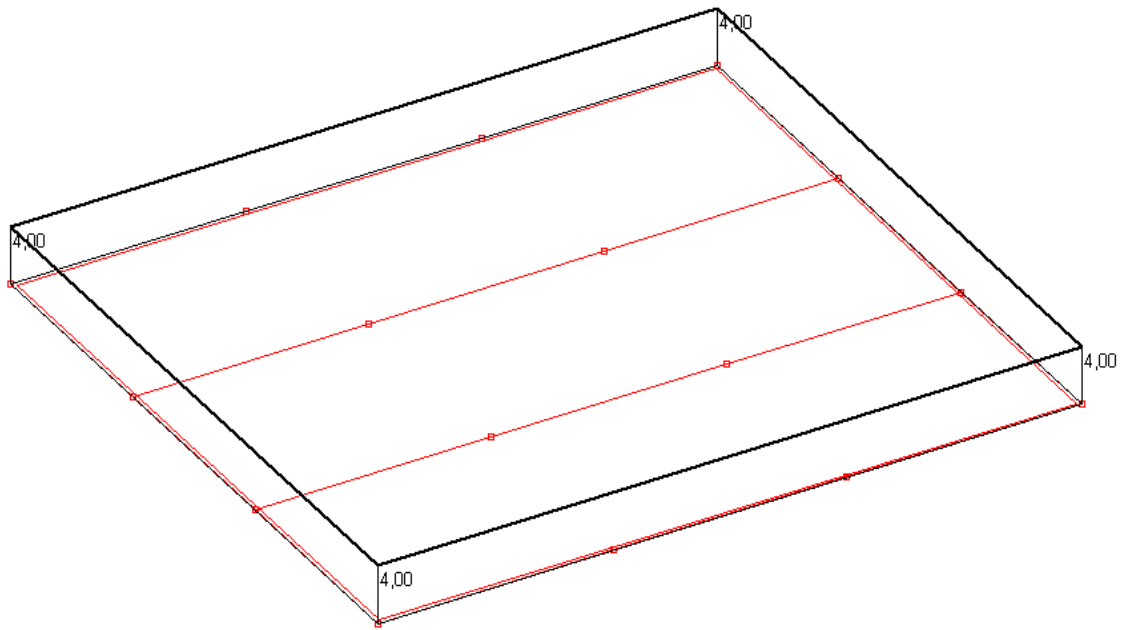

Slika 3.2. Prikaz dodatnog stalnog opterećenja G_0 i uporabnog opterećenja Q

3.2. POZICIJA 100 – ETAŽE

3.2.1. Stalno opterećenje

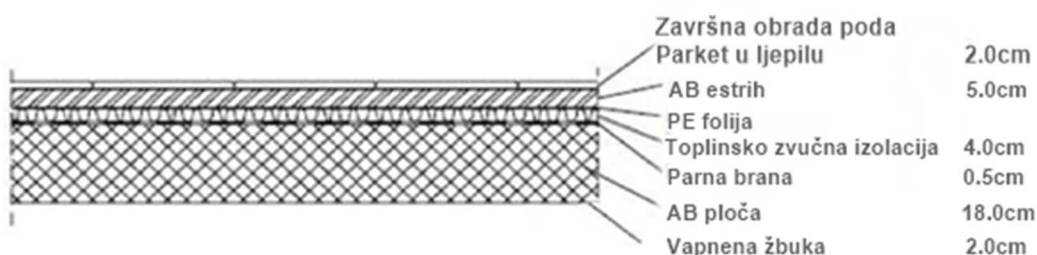

Slika 3.3. Presjek ploče poz. 100

Tablica 3.2. Stalno opterećenje poz. 100

	d (m)	γ (kN/m ³)	d· γ (kN/m ²)
Pregrade			1.00
Završna obrada poda-parket	0.02	12.0	0.24
AB estrih	0.05	25.0	1.25
Toplinska izolacija	0.04	5.0	0.20
Hidroizolacija	0.005	20.0	0.10
AB. Ploča	0.18	25.0	4.50
Pogled (vapnena žbuka)	0,02	19,00	0,38

Ukupno stalno opterećenje $g_{100} = 7,70$ (kN/m²)

3.2.2. Uporabno opterećenje

Uporabno opterećenje se uzima prema pravilniku: HRN EN 1991-2-1.

U našem slučaju, zadano je zadatkom $q_{100} = 3.5$ kN/m²

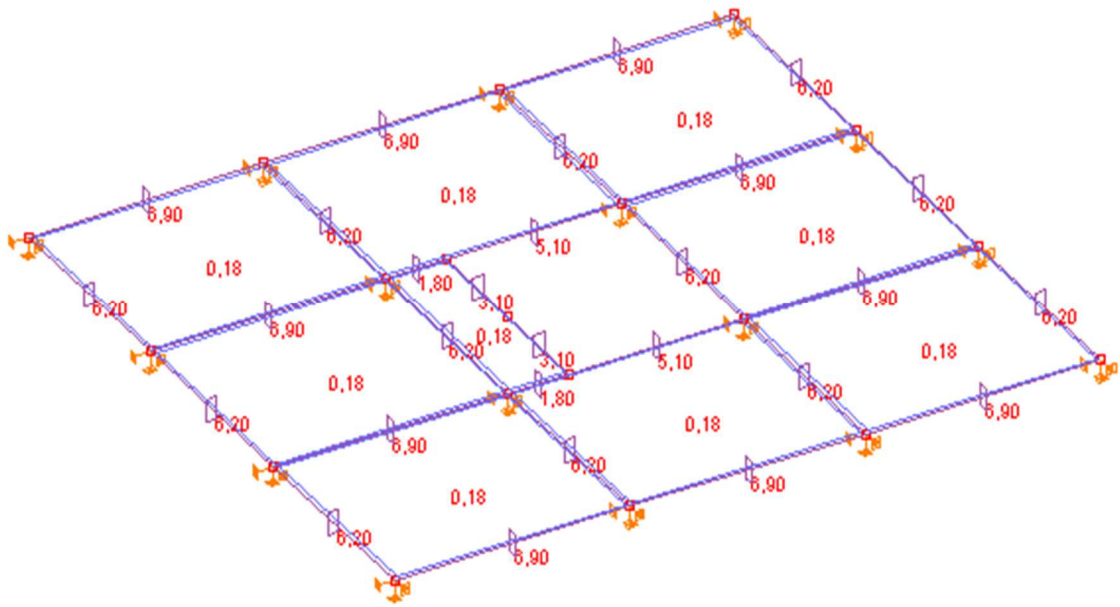

Slika 3.4. Geometrija etaže 100

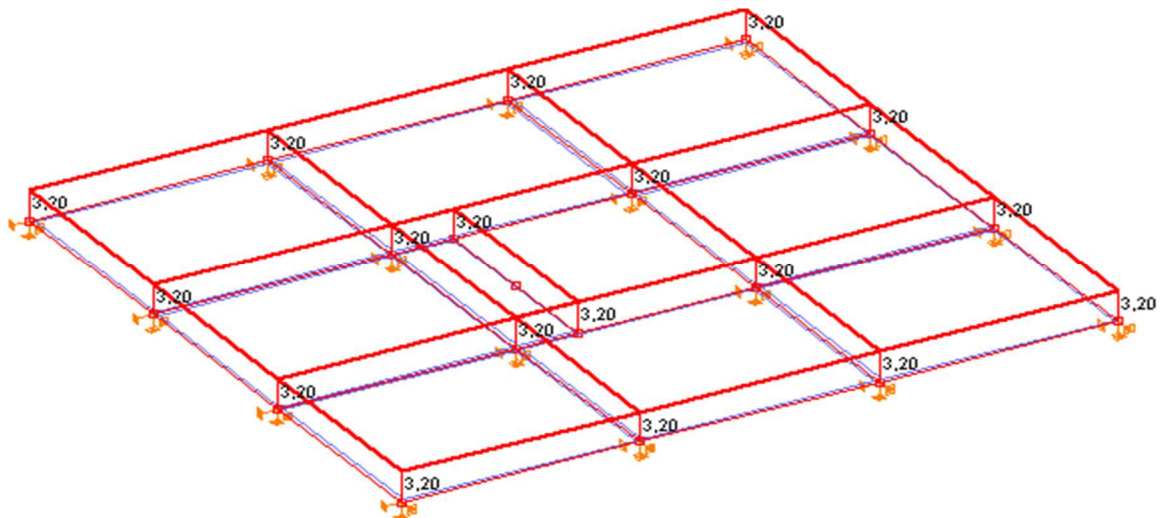

Slika 3.5 Prikaz dodatnog stalnog opterećenja G_0

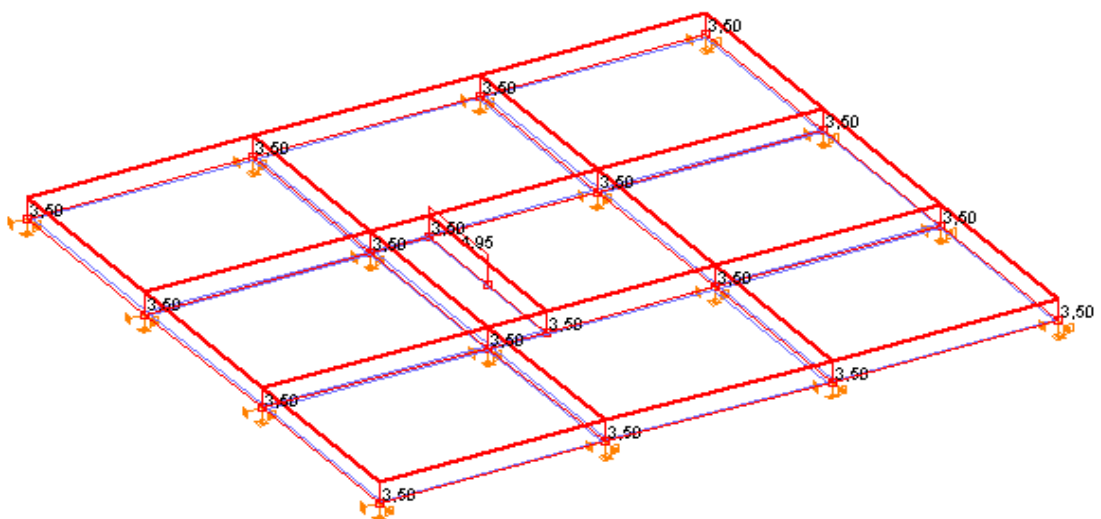

Slika 3.6 Prikaz uporabnog opterećenja shema 1 (max sile na ležajevima kod ploča)

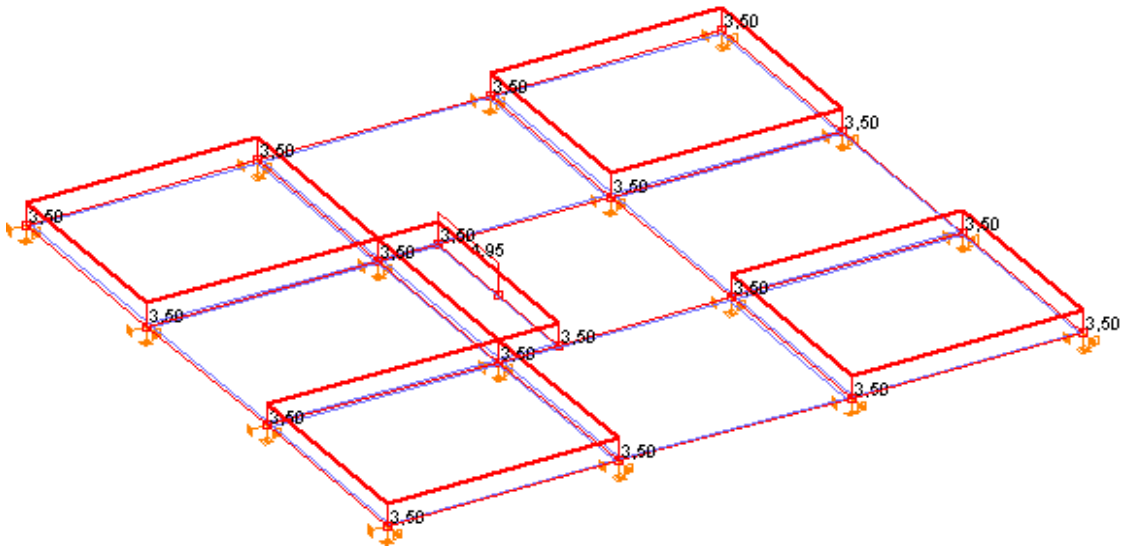

Slika 3.7. Prikaz uporabnog opterećenja shema 2(max sile u krajnjim poljima kod ploča)

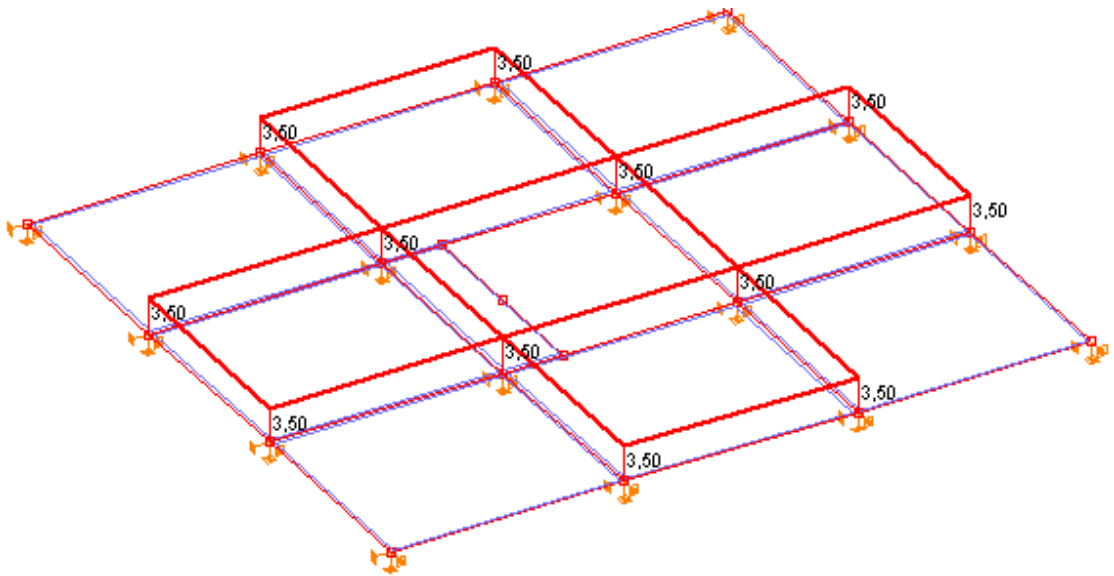

Slika 3.8. Prikaz uporabnog opterećenja shema 3(max sile u srednjem polju kod ploča)

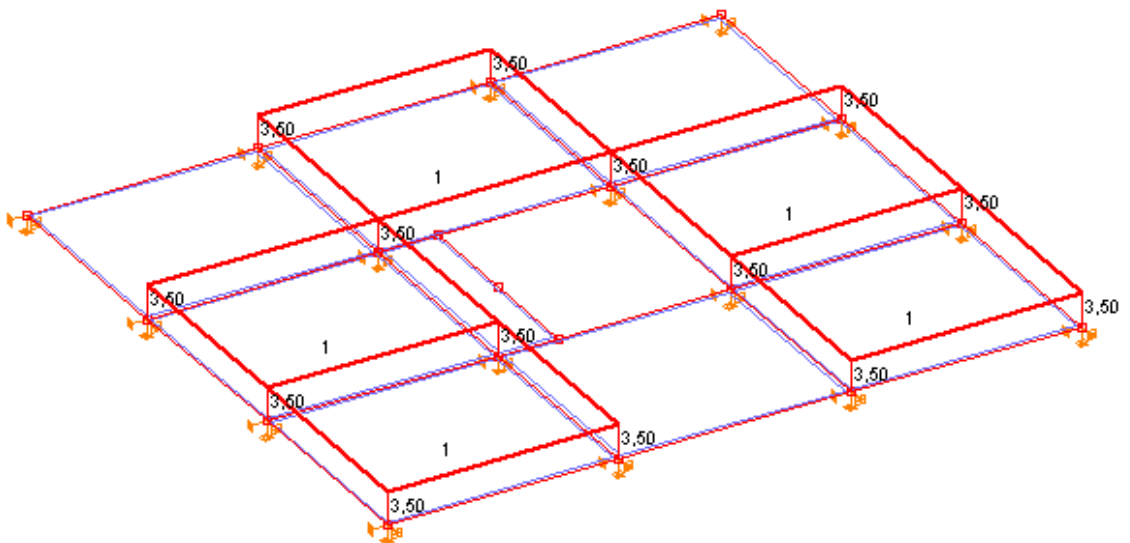

Slika 3.9. Prikaz uporabnog opterećenja shema 4(max sile u krajnjem polju kod grede)

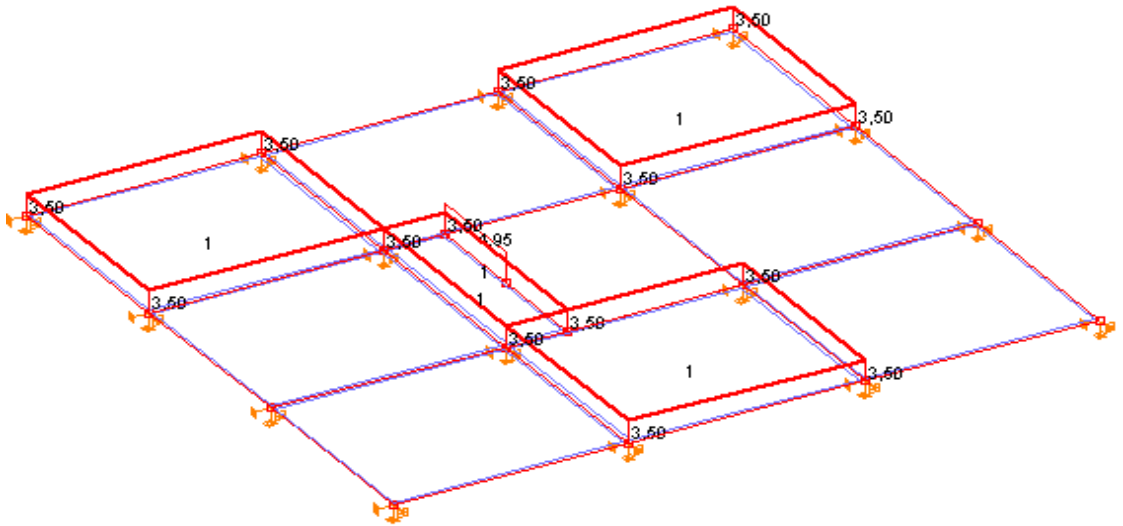

Slika 3.10. Prikaz uporabnog opterećenja shema 5 (max sile u srednjem polju kod grede)

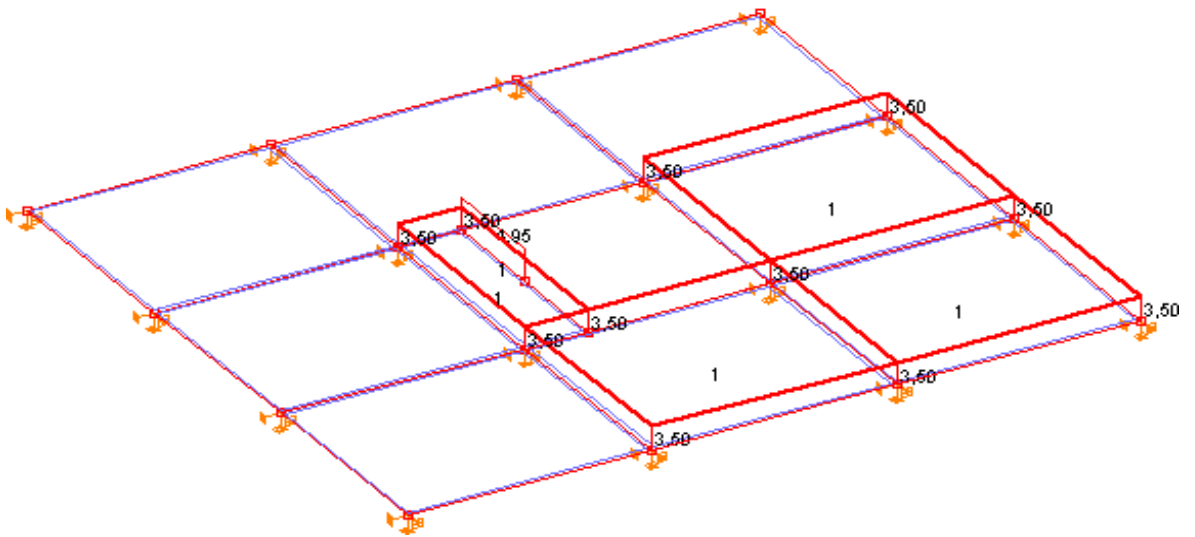

Slika 3.11. Prikaz uporabnog opterećenja shema 6(max sile na ležaju kod grede)

3.3. STUBIŠTE

3.3.1. Stalno opterećenje

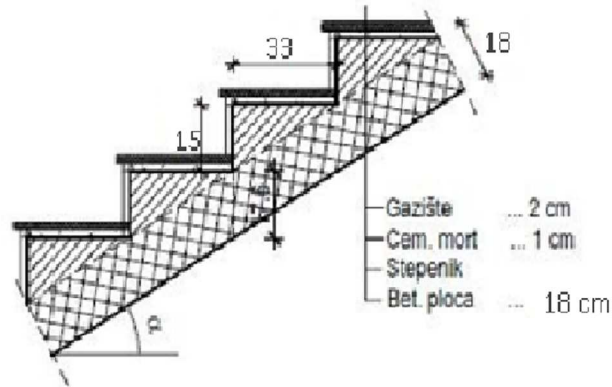

Slika 3.12. Presjek stubišta

- Broj stuba (za jedan stubišni krak):

$$n_s = H/2 \cdot v = 3,00/2 \cdot 0,15 = 10 \text{ stuba}$$

- Širina stube:

$$2 \cdot v_s + \text{šs} = 63 \Rightarrow \text{šs} = 63 - 2 \cdot 0,15 = 33 \text{ cm}$$

- Duljina kraka:

$$L_k = n_s \cdot \text{šs} = 10 \cdot 33 = 330 \text{ cm}$$

- Kut α :

$$\text{tg} \alpha = 0,5 \cdot H/L_k = 1,5 \cdot 3,3 = 0,455 \Rightarrow$$

$$\alpha = 24,44^\circ$$

- Odabrana duljina podesta:

$$L_p \geq 1,20 \text{ m} \quad L_p = (L - L_k)/2 = (6,9 - 3,3)/2 = 1,8 \text{ m}$$

$$h' = \frac{h}{\cos \alpha} = \frac{18}{\cos 24,44} = 19,77 \text{ cm}$$

Tablica 3.3. Stalno opterećenje stubišta

	d (m)	γ (kN/m ³)	d· γ (kN/m ²)
Završna obrada gazišta – kamena ploča	0.02	28.0	0.56
Cementni namaz (max. 1,0 cm)	0.01	20.0	0.20
Stub	0.075	24.0	1.80
AB ploča (h'=19,77 cm)	0.198	25.0	4,95

Ukupno stalno opterećenje : $g_{st} = 7,31$ (kN/m²)

3.3.2. *Uporabno opterećenje*

Uporabno opterećenje se uzima prema pravilniku: HRN EN 1991-2-1.

U našem slučaju, uzet ćemo ga jednako kao na pločama:

$q_{st} = 4,95$ (kN/m²)

3.4. OPTEREĆENJE VJETROM

Dimenzije zgrade su: $L_1=6.9\text{m}, L_2=6.2\text{m}, H=3.0\text{m}$.

Objekt se nalazi u III. vjetrovnoj zoni, na visini od 150 m.n.m

Osnovna brzina vjetra: $v_{b,0} = 35 \text{ m/s}$ (za III. Zonu)

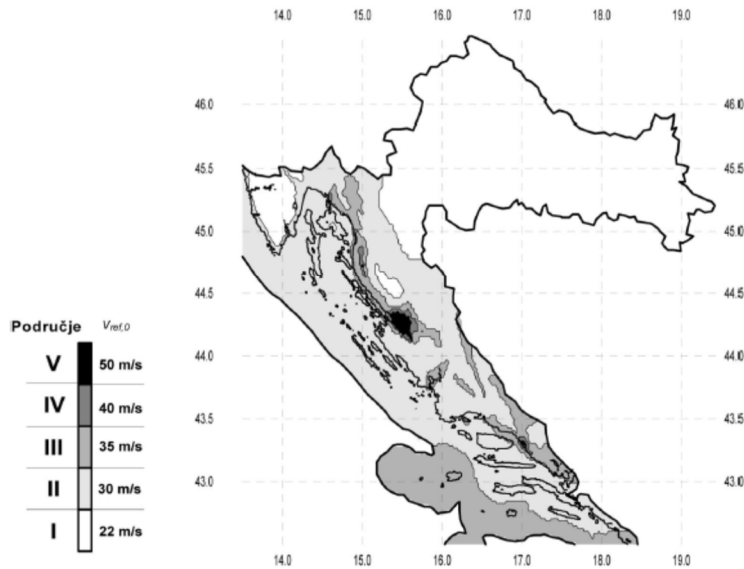

Slika 3.13. Zemljovid područja opterećenja vjetrom

Referentna brzina vjetra: $v_b = c_{DIR} \cdot c_{TEM} \cdot c_{ALT} \cdot v_{b,0}$

c_{DIR} - koeficijent smjera vjetra $\rightarrow c_{DIR} = 1.0$

c_{TEM} - koeficijent ovisan o godišnjem dobu $\rightarrow c_{TEM} = 1.0$

c_{ALT} - koeficijent nadmorske visine $\rightarrow c_{ALT} = 1 + 0,0001 \cdot a_s$

$$c_{ALT} = 1 + 0,0001 \cdot 150 = 1,015$$

$$v_b = 1,00 \cdot 1,00 \cdot 1,015 \cdot 35 = 35,525 \text{ m/s}$$

Zgrada ima veću širinu od visine, a za mjerodavnu visinu uzimamo ukupnu visinu.

Pretpostavimo da je na vrhu izgrađen AB parapet visine 0,5 m, mjerodavna visina tada iznosi:

$$z_e = 2 \cdot 3,0 + 0,5 = 6,5 \text{ m}$$

Mjerodavna visina je veća od minimalne (2,00 m), pa je koeficijent hrapavosti:

$$c_{r(z)} = k_r \cdot \ln\left(\frac{z_e}{z_0}\right)$$

Koeficijent terena k_r određuje se iz odgovarajuće tablice ovisno o kategoriji zemljišta.

Odabiremo III. kategoriju zemljišta.

Tablica 3.4. Kategorije terena i pripadni parametri

Kategorija terena	Opis	K_r	z_0 [m]	Z_{min} [m]
0	More ili područje uz more otvoreno prema moru	0.156	0.003	1
I	Uzburkano otvoreno more ili jezero, s najmanje 5 km dužine navjetrine i gladak ravan teren bez prepreka	0.170	0.01	1
II	Poljoprivredno zemljište s ogradama, povremenim malim poljoprivrednim objektima, kućama ili drvećem	0.190	0.05	2
III	Predgrađa ili industrijske zone i stalne šume	0.215	0.30	5
IV	Urbane zone u kojima je najmanje 15% površine pokriveno zgradama čija je srednja visina veća od 15 m	0.234	1.00	10

$$k_r = 0,215 \rightarrow c_{r(z)} = 0,215 \cdot \ln\left(\frac{6,5}{0,30}\right) = 0,661$$

Srednja brzina vjetra tako iznosi: $V_m(z) = C_r(z) \cdot C_0(z) \cdot V_b$

C_0 - koeficijent topografije (uglavnom se uzima 1.0)

$$v_m = 0,661 \cdot 1,0 \cdot 35,525 = 23,48 \text{ m/s}$$

Turbulencija:

$$I_v(z) = \frac{1}{c_0(z) \cdot \ln\left(\frac{z_e}{z_0}\right)} = \frac{1}{1,0 \cdot \ln\left(\frac{6,5}{0,30}\right)} = 0,325$$

Maksimalni tlak pri vršnoj brzini $q_p(z_e)$:

$$\rho_{zr} = 1,25 \text{ kg/m}^3$$

$$q_p(z) = [1 + 7 \cdot I_v(z)] \cdot \frac{\rho_{zr}}{2} \cdot v_m^2(z) = c_e(z) \cdot v_b(z)$$

$$q_p(z) = [1 + 7 \cdot 0,325] \cdot \frac{1,25}{2} \cdot 23,48^2 = 1128,46 \frac{\text{N}}{\text{m}^2} = 1,13 \frac{\text{kN}}{\text{m}^2}$$

Djelovanje na zgradu:

$$w_{1,e} = 0,8 \cdot q_p(z) = 0,8 \cdot 1,13 = 0,90 \frac{kN}{m^2}$$

$$w_{2,e} = 0,5 \cdot q_p(z) = 0,5 \cdot 1,13 = 0,57 \frac{kN}{m^2}$$

$$w_{1,l} = 0,75 \cdot w_{1,e} = 0,75 \cdot 0,90 = 0,68 \frac{kN}{m^2}$$

$$w_{2,l} = 0,75 \cdot w_{2,e} = 0,75 \cdot 0,57 = 0,43 \frac{kN}{m^2}$$

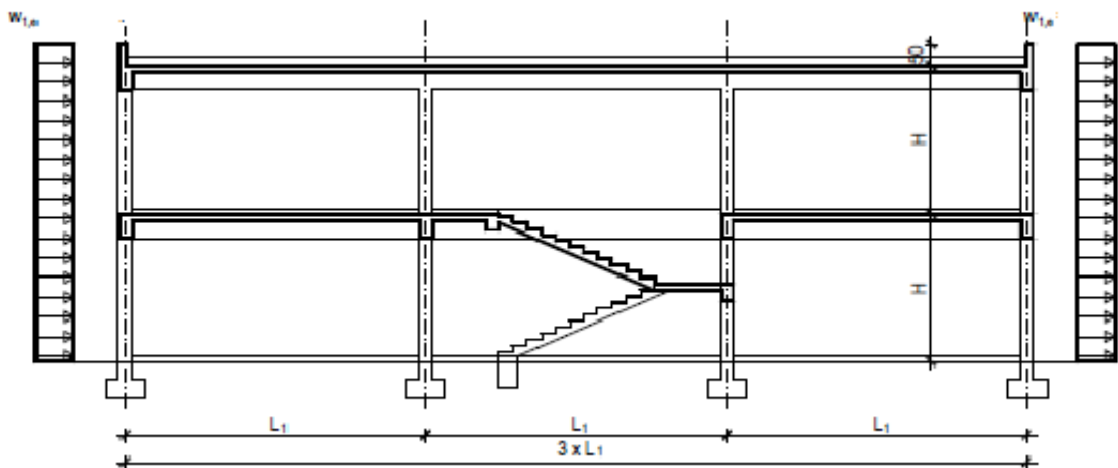

Slika 3.14. Opterećenje vjetrom

Silu vjetra zadajemo u čvorovima modela. Određivanje sila u čvorovima modela vršimo prema utjecajnim površinama djelovanja vjetra.

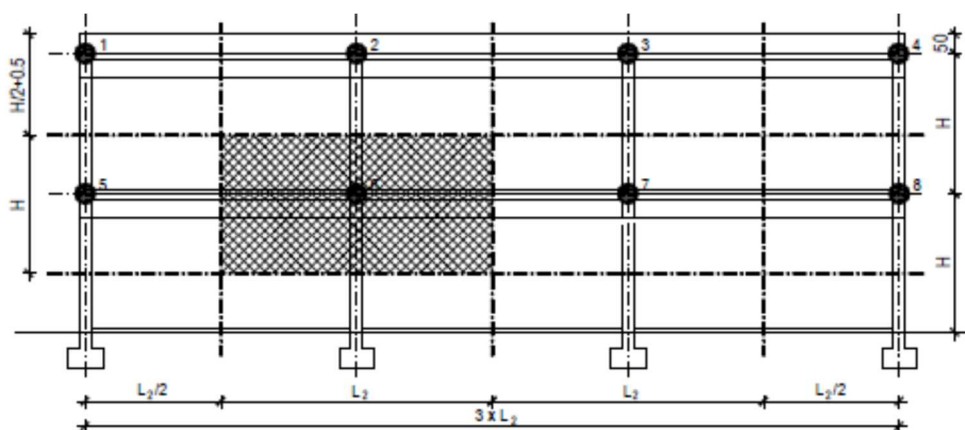

Slika 3.15. Utjecajne površine djelovanja vjetra

➤ **X smjer**

Tablica 3.5. Lijevi bok

Čvor	Utjecajna površina			Tlak vjetra(kN/m ²)	Sila u čvoru(kN)
	Širina(m)	Visina(m)	Površina(m ²)		
1	3.10	2.0	6.20	0.90	6.580
2	6.20	2.0	12.40	0.90	11.160
3	6.20	2.0	12.40	0.90	11.160
4	3.10	2.0	6.20	0.90	6.580
5	3.10	3.0	9.30	0.90	8.370
6	6.20	3.0	18.60	0.90	16.740
7	6.20	3.0	18.60	0.90	16.740
8	3.10	3.0	9.30	0.90	8.370

Tablica 3.6. Desni bok

Čvor	Utjecajna površina			Tlak vjetra(kN/m ²)	Sila u čvoru(kN)
	Širina(m)	Visina(m)	Površina(m ²)		
1	3.10	2.0	6.20	0.57	3.534
2	6.20	2.0	12.40	0.57	7.068
3	6.20	2.0	12.40	0.57	7.068
4	3.10	2.0	6.20	0.57	3.534
5	3.10	3.0	9.30	0.57	5.301
6	6.20	3.0	18.60	0.57	10.602
7	6.20	3.0	18.60	0.57	10.602
8	3.10	3.0	9.30	0.57	5.301

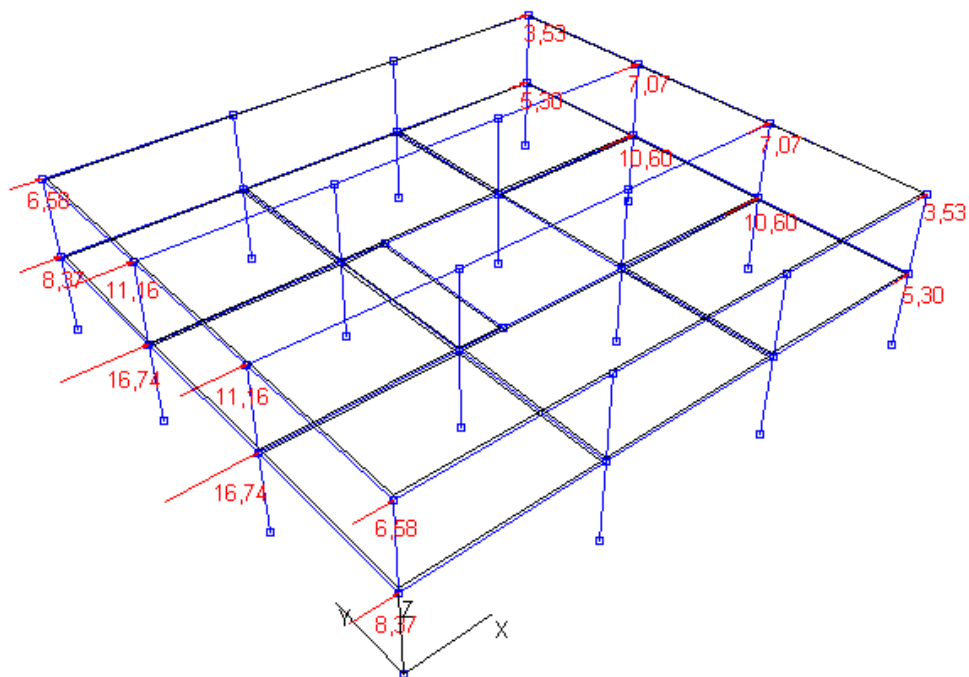

Slika 3.16. Djelovanje vjetra u X smjeru (sile u kN)

➤ **Y smjer**

Tablica 3.7. Prednja strana

Čvor	Utjecajna površina			Tlak vjetra(kN/m ²)	Sila u čvoru(kN)
	Širina(m)	Visina(m)	Površina(m ²)		
1	3.45	2.0	6.90	0.90	6.210
2	6.90	2.0	13.80	0.90	14.420
3	6.90	2.0	13.80	0.90	14.420
4	3.45	2.0	6.90	0.90	6.210
5	3.45	3.0	10.35	0.90	9.315
6	6.90	3.0	20.70	0.90	18.630
7	6.90	3.0	20.70	0.90	18.630
8	3.45	3.0	10.35	0.90	9.315

Tablica 3.8. Stražnja strana

Čvor	Utjecajna površina			Tlak vjetra(kN/m ²)	Sila u čvoru(kN)
	Širina(m)	Visina(m)	Površina(m ²)		
1	3.45	2.0	6.90	0.57	3.933
2	6.90	2.0	13.80	0.57	7.866
3	6.90	2.0	13.80	0.57	7.866
4	3.45	2.0	6.90	0.57	3.933
5	3.45	3.0	10.35	0.57	5.899
6	6.90	3.0	20.70	0.57	11.799
7	6.90	3.0	20.70	0.57	11.799
8	3.45	3.0	10.35	0.57	5.899

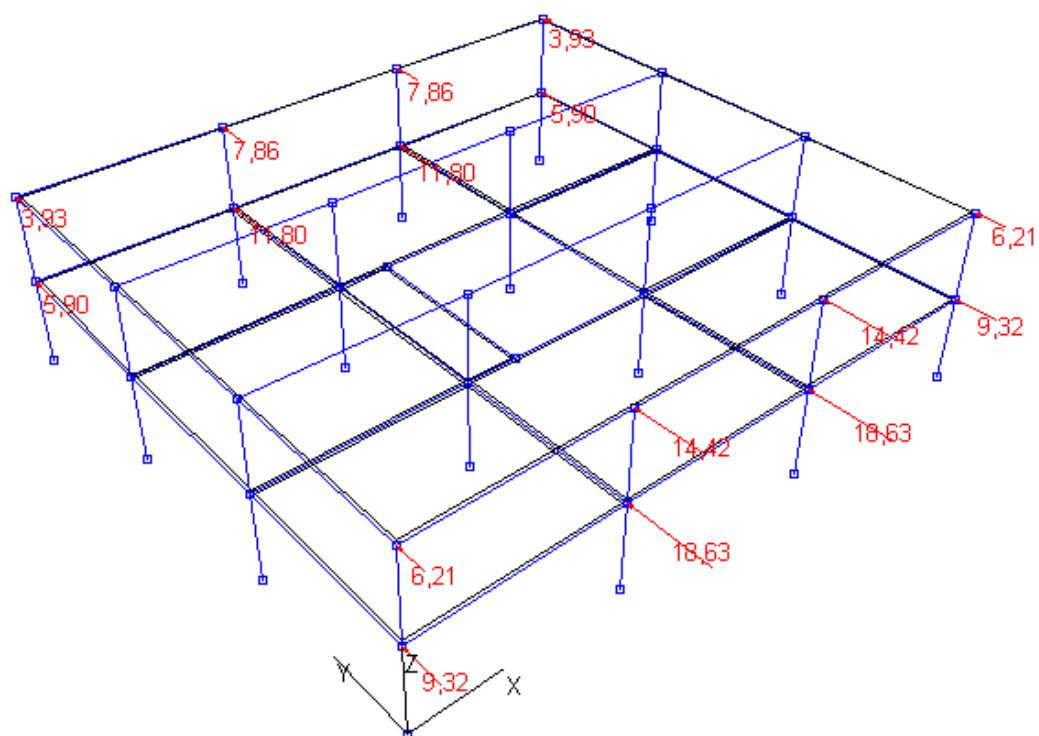

Slika 3.17. Djelovanje vjetra u Y smjeru (sile u kN)

4. PRORAČUN PLOČA POZICIJE 200

- Proračun reznih sila vršio se kompjuterskim programom *AspalathosLinear*. Prikaz rezultata dan je odvojeno za ploče i grede.

4.1. MOMENTI SAVIJANJA U PLOČI POZICIJE 200

4.1.1. Vlastita težina

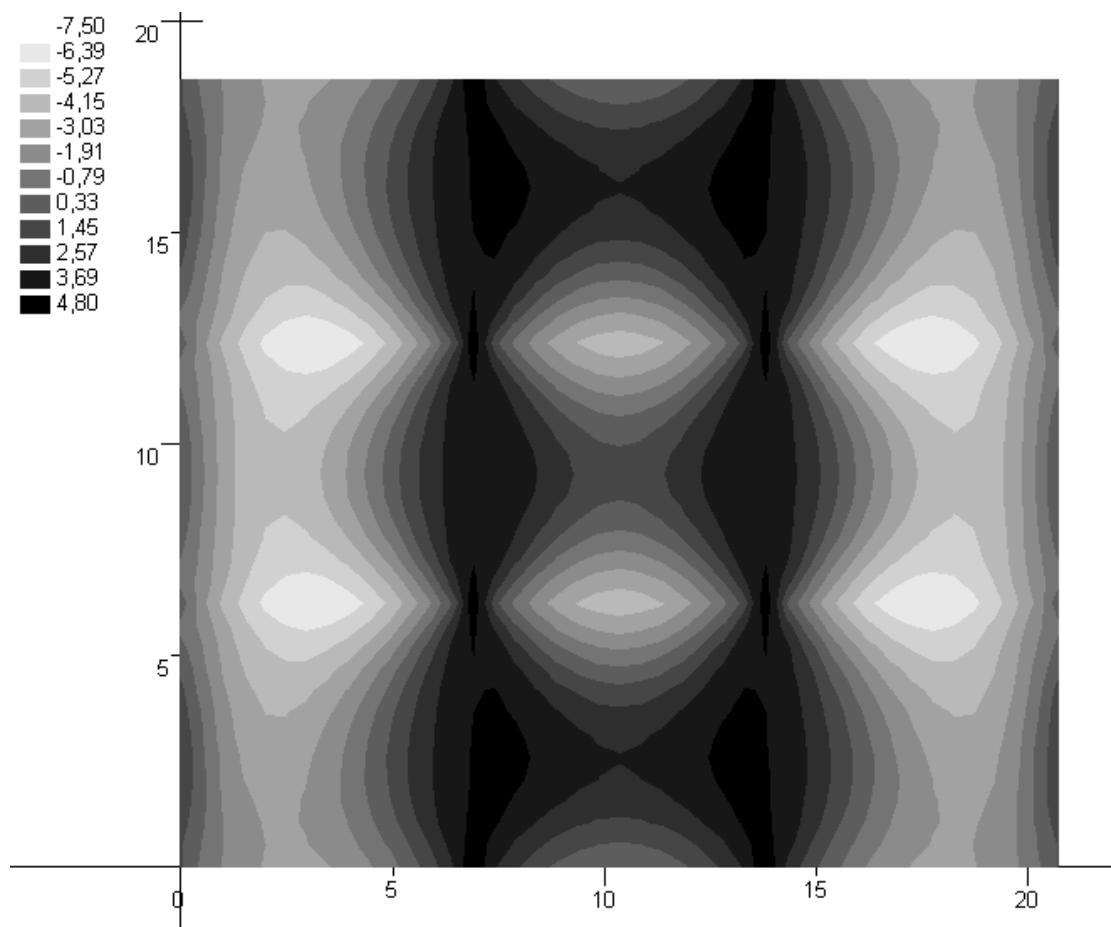

Slika 4.1. Momenti M_x (kNm)

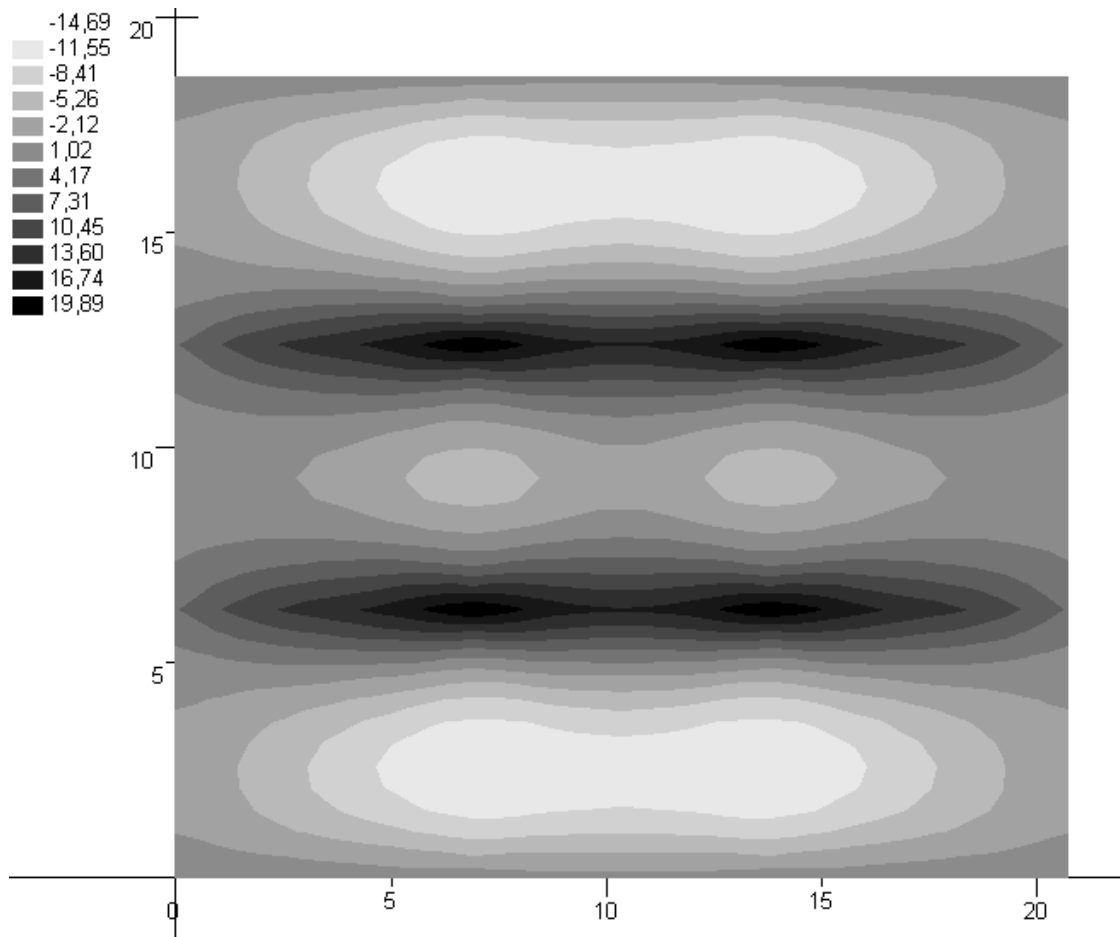

Slika 4.2. Momenti M_y (kNm)

4.1.2. Dodatno stalno opterećenje

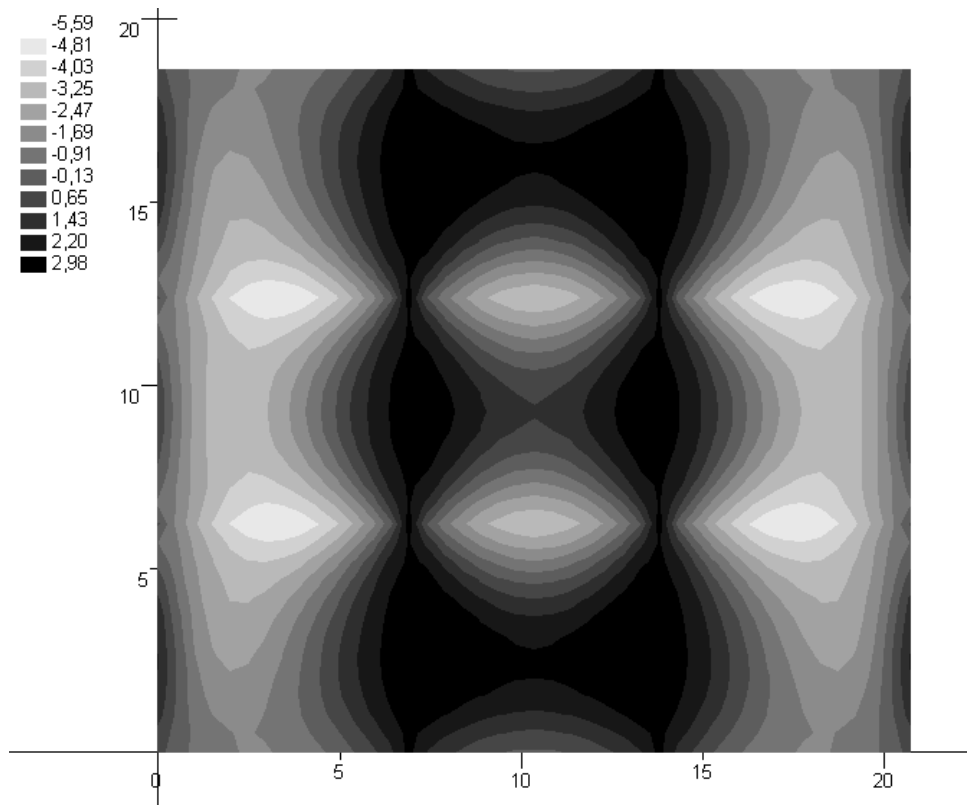

Slika 4.3. Momenti M_x (kNm)

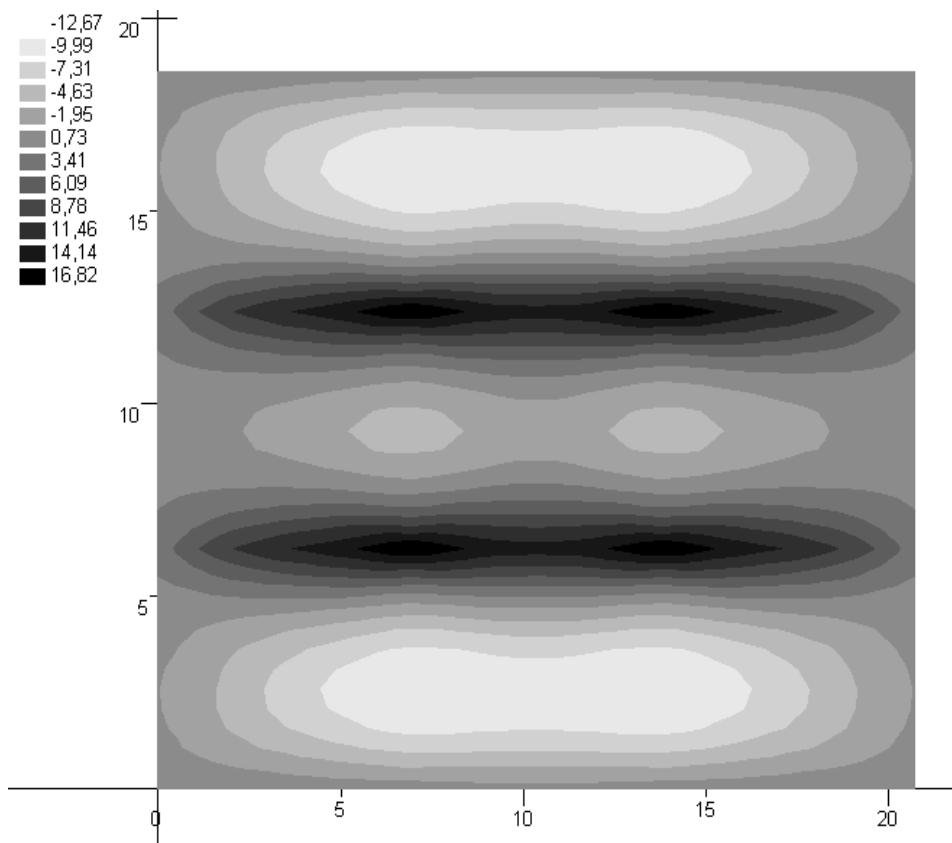

Slika 4.4. Momenti M_y (kNm)

4.1.3. Uporabnoopterećenje

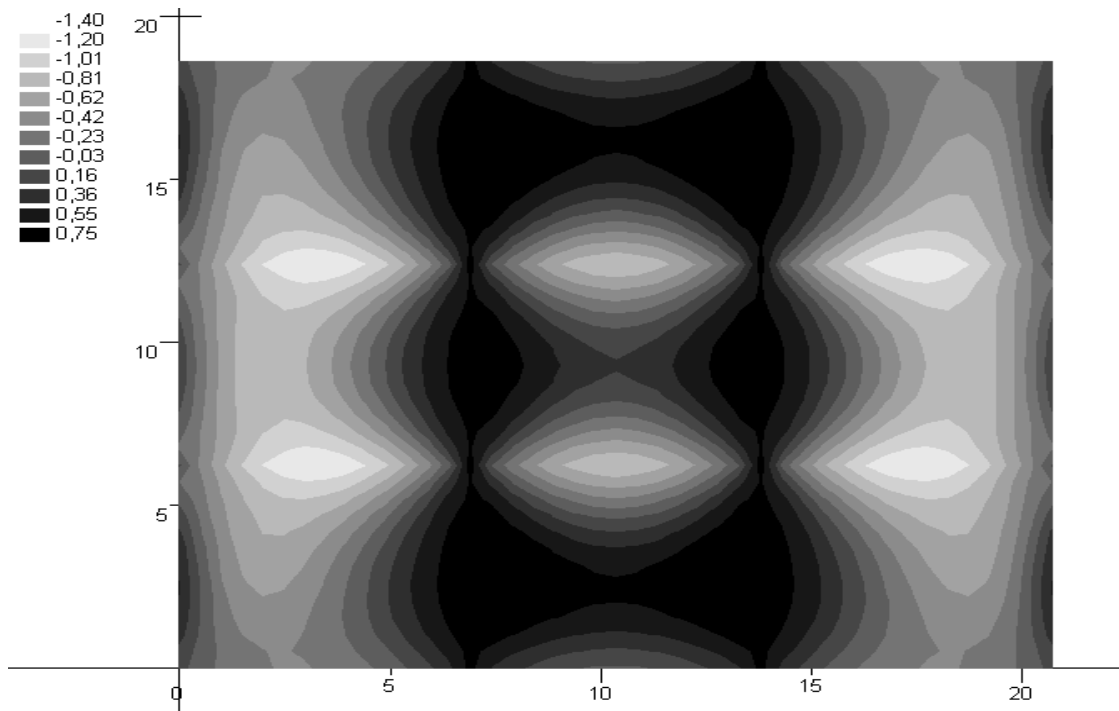

Slika 4.5. Momenti M_x (kNm)

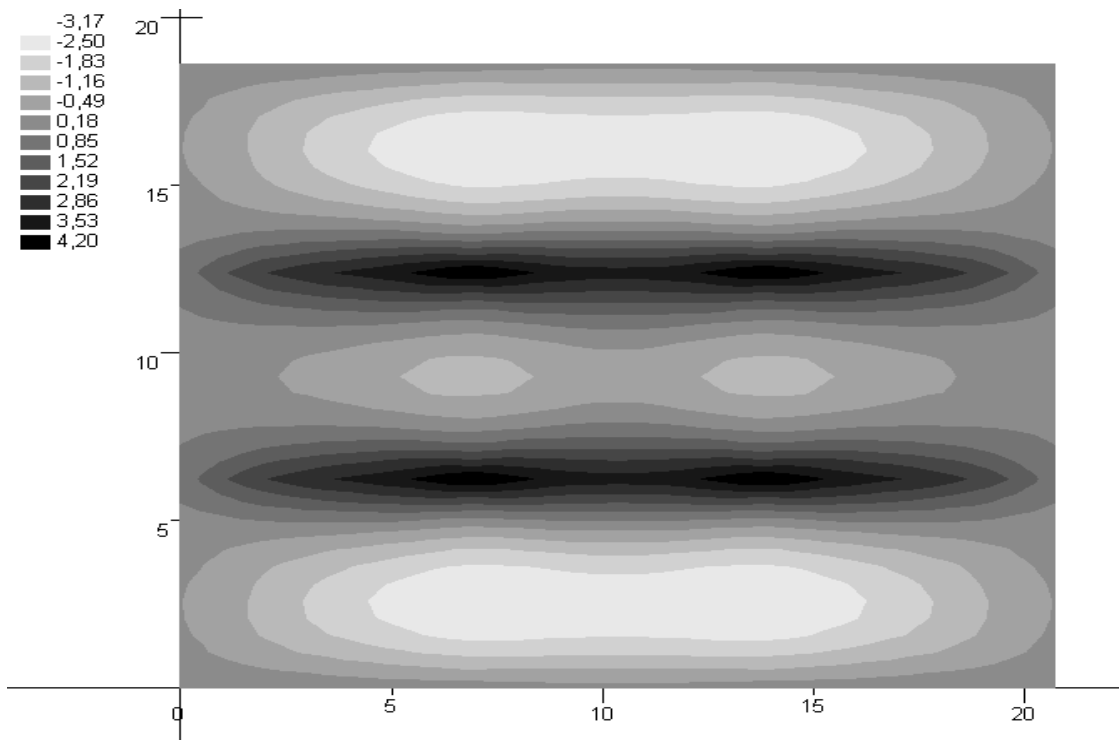

Slika 4.6. Momenti M_y (kNm)

4.1.4. Granično stanje nosivosti

Mjerodavna kombinacija: $M_{ed}=1,35*(M_g+M_{\Delta g})+1,5*M_q$

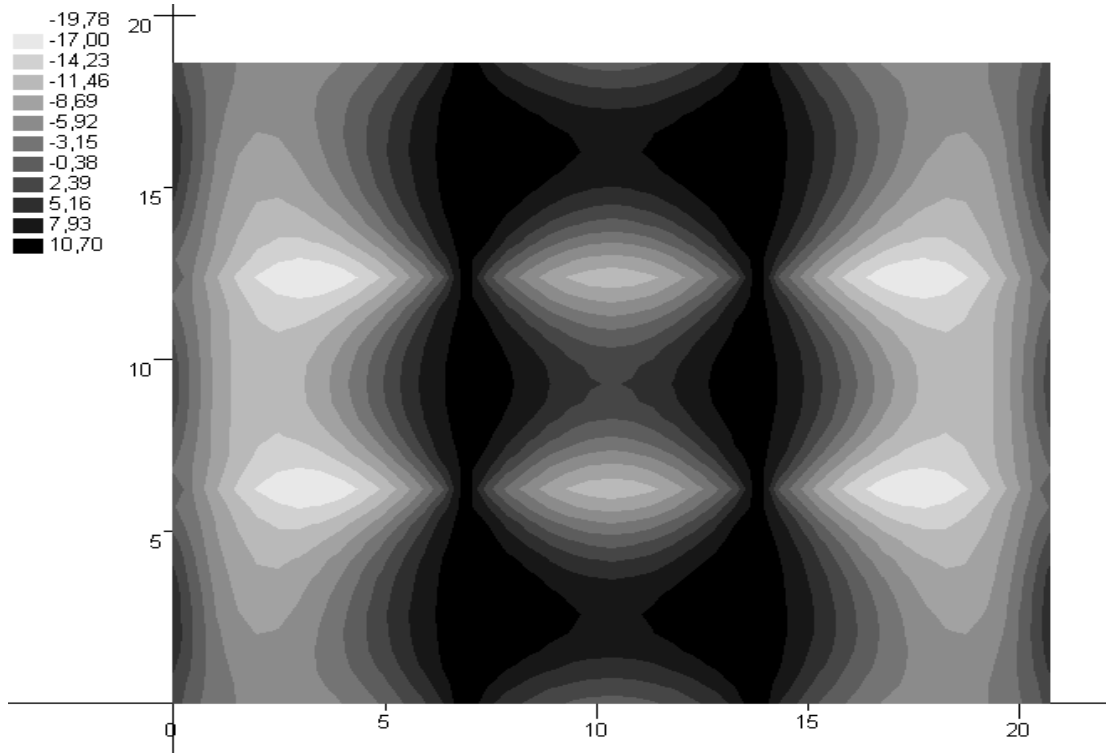

Slika 4.7. Momenti M_x (kNm)

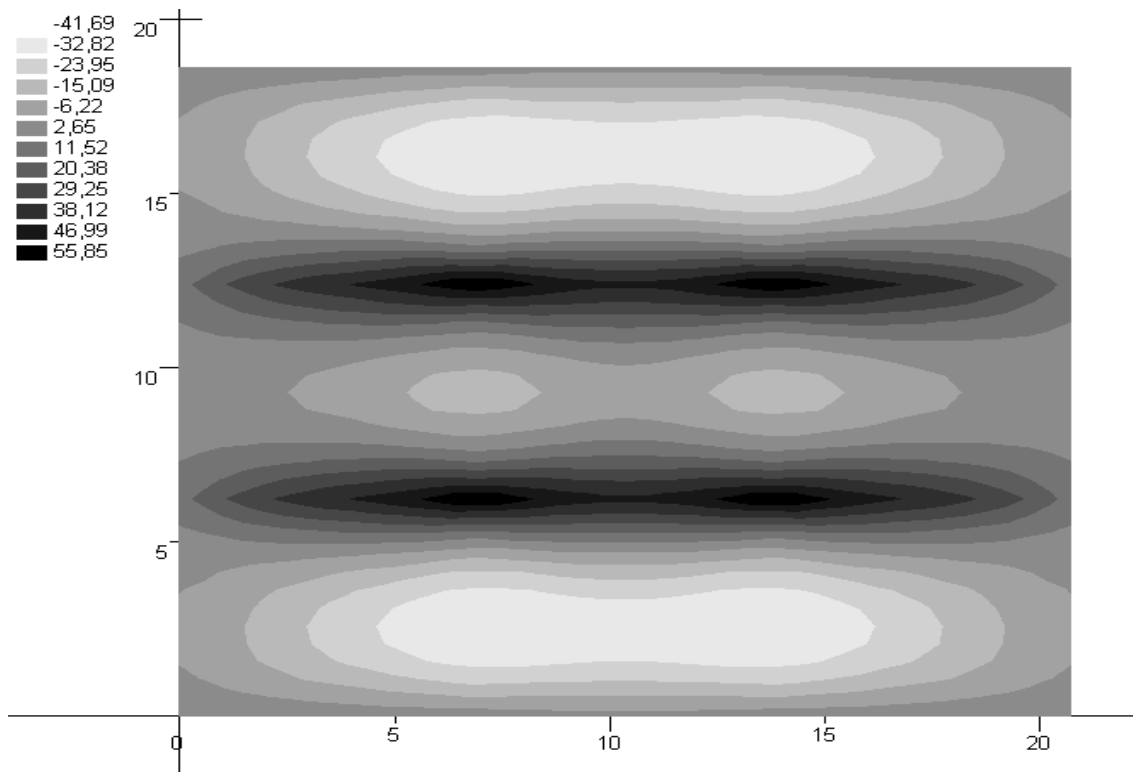

Slika 4.8. Momenti M_y (kNm)

4.2. DIMENZIONIRANJE PLOČA POZICIJE 200

BETON: C 40/50;

$$f_{ck} = 40,0 \text{ MPa} = 40 \text{ N/mm}^2 ; \gamma_c = 1,5$$

$$f_{cd} = f_{ck}/\gamma_c = 40,0/1,5 = 26,67 \text{ MPa} = 26,67 \text{ N/mm}^2 = 2,67 \text{ kN/cm}^2$$

ARMATURA: B 500 B;

$$f_{yk} = 500,0 \text{ MPa} = 500 \text{ N/mm}^2 ; \gamma_s = 1,15$$

$$f_{yd} = f_{yk}/\gamma_s = 500,0/1,15 = 434,78 \text{ MPa} = 434,78 \text{ N/mm}^2 = 43,48 \text{ kN/cm}^2$$

DEBLJINA PLOČE: $h = 18 \text{ cm}$

ZAŠTITNI SLOJ: $c = 3 \text{ cm}$

STATIČKA VISINA PLOČE:

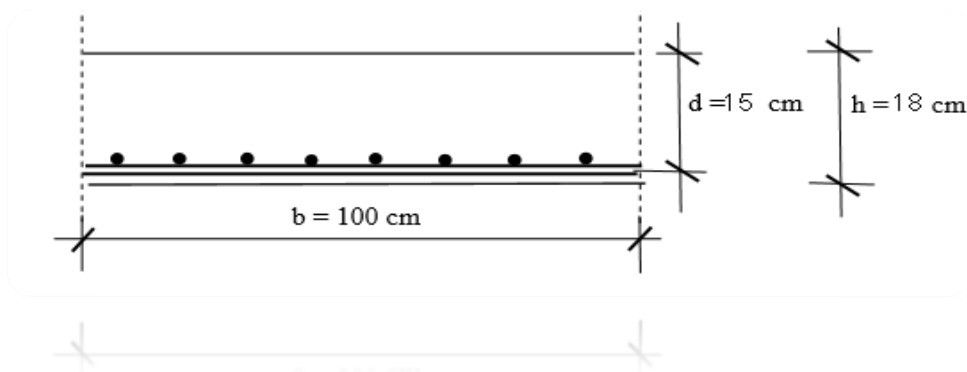

Slika 4.9. Poprečni presjek ploče

$$d = h - d_1$$

$$d_1 = c + \frac{\varnothing}{2} = 2,5 + 0,5 = 3 \text{ cm}$$

$c \rightarrow$ zaštitni sloj

STATIČKA VISINA PLOČE:

$$d = 18 - 3 = 15 \text{ cm}$$

Za sve presjeke odabrana je statička visina ploče $d = 15 \text{ cm}$. Izvršen je proračun armature za kombinaciju :

$$1,35 \times \text{vl.težina} + 1,35 \times \text{dodatno stalno} + 1,5 \times \text{uporabno}$$

Ploča 201 – Polje

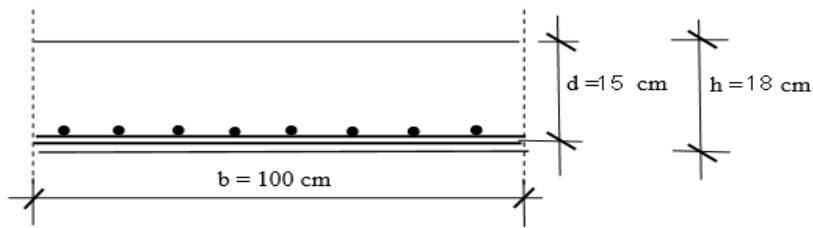

$$M_{ed} = 41,69 \text{ kNm/m}$$

$$\mu_{sd} = \frac{M_{ed}}{b_{eff} \cdot d^2 \cdot f_{cd}} = \frac{4169}{100 \cdot 15^2 \cdot 2,67} = 0,069$$

$$\text{Očitano: } \varepsilon_{s1} = 10,0 \text{ ‰} \quad \varepsilon_{c2} = 1,7 \text{ ‰} \quad \zeta = 0,947 \quad \xi = 0,145$$

$$A_{s1} = \frac{M_{ed}}{\zeta \cdot d \cdot f_{yd}} = \frac{4169}{0,947 \cdot 15 \cdot 43,48} = 6,75 \text{ cm}^2/\text{m}$$

ODABRANO: **R-785** ($A_s = 7,85 \text{ cm}^2/\text{m}$)

Ploča 202 - Polje

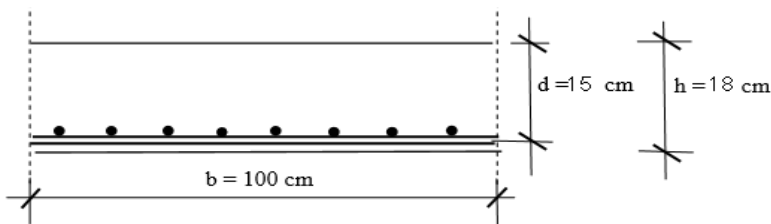

$$M_{ed} = 18,53 \text{ kNm/m}$$

$$\mu_{sd} = \frac{M_{ed}}{b_{eff} \cdot d^2 \cdot f_{cd}} = \frac{1853}{100 \cdot 15^2 \cdot 2,67} = 0,031$$

$$\text{Očitano: } \varepsilon_{s1} = 10,0 \text{ ‰} \quad \varepsilon_{c2} = 1,0 \text{ ‰} \quad \zeta = 0,968 \quad \xi = 0,091$$

$$A_{s1} = \frac{M_{ed}}{\zeta \cdot d \cdot f_{yd}} = \frac{1853}{0,968 \cdot 15 \cdot 43,48} = 2,94 \text{ cm}^2/\text{m}$$

ODABRANO: **R-385** ($A_s = 3,85 \text{ cm}^2/\text{m}$)

Ležaj 201-202

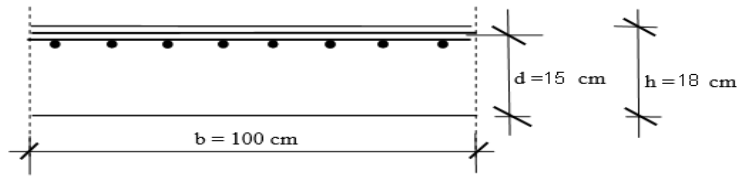

$$M_{ed} = 55,85 \text{ kNm/m}$$

$$\mu_{sd} = \frac{M_{ed}}{b_{eff} \cdot d^2 \cdot f_{cd}} = \frac{5585}{100 \cdot 15^2 \cdot 2,67} = 0,093$$

$$\text{Očitano: } \varepsilon_{s1} = 10,0 \text{ ‰} \quad \varepsilon_{c2} = 2,1 \text{ ‰} \quad \zeta = 0,934 \quad \xi = 0,174$$

$$A_{s1} = \frac{M_{ed}}{\zeta \cdot d \cdot f_{yd}} = \frac{5585}{0,934 \cdot 15 \cdot 43,48} = 9,17 \text{ cm}^2/\text{m}$$

ODABRANO: **R-785** ($A_s = 7,85 \text{ cm}^2/\text{m}$) + preklop povečan na 40 cm

$$A'_{s1} = A_{s1} \cdot \frac{\xi_m + p_m}{\xi_m} = 7,85 \cdot \frac{215 + 40}{215} = 9,31 \text{ cm}^2/\text{m}$$

Minimalna armatura:

$$A_{s1, \min} \geq 0,26 \cdot [f_{ct,m} / f_{yk}] \cdot b_t \cdot d \geq 0,0013 \cdot b_t \cdot d$$

b_t – širina vlačne zone

d – statička visina presjeka

f_{yk} – karakt. granica popuštanja čelika u N/mm²

[$f_{yk} = 500 \text{ N/mm}^2$ za čelik B 500B]

$f_{ct,m}$ - srednja vlačna čvrstoća betona (iz tablice)

[$f_{ctm} = 356 \text{ N/mm}^2$ za C 40/50]

$$A_{s1, \min} \geq 0,26 \cdot 3,5 / 500 \cdot 100 \cdot 15,0 = 2,73 \text{ cm}^2 / \text{m}$$

$$A_{s1, \min} \geq 0,0013 \cdot b_t \cdot d = 0,0013 \cdot 100 \cdot 15,0 = 1,95 \text{ cm}^2 / \text{m}$$

5. PRORAČUN PLOČA POZICIJE 100

5.1. MOMENTI SAVIJANJA U PLOČI POZICIJE 100

5.1.1. Vlastita težina

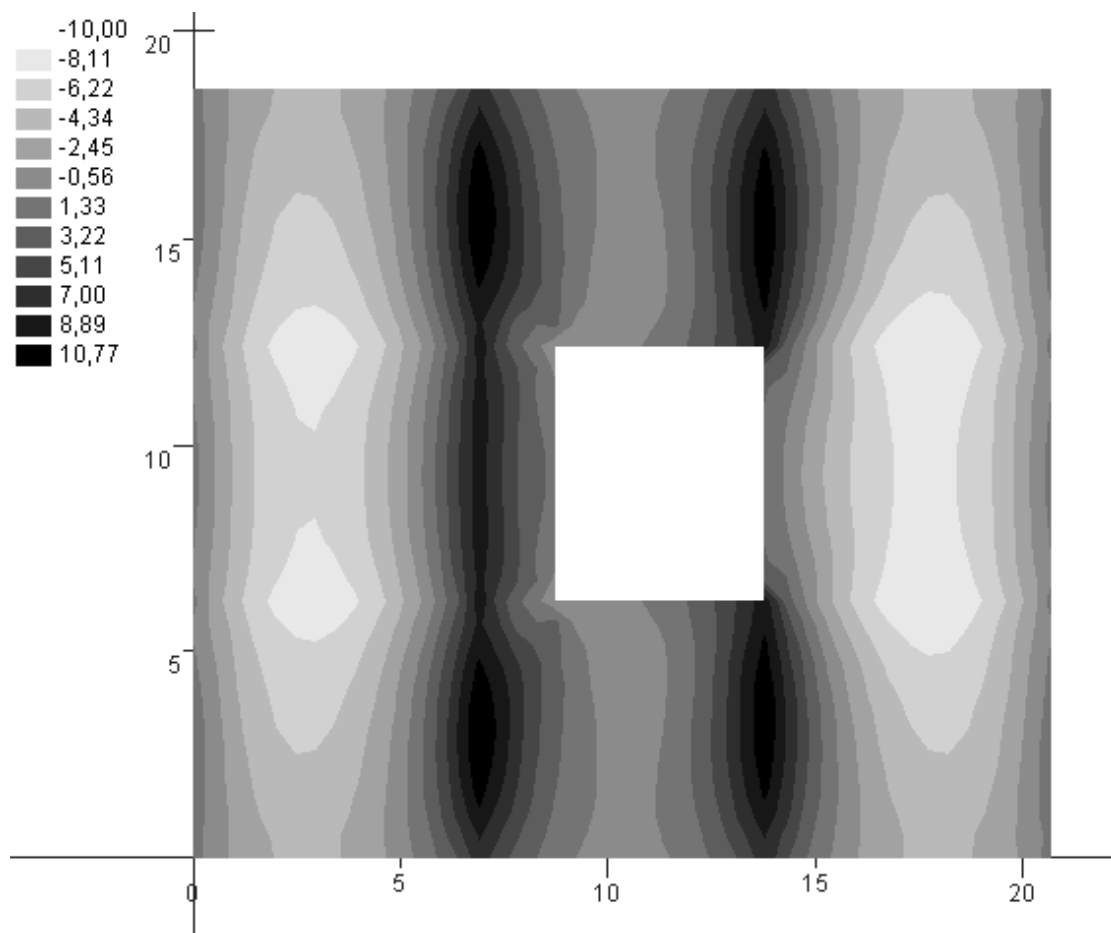

Slika 5.1. Momenti M_x (kNm)

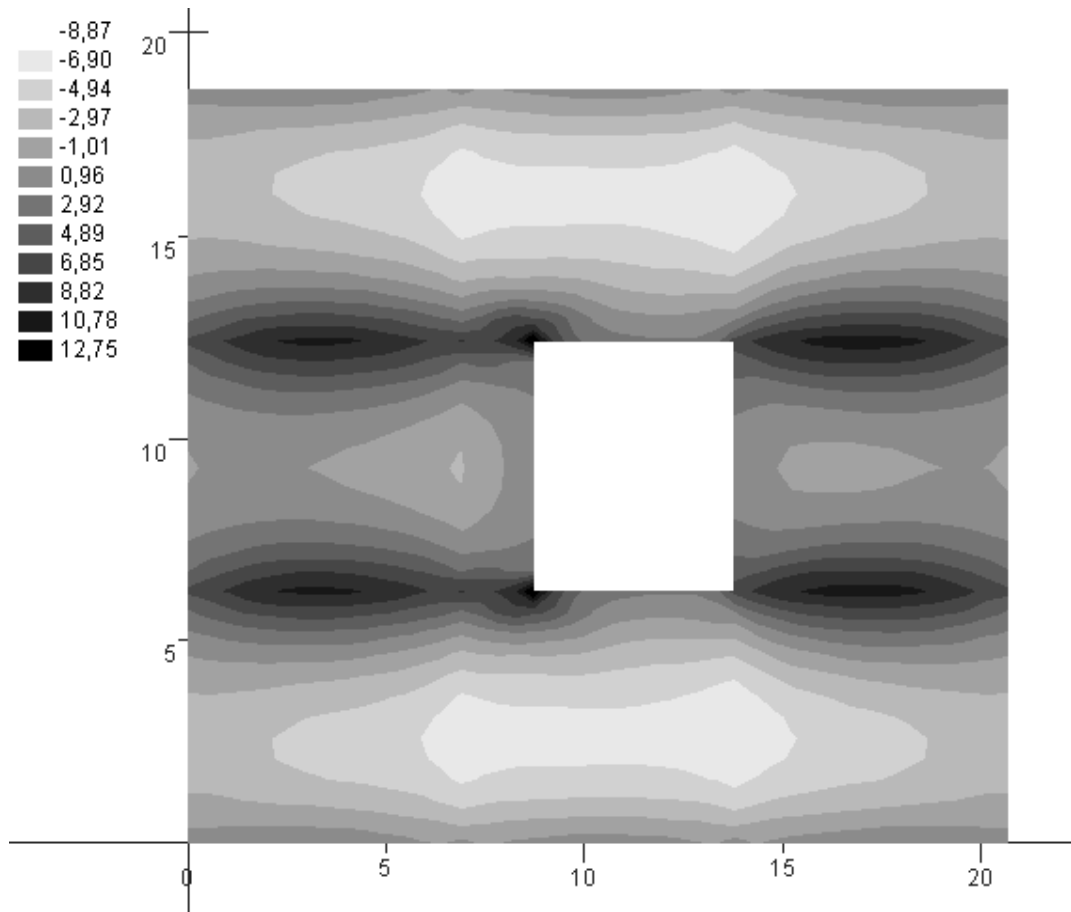

Slika 5.2. Momenti M_y (kNm)

5.1.2. Dodatno stalno opterećenje

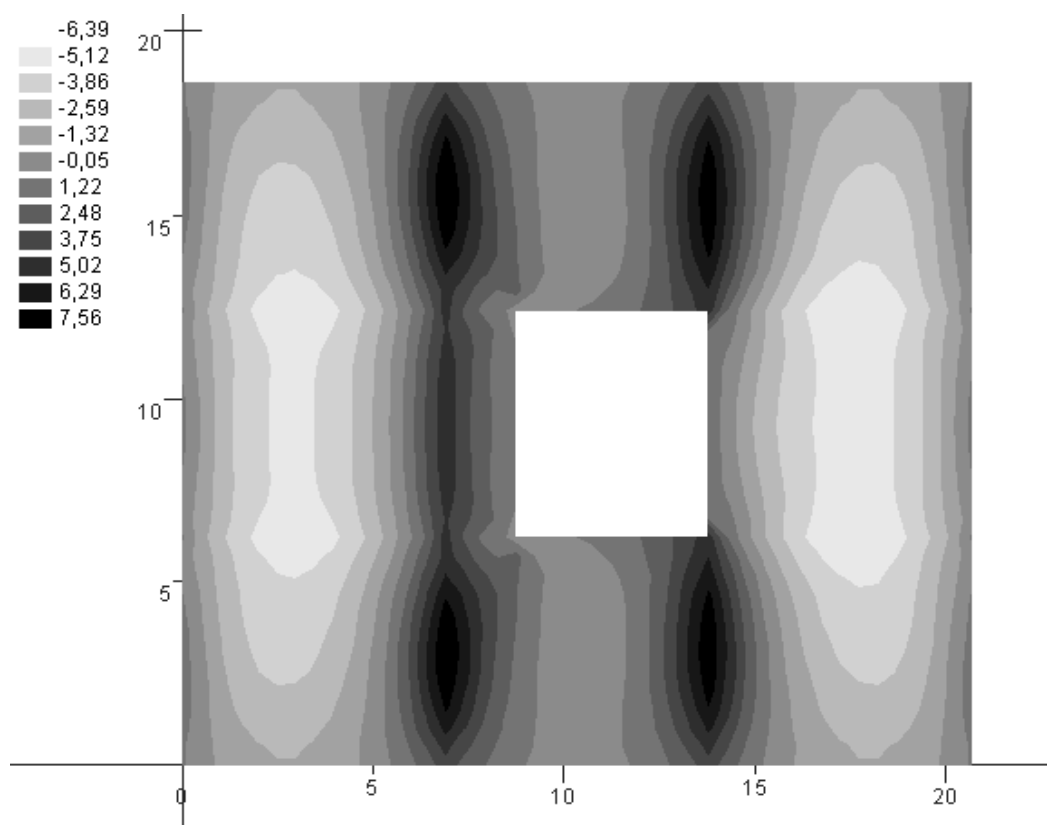

Slika 5.3. Momenti M_x (kNm)

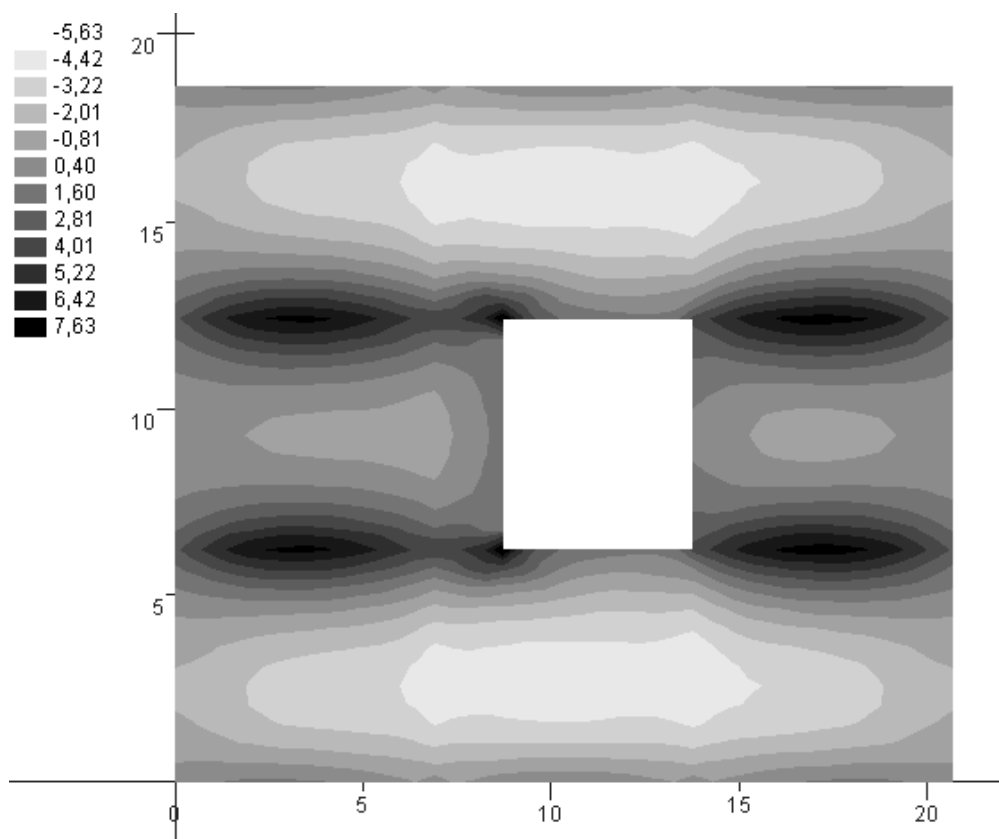

Slika 5.4. Momenti M_y (kNm)

5.1.3. Uporabno opterečenje shema 1 (max momenti na ležajevima)

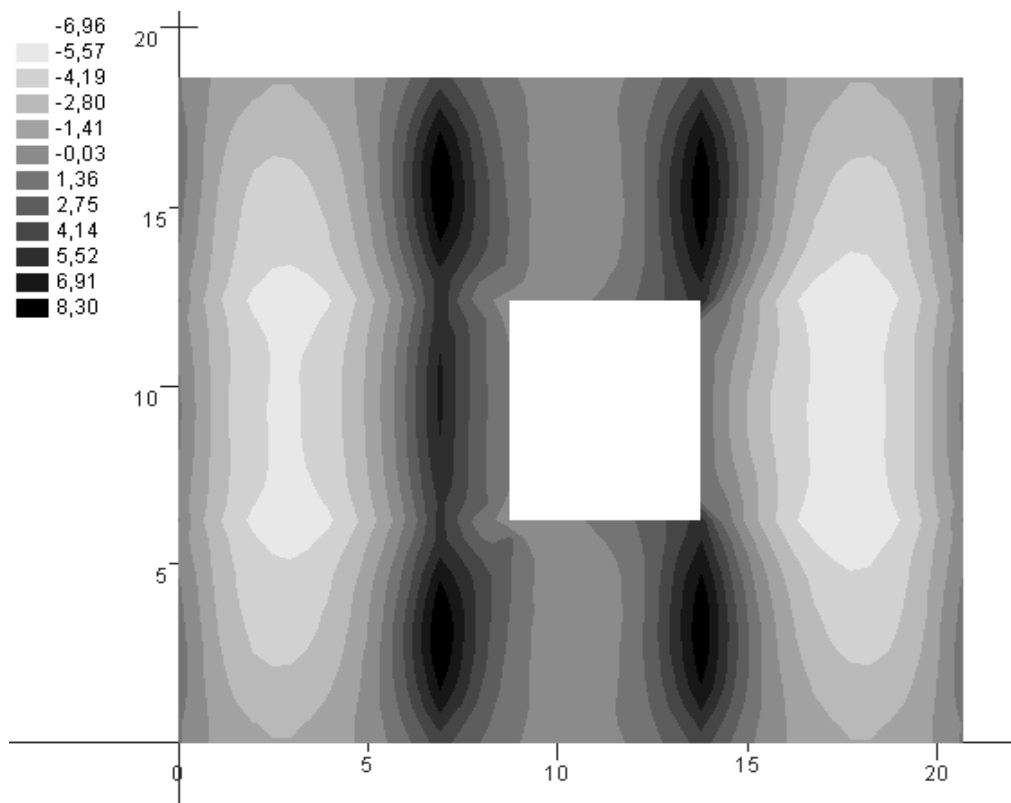

Slika 5.5. Momenti M_x (kNm)

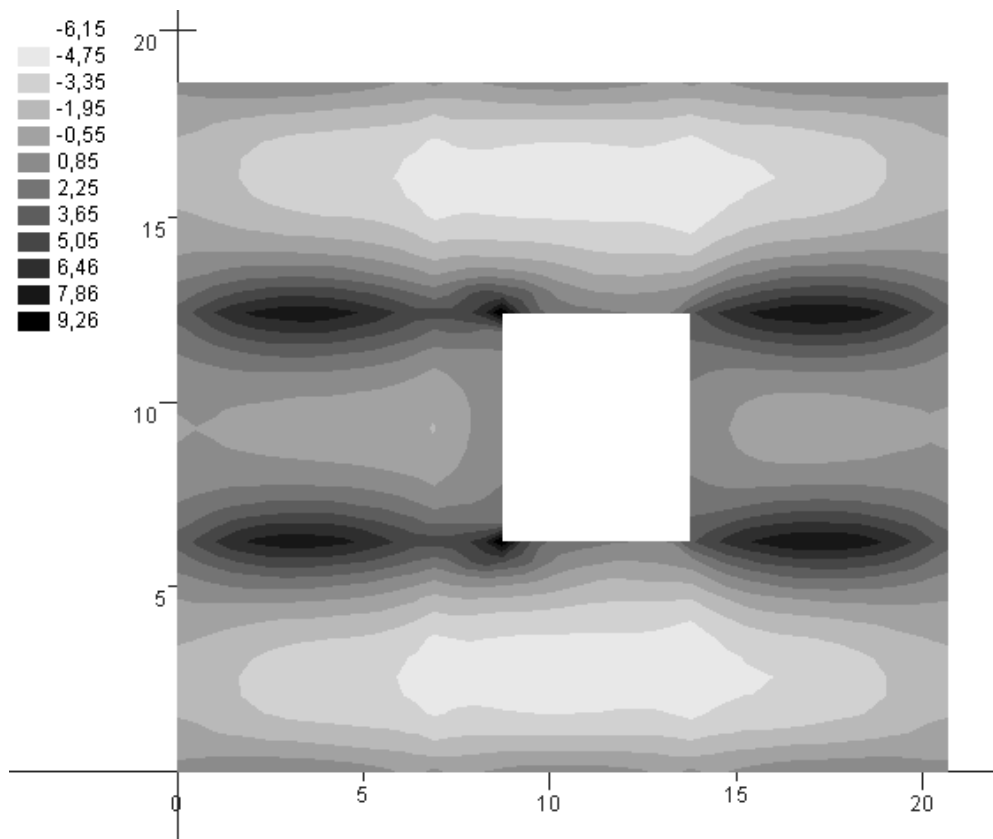

Slika 5.6. Momenti M_y (kNm)

5.1.4. Uporabno-opterečenje shema 2(max momenti u krajnjim poljima)

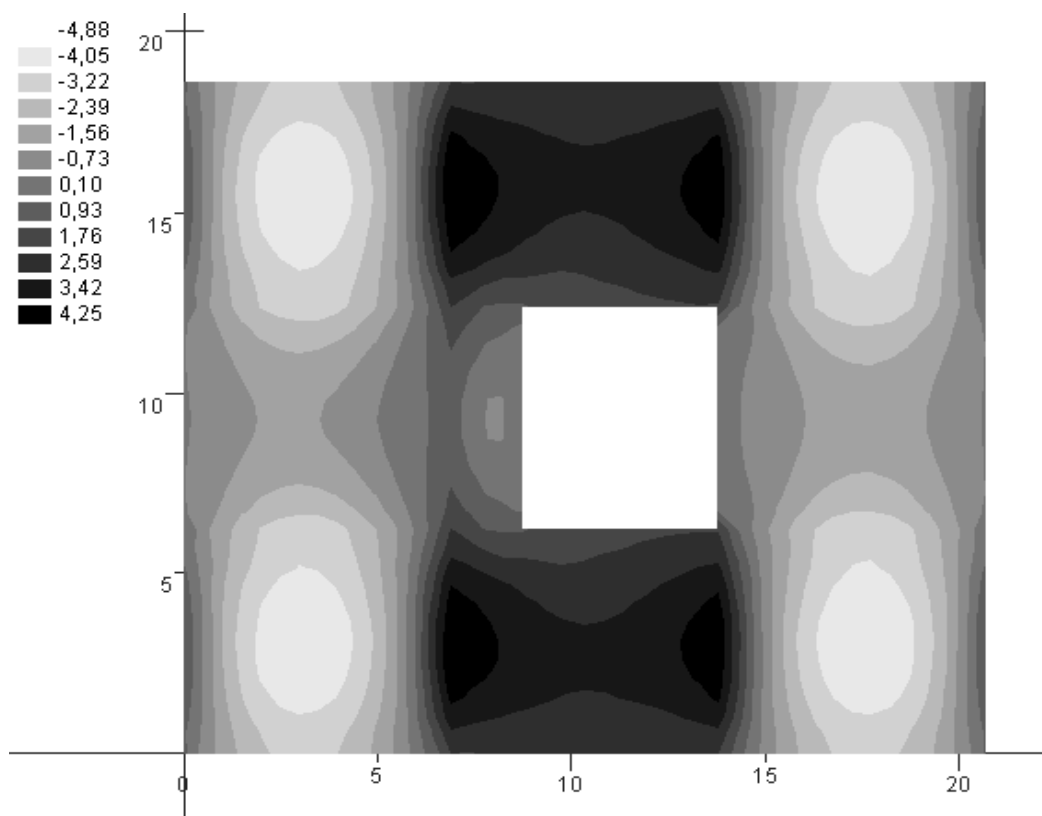

Slika 5.7. Momenti M_x (kNm)

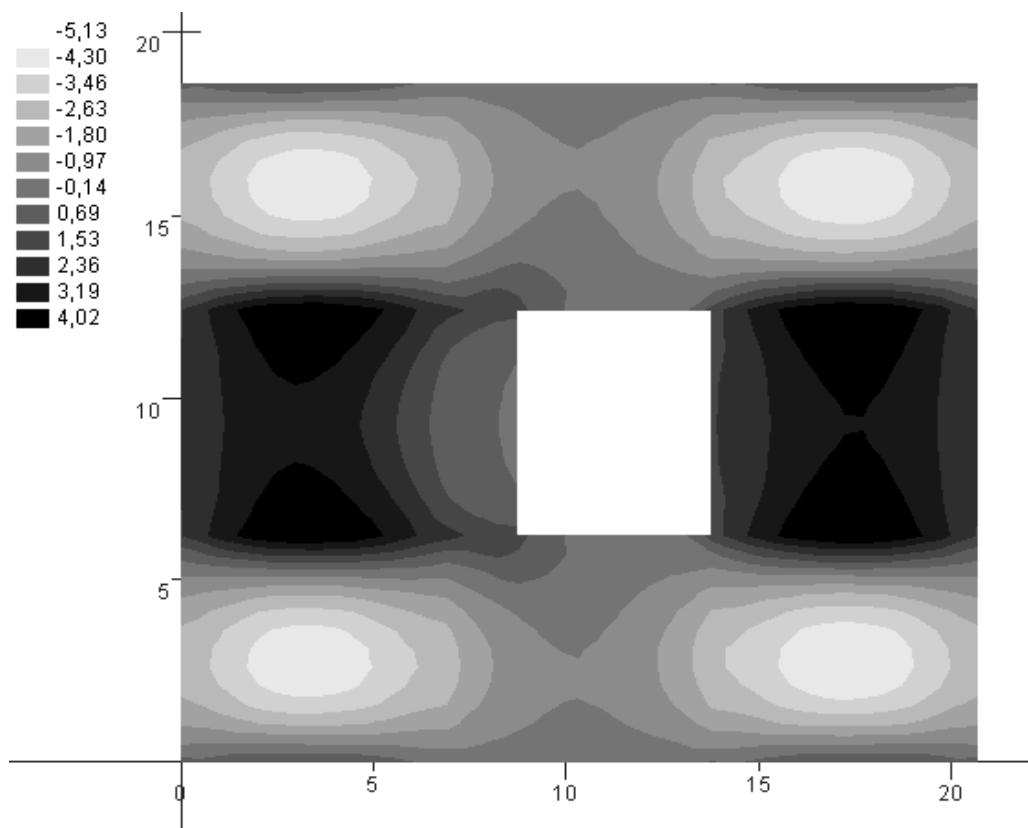

Slika 5.8. Momenti M_y (kNm)

5.1.5. Uporabnoopterećenje shema 3 (max momenti u srednjem polju)

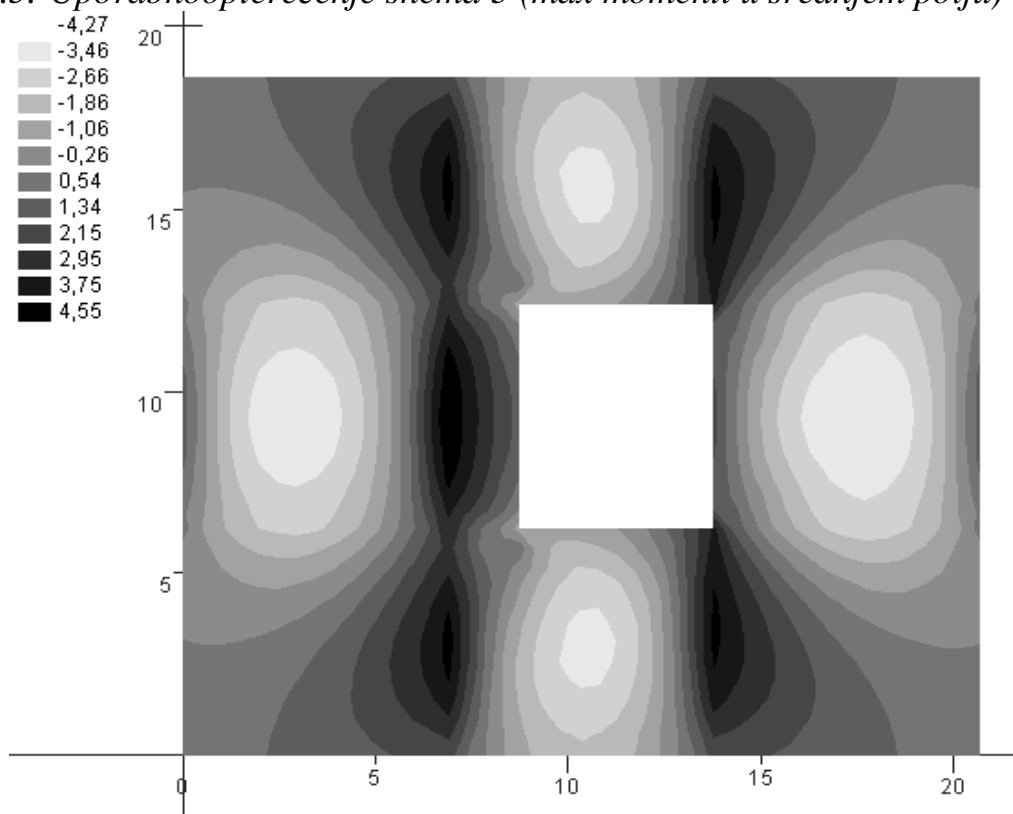

Slika 5.9. Momenti M_x (kNm)

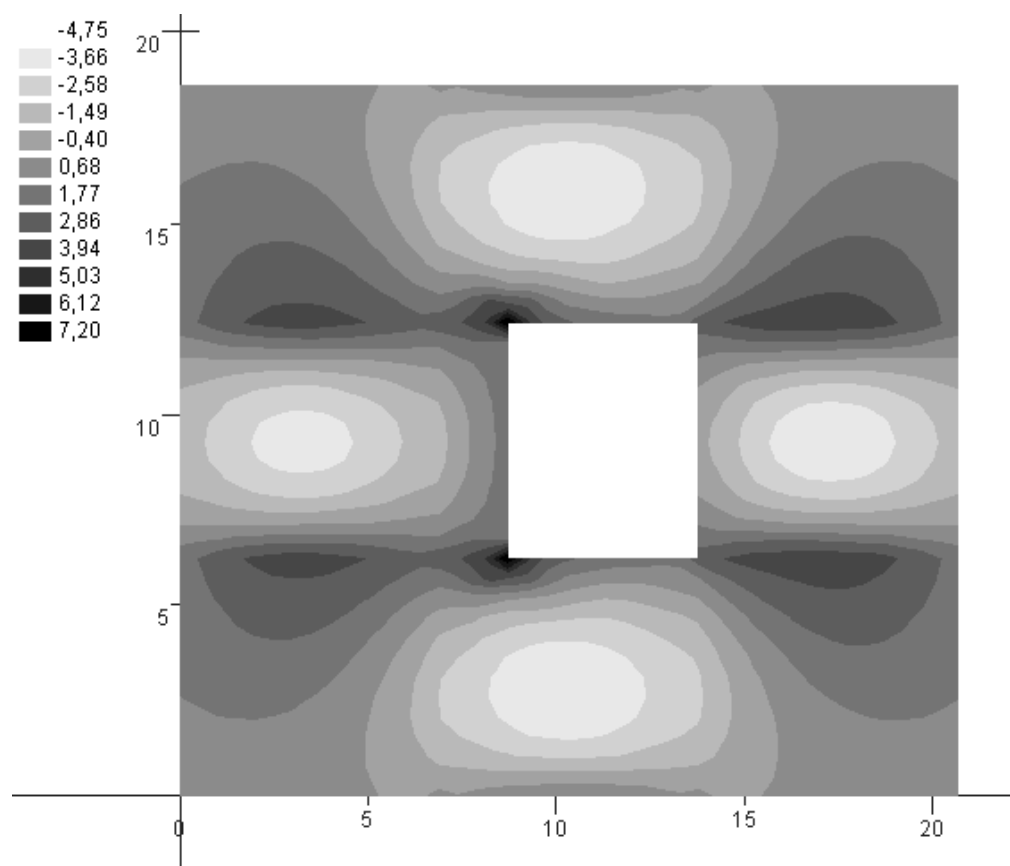

Slika 5.10. Momenti M_y (kNm)

5.1.6. GSN za ležajeve

Mjerodavna kombinacija za proračun GSN: $M_{ed}=1,35*(M_g+M_{\Delta g})+1,5*M_q$

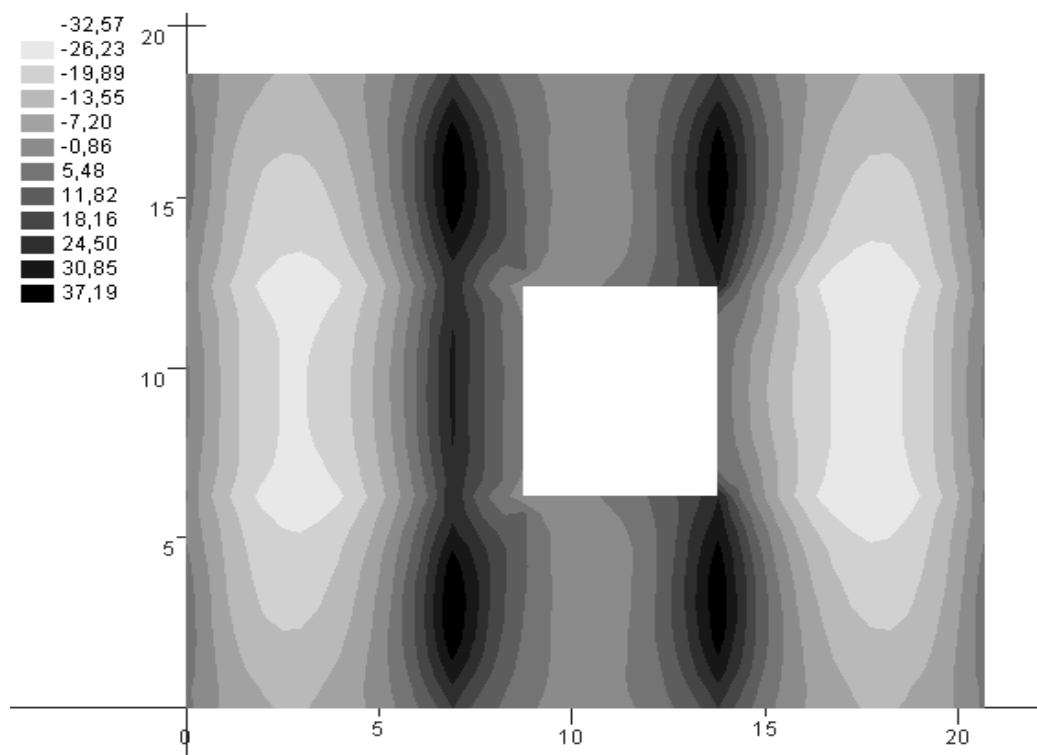

Slika 5.11. Momenti M_x (kNm)

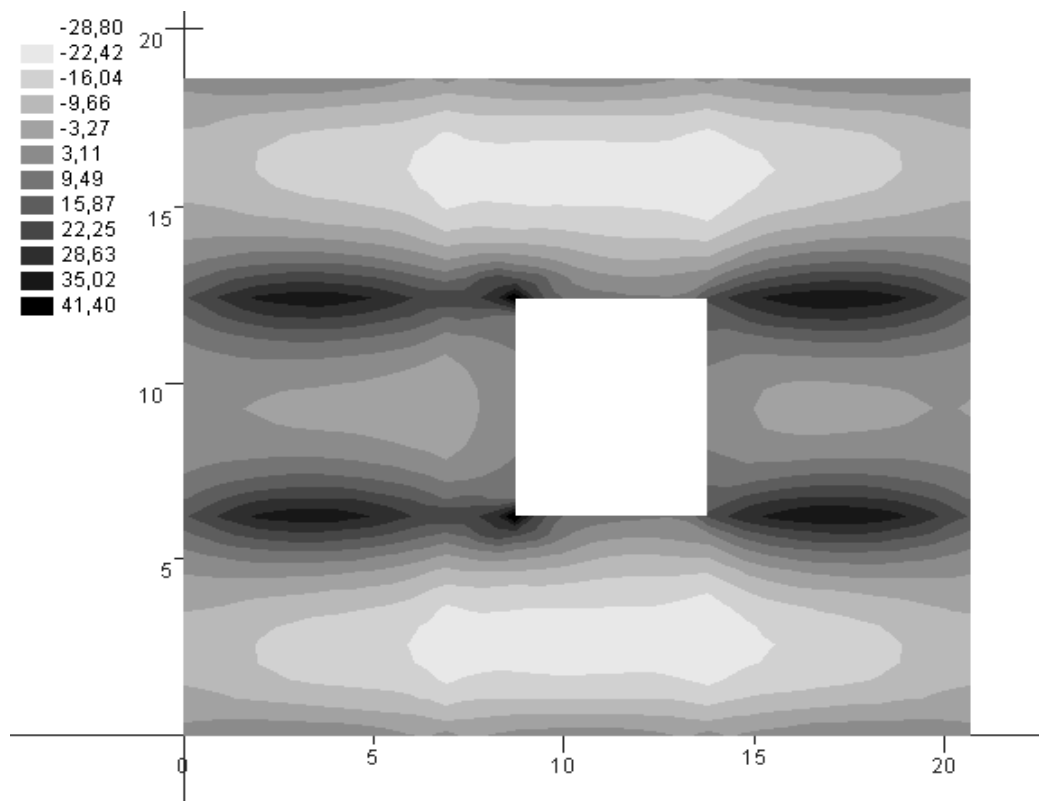

Slika 5.12. Momenti M_y (kNm)

5.1.7. GSN za krajnja polja

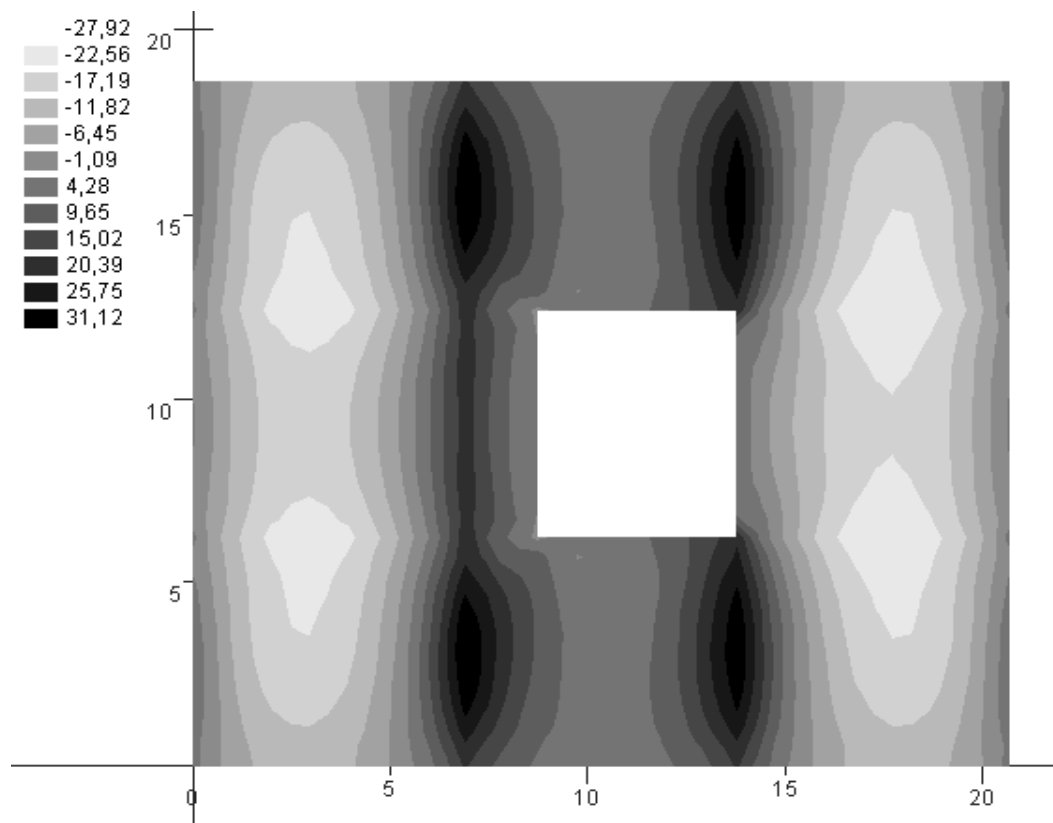

Slika 5.13. Momenti M_x (kNm)

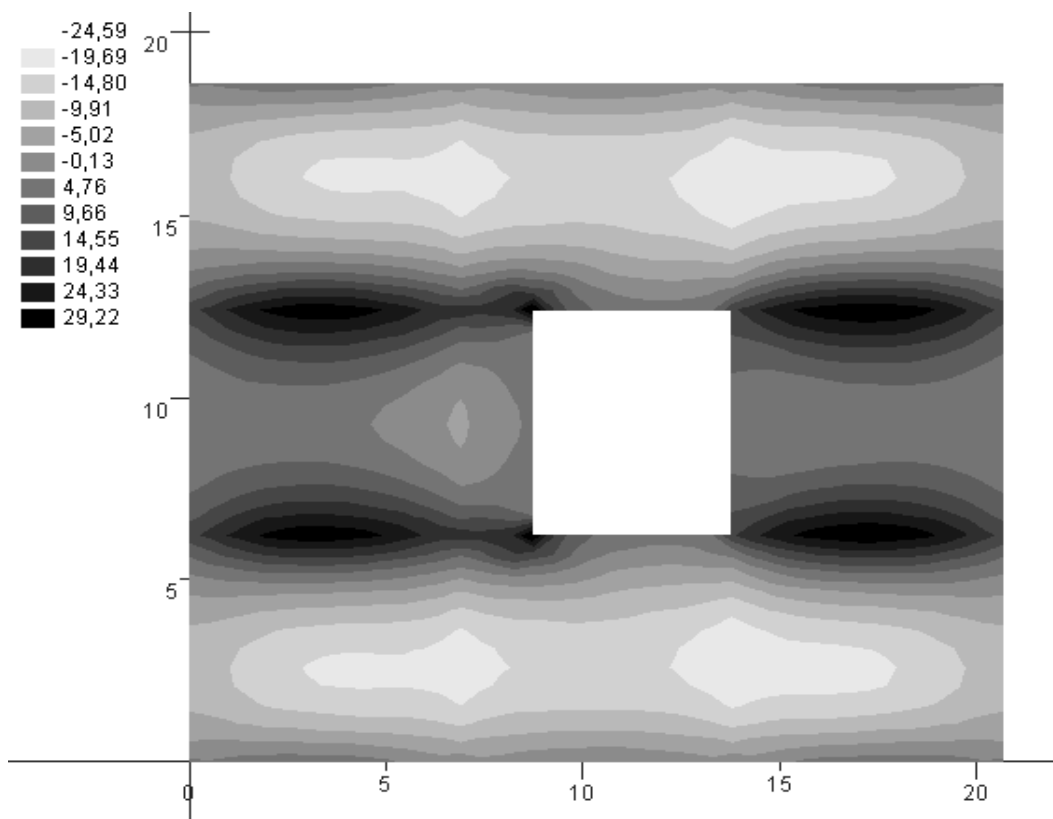

Slika 5.14. Momenti M_y (kNm)

5.1.8. GSN za srednje polje

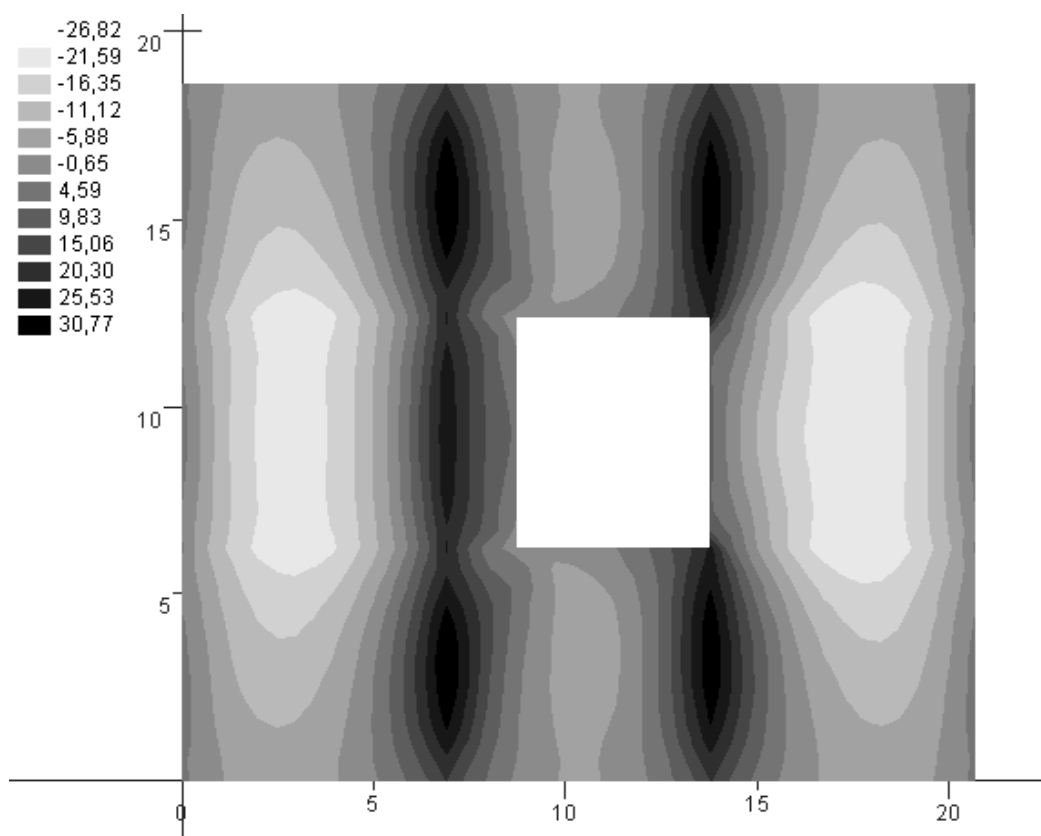

Slika 5.15. Momenti M_x (kNm)

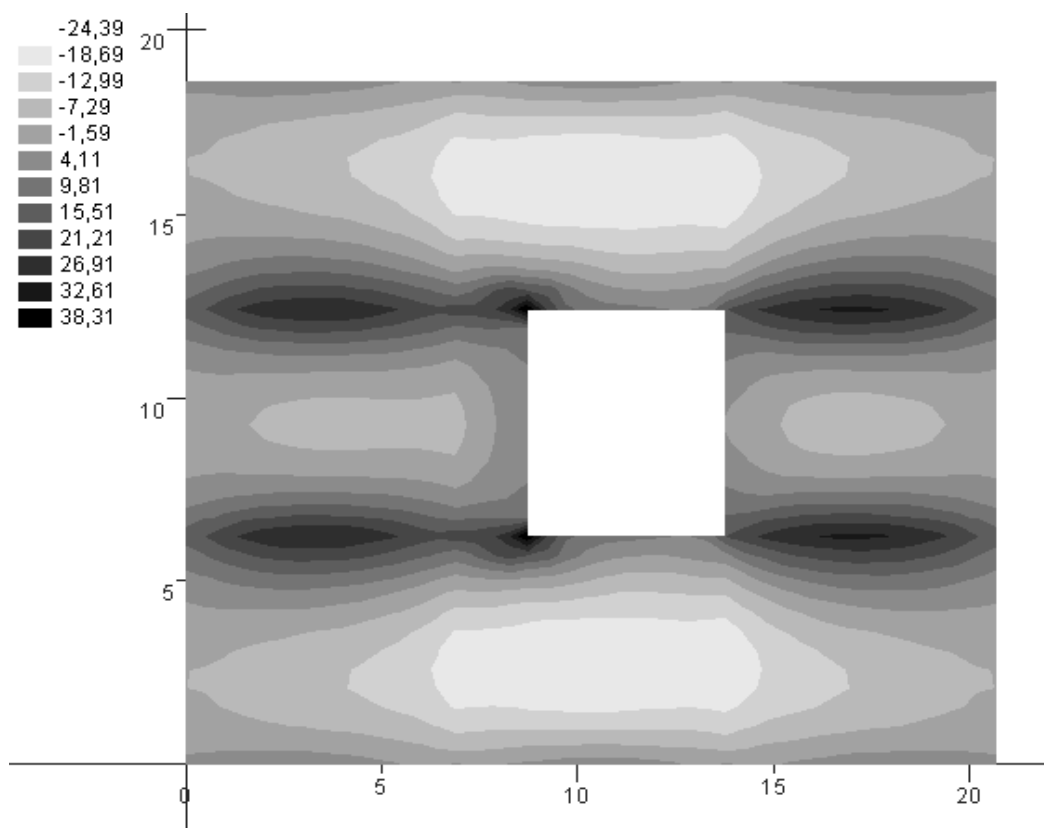

Slika 5.16. Momenti M_y (kNm)

5.2. DIMENZIONIRANJE PLOČA POZICIJE 100

BETON: C 40/50;

$$f_{ck} = 40,0 \text{ MPa} = 40 \text{ N/mm}^2 ; \gamma_c = 1,5$$

$$f_{cd} = f_{ck} / \gamma_c = 40,0 / 1,5 = 26,67 \text{ MPa} = 26,67 \text{ N/mm}^2 = 2,67 \text{ kN/cm}^2$$

ARMATURA: B 500 B;

$$f_{yk} = 500,0 \text{ MPa} = 500 \text{ N/mm}^2 ; \gamma_s = 1,15$$

$$f_{yd} = f_{yk} / \gamma_s = 500,0 / 1,15 = 434,78 \text{ MPa} = 434,78 \text{ N/mm}^2 = 43,48 \text{ kN/cm}^2$$

Ploča 101 – polje

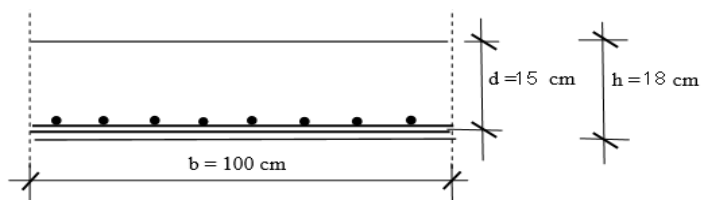

$$M_{Ed} = 27,92 \text{ kNm/m}$$

$$\mu_{sd} = \frac{M_{Ed}}{b \cdot d^2 \cdot f_{cd}} = \frac{2792}{100 \cdot 15^2 \cdot 2,67} = 0,046$$

Očitano: $\varepsilon_{s1} = 10,0 \text{ ‰}$ $\varepsilon_{c2} = 1,3 \text{ ‰}$ $\xi = 0,115$ $\zeta = 0,959$

$$A_{s1} = \frac{M_{Ed}}{\zeta \cdot d \cdot f_{yd}} = \frac{2792}{0,959 \cdot 15 \cdot 43,48} = 4,46 \text{ cm}^2/\text{m}$$

Ploča 102 – polje

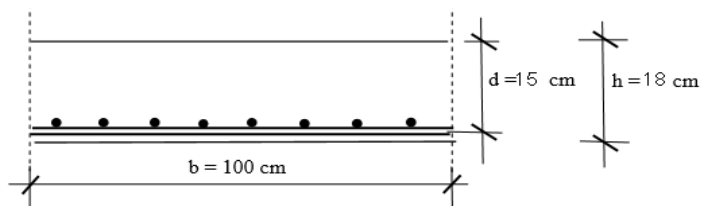

$$M_{Ed} = 24,39 \text{ kNm/m}$$

$$\mu_{sd} = \frac{M_{Ed}}{b \cdot d^2 \cdot f_{cd}} = \frac{2439}{100 \cdot 15^2 \cdot 2,67} = 0,041$$

Očitano: $\varepsilon_{s1} = 10,0 \text{ ‰}$ $\varepsilon_{c2} = 1,2 \text{ ‰}$ $\xi = 0,107$ $\zeta = 0,962$

$$A_{s1} = \frac{M_{Ed}}{\zeta \cdot d \cdot f_{yd}} = \frac{2439}{0,962 \cdot 15 \cdot 43,48} = 3,89 \text{ cm}^2/\text{m}$$

Ploča 103 – polje

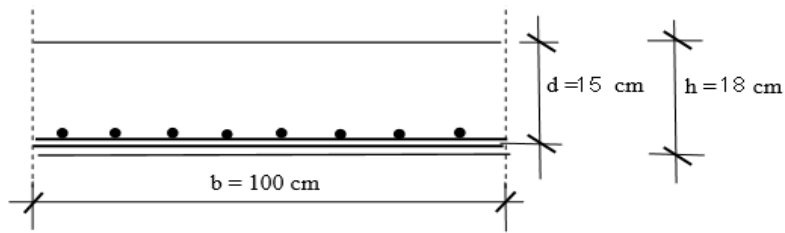

$$M_{Ed} = 26.82 \text{ kNm/m}$$

$$\mu_{sd} = \frac{M_{Ed}}{b \cdot d^2 \cdot f_{cd}} = \frac{2682}{100 \cdot 15^2 \cdot 2.67} = 0.045$$

$$\text{Očitano: } \varepsilon_{s1} = 10.0 \text{ ‰} \quad \varepsilon_{c2} = 1.3 \text{ ‰} \quad \xi = 0.115 \quad \zeta = 0.959$$

$$A_{s1} = \frac{M_{Ed}}{\zeta \cdot d \cdot f_{yd}} = \frac{2682}{0.959 \cdot 15 \cdot 43.48} = 4.30 \text{ cm}^2/\text{m}$$

Ploča 104 – polje

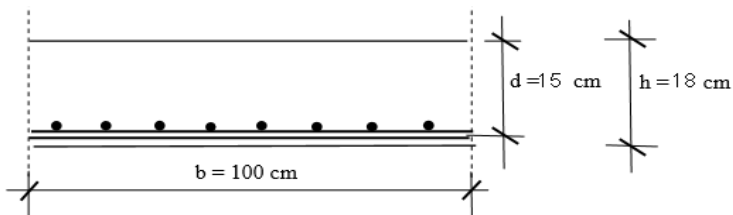

$$M_{Ed} = 16.84 \text{ kNm/m}$$

$$\mu_{sd} = \frac{M_{Ed}}{b \cdot d^2 \cdot f_{cd}} = \frac{1684}{100 \cdot 15^2 \cdot 2.67} = 0.028$$

$$\text{Očitano: } \varepsilon_{s1} = 10.0 \text{ ‰} \quad \varepsilon_{c2} = 1.0 \text{ ‰} \quad \xi = 0.091 \quad \zeta = 0.968$$

$$A_{s1} = \frac{M_{Ed}}{\zeta \cdot d \cdot f_{yd}} = \frac{1684}{0.968 \cdot 15 \cdot 43.48} = 2.67 \text{ cm}^2/\text{m}$$

Odabrano za sve ploče: Q-503 (5,03 cm²/m)

Ležaj 101 – 102

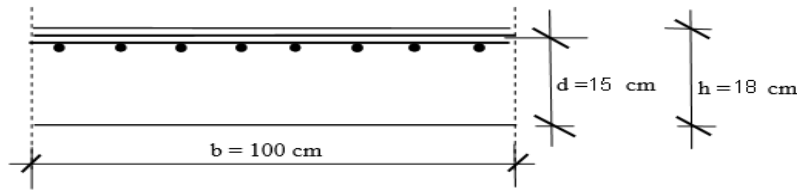

$$M_{Ed} = 37.19 \text{ kNm/m}$$

$$\mu_{sd} = \frac{M_{Ed}}{b \cdot d^2 \cdot f_{cd}} = \frac{3719}{100 \cdot 15^2 \cdot 2.67} = 0.062$$

$$\text{Očitano: } \varepsilon_{s1} = 10.0\text{‰} \quad \varepsilon_{c2} = 1.6\text{‰} \quad \xi = 0.138 \quad \zeta = 0.950$$

$$A_{s1} = \frac{M_{Ed}}{\zeta \cdot d \cdot f_{yd}} = \frac{3719}{0.950 \cdot 15 \cdot 43.48} = 6.00 \text{ cm}^2/\text{m}$$

Ležaj 101 – 103

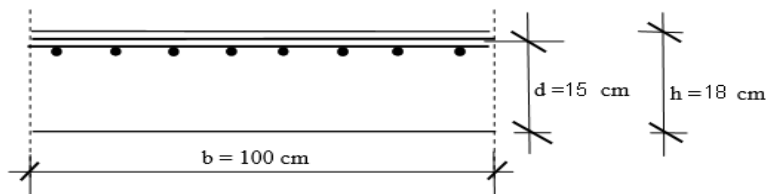

$$M_{Ed} = 41.40 \text{ kNm/m}$$

$$\mu_{sd} = \frac{M_{Ed}}{b \cdot d^2 \cdot f_{cd}} = \frac{4140}{100 \cdot 15^2 \cdot 2.67} = 0.069$$

$$\text{Očitano: } \varepsilon_{s1} = 10.0\text{‰} \quad \varepsilon_{c2} = 1.7\text{‰} \quad \xi = 0.145 \quad \zeta = 0.947$$

$$A_{s1} = \frac{M_{Ed}}{\zeta \cdot d \cdot f_{yd}} = \frac{4140}{0.947 \cdot 15 \cdot 43.48} = 6.7 \text{ cm}^2/\text{m}$$

Ležaj 103 – 104

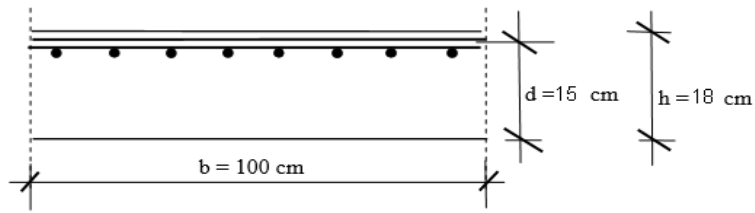

$$M_{Ed} = 29.44 \text{ kNm/m}$$

$$\mu_{sd} = \frac{M_{Ed}}{b \cdot d^2 \cdot f_{cd}} = \frac{2944}{100 \cdot 15^2 \cdot 2.67} = 0.049$$

$$\text{Očitano: } \varepsilon_{s1} = 10.0\% \quad \varepsilon_{c2} = 1.4\% \quad \xi = 0.123 \quad \zeta = 0.956$$

$$A_{s1} = \frac{M_{Ed}}{\zeta \cdot d \cdot f_{yd}} = \frac{2944}{0.956 \cdot 15 \cdot 43.48} = 4.72 \text{ cm}^2/\text{m}$$

Odabrana mreža za sve ležaje: R-785 ($A_s = 7,85 \text{ cm}^2/\text{m}$)

Minimalna armatura:

$$A_{s1, \min} \geq 0,26 \cdot [f_{ct,m} / f_{yk}] \cdot b \cdot t \cdot d \geq 0,0013 \cdot b \cdot t \cdot d$$

b t – širina vlačne zone

d – statička visina presjeka

f_{yk} – karakt. granica popuštanja čelika u N/mm²

[f_{yk} = 500 N/mm² za čelik B 500B]

f_{ct,m} - srednja vlačna čvrstoća betona (iz tablice)

[f_{ct,m} = 3.5 N/mm² za C 40/50]

$$A_{s1, \min} \geq 0,26 \cdot 3.5 / 500 \cdot 100 \cdot 15,0 = 2.73 \text{ cm}^2 / \text{m}$$

$$A_{s1, \min} \geq 0,0013 \cdot b \cdot t \cdot d = 0,0013 \cdot 100 \cdot 15,0 = 1,95 \text{ cm}^2 / \text{m}$$

6. PRORAČUN KONTINUIRANOG NOSAČA POZICIJE 200

6.1. MOMENTI SAVIJANJA I POPREČNE SILE GREDE POZICIJE 200

6.1.1. Vlastita težina

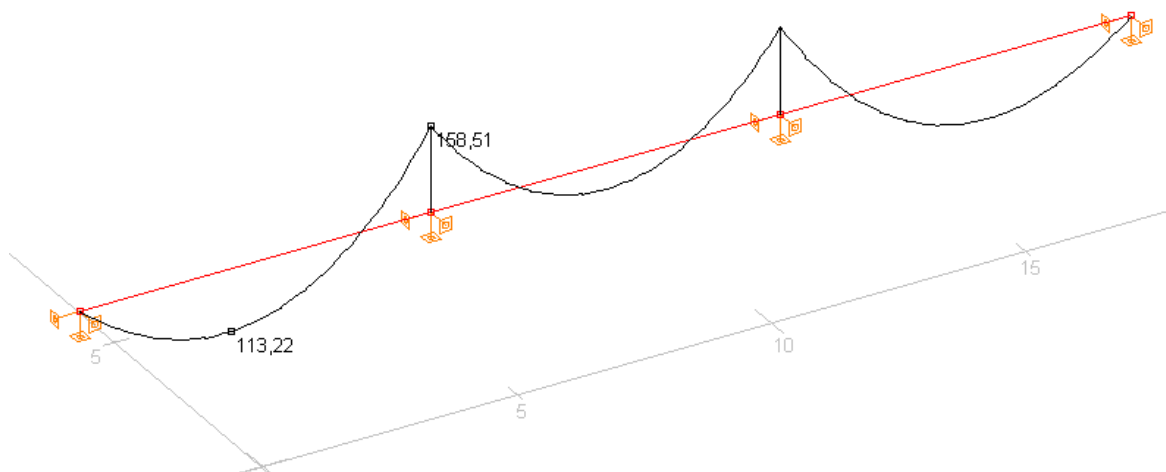

Slika 6.1. Momenti M_z (kNm)

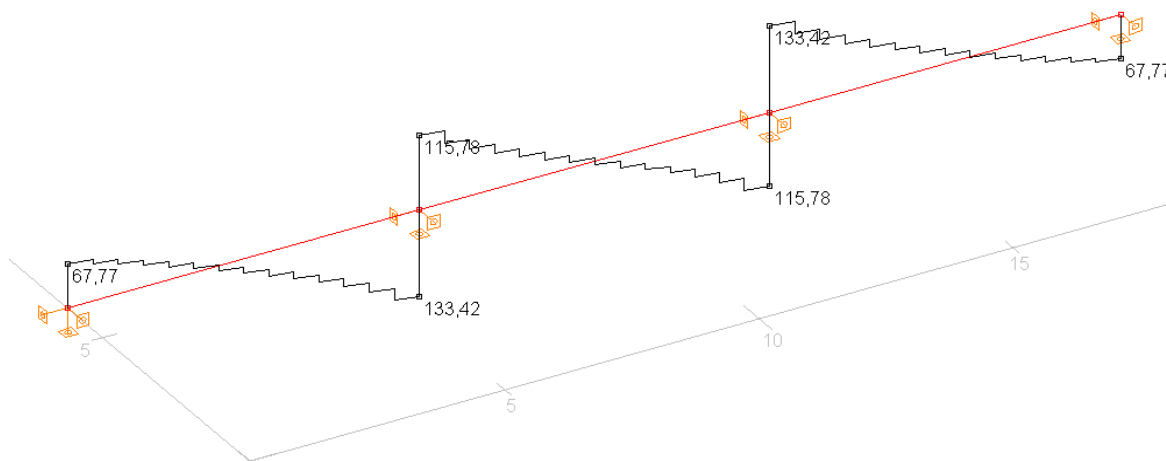

Slika 6.2. Poprečne sile V_y (kN)

6.1.2. Dodatno stalno opterećenje

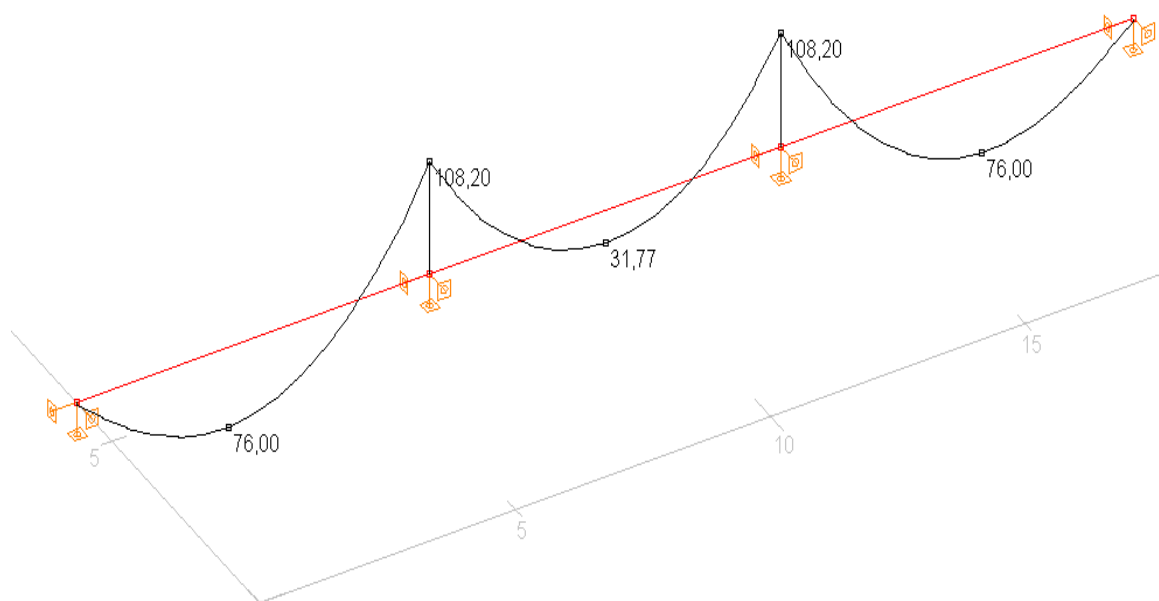

Slika 6.3. Momenti M_z (kNm)

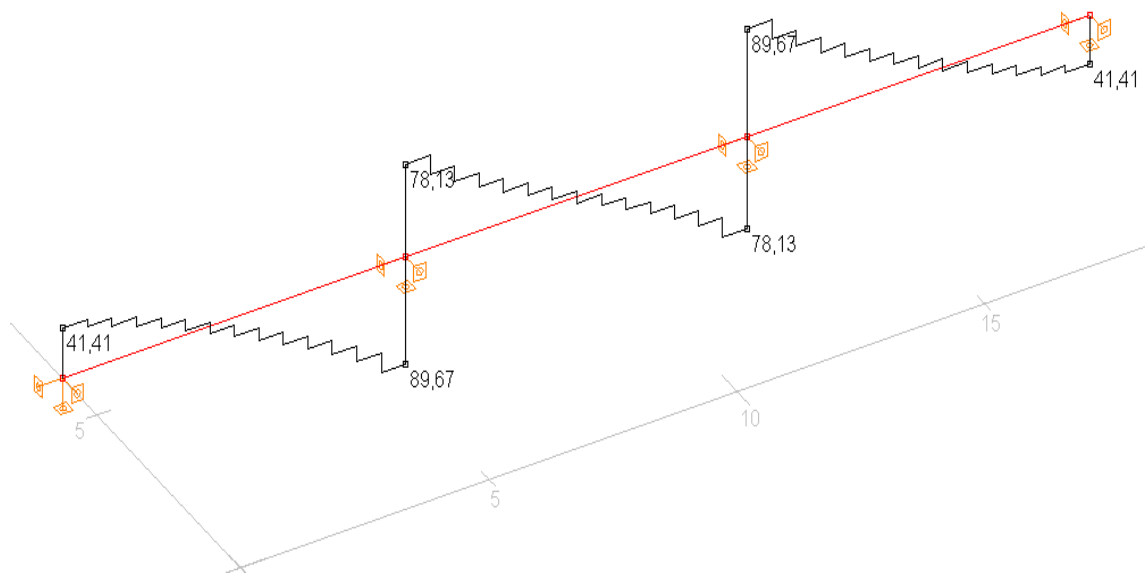

Slika 6.4. Poprečne sile V_y (kN)

6.1.3. Uporabnoopterečenje

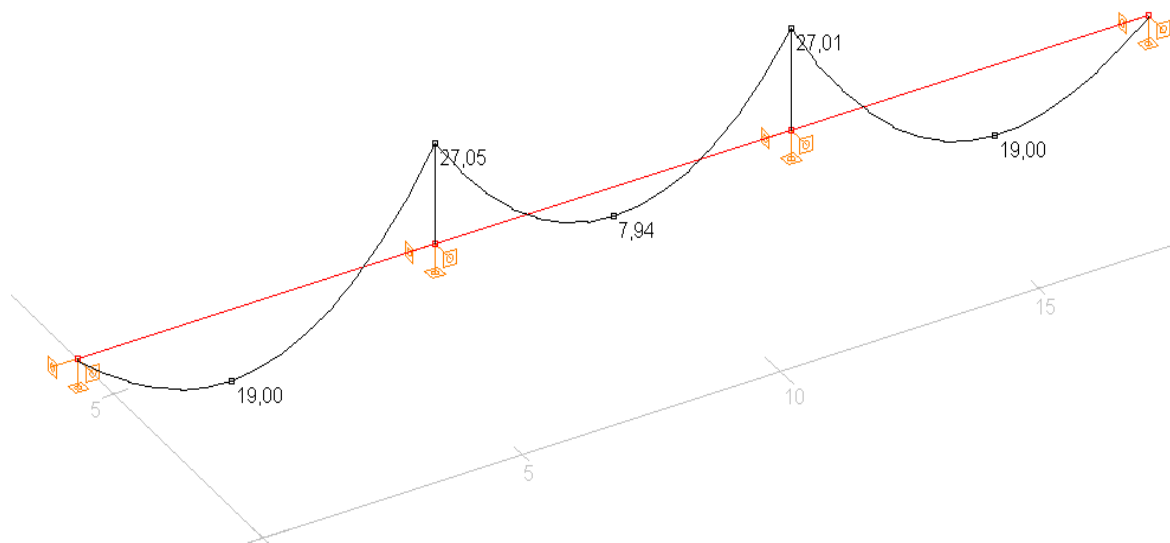

Slika 6.5. Momenti M_z (kNm)

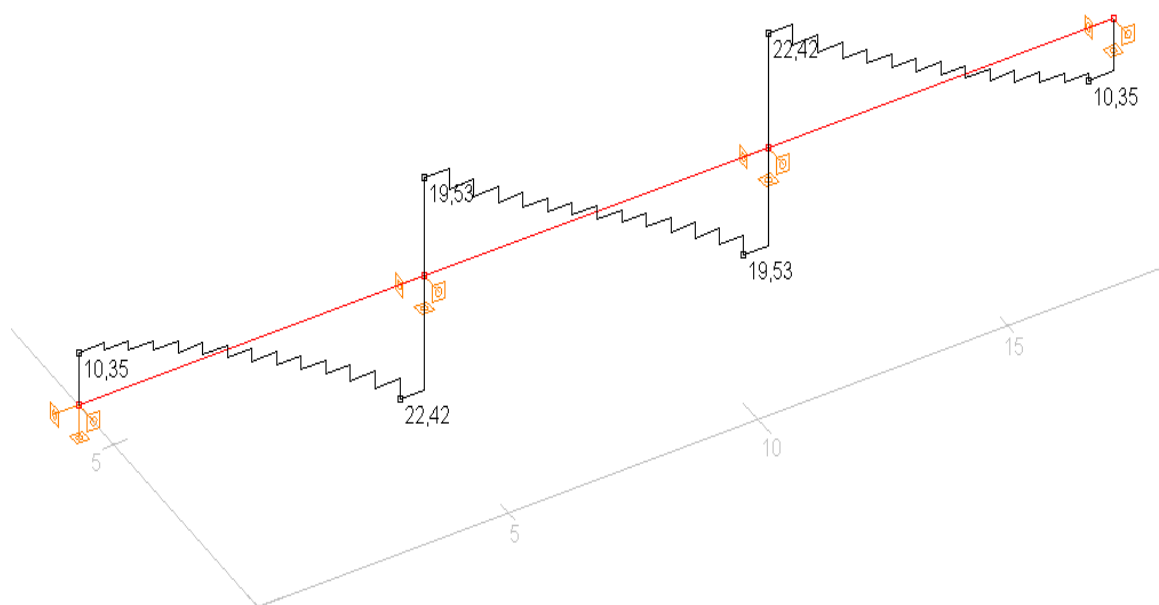

Slika 6.6. Poprečne sile V_y (kN)

6.1.4. Granično stanje nosivosti

Mjerodavna kombinacija: $M_{ed}=1,35*(M_g+M_{\Delta g})+1,5*M_q$

Momenti:

$$M_{Ed, polje1} = 283,96 \text{ kNm}$$

$$M_{Ed, ležaj} = -400,63 \text{ kNm}$$

$$M_{Ed, polje2} = 115,47 \text{ kNm}$$

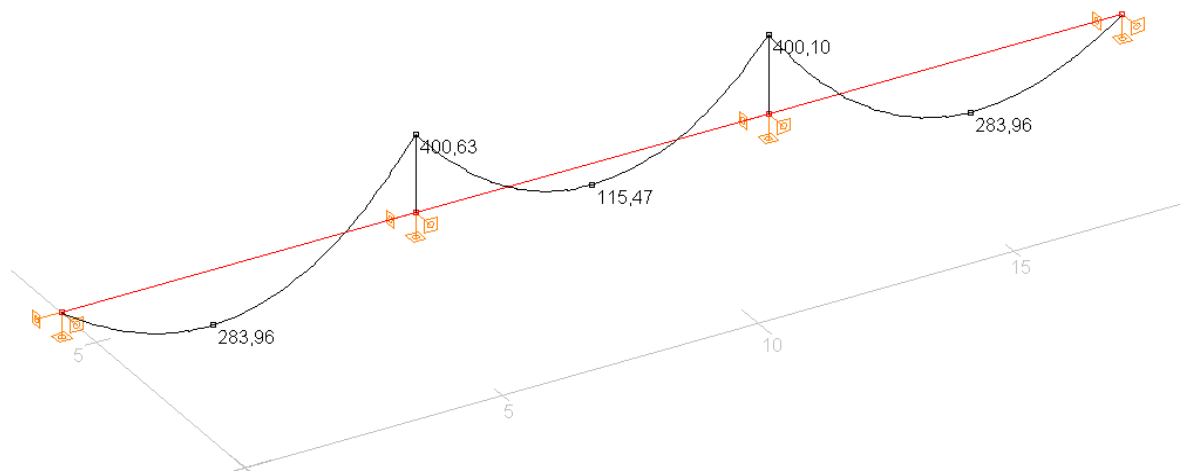

Slika 6.7. Momenti M_z (kNm)

Poprečne sile:

$$V_{Ed, ležaj1} = 334,81 \text{ kN}$$

$$V_{Ed, ležaj0} = 162,93 \text{ kN}$$

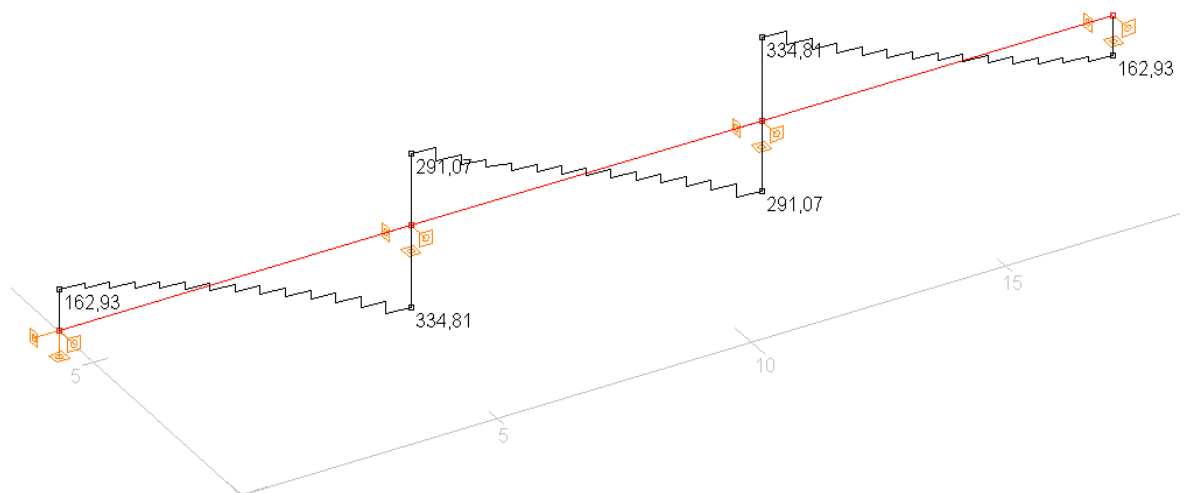

Slika 6.8. Poprečne sile V_y (kN)

6.2. DIMENZIONIRANJE GREDE NA MOMENT SAVIJANJA

BETON: C 40/50;

$$f_{ck} = 40,0 \text{ MPa} = 40 \text{ N/mm}^2; \gamma_c = 1,5$$

$$f_{cd} = f_{ck} / \gamma_c = 40,0 / 1,5 = 26,67 \text{ MPa} = 26,67 \text{ N/mm}^2 = 2,67 \text{ kN/cm}^2$$

ARMATURA: B 500 B;

$$f_{yk} = 500,0 \text{ MPa} = 500 \text{ N/mm}^2; \gamma_s = 1,15$$

$$f_{yd} = f_{yk} / \gamma_s = 500,0 / 1,15 = 434,78 \text{ MPa} = 434,78 \text{ N/mm}^2 = 43,48 \text{ kN/cm}^2$$

Polje 1:

Utjecajna širina: $b_{eff} = b_0 + \frac{l_0}{5} \Rightarrow b_{eff} = 30 + \frac{0,85 \cdot 690}{5} = 147,3 \text{ cm}$

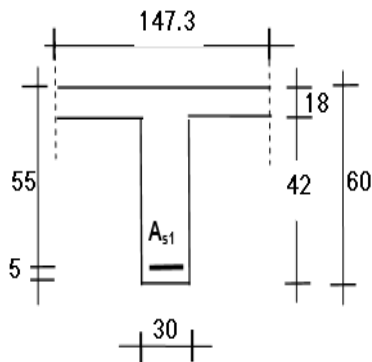

$$d_1 = 5 \text{ cm}$$

$$d = h - d_1 = 60 - 5 = 55 \text{ cm}$$

$$M_{Ed} = 283,96 \text{ kNm}$$

$$\mu_{sd} = \frac{M_{Ed}}{b_{eff} \cdot d^2 \cdot f_{cd}} = \frac{28396}{147,3 \cdot 55^2 \cdot 2,67} = 0,024$$

Očitano:

$$\varepsilon_{s1} = 10,0\text{‰} \quad \varepsilon_{c2} = 0,9\text{‰} \quad \xi = 0,083 \quad \zeta = 0,971$$

$$x = \xi \cdot d = 0,083 \cdot 55 = 4,565 \text{ cm} < h_{pl} = 18 \text{ cm}$$

$$A_{s1} = \frac{M_{Ed}}{\zeta \cdot d \cdot f_{yd}} = \frac{28396}{0,971 \cdot 55 \cdot 43,48} = 12,23 \text{ cm}^2$$

Odabrano 6Ø18 (As=15,27 cm²)

Ležaj:

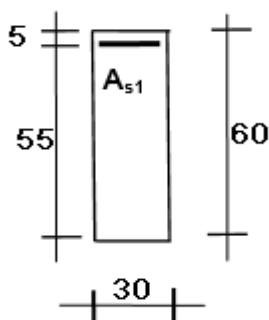

$$d_1 = 5 \text{ cm}$$

$$d = h - d_1 = 60 - 5 = 55 \text{ cm}$$

$$M_{Ed} = 400,63 \text{ kNm}$$

$$\mu_{sd} = \frac{M_{Ed}}{b_w \cdot d^2 \cdot f_{cd}} = \frac{40063}{30 \cdot 55^2 \cdot 2,67} = 0,165$$

Očitano:

$$\varepsilon_{s1} = 5,0\text{‰} \quad \varepsilon_{c2} = 2,3\text{‰} \quad \xi = 0,190 \quad \zeta = 0,879$$

$$x = \xi \cdot d = 0,190 \cdot 55 = 10,45 \text{ cm}$$

$$A_{s1} = \frac{M_{Ed}}{\zeta \cdot d \cdot f_{yd}} = \frac{40063}{0,879 \cdot 55 \cdot 43,48} = 19,06 \text{ cm}^2$$

Odabrano 8Ø18 (As=20,36 cm²)

Polje 2:

Utjecajna širina: $b_{eff} = b_0 + \frac{l_0}{5} \Rightarrow b_{eff} = 30 + \frac{0.70 \cdot 690}{5} = 126.6 \text{ cm}$

$$d_1 = 5 \text{ cm}$$

$$d = h - d_1 = 60 - 5 = 55 \text{ cm}$$

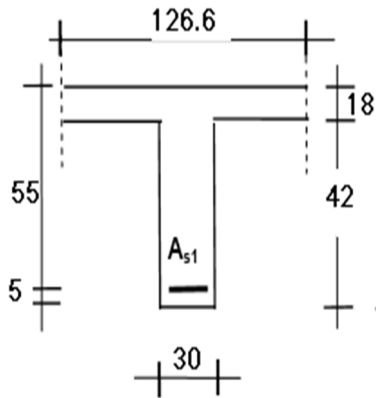

$$M_{Ed} = 115.47 \text{ kNm}$$

$$\mu_{sd} = \frac{M_{Ed}}{b_{eff} \cdot d^2 \cdot f_{cd}} = \frac{11547}{126.6 \cdot 55^2 \cdot 2.67} = 0.011$$

Očitano:

$$\varepsilon_{s1} = 10.0\% \quad \varepsilon_{c2} = 0.6\% \quad \xi = 0.057 \quad \zeta = 0.981$$

$$x = \xi \cdot d = 0.057 \cdot 55 = 3.14 \text{ cm} < h_{pl} = 18 \text{ cm}$$

$$A_{s1} = \frac{M_{Ed}}{\zeta \cdot d \cdot f_{yd}} = \frac{11547}{0.981 \cdot 55 \cdot 43.48} = 4.92 \text{ cm}^2$$

Odabrano 2Ø18 (As=5.09 cm²)

Minimalna armatura:

$$A_{s1, \min} \geq 0,26 \cdot [f_{ct,m} / f_{yk}] \cdot b \cdot t \cdot d \geq 0,0013 \cdot b \cdot t \cdot d$$

b t – širina vlačne zone

d – statička visina presjeka

f_{yk} – karakt. granica popuštanja čelika u N/mm²

[f_{yk} = 500 N/mm² za čelik B 500B]

f_{ct,m} - srednja vlačna čvrstoća betona (iz tablice)

[f_{ct,m} = 3.5 N/mm² za C 40/50]

$$A_{s1, \min} \geq 0,26 \cdot 3.5 / 500 \cdot 30 \cdot 55 = 3.00 \text{ cm}^2$$

$$A_{s1, \min} \geq 0,0013 \cdot b \cdot t \cdot d = 0,0013 \cdot 30 \cdot 55 = 2.145 \text{ cm}^2$$

Maksimalna armatura:

$$A_{s1, \max} = 0.04 \cdot A_c = 0.04 \cdot 30 \cdot 60 = 72 \text{ cm}^2$$

6.3. DIMENZIONIRANJE GREDE NA POPREČNU SILU

Ležaj 1

C 40/50

$$V_{Ed} = 334.81 \text{ kN}$$

$$N_{Ed} = 0.0 \text{ kN}$$

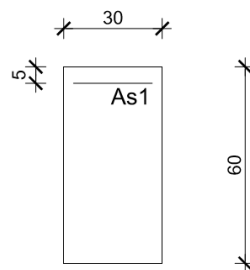

$$A_{s1} = 8\phi 18 = 20.36 \text{ cm}^2$$

$$V_{Rdc} = \left[C_{Rdc} \cdot k \cdot (100 \cdot \rho_l \cdot f_{ck})^{\frac{1}{3}} + k_1 \cdot \sigma_{cp} \right] \cdot b_w \cdot d$$

$$b_w = 30 \text{ cm} ; d = 55 \text{ cm}$$

$$k = 1 + \sqrt{\frac{200}{d}} = 1 + \sqrt{\frac{200}{550}} = 1.60 \leq 2$$

$$k_1 = 0.15$$

$$\sigma_{cp} = \frac{N_{sd}}{A_c} = 0.0$$

$$\Sigma A_s = 8\phi 18 = 20.36 \text{ cm}^2$$

$$\rho_l = \frac{\Sigma A_s}{A_c} = \frac{20.36}{30 \cdot 55} = \frac{20.36}{1650} = 0.0123$$

$$C_{Rdc} = \frac{0.18}{\gamma_c} = \frac{0.18}{1.5} = 0.12$$

$$V_{Rdc} = \left[0.12 \cdot 1.60 \cdot (100 \cdot 0.0123 \cdot 40)^{\frac{1}{3}} \right] \cdot 300 \cdot 550 = 116.08 \text{ kN}$$

$$V_{Rdc} \geq [v_{\min} + k_1 \cdot \sigma_{cp}] \cdot b_w \cdot d$$

$$v_{\min} = 0.035 \cdot k^{\frac{3}{2}} \cdot f_{ck}^{\frac{1}{2}} = 0.035 \cdot 1.60^{\frac{3}{2}} \cdot 40^{\frac{1}{2}} = 0.448$$

$$\sigma_{cp} = \frac{N_{sd}}{A_c} = 0.0$$

$$V_{Rdc} \geq v_{\min} \cdot b_w \cdot d = 0.448 \cdot 300 \cdot 550 = 73.92 \text{ kN} \leq V_{Ed}$$

$$V_{Ed, \max} = V_{Ed} = 334.81 \text{ kN}$$

$$V_{Rd, \max} = 0.5 \cdot v \cdot b_w \cdot d \cdot f_{cd}$$

$$v = 0.6 \cdot \left[1 - \frac{f_{ck}}{250} \right] = 0.6 \cdot \left[1 - \frac{40}{250} \right] = 0.504$$

$$V_{Rd, \max} = 0.5 \cdot 0.504 \cdot 300 \cdot 550 \cdot 26.67 = 1108.94 \text{ kN} > V_{Ed, \max} = V_{Ed}$$

$$V_{Ed,max} / V_{Rd,max} = 334.81 / 1108.94 = 0.0302 \approx 0.030 \Rightarrow V_{Ed} = 0.30 V_{Rd,max}$$

$$s_{max} = \min\{0.55 \cdot d; 30\} = \min\{30.25; 30\} \Rightarrow s_{max} = 30.0 \text{ cm}$$

$$\rho_{min} = 0.0013$$

Površina minimalne armature:

$$A_{sw,min} = \frac{\rho_{min} \cdot s_w \cdot b_w}{m} = \frac{0.0013 \cdot 30 \cdot 30}{2} = 0.585 \text{ cm}^2$$

Odabrane minimalne spone: **Ø10/30** ($A_{sw}=0.79 \text{ cm}^2$)

$$f_{yw,d} = \frac{f_{yk}}{\gamma_s}; B500B \Rightarrow f_{ywd} = \frac{500}{1.15} = 434.8 \text{ MPa} = 43.48 \text{ kN / cm}^2$$

$$V_{Rd} = V_{Rd,s} = \frac{A_{sw}}{s} \cdot z \cdot f_{ywd} \cdot m \cdot \text{ctg} \theta = \frac{0.79}{30} \cdot (0.9 \cdot 55) \cdot 43.48 \cdot 2 \cdot 1 = 113.35$$

$$V_{Ed} > V_{Rd}$$

Na mjestu maksimalne poprečne sile:

$$s_w \leq \frac{m \cdot A_{sw} \cdot f_{yw,d} \cdot z}{V_{Ed}} = \frac{2 \cdot 0.79 \cdot 43.48 \cdot 0.9 \cdot 55}{334.81} = 10.15 \text{ cm}$$

Odabrane spone: **Ø10/10cm** ($A_{sw}=0.79 \text{ cm}^2$)

Ležaj 0

C 40/50

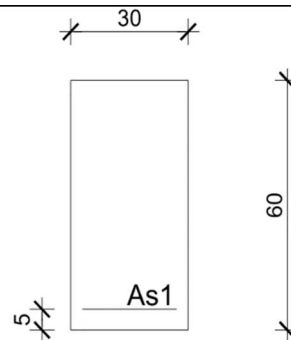
 $V_{Ed} = 162.93 \text{ kN}$ $N_{Ed} = 0.0 \text{ kN}$ 

$$As1 = 6\phi 18 = 15.27 \text{ cm}^2$$

$$V_{Rdc} = \left[C_{Rdc} \cdot k \cdot (100 \cdot \rho_l \cdot f_{ck})^{\frac{1}{3}} + k_1 \cdot \sigma_{cp} \right] \cdot b_w \cdot d$$

$$b_w = 30 \text{ cm} ; \quad d = 55 \text{ cm}$$

$$k = 1 + \sqrt{\frac{200}{d}} = 1 + \sqrt{\frac{200}{550}} = 1.60 \leq 2$$

$$k_1 = 0.15$$

$$\sigma_{cp} = \frac{N_{sd}}{A_c} = 0.0$$

$$\Sigma A_s = 6\phi 18 = 15.27 \text{ cm}^2$$

$$\rho_l = \frac{\Sigma A_s}{A_c} = \frac{15.27}{30 \cdot 55} = \frac{15.27}{1650} = 0.0093$$

$$C_{Rdc} = \frac{0.18}{\gamma_c} = \frac{0.18}{1.5} = 0.12$$

$$V_{Rdc} = \left[0.12 \cdot 1.60 \cdot (100 \cdot 0.0093 \cdot 40)^{\frac{1}{3}} \right] \cdot 300 \cdot 550 = 105.75 \text{ kN}$$

$$V_{Rdc} \geq [v_{\min} + k_1 \cdot \sigma_{cp}] \cdot b_w \cdot d$$

$$v_{\min} = 0.035 \cdot k^{\frac{3}{2}} \cdot f_{ck}^{\frac{1}{2}} = 0.035 \cdot 1.60^{\frac{3}{2}} \cdot 40^{\frac{1}{2}} = 0.448$$

$$\sigma_{cp} = \frac{N_{sd}}{A_c} = 0.0$$

$$V_{Rdc} \geq v_{\min} \cdot b_w \cdot d = 0.448 \cdot 300 \cdot 550 = 73.92 \text{ kN} \leq V_{Ed}$$

$$V_{Ed, \max} = V_{Ed} = 162.93 \text{ kN}$$

$$V_{Rd, \max} = 0.5 \cdot v \cdot b_w \cdot d \cdot f_{cd}$$

$$v = 0.6 \cdot \left[1 - \frac{f_{ck}}{250} \right] = 0.6 \cdot \left[1 - \frac{40}{250} \right] = 0.504$$

$$V_{Rd, \max} = 0.5 \cdot 0.504 \cdot 300 \cdot 550 \cdot 26.67 = 1108.94 \text{ kN} > V_{Ed, \max} = V_{Ed}$$

$$V_{Ed,max} / V_{Rd,max} = 162.93 / 1108.94 = 0.147 \approx 0.15 \Rightarrow V_{Ed} = 0.15 V_{Rd,max}$$

$$s_{max} = \min\{0.75 \cdot d; 30\} = \min\{41.25; 30\} \Rightarrow s_{max} = 30.0 \text{ cm}$$

$$\rho_{min} = 0.0013$$

Površina minimalne armature:

$$A_{sw,min} = \frac{\rho_{min} \cdot s_w \cdot b_w}{m} = \frac{0.0013 \cdot 30 \cdot 30}{2} = 0.585 \text{ cm}^2$$

Odabrane minimalne spone: **Ø10/30** ($A_{sw}=0.79 \text{ cm}^2$)

$$f_{yw,d} = \frac{f_{yk}}{\gamma_s}; B500B \Rightarrow f_{yw,d} = \frac{500}{1.15} = 434.8 \text{ MPa} = 43.48 \text{ kN / cm}^2$$

$$V_{Rd} = V_{Rd,s} = \frac{A_{sw}}{s} \cdot z \cdot f_{yw,d} \cdot m \cdot ctg \theta$$
$$= \frac{0.79}{30} \cdot (0.9 \cdot 55) \cdot 43.48 \cdot 2 \cdot 1 = 113.35 \text{ kN}$$

$$V_{Ed} > V_{Rd}$$

Na mjestu maksimalne poprečne sile:

$$s_w \leq \frac{m \cdot A_{sw} \cdot f_{yw,d} \cdot z}{V_{Ed}} = \frac{2 \cdot 0.79 \cdot 43.48 \cdot 0.9 \cdot 55}{162.93} = 20.87 \text{ cm}$$

Odabrane spone: **Ø10/20cm** ($A_{sw}=0.79 \text{ cm}^2$)

6.4. KONTROLA PUKOTINA GREDE POZICIJE 200

- Kontrola pukotina i progib grede proračunava se na granično stanje uporabljivosti. Mjerodavna kombinacija djelovanja za proračun graničnog stanja uporabljivosti je:
1.0 vlastita težina "+" 1.0 dodatno stalno "+" 1.0 uporabno

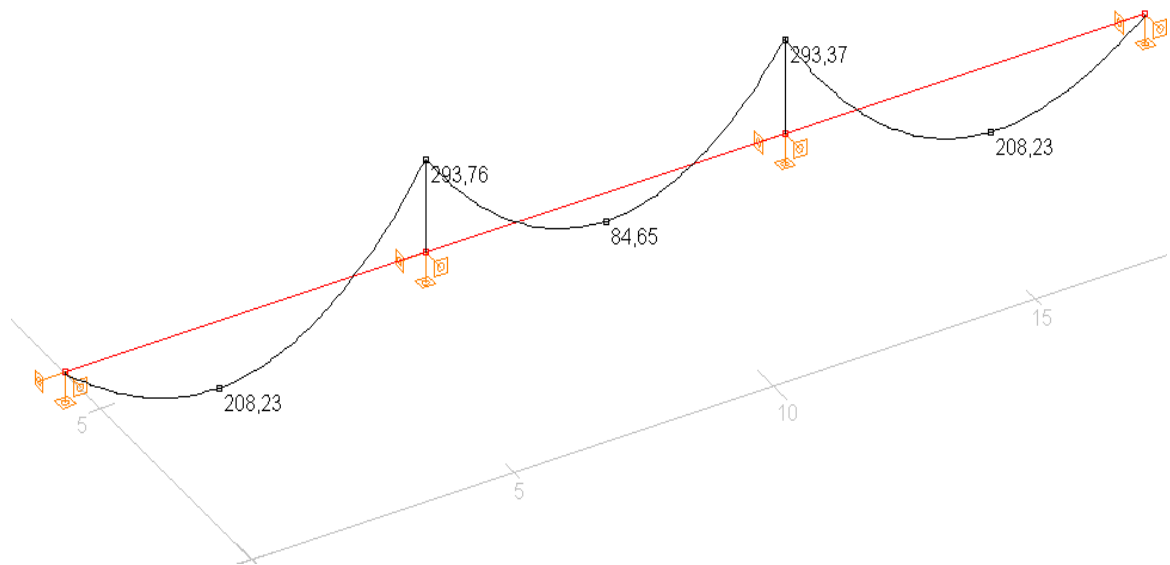

Slika 6.9.Moment (kNm)

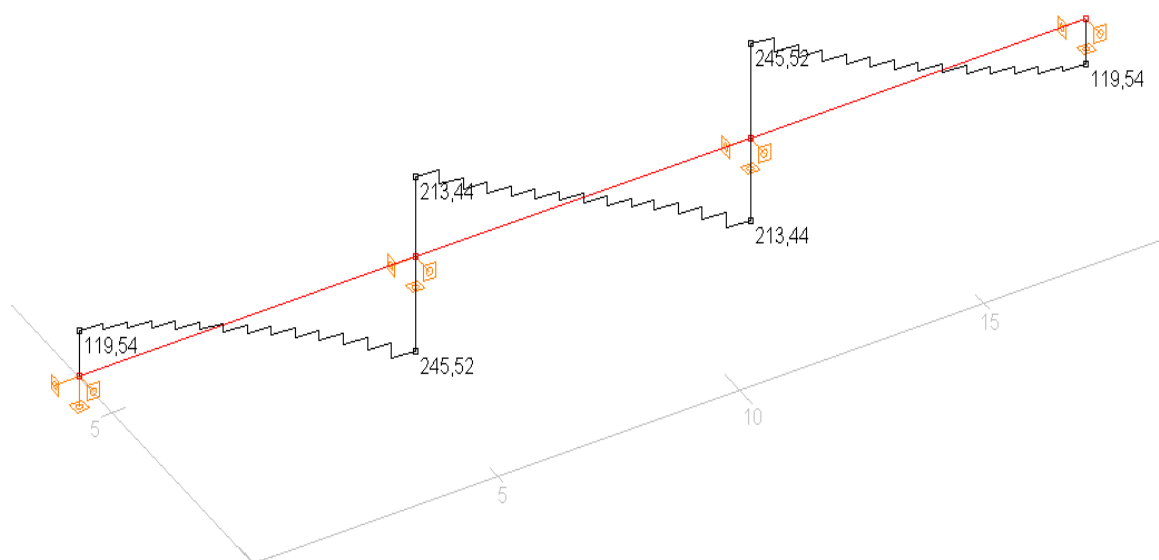

Slika 6.10.Poprečna sila (kN)

Polje 1:

$$M_{Ed} = 208.23 \text{ kNm}$$

Prognoza širine pukotine:

$$w_k = S_{r,max} \cdot (\varepsilon_{s,m} - \varepsilon_{c,m})$$

Proračun srednje deformacije armature:

$$(\varepsilon_{sm} - \varepsilon_{cm}) = \frac{\sigma_s - k_t \cdot \frac{f_{ct,eff}}{\rho_{p,eff}} \cdot (1 + \alpha_e \cdot \rho_{p,eff})}{E_s} \geq 0.6 \cdot \frac{\sigma_s}{E_s}$$

$$E_{cm} = 35.00 \text{ GPa} = 35000 \text{ MPa} - \text{modul elastičnosti betona}$$

$$E_s = 200.0 \text{ GPa} = 200000.0 \text{ MPa} - \text{modul elastičnosti armature}$$

$$f_{ctm} = 3.5 \text{ MPa} - \text{za betone klase C 40/50}$$

$$k_t = 0.4 - \text{dugotrajno opterećenje}$$

$$\alpha_e = \frac{E_s}{E_{cm}} = \frac{200}{35.0} = 5.71$$

$$x = \frac{\alpha_e \cdot A_{s1}}{b} \cdot \left(-1 + \sqrt{1 + \frac{2 \cdot b \cdot d}{\alpha_e \cdot A_{s1}}} \right) = \frac{5.71 \cdot 15.27}{30} \cdot \left(-1 + \sqrt{1 + \frac{2 \cdot 30 \cdot 55}{5.71 \cdot 15.27}} \right) = 15.21 \text{ cm}$$

$$\sigma_s = \frac{M_{Ed}}{z \cdot A_{s1}} \approx \frac{M_{Ed}}{\left(d - \frac{x}{3}\right) \cdot A_{s1}} = \frac{20823}{\left(55 - \frac{15.21}{3}\right) \cdot 15.27} = 27.31 \text{ kN/cm}^2 = 273.11 \text{ MPa}$$

$$\rho_{p,eff} = \frac{A_{s1}}{A_{c,eff}} = \frac{A_{s1}}{b \cdot 2.5 \cdot d_1} = \frac{15.27}{30 \cdot 2.5 \cdot 5.0} = 0.040$$

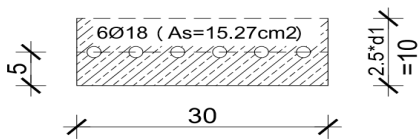

$$(\varepsilon_{sm} - \varepsilon_{cm}) = \frac{273.11 - 0.4 \cdot \frac{3.5}{0.040} \cdot (1 + 5.71 \cdot 0.040)}{200000} \geq 0.6 \cdot \frac{273.11}{200000}$$

$$\frac{230.12}{200000} > \frac{163.86}{200000}$$

$$(\varepsilon_{sm} - \varepsilon_{cm}) = 0.00115$$

Proračun srednjeg razmaka pukotina:

$$S_{r,max} = k_3 \cdot c + k_1 \cdot k_2 \cdot k_4 \cdot \frac{\phi}{\rho_{p,eff}}$$

$\phi = 18 \text{ mm}$ – promjer najdeblje šipke

$k_1 = 0.8$ - Rebrasta armatura

$k_2 = 0.5$ – Savijanje

$k_3 = 3.4$

$k_4 = 0.425$

$c = d_1 - \frac{\phi}{2} = 50 - \frac{18}{2} = 41 \text{ mm}$ - zaštitni sloj uzdužne armature

$$S_{r,max} = 3.4 \cdot 41 + 0.8 \cdot 0.5 \cdot 0.425 \cdot \frac{18}{0.034} = 229.4 \text{ mm}$$

$$W_k = w_k = S_{r,max} \cdot (\varepsilon_{s,m} - \varepsilon_{c,m}) = 229.4 \cdot 0.00115 = 0.264 \text{ mm} \leq 0.300 \text{ mm}$$

→ pukotine zadovoljavaju

Ležaj:

$$M_{Ed} = 293.76 \text{ kNm}$$

Prognoza širine pukotine:

$$w_k = S_{r,max} \cdot (\varepsilon_{s,m} - \varepsilon_{c,m})$$

Proračun srednje deformacije armature:

$$(\varepsilon_{sm} - \varepsilon_{cm}) = \frac{\sigma_s - k_t \cdot \frac{f_{ct,eff}}{\rho_{p,eff}} \cdot (1 + \alpha_e \cdot \rho_{p,eff})}{E_s} \geq 0.6 \cdot \frac{\sigma_s}{E_s}$$

$E_{cm} = 35.00 \text{ GPa} = 35000 \text{ MPa}$ – modul elastičnosti betona

$E_s = 200.0 \text{ GPa} = 200000.0 \text{ MPa}$ – modul elastičnosti armature

$f_{ctm} = 3.5 \text{ MPa}$ - za betone klase C 40/50

$k_t = 0.4$ - dugotrajno opterećenje

$$\alpha_e = \frac{E_s}{E_{cm}} = \frac{200}{35,0} = 5.71$$

$$x = \frac{\alpha_e \cdot A_{s1}}{b} \cdot \left(-1 + \sqrt{1 + \frac{2 \cdot b \cdot d}{\alpha_e \cdot A_{s1}}} \right) = \frac{5.71 \cdot 20.26}{30} \cdot \left(-1 + \sqrt{1 + \frac{2 \cdot 30 \cdot 55}{5.71 \cdot 20.26}} \right) = 17.10 \text{ cm}$$

$$\sigma_s = \frac{M_{Ed}}{z \cdot A_{s1}} \approx \frac{M_{Ed}}{\left(d - \frac{x}{3} \right) \cdot A_{s1}} = \frac{29376}{\left(55 - \frac{17.10}{3} \right) \cdot 20.26} = 29.41 \text{ kN /cm}^2 = 290.41 \text{ Mpa}$$

$$\rho_{p,eff} = \frac{A_{s1}}{A_{c,eff}} = \frac{A_{s1}}{b \cdot 2.5 \cdot d_1} = \frac{20.26}{30 \cdot 2.5 \cdot 5.0} = 0.054$$

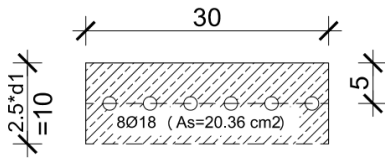

$$(\varepsilon_{sm} - \varepsilon_{cm}) = \frac{290.41 - 0.4 \cdot \frac{3.5}{0.054} \cdot (1 + 5.71 \cdot 0.054)}{200000} \geq 0.6 \cdot \frac{290.41}{200000}$$

$$\frac{256.49}{200000} > \frac{174.25}{200000}$$

$$(\varepsilon_{sm} - \varepsilon_{cm}) = 0.00128$$

Proračun srednjeg razmaka pukotina:

$$S_{r,max} = k_3 \cdot c + k_1 \cdot k_2 \cdot k_4 \cdot \frac{\phi}{\rho_{p,eff}}$$

$\phi = 18$ mm – promjer najdeblje šipke

$k_1 = 0.8$ - Rebrasta armatura

$k_2 = 0.5$ – Savijanje

$k_3 = 3.4$

$k_4 = 0.425$

$c = d_1 - \frac{\phi}{2} = 50 - \frac{18}{2} = 41$ mm - zaštitni sloj uzdužne armature

$$S_{r,max} = 3.4 \cdot 41 + 0.8 \cdot 0.5 \cdot 0.425 \cdot \frac{18}{0.054} = 196.07 \text{ mm}$$

$$W_k = w_k = S_{r,max} \cdot (\varepsilon_{s,m} - \varepsilon_{c,m}) = 196.07 \cdot 0.00128 = 0.251 \text{ mm} \geq 0.300 \text{ mm}$$

→ pukotine zadovoljavaju

6.5. KONTROLA PROGIBA GREDE POZICIJE 200

Progib kontroliramo za nefaktorizirano opterećenje i bez utjecaja puzanja.

Kontrola progiba za Polje 1:

Granični progib:

$$v_{lim} = \frac{L}{250} = \frac{690}{250} = 2.76 \text{ cm}$$

Beton: C 40/50; $f_{ck}=40.0 \text{ MPa}$

$$E_{cm} = 9500 \cdot \sqrt[3]{f_{ck} + 8} = 9500 \cdot \sqrt[3]{40 + 8} \approx 35000 \text{ MPa}$$

$$f_{ctm} = 0.3 \cdot (f_{ck})^{2/3} = 0.3 \cdot (40.0)^{2/3} = 3.5 \text{ MPa}$$

Čelik: B500B ; $E_s= 200.0 \text{ GPa}$

$$\alpha_{el} = \frac{E_s}{E_{cm}} = \frac{200.0}{35} = 5.71$$

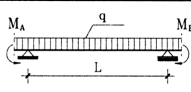
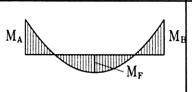
Red	Tip opterećenja	Dijagram momenata savijanja	Koeficijent k iz izraza (5.131)
7			$k = \frac{5}{48} (1 - 0.1\beta)$ $\beta = M_A + M_B / M_F $

$$v_{tot} = k \cdot L^2 \cdot \frac{1}{r_{tot}}$$

$$\beta = |M_A + M_B| / |M_F| = |0.0 + 293.76| / |208.23| = 1.411$$

$$k = \frac{5}{48} \cdot (1 - 0.1 \cdot \beta) = 0.104 \cdot (1 - 0.1 \cdot 1.411) = 0.0893$$

Presjek u polju :

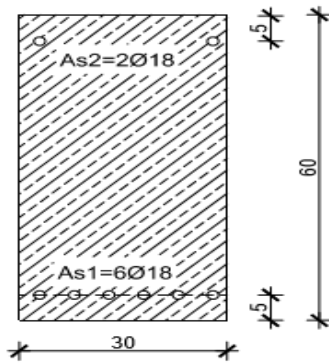

$$A_{s1} = 6\text{Ø}18 = 15.27 \text{ cm}^2$$

$$A_{s2} = 2\text{Ø}18 = 5.09 \text{ cm}^2$$

$$I_1 = \frac{bh^3}{12} + \alpha_{el} \cdot \left[A_{s1} \cdot \left(\frac{h}{2} - d_2 \right)^2 + A_{s2} \cdot \left(\frac{h}{2} - d_1 \right)^2 \right]$$

$$= \frac{30 \cdot 60^3}{12} + 5.71 \cdot \left[15.27 \cdot \left(\frac{60}{2} - 5 \right)^2 + 5.09 \cdot \left(\frac{60}{2} - 5 \right)^2 \right] =$$

$$= 612659.75 \text{ cm}^4$$

$$E_{c,eff} = E_{cm} = 35.0 \text{ GN/m}^2 = 3500.0 \text{ kN/cm}^2$$

$$\frac{1}{r_I} = \frac{M_{Ed}}{E_{c,eff} \cdot I_1} = \frac{20823}{3500 \cdot 612659.75} = 0.00000971 \frac{1}{\text{cm}}$$

Progib potpuno raspucanog presjeka:

$x = 15.21 \text{ cm}$ (izračunato kod pukotina)

$$I_{II} = \frac{bx^3}{12} + bx \cdot \left(\frac{x}{2} \right)^2 + \alpha_{el} \cdot \left[A_{s1} \cdot (d - x)^2 + A_{s2} \cdot (x - d_2)^2 \right]$$

$$= \frac{30 \cdot 15.21^3}{12} + (30 \cdot 15.21) \cdot \left(\frac{15.21}{2} \right)^2 + 5.71 \cdot \left[15.27 \cdot (55 - 15.21)^2 + 5.09 \cdot (15.21 - 5)^2 \right]$$

$$= 176262.92 \text{ cm}^4$$

$$\frac{1}{r_{II}} = \frac{M_{Ed}}{E_{c,eff} \cdot I_{II}} = \frac{20823}{3500 \cdot 176262.92} = 0.0000338 \frac{1}{\text{cm}}$$

$$\sigma_s = 27311 \text{ MPa}$$

$$\sigma_{sr} = \frac{M_{cr}}{\left(d - \frac{x}{3}\right) \cdot A_{s1}}$$

$$M_{cr} = f_{ctm} \cdot W = f_{ctm} \cdot \frac{b \cdot h^2}{6} = 0.35 \cdot \frac{30 \cdot 60^2}{6} = 6300 \text{ kNcm}$$

$$\sigma_{sr} = \frac{6300}{\left(55 - \frac{15.21}{3}\right) \cdot 15.27} = 8.26 \frac{\text{kN}}{\text{cm}^2} = 82.6 \text{ MPa}$$

$\beta_1 = 1.0$ - Rebrasta armatura

$\beta_2 = 0.5$ - Dugotrajno opterećenje

$$\zeta = 1 - \beta_1 \cdot \beta_2 \cdot \left(\frac{\sigma_{sr}}{\sigma_s}\right)^2 = 1 - 1.0 \cdot 0.5 \cdot \left(\frac{82.6}{273.11}\right)^2 = 0.954$$

$$\frac{1}{r_I} = 0.00000971 \frac{1}{\text{cm}}$$

$$\frac{1}{r_{II}} = 0.0000338 \frac{1}{\text{cm}}$$

$$\frac{1}{r_m} = (1 - \zeta) \cdot \frac{1}{r_I} + \zeta \cdot \frac{1}{r_{II}} = (1 - 0.954) \cdot 0.00000971 + 0.954 \cdot 0.0000338 = 0.000033 \frac{1}{\text{cm}}$$

$$k = 0.0893$$

$$L = 690.0 \text{ cm}$$

$$v_{tot,t=0} = k \cdot L^2 \cdot \frac{1}{r_{tot}} = 0.0893 \cdot 690.0^2 \cdot 0.000033 = 1.40 \text{ cm} < v_{lim} = 2.76 \text{ cm}$$

7. PRORAČUN KONTINUIRANOG NOSAČA POZICIJE 100

7.1. MOMENTI SAVIJANJA I POPREČNE SILE GREDE POZICIJE 100

7.1.1. Vlastita težina

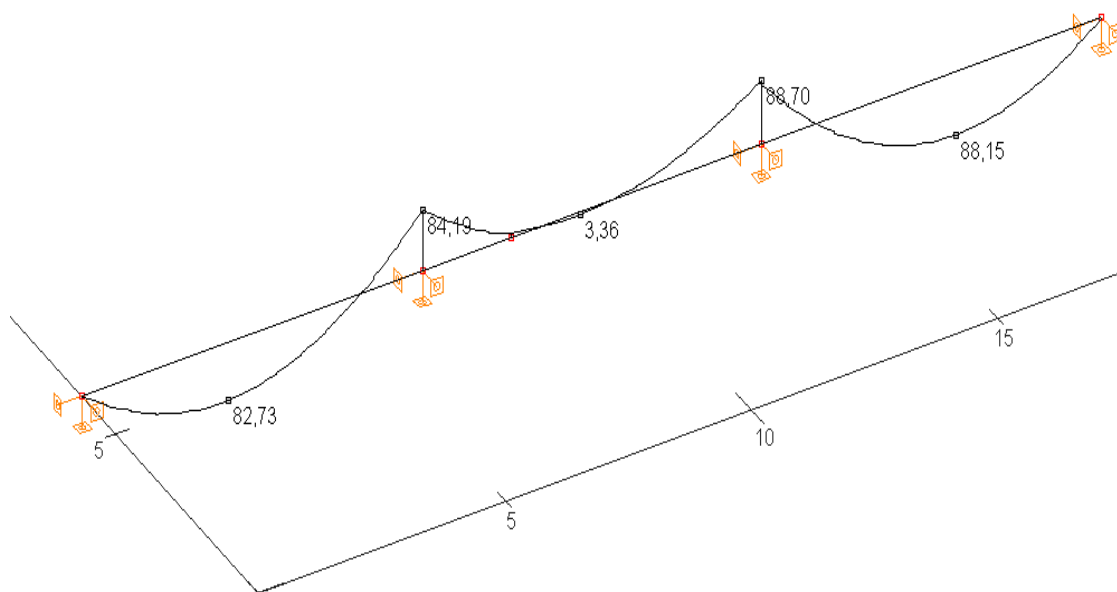

Slika 7.1. Momenti M_z (kNm)

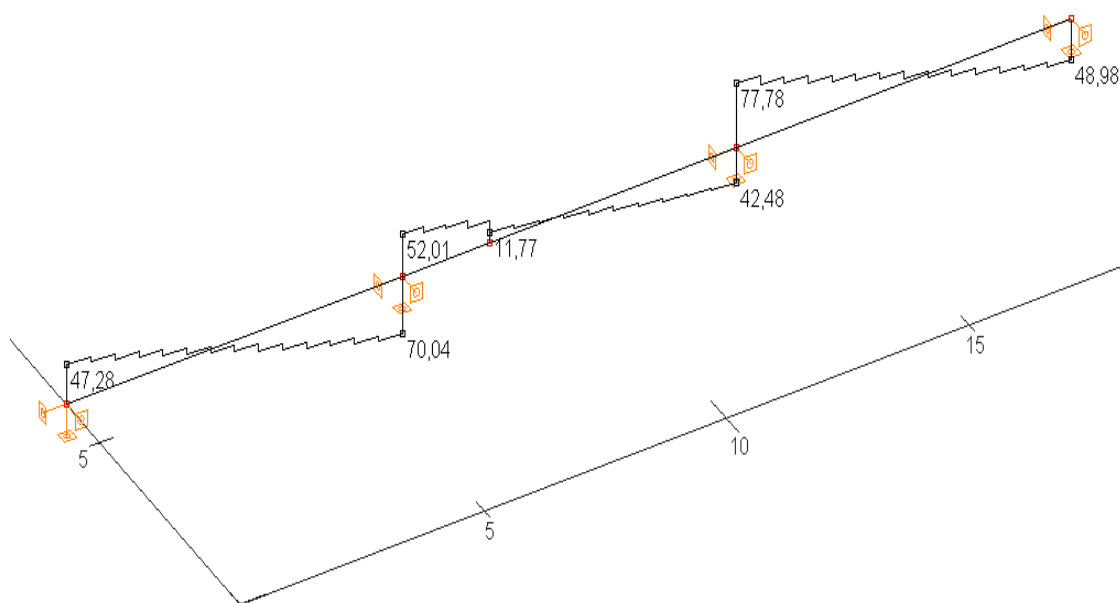

Slika 7.2. Poprečne sile V_y (kN)

7.1.2. Dodatno stalno opterećenje

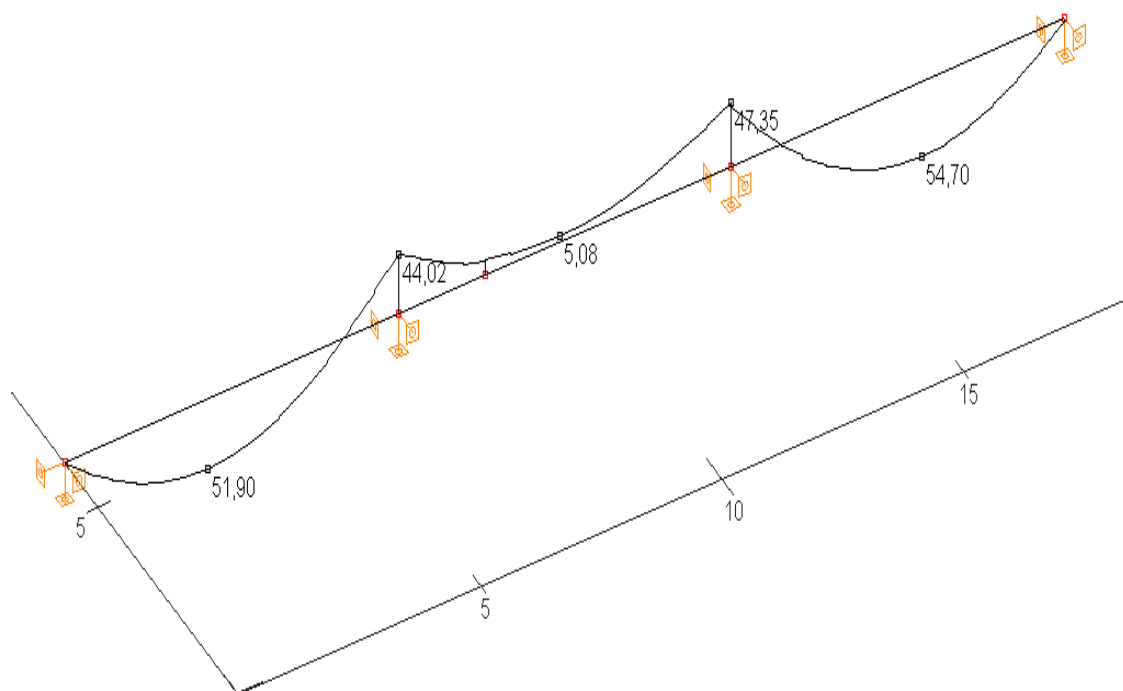

Slika 7.3. Momenti M_z (kNm)

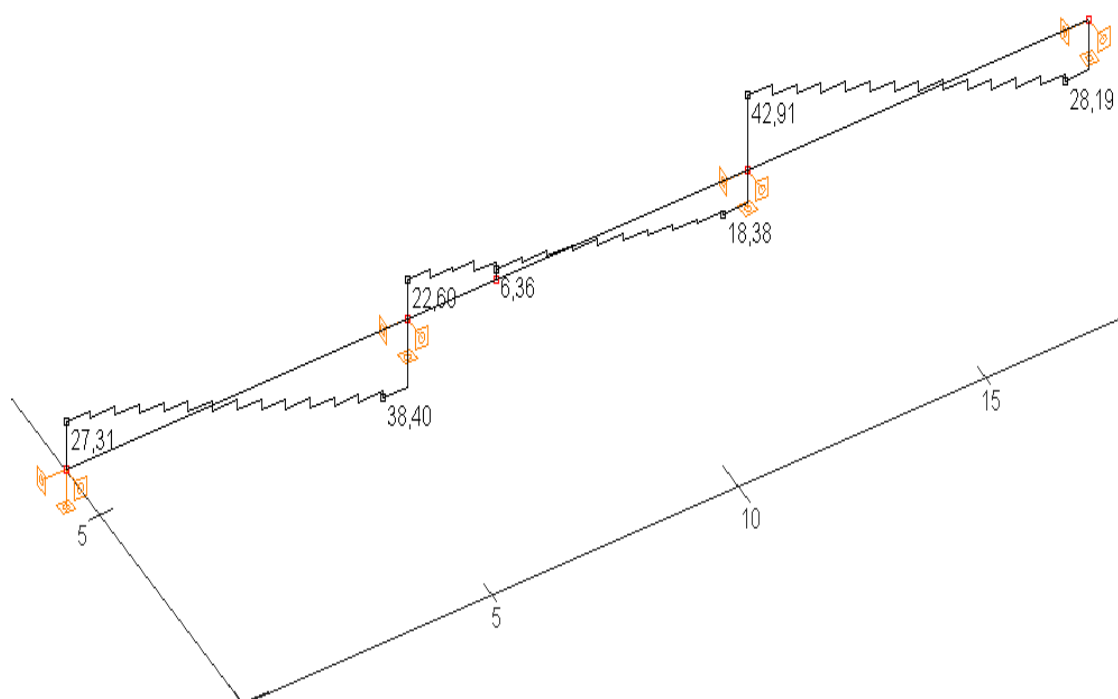

Slika 7.4. Poprečne sile V_y (kN)

7.1.3. Uporabno opterećenje shema 4 (max sile u krajnjim poljima)

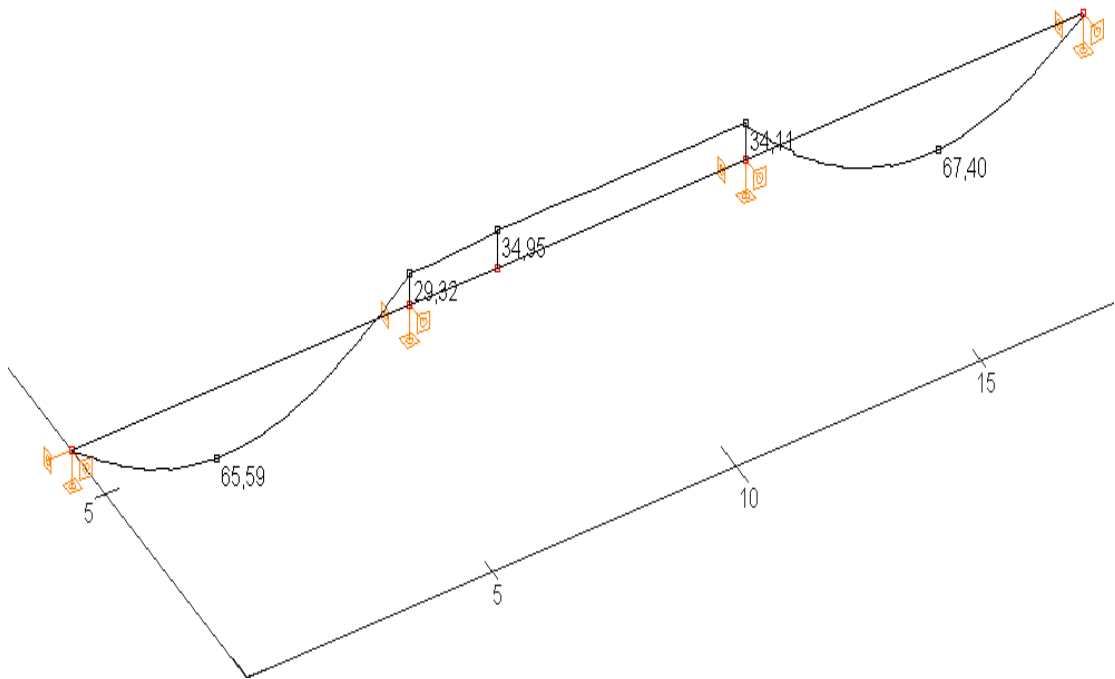

Slika 7.5. Momenti M_z (kNm)

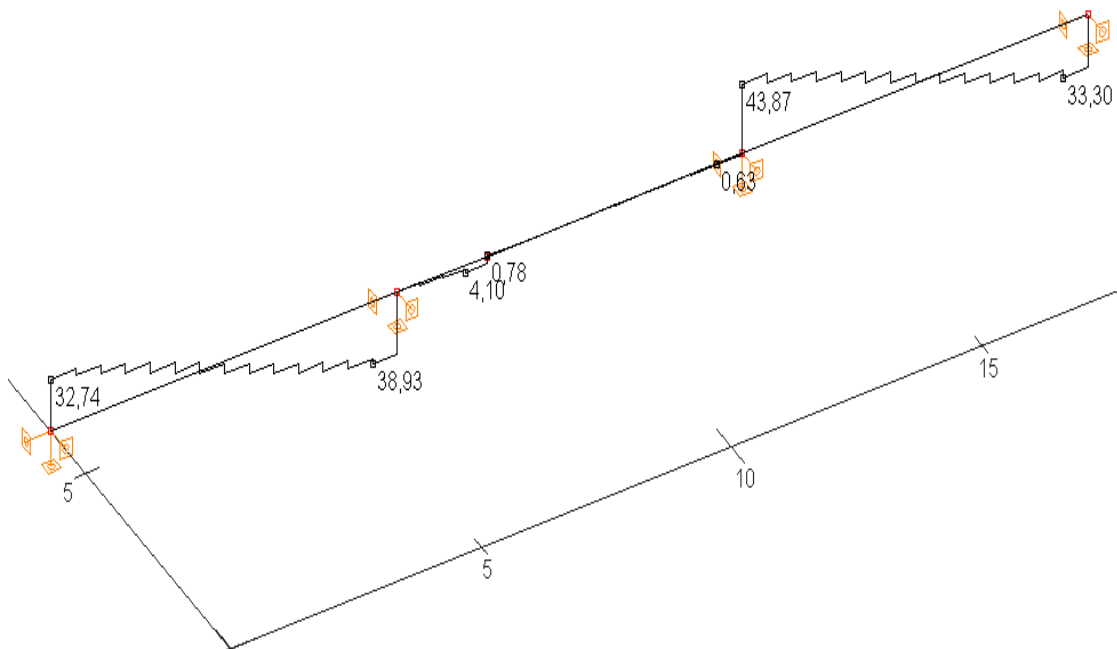

Slika 7.6. Poprečne sile V_y (kN)

7.1.4. Uporabno opterećenje shema 5 (max sile u srednjem polju)

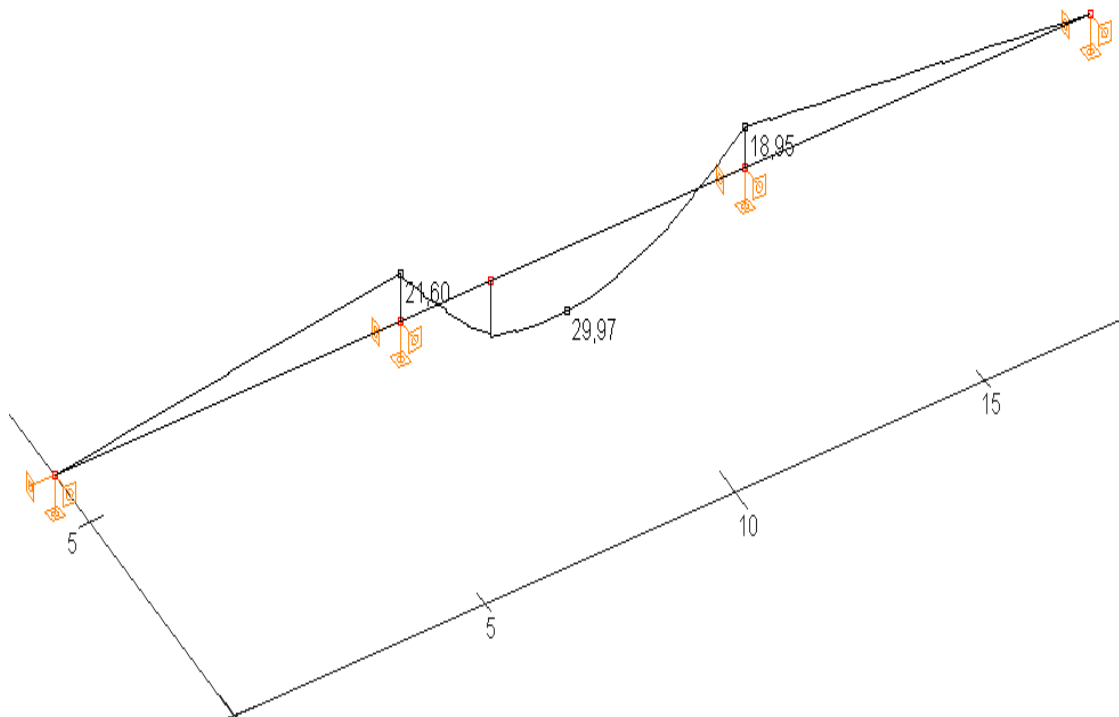

Slika 7.7. Momenti M_z (kNm)

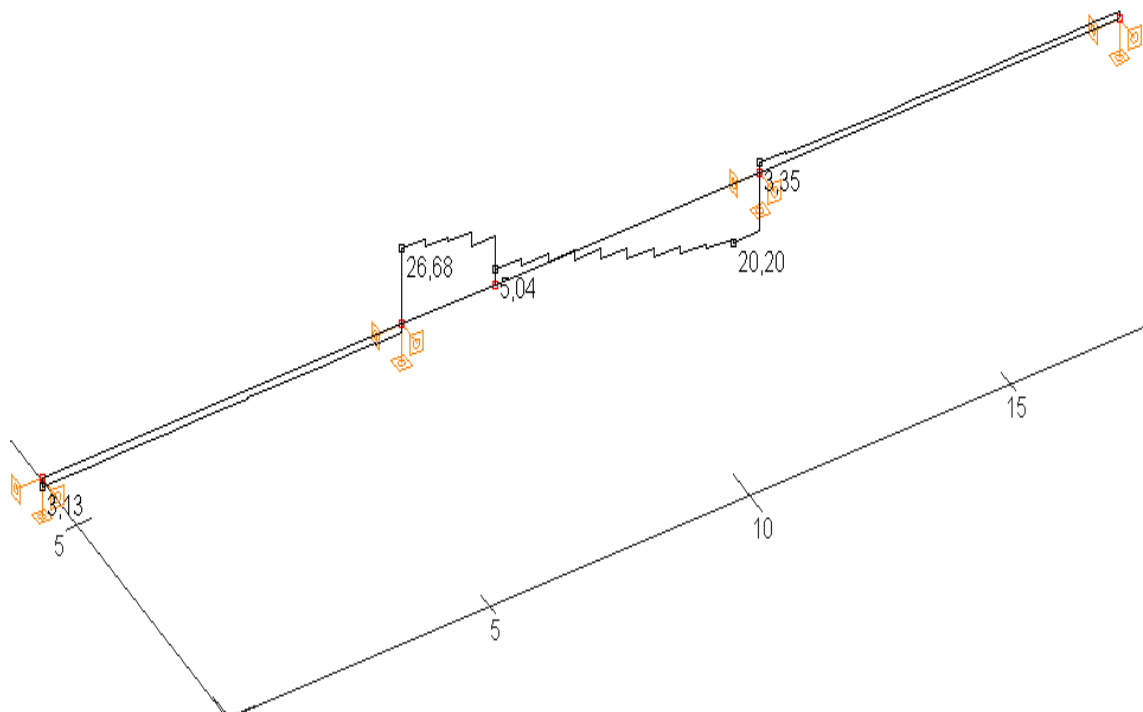

Slika 7.8. Poprečne sile V_y (kN)

7.1.5. Uporabno opterećenje shema 6 (max sile na ležaju)

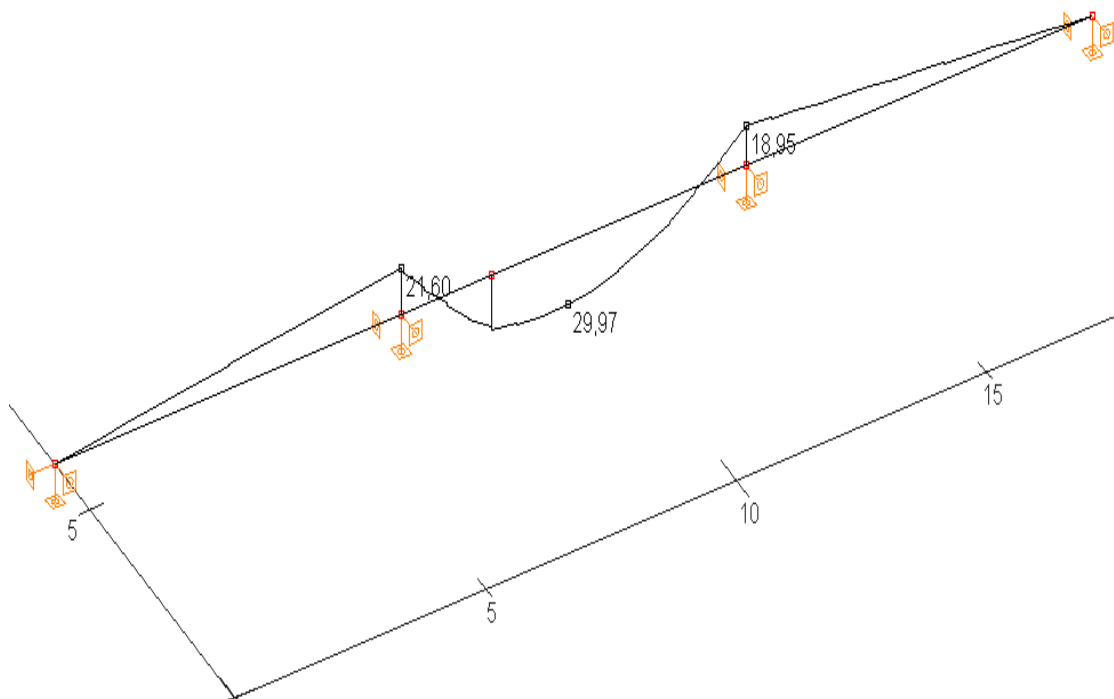

Slika 7.9. Momenti M_z (kNm)

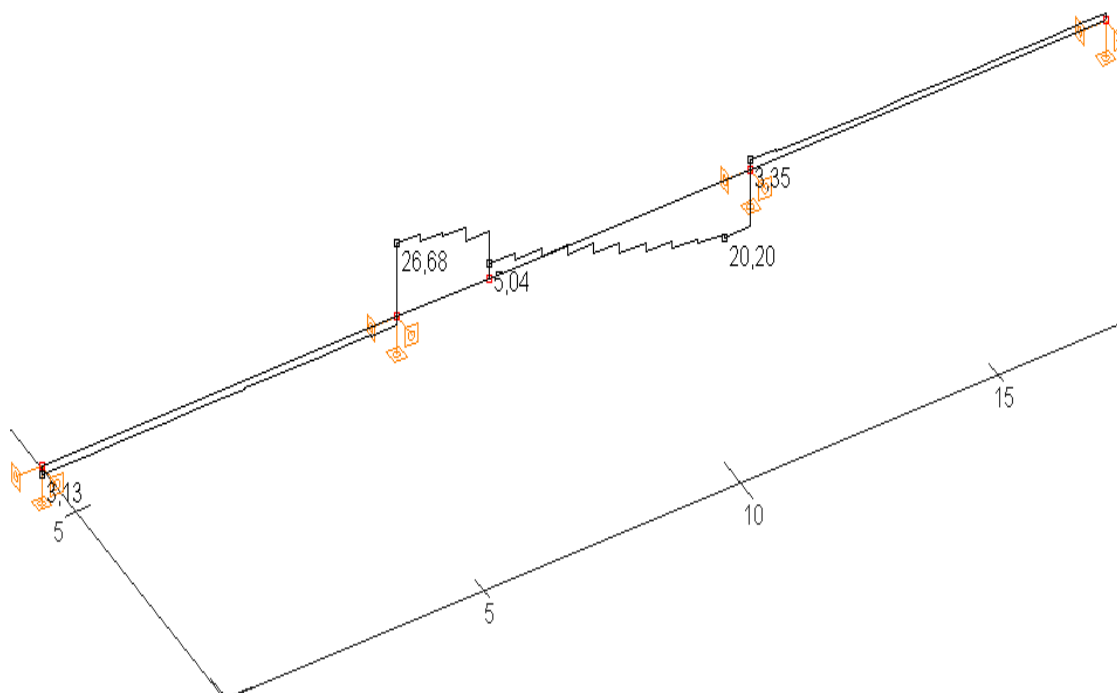

Slika 7.10. Poprečne sile V_y (kN)

7.1.6. GSN za kranjapolja

Mjerodavna kombinacija za proračun GSN: $M_{ed}=1,35*(M_g+M_{\Delta g})+1,5*M_q$

Momenti:

$$M_{Ed, krajnje polje} = 293.93 \text{ kNm}$$

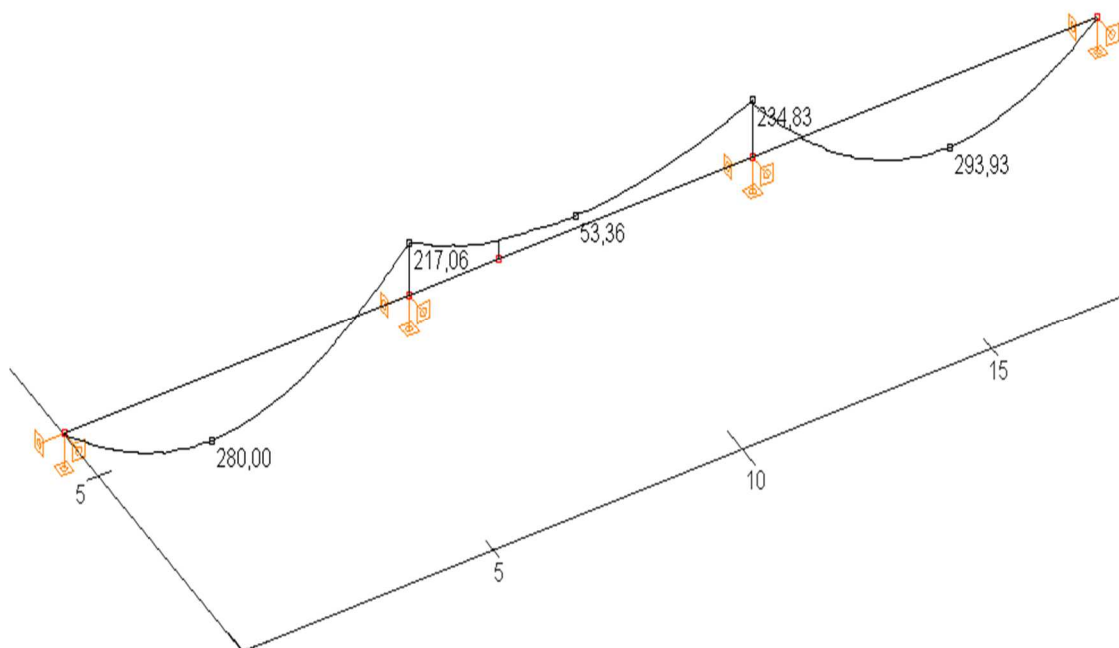

Slika 7.11. Momenti M_z (kNm)

Poprečne sile:

$$V_{Ed, ležaj0} = 154,12 \text{ kN}$$

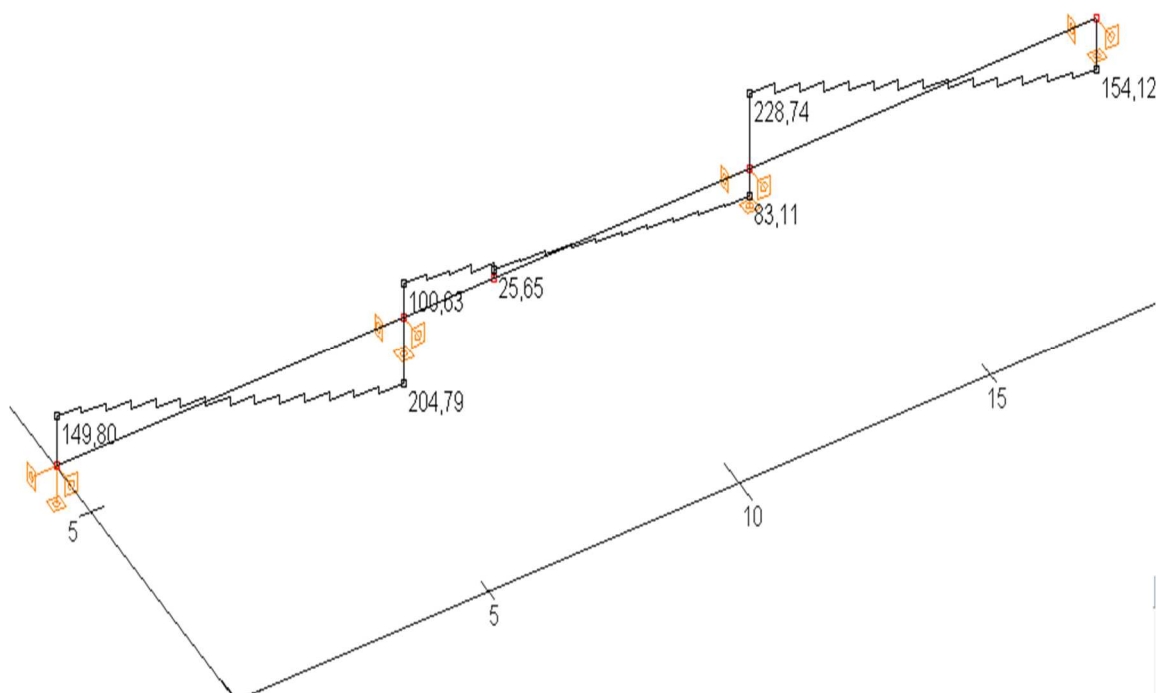

Slika 7.12. Poprečne sile V_y (kN)

7.1.7. GSN za srednje polje

$$M_{Ed, \text{srednja polje}} = 42.57 \text{ kNm}$$

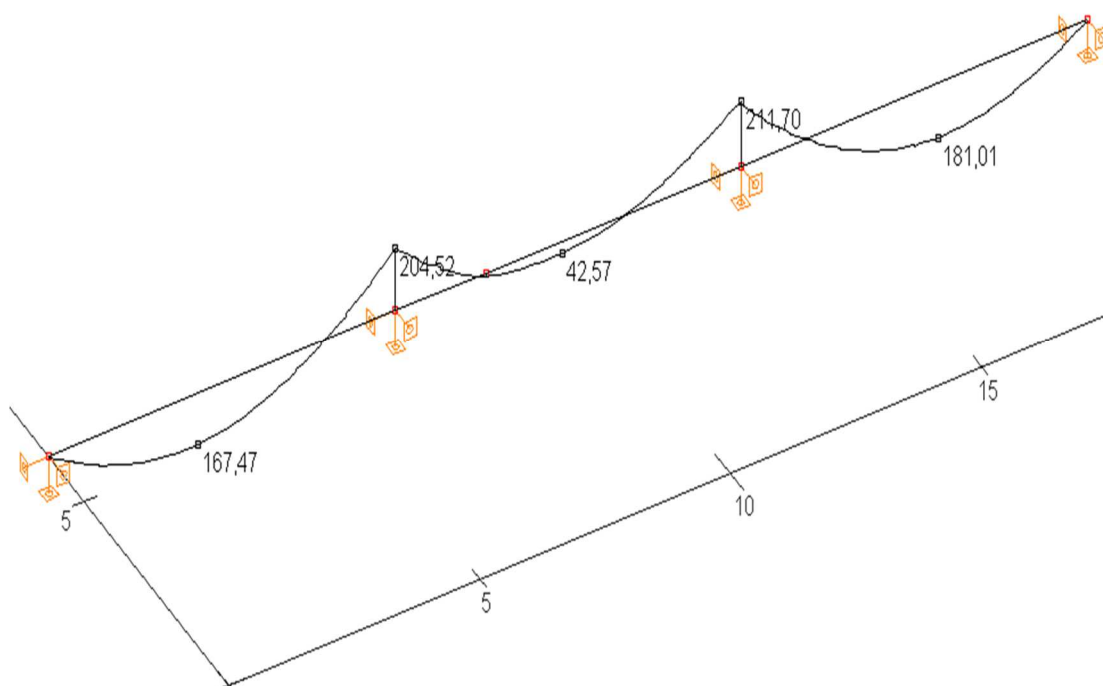

Slika 7.13. Momenti M_z (kNm)

Poprečne sile:

$$V_{Ed, \text{ležaj}} = 167,96 \text{ kN}$$

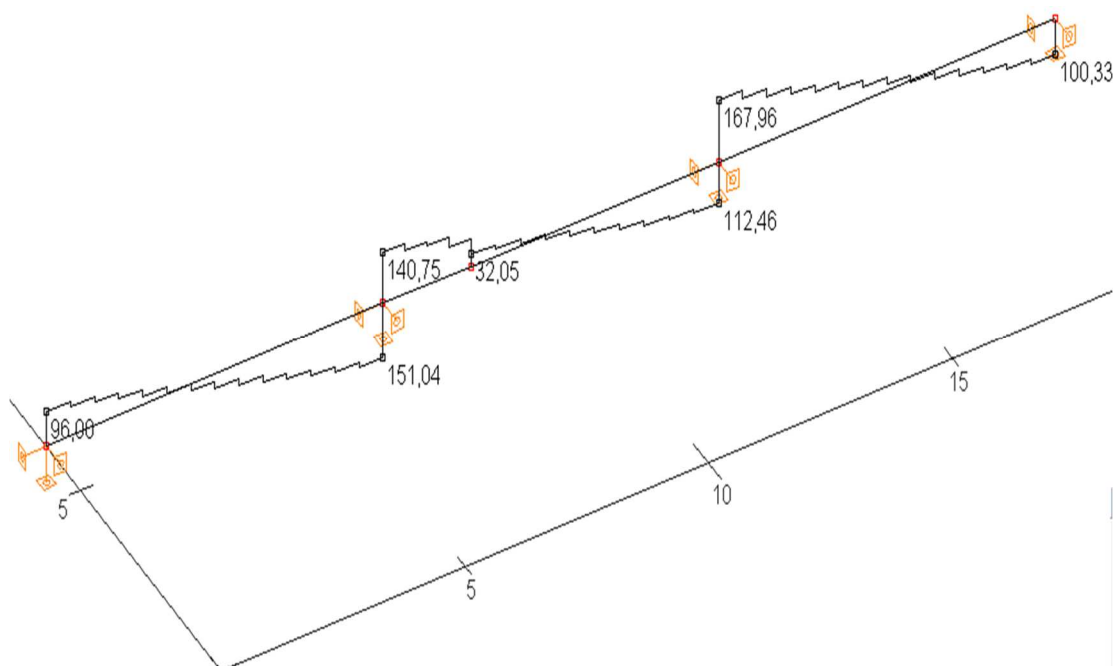

Slika 7.14. Poprečne sile V_y (kN)

7.1.8. GSN za ležaj

Momenti:

$$M_{Ed,ležaj} = -283.29 \text{ kNm}$$

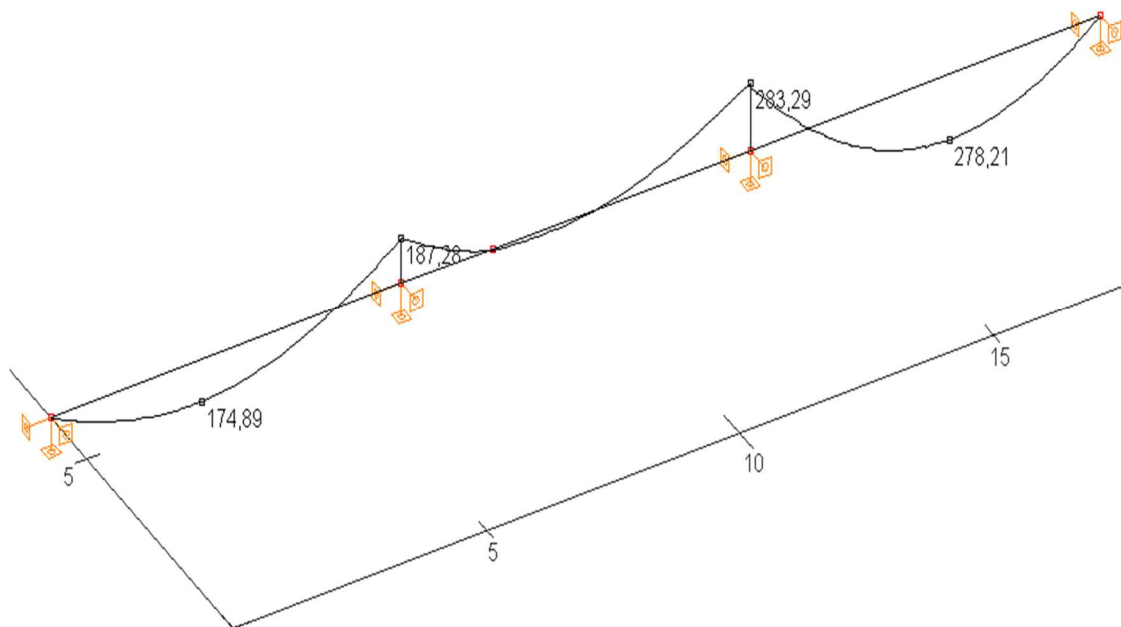

Slika 7.15. Momenti M_z (kNm)

Poprečne sile:

$$V_{Ed,ležaj1} = 240,71 \text{ kN}$$

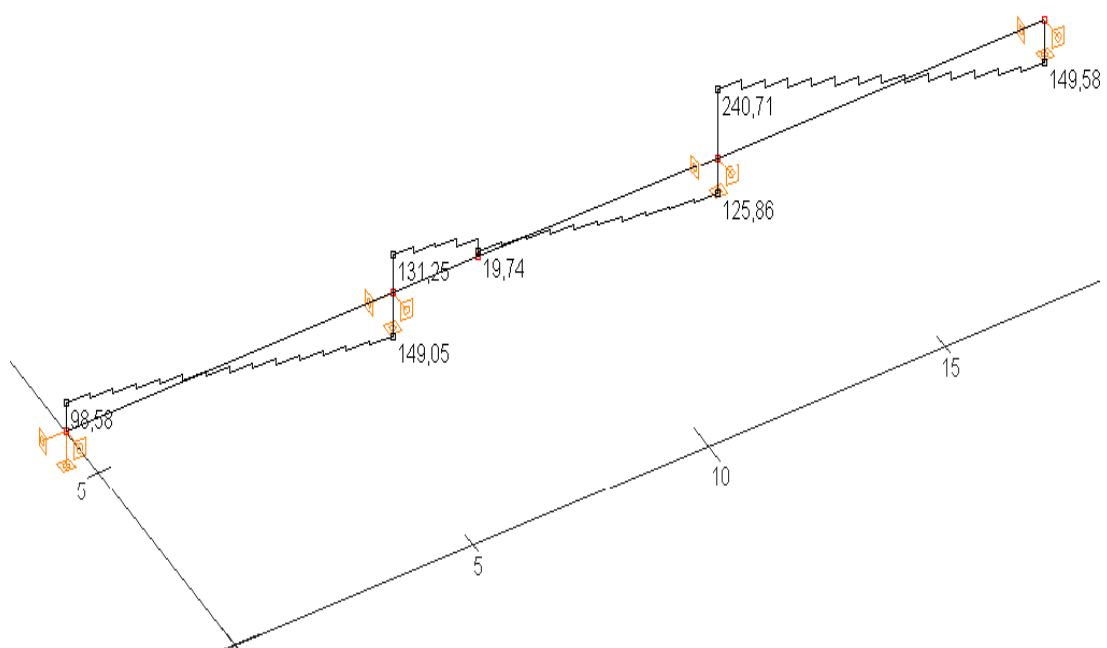

Slika 7.16. Poprečne sile V_y (kN)

7.2. DIMENZIONIRANJE GREDE NA MOMENT SAVIJANJA

BETON:C 40/50;

$$f_{ck} = 40,0 \text{ MPa} = 40 \text{ N/mm}^2 ; \gamma_c = 1,5$$

$$f_{cd} = f_{ck}/\gamma_c = 40,0/1,5 = 26,67 \text{ MPa} = 26.67 \text{ N/mm}^2 = 2,67 \text{ kN/cm}^2$$

ARMATURA:B 500 B;

$$f_{yk} = 500,0 \text{ MPa} = 500 \text{ N/mm}^2 ; \gamma_s = 1,15$$

$$f_{yd} = f_{yk}/\gamma_s = 500,0/1,15 = 434,78 \text{ MPa} = 434.78 \text{ N/mm}^2 = 43.48 \text{ kN/cm}^2$$

Krajnje polje:

Utjecajna širina: $b_{eff} = b_0 + \frac{l_0}{5} \Rightarrow b_{eff} = 30 + \frac{0.85 \cdot 690}{5} = 147.3 \text{ cm}$

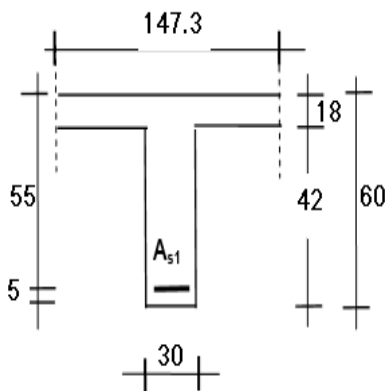

$$M_{Ed} = 293.93 \text{ kNm}$$

$$\mu_{sd} = \frac{M_{Ed}}{b_{eff} \cdot d^2 \cdot f_{cd}} = \frac{29393}{147.3 \cdot 55^2 \cdot 2.67} = 0.025$$

Očitano:

$$\varepsilon_{s1} = 10.0\% \quad \varepsilon_{c2} = 0.9\% \quad \xi = 0.083 \quad \zeta = 0.971$$

$$x = \xi \cdot d = 0.074 \cdot 63 = 4.662 \text{ cm} < h_{pl} = 18 \text{ cm}$$

$$A_{s1} = \frac{M_{Ed}}{\zeta \cdot d \cdot f_{yd}} = \frac{29393}{0.971 \cdot 55 \cdot 43.48} = 12.66 \text{ cm}^2$$

$$d_1 = 5 \text{ cm}$$

$$d = h - d_1 = 60 - 5 = 55 \text{ cm}$$

Odabrano 6Ø18 (As=15.27 cm²)

Ležaj 1:

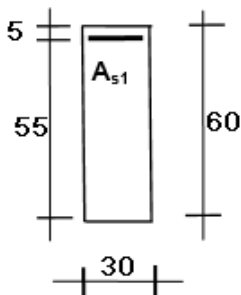

$$M_{Ed} = -283.29 \text{ kNm}$$

$$\mu_{sd} = \frac{M_{Ed}}{b_w \cdot d^2 \cdot f_{cd}} = \frac{28329}{30 \cdot 55^2 \cdot 2.67} = 0.117$$

Očitano:

$$\varepsilon_{s1} = 10.0\% \quad \varepsilon_{c2} = 2.6\% \quad \xi = 0.206 \quad \zeta = 0.919$$

$$x = \xi \cdot d = 0.206 \cdot 55 = 11.33 \text{ cm}$$

$$A_{s1} = \frac{M_{Ed}}{\zeta \cdot d \cdot f_{yd}} = \frac{28329}{0.919 \cdot 55 \cdot 43.48} = 12.90 \text{ cm}^2$$

$$d_1 = 5 \text{ cm}$$

$$d = h - d_1 = 60 - 5 = 55 \text{ cm}$$

Odabrano 6Ø18 (As=15.27 cm²)

Srednje polje – pozitivni moment:

$$\text{Utjecajna širina: } b_{eff} = b_0 + \frac{l_0}{5} \Rightarrow b_{eff} = 30 + \frac{0.70 \cdot 690}{5} = 126.6 \text{ cm}$$

$$d_1 = 5 \text{ cm}$$

$$d = h - d_1 = 60 - 5 = 55 \text{ cm}$$

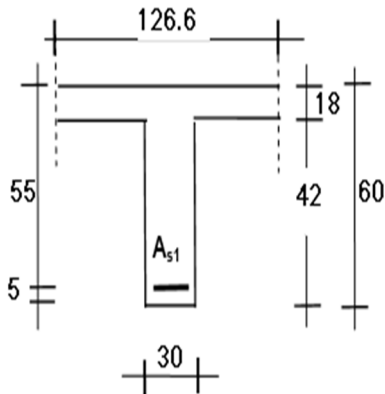

$$M_{Ed} = 42.57 \text{ kNm}$$

$$\mu_{sd} = \frac{M_{Ed}}{b_{eff} \cdot d^2 \cdot f_{cd}} = \frac{4257}{126.6 \cdot 55^2 \cdot 2.67} = 0.004$$

Očitano:

$$\varepsilon_{s1} = 10.0\text{‰} \quad \varepsilon_{c2} = 0.4\text{‰} \quad \xi = 0.038 \quad \zeta = 0.987$$

$$x = \xi \cdot d = 0.038 \cdot 55 = 2.09 \text{ cm} < h_{pl} = 18 \text{ cm}$$

$$A_{s1} = \frac{M_{Ed}}{\zeta \cdot d \cdot f_{yd}} = \frac{4257}{0.987 \cdot 55 \cdot 43.48} = 1.8 \text{ cm}^2$$

Odabrano 2Ø18 ($A_s = 5.09 \text{ cm}^2$)

Minimalna armatura:

$$A_{s1, \min} \geq 0,26 \cdot [f_{ct,m} / f_{yk}] \cdot b_t \cdot d \geq 0,0013 \cdot b_t \cdot d$$

b_t – širina vlačne zone

d – statička visina presjeka

f_{yk} – karakt. granica popuštanja čelika u N/mm²

[$f_{yk} = 500 \text{ N/mm}^2$ za čelik B 500B]

$f_{ct,m}$ - srednja vlačna čvrstoća betona (iz tablice)

[$f_{ct,m} = 3.5 \text{ N/mm}^2$ za C 40/50]

$$A_{s1, \min} \geq 0,26 \cdot 3.5 / 500 \cdot 30 \cdot 55 = 3.00 \text{ cm}^2$$

$$A_{s1, \min} \geq 0,0013 \cdot b_t \cdot d = 0,0013 \cdot 30 \cdot 55 = 2.145 \text{ cm}^2$$

Maksimalna armatura:

$$A_{s1, \max} = 0.04 \cdot A_c = 0.04 \cdot 30 \cdot 60 = 72 \text{ cm}^2$$

7.3. DIMENZIONIRANJE GREDE NA POPREČNU SILU

Ležaj 1

C 40/50

$V_{Ed} = 240.71 \text{ kN}$

$N_{Ed} = 0.0 \text{ kN}$

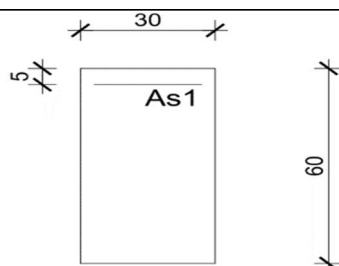

$$As1 = 6\phi 18 = 15.27 \text{ cm}^2$$

$$V_{Rdc} = \left[C_{Rdc} \cdot k \cdot (100 \cdot \rho_l \cdot f_{ck})^{\frac{1}{3}} + k_1 \cdot \sigma_{cp} \right] \cdot b_w \cdot d$$

$$b_w = 30 \text{ cm} ; \quad d = 55 \text{ cm}$$

$$k = 1 + \sqrt{\frac{200}{d}} = 1 + \sqrt{\frac{200}{550}} = 1.60 \leq 2$$

$$k_1 = 0.15$$

$$\sigma_{cp} = \frac{N_{sd}}{A_c} = 0.0$$

$$\Sigma A_s = 6\phi 18 = 15.27 \text{ cm}^2$$

$$\rho_l = \frac{\Sigma A_s}{A_c} = \frac{6\phi 18}{30 \cdot 55} = \frac{15.27}{1650} = 0.0093$$

$$C_{Rdc} = \frac{0.18}{\gamma_c} = \frac{0.18}{1.5} = 0.12$$

$$V_{Rdc} = \left[0.12 \cdot 1.60 \cdot (100 \cdot 0.0093 \cdot 40)^{\frac{1}{3}} \right] \cdot 300 \cdot 550 = 105.75 \text{ kN}$$

$$V_{Rdc} \geq [v_{\min} + k_1 \cdot \sigma_{cp}] \cdot b_w \cdot d$$

$$v_{\min} = 0.035 \cdot k^{\frac{3}{2}} \cdot f_{ck}^{\frac{1}{2}} = 0.035 \cdot 1.60^{\frac{3}{2}} \cdot 40^{\frac{1}{2}} = 0.448$$

$$\sigma_{cp} = \frac{N_{sd}}{A_c} = 0.0$$

$$V_{Rdc} \geq v_{\min} \cdot b_w \cdot d = 0.448 \cdot 300 \cdot 550 = 73.92 \text{ kN} \leq V_{Ed}$$

$$V_{Ed, \max} = V_{Ed} = 240.71 \text{ kN}$$

$$V_{Rd, \max} = 0.5 \cdot v \cdot b_w \cdot d \cdot f_{cd}$$

$$v = 0.6 \cdot \left[1 - \frac{f_{ck}}{250} \right] = 0.6 \cdot \left[1 - \frac{40}{250} \right] = 0.504$$

$$V_{Rd, \max} = 0.5 \cdot 0.504 \cdot 300 \cdot 550 \cdot 26.67 = 1108.94 \text{ kN} > V_{Ed, \max} = V_{Ed}$$

$$V_{Ed, \max} / V_{Rd, \max} = 240.71 / 1108.94 = 0.217 \approx 0.22 \Rightarrow V_{Ed} = 0.22 V_{Rd, \max}$$

$$s_{\max} = \min\{0.75 \cdot d; 30\} = \min\{41,25; 30\} \Rightarrow s_{\max} = 30.0 \text{ cm}$$

$$\rho_{\min} = 0,0013$$

Površina minimalne armature:

$$A_{s_{w,\min}} = \frac{\rho_{\min} \cdot s_w \cdot b_w}{m} = \frac{0.0013 \cdot 30 \cdot 30}{2} = 0.585 \text{ cm}^2$$

Odabrane minimalne spone: **Ø10/30** ($A_{s_w}=0.79 \text{ cm}^2$)

$$f_{y_{w,d}} = \frac{f_{y_k}}{\gamma_s}; B500B \Rightarrow f_{y_{w,d}} = \frac{500}{1.15} = 434.8 \text{ MPa} = 43.48 \text{ kN / cm}^2$$

$$V_{Rd} = V_{Rd,s} = \frac{A_{s_w}}{s} \cdot z \cdot f_{y_{w,d}} \cdot m \cdot \text{ctg} \theta = \frac{0.79}{30} \cdot 0.9 \cdot 55 \cdot 43.48 \cdot 2 \cdot 1$$

$$V_{Rd} = 113.35 \text{ kN}$$

$$V_{Ed} > V_{Rd}$$

Na mjestu maksimalne poprečne sile:

$$s_w \leq \frac{m \cdot A_{s_w} \cdot f_{y_{w,d}} \cdot z}{V_{Ed}} = \frac{2 \cdot 0.79 \cdot 43.48 \cdot 0.9 \cdot 55}{204.71} = 18.46 \text{ cm}$$

Odabrane spone: **Ø10/15cm** ($A_{s_w}=0.79 \text{ cm}^2$)

Ležaj 0

C 40/50

$V_{Ed} = 154.12 \text{ kN}$

$N_{Ed} = 0.0 \text{ kN}$

B

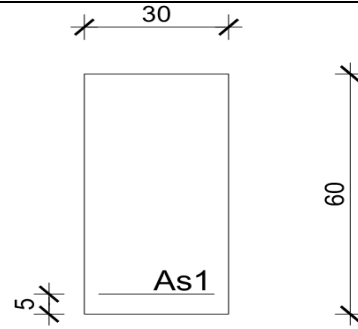

$As1 = 6\phi 18 = 15.27 \text{ cm}^2$

$$V_{Rdc} = \left[C_{Rdc} \cdot k \cdot (100 \cdot \rho_l \cdot f_{ck})^{\frac{1}{3}} + k_1 \cdot \sigma_{cp} \right] \cdot b_w \cdot d$$

$b_w = 30 \text{ cm} ; d = 55 \text{ cm}$

$$k = 1 + \sqrt{\frac{200}{d}} = 1 + \sqrt{\frac{200}{550}} = 1.60 \leq 2$$

$k_1 = 0.15$

$$\sigma_{cp} = \frac{N_{sd}}{A_c} = 0.0$$

$\Sigma A_s = 6\phi 18 = 15.27 \text{ cm}^2$

$$\rho_l = \frac{\Sigma A_s}{A_c} = \frac{6\phi 18}{30 \cdot 55} = \frac{15.27}{1650} = 0.0093$$

$$C_{Rdc} = \frac{0.18}{\gamma_c} = \frac{0.18}{1.5} = 0.12$$

$$V_{Rdc} = \left[0.12 \cdot 1.60 \cdot (100 \cdot 0.0093 \cdot 40)^{\frac{1}{3}} \right] \cdot 300 \cdot 550 = 105.75 \text{ kN}$$

$$V_{Rdc} \geq [v_{\min} + k_1 \cdot \sigma_{cp}] \cdot b_w \cdot d$$

$$v_{\min} = 0.035 \cdot k^{\frac{3}{2}} \cdot f_{ck}^{\frac{1}{2}} = 0.035 \cdot 1.60^{\frac{3}{2}} \cdot 40^{\frac{1}{2}} = 0.448$$

$$\sigma_{cp} = \frac{N_{sd}}{A_c} = 0.0$$

$$V_{Rdc} \geq v_{\min} \cdot b_w \cdot d = 0.448 \cdot 300 \cdot 550 = 73.92 \text{ kN} \leq V_{Ed}$$

$$V_{Ed, \max} = V_{Ed} = 154.12 \text{ kN}$$

$$V_{Rd, \max} = 0.5 \cdot v \cdot b_w \cdot d \cdot f_{cd}$$

$$v = 0.6 \cdot \left[1 - \frac{f_{ck}}{250} \right] = 0.6 \cdot \left[1 - \frac{40}{250} \right] = 0.504$$

$$V_{Rd, \max} = 0.5 \cdot 0.504 \cdot 300 \cdot 550 \cdot 26.67 = 1108.94 \text{ kN} > V_{Ed, \max} = V_{Ed}$$

$$V_{Ed, \max} / V_{Rd, \max} = 154.12 / 1108.94 = 0.139 \approx 0.14 \Rightarrow V_{Ed} = 0.14 V_{Rd, \max}$$

$$s_{\max} = \min\{0.75 \cdot d; 30\} = \min\{41.25; 30\} \Rightarrow s_{\max} = 30.0 \text{ cm}$$

$$\rho_{\min} = 0,0013$$

Površina minimalne armature:

$$A_{s_w, \min} = \frac{\rho_{\min} \cdot s_w \cdot b_w}{m} = \frac{0.0013 \cdot 30 \cdot 30}{2} = 0.585 \text{ cm}^2$$

Odabrane minimalne spone: **Ø10/30** ($A_{s_w}=0.79 \text{ cm}^2$)

$$f_{y_w, d} = \frac{f_{y_k}}{\gamma_s}; B500B \Rightarrow f_{y_w, d} = \frac{500}{1.15} = 434.8 \text{ MPa} = 43.48 \text{ kN / cm}^2$$

$$V_{Rd} = V_{Rd, s} = \frac{A_{s_w}}{s} \cdot z \cdot f_{y_w, d} \cdot m \cdot \text{ctg} \theta = \frac{0.79}{30} \cdot 0.9 \cdot 55 \cdot 43.48 \cdot 2 \cdot 1$$

$$V_{Rd} = 113.35 \text{ kN}$$

$$V_{Ed} > V_{Rd}$$

Na mjestu maksimalne poprečne sile:

$$s_w \leq \frac{m \cdot A_{s_w} \cdot f_{y_w, d} \cdot z}{V_{Ed}} = \frac{2 \cdot 0.79 \cdot 43.48 \cdot 0.9 \cdot 55}{154.12} = 22.06 \text{ cm}$$

Odabrane spone **Ø10/20cm** ($A_{s_w}=0.79 \text{ cm}^2$)

7.4. KONTROLA PUKOTINA GREDE POZICIJE 100

Granično stanje uporabnosti: 1.0 vlastita težina "+" 1.0 dodatno stalno "+" 1.0 uporabno

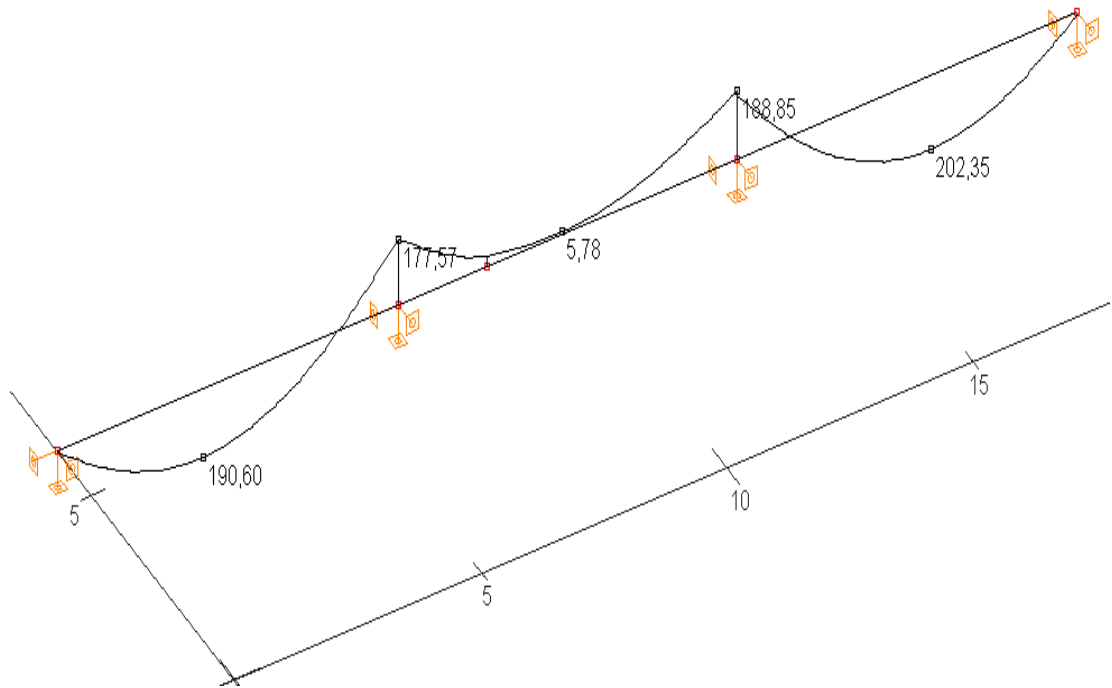

Slika 7.17. Moment (kNm)

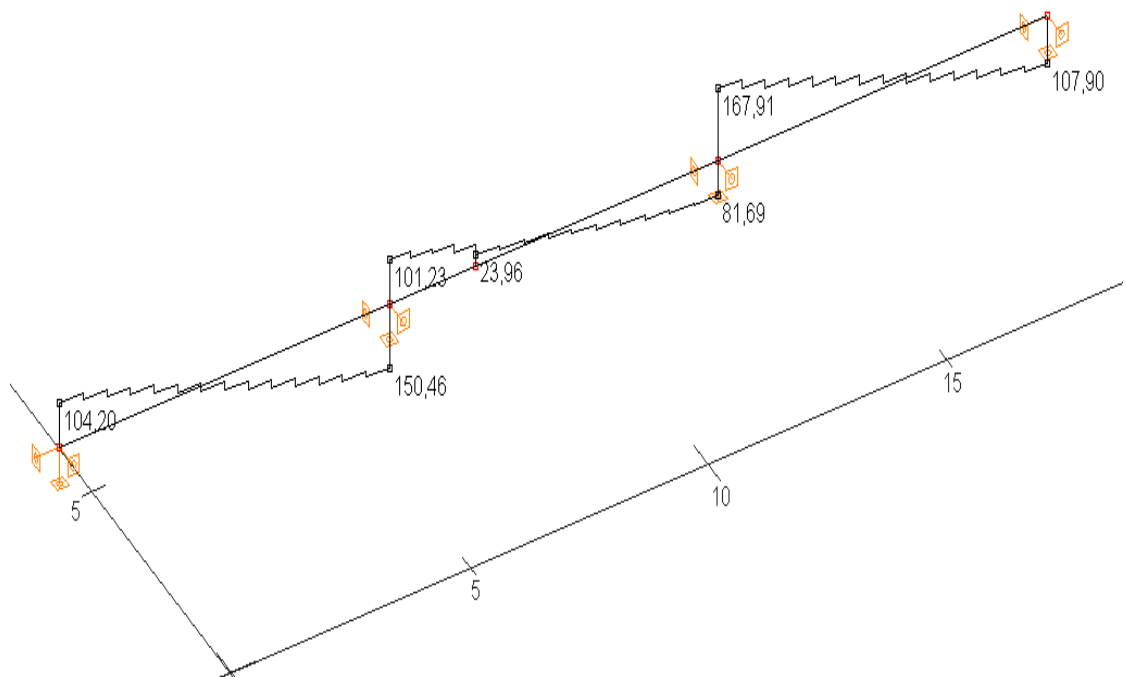

Slika 7.18. Poprečna sila (kN)

Polje:

$$M_{Ed} = 202.35 \text{ kNm}$$

Prognoza širine pukotine:

$$w_k = S_{r,max} \cdot (\varepsilon_{s,m} - \varepsilon_{c,m})$$

Proračun srednje deformacije armature:

$$(\varepsilon_{sm} - \varepsilon_{cm}) = \frac{\sigma_s - k_t \cdot \frac{f_{ct,eff}}{\rho_{p,eff}} \cdot (1 + \alpha_e \cdot \rho_{p,eff})}{E_s} \geq 0.6 \cdot \frac{\sigma_s}{E_s}$$

$$E_{cm} = 35.00 \text{ GPa} = 35000 \text{ MPa} - \text{modul elastičnosti betona}$$

$$E_s = 200.0 \text{ GPa} = 200000.0 \text{ MPa} - \text{modul elastičnosti armature}$$

$$f_{ctm} = 3.5 \text{ MPa} - \text{za betone klase C 40/50}$$

$$k_t = 0.4 - \text{dugotrajno opterećenje}$$

$$\alpha_e = \frac{E_s}{E_{cm}} = \frac{200}{35.0} = 5.71$$

$$x = \frac{\alpha_e \cdot A_{s1}}{b} \cdot \left(-1 + \sqrt{1 + \frac{2 \cdot b \cdot d}{\alpha_e \cdot A_{s1}}} \right) = \frac{5.71 \cdot 15.27}{30} \cdot \left(-1 + \sqrt{1 + \frac{2 \cdot 30 \cdot 55}{5.71 \cdot 15.27}} \right) = 15.21 \text{ cm}$$

$$\sigma_s = \frac{M_{Ed}}{z \cdot A_{s1}} \approx \frac{M_{Ed}}{\left(d - \frac{x}{3} \right) \cdot A_{s1}} = \frac{20235}{\left(55 - \frac{15.21}{3} \right) \cdot 15.27} = 26.54 \text{ kN/cm}^2 = 265.41 \text{ MPa}$$

$$\rho_{p,eff} = \frac{A_{s1}}{A_{c,eff}} = \frac{A_{s1}}{b \cdot 2.5 \cdot d_1} = \frac{15.27}{30 \cdot 2.5 \cdot 5.0} = 0.0407$$

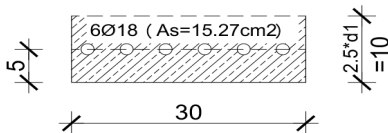

$$(\varepsilon_{sm} - \varepsilon_{cm}) = \frac{265.41 - 0.4 \cdot \frac{3.5}{0.0407} \cdot (1 + 5.71 \cdot 0.0407)}{200000} \geq 0.6 \cdot \frac{265.41}{200000}$$

$$\frac{223.02}{200000} > \frac{159.25}{200000}$$

$$(\varepsilon_{sm} - \varepsilon_{cm}) = 0.00115$$

Proračun srednjeg razmaka pukotina:

$$S_{r,max} = k_3 \cdot c + k_1 \cdot k_2 \cdot k_4 \cdot \frac{\phi}{\rho_{p,eff}}$$

$\phi = 18 \text{ mm}$ – promjer najdeblje šipke

$k_1 = 0.8$ – Rebrasta armatura

$k_2 = 0.5$ – Savijanje

$k_3 = 3.4$

$k_4 = 0.425$

$c = d_1 - \frac{\phi}{2} = 50 - \frac{18}{2} = 41 \text{ mm}$ - zaštitni sloj uzdužne armature

$$S_{r,max} = 3.4 \cdot 41 + 0.8 \cdot 0.5 \cdot 0.425 \cdot \frac{18}{0.0407} = 214.58 \text{ mm}$$

$$W_k = w_k = S_{r,max} \cdot (\varepsilon_{s,m} - \varepsilon_{c,m}) = 214.58 \cdot 0.00115 = 0.247 \text{ mm} < 0.300 \text{ mm}$$

→ pukotine zadovoljavaju

Ležaj:

$$M_{Ed} = 188.85 \text{ kNm}$$

Prognoza širine pukotine:

$$w_k = S_{r,max} \cdot (\varepsilon_{s,m} - \varepsilon_{c,m})$$

Proračun srednje deformacije armature:

$$(\varepsilon_{sm} - \varepsilon_{cm}) = \frac{\sigma_s - k_t \cdot \frac{f_{ct,eff}}{\rho_{p,eff}} \cdot (1 + \alpha_e \cdot \rho_{p,eff})}{E_s} \geq 0.6 \cdot \frac{\sigma_s}{E_s}$$

$E_{cm} = 35.00 \text{ GPa} = 35000 \text{ MPa}$ – modul elastičnosti betona

$E_s = 200.0 \text{ GPa} = 200000.0 \text{ MPa}$ – modul elastičnosti armature

$f_{ctm} = 3.5 \text{ MPa}$ - za betone klase C 40/50

$k_t = 0.4$ - dugotrajno opterećenje

$$\alpha_e = \frac{E_s}{E_{cm}} = \frac{200}{35,0} = 5.71$$

$$x = \frac{\alpha_e \cdot A_{s1}}{b} \cdot \left(-1 + \sqrt{1 + \frac{2 \cdot b \cdot d}{\alpha_e \cdot A_{s1}}} \right) = \frac{5.71 \cdot 15.27}{30} \cdot \left(-1 + \sqrt{1 + \frac{2 \cdot 30 \cdot 55}{5.71 \cdot 15.27}} \right) = 15.21 \text{ cm}$$

$$\sigma_s = \frac{M_{Ed}}{z \cdot A_{s1}} \approx \frac{M_{Ed}}{\left(d - \frac{x}{3} \right) \cdot A_{s1}} = \frac{18885}{\left(55 - \frac{15.21}{3} \right) \cdot 15.27} = 24.769 \text{ kN /cm}^2 = 247.69 \text{ MPa}$$

$$\rho_{p,eff} = \frac{A_{s1}}{A_{c,eff}} = \frac{A_{s1}}{b \cdot 2.5 \cdot d_1} = \frac{15.27}{30 \cdot 2.5 \cdot 5.0} = 0.0407$$

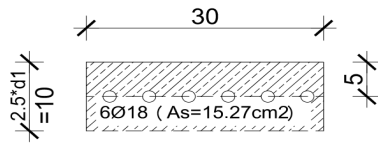

$$(\varepsilon_{sm} - \varepsilon_{cm}) = \frac{247.69 - 0.4 \cdot \frac{3.5}{0.0407} \cdot (1 + 5.71 \cdot 0.0407)}{200000} \geq 0.6 \cdot \frac{247.69}{200000}$$

$$\frac{205.297}{200000} > \frac{148.61}{200000}$$

$$(\varepsilon_{sm} - \varepsilon_{cm}) = 0.001026$$

Proračun srednjeg razmaka pukotina:

$$S_{r,max} = k_3 \cdot c + k_1 \cdot k_2 \cdot k_4 \cdot \frac{\phi}{\rho_{p,eff}}$$

$\phi = 18$ mm – promjer najdeblje šipke

$k_1 = 0.8$ - Rebrasta armatura

$k_2 = 0.5$ – Savijanje

$k_3 = 3.4$

$k_4 = 0.425$

$c = d_1 - \frac{\phi}{2} = 50 - \frac{18}{2} = 41$ mm - zaštitni sloj uzdužne armature

$$S_{r,max} = 3.4 \cdot 41 + 0.8 \cdot 0.5 \cdot 0.425 \cdot \frac{18}{0.0407} = 214.58 \text{ mm}$$

$$W_k = w_k = S_{r,max} \cdot (\varepsilon_{s,m} - \varepsilon_{c,m}) = 214.58 \cdot 0.001026 = 0.220 \text{ mm} \leq 0.300 \text{ mm}$$

→ pukotine zadovoljavaju!

7.5. KONTROLA PROGIBA GREDE POZICIJE 100

Progib kontroliramo za nefaktorizirano opterećenje i bez utjecaja puzanja.

Kontrola progiba za Polje 1:

Granični progib:

$$v_{\text{lim}} = \frac{L}{250} = \frac{690}{250} = 2.76 \text{ cm}$$

Beton: C 40/50; $f_{ck}=40.0 \text{ MPa}$

$$E_{cm} = 35000 \text{ MPa}$$

$$f_{ctm} = 0.3 \cdot (f_{ck})^{2/3} = 0.3 \cdot (40.0)^{2/3} = 3.5 \text{ MPa}$$

Čelik: B500B ; $E_s = 200.0 \text{ GPa}$

$$\alpha_{el} = \frac{E_s}{E_{cm}} = \frac{200.0}{35} = 5.71$$

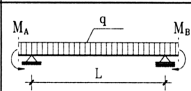
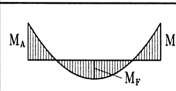
Red	Tip opterećenja	Dijagram momenata savijanja	Koeficijent k iz izraza (5.131)
7			$k = \frac{5}{48} (1 - 0.1\beta)$ $\beta = M_A + M_B / M_F $

$$v_{\text{tot}} = k \cdot L^2 \cdot \frac{1}{r_{\text{tot}}}$$

$$\beta = |M_A + M_B| / |M_F| = |0.0 + 188.85| / |202.35| = 0.933$$

$$k = \frac{5}{48} \cdot (1 - 0.1 \cdot \beta) = 0.104 \cdot (1 - 0.1 \cdot 0.933) = 0.0943$$

Presjek u polju:

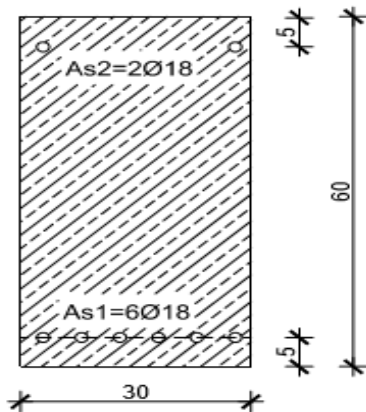

$$A_{s1} = 6\text{Ø}18 = 15.27 \text{ cm}^2$$

$$A_{s2} = 2\text{Ø}18 = 5.09 \text{ cm}^2$$

$$\begin{aligned} I_I &= \frac{bh^3}{12} + \alpha_{el} \cdot \left[A_{s1} \cdot \left(\frac{h}{2} - d_2 \right)^2 + A_{s2} \cdot \left(\frac{h}{2} - d_1 \right)^2 \right] \\ &= \frac{30 \cdot 60^3}{12} + 5.71 \cdot \left[15.27 \cdot \left(\frac{60}{2} - 5 \right)^2 + 5.09 \cdot \left(\frac{60}{2} - 5 \right)^2 \right] = \\ &= 612659.75 \text{ cm}^4 \end{aligned}$$

$$E_{c,eff} = E_{cm} = 35.0 \text{ GN/m}^2 = 3500.0 \text{ kN/cm}^2$$

$$\frac{1}{r_I} = \frac{M_{Ed}}{E_{c,eff} \cdot I_I} = \frac{20235}{3500 \cdot 612659.75} = 0.0000094 \frac{1}{\text{cm}}$$

Progib potpuno raspucanog presjeka:

$$x = 15.21 \text{ cm}$$

$$\begin{aligned} I_{II} &= \frac{bx^3}{12} + bx \cdot \left(\frac{x}{2} \right)^2 + \alpha_{el} \cdot [A_{s1} \cdot (d - x)^2 + A_{s2} \cdot (x - d_2)^2] \\ &= \frac{30 \cdot 15.21^3}{12} + (30 \cdot 15.21) \cdot \left(\frac{15.21}{2} \right)^2 + 5.71 \cdot [15.27 \cdot (55 - 15.21)^2 + 5.09 \cdot (15.21 - 5)^2] \\ &= 176262.92 \text{ cm}^4 \end{aligned}$$

$$\frac{1}{r_{II}} = \frac{M_{Ed}}{E_{c,eff} \cdot I_{II}} = \frac{20235}{3500 \cdot 176262.92} = 0.0000328 \frac{1}{\text{cm}}$$

Ukupni progib:

$$\sigma_s = 265.41 \text{ MPa}$$

$$\sigma_{sr} = \frac{M_{cr}}{\left(d - \frac{x}{3}\right) \cdot A_{s1}}$$

$$M_{cr} = f_{ctm} \cdot W = f_{ctm} \cdot \frac{b \cdot h^2}{6} = 3.5 \cdot \frac{30 \cdot 60^2}{6} = 63000$$

$$\sigma_{sr} = \frac{63000}{\left(55 - \frac{15.21}{3}\right) \cdot 15.27} = 82.63 \text{ MPa}$$

$\beta_1 = 1.0$ - Rebrasta armatura

$\beta_2 = 0.5$ - Dugotrajno opterećenje

$$\zeta = 1 - \beta_1 \cdot \beta_2 \cdot \left(\frac{\sigma_{sr}}{\sigma_s}\right)^2 = 1 - 1.0 \cdot 0.5 \cdot \left(\frac{82.63}{265.41}\right)^2 = 0.952$$

$$\frac{1}{r_I} = 0.0000094 \frac{1}{\text{cm}}$$

$$\frac{1}{r_{II}} = 0.0000328 \frac{1}{\text{cm}}$$

$$\frac{1}{r_m} = (1 - \zeta) \cdot \frac{1}{r_I} + \zeta \cdot \frac{1}{r_{II}} = (1 - 0.952) \cdot 0.0000094 + 0.952 \cdot 0.0000328 = 0.0000317 \frac{1}{\text{cm}}$$

$$k = 0.0943$$

$$L = 690.0 \text{ cm}$$

$$v_{tot, t=0} = k \cdot L^2 \cdot \frac{1}{r_{tot}} = 0.0943 \cdot 690.0^2 \cdot 0.0000317 = 1.42 \text{ cm} < v_{lim} = 2.72 \text{ cm}$$

8. PRORAČUN STUBIŠTA

8.1. MJERODAVNE REZNE SILE

- Moment savijanja mjerodavan za dimenzioniranje stubišta dobiva se iz kombinacije za granično stanje nosivosti na ležajevima pozicije 100.

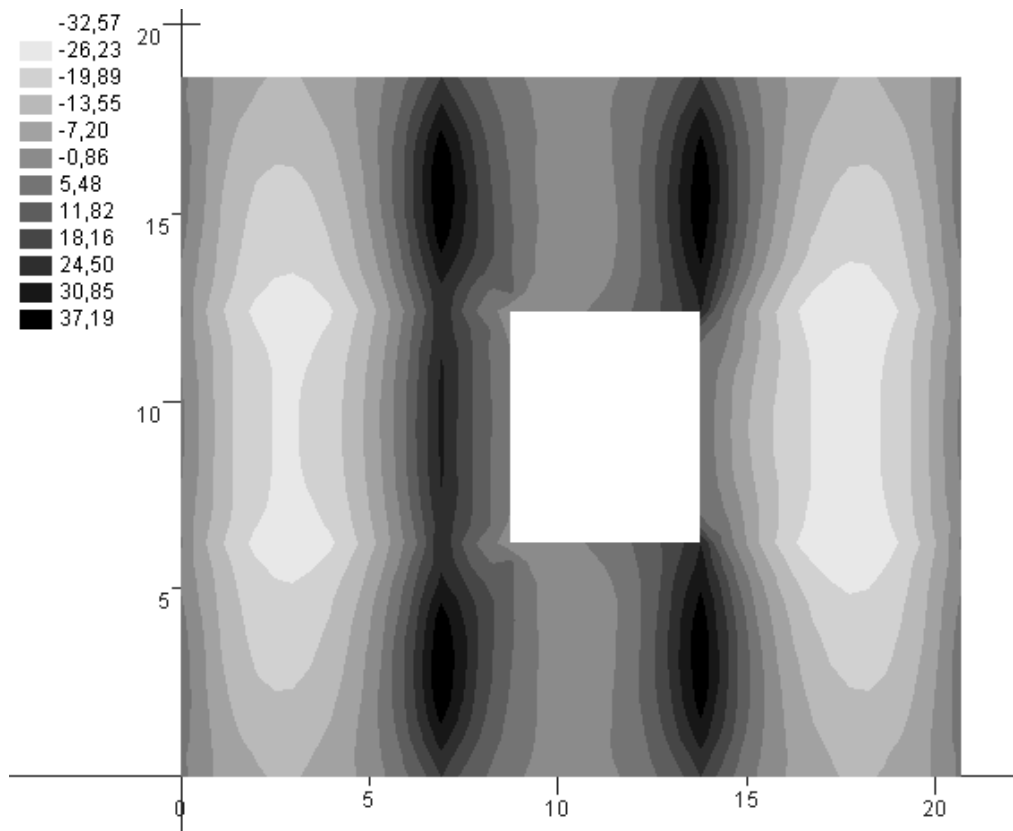

Slika 8.1. Moment M_x (kNm) za GSN na ležajevima pozicije 100

8.2. DIMENZIONIRANJE STUBIŠTA

Polje

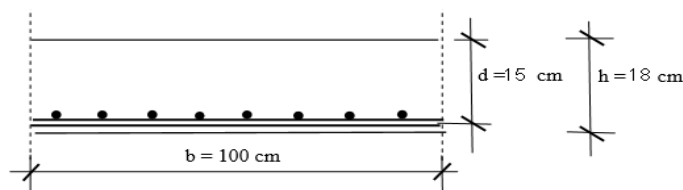

$$M_{Ed} = 24.82 \text{ kNm/m}$$

$$\mu_{sd} = \frac{M_{Ed}}{b \cdot d^2 \cdot f_{cd}} = \frac{2482}{100 \cdot 15^2 \cdot 2.67} = 0.041$$

$$\text{Očitano: } \varepsilon_{s1} = 10.0 \text{ ‰} \quad \varepsilon_{c2} = 1.2 \text{ ‰} \quad \xi = 0.107 \quad \zeta = 0.962$$

$$A_{s1} = \frac{M_{Ed}}{\zeta \cdot d \cdot f_{yd}} = \frac{2482}{0.962 \cdot 15 \cdot 43.48} = 4.00 \text{ cm}^2/\text{m}$$

Odabrana mreža: **R-503** - $A_s = 5.03 \text{ cm}^2/\text{m}$

Ležaj stubište – 105

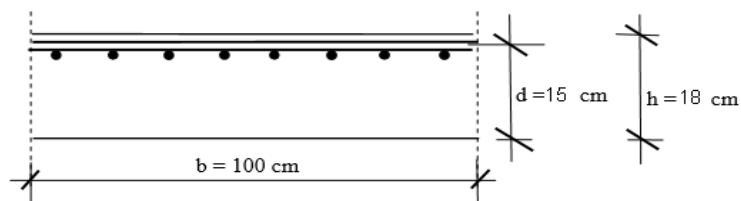

$$M_{Ed} = 29.44 \text{ kNm/m}$$

$$\mu_{sd} = \frac{M_{Ed}}{b \cdot d^2 \cdot f_{cd}} = \frac{2944}{100 \cdot 15^2 \cdot 2.67} = 0.049$$

$$\text{Očitano: } \varepsilon_{s1} = 10.0 \text{ ‰} \quad \varepsilon_{c2} = 1.4 \text{ ‰} \quad \xi = 0.123 \quad \zeta = 0.956$$

$$A_{s1} = \frac{M_{Ed}}{\zeta \cdot d \cdot f_{yd}} = \frac{2944}{0.956 \cdot 15 \cdot 43.48} = 4.72 \text{ cm}^2/\text{m}$$

Odabrana armatura: **R-785** - $A_s = 7.85 \text{ cm}^2/\text{m}$

9. PRORAČUN STUPOVA

9.1. MOMENTI SAVIJANJA I UZDUŽNE SILE STUPOVA

Kombinacije opterećenja s VJETROM :

1. kombinacija opterećenja: $1,35 \cdot (g + \Delta g) + 1,5 \cdot q + 1,5 \cdot W_x$

2. kombinacija opterećenja: $1,35 \cdot (g + \Delta g) + 1,5 \cdot q + 1,5 \cdot W_y$

9.1.1. Kombinacija 1

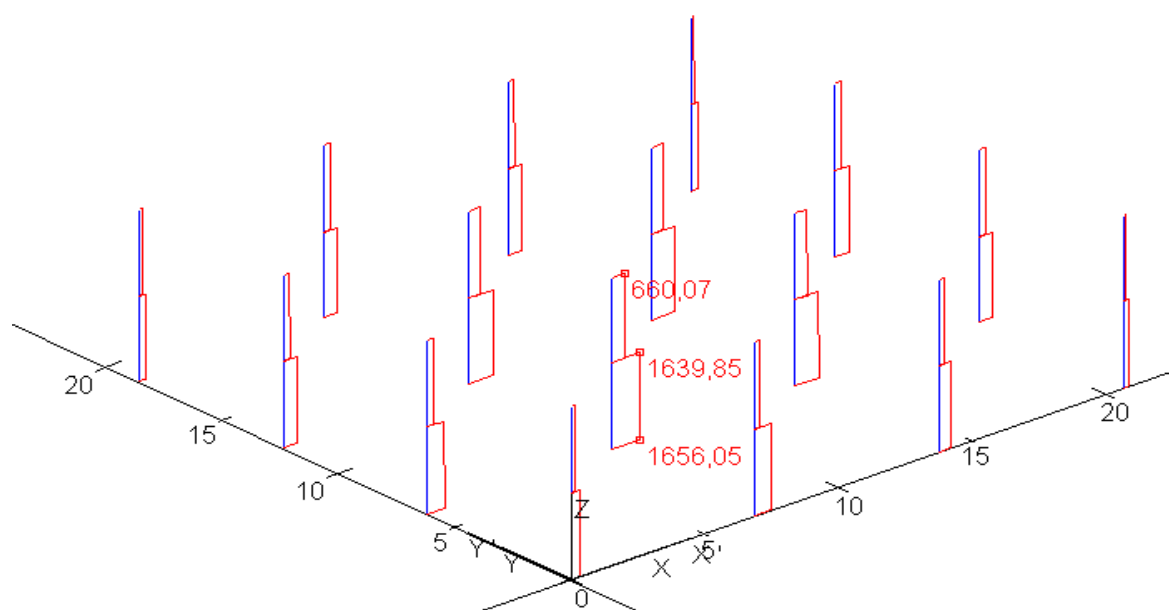

Slika 9.1. Dijagram uzdužnih sila

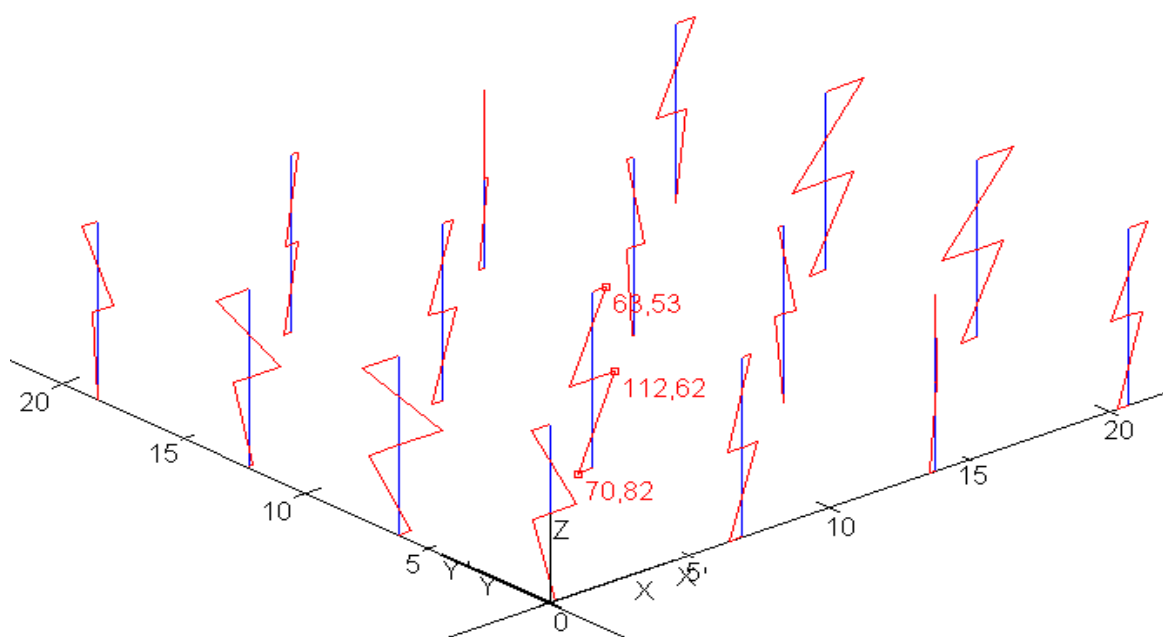

Slika 9.2. Dijagram momenta savijanja

9.1.2. Kombinacija 2

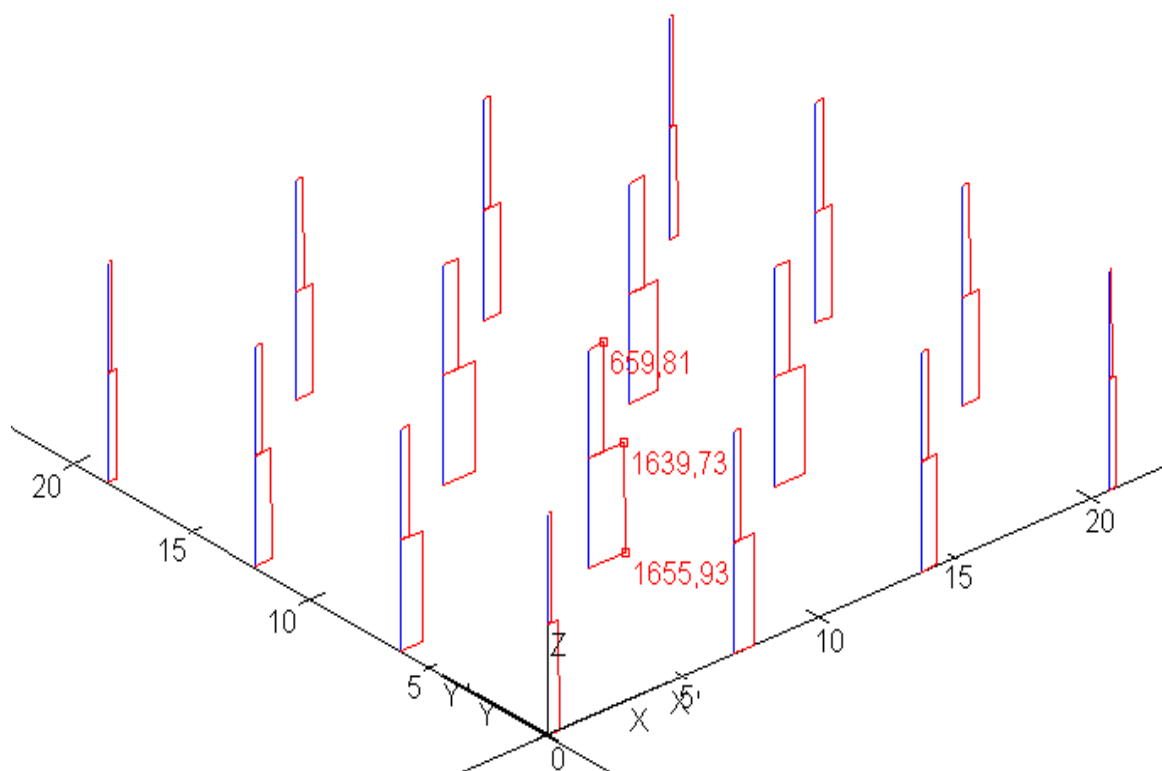

Slika 9.3. Dijagram uzdužnih sila

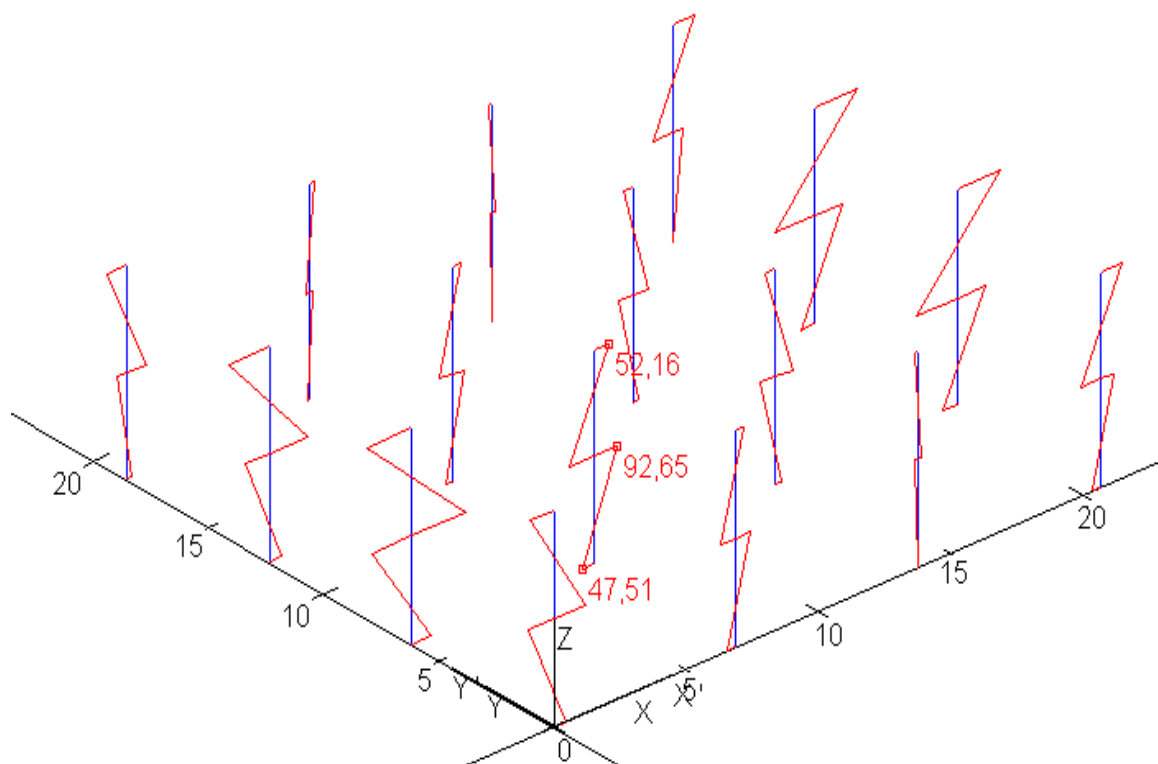

Slika 9.4. Dijagram momenta savijanja

Tablica 9.1. Rezne sile u stupovima

		M(kNm)	N(kN)
1. Kombinacija	MaxN	112.62	-1656.05
2. Kombinacija	Max N	92.65	-1655.93

9.2. DIMENZIONIRANJE STUPA

9.2.1. Određivanje dimenzija stupova

Najnepovoljniji utjecaj je na srednji stup. Vanjske stupove na koje otpada nešto manje vertikalno opterećenje nećemo razmatrati posebno već ćemo sve stupove tretirati kao da su središnji.

$$N_{100} = (\gamma_g \cdot (g_{100} + \Delta g_{100}) + \gamma_q \cdot q_{100}) \cdot L_1 \cdot L_2$$

$$N_{100} = (1.35 \cdot 7.7 + 1.5 \cdot 3.5) \cdot 6.9 \cdot 6.2$$

$$N_{100} = 669.30 \text{ kN}$$

$$N_{200} = (\gamma_g \cdot (g_{200} + \Delta g_{200}) + \gamma_q \cdot q_{200}) \cdot L_1 \cdot L_2$$

$$N_{200} = (1.35 \cdot 8.50 + 1.5 \cdot 1.0) \cdot 6.9 \cdot 6.2$$

$$N_{200} = 555.10 \text{ kN}$$

$$N = 1224.37 \text{ kN}$$

$$\text{Klasa betona: C40/50} \rightarrow f_{cd} = \frac{40}{1.5} = 26.67 \text{ MPa}$$

Radi puzanja naprezanja u betonu ograničavamo na 45% tlačne čvrstoće betona.

$$A_{c,potr} = b \cdot h > (1.35 \cdot N_G + 1.5 \cdot N_Q) / 0.45 \cdot f_{cd} = 1224.37 / 0.45 \cdot 26.67 = 1019 \text{ cm}^2$$

Zbog simetričnosti konstrukcije, a uzimajući u obzir da je stup centrično opterećen, odabiremo kvadratni presjek stupa.

$$a = \sqrt{A} = \sqrt{1019} = 0.3192 \text{ m} = 31.92 \text{ cm}$$

odabrano: $a = 35 \text{ cm}$

9.2.2. Dimenzioniranje pomoću dijagrama interakcije

Rezne sile dobivene u programu *AspalathosLinearsu* po teoriji I. reda.

Tablica 9.2. Rezne sile u stupovima

M(kNm)	N(kN)
112.62	-1656.05
92.65	-1655.93

Pretpostavljamo:

(za $\alpha=1,0$ –simetrična armatura; $\beta=d1/h = d2/h = 5/45=0,1$)

$$v_{sd1} = \frac{N_{Ed1}}{b \cdot h \cdot f_{cd}} = \frac{-1656.05}{35 \cdot 35 \cdot 2.67} = -0,51$$

$$v_{sd2} = \frac{N_{Ed2}}{b \cdot h \cdot f_{cd}} = \frac{-1655.93}{45 \cdot 45 \cdot 2.67} = -0,51$$

$$\mu_{sd1} = \frac{M_{Ed1}}{b \cdot h^2 \cdot f_{cd}} = \frac{112.62 \cdot 100}{35 \cdot 35^2 \cdot 2.67} = 0,10$$

$$\mu_{sd2} = \frac{M_{Ed2}}{b \cdot h^2 \cdot f_{cd}} = \frac{92.65 \cdot 100}{35 \cdot 35^2 \cdot 2.67} = 0,08$$

mehanički koeficijent armiranja $\omega_1 = 0,05$

$$\omega_2 = 0,05$$

$$A_{s1}=A_{s2}=\omega \cdot \frac{f_{cd}}{f_{yd}} \cdot b \cdot h = 0.05 \cdot \frac{2.67}{43.48} \cdot 35 \cdot 35 = 3.76 \text{ cm}^2$$

Ukupna površina armature za simetrično armiranje

$$A_{s1} + A_{s2} = 3.76 \cdot 2 = 7.50 \text{ cm}^2$$

$$A_{s,\min} = 0,1 \cdot N_{Ed} / f_{yd} = 0,1 \cdot 1656 / 43,48 = 3,8 \text{ cm}^2$$

$$A_{s,\min} = 0,002 \cdot A_c = 0,002 \cdot 1225 = 2.45 \text{ cm}^2$$

Odabrane šipke: 4Ø18+4Ø16($A_s=10.18+8.04=18.22 \text{ cm}^2$)

9.2.3. Proračun poprečne armature stupa

Površinu poprečne armature uzima se kao kod greda $\phi 10$ ($A_s = 0.79 \text{ cm}^2$)

Razmak spona:

$$S = \min (b = 45 \text{ cm} ; 15 \times \phi = 15 \times 1.8 = 27 \text{ cm})$$

ODABRANO:

Spone $\phi 10/25 \text{ cm}$

U blizini ležaja razmak spona umanjivamo faktorom 0.6 i razmak iznosi 15 cm.

10. PRORAČUN TEMELJA SAMCA ISPOD STUPA

10.1. DIMENZIONIRANJE TEMELJA

Temelj je proračunat za granično stanje nosivosti. Za dobivanje mjerodavnih naprezanja na spoju stup – temelj korištene su slijedeće kombinacije opterećenja:

$$1,35 \cdot g_{\text{vl.težina}} + 1,35 \cdot g_{\text{dodatno stalno}} + 1,5 \cdot q + 1,5 \cdot w_x$$

$$1,35 \cdot g_{\text{vl.težina}} + 1,35 \cdot g_{\text{dodatno stalno}} + 1,5 \cdot q + 1,5 \cdot w_y$$

Iz navedenih kombinacija dobiveni su parovi maksimalnih uzdužnih sila i pripadnih momenata, te maksimalnih momenata i pripadnih uzdužnih sila od kojih odabiremo dva para sila mjerodavna za dimenzioniranje temelja.

Odabrane mjerodavne sile na spoju:

- 1. kombinacija: $N_{\text{max}} = 1656.05 \text{ kN}$
 $M_{\text{pripadno}} = 112.62 \text{ kNm}$
- 2. kombinacija: $M_{\text{max}} = 92.65 \text{ kNm}$
 $N_{\text{pripadno}} = 1655.93 \text{ kN}$

10.1.1. Preliminarno određivanje dimenzija temelja

Temelj je centrično opterećen zbog čega odabiremo kvadratni poprečni presjek.

Dopuštena naprezanja u tlu (ovise o vrsti tla): $\sigma_{dop} = 0,5 \text{ MN/m}^2$

Širina i duljina temelja: $d = \check{s} = b = a_{stup} \cdot \sqrt{\frac{f_{cd}^*}{\sigma_{t,dop}}} = a_{stup} \cdot \sqrt{\frac{0,45f_{ck}}{\sigma_{t,dop}}} = 0,35 \cdot$

$$\sqrt{\frac{0,45 \cdot 40}{0,50}} = 2,1 \text{ m}$$

Visina temelja: $v = 2 \cdot a_{stup} = 2 \cdot 0,35 = 0,70 \text{ m} = 70 \text{ cm}$

Težina temelja: $N_t = 2,1 \cdot 2,1 \cdot 0,7 \cdot 25 = 77,175 \text{ (kN)}$

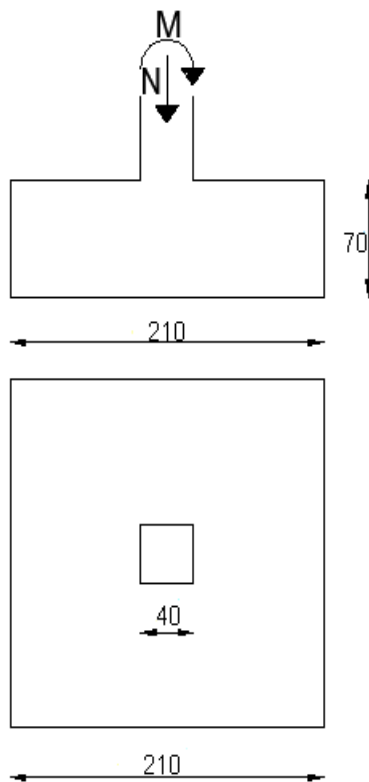

Slika 10.1. Preliminarne dimenzije temelja

10.2. NAPREZANJA NA DODIRNOJ PLOHI TEMELJ – TLO

$$\sigma_{1,2} = \frac{N}{A} \pm \frac{M}{W}$$

$$A = 2,1 \cdot 2,1 = 4,41 \text{ m}^2$$

$$W = \frac{bh^2}{6} = \frac{2,1 \cdot 2,1^2}{6} = 1,54 \text{ m}^3$$

- **1. kombinacija**

$$N_{\max} = 1656,05 \text{ kN} \quad \rightarrow N_{\text{Ed}} = N_{\max} + N_t = 1656,05 + 77,175 = 1733,23 \text{ kN}$$

$$M_{\text{pripadno}} = 112,62 \text{ kNm}$$

$$\sigma_{1,2} = \frac{N}{A} \pm \frac{M}{W} = \frac{1733,23}{4,41} \pm \frac{112,62}{1,54} = 393,00 \pm 73,13$$

$$\sigma_1 = 466,13 \text{ kN/m}^2$$

$$\sigma_2 = 319,87 \text{ kN/m}^2$$

- **2. Kombinacija**

$$M_{\max} = 92,65 \text{ kNm}$$

$$N_{\text{pripadno}} = 1655,93 \text{ kN} \quad \rightarrow N_{\text{Ed}} = N_{\text{prip}} + N_t = 1655,93 + 77,175 = 1733,10 \text{ kN}$$

$$\sigma_{1,2} = \frac{N}{A} \pm \frac{M}{W} = \frac{1733,10}{4,41} \pm \frac{92,65}{1,54} = 393,00 \pm 60,16$$

$$\sigma_1 = 453,16 \frac{\text{kN}}{\text{m}^2}$$

$$\sigma_2 = 332,84 \text{ kN}$$

10.3. PRORAČUN ARMATURE TEMELJA

➤ Momenti u presjeku 1-1

$$M_{1-1} = \sigma_{1-1} \cdot b_1 \cdot \frac{b_1}{2} + (\sigma_1 - \sigma_{1-1}) \cdot \frac{b_1}{2} \cdot \frac{2}{3} \cdot b_1$$

$$\sigma_{1-1} = \sigma_1 - \frac{b_1}{b} \cdot (\sigma_1 - \sigma_2)$$

• 1. kombinacija

$$\sigma_{1-1} = 466.13 - \frac{0.875}{2.10} \cdot (466.16 - 319.87) = 405.18 \text{ kPa}$$

$$M_{1-1} = 405.18 \cdot 0.875 \cdot \frac{0.875}{2} + (466.16 - 405.18) \cdot \frac{0.875}{2} \cdot \frac{2}{3} \cdot 0.875$$

$$M_{1-1} = 170.67 \text{ kNm}$$

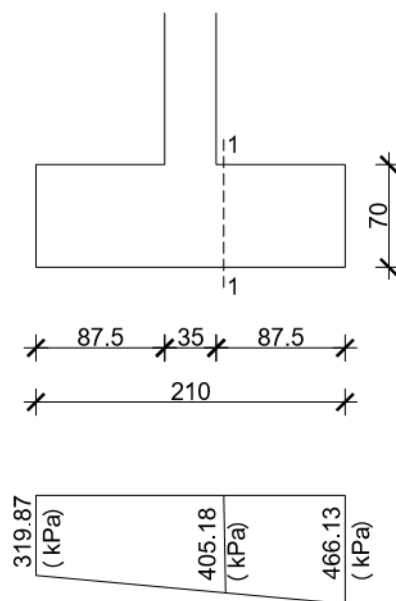

Slika 10.2. Naprezanje ispod temelja za kombinaciju 1

• 2. kombinacija

$$\sigma_{1-1} = 453.16 - \frac{0.875}{2.10} \cdot (453.16 - 332.84) = 403.03 \text{ kPa}$$

$$M_{1-1} = 403.03 \cdot 0.875 \cdot \frac{0.875}{2} + (453.16 - 403.03) \cdot \frac{0.875}{2} \cdot \frac{2}{3} \cdot 0.875$$

$$M_{1-1} = 167.08 \text{ kNm}$$

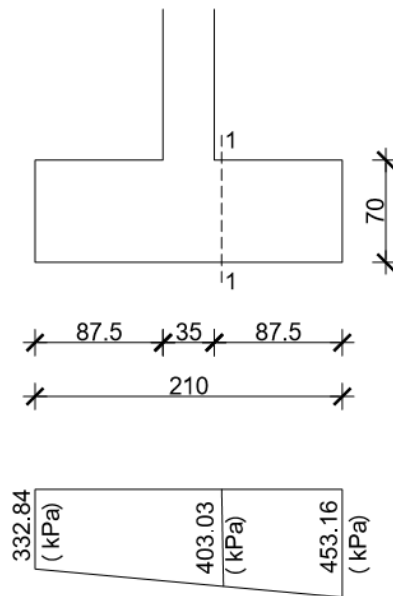

Slika 10.3. Naprezanje ispod temelja za kombinaciju 2

Mjerodavni moment za proračun armature:

$$M_{sd}^{1-1} = 170.67 \text{ kNm}$$

$$\text{Klasa betona: C40/50} \rightarrow f_{ck} = 40 \text{ MPa} \rightarrow f_{cd} = \frac{40}{1.5} = 26.67 \text{ MPa} = 2.67 \text{ kN/cm}^2$$

$$\text{Zadana armatura: B500B} \rightarrow f_{yk} = 500 \text{ MPa} \rightarrow f_{yd} = \frac{500}{1.15} = 434.78 \text{ MPa} = 43.48 \text{ kN/cm}^2$$

$$\mu_{sd} = \frac{M_{ed}}{b \cdot d^2 \cdot f_{cd}} = \frac{170.67 \cdot 100}{100 \cdot 65^2 \cdot 2.67} = 0.015$$

$$\text{Očitano: } \varepsilon_{s1} = 10.0 \text{ ‰, } \varepsilon_{c2} = 0.7 \text{ ‰, } \xi = 0.065, \zeta = 0.977$$

$$A_{s1} = \frac{M_{ed,1-1}}{f_{yd} \cdot \zeta \cdot d} = \frac{170.67 \cdot 100}{43.48 \cdot 0.977 \cdot 65} = 6.18 \text{ cm}^2/\text{m}'$$

$$A_{s1} = \frac{6.18}{2.1} = 2.94 \left(\frac{\text{cm}^2}{\text{m}'} \right)$$

Odabrana armatura:

$$A_{s1, \text{potrebno}} = 2.94 \left(\frac{\text{cm}^2}{\text{m}'} \right)$$

U donju zonu temelja:

Odabrana armatura: mreža Q335 ($A_{s1} = 3.35 \text{ cm}^2/\text{m}$)

Konstruktivna armatura u gornjoj zoni: mreža Q226 ($A_{s1} = 2.26 \text{ cm}^2/\text{m}$)

11. PRILOZI

- 11.1. ARMATURA PLOČE POZICIJA 100- DONJA ZONA**
- 11.2. ARMATURA PLOČE POZICIJA 100- GORNJA ZONA**
- 11.3. ARMATURA PLOČE POZICIJA 200- DONJA ZONA**
- 11.4. ARMATURA PLOČE POZICIJA 200- GORNJA ZONA**
- 11.5. ARMATURNI PLAN GREDE POZICIJE 100**
- 11.6. ARMATURNI PLAN GREDE POZICIJE 200**
- 11.7. ARMATURNI PLAN STUBIŠTA**
- 11.8. ARMATURNI PLAN STUPA**

12. LITERATURA

Radnić J., Harapin A. Osnove betonskih konstrukcija, interna skripta.
Fakultet građevinarstva arhitekture i geodezije Splitu, studeni 2013.

V. Herak Marović: Betonske konstrukcije 2, nastavni tekst (predavanja, vježbe)
<http://cigla.gradst.hr/moodle26/course/view.php?id=151>

V. Herak Marović: Betonske konstrukcije 1, nastavni tekst (predavanja, vježbe)
<http://cigla.gradst.hr/moodle26/course/view.php?id=150>

ARMATURA PLOČE POZICIJA 100 DONJA ZONA MJ 1:100

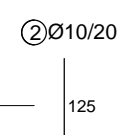
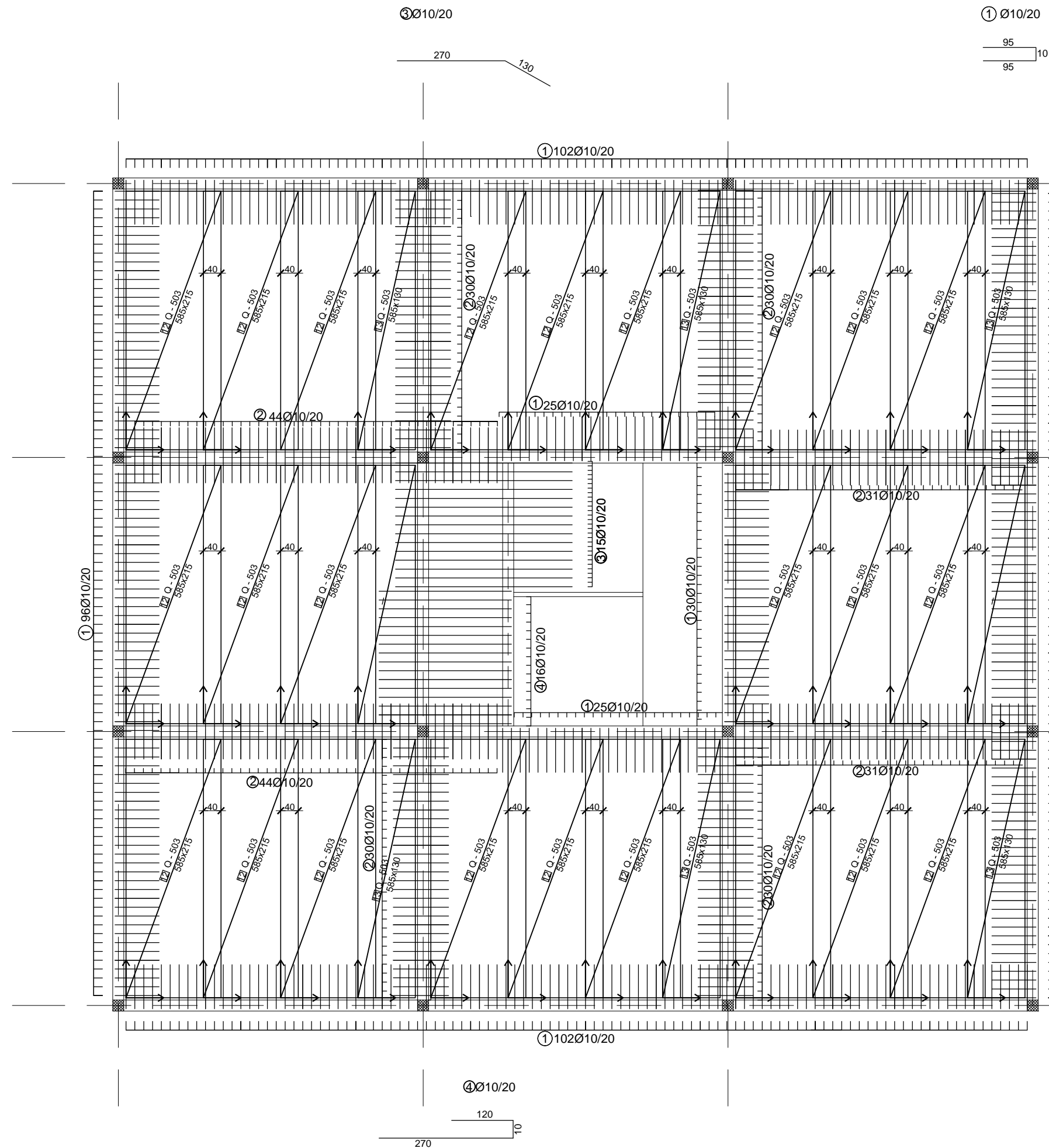

KLASA BETONA:
BETON C 40/50
ARMATURA B500B
PREKLOP MREŽA ≥45 cm
ZAŠTITNI SLOJ C=3 cm

Mreže-specifikacija						
Pozicija	Oznaka mreže	B [cm]	L [cm]	n	Jedinična težina [kg/m ²]	Ukupna težina [kg]
POZICIJE 100 DONJA ZONA						
12	Q-503	215	585	24	8.03	2424.00
13	Q-503	130	585	8	8.03	488.55
Ukupno						2912.55

Šipke specifikacija							
ozn.	oblik i dimenzije [cm]	Ø	lg [m]	n [kom.]	lgn [m]	Jedinična-težina [kg/m ³]	Ukupna težina [kg]
POZICIJE 100 DONJA ZONA							
1		10	2.00	446	892.00	0.79	704.68
2		10	1.25	270	337.50	0.79	266.63
3		10	4.00	15	60.00	0.79	47.40
4		10	4.00	16	64.00	0.79	50.56
Ukupna težina:							1069.00

		SVEUČILIŠTE U SPLITU FAKULTET GRAĐEVINARSTVA, ARHITEKTURE I GEODEZIJE	UNIVERSITY OF SPLIT FACULTY OF CIVIL ENGINEERING, ARCHITECTURE AND GEODESY
ZAVRŠNI RAD			
IZRADIO	ANTE BILOŠ		
AKADEMSKA GODINA 2016/2017			13.3.2017.
ARMATURA POZ.100 DONJA ZONA			M 1:100

ARMATURA PLOČE POZICIJA 100 GORNJA ZONA MJ 1:100

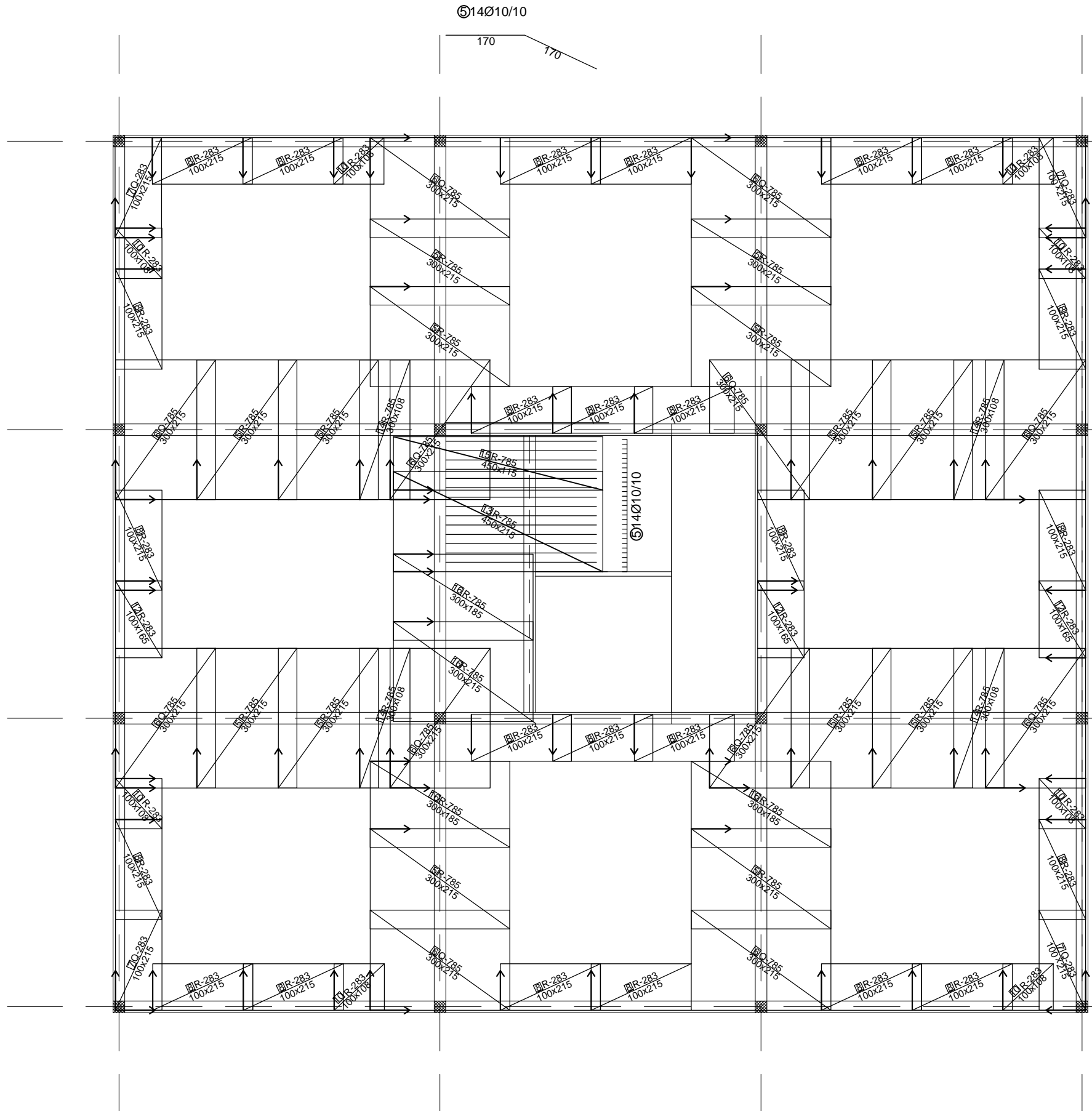

KLASA BETONA:
BETON C 40/50
ARMATURA B500B
PREKLOP MREŽA ≥45 cm
ZAŠTITNI SLOJ C=3 cm

Mreže-specifikacija						
Pozicija	Oznaka mreže	B [cm]	L [cm]	n	Jedinična težina [kg/m ²]	Ukupna težina [kg]
POZICIJE 100 GORNJA ZONA						
5	Q-785	215	300	10	12.46	803.67
6	R-785	215	300	17	7.35	805.93
7	Q-283	215	100	4	4.48	38.53
8	R-283	215	100	25	2.77	148.80
10	R-283	108	100	8	2.77	23.93
12	R-283	165	100	2	2.77	9.14
13	R-785	215	450	1	7.35	71.11
14	R-785	108	300	4	7.35	95.25
15	R-785	115	450	1	7.35	38.00
16	R-785	185	300	1	7.35	40.95
Ukupno						2075.30

Šipke specifikacija							
ozn.	oblik i dimenzije [cm]	Ø	lg [m]	n [kom.]	lgn [m]	Jedinična-težina [kg/m ³]	Ukupna težina [kg]
POZICIJE 100 GORNJA ZONA							
5	170	10	3.40	14	47.60	0.79	37.60
Ukupna težina:							37.60

		SVEUČILIŠTE U SPLITU FAKULTET GRAĐEVINARSTVA, ARHITEKTURE I GEODEZIJE	UNIVERSITY OF SPLIT FACULTY OF CIVIL ENGINEERING, ARCHITECTURE AND GEODESY
ZAVRŠNI RAD			
IZRADIO	ANTE BILOŠ		
AKADEMSKA GODINA 2016/2017			13.3.2017.
ARMATURA POZ.100 GORNJA ZONA			M 1:100

ARMATURA PLOČE POZICIJA 200 DONJA ZONA MJ 1:100

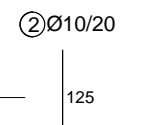
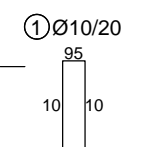
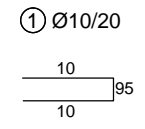
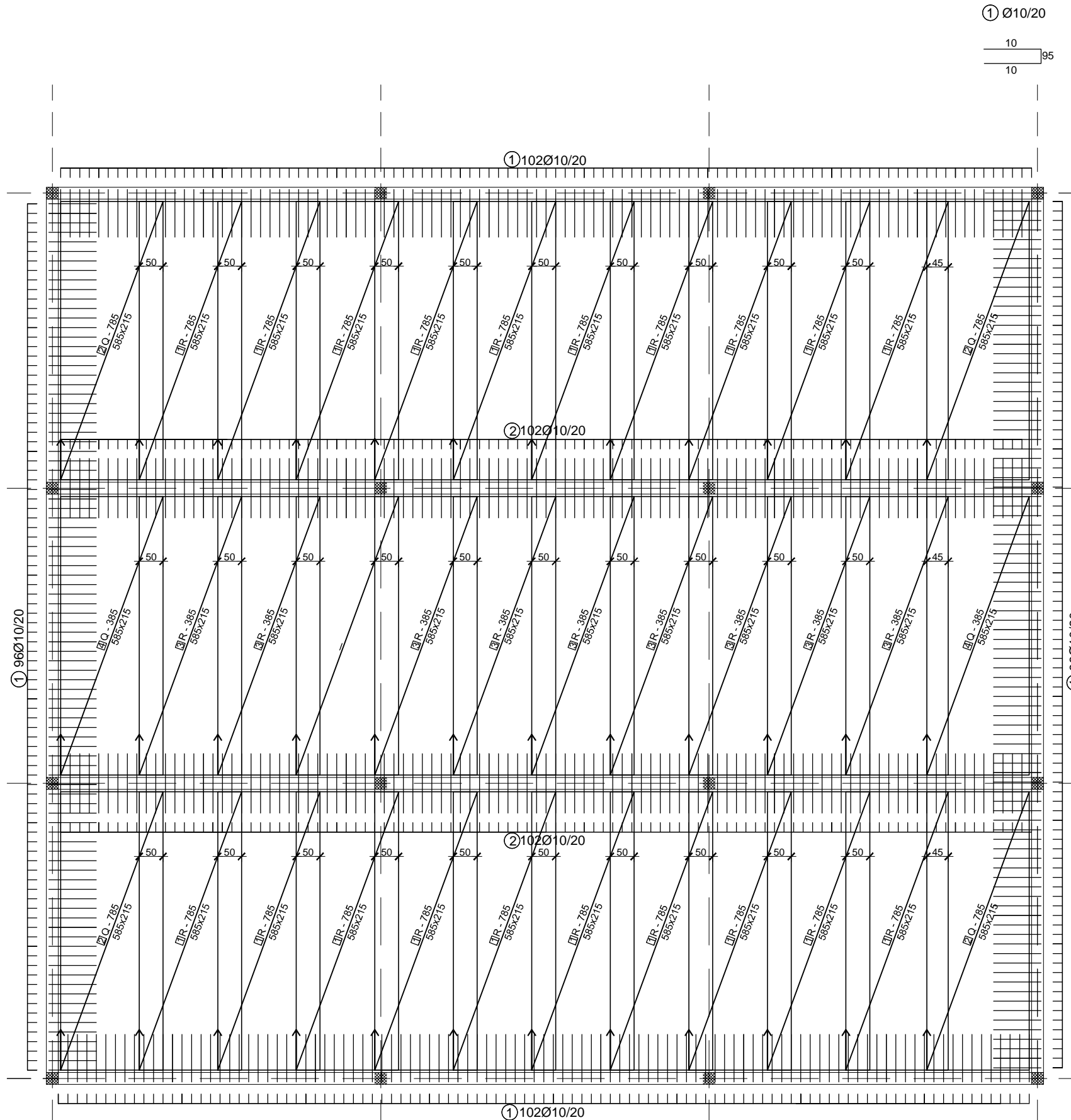

KLASA BETONA:
BETON C 40/50
ARMATURA B500B
PREKLOP MREŽA ≥45 cm
ZAŠTITNI SLOJ C=3 cm

Mreže-specifikacija						
Pozicija	Oznaka mreže	B [cm]	L [cm]	n	Jedinična težina [kg/m ²]	Ukupna težina [kg]
POZICIJE 200 DONJA ZONA						
1	R-785	215	585	20	7.35	1848.90
2	Q-785	215	585	4	12.46	626.86
3	R-385	215	585	10	3.68	462.85
4	Q-385	215	585	2	6.10	153.44
Ukupno						3092.05

Šipke specifikacija							
ozn.	oblik i dimenzije [cm]	Ø	lg [m]	n [kom.]	lgn [m]	Jedinična-težina [kg/m ³]	Ukupna težina [kg]
POZICIJE 200 DONJA ZONA							
1	95	10	2.00	396	792.00	0.79	625.68
2	125	10	1.25	204	255.00	0.79	201.45
Ukupna težina:							827.00

ARMATURA PLOČE POZICIJA 200 GORNJA ZONA MJ 1:100

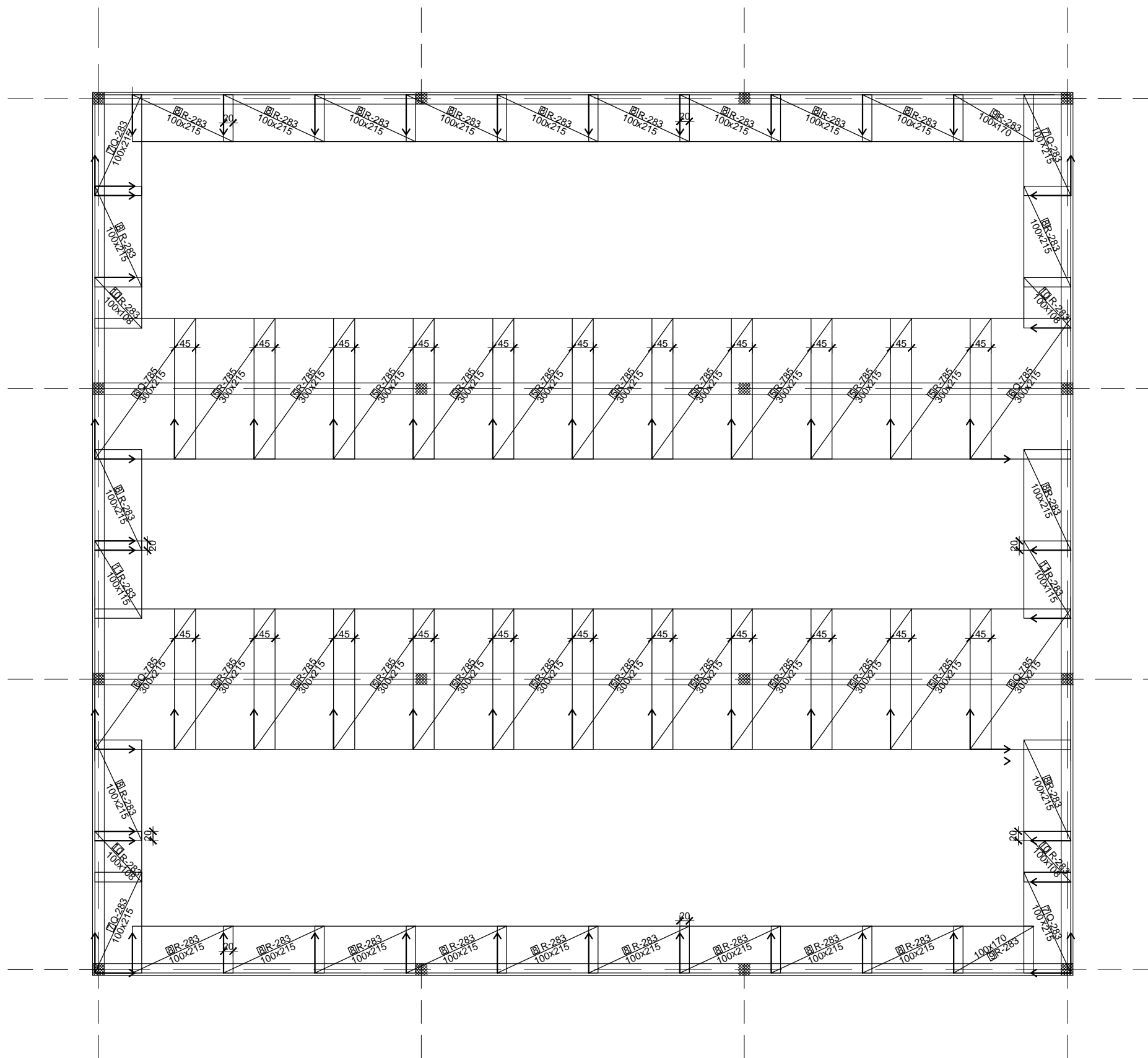

KLASA BETONA:
BETON C 40/50
ARMATURA B500B
PREKLOP MREŽA ≥45 cm
ZAŠTITNI SLOJ C=3 cm

Mreže-specifikacija						
Pozicija	Oznaka mreže	B [cm]	L [cm]	n	Jedinična težina [kg/m ²]	Ukupna težina [kg]
POZICIJA 200 GORNJA ZONA						
5	R-785	215	300	18	7.38	856.82
6	Q-785	215	300	4	12.46	321.50
7	Q-283	215	100	4	4.48	38.53
8	R-283	215	100	23	2.77	136.98
9	R-283	170	100	2	2.77	9.42
10	R-283	108	100	4	2.77	11.97
11	R-283	165	100	2	2.77	9.15
Ukupna težina:						1374.94

		SVEUČILIŠTE U SPLITU FAKULTET GRAĐEVINARSTVA, ARHITEKTURE I GEODEZIJE	UNIVERSITY OF SPLIT FACULTY OF CIVIL ENGINEERING, ARCHITECTURE AND GEODESY
ZAVRŠNI RAD			
IZRADIO		ANTE BILOŠ	
AKADEMSKA GODINA 2016/2017			13.3.2017.
ARMATURA POZ.200 GORNJA ZONA			M 1:100

ARMATURA GREDE POZICIJA 100

MJ 1:65

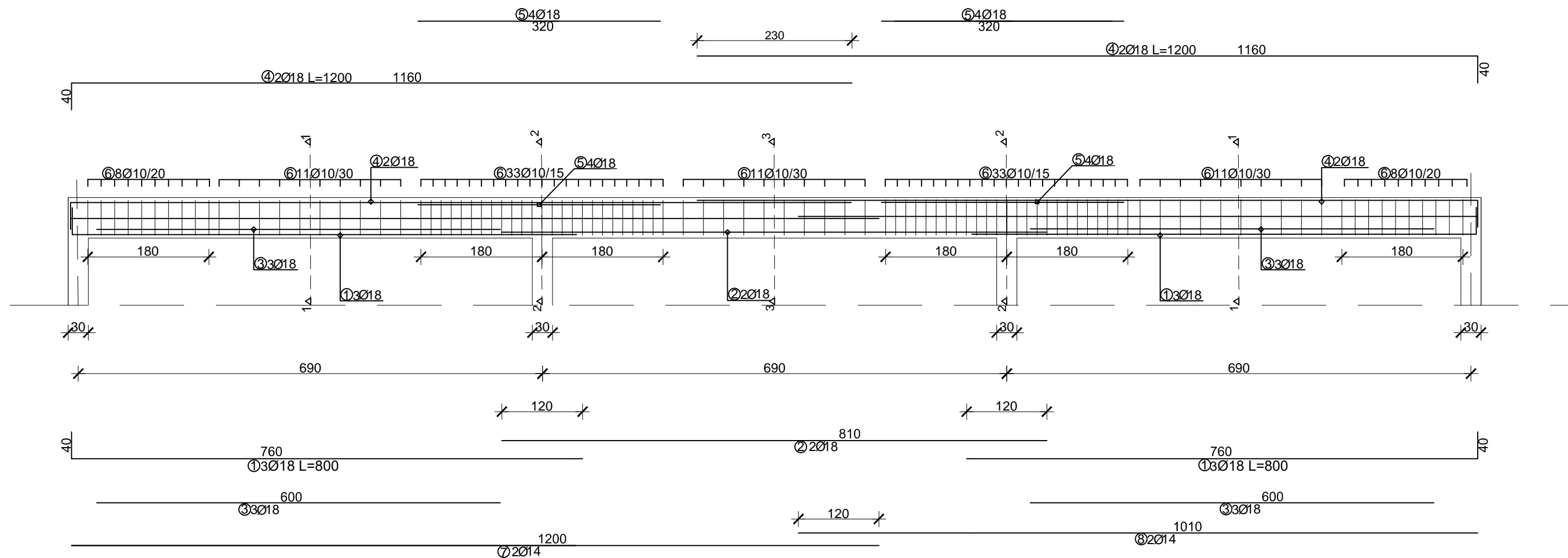

1-1
1:25

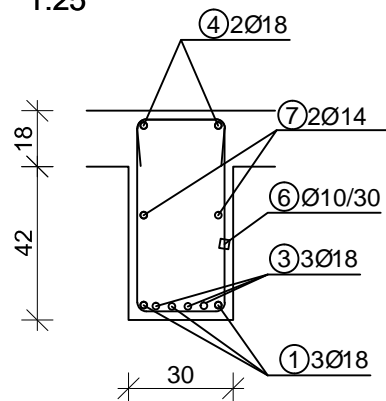

3-3
1:25

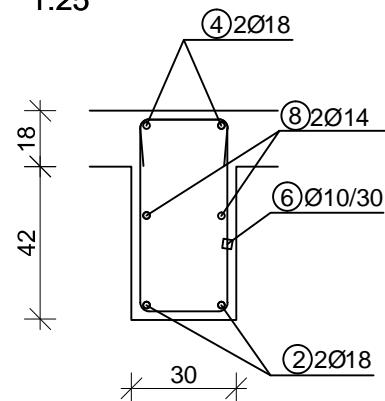

2-2
1:25

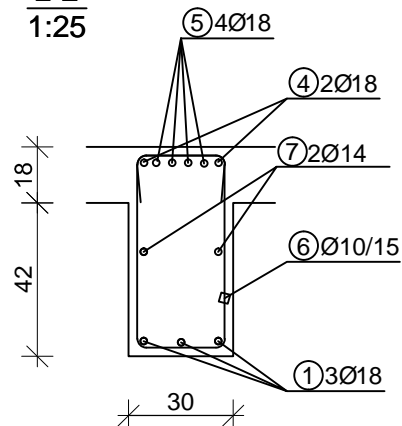

6) Ø10/15/20/30 L=182 cm

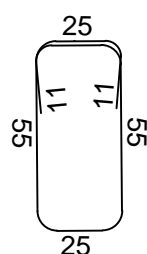

Šipke specifikacija							
ozn.	oblik i dimenzije [cm]	Ø	lg [m]	n [kom.]	lgn [m]	Jedinična-težina [kg/m ³]	Ukupna težina [kg]
1	40 760	18	8.00	6	48.00	1.998	95.90
2	810	18	8.10	2	16.20	1.998	32.37
3	600	18	6.00	6	36.00	1.998	71.93
4	40 1160	18	12.00	4	48.00	1.998	95.90
5	360	18	3.60	8	28.8	1.998	57.54
6	25 55 11 11 55	10	1.82	100	167.44	0.79	143.78
7	1200	14	12.00	2	24.00	1.208	29.00
8	1010	14	10.10	2	20.20	1.208	26.82
Ukupna težina:							553.24 [kg]

KLASA BETONA:
BETON C 40/50
ARMATURA B500B
ZAŠTITNI SLOJ C=3 cm

ZAVRŠNI RAD

IZRADIO

ANTE BILOŠ

AKADEMSKA GODINA 2016/2017

13.3.2017.

ARMATURA GREDE POZ.100

M 1:65

ARMATURA GREDE POZICIJA 200

MJ 1:65

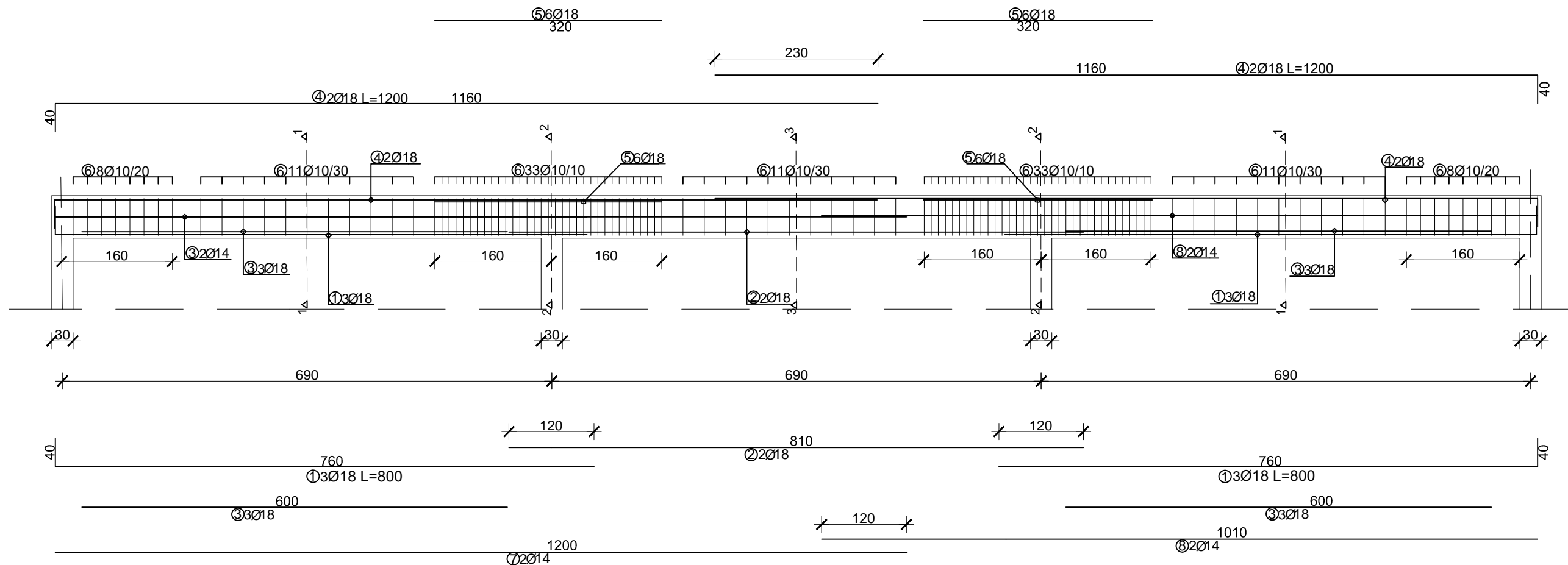

1-1
1:25

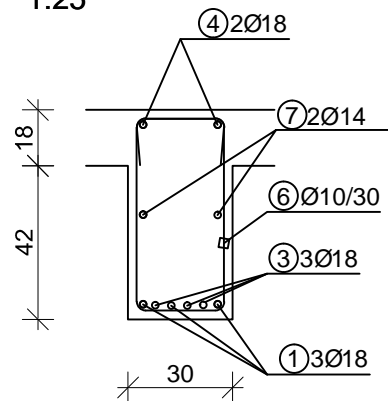

3-3
1:25

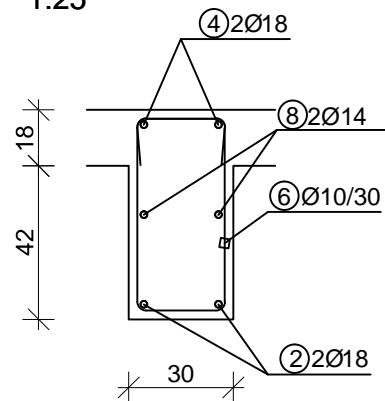

2-2
1:25

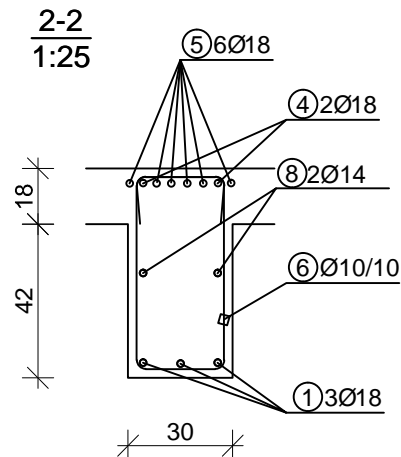

⑥Ø10/10/20/30 L=182 cm

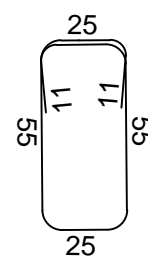

Šipke specifikacija

ozn.	oblik i dimenzije [cm]	φ	lg [m]	n [kom.]	lgn [m]	Jedinična-težina [kg/m ³]	Ukupna težina [kg]
1	40 760	18	8.00	6	48.00	1.998	95.90
2	810	18	8.10	2	16.20	1.998	32.37
3	600	18	6.00	6	36.00	1.998	71.93
4	40 1160	25	12.00	4	48.00	1.998	95.90
5	320	25	3.20	12	38.40	1.998	76.72
6	25 55 11 11 55	10	1.82	115	209.3	0.79	165.52
7	1200	14	12.00	2	24.00	1.208	29.00
8	1010	14	10.10	2	20.20	1.208	26.82

Ukupna težina: 594.16 [kg]

KLASA BETONA:
BETON C 40/50
ARMATURA B500B
ZAŠTITNI SLOJ C=3 cm

UCA SVEUČILIŠTE U SPLITU
FAKULTET GRAĐEVINARSTVA,
ARHITEKTURE I GEODEZIJE

UNIVERSITY OF SPLIT
FACULTY OF CIVIL ENGINEERING,
ARCHITECTURE AND GEODESY

ZAVRŠNI RAD

IZRADIO

ANTE BILOŠ

AKADEMSKA GODINA 2016/2017

13.3.2017.

ARMATURA GREDE POZ.200

M 1:65

UZDUŽNI PRESJEK KROZ STUBIŠTE

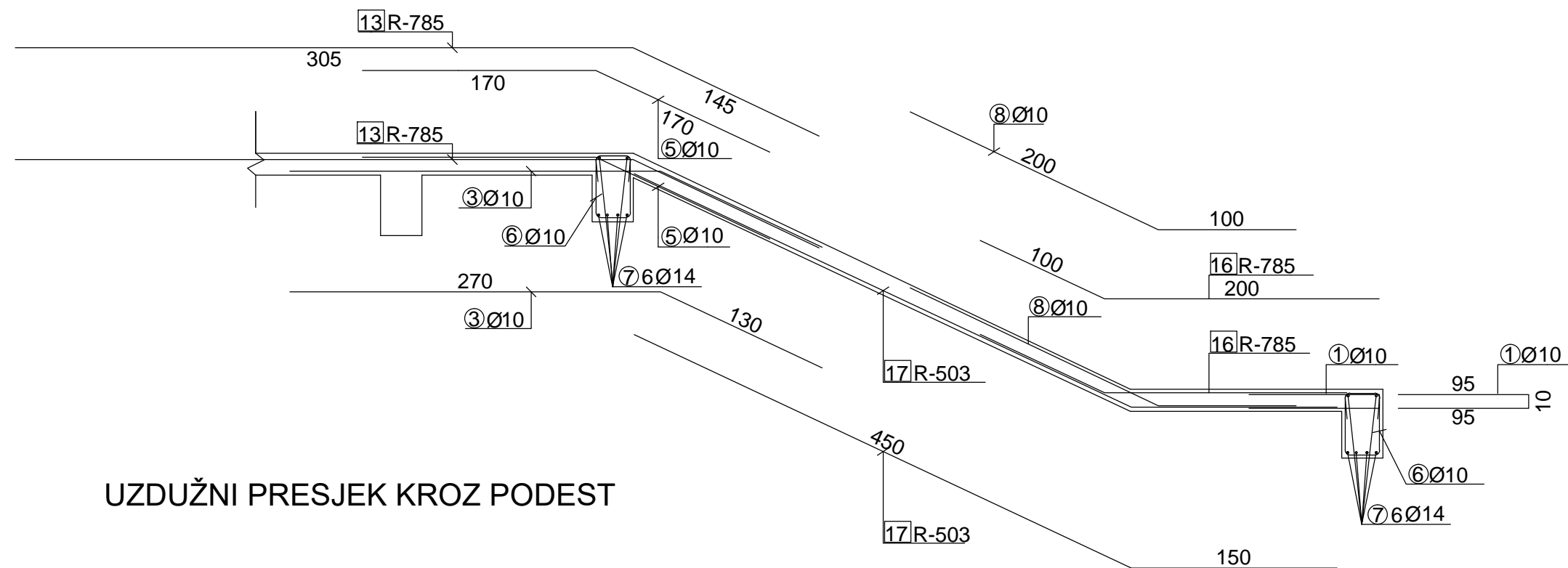

UZDUŽNI PRESJEK KROZ PODEST

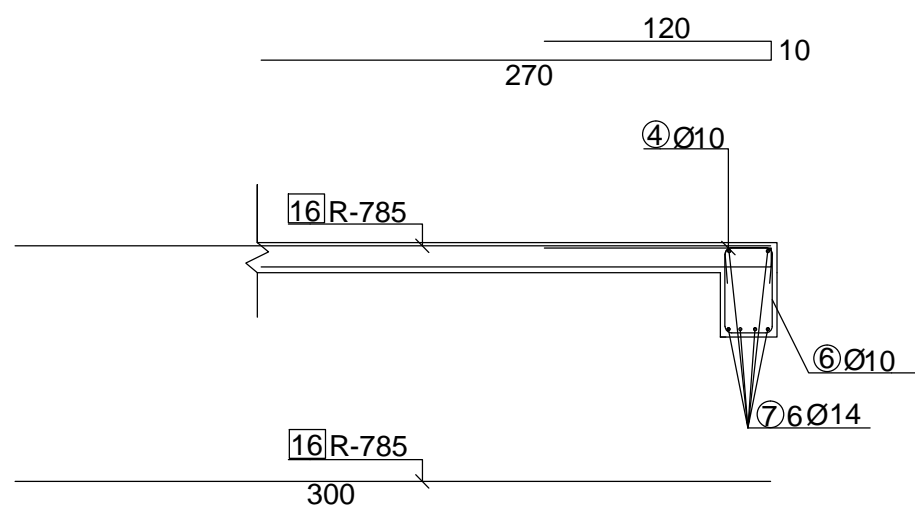

ARMATURA STUBIŠTA MJ 1:40

KLASA BETONA:
BETON C 40/50
ARMATURA B500B
ZAŠTITNI SLOJ C=3 cm

Šipke specifikacija							
ozn.	oblik i dimenzije [cm]	Ø	lg [m]	n [kom.]	lgn [m]	Jedinična-težina [kg/m']	Ukupna težina [kg]
POZICIJE 100 GORNJA ZONA							
1		10	2.00	10	20.00	0.79	15.80
3		10	4.00	15	60.00	0.79	47.40
4		10	4.00	16	64.00	0.79	50.56
5		10	3.40	14	47.60	0.79	37.60
6		14	6.00	12	72.00	1.208	87.00
8		10	3.00	14	42.00	0.79	33.18
Ukupna težina:							271.54

Mreže-specifikacija						
Pozicija	Oznaka mreže	B [cm]	L [cm]	n	Jedinična težina [kg/m2]	Ukupna težina [kg]
ARMATURA STUBIŠTA						
13	R-785	215	450	1	7.35	71.11
15	R-785	115	450	1	7.35	38.00
16	R-785	215	300	2	7.35	94.82
17	R-503	215	600	1	4.89	63.00
18	R-503	115	600	1	4.89	38.74
Ukupno						300.67

		SVEUČILIŠTE U SPLITU FAKULTET GRAĐEVINARSTVA, ARHITEKTURE I GEODEZIJE	UNIVERSITY OF SPLIT FACULTY OF CIVIL ENGINEERING, ARCHITECTURE AND GEODESY
ZAVRŠNI RAD			
IZRADIO		ANTE BILOŠ	
AKADEMSKA GODINA 2016/2017			13.3.2017.
ARMATURA STUBIŠTA			M 1:40

MJ 1:40

ARMATURA STUPA KROZ 2 ETAŽE

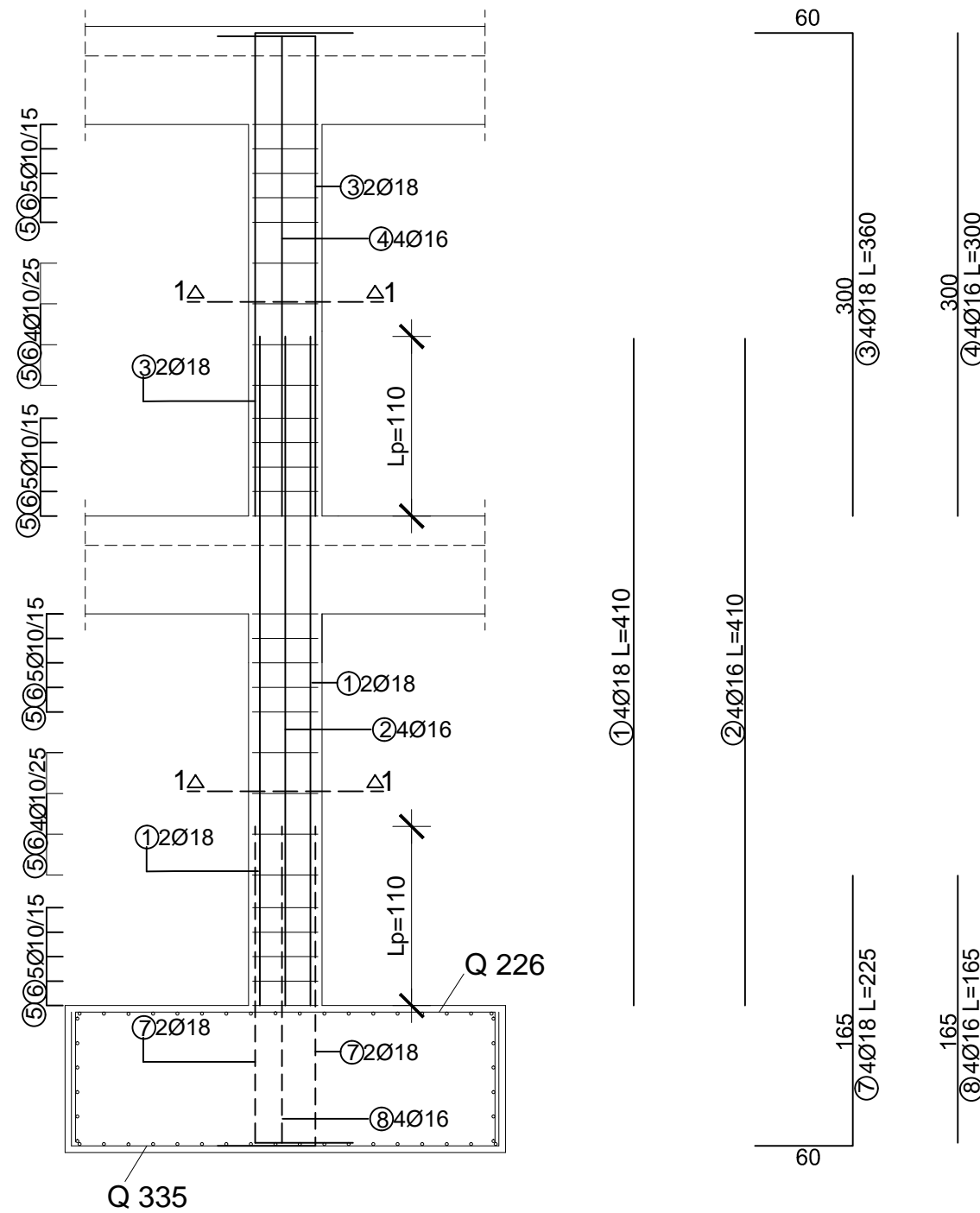

KLASA BETONA:
BETON C 40/50
ARMATURA B500B
ZAŠTITNI SLOJ C=3 cm

Šipke specifikacija							
ozn.	oblik i dimenzije [cm]	Ø	lg [m]	n [KOM.]	lgn [m]	Jedinična-težina [kg/m']	Ukupna težina [kg]
STUP 2.ETAŽA							
1	410	18	4.10	4	16.40	1.998	32.77
2	410	16	4.10	4	16.40	1.578	25.88
3	300	18	3.60	4	14.40	1.998	28.77
4	300	16	3.00	4	12.00	1.578	18.94
5		10	1.4	28	39.20	0.79	30.97
6		10	1.04	28	29.12	0.79	23.00
7	165	18	2.25	4	9.00	1.998	17.98
8	165	16	1.65	4	6.60	1.578	10.41
						Ukupna težina: 188.72 [kg]	

MJ 1:20

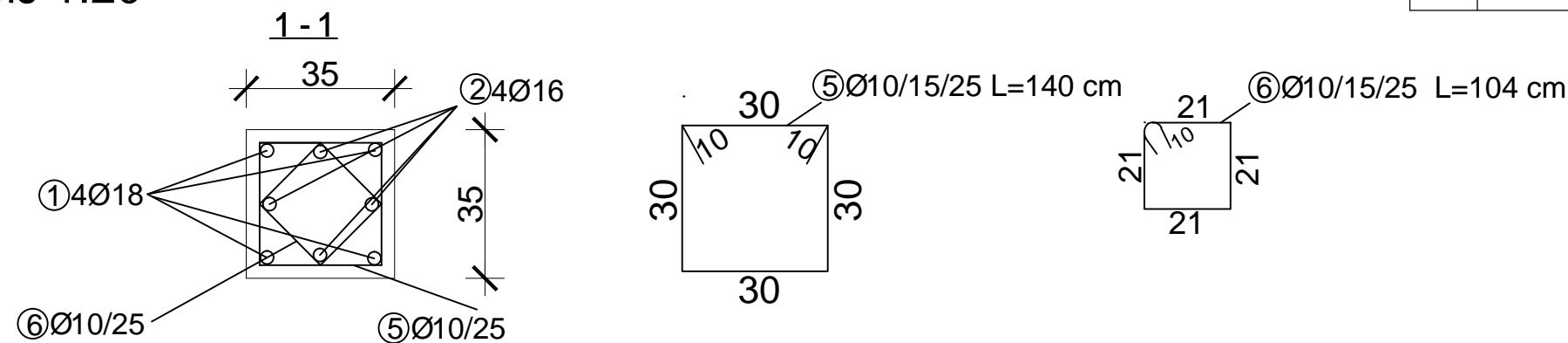

		SVEUČILIŠTE U SPLITU FAKULTET GRAĐEVINARSTVA, ARHITEKTURE I GEODEZIJE	UNIVERSITY OF SPLIT FACULTY OF CIVIL ENGINEERING, ARCHITECTURE AND GEODESY
ZAVRŠNI RAD			
IZRADIO	ANTE BILOŠ		
AKADEMSKA GODINA 2016/2017			13.3.2017.
ARMATURA STUPA KROZ 2 ETAŽE			M 1:40