

# Projekt konstrukcije Društvenog centra Mejaši

---

**Kojundžić, Ivan**

**Master's thesis / Diplomski rad**

**2017**

*Degree Grantor / Ustanova koja je dodijelila akademski / stručni stupanj:*

**University of Split, Faculty of Civil Engineering, Architecture and Geodesy / Sveučilište u Splitu, Fakultet građevinarstva, arhitekture i geodezije**

*Permanent link / Trajna poveznica:* <https://um.nsk.hr/um:nbn:hr:123:446276>

*Rights / Prava:* [In copyright](#)/[Zaštićeno autorskim pravom.](#)

*Download date / Datum preuzimanja:* **2025-01-02**



*Repository / Repozitorij:*

[FCEAG Repository - Repository of the Faculty of Civil Engineering, Architecture and Geodesy, University of Split](#)



UNIVERSITY OF SPLIT



DIGITALNI AKADEMSKI ARHIVI I REPOZITORIJI

**SVEUČILIŠTE U SPLITU  
FAKULTET GRAĐEVINARSTVA ARHITEKTURE I GEODEZIJE**

# **DIPLOMSKI RAD**

**Ivan Kojundžić**

**Split, 2017**

**SVEUČILIŠTE U SPLITU  
FAKULTET GRAĐEVINARSTVA ARHITEKTURE I GEODEZIJE**

**Ivan Kojundžić**

**Projekt konstrukcije Društvenog centra Mejaši**

**Diplomski rad**

**Split**, Error! Reference source not found.

## Projekt konstrukcije Društvenog centra Mejaši

### *Sažetak:*

Imajući kao predložak idejno rješenje Društvenog centra Mejaši izrađen je projekt konstrukcije. Napravljen je numerički model na kojem je provjerena stabilnost konstrukcije te je izvršeno dimenzioniranje elemenata konstrukcije u skladu s HRN EN 1993, HRN EN 1992 i HRN EN 1994. U finalnoj fazi su proračunati spojevi te izrađeni nacrti konstrukcije.

### *Ključne riječi:*

Društveni centar Mejaši, čelik, spojevi, numerički model

## Construction project of the Social Center Mejaši

### *Abstract:*

Considering the conceptual design of the Social Center Mejaši as a template, a construction project was created. A numerical model was constructed on which the stability of the construction was verified and the structural elements were dimensioned in accordance with HRN EN 1993, HRN EN 1992 and HRN EN 1994. In the final phase the compounds are calculated and constructed design drawings are made.

### *Keywords:*

Mejaši Social Center, steel, compounds, numerical model

**SVEUČILIŠTE U SPLITU  
FAKULTET GRAĐEVINARSTVA, ARHITEKTURE I GEODEZIJE**

Split, Matice hrvatske 15

STUDIJ: DIPLOMSKI SVEUČILIŠNI STUDIJ GRAĐEVINARSTVA  
KANDIDAT: Ivan Kojundžić  
BROJ INDEKSA: 587  
KATEDRA: **Katedra za metalne i drvene konstrukcije**  
PREDMET: Metalne konstrukcije

**ZADATAK ZA DIPLOMSKI RAD**

Tema: Projekt konstrukcije Društvenog centra Mejaši

Opis zadatka: Zadatak diplomskog rada je projektiranje čelične konstrukcije Društvenog centra Mejaši smještenog u Splitu, s geometrijom 48,0 m x 60,0 m. Visina konstrukcije je 15,15 m.  
Potrebno je izraditi model konstrukcije te izvršiti proračun i dimenzioniranje elemenata konstrukcije u skladu s HRN EN 1993, HRN EN 1992 i HRN EN 1994.  
Također je potrebno proračunati spojeve konstrukcije te izraditi pripadajuće nacрте.

U Splitu, 07.03.2017.

Voditelj diplomskog rada:

Prof. dr. sc. Ivica Boko

Predsjednik Povjerenstva  
za završne i diplomske ispite:

Dr. sc. Veljko Srzić

## SADRŽAJ

1.	TEHNIČKI OPIS .....	7
2.	NUMERIČKI MODEL KONSTRUKCIJE .....	13
3.	ANALIZA OPTEREĆENJA .....	16
3.1	Stalno opterećenje.....	16
3.2	Dodatno stalno opterećenje .....	16
3.3	Promjenjivo opterećenje – korisno opterećenje na međukatnim konstrukcijama.....	17
3.4	Promjenjivo opterećenje –snijeg .....	18
3.5	Promjenjivo djelovanje – vjetar.....	21
3.6	Promjenjivo djelovanje –trenjem po krovu .....	33
3.7	Promjenjivo djelovanje –temperatura.....	35
3.8	Kombinacije djelovanja .....	37
4.	DIMENZIONIRANJE ELEMENATA KONSTRUKCIJE .....	40
4.1	Pomaci konstrukcije .....	40
4.2	Dimenzioniranje stupa .....	43
4.3	Dimenzioniranje pojasnice krovnog nosača .....	50
4.4	Dimenzioniranje vertikalne ispune krovnog nosača.....	58
4.5	Dimenzioniranje kose grede krovne konstrukcije.....	66
4.6	Dimenzioniranje dijagonale krovnog nosača.....	75
4.7	Dimenzioniranje krovne podrožnice .....	82
4.8	Dimenzioniranje krovne horizontalne grede .....	90
4.9	Dimenzioniranje bočne podrožnice .....	99
4.10	Dimenzioniranje sprega .....	107
4.11	Dimenzioniranje grednog nosača međukatne konstrukcije .....	109
4.12	Dimenzioniranje spregnute međukatne konstrukcije .....	116
5.	DINAMIČKA ANALIZA.....	131
6.	ANALIZA STABILNOSTI KONSTRUKCIJE .....	136
7.	SPOJEVI.....	140
7.1	Spoj stupa s temeljom.....	140
7.2	Spoj međukatne grede sa stupom .....	145
7.3	Dimenzioniranje nastavka međukatne grede .....	149
7.4	Dimenzioniranje spoja kose krovne grede sa pojasom krovne rešetke .....	152
7.5	Spoj stupa i krovne rešetke .....	155
7.6	Spoj kose krovne grede sa krovnom podrožnicom.....	159

7.7	Spoj stupa i bočne podrožnice .....	161
7.8	Spoj sprega sa stupom .....	164
7.9	Nastavak pojasa krovne rešetke .....	166
7.10	Spoj horizontalne krovne grede i krovne rešetke .....	168
8.	DIMENZIONIRANJE TEMELJA SAMCA .....	169
9.	NACRTI .....	170
10.	LITERATURA .....	171

 pdfelement

## 1. TEHNIČKI OPIS

### Opis konstrukcije

Predmet ovog projekta je čelična konstrukcija Društvenog centra Mejaši smještena na području Splita. Parcela predviđena za izgradnju objekta nalazi se u gradskom predijelu Mejaši na kaskadom terenu, a postavljena je u smjeru zapad – istok. Pristupni putevi za objekt smješteni su na južnoj strani parcele.

Dio slobodne neizgrađene površine služiti će za pješačku komunikaciju, a manji dio kao dodatni parkirni prostor.

Objekt je planiran kao višetažna konstrukcija sa sportskim sadržajem koji uključuju dvije dvorane. Parkirni prostor je osiguran već postojećim kapacitetima.

Konstrukcija je organizirana kao jedan konstruktivno-funkcionalan sklop. Glavnu konstrukciju objekta čine stupovi koji tvore pravilan raster na rasponu od 10 m u y smjeru, 8 m u x smjeru. Visine stupova su različite jer prate kaskadnu temeljnu ploču. Iznad stupova se nalazi krovna rešetka visine 3,5 m koja sa krovnom kosom gredom tvori višestrešni „shed“ krov. Konstruktivni sistem je sastavljen od čeličnih vrućevaljanih profila. Međukatne konstrukcije tvori spregnuta ploča raspona 10,0x8,0 m koja je postavljena na pravokutne međukatne grede.

Ukupna širina objekta je 48,0 metara, dok duljina iznosi 60,0 m. Ukupna površina krovne plohe je cca 2880 m<sup>2</sup>. Visina objekta je 15,15 m.

Krovna rešetka se sastoji od 12 polja raspona 5,0 m. Spoj stupa i rešetkaste konstrukcije proračunat je kao upeti. Veza stupa i rešetke ostvariti će se čeonim pločama i vijcima, gdje se vrh stupa direktno veže na donji pojas rešetke. Stupovi su kvadratnog poprečnog presjeka te su upeto vezani za temelje.

Sekundarnu konstrukciju tvore krovne i bočne podrožnice te spregovi koji su postavljeni u prvo i predzadnje polje konstrukcije. Sekundarna konstrukcija je zglobno vezena za glavnu konstrukciju objekta

Temelji su armirano betonske konstrukcije, izvedeni kao temelji samci, kvadratnog tlocrtnog oblika, dimenzije stranice 2,0 m. Visina temelja je 0,5 m. Iznad temelja je postavljena temeljna ploča debljine 20,0 cm koja nije predmet ovog projekta.

Izveden je višestrešni kosi krov, a problem otjecanja vode će se riješiti pocinčanim žljebovima smještenim u uvala krova.



Opterećenje koje djeluje na krov prenosi se preko krovne rešetke i kose krovne grede na stupove konstrukcije. Krovni paneli su direktno vezani za krovnu rešetku i kosu krovnu gredu te krovnu podrožnicu vijcima.

Krovne rešetke su ravninski nosači koji će se prilikom montaže međusobno vezivati dodatnim montažnim elementima i kao takvi će tvoriti jednu cjelinu.

### **O proračunu konstrukcije**

Proračun konstrukcije izveden je uz korištenje programskog paketa Scia Engineer 2016. Proračun reznih sila, te dimenzioniranje konstruktivnih elemenata, provedeno je korištenjem programa Scia Engineer 2015, dok je za grafički dio projekta korišten program AutoCAD 2017.

Proračun reznih sila izvršen je po linearnoj teoriji elastičnosti prvog reda. Proračunom su obuhvaćena sva djelovanja na konstrukciju, a to su vlastita težina, dodatno stalno opterećenje, opterećenje vjetrom, opterećenje snijegom kao i temperaturna djelovanja.

S obzirom na lokaciju objekta napravljena je analiza opterećenja koja obuhvaća djelovanje snijega i vjetra. Objekat se nalazi na području Splita, što spada u III zonu opterećenja snijegom, ili područje C, što daje karakterističnu vrijednost opterećenja snijegom na tlu. U obzir je uzeta i nadmorska visina na kojoj se nalazi objekat. Za opterećenje vjetrom uzeta je zona III, kategorija zemljišta IV, te regija P9 koja obuhvaća južnojadransko priobalje, te je u obzir uzeta visina objekta i njegova zaštićenost.

Pošto je vjetar dominantno opterećenje za ovakav tip objekta, posvećena mu je velika pažnja te je promatrano posebno tlačno i podtlačno djelovanje vjetra, kao i trenje u krovnoj plohi.

Djelovanje vjetra je promatrano kao i jedna koncentrirana ekscentrična sila na krovnu konstrukciju za provjeru mogućih nepovoljnih utjecaja uslijed ekscentriciteta.

Za stupove je također izvršena analiza opterećenja vjetrom, a opterećenje je zadano kao jednoliko kontinuirano djelovanje po dužini stupa.

Za svaki element konstrukcije određena je mjerodavna kombinacija opterećenja za provjeru krajnjeg graničnog stanja i graničnog stanja uporabljivosti.

Za svaku granično stanje napravljene su posebne kombinacije uz poštivanje parcijalnih faktora sigurnosti prema EN 1991.

Rezultati prikazani u grafičkom dijelu ovog projekta uključuju rezne sile i pomake određenih dijelova konstrukcije. Rezne sile su dane u jedinicama kN za poprečne i uzdužne sile, kNm za momente, te u mm za pomake konstrukcije.

Svi elementi konstrukcije su modelirani u programu Scia Engineer 2016. Konstrukcija je prikazana prostornim modelom s opterećenjem koji djeluje okomito i u ravnini krovne plohe. Pojasni elementi rešetkastih nosača modelirani su kao gredni elementi, dok je ispuna krovne rešetke i stupova definirana kao štapni element koji prenosi samo uzdužnu silu.

Ovakvim definiranjem modela možemo smatrati da su ostvaruje zglobna veza na spoju ispune i pojasa rešetkastih nosača. Spoj stupova s temeljima su tretirani kao upeti. Sekundarna konstrukcija je modelirana kao prosta greda koja je zglobno vezana sa glavnom konstrukcijom.

Uzete su sve mjerodavne kombinacije opterećenja u obzir, te je svaki element dimezioniran sukladno njegovim reznim silama.

Temelji su dimezionirani prema graničnom stanju uporabljivosti.

### **Materijal za izradu konstrukcije**

Materijal za izradu glavne nosive krovne konstrukcije, kao i stupova je čelik S 275. Konstruktivni elementi će međusobno biti vezani vijčanim spojevima. Vijci korišteni za izvedbu ove konstrukcije su M 20 i M 30, svi kvalitete 10.9 . Spojevi i nastavci elemenata konstrukcije uključuju dodatne ploče i ukrute, također iste kvalitete čelika.

Za oblogu objekta koristim panele od pleksiglasa, koji imaju malu vlastitu težinu i omogućuju prolazak dnevnog svjetla.

Za spregnutu konstrukciju korišten je beton klase C 25/30.

Temelji su armirano betonski, klasa betona C 25/30, armatura je B 500 B.

### **Opis montaže konstrukcije**

Izvedba konstrukcije je montažna. Svi elementi konstrukcije predgotovljeni stižu na gradilište te se međusobno vežu vijcima. Sama krovna konstrukcija koju tvori krovna rešetka je izvedena od 5 ravinskih segmenata koji se sa kosom krovnom gredom i podrožnicama čine funkcionalnu krovnu konstrukciju.

Nulta faza montaže, nakon izvedenih svih prethodno potrebnih radova, je montaža stupova. Kada se stup postavi na ankere koji su postavljeni u temelje, stup se pridržaje dizalicom dok se ne postigne vertikalnost pomoću dvostrukih vijaka. Nakon provjere vertikalnosti, vrši se ispunjenje prostora ispod spojne ploče i temelja ekspandirajućim mortom.

Nakon toga se na stupove vežu međukatne grede koje sa spregnutim pločama tvore utazu konstrukcije. Sljedeći korak je postavljanje krovne rešetke koja je na spoju sa stupom pridržana horizontalnom krovnom gredom.

Nakon toga se postavlja kosa krovna greda te pripadajuća sekundarna konstrukcija. iduceg okvira te povezivanje njih sekundarnim segmentima.

Ovakav način montaže odabran je iz razloga što na raspolaganju imamo dizalicu male nosivosti.

## Primjenjeni propisi

Proračun i dimenzioniranje svih elemenata čelične konstrukcije provedeni su u skladu sa EUROCODE 3, a analiza djelovanja na konstrukciju napravljena je u skladu sa EUROCODE 1. Proračun i dimenzioniranje betonskih elemenata konstrukcije te spregnute konstrukcije provedeno je u skladu sa EUROCODE 2 i EUROCODE 4. Posebno je provedn proračun zavarenih spojeva prema EN 1993, dio 1-8.

## Antikorozivna zaštita

Kod čelika pod korozijom se podrazumijeva oksidacija željeza pri djelovanju vlage i raznih nečistoća. Agensi koji ubrzavaju hrđanje su zagađena atmosfera, industrijsko područje zagađeno sumporom, sol itd.

Zaštita čeličnih konstrukcija od hrđanja vrši se:

- premazima
- zaštita cinkom
- metalizacijom
- uporabom specijalnih čelika
- katodnom zaštitom

Zaštita premazima obavlja se u svrhu spriječavanja da kisik i vlaga dođu u dodir s čelikom.

Premazivanje se obično vrši bojanjem u dva sloja: osnovni premaz i zaštitni premaz. Osnovni premaz neposredno štiti čelik, a potrebno je da bude izrađen od tvari koje nisu štetne po ljudsko zdravlje. Zaštitni sloj služi za zaštitu osnovnog premaza.

Prerano propadanje konstrukcije najčešće nastaje usljed loših detalja u konstrukciji (nepristupačna mjesta za bojenje, mjesta gdje se zadržava voda, oštri bridovi gdje se nemože nanijeti zahtjevana debljina premaza i sl.) koje treba nastojati izbjegavati.

Sistem zaštite bojenjem sastoji se iz:

- Priprema površine – trajnost premaza ovisi o prionjivosti boje za metalnu površinu, što ovisi o čistoći površine prije bojanja. Čišćenje se vrši četkama, pijeskarenjem, plamenikom ili kemijskim sredstvima.
- Nanošenje boje – bojenje se vrši četkom, valjkom ili prskanjem. Treba paziti na ograničenja za pojedine boje. Broj slojeva premaza obično se sastoji od dva a specifično od četiri ili više slojeva. Novi premaz može se vršiti tek kad je prethodni potpuno suh. Debljini premaza

potrebno je posvetiti posebnu pažnju. Općenito, deblji premaz povećava trajnost zaštite. Ukupna debljina suhih premaza treba se kretati između 0,1-0,4 mm.

Dobro izvedeni premazi traju:

- do 30 godina u zatvorenoj prostoriji
- do 20 godina kod konstrukcija zaštićenih od kiše
- do 10 godina u prirodi
- 2-3 godine u zagađenom okolišu

Zaštita pocinčavanjem podrazumijeva vrste zaštite koje se ostvaruju nanošenjem prevlake cinka i po toplom postupku. Mase i debljine prevlaka cinka za pojedine elemente određene su prema Pravilniku o tehničkim mjerama i uvjetima za zaštitu čeličnih konstrukcija od korozije i ne mogu biti manje od 500g/m<sup>2</sup> elementa debljine 5 mm. Sve čelične konstrukcije prethodno treba odmastiti, očistiti razblaženom otopinom klorovodične kiseline te isprati hladnom vodom. Neposredno prije pocinčavanja čelična konstrukcija se stavlja u taljevinu ili otopinu za flusiranje.

Toplo pocinčavanje se izvodi stavljanjem tekućine u rastopljeni cink. Cink mora biti kvaliteta Zn 97,5 do Zn 99,5 prema HRN EN ISO 14713:2001. Prevlaka cinka dobivena toplim postupkom mora biti homogena i mora prekrivati osnovicu. Prevlaka cinka mora čvrsto prijanjati za čeličnu površinu i ne smije se ljuštiti niti pucati pri uporabi. Prije montaže potrebno je izvršiti kontrolu prevlake cinka prema HRN C.A1. 558, odnosno mase prevlake cinka prema HRN A6.021.

### **Protupožarna zaštita**

Pri izvedbi osigurat će se provedba svih propisa o zaštiti od požara. Pristup i intervencija vatrogasnog vozila omogućit će se sa južne strane parcele. Zahtijevana vatrootpornost elemenata čelične konstrukcije F30. Osiguranje vatrootpornosti osiguravamo specijalnim ekspandirajućim premazima.

## 2. NUMERIČKI MODEL KONSTUKCIJE

Numerički 3D render modela konstrukcije je izrađen u Scia Engineer 2016.

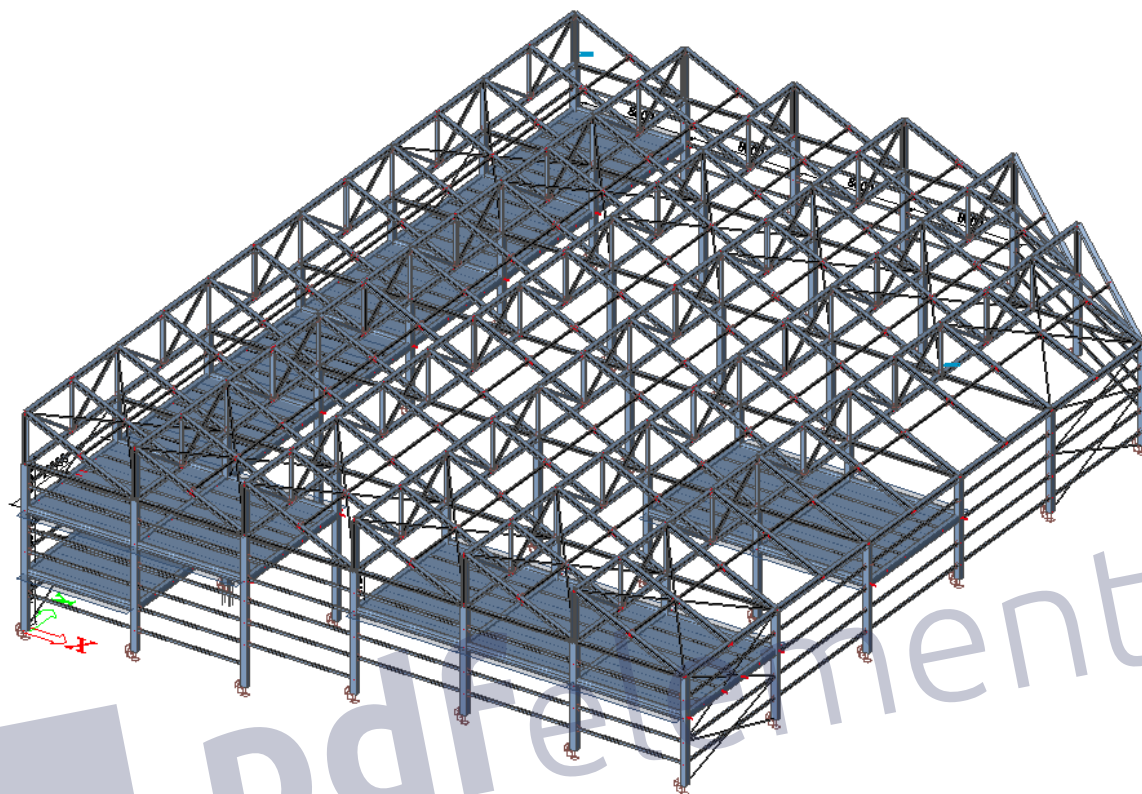

Slika 1: Izometrijski prikaz 3D modela

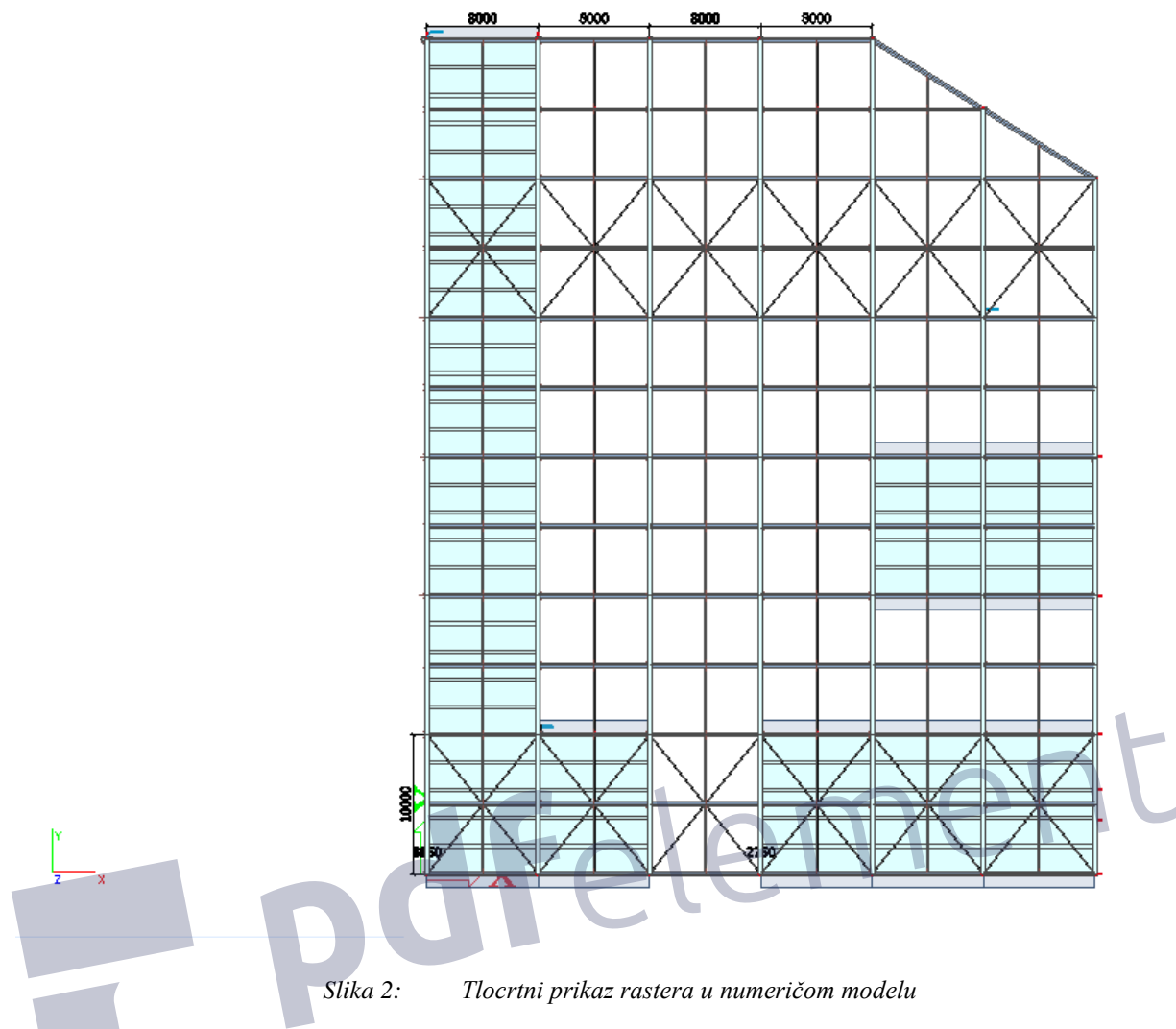

Slika 2: Tlocrtni prikaz rastera u numeričom modelu

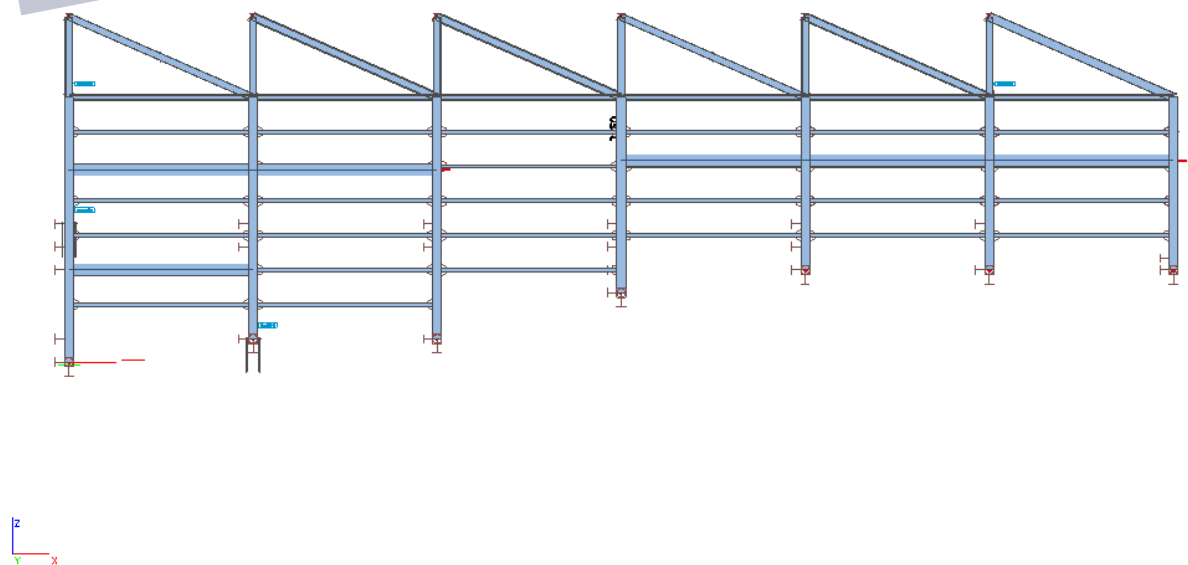

Slika 3: Prikaz zapadnog pročelja

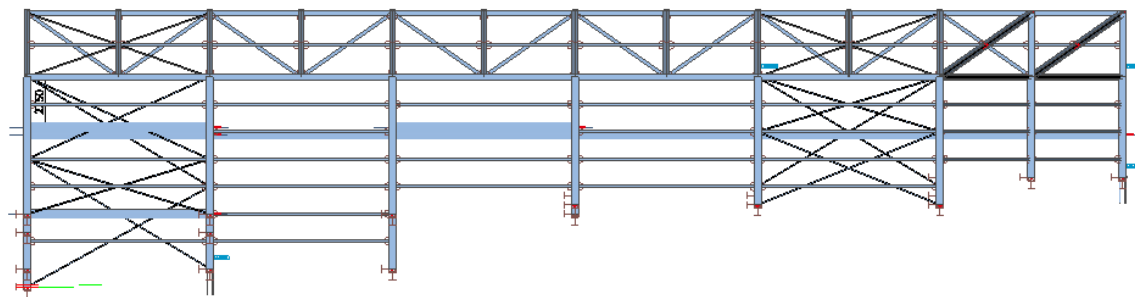

Slika 4: Prikaz južnog pročelja

pdfelement



### 3. ANALIZA OPTEREĆENJA

#### 3.1 Stalno opterećenje

Vlastita težina uračunata u softveru.

#### 3.2 Dodatno stalno opterećenje

Opterećenje na krovnu konstrukciju:

- Sendvič paneli:  $g=0,20 \text{ kN/m}^2$
- Instalacije:  $g=0,10 \text{ kN/m}^2$

Opterećenje na međukatnu konstrukciju:

- Namještaj:  $g=0,10 \text{ kN/m}^2$
- Slojevi poda:  $g=0,10 \text{ kN/m}^2$

DODATNO STALNO OPTEREĆENJE NA KROVU $\Delta g$				
NOSAČ	UTJECAJNA POVRŠINA	$\Delta g$ (kN/m <sup>2</sup> )	L(m)	$\Delta g$ (kN/m)
RUBNI NOSAČ	P1	0.3	2.5	0.75
SREDNJI NOSAČ	P2	0.3	5	1.50

DODATNO STALNO OPTEREĆENJE NA BOČNE STUPOVE $\Delta g$				
NOSAČ	UTJECAJNA POVRŠINA	$\Delta g$ (kN/m <sup>2</sup> )	L(m)	$\Delta g$ (kN/m)
RUBNI NOSAČ	A1	0.2	5	1.00
SREDNJI NOSAČ	A2	0.2	10	2.00

DODATNO STALNO OPTEREĆENJE NA STUPOVE ZABATA $\Delta g$				
NOSAČ	UTJECAJNA POVRŠINA	$\Delta g$ (kN/m <sup>2</sup> )	L(m)	$\Delta g$ (kN/m)
RUBNI STUP	P1	0.2	4	0.80
SREDNJI STUP	P2	0.2	8	1.60

Tablica 1. Vrijednosti dodatnog opterećena na konstrukciju

### 3.3 Promjenjivo opterećenje – korisno opterećenje na međukatnim konstrukcijama

Kategorija C -Površine na kojima je moguće okupljanje ljudi

$g=3,0 \text{ kN/m}^2$

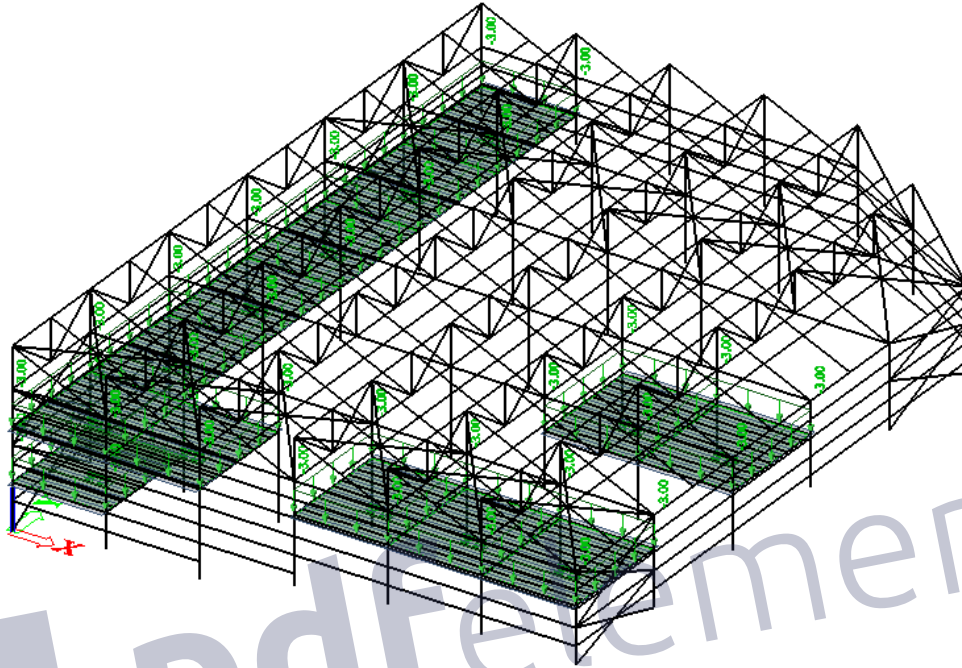

Slika 5: Prikaz korisnog opterećenja na međukatnu konstrukciju

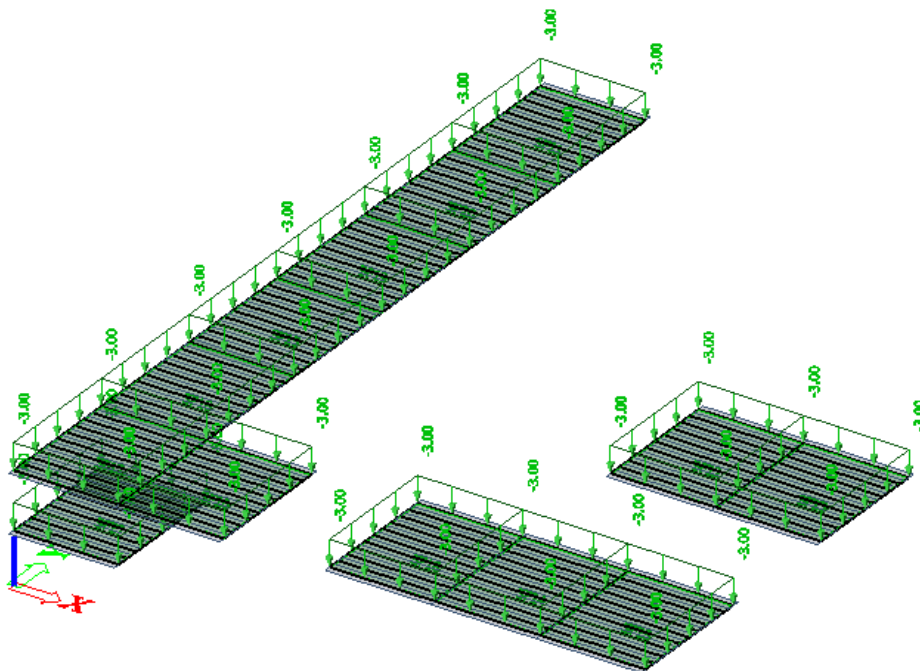

Slika 6: Izdvojeni prikaz korisnog opterećenja na međukatnu konstrukciju

### 3.4 Promjenjivo opterećenje –snijeg

Opterećenje snijegom na krovu

$$s = \mu_1 \cdot C_e \cdot C_t \cdot s_k$$

-  $\mu_1$ ,  $\mu_2$  - koef. oblika za opterećenje snijegom

krov nagiba  $0^\circ \leq \alpha \leq 30^\circ \Rightarrow \mu_1 = 0,8$

$$\Rightarrow \mu_2 = 0,8 + 0,8\alpha / 30 = 0,8 + 0,8 \cdot 24 / 30 = 1,44$$

-  $s_k$  - karakteristična vrijednost opterećenja na tlu u  $[kN/m^2]$

zona Split, područje C (zona II), nadmorska visina do 100 m  $\Rightarrow s_k = 0.50 kN/m^2$

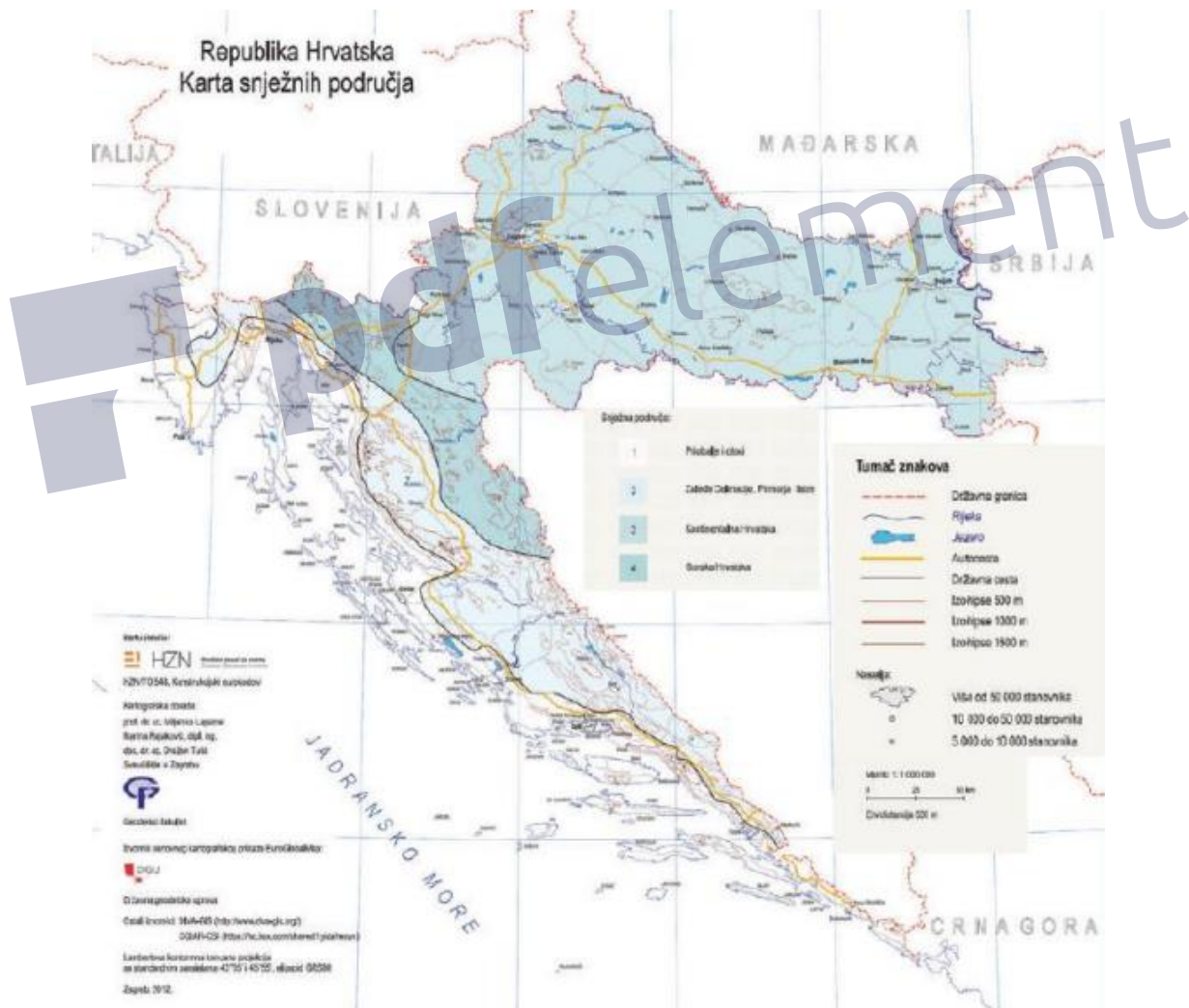

Slika 7: Karta opterećenja snijegom

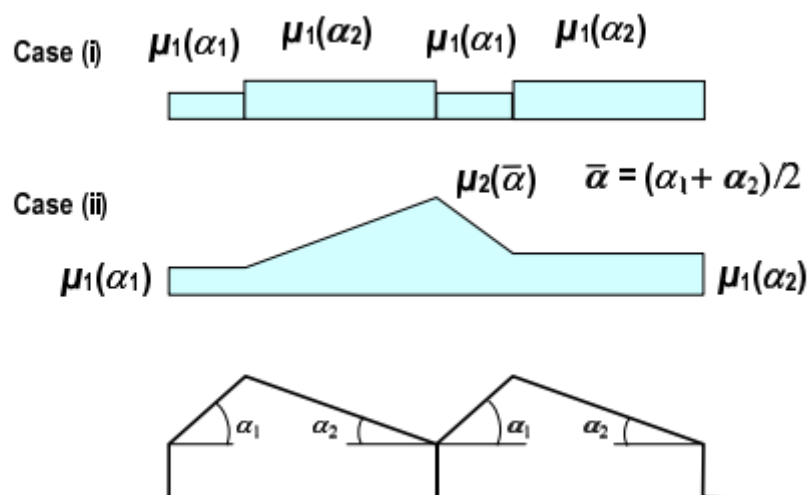

Slika 8: Prikaz rasporeda opterećanja za višestrešne krovove sa uvalama

Angle of pitch of roof $\alpha$	$0^\circ \leq \alpha \leq 30^\circ$	$30^\circ < \alpha < 60^\circ$	$\alpha \geq 60^\circ$
$\mu_1$	0,8	$0,8(60 - \alpha)/30$	0,0
$\mu_2$	$0,8 + 0,8 \alpha/30$	1,6	--

Slika 9: Vrijednosti koeficijenta oblika

-  $C_e$  - koef. izloženosti  $\Rightarrow C_e = 1,0$

-  $C_t$  - toplinski koef.  $\Rightarrow C_t = 1,0$

$$\Rightarrow s_1 = 0,8 \cdot 1,0 \cdot 1,0 \cdot 0,5 = 0,4 \text{ [kN / m}^2 \text{]}$$

$$\Rightarrow s_2 = 1,44 \cdot 1,0 \cdot 1,0 \cdot 0,5 = 0,72 \text{ [kN / m}^2 \text{]}$$

OPTEREĆENJE SNIJEGOM S1				
NOSAČ	UTJECAJNA POVRŠINA	S (kN/m <sup>2</sup> )	L(m)	S (kN/m)
RUBNI NOSAČ	P1	0.5	2.5	1.25
SREDNJI NOSAČ	P2	0.5	5	2.5

OPTEREĆENJE SNIJEGOM S2				
NOSAČ	UTJECAJNA POVRŠINA	S (kN/m <sup>2</sup> )	L(m)	S (kN/m)
RUBNI NOSAČ	P1	0.72	2.5	1.8
SREDNJI NOSAČ	P2	0.72	5	3.6

Tablica 2. Vrijednost opterećenja snijegom na krovnu konstrukciju

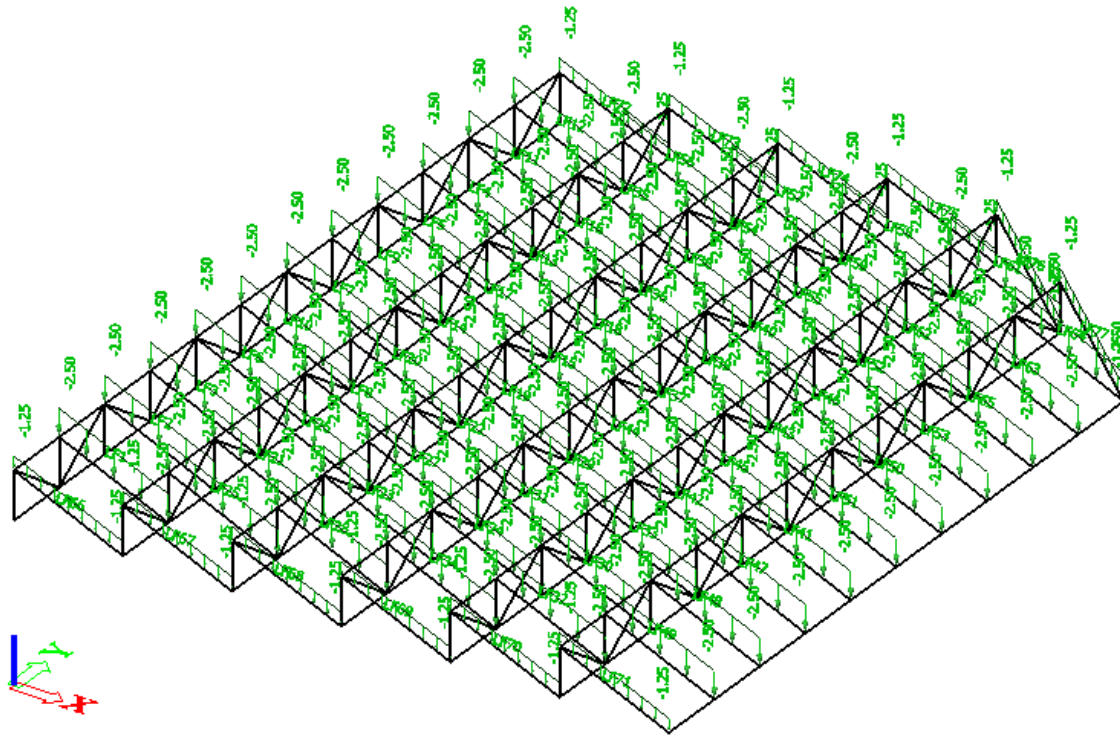

Slika 10: Prikaz opterećenja za snijeg 1

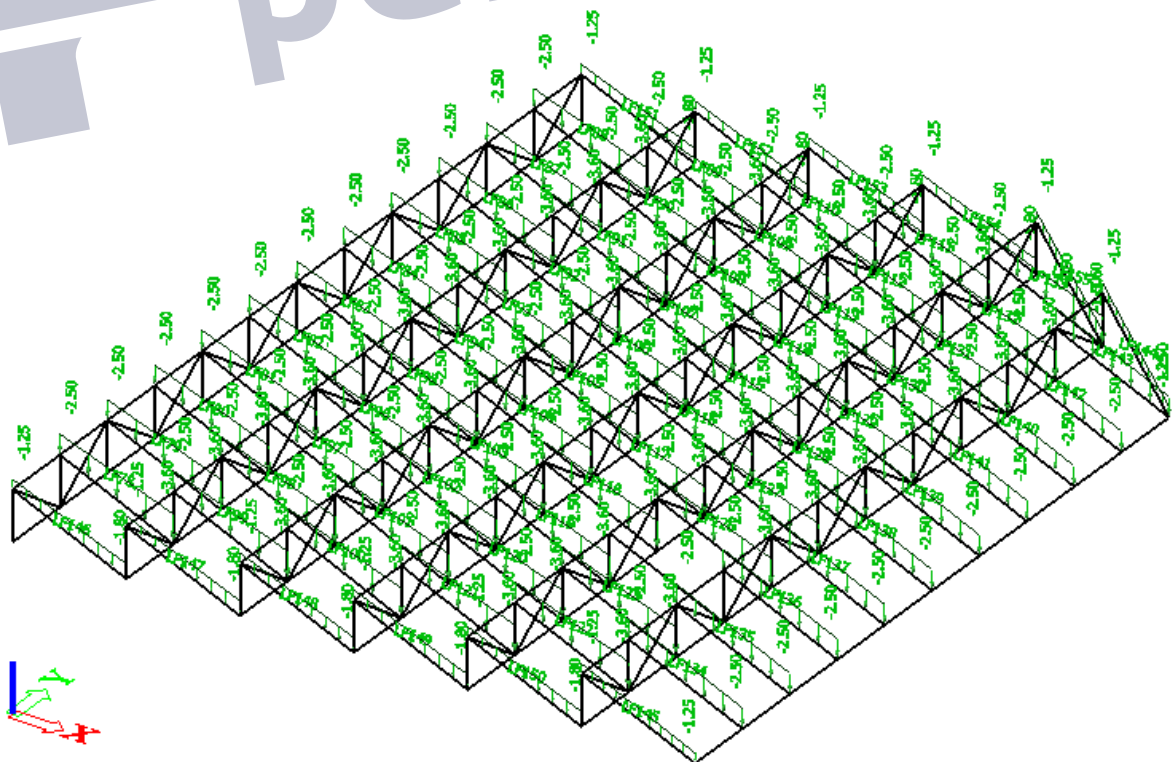

Slika 11: Prikaz opterećenja za snijeg 2

### 3.5 Promijenjivo djelovanje – vjetar

- pritisak vjetra na vanjske površine:  $w_e = q_p * C_e(z_e) * C_{pe}$  [kN/m<sup>2</sup>]

- pritisak vjetra na unutarnje površine:  $w_i = q_p * C_e(z_i) * C_{pi}$  [kN/m<sup>2</sup>]

gdje je:

$q_b$  – osnovni pritisak vjetra pri srednjoj brzini vjetra

$C_e(z_e); C_e(z_i)$  – koeficijenti izloženosti koji uzimaju u obzir neravnine terena

$z_e; z_i$  – poredbene visine za lokalni ili unutarnji tlak

$C_{pe}; C_{pi}$  – vanjski i unutarnji koeficijent pritiska

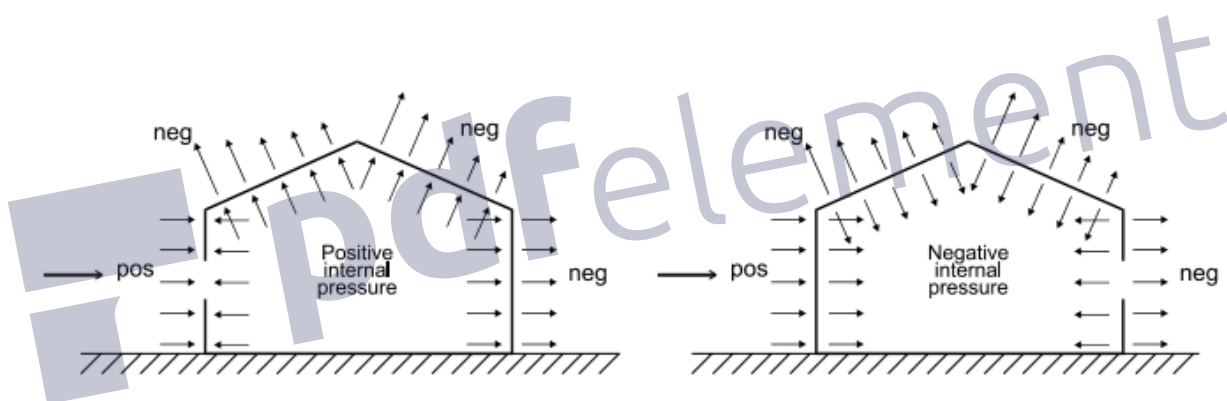

Slika 12: Prikaz pritiska vjetra na konstrukciju

$$q_b = \frac{1}{2} \cdot \rho \cdot v_b^2 \text{ [kN/m}^2\text{]}$$

gdje je:

$v_b$  – osnovna brzina vjetra

$\rho$  – gustoća zraka ( $\rho=1,25 \text{ kg/m}^3$ )

Osnovna brzina vjetra  $v_b$ , dana je izrazom:

$$v_b = C_{dir} * C_{season} * v_{b0}$$

gdje je:

$v_b$  – osnovna brzina vjetra

$c_{dir}$  – koeficijent smjera vjetra (obično uzima vrijednost 1,0)

$c_{season}$  – koeficijent ovisan o godišnjem dobu (obično uzima vrijednost 1,0)

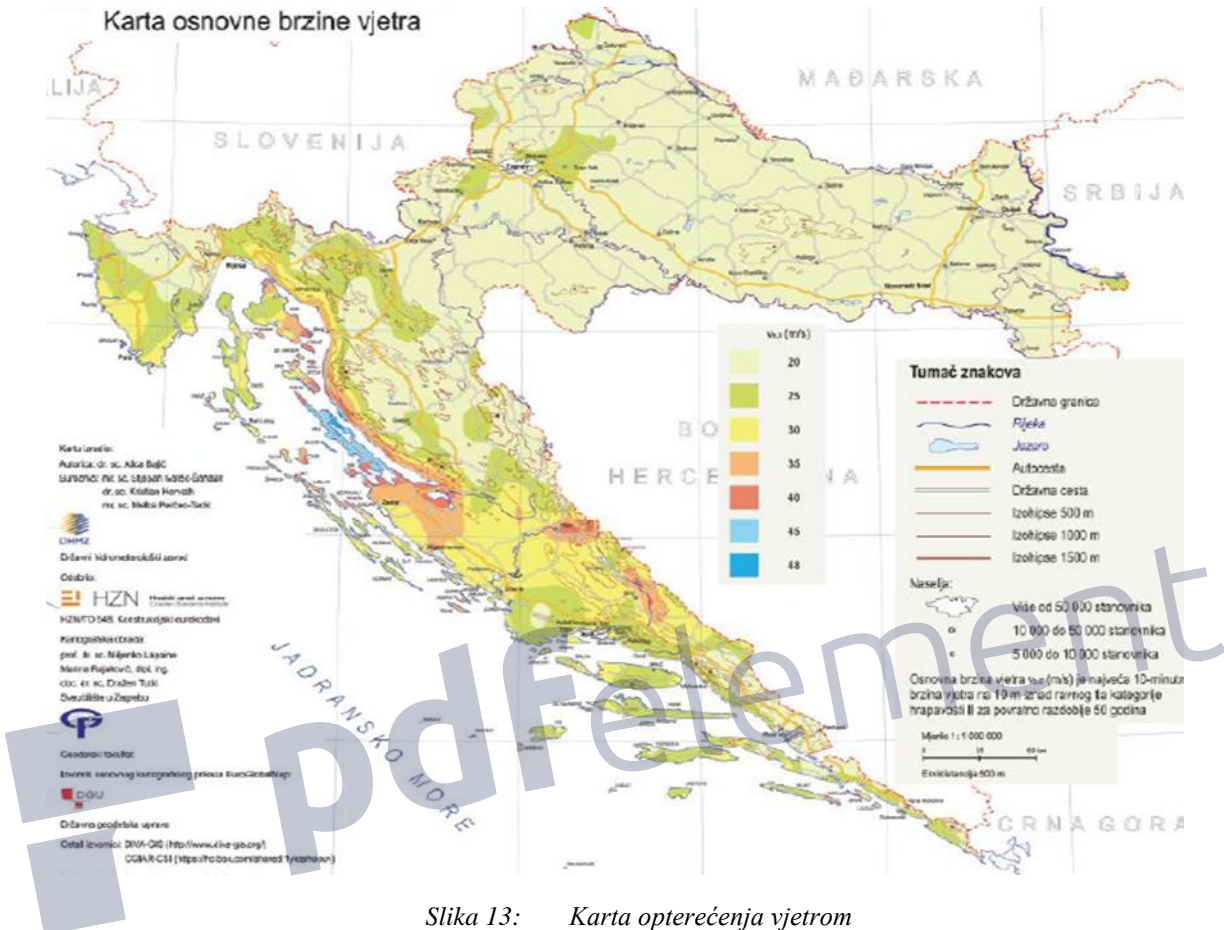

Slika 13: Karta opterećenja vjetrom

Osnovni pritisak vjetra:

$$v_b = 30,0 \left( \frac{m}{s} \right) \rightarrow \text{očitano za Split}$$

$$C_{dir} = C_{season} = 1,0$$

$$v_b = v_{b,0} \cdot C_{dir} \cdot C_{season} = 30 \cdot 1,0 \cdot 1,0 = 30,0 \left( \frac{m}{s} \right)$$

$$\rho = 1,25 \frac{kg}{m^3}$$

$$q_b = \frac{\rho}{2} \cdot v_b^2 = \frac{1,25}{2} \cdot 30,0^2 = 562,5 \left( \frac{N}{m^2} \right) = 0,56 \left( \frac{kN}{m^2} \right)$$

Faktor terena  $k_r$  -za kategoriju terena IV :

$$k_r = 0,19 \cdot \left(\frac{z_0}{z_{0,II}}\right)^{0,07} = 0,19 \cdot \left(\frac{1,0}{0,05}\right)^{0,07} = 0,234$$

$$C_{r(z)} = k_r \cdot \ln\left(\frac{z}{z_0}\right) = 0,234 \cdot \ln\left(\frac{15,0}{1,0}\right) = 0,633$$

$$C_{0(z)} = 1,0$$

Srednja brzina vjetra iznad terena:

$$v_{m(7,15)} = v_b \cdot C_{r(z)} \cdot C_{0(z)} = 30 \cdot 0,633 \cdot 1,0 = 18,99 \left(\frac{m}{s}\right)$$

Intezitet turbulencije:

$$I_{v(z)} = \frac{k_I}{C_{0(z)} \cdot \ln\left(\frac{z}{z_0}\right)} = \frac{1}{1 \cdot \ln\left(\frac{15}{1,0}\right)} = 0,369$$

Pritisak brzine vjetra pri udaru:

$$q_{p(z)} = [1 + 7 \cdot I_{v(z)}] \cdot \rho / 2 \cdot v_m^2 = [1 + 7 \cdot 0,369] \cdot 1,25 / 2 \cdot 18,99^2 \cdot 10^{-3} = 0,79 \text{ kN/m}^2$$

Prikaz djelovanja vjetra na krovnu plohu:

Proračun koeficijenata pritiska  $c_{pe}$ ,  $c_{pi}$



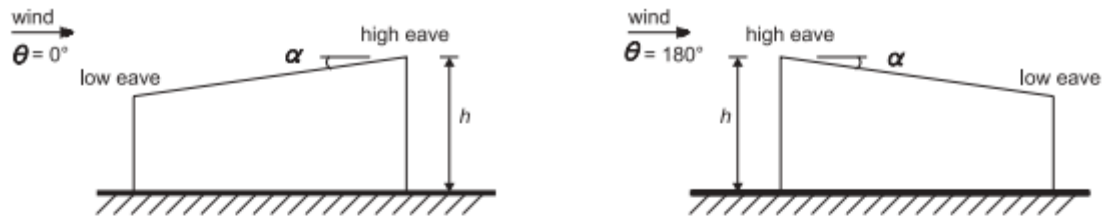

(a) general

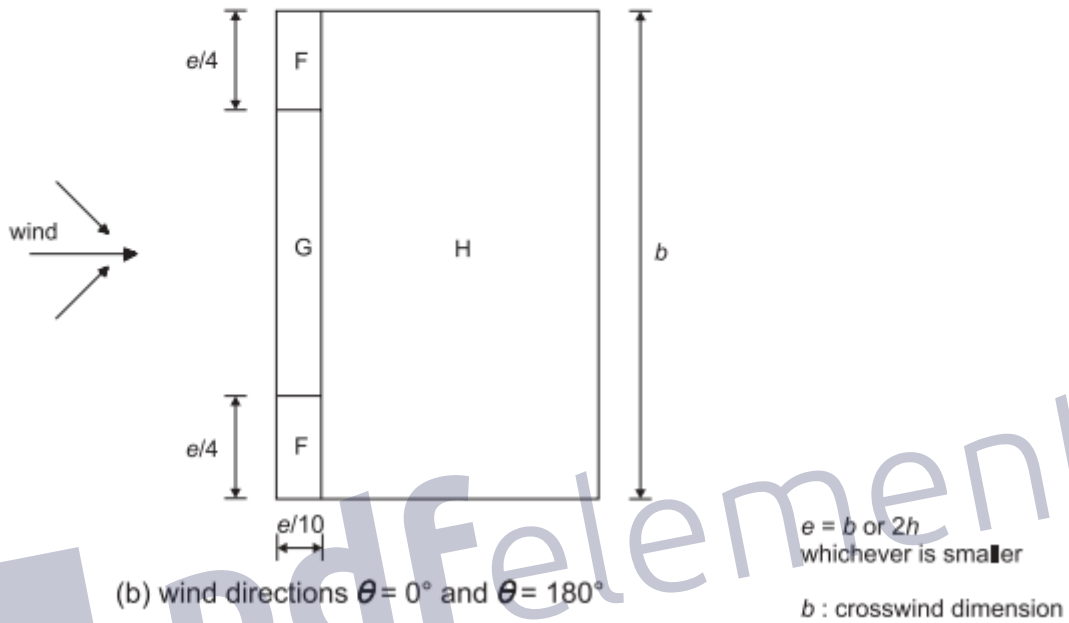

(b) wind directions  $\theta = 0^\circ$  and  $\theta = 180^\circ$

Slika 14: Djelovanje vjetra na jednostrešne krovove

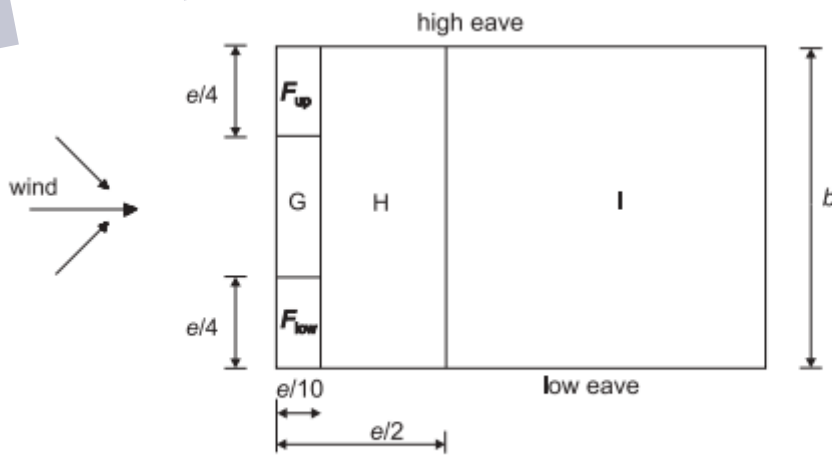

(c) wind direction  $\theta = 90^\circ$

Slika 15: Djelovanje vjetra na jedostrešne krovove

$$e = \min \{b, 2h\} = \min \{10,00 \cdot 6 = 60,0 \quad 2 \cdot 15,0 = 30,0\} = 30,0\text{m}$$

Jednostrešni krov, kut nagiba krova  $\alpha=30,0^\circ$

Table 7.3a — External pressure coefficients for monopitch roofs

Pitch Angle $\alpha$	Zone for wind direction $\theta = 0^\circ$						Zone for wind direction $\theta = 180^\circ$					
	F		G		H		F		G		H	
	$C_{pe,10}$	$C_{pe,1}$	$C_{pe,10}$	$C_{pe,1}$	$C_{pe,10}$	$C_{pe,1}$	$C_{pe,10}$	$C_{pe,1}$	$C_{pe,10}$	$C_{pe,1}$	$C_{pe,10}$	$C_{pe,1}$
5°	-1,7	-2,5	-1,2	-2,0	-0,6	-1,2	-2,3	-2,5	-1,3	-2,0	-0,8	-1,2
	+0,0		+0,0		+0,0							
15°	-0,9	-2,0	-0,8	-1,5	-0,3		-2,5	-2,8	-1,3	-2,0	-0,9	-1,2
	+0,2		+0,2		+0,2							
30°	-0,5	-1,5	-0,5	-1,5	-0,2		-1,1	-2,3	-0,8	-1,5	-0,8	
	+0,7		+0,7		+0,4							
45°	-0,0		-0,0		-0,0		-0,6	-1,3	-0,5		-0,7	
	+0,7		+0,7		+0,6							
60°	+0,7		+0,7		+0,7		-0,5	-1,0	-0,5		-0,5	
75°	+0,8		+0,8		+0,8		-0,5	-1,0	-0,5		-0,5	

Slika 16: Prikaz koeficijenta vanjskog tlaka za višestrešne „SHED“krovove

Table 7.3b — External pressure coefficients for monopitch roofs

Pitch Angle $\alpha$	Zone for wind direction $\theta = 90^\circ$									
	$F_{up}$		$F_{low}$		G		H		I	
	$C_{pe,10}$	$C_{pe,1}$	$C_{pe,10}$	$C_{pe,1}$	$C_{pe,10}$	$C_{pe,1}$	$C_{pe,10}$	$C_{pe,1}$	$C_{pe,10}$	$C_{pe,1}$
5°	-2,1	-2,6	-2,1	-2,4	-1,8	-2,0	-0,6	-1,2	-0,5	
15°	-2,4	-2,9	-1,6	-2,4	-1,9	-2,5	-0,8	-1,2	-0,7	-1,2
30°	-2,1	-2,9	-1,3	-2,0	-1,5	-2,0	-1,0	-1,3	-0,8	-1,2
45°	-1,5	-2,4	-1,3	-2,0	-1,4	-2,0	-1,0	-1,3	-0,9	-1,2
60°	-1,2	-2,0	-1,2	-2,0	-1,2	-2,0	-1,0	-1,3	-0,7	-1,2
75°	-1,2	-2,0	-1,2	-2,0	-1,2	-2,0	-1,0	-1,3	-0,5	

NOTE 1 At  $\theta = 0^\circ$  (see table a)) the pressure changes rapidly between positive and negative values around a pitch angle of  $\alpha = +5^\circ$  to  $+45^\circ$ , so both positive and negative values are given. For those roofs, two cases should be considered: one with all positive values, and one with all negative values. No mixing of positive and negative values is allowed on the same face.

NOTE 2 Linear interpolation for intermediate pitch angles may be used between values of the same sign. The values equal to 0.0 are given for interpolation purposes

Slika 17: Prikaz koeficijenta vanjskog tlaka za višestrešne „SHED“krovove

Za koeficijent unutarnjeg tlaka  $c_{pi}$  uzete su preporučene vrijednosti +0.2 i -0.3.

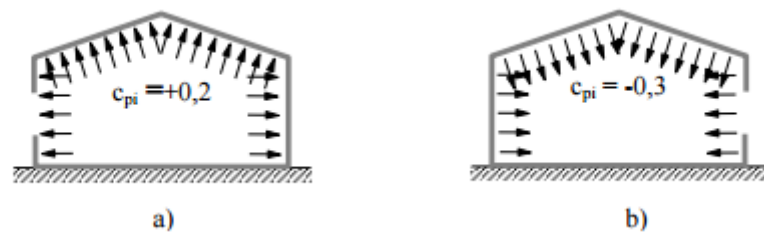

Slika 18: Prikaz koeficijenta unutrašnjeg tlaka

Oblik krova predviđen za konstrukciju društvenog centra je jednostrešni “shed” krov (multispan roof). Potrebno je uzeti u obzir redukciju vrijednosti koeficijenta vanjskog tlaka.

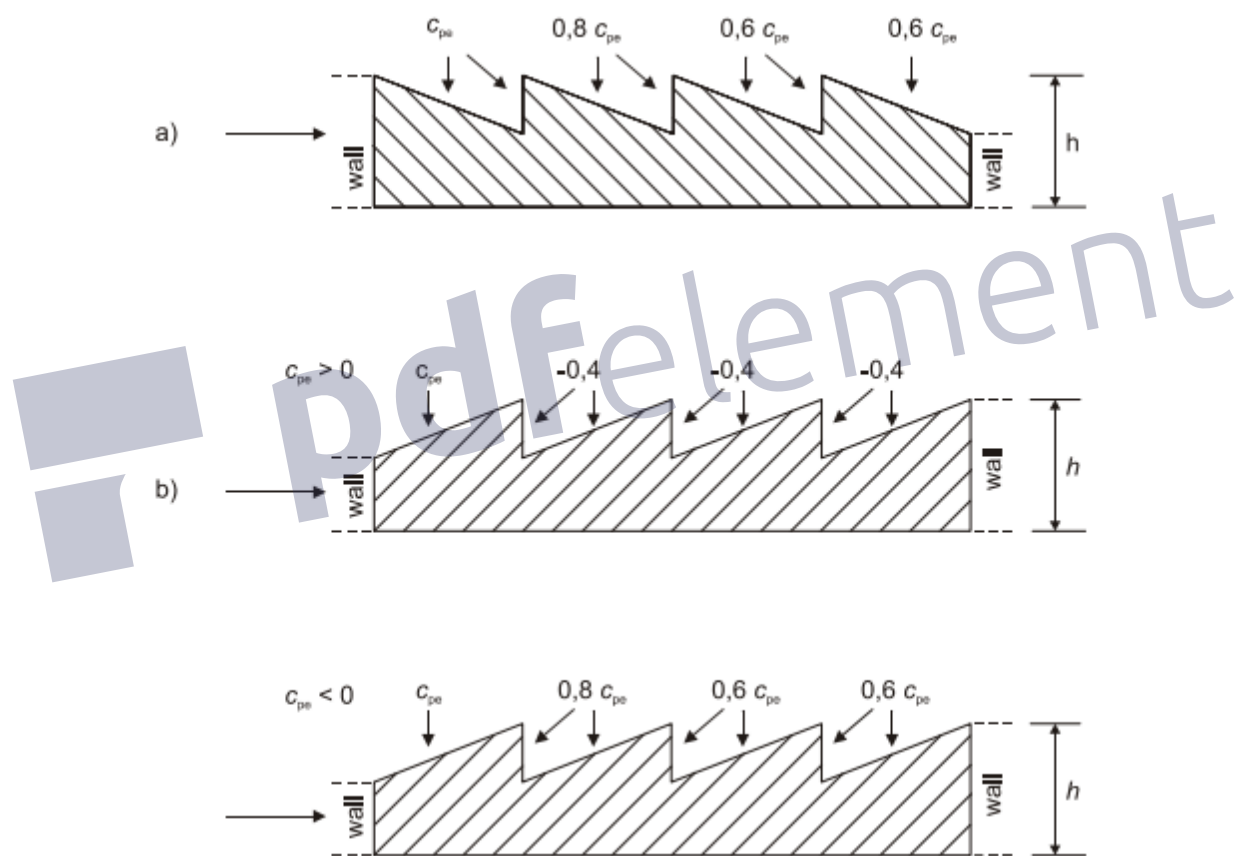

Slika 19: Prikaz redukcije koeficijenta vanjskog tlaka s obzirom na oblik krova

Pritisak vjetra na vanjske površine:  $w_e = q_p * c_{pe}$  [kN/m<sup>2</sup>]

KOMBINACIJA 1			
Područje	$q_p$ (kN/m <sup>2</sup> )	$c_{pe}$	$W_{e1}$ (kN/m <sup>2</sup> )
F	0.79	-1.5	-1.19
G	0.79	-1.5	-1.19
H(0.6)	0.79	-0.12	-0.09
H(0.8)	0.79	-0.16	-0.13

KOMBINACIJA 2			
Područje	$q_p$ (kN/m <sup>2</sup> )	$c_{pe}$	$W_{e2}$ (kN/m <sup>2</sup> )
F	0.79	0.7	0.55
G	0.79	0.7	0.55
H(0.6)	0.79	0.24	0.19
H(0.8)	0.79	0.32	0.25

Tablica 3. Vrijednosti vanjskog tlaka

Pritisak vjetra na unutarnje površine:  $w_i = q_p \cdot c_{pi}$  [kN/m<sup>2</sup>]

Područje	$q_p$ (kN/m <sup>2</sup> )	$c_{pi}$	$W_{i1}$ (kN/m <sup>2</sup> )
F	0.79	0.2	0.16
G	0.79	0.2	0.16
H	0.79	0.2	0.16

Područje	$q_p$ (kN/m <sup>2</sup> )	$c_{pi}$	$W_{i2}$ (kN/m <sup>2</sup> )
F	0.79	-0.3	-0.24
G	0.79	-0.3	-0.24
H	0.79	-0.3	-0.24

Tablica 4. Vrijednosti unutarnjeg tlaka

REZULTIRAJUĆE DJELOVANJE VJETRA(kN/m <sup>2</sup> )				
PODRUČJE	VJETAR 1= $W_{e1}+W_{i1}$	VJETAR 2= $W_{e1}+W_{i2}$	VJETAR 3= $W_{e2}+W_{i1}$	VJETAR 4= $W_{e2}+W_{i2}$
F	-1.34	-0.95	0.40	0.79
G	-1.34	-0.95	0.40	0.79
H(0.6)	-0.25	0.14	0.03	0.43
H(0.8)	-0.28	0.11	0.09	0.49

Tablica 5. Rezultirajuće vrijednosti pritiska vjetrom

Zbog specifičnog tipa krova djelovanje vjetra se prenosi na dijagonalni i vertikalni nosač krova. Djelovanje se u modelu nanosi linijski što će biti prikazano u sljedećim proračunima.

Djelovanje vjetra na krovnu konstrukciju

REZULTIRAJUĆE DJELOVANJE ZA VJETAR 1 (kN/m)				
PODRUČJE	L=5m	L=2.5m	SREDNJI NOSAČ	RUBNI NOSAČ
F	5	2.5	-6.72	-3.36
G	5	2.5	-6.72	-3.36
H(0.6)	5	2.5	-1.26	-0.63
H(0.8)	5	2.5	-1.42	-0.71

REZULTIRAJUĆE DJELOVANJE ZA VJETAR 2 (kN/m)				
PODRUČJE	L=5.0m	L=2.5m	SREDNJI NOSAČ	RUBNI NOSAČ
F	5	2.5	-4.74	-2.37
G	5	2.5	-4.74	-2.37
H(0.6)	5	2.5	0.71	0.36
H(0.8)	5	2.5	0.55	0.28

REZULTIRAJUĆE DJELOVANJE ZA VJETAR 3 (kN/m)				
PODRUČJE	L=5.0m	L=2.5m	SREDNJI NOSAČ	RUBNI NOSAČ
F	5	2.5	1.98	0.99
G	5	2.5	1.98	0.99
H(0.6)	5	2.5	0.16	0.08
H(0.8)	5	2.5	0.47	0.24

REZULTIRAJUĆE DJELOVANJE ZA VJETAR 4 (kN/m)				
PODRUČJE	L=5.0m	L=2.5m	SREDNJI NOSAČ	RUBNI NOSAČ
F	5	2.5	3.95	1.98
G	5	2.5	3.95	1.98
H(0.6)	5	2.5	2.13	1.07
H(0.8)	5	2.5	2.45	1.22

Tablica 6. Rezultirajuće vrijednosti opterećenja vjetrovom

Za daljni proračun u obzir će se uzeti vrijednosti za VJETAR 1 (Tablica 6.) koji će se u kombinacijama opterećenja označavati s W1 i VJETAR 4 (Tablica 6.) koji će se u kombinacijama opterećenja označavati s W2.

Djelovanje vjetra na zidove konstrukcije

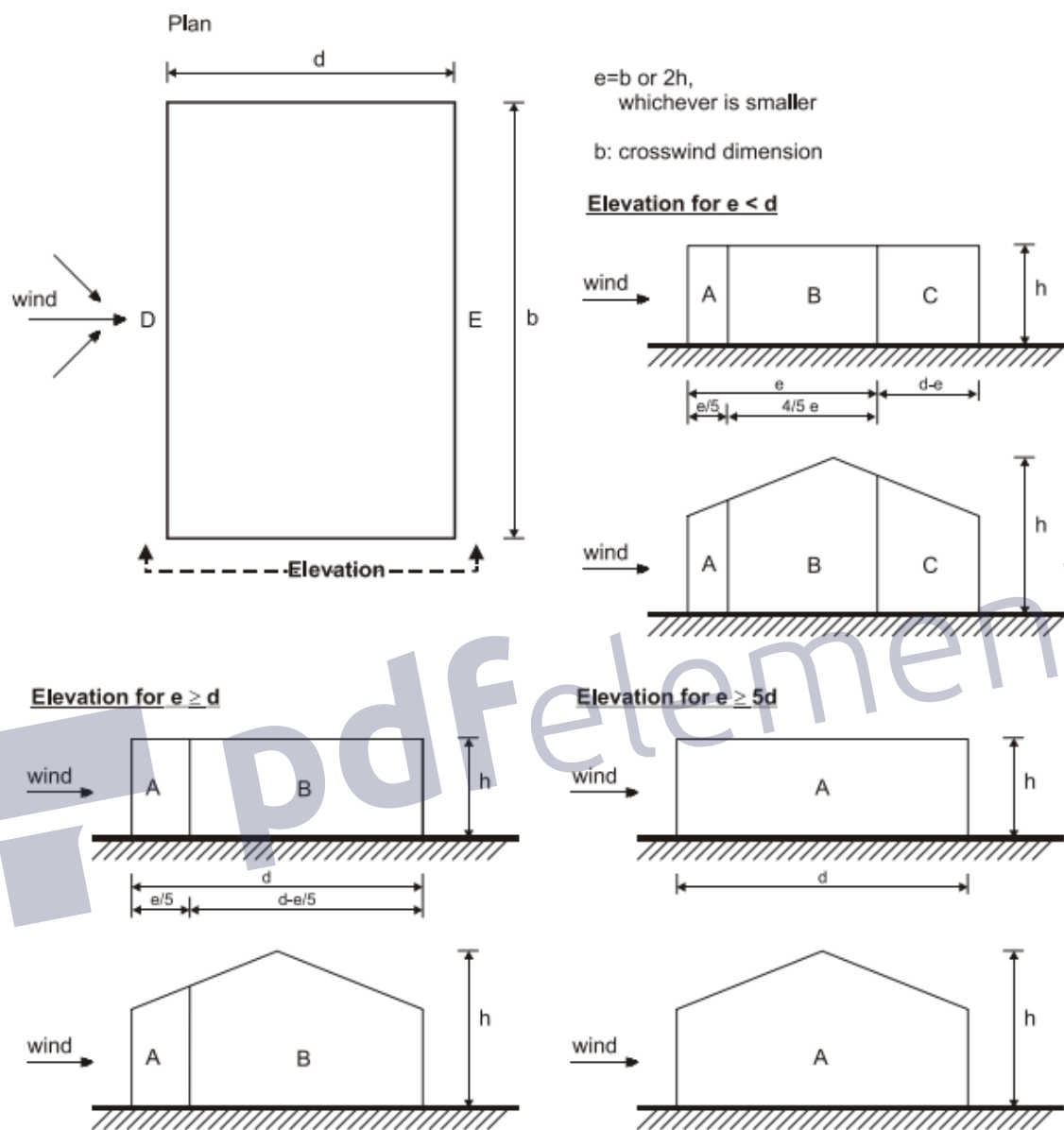

Slika 20: Prikaz djelovanja vjetra na zidove

$$e = \min \{b, 2h\} = \min \{10,00 \cdot 6 = 60,0 \quad 2 \cdot 15,0 = 30,0\} = 30,0\text{m}$$

Područje	$q_p(\text{kN/m}^2)$	$c_{pe}$	$W_e(\text{kN/m}^2)$
D	0.79	1	0.79
E	0.79	-0.5	-0.40

Tablica 7. Prikaz vrijednosti vanjskog tlaka

Područje	$q_p$ (kN/m <sup>2</sup> )	$c_{pi}$	$W_{i1}$ (kN/m <sup>2</sup> )
D	0.79	0.2	0.16
E	0.79	0.2	0.16

Područje	$q_p$ (kN/m <sup>2</sup> )	$c_{pi}$	$W_{i2}$ (kN/m <sup>2</sup> )
D	0.79	-0.3	-0.24
E	0.79	-0.3	-0.24

Tablica 8. Prikaz vrijednosti unutrašnjeg tlaka

REZULTIRAJUĆE DJELOVANJE VJETRA(kN/m <sup>2</sup> )		
Područje	VJETAR 1= $W_e+W_{i1}$	VJETAR 2= $W_e+W_{i2}$
D	0.63	1.03
E	-0.55	-0.16

REZULTIRAJUĆE DJELOVANJE ZA VJETAR 1(kN/m)				
Područje	L=10.0 m	SREDNJI DIO	L=5.0 m	RUBNI DIO
D	10.00	6.32	5.00	3.16
E	10.00	-5.53	5.00	-2.77

REZULTIRAJUĆE DJELOVANJE ZA VJETAR 2(kN/m)				
Područje	L=10.00 m	SREDNJI DIO	L=5.0 m	RUBNI DIO
D	10.00	10.27	5.00	5.14
E	10.00	-1.58	5.00	-0.79

Tablica 9. Rezultirajuće vrijednosti opterećenja vjetrom

Za daljni proračun u obzir će se uzeti vrijednosti za VJETAR 2 (Tablica 9.)

Djelovanje vjetra na zabatni zid :

Područje	$q_p$ (kN/m <sup>2</sup> )	$c_{pe}$	$W_e$ (kN/m <sup>2</sup> )
A	0.79	-1.4	-1.11
B	0.79	-1.1	-0.87
C	0.79	-0.5	-0.40

Tablica 10. Prikaz vrijednosti vanjskog tlaka

Područje	$q_p$ (kN/m <sup>2</sup> )	$c_{pi}$	$W_{i1}$ (kN/m <sup>2</sup> )
A	0.79	0.2	0.16
B	0.79	0.2	0.16
C	0.79	0.2	0.16

Područje	$q_p$ (kN/m <sup>2</sup> )	$c_{pi}$	$W_{i2}$ (kN/m <sup>2</sup> )
A	0.79	-0.3	-0.24
B	0.79	-0.3	-0.24
C	0.79	-0.3	-0.24

Tablica 11. Prikaz opterećenja unutrašnjeg tlaka

REZULTIRAJUĆE DJELOVANJE VJETRA(kN/m <sup>2</sup> )				
PODRUČJE	VJETAR 1=	$W_e+W_{i1}$	VJETAR 2=	$W_e-W_{i2}$
A		-1.26		-0.87
B		-1.03		-0.63
C		-0.55		-0.16

Tablica 12. Rezultirajuće vrijednosti opterećenja vjetrom

REZULTIRAJUĆE DJELOVANJE ZA VJETAR 1 (kN/m)				
PODRUČJE	L=4m	RUBNI STUP	L=8m	SREDNJI STUP
A	4	-5.06	8	-10.11
B	4	-4.11	8	-8.22
C	4	-2.21	8	-4.42

Tablica 13. Prikaz vrijednosti opterećenja vjetrom na konstrukciju



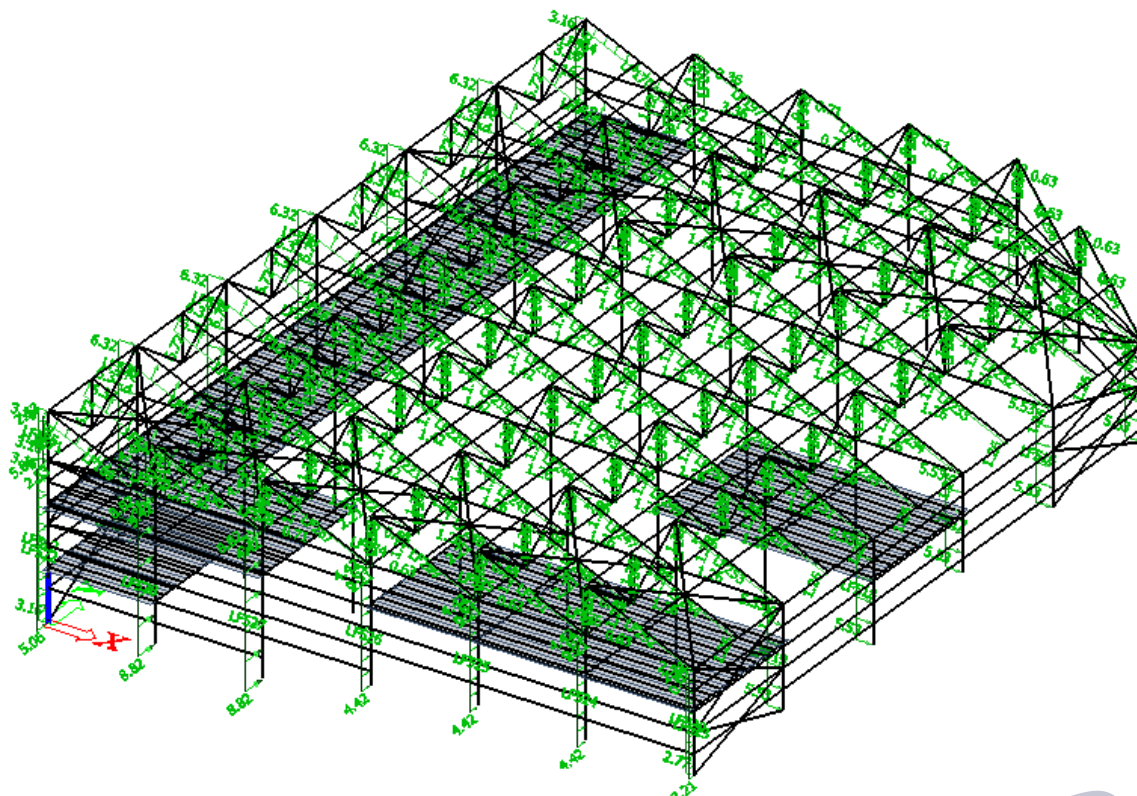

Slika 21: Prikaz djelovanja vjetra na konstrukciju(W1)

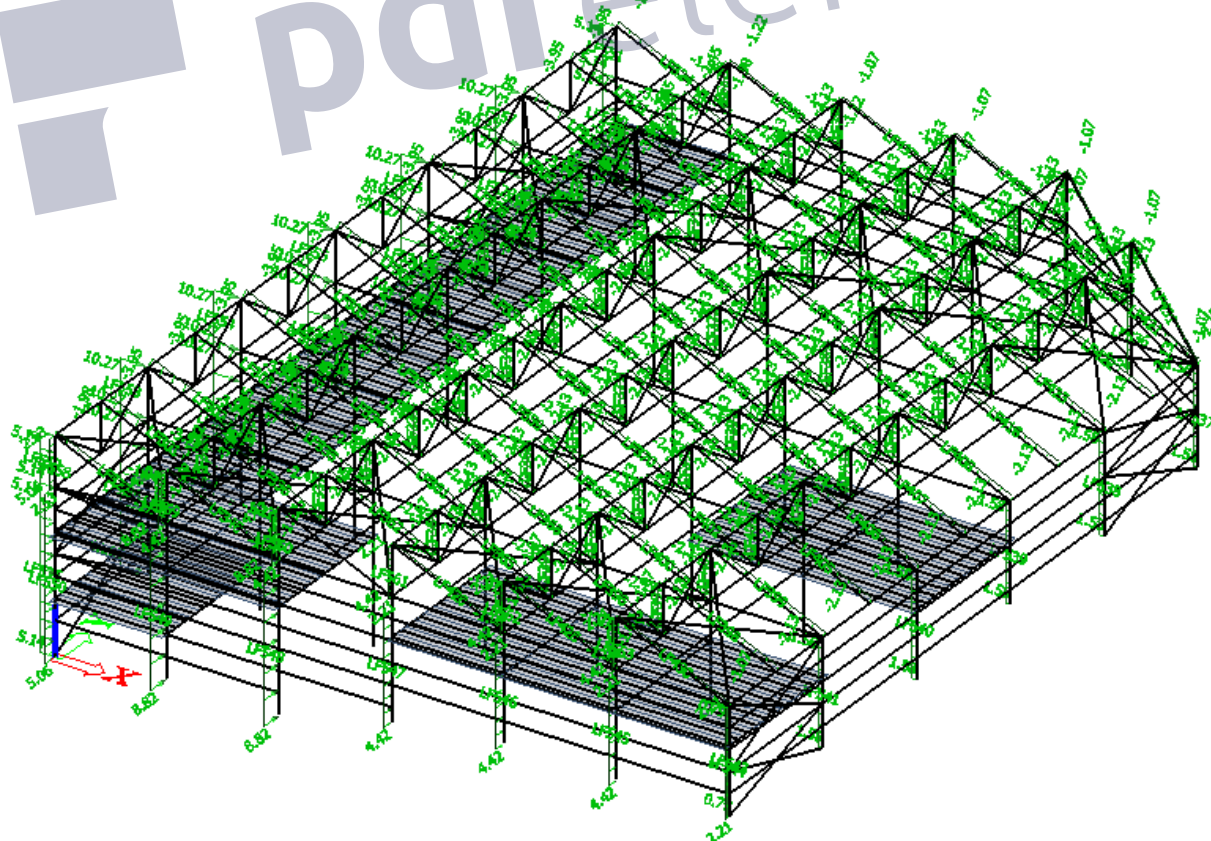

Slika 22: Prikaz djelovanja vjetra na konstrukciju(W2)

### 3.6 Promijenjivo djelovanje –trenjem po krovu

$$F_{fr} = c_{fr} \cdot q_p(z) \cdot A_{fr} - \text{sila trenja}$$

$c_{fr} = 0,04$  - koef. trenja za narebreni lim (vjerojatni pokrov)

$q_p(z)$  - osnovni pritisak vjetra

$A_{fr}$  - površina usporedno sa smjerom vjetra

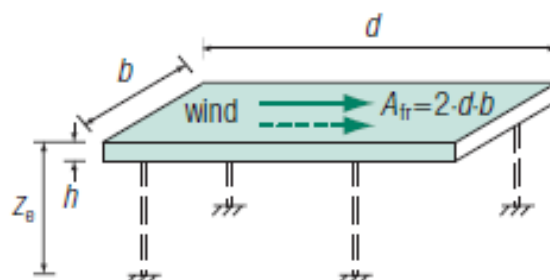

Slika 23: Prikaz djelovanja trenja po površini

Referentna površina:

Referentna površina za dijagonalnu krovnu plohu:

$$A_{fr} = 2 \cdot b \cdot d = 2 \cdot 8.732 \cdot 60 \text{ m} = 1047 \text{ m}^2$$

$$F_{fr} = 0,04 \cdot 0,79 \cdot 1047 = 33,0852 \text{ kN}$$

Referentna površina za vertikalnu krovnu plohu:

$$A_{fr} = 2 \cdot b \cdot d = 2 \cdot 3.50 \cdot 60 \text{ m} = 420 \text{ m}^2$$

$$F_{fr} = 0,04 \cdot 0,79 \cdot 420 = 13,272 \text{ kN}$$

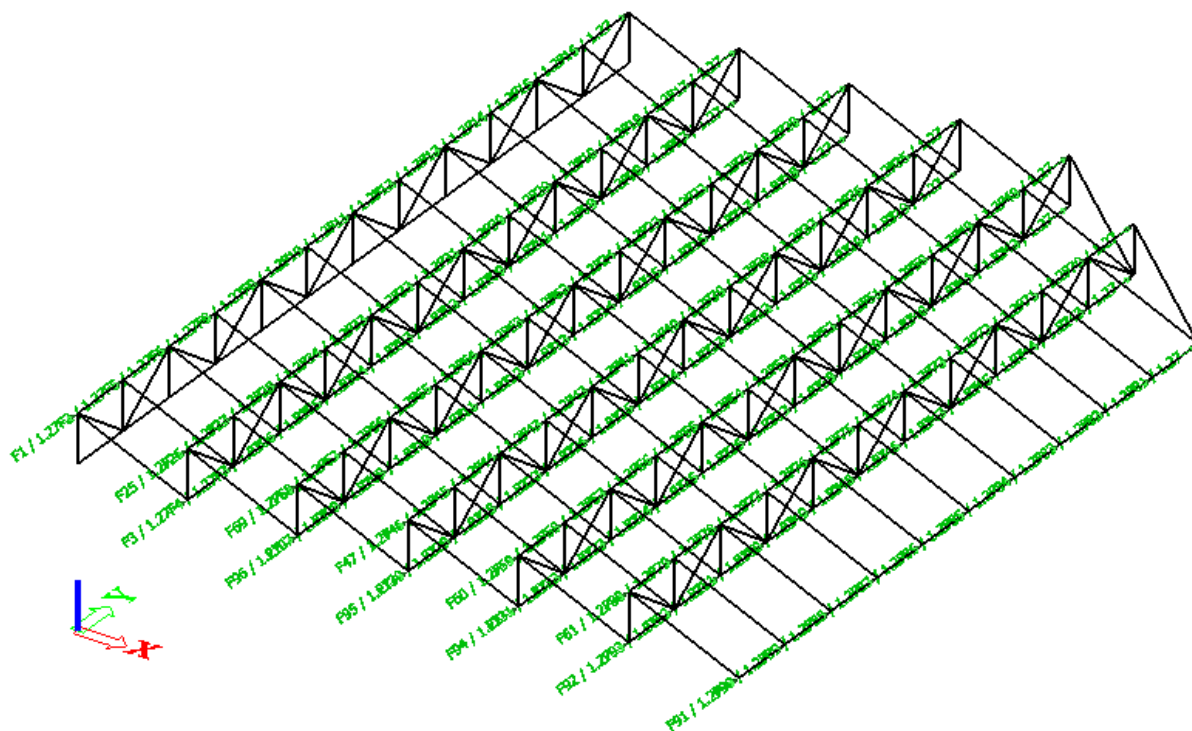

Slika 24: Prikaz opterećenja trenjem na krovnu konstrukciju

pdfelement

### 3.7 Promjenjivo djelovanje –temperatura

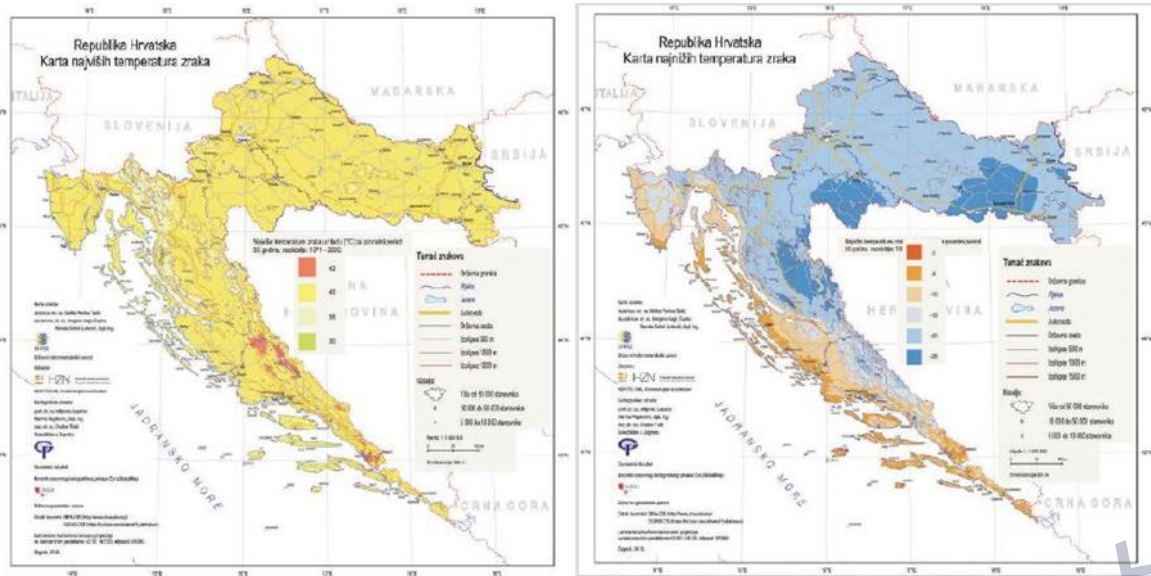

Slika 25: Karta opterećenja temperaturom

Promatrani objekt nalazi se u IV. Području, do 100 m nadmorske visine:

Najviša temperatura u hladu:  $T_{\max} = 42^{\circ}\text{C}$

Najniža temperatura u hladu:  $T_{\min} = -10^{\circ}\text{C}$

Pretpostavlja se djelovanje jednolike temperature promjene u svim presjecima.

Pretpostavljena temperatura pri montaži konstrukcije  $T = 12^{\circ}\text{C}$

- 1) Maksimalna pozitivna temperaturna promjena:  $T_{\max} = 42^{\circ}\text{C} - 12^{\circ}\text{C} = 30^{\circ}\text{C}$
- 2) Maksimalna negativna temperaturna promjena:  $T_{\min} = -10^{\circ}\text{C} - 12^{\circ}\text{C} = -22^{\circ}\text{C}$

Temperatura pozitivna:

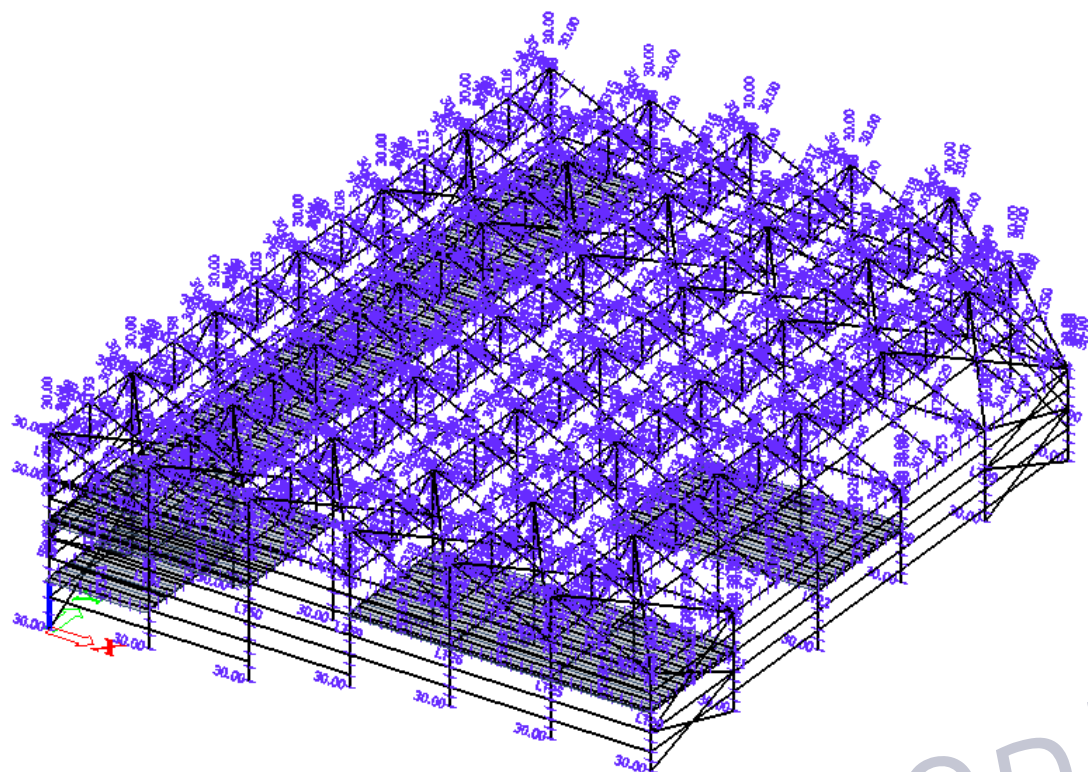

Slika 26: Prikaz opterećenja temperaturom

Temperatura negativna:

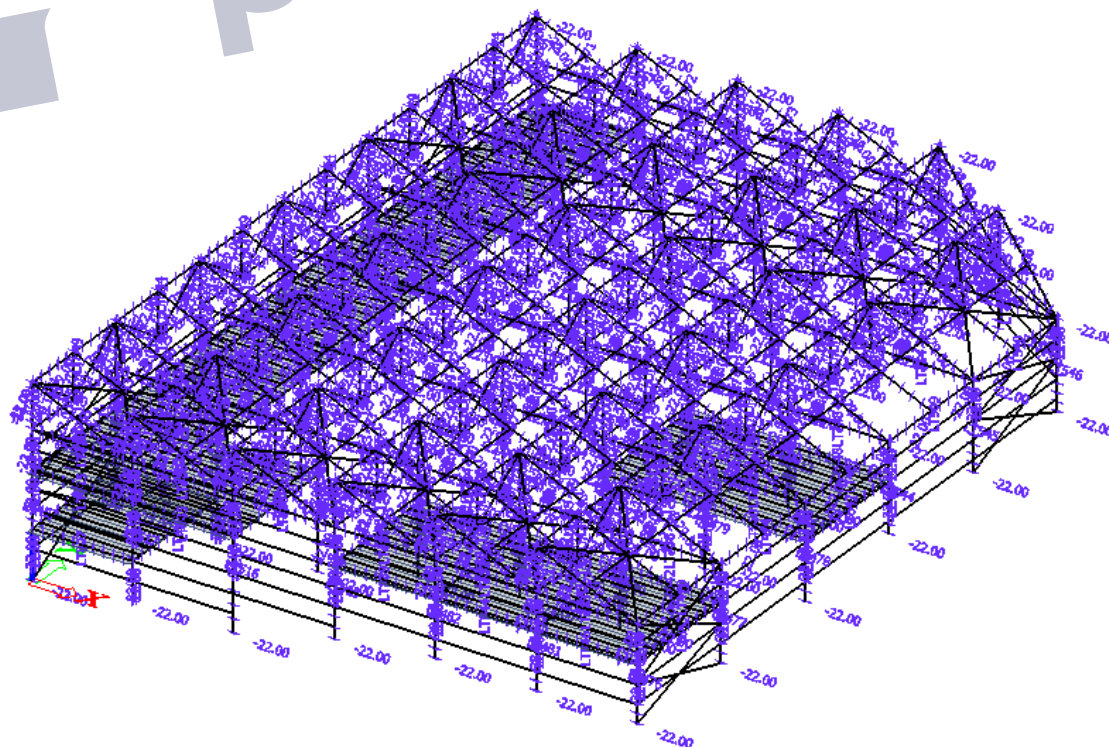

Slika 27: Prikaz opterećenja temperaturom

### 3.8 Kombinacije djelovanja

Kombinacije djelovanja izrađene su za krajnje granično stanje i granično stanje uporabljivosti.

#### Combinations

Name	Type	Load cases	Coeff. [-]
<i>*Student version*</i>			
GSN 1	Envelope - ultimate	Vlastita teжина	1.35
		dodatno stalno	1.35
		korisno opterećenje međukatne	1.35
		snijeg 1	1.50
		vjetar 1 (odize)	0.90
		temperatura negativna	0.90
		trenjem po krovu	0.90
		GSN 2	Envelope - ultimate
dodatno stalno	1.35		
korisno opterećenje međukatne	1.35		
snijeg 2	1.50		
vjetar 1 (odize)	0.90		
temperatura negativna	0.90		
trenjem po krovu	0.90		
GSN 3	Envelope - ultimate		
		dodatno stalno	1.35
		korisno opterećenje međukatne	1.35
		snijeg 2	0.90
		vjetar 1 (odize)	1.50
		temperatura negativna	0.90
		trenjem po krovu	0.90
		GSN 4	Envelope - ultimate
dodatno stalno	1.35		
korisno opterećenje međukatne	1.35		
snijeg 2	0.90		
vjetar 2	1.50		
temperatura negativna	0.90		
trenjem po krovu	0.90		

GSN 5	Envelope - ultimate	Vlastita tezina	1.35
		dodatno stalno	1.35
		korisno opterećenje međukatne	1.35
		snijeg 1	0.90
		vjetar 2	1.50
		temperatura negativna	0.90
		trenjem po krovu	0.90
GSN 6	Envelope - ultimate	Vlastita tezina	1.35
		dodatno stalno	1.35
		korisno opterećenje međukatne	1.35
		snijeg 1	1.50
		temperatura negativna	0.90
GSN 7	Envelope - ultimate	Vlastita tezina	1.35
		dodatno stalno	1.35
		korisno opterećenje međukatne	1.35
		snijeg 2	1.50
		temperatura negativna	0.90
GSN 8	Envelope - ultimate	Vlastita tezina	1.35
		dodatno stalno	1.35
		korisno opterećenje međukatne	1.35
		vjetar 1 (odize)	1.50
		temperatura pozitivna	0.90
		trenjem po krovu	0.90
GSN 9	Envelope - ultimate	Vlastita tezina	1.35
		dodatno stalno	1.35
		korisno opterećenje međukatne	1.35
		vjetar 2	1.50
		temperatura pozitivna	0.90
		trenjem po krovu	0.90
GSN 10	Envelope - ultimate	Vlastita tezina	1.35
		dodatno stalno	1.35
		korisno opterećenje međukatne	1.35
		temperatura negativna	1.50
GSN 11	Envelope - ultimate	Vlastita tezina	1.35
		dodatno stalno	1.35
		korisno opterećenje međukatne	1.35
		temperatura pozitivna	1.50
GSN 12	Envelope - ultimate	Vlastita tezina	1.35
		dodatno stalno	1.35
		korisno opterećenje međukatne	1.35
		vjetar 2	1.50
		temperatura negativna	0.90
		trenjem po krovu	0.90

GSU 1	Envelope - ultimate	Vlastita tezina	1.00
		dodatno stalno	1.00
		korisno opterećenje međukatne snijeg 2	1.00
		vjetar 1 (odize)	1.00
		temperatura negativna	1.00
		trenjem po krovu	1.00
		GSU 2	Envelope - ultimate
		dodatno stalno	1.00
		korisno opterećenje međukatne snijeg 2	1.00
		vjetar 2	1.00
		temperatura negativna	1.00
		trenjem po krovu	1.00
GSU 3	Envelope - ultimate	Vlastita tezina	1.00
		dodatno stalno	1.00
		korisno opterećenje međukatne snijeg 1	1.00
		temperatura negativna	1.00
GSU 4	Envelope - ultimate	Vlastita tezina	1.00
		dodatno stalno	1.00
		korisno opterećenje međukatne snijeg 2	1.00
		temperatura negativna	1.00
		GSU 5	Envelope - ultimate
		dodatno stalno	1.00
		korisno opterećenje međukatne vjetar 1 (odize)	1.00
		temperatura pozitivna	1.00
		trenjem po krovu	1.00
GSU 6	Envelope - ultimate	Vlastita tezina	1.00
		dodatno stalno	1.00
		korisno opterećenje međukatne vjetar 2	1.00
		temperatura pozitivna	1.00
		trenjem po krovu	1.00



## 4. DIMENZIONIRANJE ELEMENATA KONSTRUKCIJE

### 4.1 Pomaci konstrukcije

Vertikalni progib krovne rešetkaste konstrukcije:

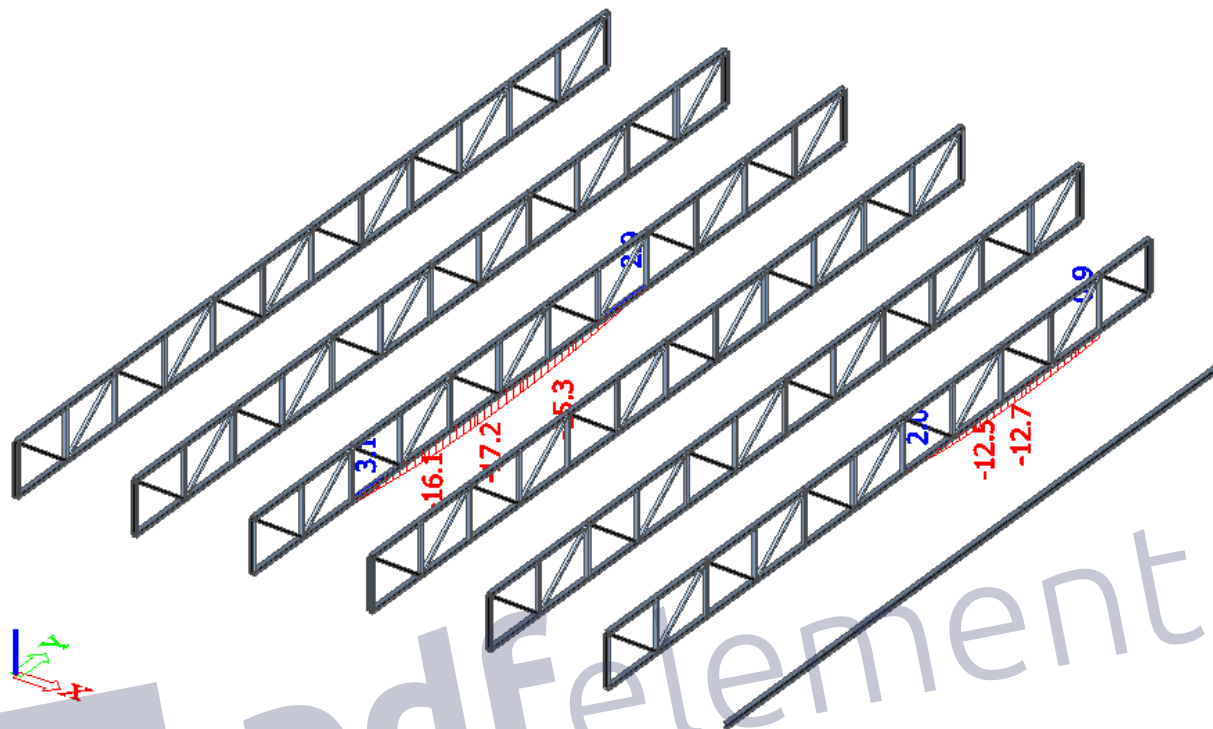

Slika 28: Vertikalni progib krovne konstrukcije

Progib kose krovne grede koji utjece na funkcionalnost korištenja prostora

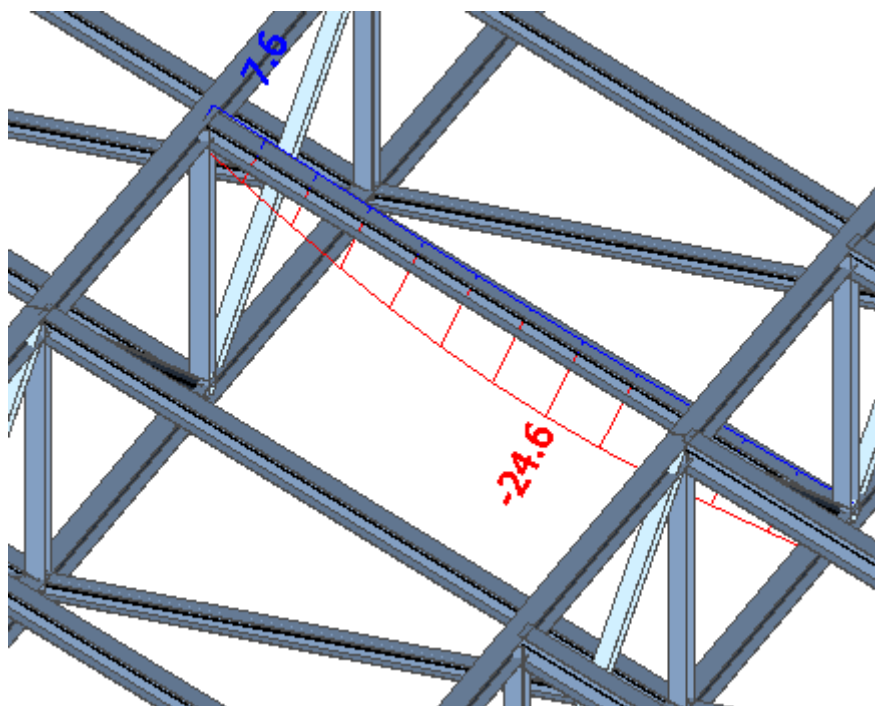

Dopušteni vertikalni pomak(krovna konstrukcija):

$$u_{dop} = \frac{l}{300} = \frac{8.734 \cdot 1000}{300} = 29.11 \text{ mm}$$

$$u_z = 24.73 \text{ mm} < u_{z,dop} = 29.11 \text{ mm} \quad \text{Zadovoljava}$$

Horizontalni pomak krovne rešetkaste konstrukcije(vertikalna ispuna)

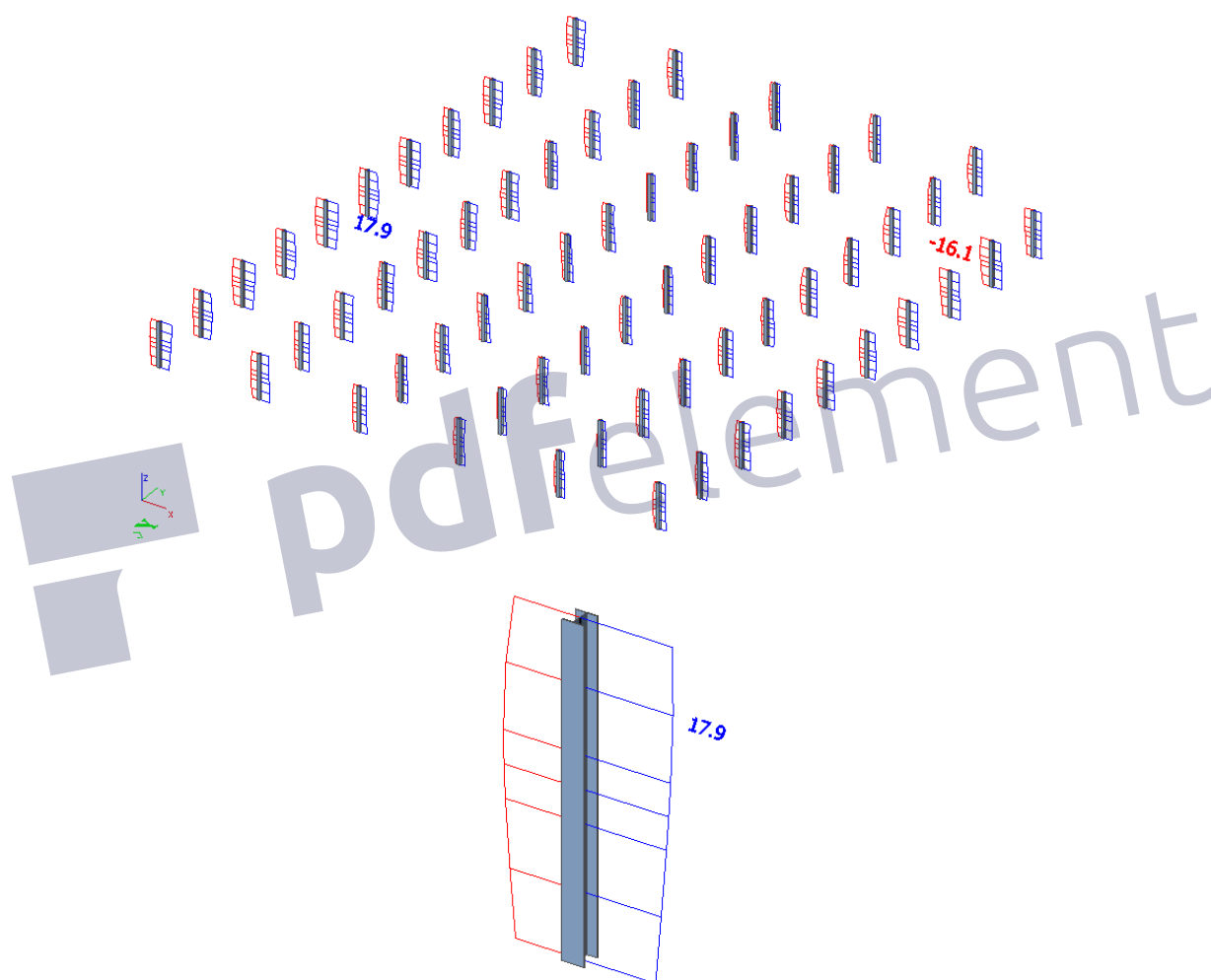

Slika 29: Horizontalni progib ispune krovne rešetke

## Horizontalni pomak stupova

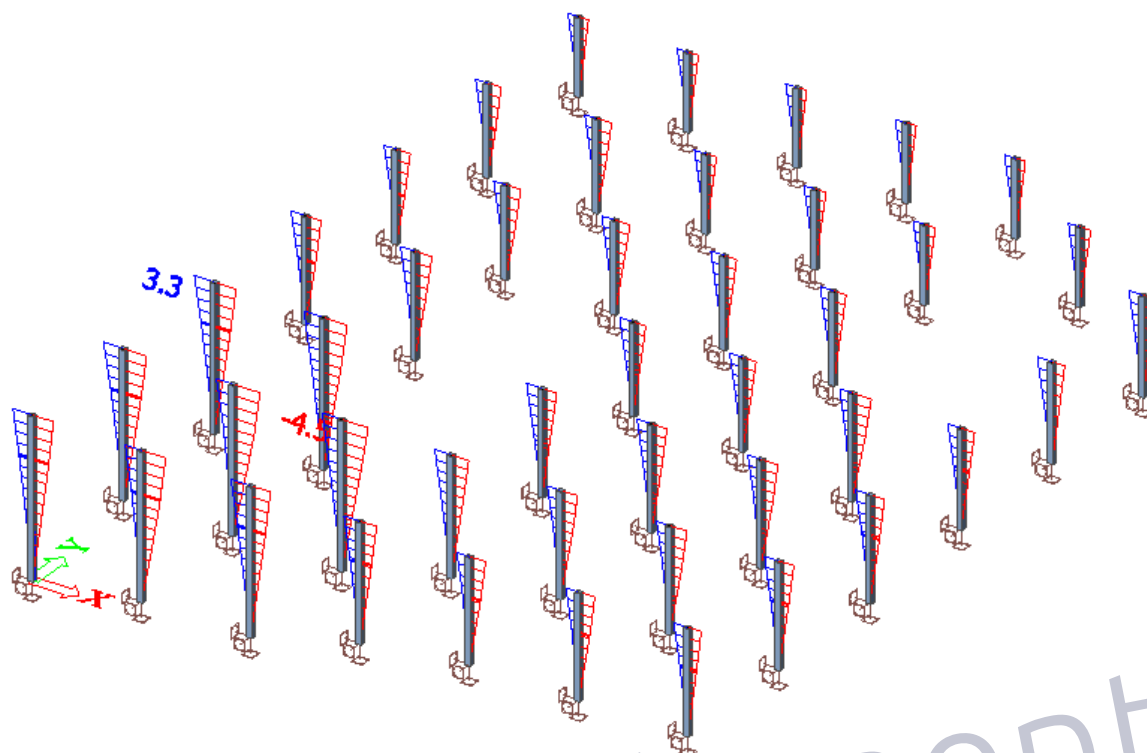

Slika 30: Horizontalni progib stupova

Dopušteni horizontalni pomak stupova:

$$u_{dop} = \frac{h}{200} = \frac{11.5 \cdot 1000}{200} = 57,5 \text{ mm}$$

$$u_z = 4,5 \text{ mm} < u_{x,dop} = 57,5 \text{ mm} \quad \text{Zadovoljava}$$

Dopušteni horizontalni pomak krovne konstrukcije:

$$u_{dop} = \frac{h}{200} = \frac{3.5 \cdot 1000}{150} = 23,3 \text{ mm}$$

$$u_z = 18,6 \text{ mm} < u_{x,dop} = 23,3 \text{ mm} \quad \text{Zadovoljava}$$

## 4.2 Dimenzioniranje stupa

Dimenzioniranje konstrukcijskih elemenata je provedena softverom Scia Engineer 2016 pomoću modula Steel.

Uzdužna sila u stupu (N)

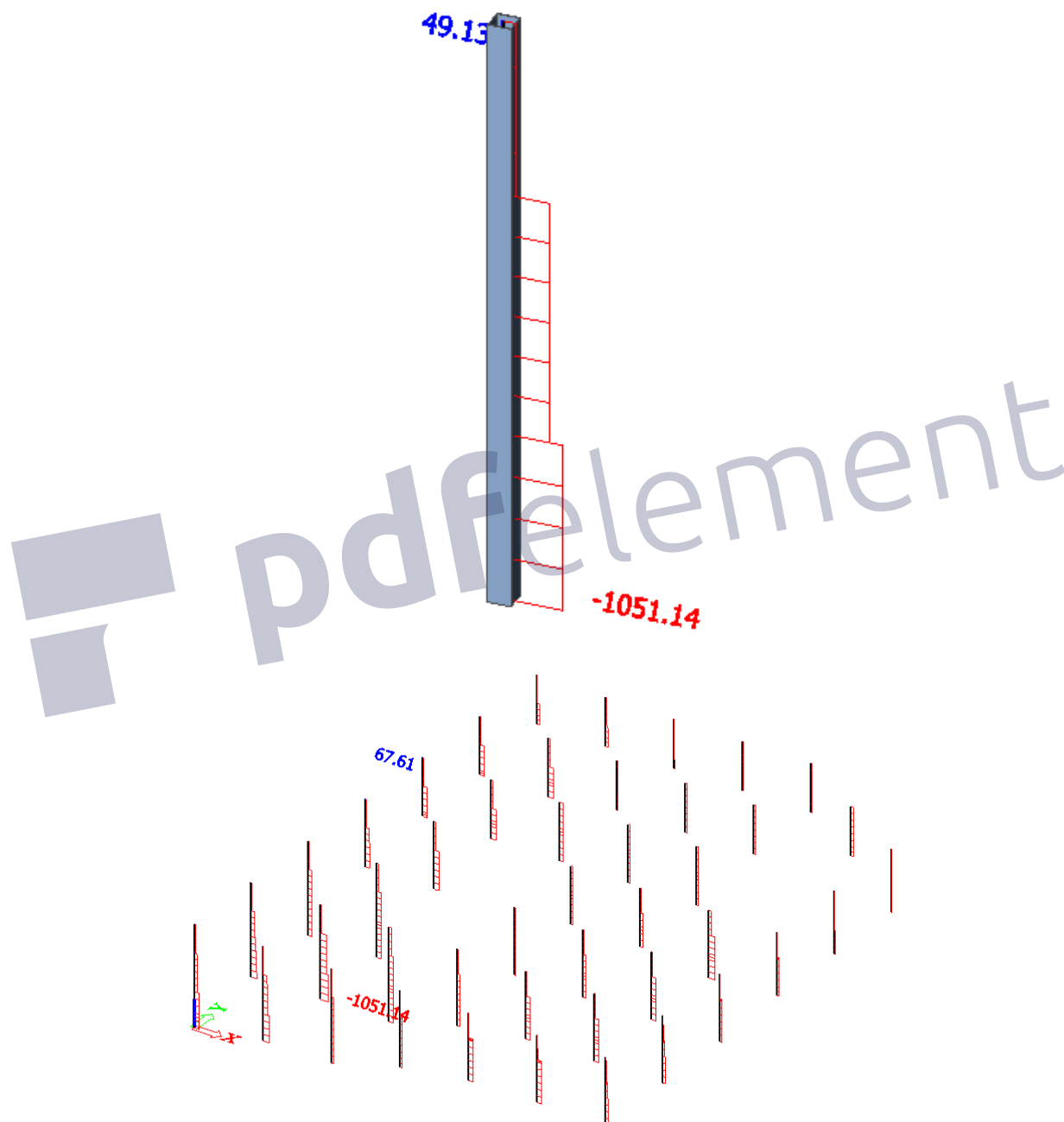

Slika 31: Vrijednosti uzdužne sile u stupovima

Poprečna sila u stupu ( $V_y$ )

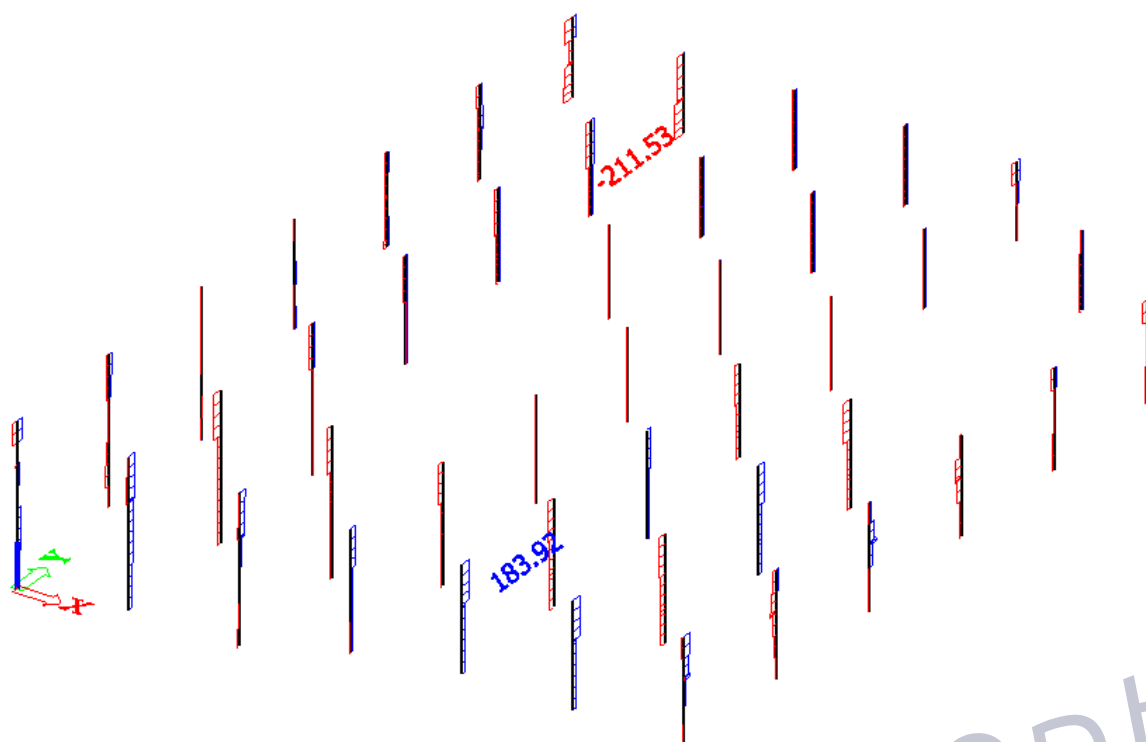

Slika 32: Vrijednosti poprečne sile u stupovima

Moment savijanja u stupu ( $M_z$ )

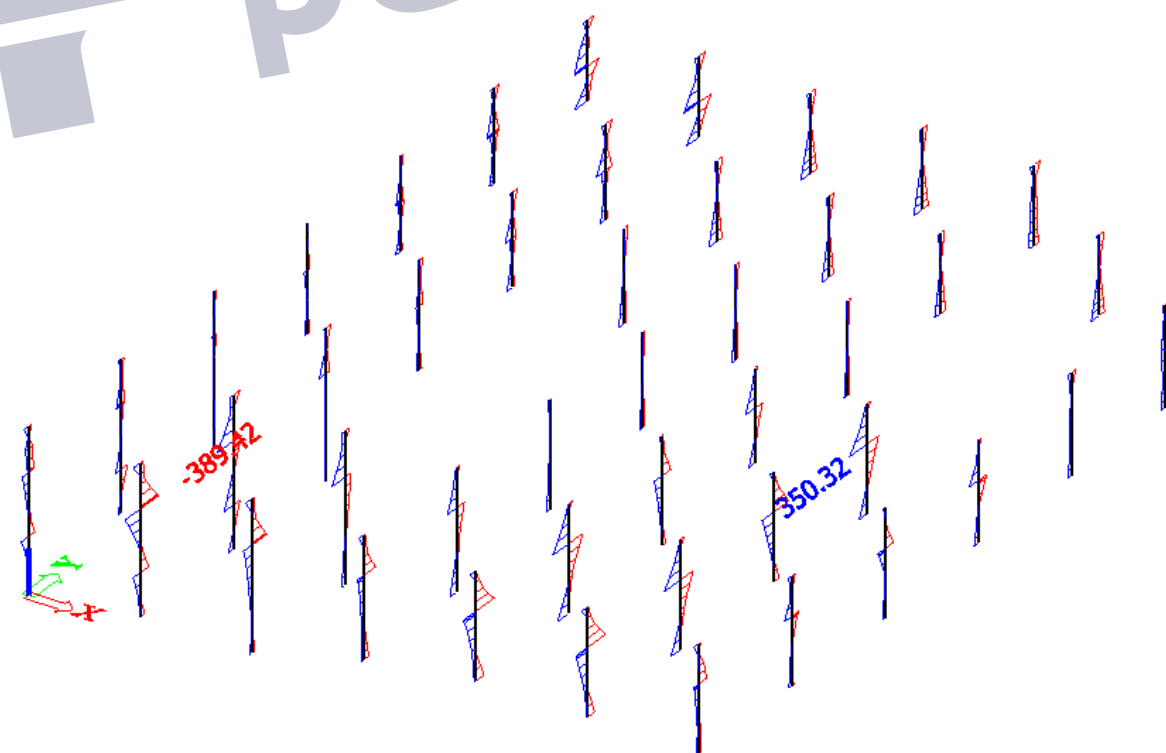

Slika 33: Vrijednosti momenta savijanja u stupovima

Prikaz iskoristivosti elementa



Slika 34: Prikaz iskoristivosti stupova

Poprečni presjek elementa

Name	CS9
Type	F400X10
Source description	Standard / GB 6728-2002
Item material	S 275
Fabrication	cold formed
Flexural buckling y-y	c
Flexural buckling z-z	c
Lateral torsional buckling	Default
Use 2D FEM analysis	x

A [m <sup>2</sup> ]	1.5300e-02	
A <sub>y, z</sub> [m <sup>2</sup> ]	7.6251e-03	7.6251e-03
I <sub>y, z</sub> [m <sup>4</sup> ]	3.8216e-04	3.8216e-04
I <sub>w</sub> [m <sup>6</sup> ], t [m <sup>4</sup> ]	8.5333e-06	6.0431e-04
W <sub>el y, z</sub> [m <sup>3</sup> ]	1.9110e-03	1.9110e-03
W <sub>pl y, z</sub> [m <sup>3</sup> ]	2.2137e-03	2.2137e-03
d <sub>y, z</sub> [mm]	0	0
c <sub>YUCS, ZUCS</sub> [mm]	200	200
α [deg]	0.00	
A <sub>L, D</sub> [m <sup>2</sup> /m]	1.5571e+00	3.0510e+00
M <sub>ply +, -</sub> [Nm]	6.08e+05	6.08e+05
M <sub>plz +, -</sub> [Nm]	6.08e+05	6.08e+05

Dimenzioniranje elementa je provedeno u softveru (modul Steel)

<b>Member B28</b>	<b>7.500 m</b>	<b>F400X10</b>	<b>S 275</b>	<b>GSN 3</b>	<b>0.92 -</b>
-------------------	----------------	----------------	--------------	--------------	---------------

Partial safety factors	
<i>*Student version* *Student version* *Student version* *Student version* *</i>	
Gamma M0 for resistance of cross-sections	1.00
Gamma M1 for resistance to instability	1.00
Gamma M2 for resistance of net sections	1.25

Material		
<i>*Student version* *Student version* *Student version* *Student version* *</i>		
Yield strength f <sub>y</sub>	275.0	MPa
Ultimate strength f <sub>u</sub>	430.0	MPa
Fabrication	Cold formed	

...:SECTION CHECK:....

The critical check is on position 4.750 m

Internal forces	Calculated	Unit
<i>*Student version* *Student version* *Student version* *Student version* *</i>		
N,Ed	-567.95	kN
V <sub>y</sub> ,Ed	-108.35	kN
V <sub>z</sub> ,Ed	54.88	kN
T,Ed	1.62	kNm
M <sub>y</sub> ,Ed	126.08	kNm
M <sub>z</sub> ,Ed	-299.89	kNm

**Classification for cross-section design**

According to EN 1993-1-1 article 5.5.2

**Classification of Internal Compression parts**

According to EN 1993-1-1 Table 5.2 Sheet 1

Maximum width-to-thickness ratio	37.00
Class 1 Limit	30.51
Class 2 Limit	35.13
Class 3 Limit	46.11

=&gt; Section classified as Class 3 for cross-section design

**Compression check**

According to EN 1993-1-1 article 6.2.4 and fomula (6.9)

A	1.5300e-02	m <sup>2</sup>
N <sub>c,Rd</sub>	4207.50	kN
Unity check	0.13	-

**Bending moment check for My**

According to EN 1993-1-1 article 6.2.5 and fomula (6.12),(6.14)

W <sub>el,y,min</sub>	1.9110e-03	m <sup>3</sup>
M <sub>el,y,Rd</sub>	525.52	kNm
Unity check	0.24	-

**Bending moment check for Mz**

According to EN 1993-1-1 article 6.2.5 and fomula (6.12),(6.14)

W <sub>el,z,min</sub>	1.9110e-03	m <sup>3</sup>
M <sub>el,z,Rd</sub>	525.52	kNm
Unity check	0.57	-

**Shear check for Vy**

According to EN 1993-1-1 article 6.2.6 and fomula (6.17)

Eta	1.20	
A <sub>v</sub>	7.6500e-03	m <sup>2</sup>
V <sub>pl,y,Rd</sub>	1214.60	kN
Unity check	0.09	-

**Shear check for Vz**

According to EN 1993-1-1 article 6.2.6 and fomula (6.17)

Eta	1.20	
A <sub>v</sub>	7.6500e-03	m <sup>2</sup>
V <sub>pl,z,Rd</sub>	1214.60	kN
Unity check	0.05	-



**Torsion check**

According to EN 1993-1-1 article 6.2.7 and fomula (6.23)

Tau,t,Ed	0.5	MPa
Tau,Rd	158.8	MPa
Unity check	0.00	-

**Note:** The unity check for torsion is lower than the limit value of 0.05. Therefore torsion is considered as insignificant and is ignored in the combined checks.

**Combined bending, axial force and shear force check**

According to EN 1993-1-1 article 6.2.9.2 and formula (6.42)

Normal stresses		
<i>*Student version* *Student version* *Student version*</i>		
Fibre	12	
Sigma,N,Ed	37.1	MPa
Sigma,My,Ed	63.6	MPa
Sigma,Mz,Ed	151.2	MPa
Sigma,tot,Ed	251.9	MPa
Unity check	0.92	-

The member satisfies the section check.

**...:STABILITY CHECK:...:**

**Classification for member buckling design**

Decisive position for stability classification: 0.000 m

**Classification of Internal Compression parts**

According to EN 1993-1-1 Table 5.2 Sheet 1

Maximum width-to-thickness ratio	37.00
Class 1 Limit	30.51
Class 2 Limit	35.13
Class 3 Limit	48.52

=> Section classified as Class 3 for member buckling design

**Flexural Buckling check**

According to EN 1993-1-1 article 6.3.1.1 and formula (6.46)

Buckling parameters	yy	zz	
<i>*Student version* *Student version* *Student version* *Student version* *Student version* *St</i>			
Sway type	sway	non-sway	
System length L	4.750	4.750	m
Buckling factor k	1.07	0.57	
Buckling length Lcr	5.073	2.714	m
Critical Euler load Ncr	30771.78	107549.12	kN
Slenderness Lambda	32.10	17.17	
Relative slenderness Lambda,rel	0.37	0.20	
Limit slenderness Lambda,rel,0	0.20	0.20	

**Bending and axial compression check**

According to EN 1993-1-1 article 6.3.3 and formula (6.61),(6.62)

<b>Bending and axial compression check parameters</b>		
<i>*Student version* *Student version* *Student version* *Student version* *Student version* *Student version* *Student v</i>		
Interaction method	alternative method 1	
Cross-section area A	1.5300e-02	m <sup>2</sup>
Cross-section elastic modulus Wel,y	1.9110e-03	m <sup>3</sup>
Cross-section elastic modulus Wel,z	1.9110e-03	m <sup>3</sup>
Design compression force N,Ed	567.95	kN
Design bending moment (maximum) My,Ed	-134.58	kNm
Design bending moment (maximum) Mz,Ed	-299.89	kNm
Characteristic compression resistance N,Rk	4207.50	kN
Characteristic moment resistance My,Rk	525.52	kNm
Characteristic moment resistance Mz,Rk	525.52	kNm
Reduction factor Chi,y	1.00	
Reduction factor Chi,z	1.00	
Reduction factor Chi,LT	1.00	
Interaction factor k,yy	1.00	
Interaction factor k,yz	0.64	
Interaction factor k,zy	1.00	
Interaction factor k,zz	0.64	

Maximum moment My,Ed is derived from beam B28 position 0.000 m.

Maximum moment Mz,Ed is derived from beam B28 position 4.750 m.

<b>Interaction method 1 parameters</b>		
<i>*Student version* *Student version* *Student version* *Student version* *Student version* *Student version* *Student</i>		
Critical Euler load N,cr,y	30771.78	kN
Critical Euler load N,cr,z	107549.12	kN
Elastic critical load N,cr,T	992753.16	kN
Cross-section elastic modulus Wel,y	1.9110e-03	m <sup>3</sup>
Second moment of area Iy	3.8216e-04	m <sup>4</sup>
Second moment of area Iz	3.8216e-04	m <sup>4</sup>
Torsional constant It	6.0431e-04	m <sup>4</sup>
Method for equivalent moment factor C,my,0	Table A.2 Line 2 (General)	
Design bending moment (maximum) My,Ed	-134.58	kNm
Maximum relative deflection delta,z	0.6	mm
Equivalent moment factor C,my,0	0.98	
Method for equivalent moment factor C,mz,0	Table A.2 Line 1 (Linear)	
Ratio of end moments Psi,z	-0.72	
Equivalent moment factor C,mz,0	0.64	
Factor mu,y	1.00	
Factor mu,z	1.00	
Factor epsilon,y	1.90	
Factor a,LT	0.00	
Critical moment for uniform bending Mcr,0	41725.45	kNm
Relative slenderness Lambda,rel,0	0.11	
Limit relative slenderness Lambda,rel,0,lim	0.32	
Equivalent moment factor C,my	0.98	
Equivalent moment factor C,mz	0.64	
Equivalent moment factor C,mLT	1.00	

Unity check (6.61) = 0.13 + 0.26 + 0.37 = 0.76 -

Unity check (6.62) = 0.13 + 0.26 + 0.37 = 0.76 -

The member satisfies the stability check.

### 4.3 Dimenzioniranje pojasnice krovnog nosača

Dimenzioniranje konstrukcijskih elemenata je provedena softverom Scia Engineer 2016 pomoću modula Steel.

Uzdužna sila u pojasnici krovnog nosača (N)

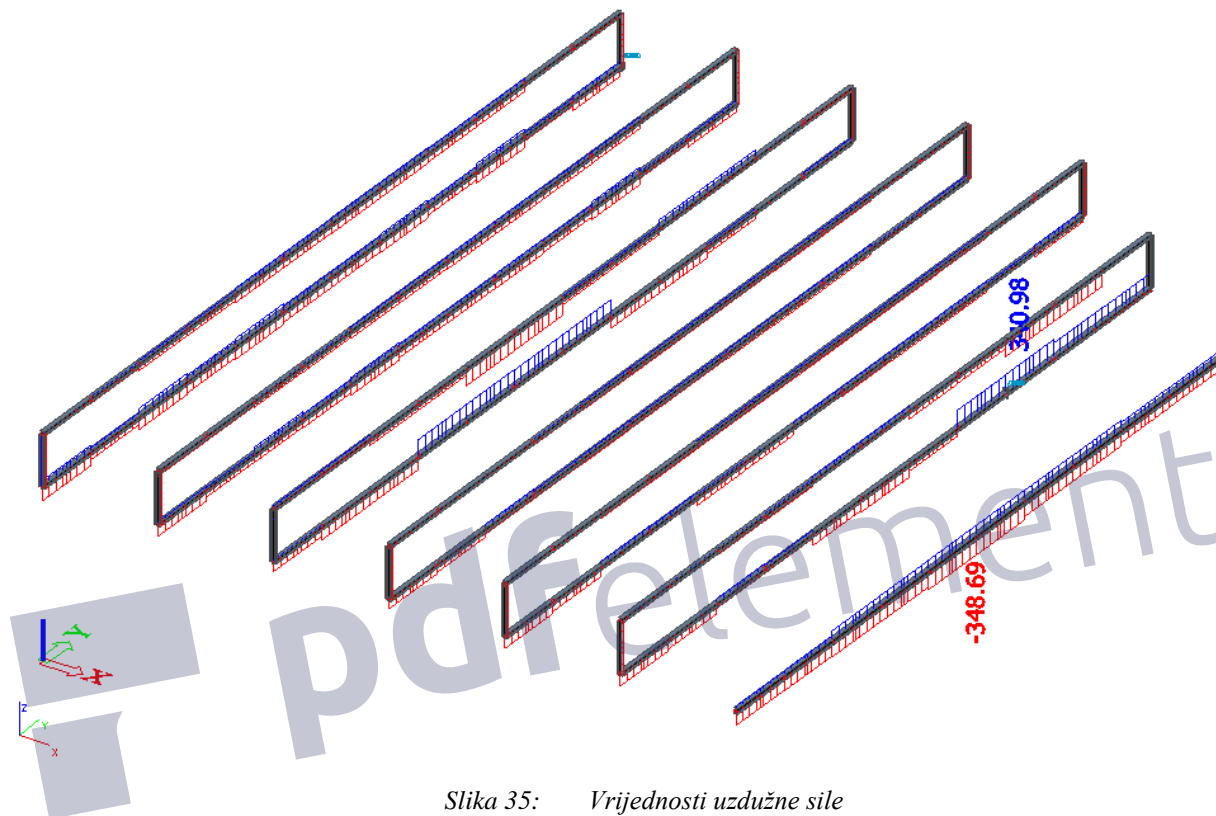

Slika 35: Vrijednosti uzdužne sile

Poprečna sila u pojasnici kovnog nosača(Vz)

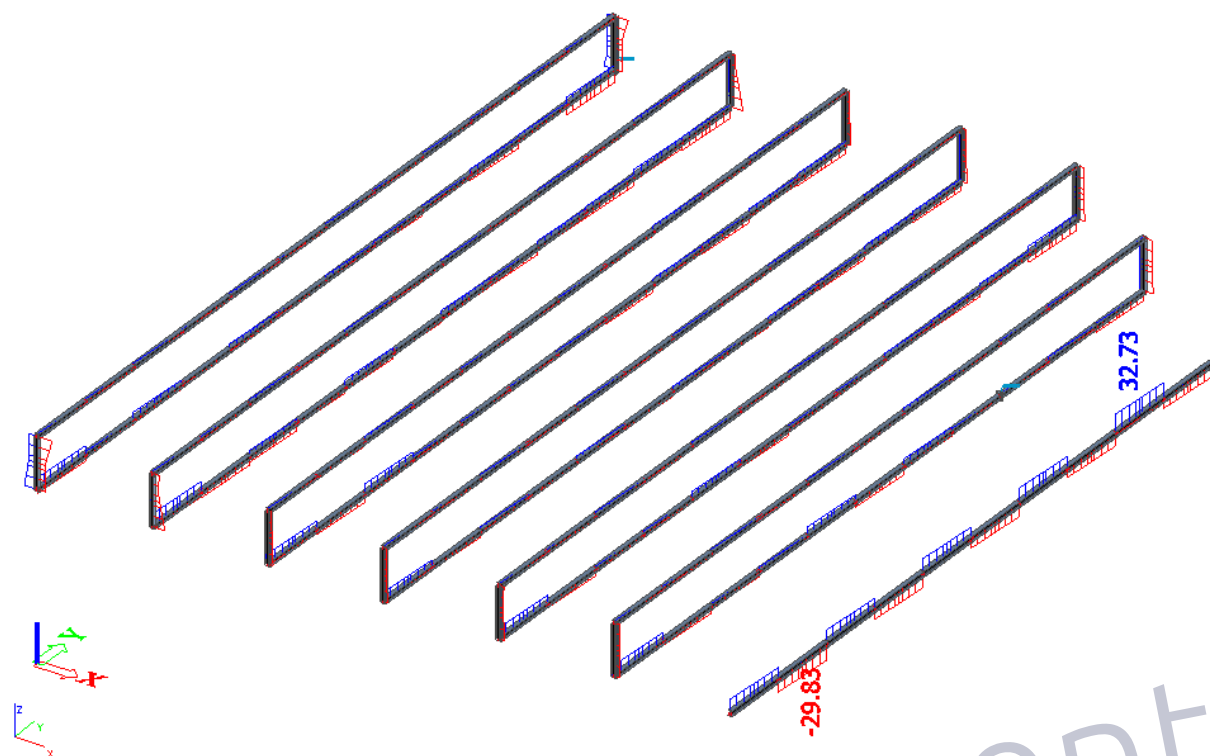

Slika 36: Vrijednosti poprečne sile

Moment savijanja u pojasnici krovnog nosača (My)

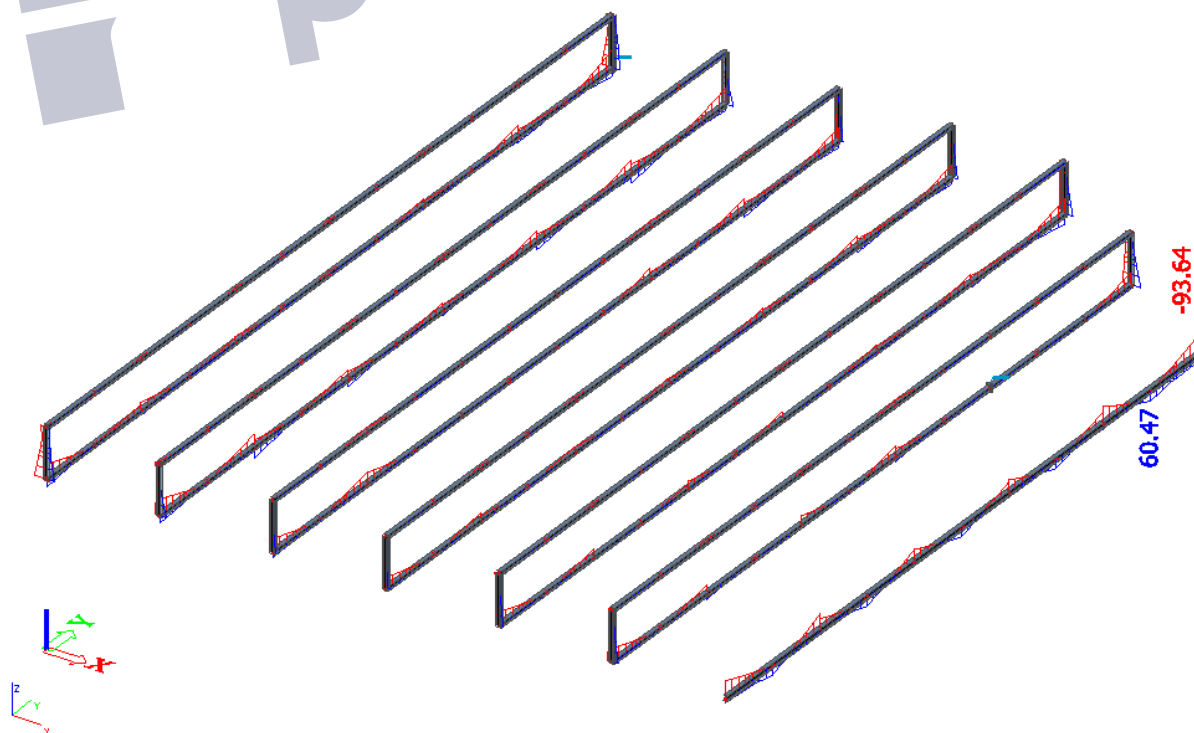

Slika 37: Vrijednosti momenta savijanja

Prikaz iskoristivosti elementa

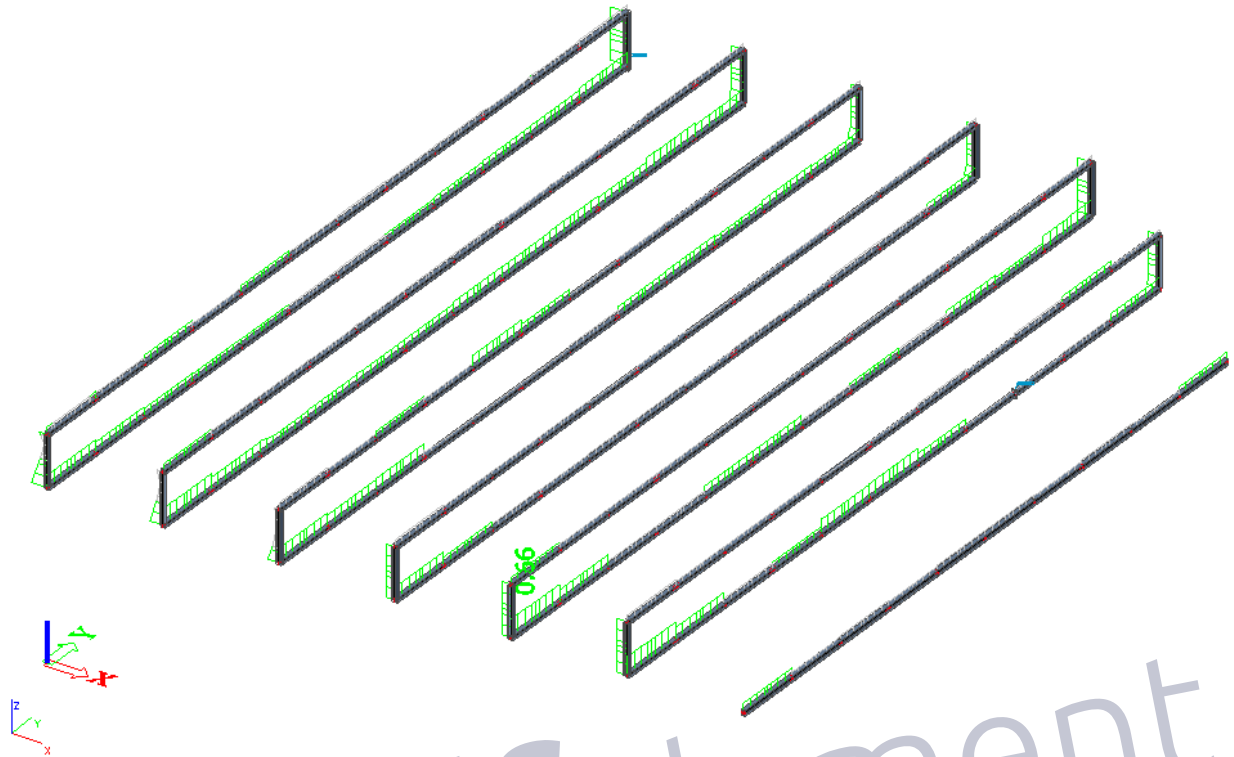

Slika 38: Vrijednosti iskoristivosti pojasa krovne rešetke

Poprečni presjek elementa

Name	CS16
Type	HEA320A
Source description	Profil Arbed / Structural shapes / Edition Octobre 1995
Item material	S 275
Fabrication	rolled
Flexural buckling y-y	b
Flexural buckling z-z	c
Lateral torsional buckling	Default
Use 2D FEM analysis	x

A [m <sup>2</sup> ]	9.4600e-03	
A <sub>y, z</sub> [m <sup>2</sup> ]	6.4733e-03	2.5878e-03
I <sub>y, z</sub> [m <sup>4</sup> ]	1.6500e-04	4.9600e-05
I <sub>w</sub> [m <sup>6</sup> ], t [m <sup>4</sup> ]	1.0407e-06	5.5900e-07
W <sub>el y, z</sub> [m <sup>3</sup> ]	1.0900e-03	3.3100e-04
W <sub>pl y, z</sub> [m <sup>3</sup> ]	1.1958e-03	5.0417e-04
d <sub>y, z</sub> [mm]	0	0
c <sub>YUCS, ZUCS</sub> [mm]	150	151
α [deg]	0.00	
A <sub>L, D</sub> [m <sup>2</sup> /m]	1.7400e+00	1.7394e+00
M <sub>ply +, -</sub> [Nm]	3.29e+05	3.29e+05
M <sub>plz +, -</sub> [Nm]	1.39e+05	1.39e+05

Dimenzioniranje elementa je provedeno u softveru (modul Steel)

<b>Member B17</b>	<b>10.000 m</b>	<b>HEA320A</b>	<b>S 275</b>	<b>GSN 11</b>	<b>0.66 -</b>
-------------------	-----------------	----------------	--------------	---------------	---------------

Partial safety factors	
<i>*Student version* *Student version* *Student version* *Student version*</i>	
Gamma M0 for resistance of cross-sections	1.00
Gamma M1 for resistance to instability	1.00
Gamma M2 for resistance of net sections	1.25

Material		
<i>*Student version* *Student version* *Student version*</i>		
Yield strength f <sub>y</sub>	275.0	MPa
Ultimate strength f <sub>u</sub>	430.0	MPa
Fabrication	Rolled	

...:SECTION CHECK:...

The critical check is on position 0.000 m

Internal forces	Calculated	Unit
<i>*Student version* *Student version* *Student version*</i>		
N,Ed	-226.18	kN
V <sub>y</sub> ,Ed	-4.79	kN
V <sub>z</sub> ,Ed	19.34	kN
T,Ed	0.02	kNm
M <sub>y</sub> ,Ed	-67.99	kNm
M <sub>z</sub> ,Ed	12.09	kNm

**Classification for cross-section design**

According to EN 1993-1-1 article 5.5.2

**Classification of Internal Compression parts**

According to EN 1993-1-1 Table 5.2 Sheet 1

Maximum width-to-thickness ratio	28.12
Class 1 Limit	43.22
Class 2 Limit	49.77
Class 3 Limit	68.77

=&gt; Internal Compression parts Class 1

**Classification of Outstand Flanges**

According to EN 1993-1-1 Table 5.2 Sheet 2

Maximum width-to-thickness ratio	10.82
Class 1 Limit	8.32
Class 2 Limit	9.24
Class 3 Limit	13.12

=&gt; Outstand Flanges Class 3

=&gt; Section classified as Class 3 for cross-section design

**Compression check**

According to EN 1993-1-1 article 6.2.4 and formula (6.9)

A	9.4600e-03	m <sup>2</sup>
N <sub>c,Rd</sub>	2601.50	kN
Unity check	0.09	-

**Bending moment check for M<sub>y</sub>**

According to EN 1993-1-1 article 6.2.5 and formula (6.12),(6.14)

W <sub>el,y,min</sub>	1.0900e-03	m <sup>3</sup>
M <sub>el,y,Rd</sub>	299.75	kNm
Unity check	0.23	-

**Bending moment check for M<sub>z</sub>**

According to EN 1993-1-1 article 6.2.5 and formula (6.12),(6.14)

W <sub>el,z,min</sub>	3.3100e-04	m <sup>3</sup>
M <sub>el,z,Rd</sub>	91.03	kNm
Unity check	0.13	-

**Shear check for V<sub>y</sub>**

According to EN 1993-1-1 article 6.2.6 and formula (6.17)

Eta	1.20	
A <sub>v</sub>	6.8800e-03	m <sup>2</sup>
V <sub>pl,y,Rd</sub>	1092.35	kN
Unity check	0.00	-

**Shear check for V<sub>z</sub>**

According to EN 1993-1-1 article 6.2.6 and formula (6.17)

Eta	1.20	
Av	3.5420e-03	m <sup>2</sup>
Vplz,Rd	562.37	kN
Unity check	0.03	-

**Torsion check**

According to EN 1993-1-1 article 6.2.7 and formula (6.23)

Tau,t,Ed	0.4	MPa
Tau,Rd	158.8	MPa
Unity check	0.00	-

**Combined bending, axial force and shear force check**

According to EN 1993-1-1 article 6.2.9.2 and formula (6.42)

Normal stresses		
<i>*Student version* *Student version* *Student version*</i>		
Fibre	3	
Sigma,N,Ed	23.9	MPa
Sigma,My,Ed	62.0	MPa
Sigma,Mz,Ed	36.6	MPa
Sigma,tot,Ed	122.5	MPa
Unity check	0.45	-

The member satisfies the section check.

**...:STABILITY CHECK:...:****Classification for member buckling design**

Decisive position for stability classification: 0.000 m

**Classification of Internal Compression parts**

According to EN 1993-1-1 Table 5.2 Sheet 1

Maximum width-to-thickness ratio	28.12
Class 1 Limit	43.22
Class 2 Limit	49.77
Class 3 Limit	68.77

=&gt; Internal Compression parts Class 1

**Classification of Outstand Flanges**

According to EN 1993-1-1 Table 5.2 Sheet 2

Maximum width-to-thickness ratio	10.82
Class 1 Limit	8.32
Class 2 Limit	9.24
Class 3 Limit	13.12

=&gt; Outstand Flanges Class 3

=&gt; Section classified as Class 3 for member buckling design



**Flexural Buckling check**

According to EN 1993-1-1 article 6.3.1.1 and formula (6.46)

Buckling parameters	yy	zz	
<i>*Student version* *Student version* *Student version* *Student version* *Student version* *</i>			
Sway type	sway	non-sway	
System length L	5.000	10.000	m
Buckling factor k	1.00	1.00	
Buckling length Lcr	5.000	10.000	m
Critical Euler load Ncr	13679.27	1028.02	kN
Slenderness Lambda	37.86	138.10	
Relative slenderness Lambda,rel	0.44	1.59	
Limit slenderness Lambda,rel,0	0.20	0.20	
Buckling curve	b	c	
Imperfection Alpha	0.34	0.49	
Reduction factor Chi	0.91	0.29	
Buckling resistance Nb,Rd	2371.24	746.23	kN

Flexural Buckling verification		
<i>*Student version* *Student version* *Student version* *Student version* *Student version* *</i>		
Cross-section area A	9.4600e-03	m <sup>2</sup>
Buckling resistance Nb,Rd	746.23	kN
Unity check	0.30	-

**Torsional(-Flexural) Buckling check**

According to EN 1993-1-1 article 6.3.1.1 and formula (6.46)

**Note:** For this I-section the Torsional(-Flexural) buckling resistance is higher than the resistance for Flexural buckling. Therefore Torsional(-Flexural) buckling is not printed on the output.

**Lateral Torsional Buckling check**

According to EN 1993-1-1 article 6.3.2.1 & 6.3.2.2 and formula (6.54)

LTB parameters		
<i>*Student version* *Student version* *Student version* *Student version* *Student version* *</i>		
Method for LTB curve	General case	
Cross-section elastic modulus Wel,y	1.0900e-03	m <sup>3</sup>
Elastic critical moment Mcr	903.67	kNm
Relative slenderness Lambda,rel,LT	0.58	
Limit slenderness Lambda,rel,LT,0	0.20	
LTB curve	a	
Imperfection Alpha,LT	0.21	
Reduction factor Chi,LT	0.90	
Design buckling resistance Mb,Rd	269.44	kNm
Unity check	0.25	-

Mcr parameters		
<i>*Student version* *Student version* *Student version* *Student version* *Student version* *</i>		
LTB length L	10.000	m
Influence of load position	no influence	
Correction factor k	1.00	
Correction factor kw	1.00	
LTB moment factor C1	3.45	
LTB moment factor C2	1.15	
LTB moment factor C3	0.41	
Shear center distance d,z	0	mm
Distance of load application z,g	0	mm
Mono-symmetry constant beta,y	0	mm
Mono-symmetry constant z,j	0	mm

**Note:** C parameters are determined according to ECCS 119 2006 / Galea 2002.

### Bending and axial compression check

According to EN 1993-1-1 article 6.3.3 and fomula (6.61),(6.62)

Bending and axial compression check parameters		
<i>*Student version* *Student version* *Student version* *Student version* *Student version* *Student version* *Student v</i>		
Interaction method	alternative method 1	
Cross-section area A	9.4600e-03	m <sup>2</sup>
Cross-section elastic modulus Wel,y	1.0900e-03	m <sup>3</sup>
Cross-section elastic modulus Wel,z	3.3100e-04	m <sup>3</sup>
Design compression force N,Ed	226.18	kN
Design bending moment (maximum) My,Ed	-67.99	kNm
Design bending moment (maximum) Mz,Ed	12.09	kNm
Characteristic compression resistance N,Rk	2601.50	kN
Characteristic moment resistance My,Rk	299.75	kNm
Characteristic moment resistance Mz,Rk	91.03	kNm
Reduction factor Chi,y	0.91	
Reduction factor Chi,z	0.29	
Reduction factor Chi,LT	0.90	
Interaction factor k,yy	1.18	
Interaction factor k,yz	1.02	
Interaction factor k,zy	0.98	
Interaction factor k,zz	0.85	

Maximum moment My,Ed is derived from beam B17 position 0.000 m.

Maximum moment Mz,Ed is derived from beam B17 position 0.000 m.

Interaction method 1 parameters		
<i>*Student version* *Student version* *Student version* *Student version* *Student version* *Student version* *Studer</i>		
Critical Euler load N,cr,y	13679.27	kN
Critical Euler load N,cr,z	1028.02	kN
Elastic critical load N,cr,T	2941.17	kN
Cross-section elastic modulus Wel,y	1.0900e-03	m <sup>3</sup>
Second moment of area Iy	1.6500e-04	m <sup>4</sup>
Second moment of area Iz	4.9600e-05	m <sup>4</sup>
Torsional constant It	5.5900e-07	m <sup>4</sup>
Method for equivalent moment factor C,my,0	Table A.2 Line 2 (General)	
Design bending moment (maximum) My,Ed	-67.99	kNm
Maximum relative deflection delta,z	2.2	mm
Equivalent moment factor C,my,0	0.99	
Method for equivalent moment factor C,mz,0	Table A.2 Line 2 (General)	
Design bending moment (maximum) Mz,Ed	12.09	kNm
Maximum relative deflection delta,y	1.0	mm
Equivalent moment factor C,mz,0	0.80	
Factor mu,y	1.00	
Factor mu,z	0.83	
Factor epsilon,y	2.61	
Factor a,LT	1.00	
Critical moment for uniform bending Mcr,0	261.90	kNm
Relative slenderness Lambda,rel,0	1.07	
Limit relative slendemess Lambda,rel,0,lim	0.34	
Equivalent moment factor C,my	1.00	
Equivalent moment factor C,mz	0.80	
Equivalent moment factor C,mLT	1.17	

Unity check (6.61) =  $0.10 + 0.30 + 0.14 = 0.53$  -

Unity check (6.62) =  $0.30 + 0.25 + 0.11 = 0.66$  -

### Shear Buckling check

According to EN 1993-1-5 article 5 & 7.1 and formula (5.10) & (7.1)

Shear Buckling parameters		
Buckling field length a	10.000	m
Web	unstiffened	
Web height hw	279	mm
Web thickness t	8	mm
Material coefficient epsilon	0.92	
Shear correction factor Eta	1.20	

Shear Buckling verification	
Web slenderness hw/t	34.87
Web slenderness limit	55.46

**Note:** The web slenderness is such that Shear Buckling effects may be ignored according to EN 1993-1-5 article 5.1(2).

The member satisfies the stability check.

pdfelement

## 4.4 Dimenzioniranje vertikalne ispune krovnog nosača

Dimenzioniranje konstrukcijskih elemenata je provedena softverom Scia Engineer 2016 pomoću modula Steel.

Uzdužna sila u vertikalnoj ispuni krovnog nosača (N)

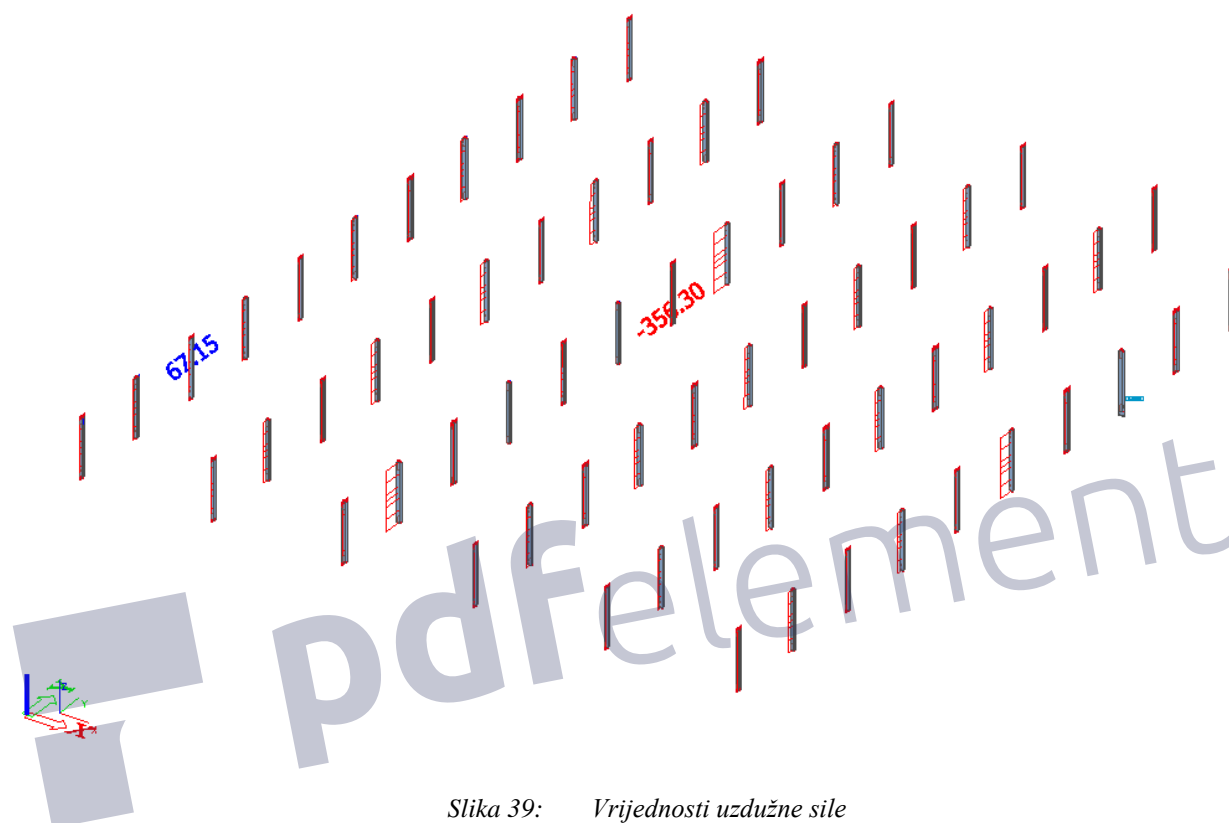

Slika 39: Vrijednosti uzdužne sile

Poprečna sila u vertikalnoj ispuni krovnog nosača ( $V_y$ )

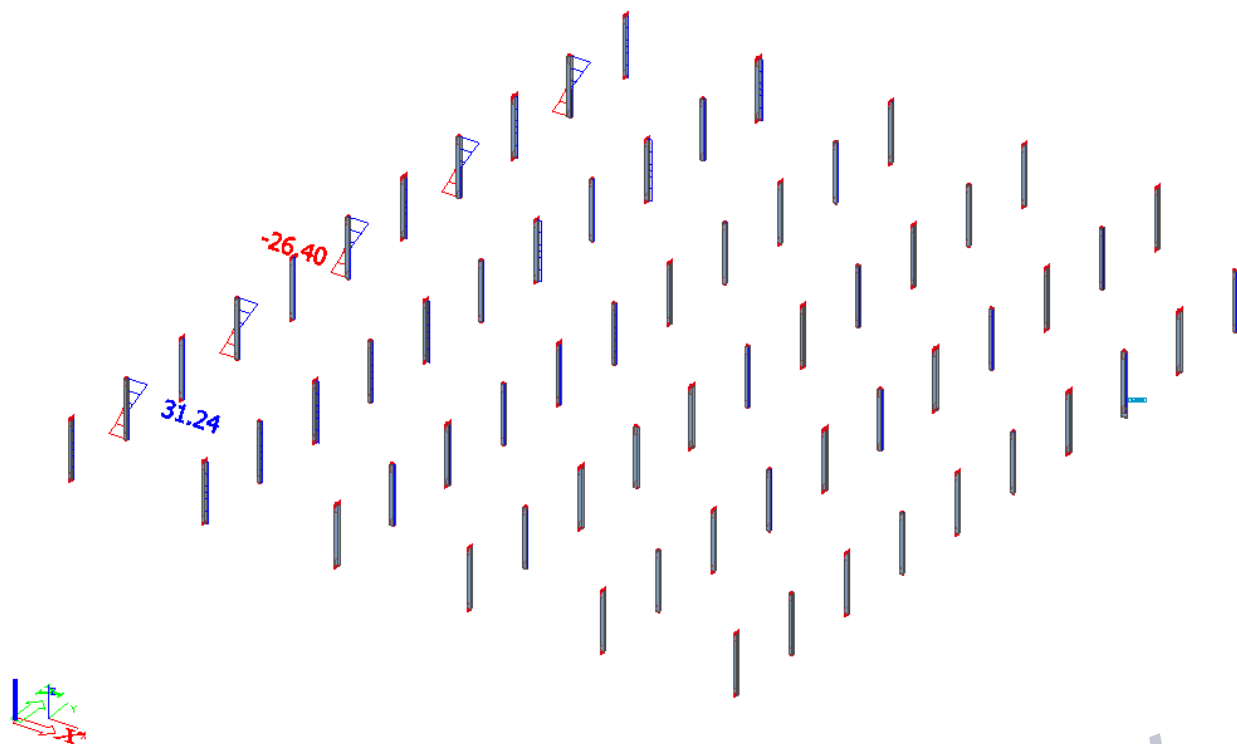

Slika 40: Vrijednosti poprečne sile

Moment savijanja u vertikalnoj ispuni krovnog nosača (Mz)

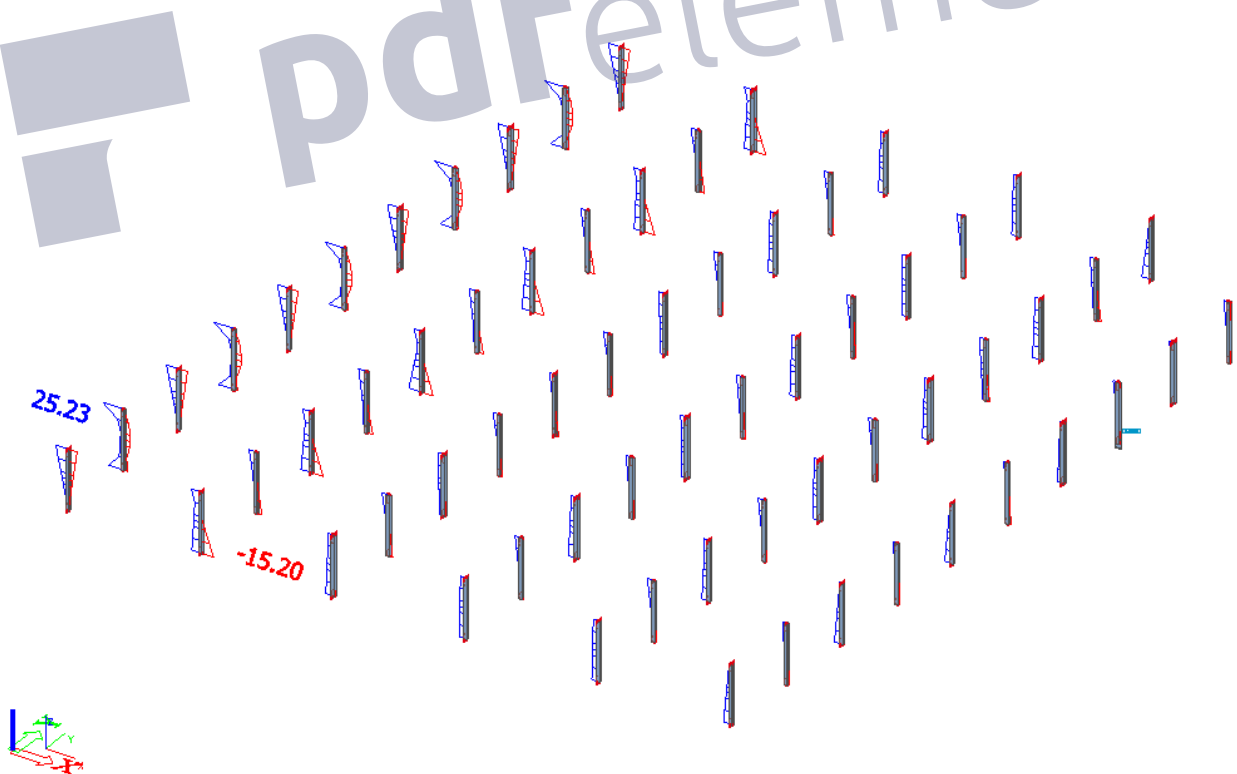

Slika 41: Vrijednosti momenta savijanja

Prikaz iskoristivosti elementa

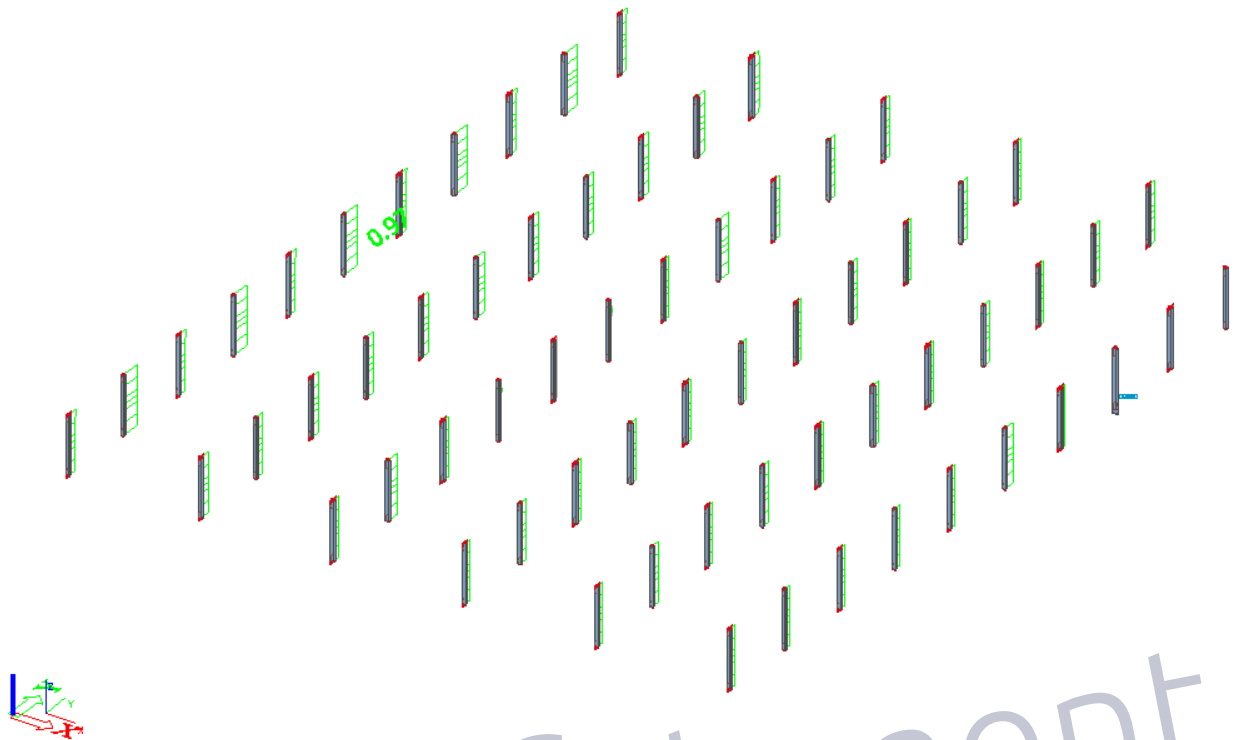

Slika 42: Prikaz iskoristivosti elementa

Poprečni presjek elementa

Name	CS28
Type	HEA200A
Source description	Profil Arbed / Structural shapes / Edition Octobre 1995
Item material	S 275
Fabrication	rolled
Flexural buckling y-y	b
Flexural buckling z-z	c
Lateral torsional buckling	Default
Use 2D FEM analysis	x

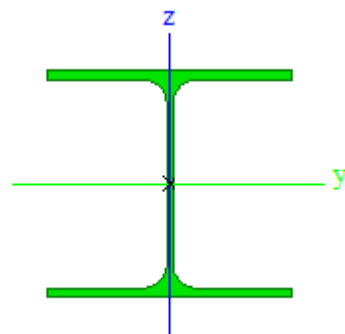

A [m <sup>2</sup> ]	4.4100e-03	
A <sub>y, z</sub> [m <sup>2</sup> ]	3.1221e-03	1.1054e-03
I <sub>y, z</sub> [m <sup>4</sup> ]	2.9400e-05	1.0700e-05
I <sub>w</sub> [m <sup>6</sup> ], t [m <sup>4</sup> ]	8.4491e-08	1.2700e-07
W <sub>el y, z</sub> [m <sup>3</sup> ]	3.1700e-04	1.0700e-04
W <sub>pl y, z</sub> [m <sup>3</sup> ]	3.4708e-04	1.6333e-04
d <sub>y, z</sub> [mm]	0	0
c <sub>YUCS, ZUCS</sub> [mm]	100	93
α [deg]	0.00	
A <sub>L, D</sub> [m <sup>2</sup> /m]	1.1300e+00	1.1300e+00
M <sub>ply +, -</sub> [Nm]	9.56e+04	9.56e+04
M <sub>plz +, -</sub> [Nm]	4.49e+04	4.49e+04

Dimenzioniranje elementa je provedeno u softveru (modul Steel)

<b>Member B103</b>	<b>3.500 m</b>	<b>HEA200A</b>	<b>S 275</b>	<b>GSN 4</b>	<b>0.97 -</b>
--------------------	----------------	----------------	--------------	--------------	---------------

Partial safety factors	
<i>*Student version* *Student version* *Student version* *Student version*</i>	
Gamma M0 for resistance of cross-sections	1.00
Gamma M1 for resistance to instability	1.00
Gamma M2 for resistance of net sections	1.25

Material		
<i>*Student version* *Student version* *Student version*</i>		
Yield strength f <sub>y</sub>	275.0	MPa
Ultimate strength f <sub>u</sub>	430.0	MPa
Fabrication	Rolled	

...:SECTION CHECK:...:

The critical check is on position 0.000 m

Internal forces	Calculated	Unit
<i>*Student version* *Student version* *Student version*</i>		
N,Ed	-117.69	kN
V <sub>y</sub> ,Ed	-23.45	kN
V <sub>z</sub> ,Ed	0.00	kN
T,Ed	0.00	kNm
M <sub>y</sub> ,Ed	0.00	kNm
M <sub>z</sub> ,Ed	12.23	kNm

**Classification for cross-section design**

According to EN 1993-1-1 article 5.5.2

**Classification of Internal Compression parts**

According to EN 1993-1-1 Table 5.2 Sheet 1

Maximum width-to-thickness ratio	24.36
Class 1 Limit	30.51
Class 2 Limit	35.13
Class 3 Limit	38.83

=&gt; Internal Compression parts Class 1

**Classification of Outstand Flanges**

According to EN 1993-1-1 Table 5.2 Sheet 2

Maximum width-to-thickness ratio	9.91
Class 1 Limit	8.32
Class 2 Limit	9.24
Class 3 Limit	14.08

=&gt; Outstand Flanges Class 3

=&gt; Section classified as Class 3 for cross-section design

**Compression check**

According to EN 1993-1-1 article 6.2.4 and formula (6.9)

A	4.4100e-03	m <sup>2</sup>
Nc,Rd	1212.75	kN
Unity check	0.10	-

**Bending moment check for Mz**

According to EN 1993-1-1 article 6.2.5 and formula (6.12), (6.14)

W <sub>el,z</sub> min	1.0700e-04	m <sup>3</sup>
M <sub>el,z</sub> Rd	29.43	kNm
Unity check	0.42	-

**Shear check for V<sub>y</sub>**

According to EN 1993-1-1 article 6.2.6 and formula (6.17)

Eta	1.20	
A <sub>v</sub>	3.3293e-03	m <sup>2</sup>
V <sub>pl,y</sub> Rd	528.59	kN
Unity check	0.04	-

**Torsion check**

According to EN 1993-1-1 article 6.2.7 and formula (6.23)

Tau,tEd	0.0	MPa
Tau,Rd	158.8	MPa
Unity check	0.00	-

**Note:** The unity check for torsion is lower than the limit value of 0.05. Therefore torsion is considered as insignificant and is ignored in the combined checks.

**Combined bending, axial force and shear force check**

According to EN 1993-1-1 article 6.2.9.2 and formula (6.42)



Normal stresses		
<i>*Student version*</i> <i>*Student version*</i> <i>*Student version*</i>		
Fibre	3	
Sigma,N,Ed	26.7	MPa
Sigma,My,Ed	0.0	MPa
Sigma,Mz,Ed	114.3	MPa
Sigma,tot,Ed	141.0	MPa
Unity check	0.51	-

The member satisfies the section check.

### ...:STABILITY CHECK:...:

#### Classification for member buckling design

Decisive position for stability classification: 0.000 m

#### Classification of Internal Compression parts

According to EN 1993-1-1 Table 5.2 Sheet 1

Maximum width-to-thickness ratio	24.36
Class 1 Limit	30.51
Class 2 Limit	35.13
Class 3 Limit	38.83

=> Internal Compression parts Class 1

#### Classification of Outstand Flanges

According to EN 1993-1-1 Table 5.2 Sheet 2

Maximum width-to-thickness ratio	9.91
Class 1 Limit	8.32
Class 2 Limit	9.24
Class 3 Limit	14.08

=> Outstand Flanges Class 3

=> Section classified as Class 3 for member buckling design

#### Flexural Buckling check

According to EN 1993-1-1 article 6.3.1.1 and formula (6.46)

Buckling parameters	yy	zz	
<i>*Student version*</i> <i>*Student version*</i> <i>*Student version*</i> <i>*Student version*</i> <i>*Student version*</i>			
Sway type	sway	non-sway	
System length L	3.500	3.500	m
Buckling factor k	1.00	0.76	
Buckling length Lcr	3.500	2.661	m
Critical Euler load Ncr	4974.28	3130.89	kN
Slenderness Lambda	42.87	54.03	
Relative slenderness Lambda,rel	0.49	0.62	
Limit slenderness Lambda,rel,0	0.20	0.20	

**Note:** The slenderness or compression force is such that Flexural Buckling effects may be ignored according to EN 1993-1-1 article 6.3.1.2(4).

#### Torsional(-Flexural) Buckling check

According to EN 1993-1-1 article 6.3.1.1 and formula (6.46)

Torsional buckling length $L_{cr}$	3.500	m
Elastic critical load $N_{cr,T}$	2700.21	kN
Elastic critical load $N_{cr,TF}$	2700.21	kN
Relative slenderness $\lambda_{rel,T}$	0.67	
Limit slenderness $\lambda_{rel,0}$	0.20	
Buckling curve	c	
Imperfection $\alpha$	0.49	
Reduction factor $\chi$	0.74	
Cross-section area $A$	4.4100e-03	m <sup>2</sup>
Buckling resistance $N_{b,Rd}$	901.15	kN
Unity check	0.13	-

### Bending and axial compression check

According to EN 1993-1-1 article 6.3.3 and formula (6.61),(6.62)

Bending and axial compression check parameters		
<i>*Student version* *Student version* *Student version* *Student version* *Student version* *Student version* *Student v</i>		
Interaction method	alternative method 1	
Cross-section area $A$	4.4100e-03	m <sup>2</sup>
Cross-section elastic modulus $W_{el,z}$	1.0700e-04	m <sup>3</sup>
Design compression force $N_{Ed}$	117.69	kN
Design bending moment (maximum) $M_{y,Ed}$	0.00	kNm
Design bending moment (maximum) $M_{z,Ed}$	24.53	kNm
Characteristic compression resistance $N_{Rk}$	1212.75	kN
Characteristic moment resistance $M_{z,Rk}$	29.43	kNm
Reduction factor $\chi_{y,z}$	1.00	
Reduction factor $\chi_{i,z}$	0.74	
Reduction factor $\chi_{i,LT}$	1.00	
Interaction factor $k_{y,z}$	1.00	
Interaction factor $k_{z,z}$	1.00	

Maximum moment  $M_{y,Ed}$  is derived from beam B103 position 0.000 m.  
Maximum moment  $M_{z,Ed}$  is derived from beam B103 position 3.500 m.

Interaction method 1 parameters		
<i>*Student version* *Student version* *Student version* *Student version* *Student version* *Student version* *Student</i>		
Critical Euler load $N_{cr,y}$	4974.28	kN
Critical Euler load $N_{cr,z}$	3130.89	kN
Elastic critical load $N_{cr,T}$	2700.21	kN
Second moment of area $I_y$	2.9400e-05	m <sup>4</sup>
Second moment of area $I_z$	1.0700e-05	m <sup>4</sup>
Torsional constant $I_t$	1.2700e-07	m <sup>4</sup>
Method for equivalent moment factor $C_{mz,0}$	Table A.2 Line 2 (General)	
Design bending moment (maximum) $M_{z,Ed}$	24.53	kNm
Maximum relative deflection $\delta_{rel,y}$	1.1	mm
Equivalent moment factor $C_{mz,0}$	0.97	
Factor $\mu_{y,z}$	1.00	
Factor $\mu_{z,z}$	1.00	
Factor $a_{LT}$	1.00	
Critical moment for uniform bending $M_{cr,0}$	210.83	kNm
Relative slenderness $\lambda_{rel,0}$	0.64	
Equivalent moment factor $C_{mz}$	0.97	

Unity check (6.61) = 0.10 + 0.00 + 0.84 = 0.93 -

Unity check (6.62) = 0.13 + 0.00 + 0.84 = 0.97 -

The member satisfies the stability check.

#### 4.5 Dimenzioniranje kose grede krovne konstrukcije

Dimenzioniranje konstrukcijskih elemenata je provedena softverom Scia Engineer 2016 pomoću modula Steel.

Uzdužna sila u kosoj gredi (N)

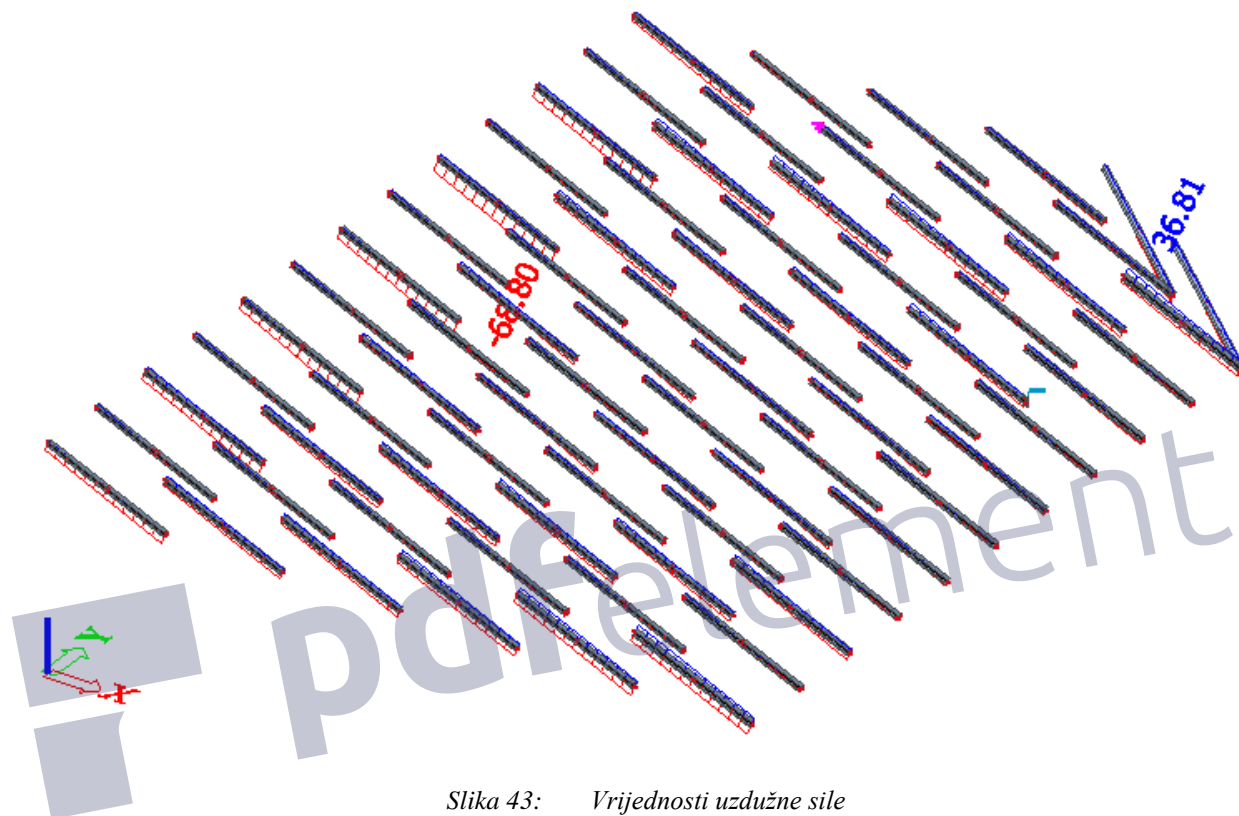

Slika 43: Vrijednosti uzdužne sile

Poprečna sila u kosoj gredi ( $V_y$ )

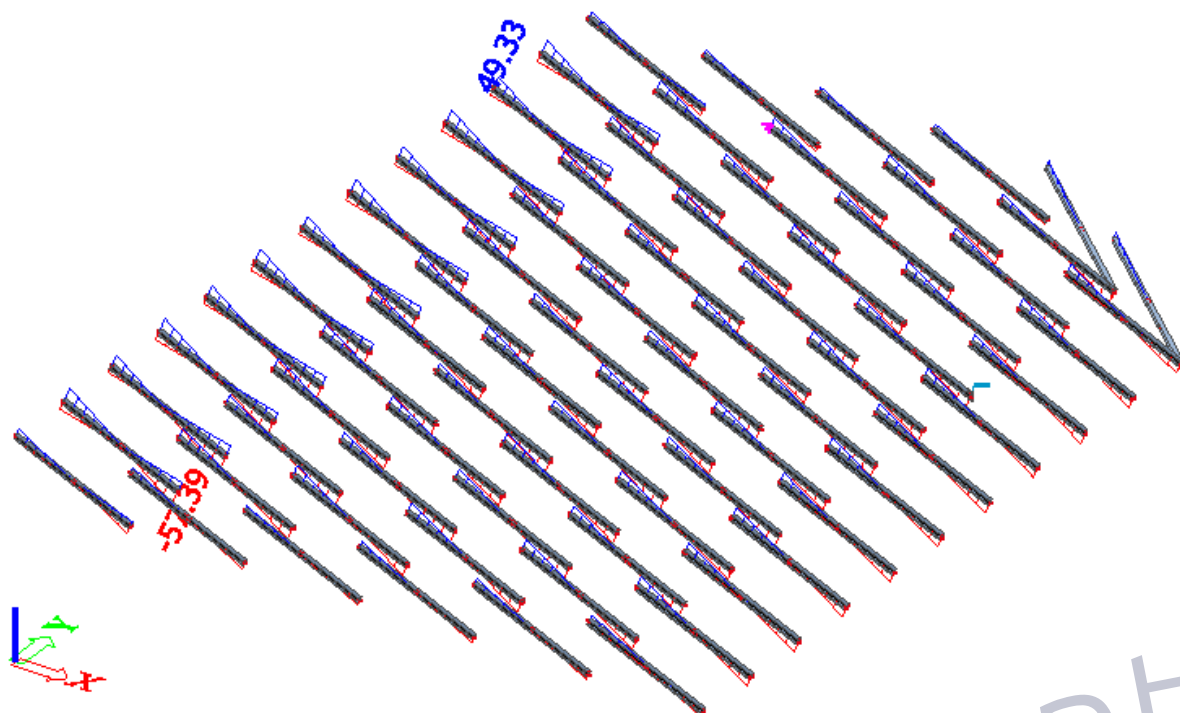

Slika 44: Vrijednosti poprečne sile

Moment savijanja u kosoj gredi ( $M_y$ )

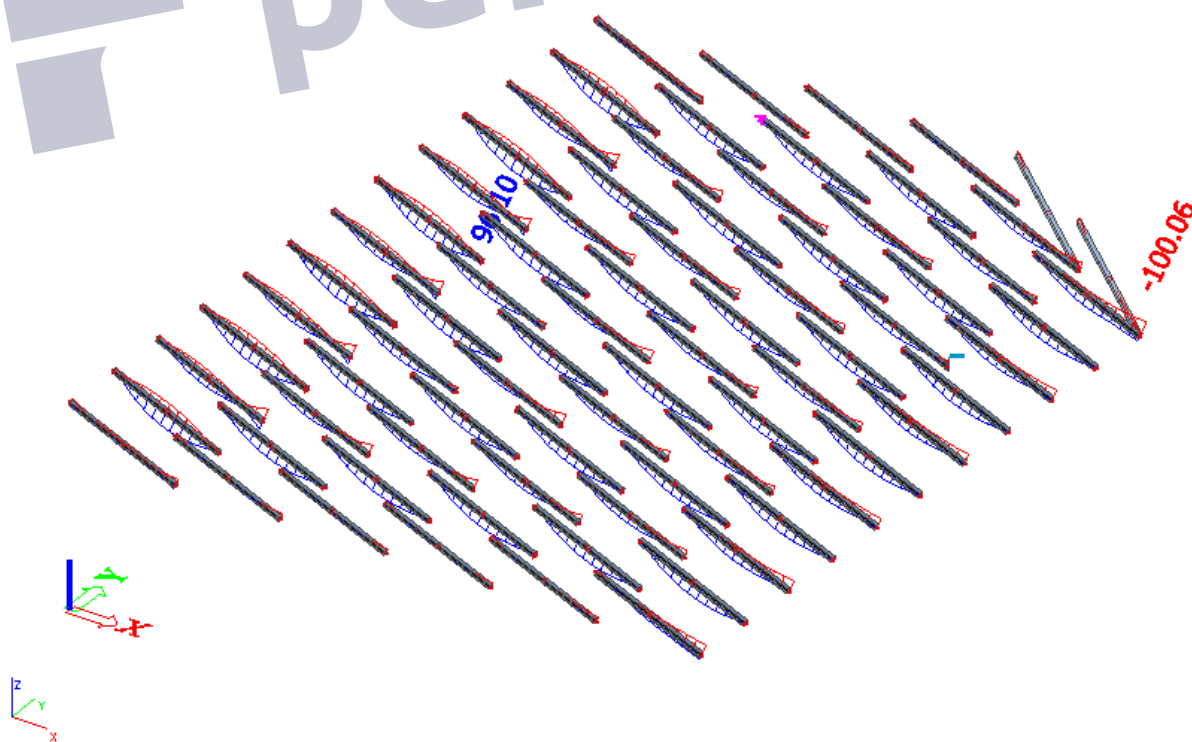

Slika 45: Vrijednosti momenta savijanja

Prikaz iskoristivosti elementa

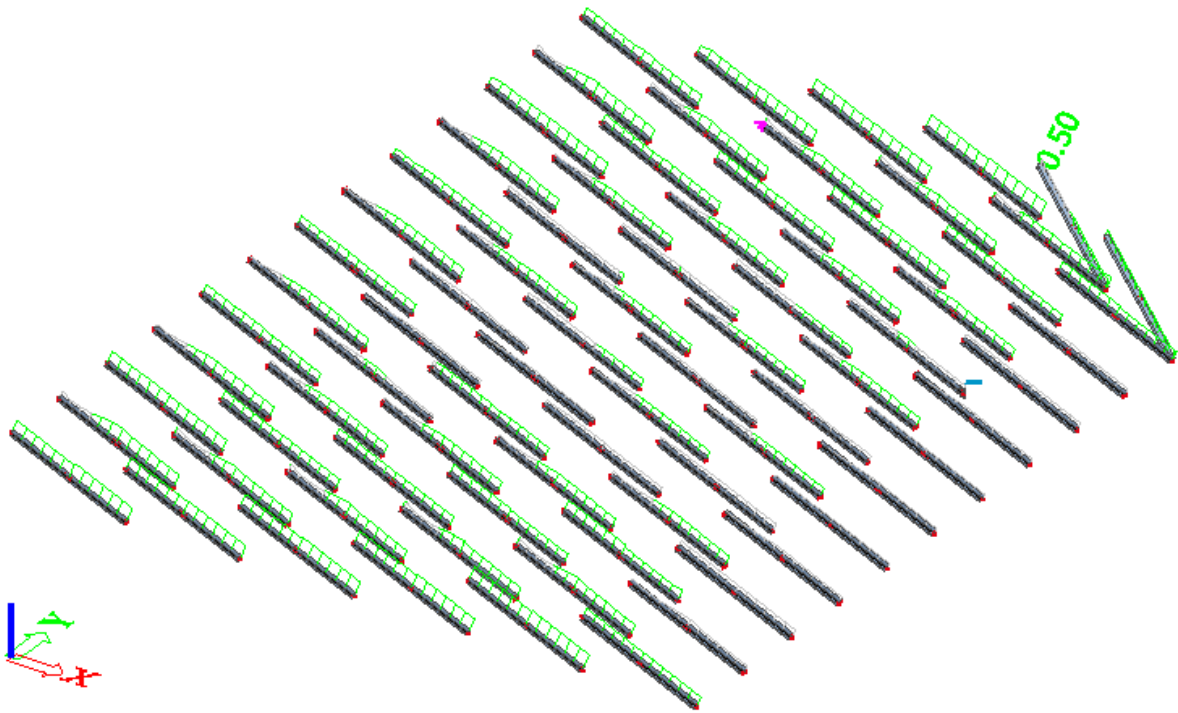

Slika 46: Prikaz iskoristivosti elementa

Poprečni presjek elementa

Name	CS16
Type	HEA320A
Source description	Profil Arbed / Structural shapes / Edition Octobre 1995
Item material	S 275
Fabrication	rolled
Flexural buckling y-y	b
Flexural buckling z-z	c
Lateral torsional buckling	Default
Use 2D FEM analysis	x

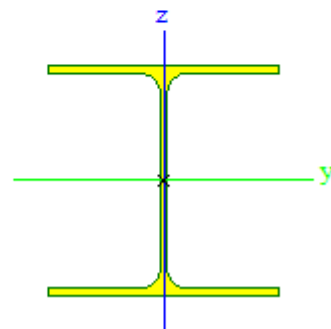

A [m <sup>2</sup> ]	9.4600e-03	
A <sub>y, z</sub> [m <sup>2</sup> ]	6.4733e-03	2.5878e-03
I <sub>y, z</sub> [m <sup>4</sup> ]	1.6500e-04	4.9600e-05
I <sub>w</sub> [m <sup>6</sup> ], t [m <sup>4</sup> ]	1.0407e-06	5.5900e-07
W <sub>ely, z</sub> [m <sup>3</sup> ]	1.0900e-03	3.3100e-04
W <sub>ply, z</sub> [m <sup>3</sup> ]	1.1958e-03	5.0417e-04
d <sub>y, z</sub> [mm]	0	0
c <sub>YUCS, ZUCS</sub> [mm]	150	151
α [deg]	0.00	
A <sub>L, D</sub> [m <sup>2</sup> /m]	1.7400e+00	1.7394e+00
M <sub>ply +, -</sub> [Nm]	3.29e+05	3.29e+05
M <sub>plz +, -</sub> [Nm]	1.39e+05	1.39e+05

Dimenzioniranje elementa je provedeno u softveru (modul Steel)

<b>Member B353</b>	<b>10.062 m</b>	<b>HEA320A</b>	<b>S 275</b>	<b>GSN 11</b>	<b>0.32 -</b>
<b>Partial safety factors</b>					
<i>*Student version* *Student version* *Student version* *Student version* *</i>					
Gamma M0 for resistance of cross-sections	1.00				
Gamma M1 for resistance to instability	1.00				
Gamma M2 for resistance of net sections	1.25				

<b>Material</b>		
<i>*Student version* *Student version* *Student version* *</i>		
Yield strength f <sub>y</sub>	275.0	MPa
Ultimate strength f <sub>u</sub>	430.0	MPa
Fabrication	Rolled	

...::SECTION CHECK:...:

The critical check is on position 5.031 m

<b>Internal forces</b>	<b>Calculated</b>	<b>Unit</b>
<i>*Student version* *Student version* *Student version* *</i>		
N <sub>,Ed</sub>	-31.82	kN
V <sub>y,Ed</sub>	-10.31	kN
V <sub>z,Ed</sub>	2.17	kN
T <sub>,Ed</sub>	-0.03	kNm
M <sub>y,Ed</sub>	3.83	kNm
M <sub>z,Ed</sub>	26.86	kNm

**Classification for cross-section design**

According to EN 1993-1-1 article 5.5.2

**Classification of Internal Compression parts**

According to EN 1993-1-1 Table 5.2 Sheet 1

Maximum width-to-thickness ratio	28.12
Class 1 Limit	30.51
Class 2 Limit	35.13
Class 3 Limit	54.58

=&gt; Internal Compression parts Class 1

**Classification of Outstand Flanges**

According to EN 1993-1-1 Table 5.2 Sheet 2

Maximum width-to-thickness ratio	10.82
Class 1 Limit	8.32
Class 2 Limit	9.24
Class 3 Limit	14.63

=&gt; Outstand Flanges Class 3

=&gt; Section classified as Class 3 for cross-section design

**Compression check**

According to EN 1993-1-1 article 6.2.4 and fomula (6.9)

A	9.4600e-03	m <sup>2</sup>
Nc,Rd	2601.50	kN
Unity check	0.01	-

**Bending moment check for My**

According to EN 1993-1-1 article 6.2.5 and fomula (6.12),(6.14)

W <sub>el,y,min</sub>	1.0900e-03	m <sup>3</sup>
M <sub>el,y,Rd</sub>	299.75	kNm
Unity check	0.01	-

**Bending moment check for Mz**

According to EN 1993-1-1 article 6.2.5 and fomula (6.12),(6.14)

W <sub>el,z,min</sub>	3.3100e-04	m <sup>3</sup>
M <sub>el,z,Rd</sub>	91.03	kNm
Unity check	0.30	-

**Shear check for Vy**

According to EN 1993-1-1 article 6.2.6 and fomula (6.17)

Eta	1.20	
A <sub>v</sub>	6.8800e-03	m <sup>2</sup>
V <sub>pl,y,Rd</sub>	1092.35	kN
Unity check	0.01	-

**Shear check for Vz**

According to EN 1993-1-1 article 6.2.6 and fomula (6.17)

Eta	1.20	
A <sub>v</sub>	3.5420e-03	m <sup>2</sup>
V <sub>pl,z,Rd</sub>	562.37	kN
Unity check	0.00	-

Eta	1.20	
Av	3.5420e-03	m <sup>2</sup>
Vpl,z,Rd	562.37	kN
Unity check	0.00	-

**Torsion check**

According to EN 1993-1-1 article 6.2.7 and formula (6.23)

Tau,t,Ed	0.6	MPa
Tau,Rd	158.8	MPa
Unity check	0.00	-

**Note:** The unity check for torsion is lower than the limit value of 0.05. Therefore torsion is considered as insignificant and is ignored in the combined checks.

**Combined bending, axial force and shear force check**

According to EN 1993-1-1 article 6.2.9.2 and formula (6.42)

Normal stresses		
<i>*Student version* *Student version* *Student versi</i>		
Fibre	13	
Sigma,N,Ed	3.4	MPa
Sigma,My,Ed	3.5	MPa
Sigma,Mz,Ed	81.2	MPa
Sigma,tot,Ed	88.1	MPa
Unity check	0.32	-

The member satisfies the section check.

**...:STABILITY CHECK:...****Classification for member buckling design**

Decisive position for stability classification: 0.000 m

**Classification of Internal Compression parts**

According to EN 1993-1-1 Table 5.2 Sheet 1

Maximum width-to-thickness ratio	28.12
Class 1 Limit	64.06
Class 2 Limit	73.76
Class 3 Limit	82.69

=> Internal Compression parts Class 1

**Classification of Outstand Flanges**

According to EN 1993-1-1 Table 5.2 Sheet 2

Maximum width-to-thickness ratio	10.82
Class 1 Limit	8.32
Class 2 Limit	9.24
Class 3 Limit	14.25

=> Outstand Flanges Class 3

=> Section classified as Class 3 for member buckling design

**Flexural Buckling check**

According to EN 1993-1-1 article 6.3.1.1 and formula (6.46)



Buckling parameters	yy	zz	
<i>*Student version* *Student version* *Student version* *Student version* *Student version*</i>			
Sway type	sway	non-sway	
System length L	10.062	5.031	m
Buckling factor k	1.00	1.00	
Buckling length Lcr	10.062	5.031	m
Critical Euler load Ncr	3377.60	4061.31	kN
Slenderness Lambda	76.19	69.48	
Relative slenderness Lambda,rel	0.88	0.80	
Limit slenderness Lambda,rel,0	0.20	0.20	

**Note:** The slenderness or compression force is such that Flexural Buckling effects may be ignored according to EN 1993-1-1 article 6.3.1.2(4).

**Torsional(-Flexural) Buckling check**

According to EN 1993-1-1 article 6.3.1.1 and formula (6.46)

**Note:** For this I-section the Torsional(-Flexural) buckling resistance is higher than the resistance for Flexural buckling. Therefore Torsional(-Flexural) buckling is not printed on the output.

**Lateral Torsional Buckling check**

According to EN 1993-1-1 article 6.3.2.1 & 6.3.2.2 and formula (6.54)

LTB parameters		
<i>*Student version* *Student version* *Student version* *Student version* *Student versic</i>		
Method for LTB curve	General case	
Cross-section elastic modulus $W_{el,y}$	1.0900e-03	m <sup>3</sup>
Elastic critical moment Mcr	1718.94	kNm
Relative slenderness Lambda,rel,LT	0.42	
Limit slenderness Lambda,rel,LT,0	0.20	

**Note:** The slenderness or bending moment is such that Lateral Torsional Buckling effects may be ignored according to EN 1993-1-1 article 6.3.2.2(4).

Mcr parameters		
<i>*Student version* *Student version* *Student version* *Student version* *Stud</i>		
LTB length L	5.031	m
Influence of load position	no influence	
Correction factor k	1.00	
Correction factor kw	1.00	
LTB moment factor C1	2.36	
LTB moment factor C2	0.60	
LTB moment factor C3	1.00	
Shear center distance d,z	0	mm
Distance of load application z,g	0	mm
Mono-symmetry constant beta,y	0	mm
Mono-symmetry constant z,j	0	mm

**Note:** C parameters are determined according to ECCS 119 2006 / Galea 2002.

**Bending and axial compression check**

According to EN 1993-1-1 article 6.3.3 and fomula (6.61),(6.62)

Bending and axial compression check parameters		
<i>*Student version* *Student version* *Student version* *Student version* *Student version* *Student version* *Student v</i>		
Interaction method	alternative method 1	
Cross-section area A	9.4600e-03	m <sup>2</sup>
Cross-section elastic modulus Wel,y	1.0900e-03	m <sup>3</sup>
Cross-section elastic modulus Wel,z	3.3100e-04	m <sup>3</sup>
Design compression force N,Ed	31.82	kN
Design bending moment (maximum) My,Ed	-10.39	kNm
Design bending moment (maximum) Mz,Ed	26.86	kNm
Characteristic compression resistance N,Rk	2601.50	kN
Characteristic moment resistance My,Rk	299.75	kNm
Characteristic moment resistance Mz,Rk	91.03	kNm
Reduction factor Chi,y	1.00	
Reduction factor Chi,z	1.00	
Reduction factor Chi,LT	1.00	
Interaction factor k,yy	1.01	
Interaction factor k,yz	0.60	
Interaction factor k,zy	1.01	
Interaction factor k,zz	0.60	

Maximum moment My,Ed is derived from beam B353 position 0.000 m.

Maximum moment Mz,Ed is derived from beam B353 position 5.031 m.

Interaction method 1 parameters		
<i>*Student version* *Student version* *Student version* *Student version* *Student version* *Student version* *Student</i>		
Critical Euler load N,cr,y	3377.60	kN
Critical Euler load N,cr,z	4061.31	kN
Elastic critical load N,cr,T	5746.83	kN
Cross-section elastic modulus Wel,y	1.0900e-03	m <sup>3</sup>
Second moment of area Iy	1.6500e-04	m <sup>4</sup>
Second moment of area Iz	4.9600e-05	m <sup>4</sup>
Torsional constant It	5.5900e-07	m <sup>4</sup>
Method for equivalent moment factor C,my,0	Table A.2 Line 2 (General)	
Design bending moment (maximum) My,Ed	-10.39	kNm
Maximum relative deflection delta,z	-1.3	mm
Equivalent moment factor C,my,0	0.99	
Method for equivalent moment factor C,mz,0	Table A.2 Line 1 (Linear)	
Ratio of end moments Psi,z	-0.93	
Equivalent moment factor C,mz,0	0.59	
Factor mu,y	1.00	
Factor mu,z	1.00	
Factor epsilon,y	2.83	
Factor a,LT	1.00	
Critical moment for uniform bending Mcr,0	727.64	kNm
Relative slenderness Lambda,rel,0	0.64	
Limit relative slenderness Lambda,rel,0,lim	0.31	
Equivalent moment factor C,my	1.00	
Equivalent moment factor C,mz	0.59	
Equivalent moment factor C,mLT	1.00	

Unity check (6.61) =  $0.01 + 0.03 + 0.18 = 0.22$  -

Unity check (6.62) =  $0.01 + 0.03 + 0.18 = 0.22$  -

### Shear Buckling check

According to EN 1993-1-5 article 5 & 7.1 and formula (5.10) & (7.1)

Shear Buckling parameters		
<i>*Student version*</i> <i>*Student version*</i> <i>*Student version*</i> <i>*Student version*</i>		
Buckling field length a	10.062	m
Web	unstiffened	
Web height hw	279	mm
Web thickness t	8	mm
Material coefficient epsilon	0.92	
Shear correction factor Eta	1.20	

Shear Buckling verification	
<i>*Student version*</i> <i>*Student version*</i> <i>*Student version*</i> <i>*Student version*</i>	
Web slenderness hw/t	34.87
Web slenderness limit	55.46

**Note:** The web slenderness is such that Shear Buckling effects may be ignored according to EN 1993-1-5 article 5.1(2).

The member satisfies the stability check.

pdfelement

#### 4.6 Dimenzioniranje dijagonale krovnog nosača

Dimenzioniranje konstrukcijskih elemenata je provedena softverom Scia Engineer 2016 pomoću modula Steel.

Uzdužna sila u dijagonali (N)

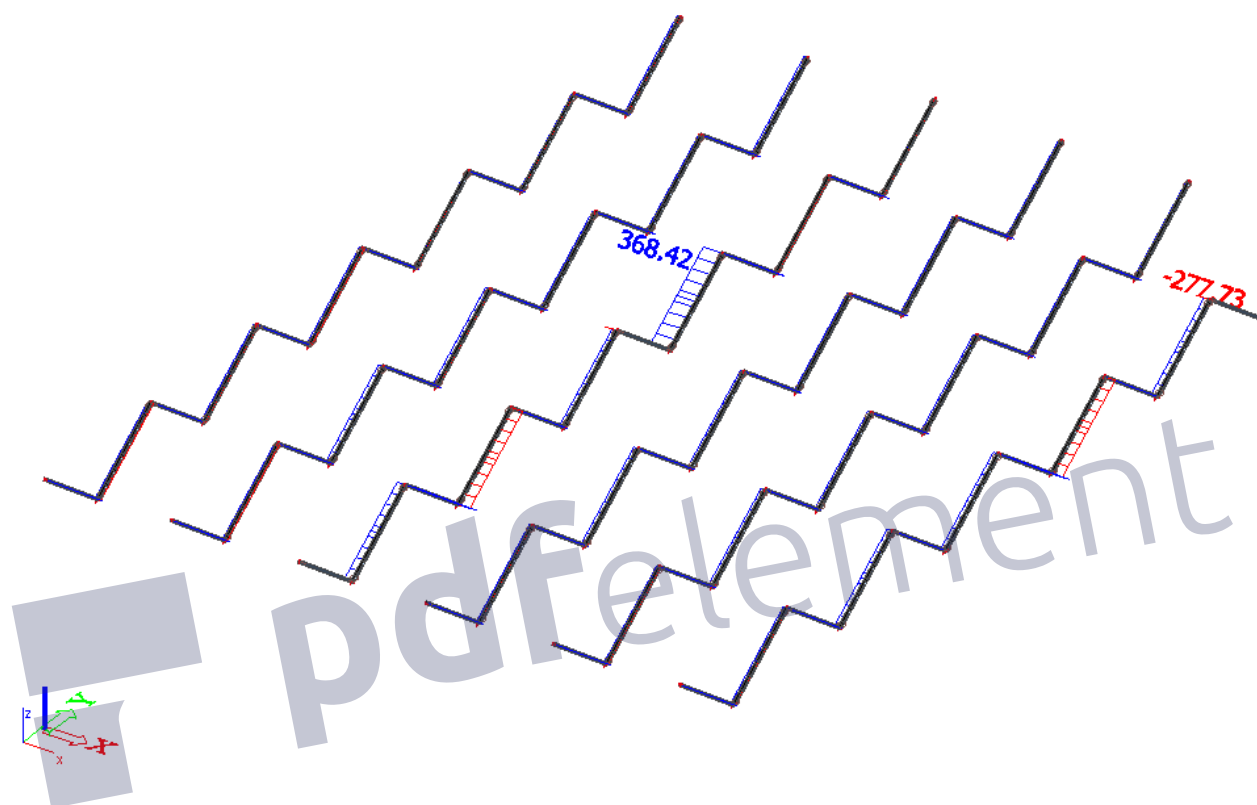

Slika 47: Vrijednosti uzdužne sile

Poprečna sila u dijagonali (Vy)

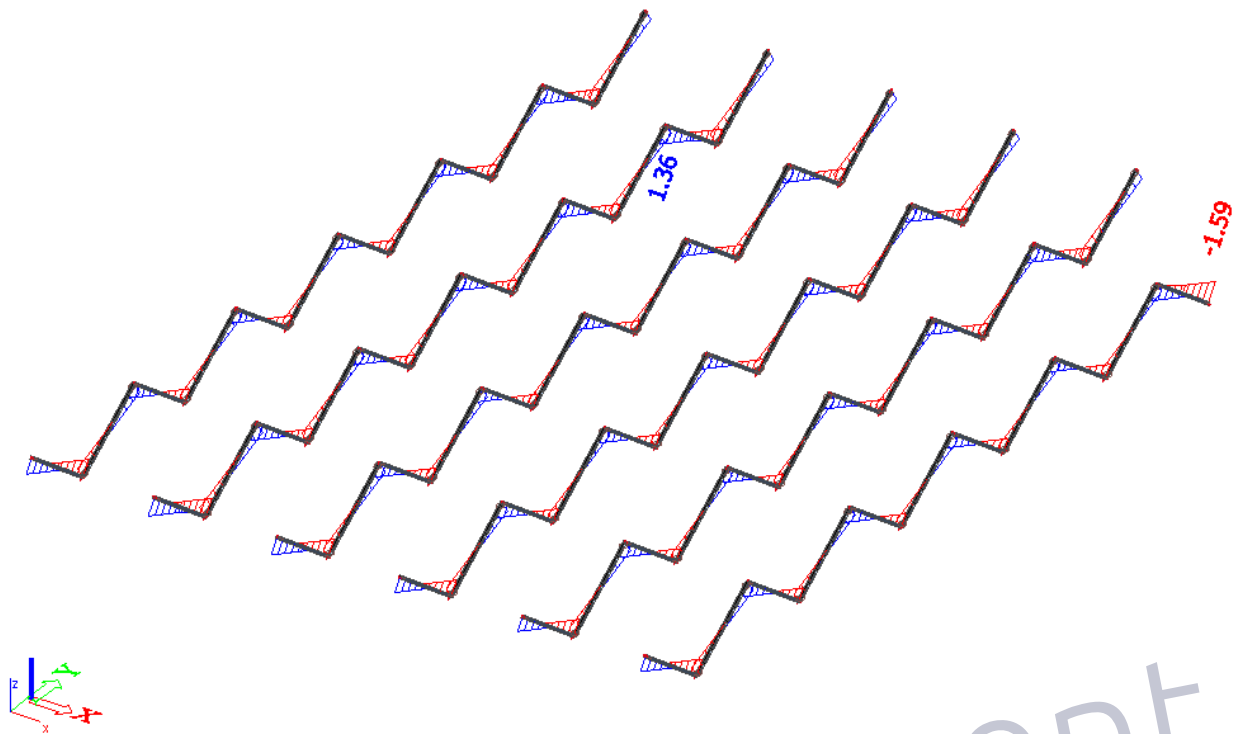

Slika 48: Vrijednosti poprečne sile

Prikaz iskoristivosti elementa

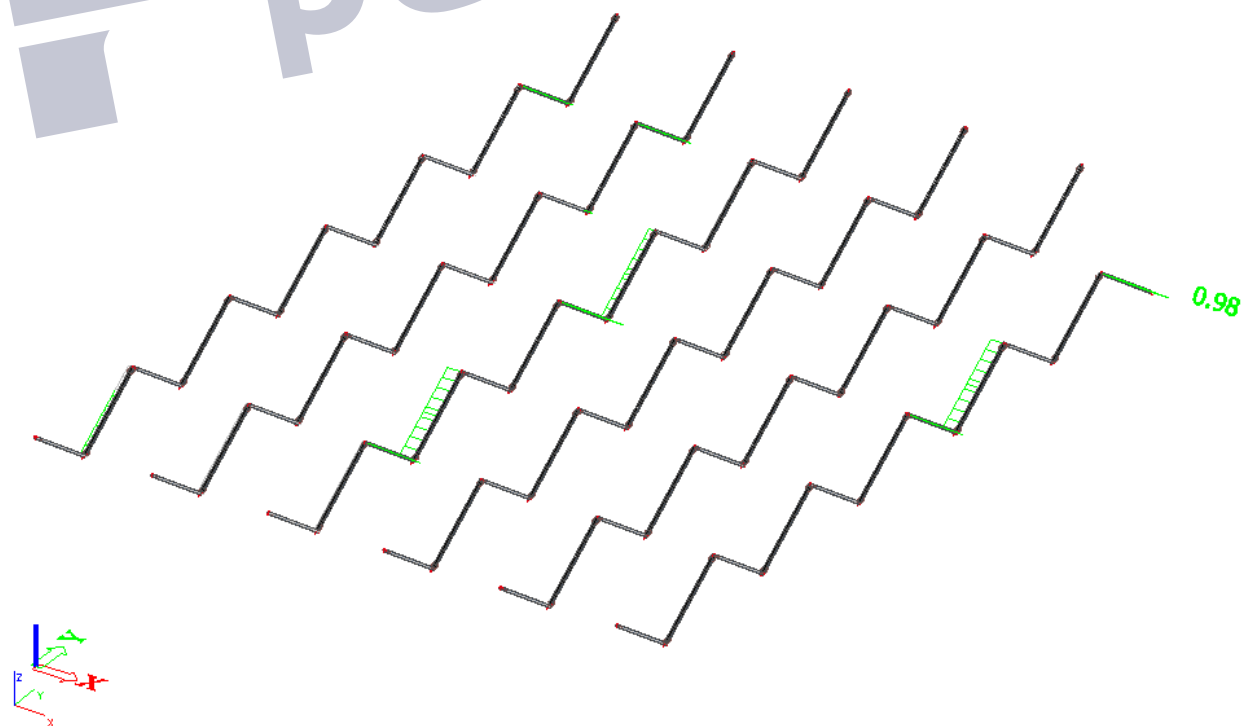

Slika 49: Prikaz iskoristivosti dijagonale krovne rešetke

Poprečni presjek elementa

Name	CS32
Type	HEA180A
Source description	Profil Arbed / Structural shapes / Edition Octobre 1995
Item material	S 275
Fabrication	rolled
Flexural buckling y-y	b
Flexural buckling z-z	c
Lateral torsional buckling	Default
Use 2D FEM analysis	x

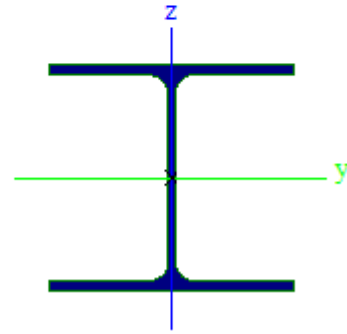

A [m <sup>2</sup> ]	3.6500e-03	
A <sub>y, z</sub> [m <sup>2</sup> ]	2.6006e-03	8.9500e-04
I <sub>y, z</sub> [m <sup>4</sup> ]	1.9700e-05	7.3000e-06
I <sub>w</sub> [m <sup>6</sup> ], I <sub>t</sub> [m <sup>4</sup> ]	4.6365e-08	8.3300e-08
W <sub>el y, z</sub> [m <sup>3</sup> ]	2.3600e-04	8.1100e-05
W <sub>pl y, z</sub> [m <sup>3</sup> ]	2.5833e-04	1.2375e-04
d <sub>y, z</sub> [mm]	0	0
c <sub>YUCS, ZUCS</sub> [mm]	90	83
α [deg]	0.00	
A <sub>L, D</sub> [m <sup>2</sup> /m]	1.0200e+00	1.0181e+00
M <sub>ply +, -</sub> [Nm]	7.11e+04	7.11e+04
M <sub>plz +, -</sub> [Nm]	3.40e+04	3.40e+04

Dimenzioniranje elementa je provedeno u softveru (modul Steel)

<b>Member B254</b>	<b>6.103 m</b>	<b>HEA180A</b>	<b>S 275</b>	<b>GSN 4</b>	<b>0.98 -</b>
--------------------	----------------	----------------	--------------	--------------	---------------

Partial safety factors	
<i>*Student version* *Student version* *Student version* *Student version* *</i>	
Gamma M0 for resistance of cross-sections	1.00
Gamma M1 for resistance to instability	1.00
Gamma M2 for resistance of net sections	1.25

Material		
<i>*Student version* *Student version* *Student version* *</i>		
Yield strength $f_y$	275.0	MPa
Ultimate strength $f_u$	430.0	MPa
Fabrication	Rolled	

**...:SECTION CHECK:...:**

The critical check is on position **0.000 m**

Internal forces	Calculated	Unit
<i>*Student version* *Student version* *Student version* *</i>		
N,Ed	-277.73	kN
V <sub>y</sub> ,Ed	-0.92	kN
V <sub>z</sub> ,Ed	0.00	kN
T,Ed	0.00	kNm
M <sub>y</sub> ,Ed	0.00	kNm
M <sub>z</sub> ,Ed	0.84	kNm

**Classification for cross-section design**

According to EN 1993-1-1 article 5.5.2

**Classification of Internal Compression parts**

According to EN 1993-1-1 Table 5.2 Sheet 1

Maximum width-to-thickness ratio	24.40
Class 1 Limit	30.51
Class 2 Limit	35.13
Class 3 Limit	38.83

=> Internal Compression parts Class 1

**Classification of Outstand Flanges**

According to EN 1993-1-1 Table 5.2 Sheet 2

Maximum width-to-thickness ratio	9.67
Class 1 Limit	8.32
Class 2 Limit	9.24
Class 3 Limit	12.84

=> Outstand Flanges Class 3

=> Section classified as Class 3 for cross-section design

**Compression check**

According to EN 1993-1-1 article 6.2.4 and formula (6.9)

A	3.6500e-03	m <sup>2</sup>
N <sub>c,Rd</sub>	1003.75	kN
Unity check	0.28	-

**Bending moment check for Mz**

According to EN 1993-1-1 article 6.2.5 and formula (6.12),(6.14)

W <sub>el,z</sub> min	8.1100e-05	m <sup>3</sup>
M <sub>el,z</sub> Rd	22.30	kNm
Unity check	0.04	-

**Shear check for V<sub>y</sub>**

According to EN 1993-1-1 article 6.2.6 and formula (6.17)

Eta	1.20	
A <sub>v</sub>	2.8000e-03	m <sup>2</sup>
V <sub>pl,y</sub> Rd	444.56	kN
Unity check	0.00	-

**Torsion check**

According to EN 1993-1-1 article 6.2.7 and formula (6.23)

Tau <sub>t</sub> Ed	0.3	MPa
Tau <sub>t</sub> Rd	158.8	MPa
Unity check	0.00	-

**Note:** The unity check for torsion is lower than the limit value of 0.05. Therefore torsion is considered as insignificant and is ignored in the combined checks.

**Combined bending, axial force and shear force check**

According to EN 1993-1-1 article 6.2.9.2 and formula (6.42)

Normal stresses		
<i>*Student version* *Student version* *Student vers</i>		
Fibre	3	
Sigma <sub>N</sub> Ed	76.1	MPa
Sigma <sub>My</sub> Ed	0.0	MPa
Sigma <sub>Mz</sub> Ed	10.4	MPa
Sigma <sub>tot</sub> Ed	86.5	MPa
Unity check	0.31	-

The member satisfies the section check.

**...::STABILITY CHECK:...::****Classification for member buckling design**

Decisive position for stability classification: 0.000 m

**Classification of Internal Compression parts**

According to EN 1993-1-1 Table 5.2 Sheet 1

Maximum width-to-thickness ratio	24.40
Class 1 Limit	30.51
Class 2 Limit	35.13
Class 3 Limit	38.83

=&gt; Internal Compression parts Class 1

**Classification of Outstand Flanges**

According to EN 1993-1-1 Table 5.2 Sheet 2



Maximum width-to-thickness ratio	9.67
Class 1 Limit	8.32
Class 2 Limit	9.24
Class 3 Limit	12.84

=> Outstand Flanges Class 3

=> Section classified as Class 3 for member buckling design

### Flexural Buckling check

According to EN 1993-1-1 article 6.3.1.1 and formula (6.46)

Buckling parameters	YY	ZZ	
<i>*Student version* *Student version* *Student version* *Student version* *Student version*</i>			
Sway type	sway	non-sway	
System length L	6.103	6.103	m
Buckling factor k	1.00	1.00	
Buckling length Lcr	6.103	6.103	m
Critical Euler load Ncr	1096.12	406.18	kN
Slenderness Lambda	83.08	136.47	
Relative slenderness Lambda,rel	0.96	1.57	
Limit slenderness Lambda,rel,0	0.20	0.20	
Buckling curve	b	c	
Imperfection Alpha	0.34	0.49	
Reduction factor Chi	0.62	0.29	
Buckling resistance Nb,Rd	626.88	293.39	kN

Flexural Buckling verification		
<i>*Student version* *Student version* *Student version* *Student version* *Stu</i>		
Cross-section area A	3.6500e-03	m <sup>2</sup>
Buckling resistance Nb,Rd	293.39	kN
Unity check	0.95	-

### Torsional(-Flexural) Buckling check

According to EN 1993-1-1 article 6.3.1.1 and formula (6.46)

**Note:** For this I-section the Torsional(-Flexural) buckling resistance is higher than the resistance for Flexural buckling. Therefore Torsional(-Flexural) buckling is not printed on the output.

### Bending and axial compression check

According to EN 1993-1-1 article 6.3.3 and formula (6.61),(6.62)

Bending and axial compression check parameters		
<i>*Student version* *Student version* *Student version* *Student version* *Student version* *Student v</i>		
Interaction method	alternative method 1	
Cross-section area A	3.6500e-03	m <sup>2</sup>
Cross-section elastic modulus Wel,z	8.1100e-05	m <sup>3</sup>
Design compression force N,Ed	277.73	kN
Design bending moment (maximum) My,Ed	0.00	kNm
Design bending moment (maximum) Mz,Ed	1.03	kNm
Characteristic compression resistance N,Rk	1003.75	kN
Characteristic moment resistance Mz,Rk	22.30	kNm
Reduction factor Chi,y	0.62	
Reduction factor Chi,z	0.29	
Reduction factor Chi,LT	1.00	
Interaction factor k,yz	1.52	
Interaction factor k,zz	0.68	

Maximum moment  $M_{y,Ed}$  is derived from beam B254 position 0.000 m.  
Maximum moment  $M_{z,Ed}$  is derived from beam B254 position 6.103 m.

Interaction method 1 parameters		
<i>*Student version* *Student version* *Student version* *Student version* *Student version* *Student version* *Student version*</i>		
Critical Euler load $N_{cr,y}$	1096.12	kN
Critical Euler load $N_{cr,z}$	406.18	kN
Elastic critical load $N_{cr,T}$	1258.28	kN
Second moment of area $I_y$	1.9700e-05	m <sup>4</sup>
Second moment of area $I_z$	7.3000e-06	m <sup>4</sup>
Torsional constant $I_t$	8.3300e-08	m <sup>4</sup>
Method for equivalent moment factor $C_{mz,0}$	Table A.2 Line 2 (General)	
Design bending moment (maximum) $M_{z,Ed}$	1.03	kNm
Maximum relative deflection $\delta_{rel,y}$	0.8	mm
Equivalent moment factor $C_{mz,0}$	0.54	
Factor $\mu_y$	0.89	
Factor $\mu_z$	0.40	
Factor $a_{LT}$	1.00	
Critical moment for uniform bending $M_{cr,0}$	61.49	kNm
Relative slenderness $\lambda_{rel,0}$	1.03	
Equivalent moment factor $C_{mz}$	0.54	

Unity check (6.61) =  $0.44 + 0.00 + 0.07 = 0.51$  -

Unity check (6.62) =  $0.95 + 0.00 + 0.03 = 0.98$  -

The member satisfies the stability check.



#### 4.7 Dimenzioniranje krovne podrožnice

Dimenzioniranje konstrukcijskih elemenata je provedena softverom Scia Engineer 2016 pomoću modula Steel.

Uzdužna sila u krovnoj podrožnici (N)

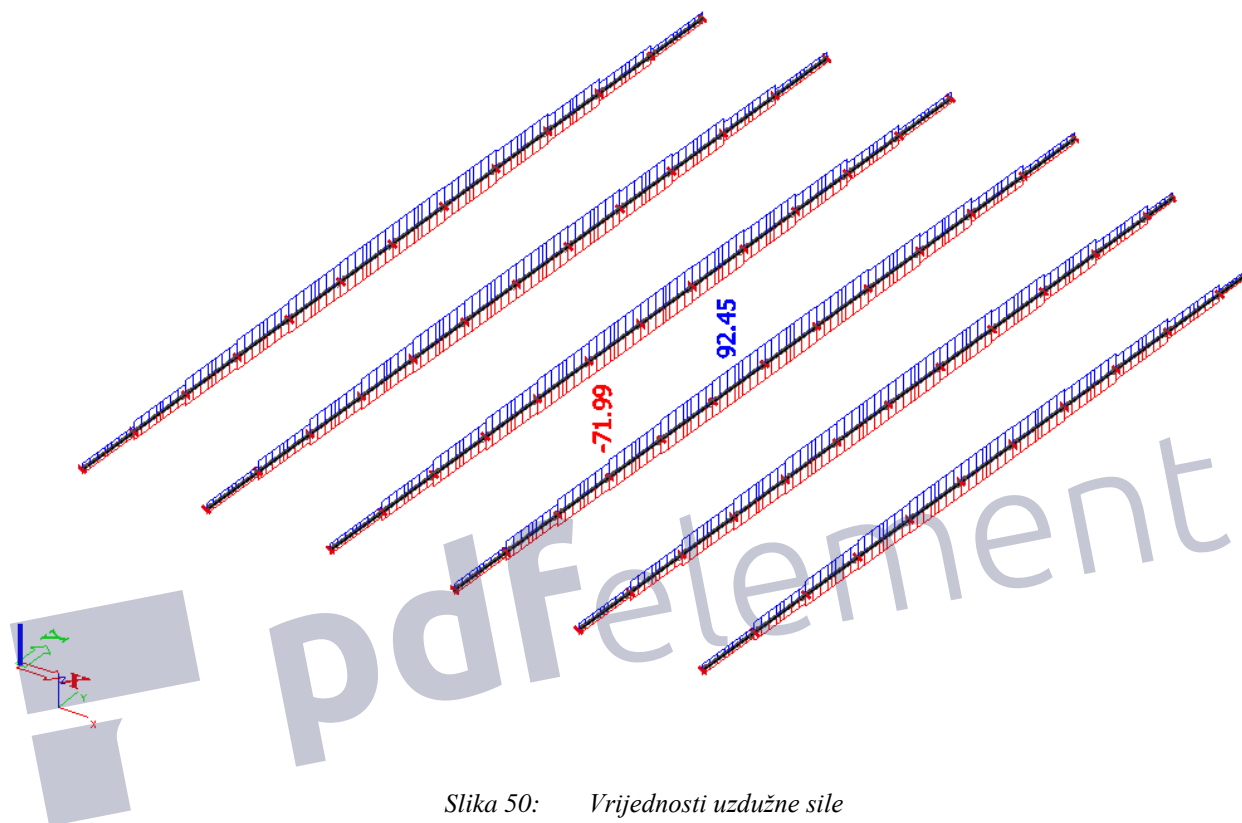

Slika 50: Vrijednosti uzdužne sile

Prikaz iskoristivosti elementa

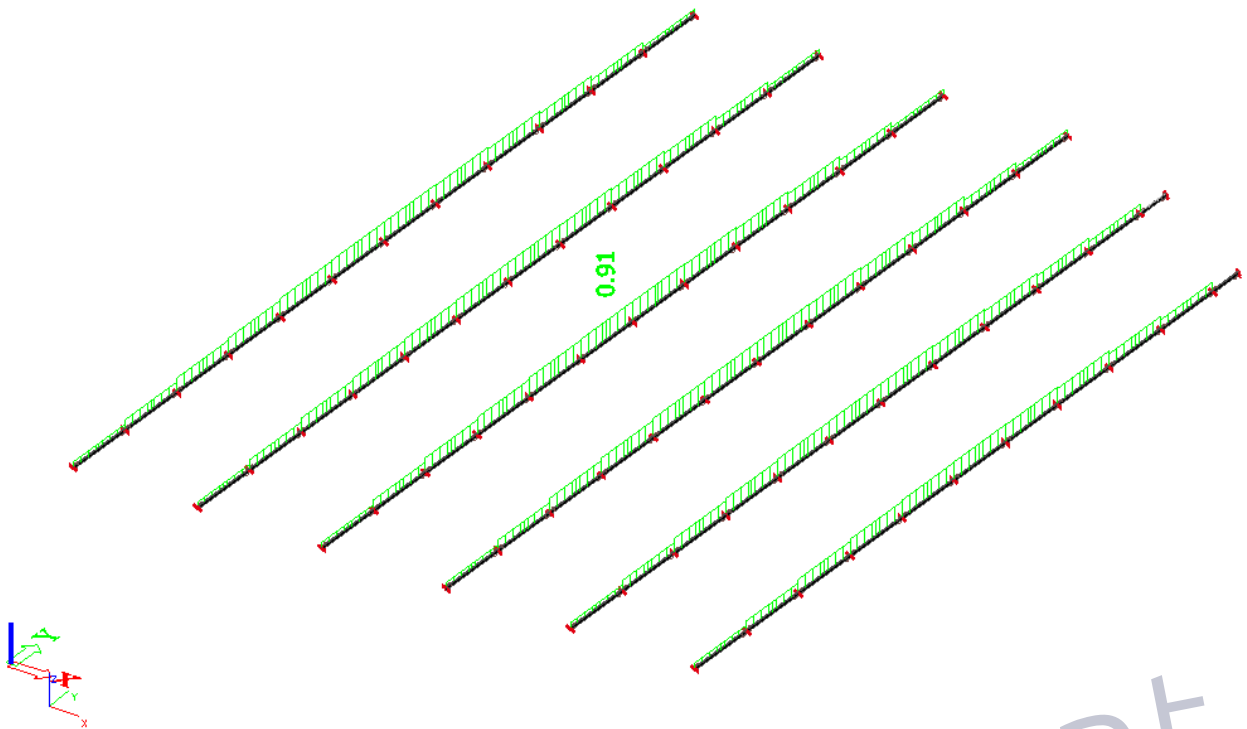

Slika 51: Prikaz iskoristivosti krovne podrožnice

Poprečni presjek elementa

Name	CS25
Type	U180
Source description	Stahl im Hochbau / 14.Auflage Band I / Teil 1
Item material	S 275
Fabrication	rolled
Flexural buckling y-y	c
Flexural buckling z-z	c
Lateral torsional buckling	Default
Use 2D FEM analysis	x

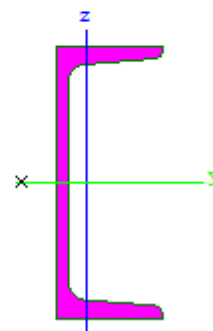

A [m <sup>2</sup> ]	2.8000e-03	
A <sub>y, z</sub> [m <sup>2</sup> ]	1.4920e-03	1.4353e-03
I <sub>y, z</sub> [m <sup>4</sup> ]	1.3500e-05	1.1400e-06
I <sub>w</sub> [m <sup>6</sup> ], t [m <sup>4</sup> ]	6.4377e-09	9.5500e-08
W <sub>el y, z</sub> [m <sup>3</sup> ]	1.5000e-04	2.2400e-05
W <sub>pl y, z</sub> [m <sup>3</sup> ]	1.8225e-04	4.3056e-05
d <sub>y, z</sub> [mm]	-42	0
c <sub>YUCS, ZUCS</sub> [mm]	19	90
α [deg]	0.00	
A <sub>L, D</sub> [m <sup>2</sup> /m]	6.1000e-01	6.0268e-01
M <sub>pl y, -</sub> [Nm]	4.93e+04	4.93e+04
M <sub>pl z, -</sub> [Nm]	1.18e+04	1.18e+04

Dimenzioniranje elementa je provedeno u softveru (modul Steel)

<b>Member B820</b>	<b>5.000 m</b>	<b>U180</b>	<b>S 275</b>	<b>GSN 10</b>	<b>0.91 -</b>
--------------------	----------------	-------------	--------------	---------------	---------------

**Partial safety factors**

*\*Student version\* \*Student version\* \*Student version\* \*Student version\* \**

Gamma M0 for resistance of cross-sections	1.00
Gamma M1 for resistance to instability	1.00
Gamma M2 for resistance of net sections	1.25

**Material**

*\*Student version\* \*Student version\* \*Student version\* \**

Yield strength f <sub>y</sub>	275.0	MPa
Ultimate strength f <sub>u</sub>	430.0	MPa
Fabrication	Rolled	

**...:SECTION CHECK:...:**

The critical check is on position **2.500 m**

**Internal forces**    **Calculated**    **Unit**

*\*Student version\* \*Student version\* \*Student version\* \**

N <sub>,Ed</sub>	-71.99	kN
V <sub>y,Ed</sub>	0.01	kN
V <sub>z,Ed</sub>	0.00	kN
T <sub>,Ed</sub>	0.00	kNm
M <sub>y,Ed</sub>	0.91	kNm
M <sub>z,Ed</sub>	0.01	kNm

**Classification for cross-section design**

According to EN 1993-1-1 article 5.5.2

**Classification of Internal Compression parts**

According to EN 1993-1-1 Table 5.2 Sheet 1

Maximum width-to-thickness ratio	17.00
Class 1 Limit	30.51
Class 2 Limit	35.13
Class 3 Limit	43.22

=&gt; Internal Compression parts Class 1

**Classification of Outstand Flanges**

According to EN 1993-1-1 Table 5.2 Sheet 2

Maximum width-to-thickness ratio	4.64
Class 1 Limit	8.32
Class 2 Limit	9.24
Class 3 Limit	12.74

=&gt; Outstand Flanges Class 1

=&gt; Section classified as Class 1 for cross-section design

**Compression check**

According to EN 1993-1-1 article 6.2.4 and fomula (6.9)

A	2.8000e-03	m <sup>2</sup>
N <sub>c,Rd</sub>	770.00	kN
Unity check	0.09	-

**Bending moment check for M<sub>y</sub>**

According to EN 1993-1-1 article 6.2.5 and fomula (6.12),(6.13)

W <sub>pl,y</sub>	1.8225e-04	m <sup>3</sup>
M <sub>pl,y,Rd</sub>	50.12	kNm
Unity check	0.02	-

**Bending moment check for M<sub>z</sub>**

According to EN 1993-1-1 article 6.2.5 and fomula (6.12),(6.13)

W <sub>pl,z</sub>	4.3056e-05	m <sup>3</sup>
M <sub>pl,z,Rd</sub>	11.84	kNm
Unity check	0.00	-

**Shear check for V<sub>y</sub>**

According to EN 1993-1-1 article 6.2.6 and fomula (6.17)

E <sub>t</sub>	1.20	
A <sub>v</sub>	1.5400e-03	m <sup>2</sup>
V <sub>pl,y,Rd</sub>	244.51	kN
Unity check	0.00	-

**Torsion check**

According to EN 1993-1-1 article 6.2.7 and fomula (6.23)

Tau <sub>t,Ed</sub>	0.0	MPa
Tau <sub>Rd</sub>	158.8	MPa
Unity check	0.00	-

**Note:** The unity check for torsion is lower than the limit value of 0.05. Therefore torsion is considered as insignificant and is ignored in the combined checks.

**Combined bending, axial force and shear force check**

According to EN 1993-1-1 article 6.2.1 and formula (6.2)

Npl,Rd	770.00	kN
Mpl,y,Rd	50.12	kNm
Mpl,z,Rd	11.84	kNm

Unity check (6.2) = 0.09 + 0.02 + 0.00 = 0.11 -

**Note:** No specific interaction formulae according to EN 1993-1-1 article 6.2.9.1 apply.

Therefore the plastic linear summation according to EN 1993-1-1 article 6.2.1(7) is verified.

**Note:** Since the shear forces are less than half the plastic shear resistances their effect on the moment resistances is neglected.

The member satisfies the section check.

**...::STABILITY CHECK::...**

**Classification for member buckling design**

Decisive position for stability classification: 0.000 m

**Classification of Internal Compression parts**

According to EN 1993-1-1 Table 5.2 Sheet 1

Maximum width-to-thickness ratio	17.00
Class 1 Limit	30.51
Class 2 Limit	35.13
Class 3 Limit	38.83

=> Internal Compression parts Class 1

**Classification of Outstand Flanges**

According to EN 1993-1-1 Table 5.2 Sheet 2

Maximum width-to-thickness ratio	4.64
Class 1 Limit	8.32
Class 2 Limit	9.24
Class 3 Limit	12.90

=> Outstand Flanges Class 1

=> Section classified as Class 1 for member buckling design

**Flexural Buckling check**

According to EN 1993-1-1 article 6.3.1.1 and formula (6.46)

Buckling parameters	yy	zz	
<i>*Student version* *Student version* *Student version* *Student version* *Student version*</i>			
Sway type	sway	non-sway	
System length L	5.000	5.000	m
Buckling factor k	1.00	1.00	
Buckling length Lcr	5.000	5.000	m
Critical Euler load Ncr	1119.21	94.51	kN
Slenderness Lambda	72.01	247.80	
Relative slenderness Lambda,rel	0.83	2.85	
Limit slenderness Lambda,rel,0	0.20	0.20	
Buckling curve	c	c	
Imperfection Alpha	0.49	0.49	
Reduction factor Chi	0.64	0.10	
Buckling resistance Nb,Rd	495.63	80.22	kN

**Warning:** Slenderness 247.80 is larger than the limit value of 200.00.

Flexural Buckling verification		
<i>*Student version* *Student version* *Student version* *Student version* *Stu</i>		
Cross-section area A	2.8000e-03	m <sup>2</sup>
Buckling resistance Nb,Rd	80.22	kN
Unity check	0.90	-

**Torsional(-Flexural) Buckling check**

According to EN 1993-1-1 article 6.3.1.1 and formula (6.46)

Torsional buckling length Lcr	5.000	m
Elastic critical load Ncr,T	1175.57	kN
Elastic critical load Ncr,TF	94.51	kN
Relative slenderness Lambda,rel,T	2.85	
Limit slenderness Lambda,rel,0	0.20	
Buckling curve	c	
Imperfection Alpha	0.49	
Reduction factor Chi	0.10	
Cross-section area A	2.8000e-03	m <sup>2</sup>
Buckling resistance Nb,Rd	80.22	kN
Unity check	0.90	-

**Lateral Torsional Buckling check**

According to EN 1993-1-1 article 6.3.2.1 & 6.3.2.2 and formula (6.54)

LTB parameters		
<i>*Student version* *Student version* *Student version* *Student version* *Student version* *</i>		
Method for LTB curve	General case	
Cross-section plastic modulus Wpl,y	1.8225e-04	m <sup>3</sup>
Elastic critical moment Mcr	31.46	kNm
Relative slenderness Lambda,rel,LT	1.26	
Relative slenderness Lambda,rel,T	0.06	
Relative slenderness Lambda,rel,EXTRA	1.33	
Limit slenderness Lambda,rel,LT,0	0.20	

**Note:** The slenderness or bending moment is such that Lateral Torsional Buckling effects may be ignored according to EN 1993-1-1 article 6.3.2.2(4).

**Note:** Lambda,rel,EXTRA is determined according to "Design rule for lateral torsional buckling of channel sections, 2007".

Mcr parameters		
<i>*Student version* *Student version* *Student version* *Student version* *Stu</i>		
LTB length L	5.000	m
Influence of load position	no influence	
Correction factor k	1.00	
Correction factor kw	1.00	
LTB moment factor C1	1.13	
LTB moment factor C2	0.45	
LTB moment factor C3	0.53	
Shear center distance d,z	0	mm
Distance of load application z,g	0	mm
Mono-symmetry constant beta,y	0	mm
Mono-symmetry constant z,j	0	mm



**Note:** C parameters are determined according to ECCS 119 2006 / Galea 2002.

### Bending and axial compression check

According to EN 1993-1-1 article 6.3.3 and formula (6.61),(6.62)

Bending and axial compression check parameters		
<i>*Student version* *Student version* *Student version* *Student version* *Student version* *Student version* *Student v</i>		
Interaction method	alternative method 1	
Cross-section area A	2.8000e-03	m <sup>2</sup>
Cross-section plastic modulus Wpl,y	1.8225e-04	m <sup>3</sup>
Cross-section plastic modulus Wpl,z	4.3056e-05	m <sup>3</sup>
Design compression force N,Ed	71.99	kN
Design bending moment (maximum) My,Ed	0.91	kNm
Design bending moment (maximum) Mz,Ed	0.03	kNm
Characteristic compression resistance N,Rk	770.00	kN
Characteristic moment resistance My,Rk	50.12	kNm
Characteristic moment resistance Mz,Rk	11.84	kNm
Reduction factor Chi,y	0.64	
Reduction factor Chi,z	0.10	
Reduction factor Chi,LT	1.00	
Interaction factor k,yy	2.67	
Interaction factor k,yz	1.35	
Interaction factor k,zy	0.71	
Interaction factor k,zz	0.52	

Maximum moment My,Ed is derived from beam B820 position 2.500 m.

Maximum moment Mz,Ed is derived from beam B820 position 5.000 m.

Interaction method 1 parameters		
<i>*Student version* *Student version* *Student version* *Student version* *Student version* *Student version* *Student ver</i>		
Critical Euler load N,cr,y	1119.21	kN
Critical Euler load N,cr,z	94.51	kN
Elastic critical load N,cr,T	1175.57	kN
Cross-section plastic modulus Wpl,y	1.8225e-04	m <sup>3</sup>
Cross-section elastic modulus Wel,y	1.5000e-04	m <sup>3</sup>
Cross-section plastic modulus Wpl,z	4.3056e-05	m <sup>3</sup>
Cross-section elastic modulus Wel,z	2.2400e-05	m <sup>3</sup>
Second moment of area Iy	1.3500e-05	m <sup>4</sup>
Second moment of area Iz	1.1400e-06	m <sup>4</sup>
Torsional constant It	9.5500e-08	m <sup>4</sup>
Method for equivalent moment factor C,my,0	Table A.2 Line 4 (Line load)	
Equivalent moment factor C,my,0	1.00	
Method for equivalent moment factor C,mz,0	Table A.2 Line 1 (Linear)	
Ratio of end moments Psi,z	-0.49	
Equivalent moment factor C,mz,0	0.46	
Factor mu,y	0.98	
Factor mu,z	0.26	
Factor epsilon,y	0.24	
Factor a,LT	0.99	
Critical moment for uniform bending Mcr,0	27.92	kNm
Relative slenderness Lambda,rel,0	1.34	
Limit relative slenderness Lambda,rel,0,lim	0.15	
Equivalent moment factor C,my	1.00	
Equivalent moment factor C,mz	0.46	
Equivalent moment factor C,mLT	2.10	
Factor b,LT	0.00	
Factor c,LT	0.00	
Factor d,LT	0.00	

Factor e,LT	0.00	
Factor w,y	1.21	
Factor w,z	1.50	
Factor n,pl	0.09	
Maximum relative slenderness Lambda,rel,max	2.85	
Factor C,yy	0.82	
Factor C,yz	0.94	
Factor C,zy	0.44	
Factor C,zz	0.98	

Unity check (6.61) =  $0.15 + 0.05 + 0.00 = 0.20$  -

Unity check (6.62) =  $0.90 + 0.01 + 0.00 = 0.91$  -

The member satisfies the stability check.

 pdfelement

#### 4.8 Dimenzioniranje krovne horizontalne grede

Dimenzioniranje konstrukcijskih elemenata je provedena softverom Scia Engineer 2016 pomoću modula Steel.

Uzdužna sila u krovnoj horizontalnoj gredi (N)

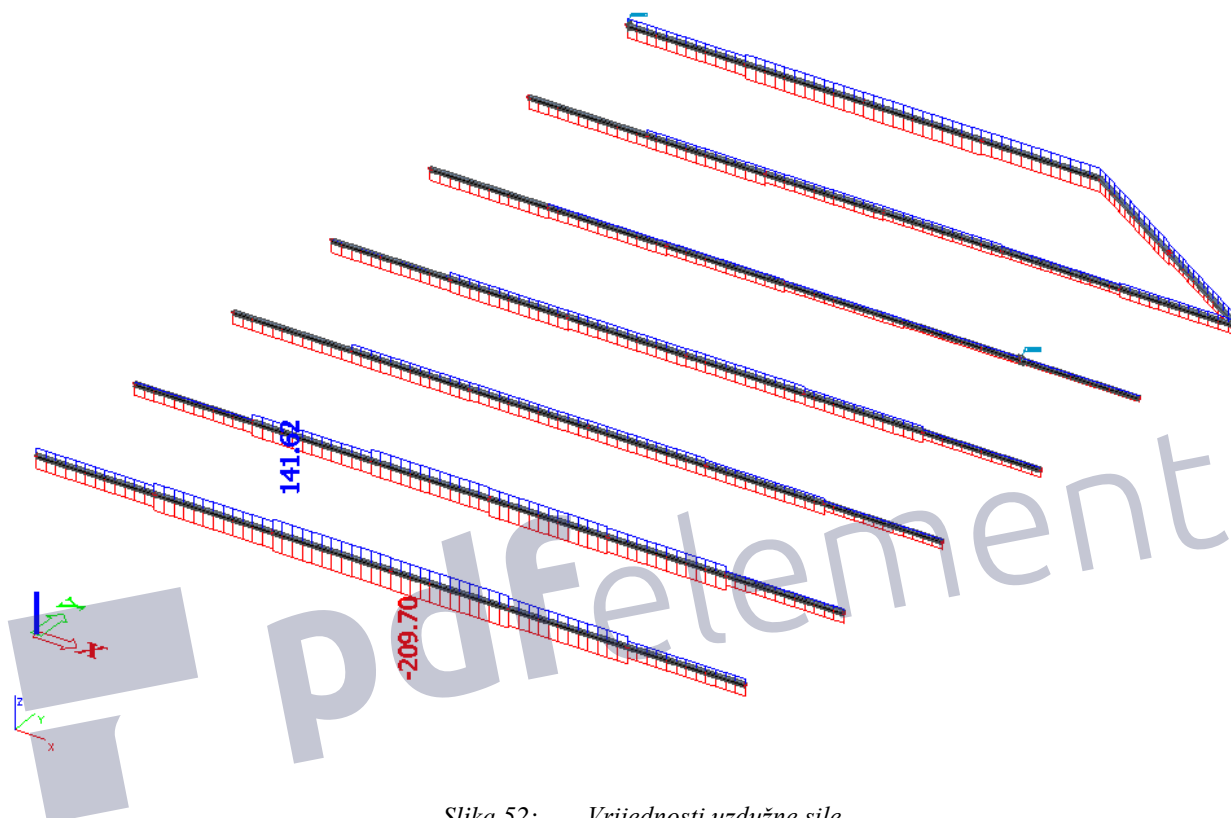

Slika 52: Vrijednosti uzdužne sile

Poprečna sila u pojasnici kovnog nosača(Vz)

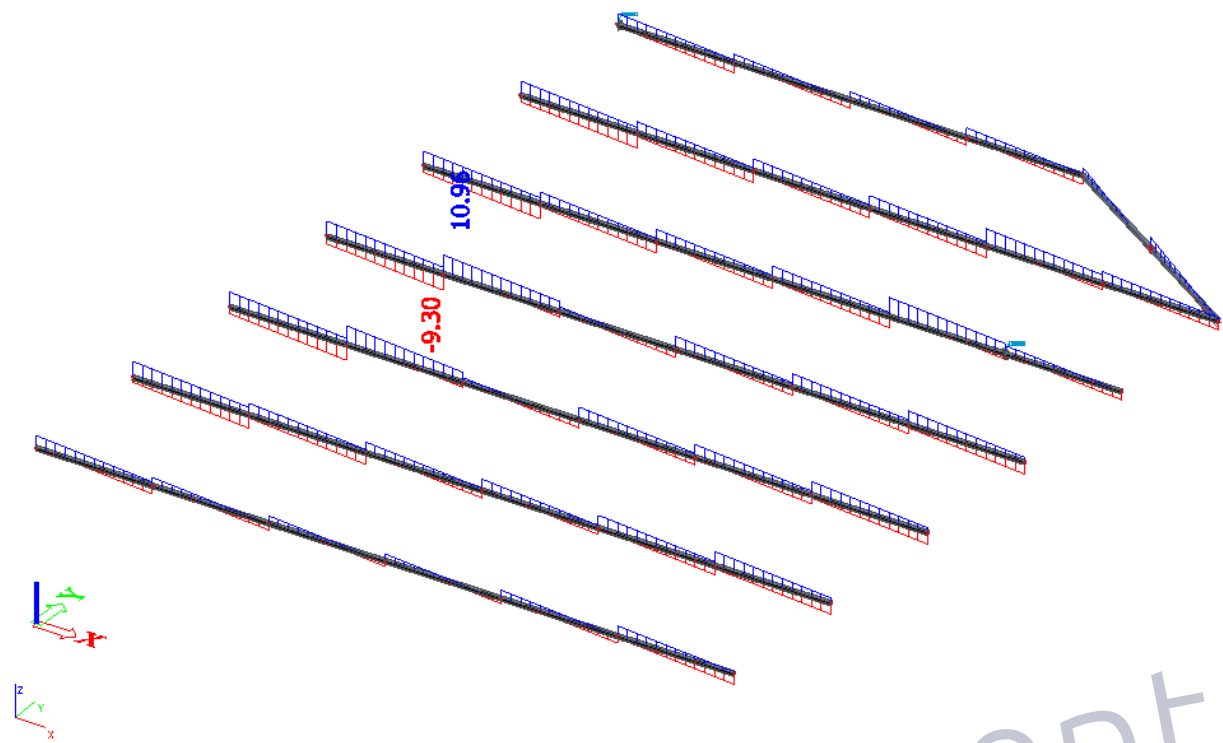

Slika 53: Vrijednosti poprečne sile

Moment savijanja u pojasnici krovnog nosača (My)

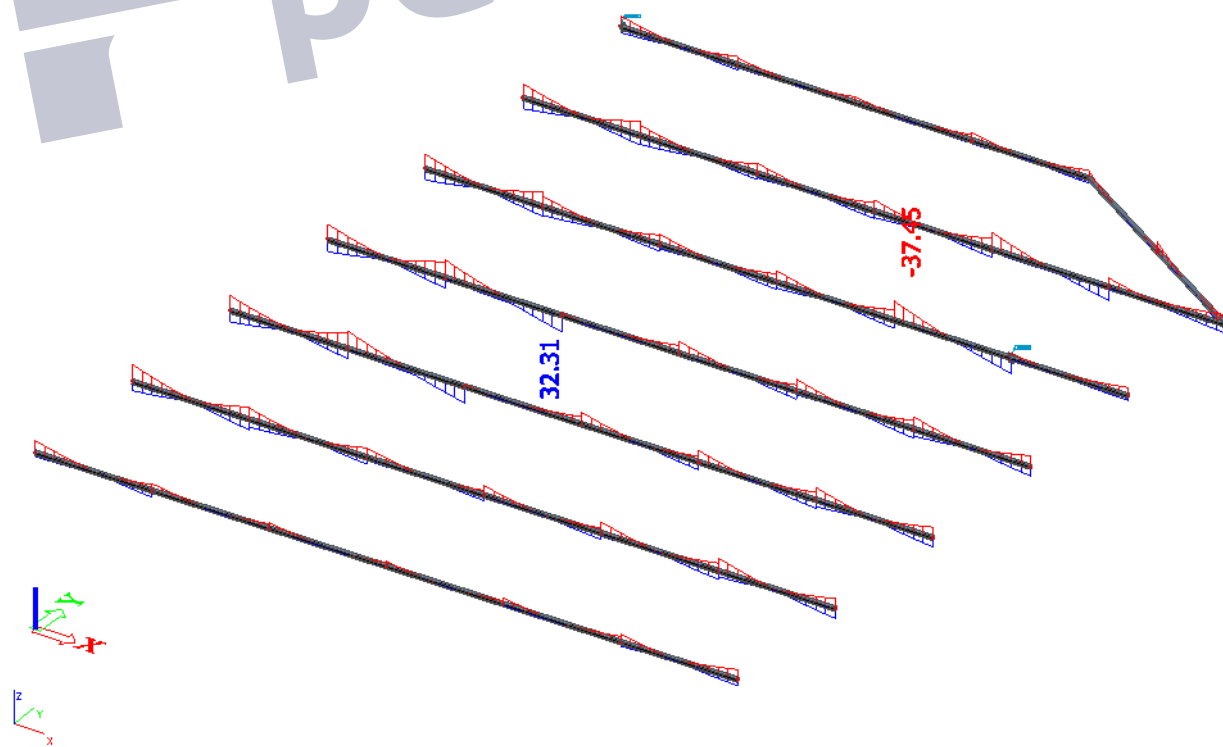

Slika 54: Vrijdnosti momenta savijanja

Prikaz iskoristivosti elementa

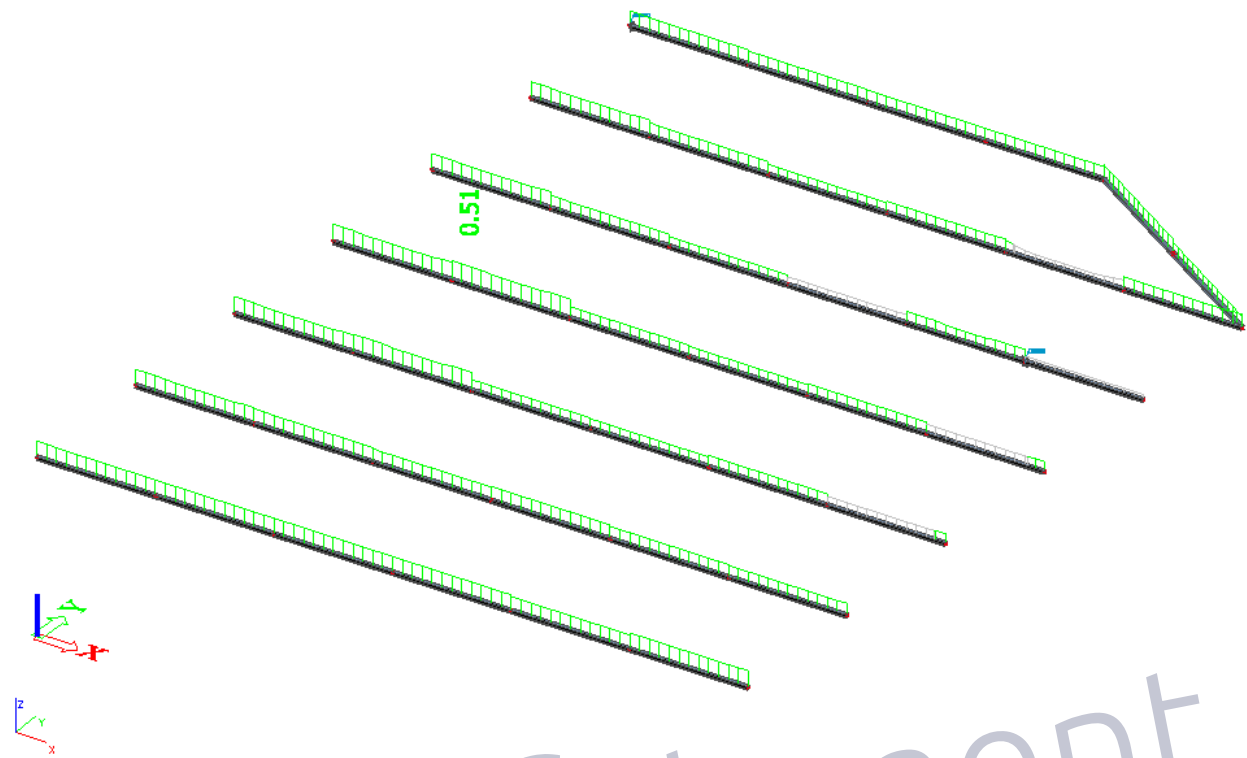

Slika 55: Prikaz iskoristivosti elementa

Poprečni presjek elementa

Name	CS5
Type	HEA240A
Source description	Profil Arbed / Structural shapes / Edition Octobre 1995
Item material	S 275
Fabrication	rolled
Flexural buckling y-y	b
Flexural buckling z-z	c
Lateral torsional buckling	Default
Use 2D FEM analysis	✘

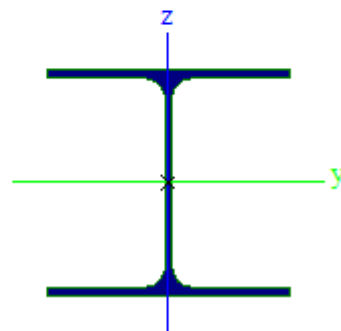

A [m <sup>2</sup> ]	6.0400e-03	
A <sub>y, z</sub> [m <sup>2</sup> ]	4.2119e-03	1.5693e-03
I <sub>y, z</sub> [m <sup>4</sup> ]	5.8400e-05	2.0800e-05
I <sub>w</sub> [m <sup>6</sup> ], t [m <sup>4</sup> ]	2.3963e-07	2.3000e-07
W <sub>el y, z</sub> [m <sup>3</sup> ]	5.2100e-04	1.7300e-04
W <sub>pl y, z</sub> [m <sup>3</sup> ]	5.7083e-04	2.6250e-04
d <sub>y, z</sub> [mm]	0	0
c <sub>YUCS, ZUCS</sub> [mm]	120	112
α [deg]	0.00	
A <sub>L, D</sub> [m <sup>2</sup> /m]	1.3600e+00	1.3588e+00
M <sub>pl y, -</sub> [Nm]	1.57e+05	1.57e+05
M <sub>pl z, -</sub> [Nm]	7.27e+04	7.27e+04

Dimenzioniranje elementa je provedeno u softveru (modul Steel)

<b>Member B297</b>	<b>8.000 m</b>	<b>HEA240A</b>	<b>S 275</b>	<b>GSN 9</b>	<b>0.42 -</b>
--------------------	----------------	----------------	--------------	--------------	---------------

Partial safety factors	
<i>*Student version* *Student version* *Student version* *Student version* *</i>	
Gamma M0 for resistance of cross-sections	1.00
Gamma M1 for resistance to instability	1.00
Gamma M2 for resistance of net sections	1.25

Material		
<i>*Student version* *Student version* *Student version* *</i>		
Yield strength f <sub>y</sub>	275.0	MPa
Ultimate strength f <sub>u</sub>	430.0	MPa
Fabrication	Rolled	

...:SECTION CHECK:...:

The critical check is on position 0.000 m

Internal forces	Calculated	Unit
<i>*Student version* *Student version* *Student version* *</i>		
N <sub>Ed</sub>	-123.42	kN
V <sub>y,Ed</sub>	0.19	kN
V <sub>z,Ed</sub>	8.35	kN
T <sub>Ed</sub>	0.00	kNm
M <sub>y,Ed</sub>	-28.00	kNm
M <sub>z,Ed</sub>	-0.70	kNm

**Classification for cross-section design**

According to EN 1993-1-1 article 5.5.2

**Classification of Internal Compression parts**

According to EN 1993-1-1 Table 5.2 Sheet 1

Maximum width-to-thickness ratio	25.23
Class 1 Limit	44.44
Class 2 Limit	51.18
Class 3 Limit	68.63

=&gt; Internal Compression parts Class 1

**Classification of Outstand Flanges**

According to EN 1993-1-1 Table 5.2 Sheet 2

Maximum width-to-thickness ratio	10.64
Class 1 Limit	8.32
Class 2 Limit	9.24
Class 3 Limit	12.79

=&gt; Outstand Flanges Class 3

=&gt; Section classified as Class 3 for cross-section design

**Compression check**

According to EN 1993-1-1 article 6.2.4 and fomula (6.9)

A	6.0400e-03	m <sup>2</sup>
Nc,Rd	1661.00	kN
Unity check	0.07	-

**Bending moment check for My**

According to EN 1993-1-1 article 6.2.5 and fomula (6.12),(6.14)

W <sub>el,y,min</sub>	5.2100e-04	m <sup>3</sup>
M <sub>el,y,Rd</sub>	143.28	kNm
Unity check	0.20	-

**Bending moment check for Mz**

According to EN 1993-1-1 article 6.2.5 and fomula (6.12),(6.14)

W <sub>el,z,min</sub>	1.7300e-04	m <sup>3</sup>
M <sub>el,z,Rd</sub>	47.58	kNm
Unity check	0.01	-

**Shear check for Vy**

According to EN 1993-1-1 article 6.2.6 and fomula (6.17)

Eta	1.20	
Av	4.4987e-03	m <sup>2</sup>
V <sub>pl,y,Rd</sub>	714.27	kN
Unity check	0.00	-

**Shear check for Vz**

According to EN 1993-1-1 article 6.2.6 and fomula (6.17)

Eta	1.20	
Av	2.1565e-03	m <sup>2</sup>
V <sub>pl,z,Rd</sub>	342.39	kN
Unity check	0.02	-

**Torsion check**

According to EN 1993-1-1 article 6.2.7 and formula (6.23)

Tau,t,Ed	0.0	MPa
Tau,Rd	158.8	MPa
Unity check	0.00	-

**Note:** The unity check for torsion is lower than the limit value of 0.05. Therefore torsion is considered as insignificant and is ignored in the combined checks.

**Combined bending, axial force and shear force check**

According to EN 1993-1-1 article 6.2.9.2 and formula (6.42)

Normal stresses		
<i>*Student version* *Student version* *Student vers</i>		
Fibre	1	
Sigma,N,Ed	20.4	MPa
Sigma,My,Ed	53.7	MPa
Sigma,Mz,Ed	4.1	MPa
Sigma,tot,Ed	78.2	MPa
Unity check	0.28	-

The member satisfies the section check.

**...::STABILITY CHECK::...****Classification for member buckling design**

Decisive position for stability classification: 0.000 m

**Classification of Internal Compression parts**

According to EN 1993-1-1 Table 5.2 Sheet 1

Maximum width-to-thickness ratio	25.23
Class 1 Limit	44.44
Class 2 Limit	51.18
Class 3 Limit	68.63

=&gt; Internal Compression parts Class 1

**Classification of Outstand Flanges**

According to EN 1993-1-1 Table 5.2 Sheet 2

Maximum width-to-thickness ratio	10.64
Class 1 Limit	8.32
Class 2 Limit	9.24
Class 3 Limit	12.79

=&gt; Outstand Flanges Class 3

=&gt; Section classified as Class 3 for member buckling design

**Flexural Buckling check**

According to EN 1993-1-1 article 6.3.1.1 and formula (6.46)



Buckling parameters	yy	zz	
<i>*Student version* *Student version* *Student version* *Student version* *Student version*</i>			
Sway type	sway	non-sway	
System length L	8.000	8.000	m
Buckling factor k	1.36	0.71	
Buckling length L <sub>cr</sub>	10.866	5.654	m
Critical Euler load N <sub>cr</sub>	1025.26	1348.42	kN
Slenderness Lambda	110.50	96.35	
Relative slenderness Lambda,rel	1.27	1.11	
Limit slenderness Lambda,rel,0	0.20	0.20	
Buckling curve	b	c	
Imperfection Alpha	0.34	0.49	
Reduction factor Chi	0.44	0.48	
Buckling resistance N <sub>b</sub> ,R <sub>d</sub>	731.18	795.66	kN

Flexural Buckling verification		
<i>*Student version* *Student version* *Student version* *Student version* *Stu</i>		
Cross-section area A	6.0400e-03	m <sup>2</sup>
Buckling resistance N <sub>b</sub> ,R <sub>d</sub>	731.18	kN
Unity check	0.17	-

**Torsional(-Flexural) Buckling check**

According to EN 1993-1-1 article 6.3.1.1 and formula (6.46)

Torsional buckling length L <sub>cr</sub>	8.000	m
Elastic critical load N <sub>cr,T</sub>	2008.55	kN
Elastic critical load N <sub>cr,TF</sub>	1025.26	kN
Relative slenderness Lambda,rel,T	1.27	
Limit slenderness Lambda,rel,0	0.20	
Buckling curve	c	
Imperfection Alpha	0.49	
Reduction factor Chi	0.40	
Cross-section area A	6.0400e-03	m <sup>2</sup>
Buckling resistance N <sub>b</sub> ,R <sub>d</sub>	665.21	kN
Unity check	0.19	-

**Lateral Torsional Buckling check**

According to EN 1993-1-1 article 6.3.2.1 &amp; 6.3.2.2 and formula (6.54)

LTB parameters		
<i>*Student version* *Student version* *Student version* *Student version* *Student versic</i>		
Method for LTB curve	General case	
Cross-section elastic modulus W <sub>el,y</sub>	5.2100e-04	m <sup>3</sup>
Elastic critical moment M <sub>cr</sub>	393.06	kNm
Relative slenderness Lambda,rel,LT	0.60	
Limit slenderness Lambda,rel,LT,0	0.20	
LTB curve	a	
Imperfection Alpha,LT	0.21	
Reduction factor Chi,LT	0.89	
Design buckling resistance M <sub>b</sub> ,R <sub>d</sub>	127.31	kNm
Unity check	0.22	-

Mcr parameters		
<i>*Student version* *Student version* *Student version* *Student version* *Stud</i>		
LTB length L	8.000	m
Influence of load position	no influence	
Correction factor k	1.00	
Correction factor kw	1.00	
LTB moment factor C1	2.95	
LTB moment factor C2	0.18	
LTB moment factor C3	1.00	
Shear center distance d,z	0	mm
Distance of load application z,g	0	mm
Mono-symmetry constant beta,y	0	mm
Mono-symmetry constant z,j	0	mm

**Note:** C parameters are determined according to ECCS 119 2006 / Galea 2002.

#### Bending and axial compression check

According to EN 1993-1-1 article 6.3.3 and formula (6.61),(6.62)

Bending and axial compression check parameters		
<i>*Student version* *Student version* *Student version* *Student version* *Student version* *Student version* *Student v</i>		
Interaction method	alternative method 1	
Cross-section area A	6.0400e-03	m <sup>2</sup>
Cross-section elastic modulus Wel,y	5.2100e-04	m <sup>3</sup>
Cross-section elastic modulus Wel,z	1.7300e-04	m <sup>3</sup>
Design compression force N,Ed	123.42	kN
Design bending moment (maximum) My,Ed	-28.00	kNm
Design bending moment (maximum) Mz,Ed	0.81	kNm
Characteristic compression resistance N,Rk	1661.00	kN
Characteristic moment resistance My,Rk	143.28	kNm
Characteristic moment resistance Mz,Rk	47.58	kNm
Reduction factor Chi,y	0.44	
Reduction factor Chi,z	0.40	
Reduction factor Chi,LT	0.89	
Interaction factor k,yy	1.01	
Interaction factor k,yz	0.58	
Interaction factor k,zy	1.04	
Interaction factor k,zz	0.59	

Maximum moment My,Ed is derived from beam B297 position 0.000 m.

Maximum moment Mz,Ed is derived from beam B297 position 8.000 m.

Interaction method 1 parameters		
<i>*Student version* *Student version* *Student version* *Student version* *Student version* *Student version* *Student version*</i>		
Critical Euler load N <sub>cr,y</sub>	1025.26	kN
Critical Euler load N <sub>cr,z</sub>	1348.42	kN
Elastic critical load N <sub>cr,T</sub>	2008.55	kN
Cross-section elastic modulus W <sub>el,y</sub>	5.2100e-04	m <sup>3</sup>
Second moment of area I <sub>y</sub>	5.8400e-05	m <sup>4</sup>
Second moment of area I <sub>z</sub>	2.0800e-05	m <sup>4</sup>
Torsional constant I <sub>t</sub>	2.3000e-07	m <sup>4</sup>
Method for equivalent moment factor C <sub>my,0</sub>	Table A.2 Line 2 (General)	
Design bending moment (maximum) M <sub>y,Ed</sub>	-28.00	kNm
Maximum relative deflection delta <sub>z</sub>	2.2	mm
Equivalent moment factor C <sub>my,0</sub>	0.90	
Method for equivalent moment factor C <sub>mz,0</sub>	Table A.2 Line 1 (Linear)	
Ratio of end moments Psi <sub>z</sub>	-0.87	
Equivalent moment factor C <sub>mz,0</sub>	0.57	
Factor mu <sub>y</sub>	0.93	
Factor mu <sub>z</sub>	0.95	
Factor epsilon <sub>y</sub>	2.63	
Factor a <sub>LT</sub>	1.00	
Critical moment for uniform bending M <sub>cr,0</sub>	133.19	kNm
Relative slenderness Lambda <sub>rel,0</sub>	1.04	
Limit relative slenderness Lambda <sub>rel,0,lim</sub>	0.33	
Equivalent moment factor C <sub>my</sub>	0.96	
Equivalent moment factor C <sub>mz</sub>	0.57	
Equivalent moment factor C <sub>mLT</sub>	1.00	

Unity check (6.61) = 0.17 + 0.22 + 0.01 = 0.40 -

Unity check (6.62) = 0.19 + 0.23 + 0.01 = 0.42 -

### Shear Buckling check

According to EN 1993-1-5 article 5 & 7.1 and fomula (5.10) & (7.1)

Shear Buckling parameters		
<i>*Student version* *Student version* *Student version* *Student version*</i>		
Buckling field length a	8.000	m
Web	unstiffened	
Web height h <sub>w</sub>	206	mm
Web thickness t	7	mm
Material coefficient epsilon	0.92	
Shear correction factor Eta	1.20	

Shear Buckling verification	
<i>*Student version* *Student version* *Student version*</i>	
Web slenderness h <sub>w</sub> /t	31.69
Web slenderness limit	55.46

**Note:** The web slenderness is such that Shear Buckling effects may be ignored according to EN 1993-1-5 article 5.1(2).

The member satisfies the stability check.

#### 4.9 Dimenziniranje bočne podrožnice

Dimenzioniranje konstrukcijskih elemenata je provedena softwerom Scia Engineer 2016 pomoću modula Steel.

Uzdužna sila u bočnoj podrožnici (N)

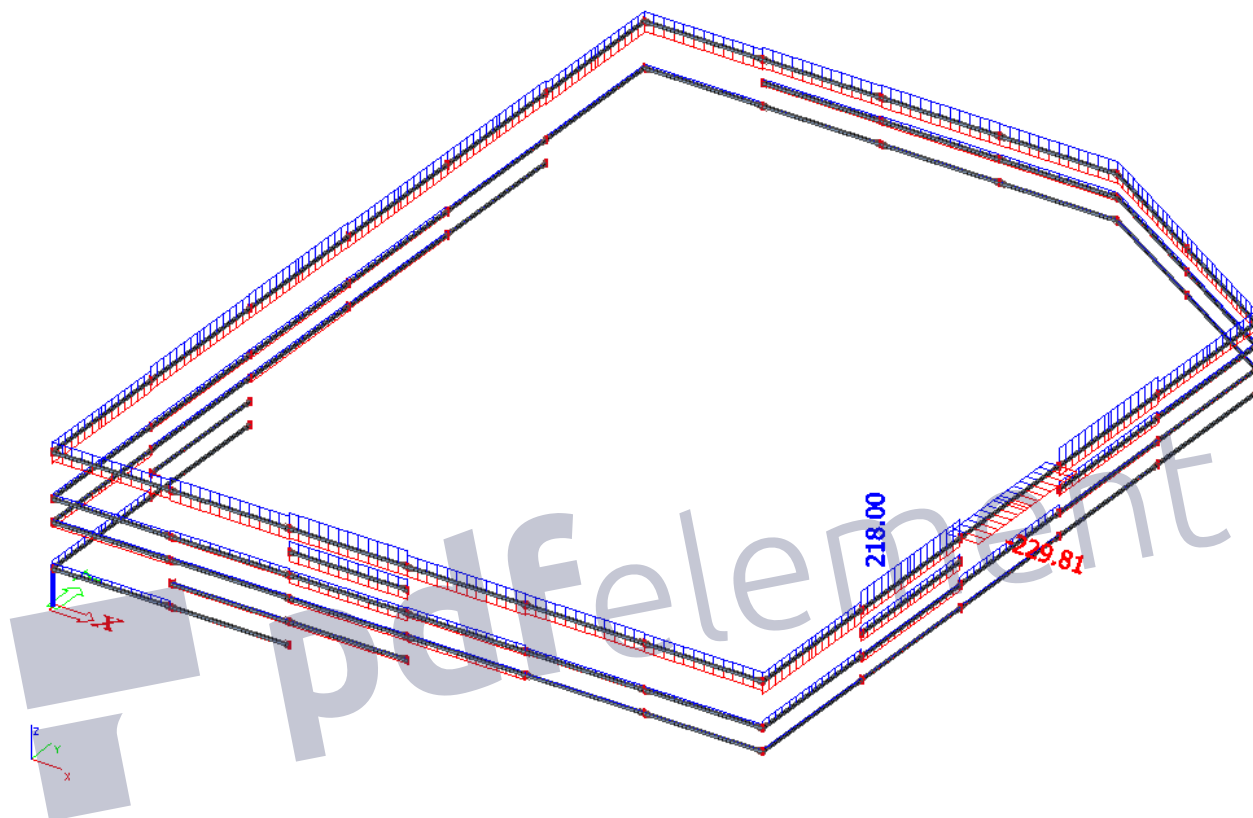

Slika 56: Vrijednosti uzdužne sile

Poprečna sila bočnoj podrožnici(Vz)

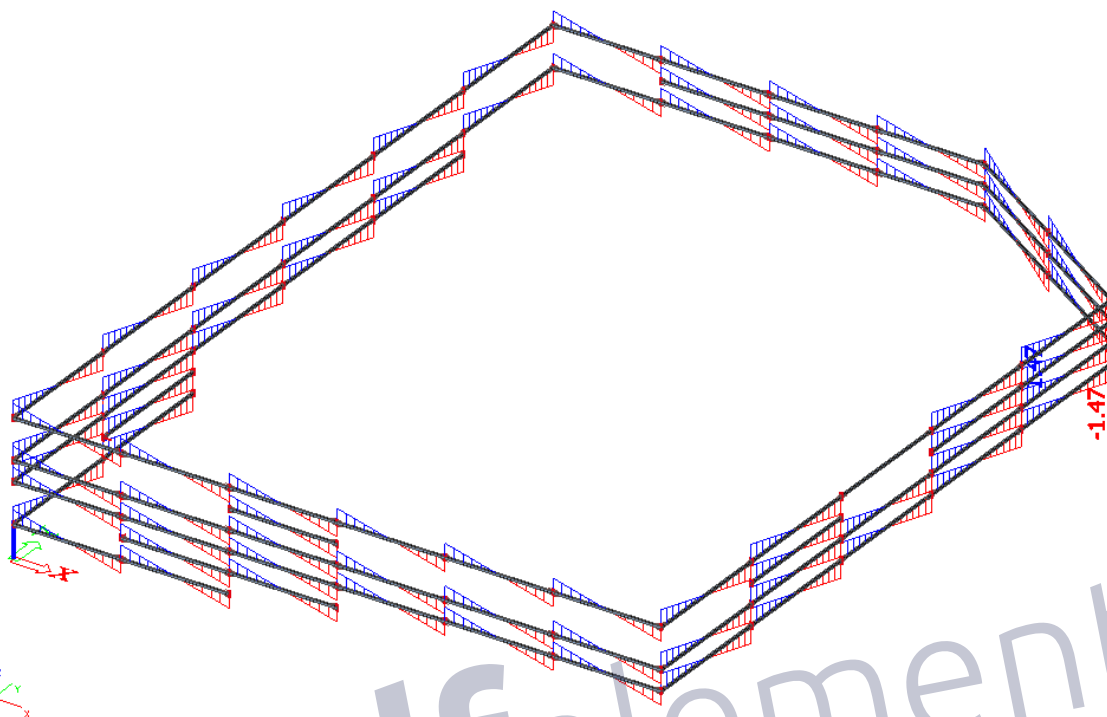

Slika 57: Vrijednosti poprečne sile

Moment savijanja u bočnoj podrožnici (My)

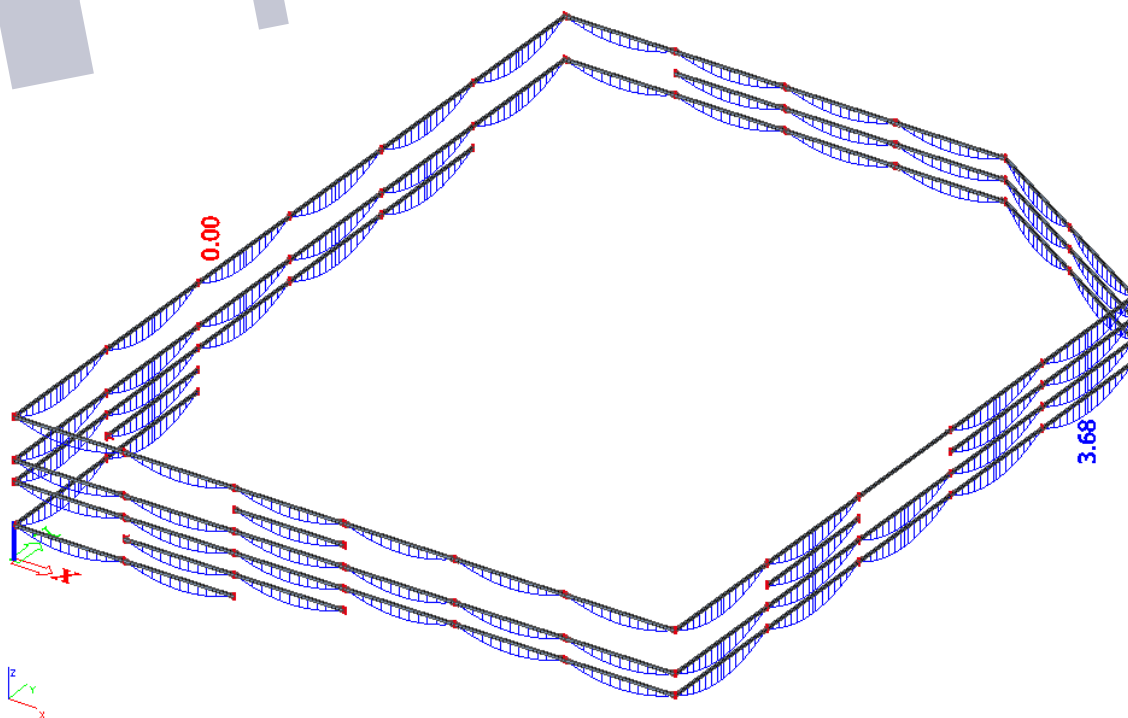

Slika 58: Vrijednosti momenta savijanja

Prikaz iskoristivosti elementa

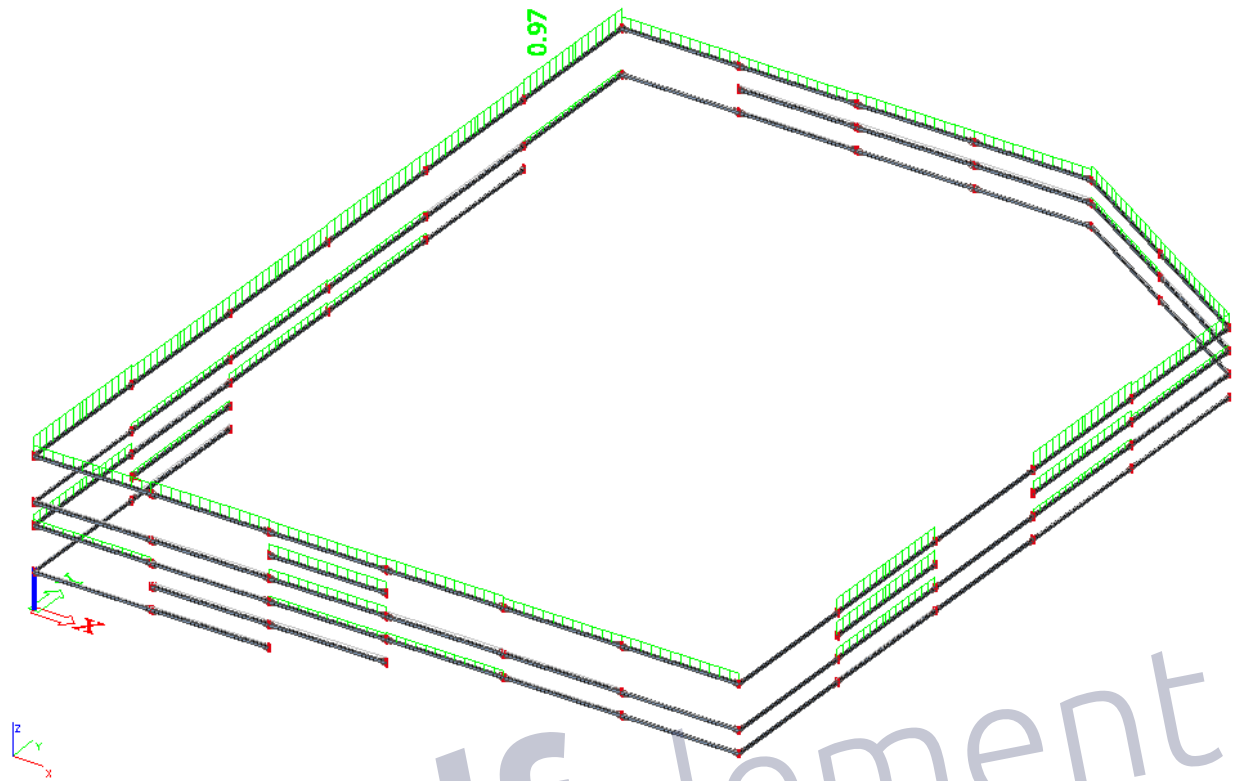

Slika 59: Prikaz iskoristivosti elementa

Poprečni presjek elementa

Name	CS6
Type	F150X5
Source description	Standard / GB 6728-2002
Item material	S 275
Fabrication	cold formed
Flexural buckling y-y	c
Flexural buckling z-z	c
Lateral torsional buckling	Default
Use 2D FEM analysis	x

A [m <sup>2</sup> ]	2.8356e-03	
A <sub>y, z</sub> [m <sup>2</sup> ]	1.4172e-03	1.4172e-03
I <sub>y, z</sub> [m <sup>4</sup> ]	9.8212e-06	9.8212e-06
I <sub>w</sub> [m <sup>6</sup> ], t [m <sup>4</sup> ]	3.1641e-08	1.5541e-05
W <sub>el y, z</sub> [m <sup>3</sup> ]	1.3095e-04	1.3095e-04
W <sub>pl y, z</sub> [m <sup>3</sup> ]	1.5298e-04	1.5298e-04
d <sub>y, z</sub> [mm]	0	0
c YUCS, ZUCS [mm]	75	75
α [deg]	0.00	
A <sub>L, D</sub> [m <sup>2</sup> /m]	5.8283e-01	1.1341e+00
M <sub>ply +, -</sub> [Nm]	4.20e+04	4.20e+04
M <sub>plz +, -</sub> [Nm]	4.20e+04	4.20e+04

Dimenzioniranje elementa je provedeno u softveru (modul Steel)

<b>Member B660</b>	<b>10.000 m</b>	<b>F150X5</b>	<b>S 275</b>	<b>GSN 10</b>	<b>0.97 -</b>
--------------------	-----------------	---------------	--------------	---------------	---------------

Note: EN 1993-1-3 article 1.1(3) specifies that this part does not apply to cold formed CHS and RHS sections. The default EN 1993-1-1 code check is executed instead of the EN 1993-1-3 code check.

Partial safety factors	
<i>*Student version* *Student version* *Student version* *Student version*</i>	
Gamma M0 for resistance of cross-sections	1.00
Gamma M1 for resistance to instability	1.00
Gamma M2 for resistance of net sections	1.25

Material		
<i>*Student version* *Student version* *Student version* *Student version*</i>		
Yield strength f <sub>y</sub>	275.0	MPa
Ultimate strength f <sub>u</sub>	430.0	MPa
Fabrication	Cold formed	

...:SECTION CHECK:...

The critical check is on position 0.000 m

Internal forces	Calculated	Unit
<i>*Student version* *Student version* *Student version* *Student version*</i>		
N,Ed	-134.77	kN
V <sub>y</sub> ,Ed	-0.02	kN
V <sub>z</sub> ,Ed	1.47	kN
T,Ed	0.03	kNm
M <sub>y</sub> ,Ed	0.00	kNm
M <sub>z</sub> ,Ed	0.09	kNm

**Classification for cross-section design**

According to EN 1993-1-1 article 5.5.2

**Classification of Internal Compression parts**

According to EN 1993-1-1 Table 5.2 Sheet 1

Maximum width-to-thickness ratio	27.00
Class 1 Limit	30.51
Class 2 Limit	35.13
Class 3 Limit	38.83

=&gt; Section classified as Class 1 for cross-section design

**Compression check**

According to EN 1993-1-1 article 6.2.4 and formula (6.9)

A	2.8356e-03	m <sup>2</sup>
N <sub>c,Rd</sub>	779.79	kN
Unity check	0.17	-

**Bending moment check for M<sub>z</sub>**

According to EN 1993-1-1 article 6.2.5 and formula (6.12),(6.13)

W <sub>pl,z</sub>	1.5298e-04	m <sup>3</sup>
M <sub>pl,z,Rd</sub>	42.07	kNm
Unity check	0.00	-

**Shear check for V<sub>y</sub>**

According to EN 1993-1-1 article 6.2.6 and formula (6.17)

Eta	1.20	
Av	1.4178e-03	m <sup>2</sup>
V <sub>pl,y,Rd</sub>	225.11	kN
Unity check	0.00	-

**Shear check for V<sub>z</sub>**

According to EN 1993-1-1 article 6.2.6 and formula (6.17)

Eta	1.20	
Av	1.4178e-03	m <sup>2</sup>
V <sub>pl,z,Rd</sub>	225.11	kN
Unity check	0.01	-

**Torsion check**

According to EN 1993-1-1 article 6.2.7 and formula (6.23)

Tau <sub>t,Ed</sub>	0.1	MPa
Tau <sub>t,Rd</sub>	158.8	MPa
Unity check	0.00	-

**Note:** The unity check for torsion is lower than the limit value of 0.05. Therefore torsion is considered as insignificant and is ignored in the combined checks.

**Combined bending, axial force and shear force check**

According to EN 1993-1-1 article 6.2.9.1 and formula (6.31)



MN,z,Rd	42.07	kNm
Unity check	0.00	-

**Note:** Since the shear forces are less than half the plastic shear resistances their effect on the moment resistances is neglected.

The member satisfies the section check.

...::**STABILITY CHECK**::...

**Classification for member buckling design**

Decisive position for stability classification: 0.000 m

**Classification of Internal Compression parts**

According to EN 1993-1-1 Table 5.2 Sheet 1

Maximum width-to-thickness ratio	27.00
Class 1 Limit	30.51
Class 2 Limit	35.13
Class 3 Limit	38.83

=> Section classified as Class 1 for member buckling design

**Flexural Buckling check**

According to EN 1993-1-1 article 6.3.1.1 and formula (6.46)

Buckling parameters	yy	zz	
<i>*Student version* *Student version* *Student version* *Student version* *Student version*</i>			
Sway type	sway	non-sway	
System length L	10.000	10.000	m
Buckling factor k	1.00	1.00	
Buckling length Lcr	10.000	10.000	m
Critical Euler load Ncr	203.56	203.56	kN
Slenderness Lambda	169.92	169.92	
Relative slenderness Lambda,rel	1.96	1.96	
Limit slenderness Lambda,rel,0	0.20	0.20	
Buckling curve	c	c	
Imperfection Alpha	0.49	0.49	
Reduction factor Chi	0.20	0.20	
Buckling resistance Nb,Rd	158.75	158.75	kN

Flexural Buckling verification		
<i>*Student version* *Student version* *Student version* *Student version* *Stu</i>		
Cross-section area A	2.8356e-03	m <sup>2</sup>
Buckling resistance Nb,Rd	158.75	kN
Unity check	0.85	-

**Torsional(-Flexural) Buckling check**

According to EN 1993-1-1 article 6.3.1.1 and formula (6.46)

**Note:** The cross-section concerns a RHS section which is not susceptible to Torsional(-Flexural) Buckling.

**Bending and axial compression check**

According to EN 1993-1-1 article 6.3.3 and formula (6.61),(6.62)

Bending and axial compression check parameters		
<i>*Student version* *Student version* *Student version* *Student version* *Student version* *Student version* *Student v</i>		
Interaction method	alternative method 1	
Cross-section area A	2.8356e-03	m <sup>2</sup>
Cross-section plastic modulus Wpl,y	1.5298e-04	m <sup>3</sup>
Cross-section plastic modulus Wpl,z	1.5298e-04	m <sup>3</sup>
Design compression force N,Ed	134.77	kN
Design bending moment (maximum) My,Ed	3.68	kNm
Design bending moment (maximum) Mz,Ed	0.09	kNm
Characteristic compression resistance N,Rk	779.79	kN
Characteristic moment resistance My,Rk	42.07	kNm
Characteristic moment resistance Mz,Rk	42.07	kNm
Reduction factor Chi,y	0.20	
Reduction factor Chi,z	0.20	
Reduction factor Chi,LT	1.00	
Interaction factor k,yy	1.38	
Interaction factor k,yz	0.31	
Interaction factor k,zy	1.38	
Interaction factor k,zz	0.48	

Maximum moment My,Ed is derived from beam B660 position 5.000 m.  
Maximum moment Mz,Ed is derived from beam B660 position 0.000 m.

Interaction method 1 parameters		
<i>*Student version* *Student version* *Student version* *Student version* *Student version* *Student version* *Student ver</i>		
Critical Euler load N,cr,y	203.56	kN
Critical Euler load N,cr,z	203.56	kN
Elastic critical load N,cr,T	181301.82	kN
Cross-section plastic modulus Wpl,y	1.5298e-04	m <sup>3</sup>
Cross-section elastic modulus Wel,y	1.3095e-04	m <sup>3</sup>
Cross-section plastic modulus Wpl,z	1.5298e-04	m <sup>3</sup>
Cross-section elastic modulus Wel,z	1.3095e-04	m <sup>3</sup>
Second moment of area Iy	9.8212e-06	m <sup>4</sup>
Second moment of area Iz	9.8212e-06	m <sup>4</sup>
Torsional constant It	1.5541e-05	m <sup>4</sup>
Method for equivalent moment factor C,my,0	Table A.2 Line 4 (Line load)	
Equivalent moment factor C,my,0	1.02	
Method for equivalent moment factor C,mz,0	Table A.2 Line 1 (Linear)	
Ratio of end moments Psi,z	-0.65	
Equivalent moment factor C,mz,0	0.42	
Factor mu,y	0.39	
Factor mu,z	0.39	
Factor epsilon,y	0.59	
Factor a,LT	0.00	
Critical moment for uniform bending Mcr,0	505.61	kNm
Relative slenderness Lambda,rel,0	0.29	
Limit relative slenderness Lambda,rel,0,lim	0.16	
Equivalent moment factor C,my	1.02	
Equivalent moment factor C,mz	0.42	
Equivalent moment factor C,mLT	1.00	
Factor b,LT	0.00	
Factor c,LT	0.00	

Factor d,LT	0.00	
Factor e,LT	0.00	
Factor w,y	1.17	
Factor w,z	1.17	
Factor n,pl	0.17	
Maximum relative slenderness Lambda,rel,max	1.96	
Factor C,yy	0.86	
Factor C,yz	0.93	
Factor C,zy	0.51	
Factor C,zz	1.02	

Unity check (6.61) =  $0.85 + 0.12 + 0.00 = 0.97$  -

Unity check (6.62) =  $0.85 + 0.12 + 0.00 = 0.97$  -

The member satisfies the stability check.

 pdfelement

#### 4.10 Dimenzioniranje sprega

Dimenzioniranje konstrukcijskih elemenata je provedena softverom Scia Engineer 2016 pomoću modula Steel.

Uzdužna sila u spregu (N)

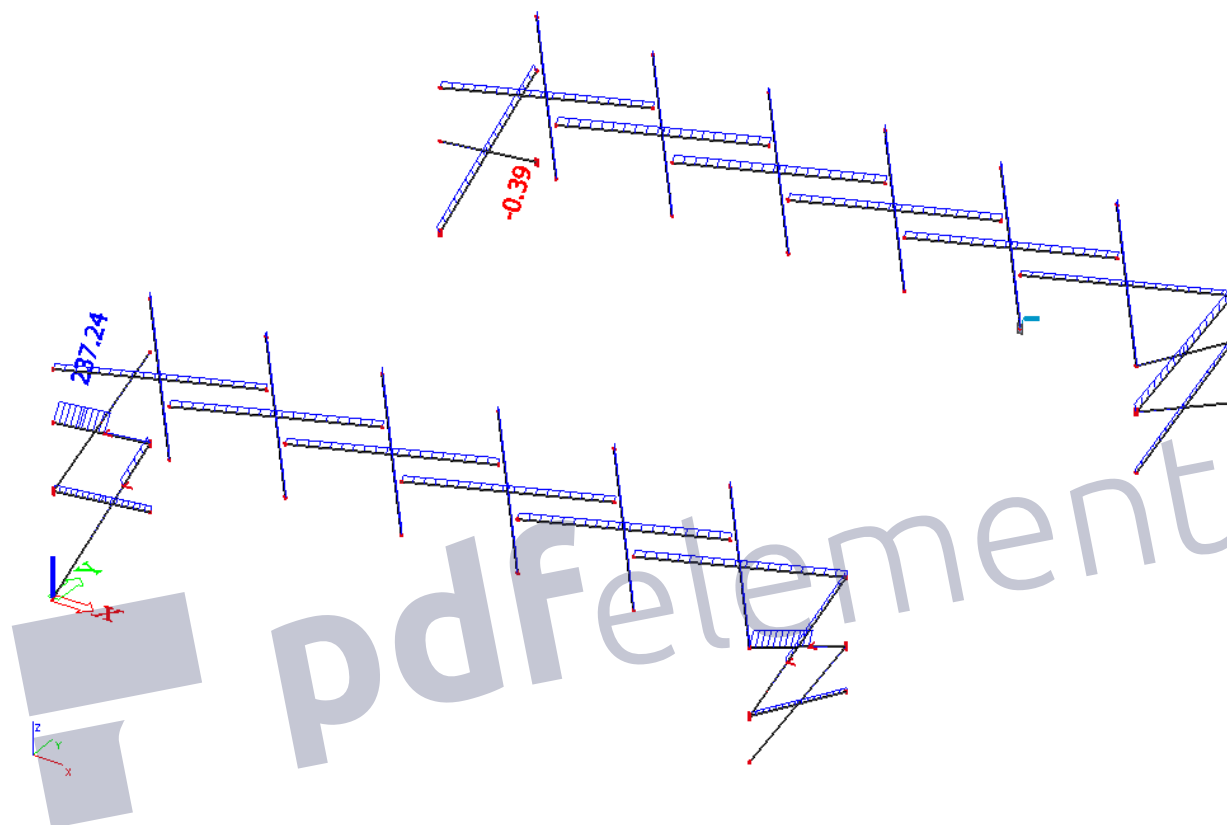

Slika 60: Vrijednosti uzdužne sile

## Poprečni presjek elementa

Name	CS39
Type	RD40
Source description	Stahl im Hochbau / 14.Auflage Band I / Teil 1
Item material	S 275
Fabrication	rolled
Flexural buckling y-y	c
Flexural buckling z-z	c
Lateral torsional buckling	Default
Use 2D FEM analysis	✓

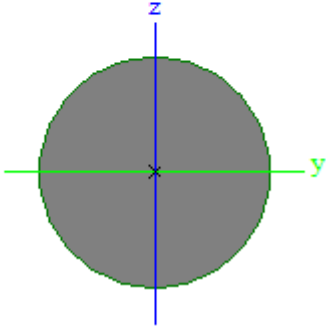

A [m <sup>2</sup> ]	1.2560e-03	
A <sub>y, z</sub> [m <sup>2</sup> ]	1.1317e-03	1.1317e-03
I <sub>y, z</sub> [m <sup>4</sup> ]	1.2303e-07	1.2303e-07
I <sub>w</sub> [m <sup>6</sup> ], I <sub>t</sub> [m <sup>4</sup> ]	2.0218e-34	2.5196e-07
W <sub>el y, z</sub> [m <sup>3</sup> ]	6.1515e-06	6.1515e-06
W <sub>pl y, z</sub> [m <sup>3</sup> ]	1.0499e-05	1.0499e-05
d <sub>y, z</sub> [mm]	0	0
c <sub>YUCS, ZUCS</sub> [mm]	20	20
α [deg]	0.00	
A <sub>L, D</sub> [m <sup>2</sup> /m]	1.2533e-01	1.2566e-01
M <sub>pl y, -</sub> [Nm]	2.93e+03	2.93e+03
M <sub>pl z, -</sub> [Nm]	2.93e+03	2.93e+03

## Dimenzioniranje elementa

$$N_{c,Rd} = N_{pl,Rd} = \frac{A \cdot f_y}{\gamma_{M_0}} = \frac{12,56 \cdot 27,5}{1,25} = 276,32(kN)$$

Uvjet nosivosti  $N_{c,Rd} \geq N_{Ed}$

$$276,32(kN) \geq 237,24(kN)$$

uvjet zadovoljen

#### 4.11 Dimenzioniranje grednog nosača međukatne konstrukcije

Dimenzioniranje konstrukcijskih elemenata je provedena softverom Scia Engineer 2016 pomoću modula Steel.

Uzdužna sila u gredi (N)

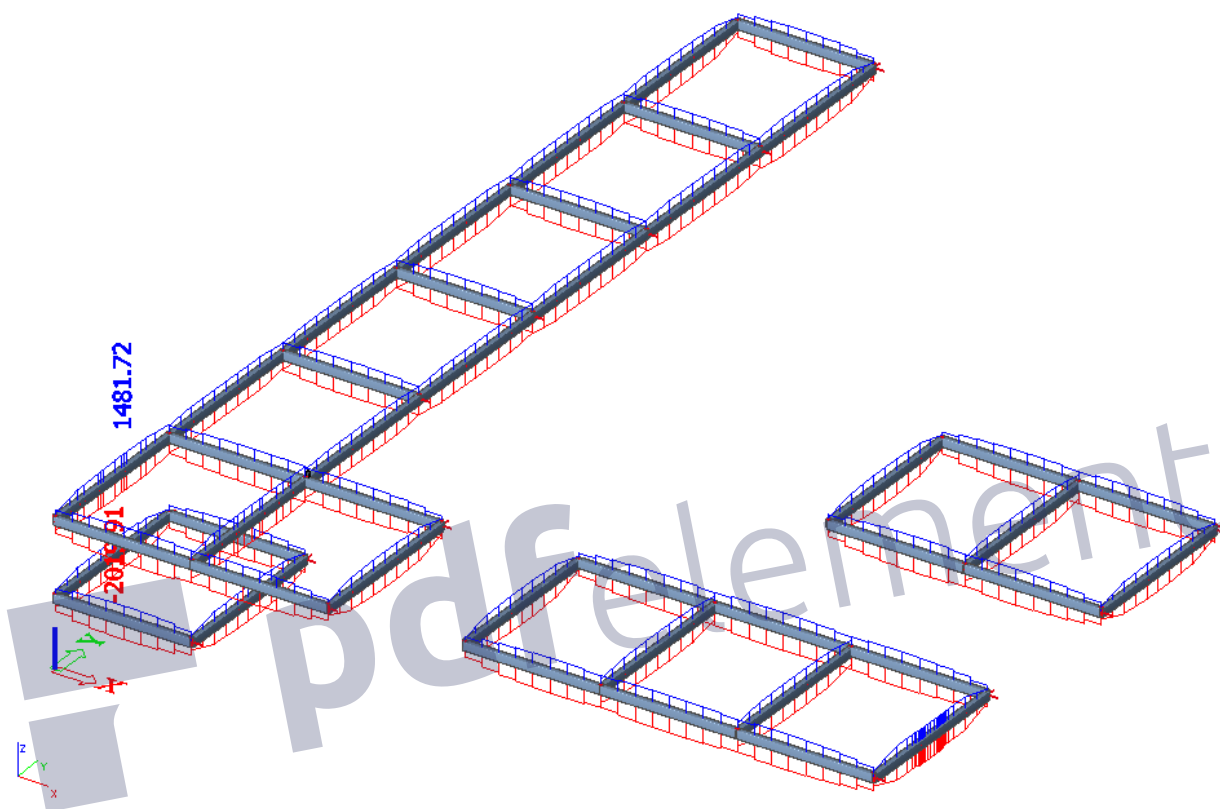

Slika 61: Vrijednosti uzdužne sile

Poprečna sila gredi(Vy)

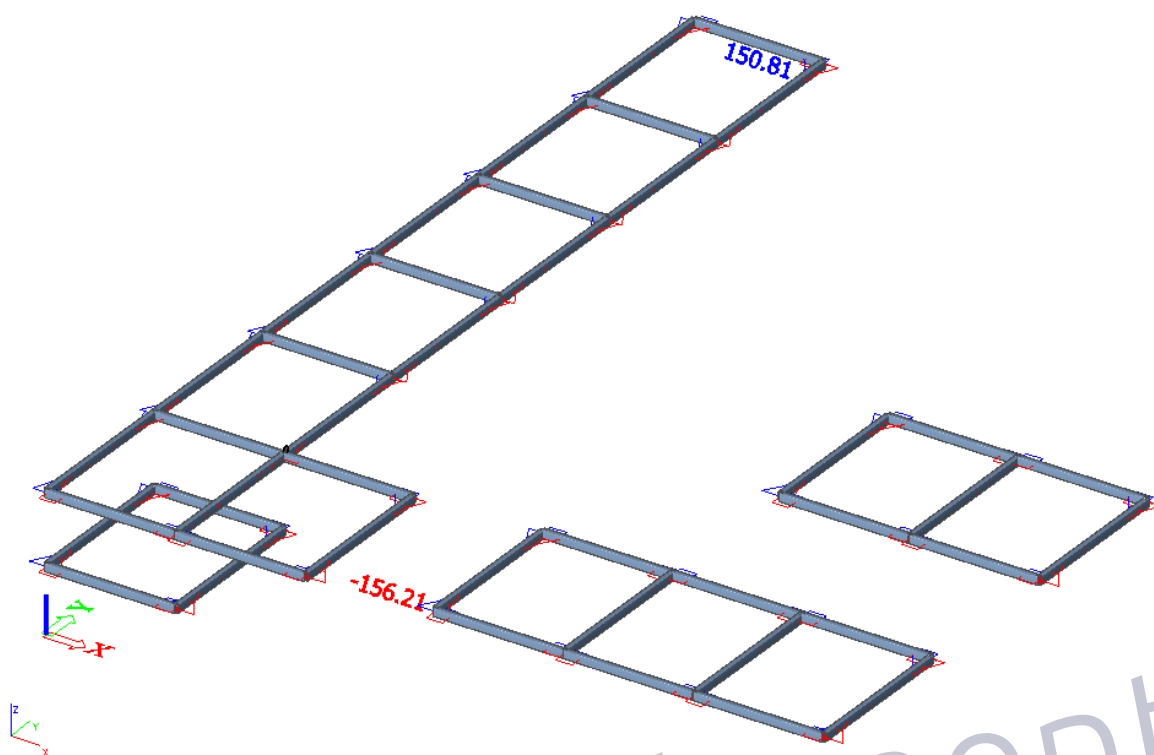

Slika 62: Vrijednosti poprečne sile  
Moment savijanja u bočnoj podrožnici (My)

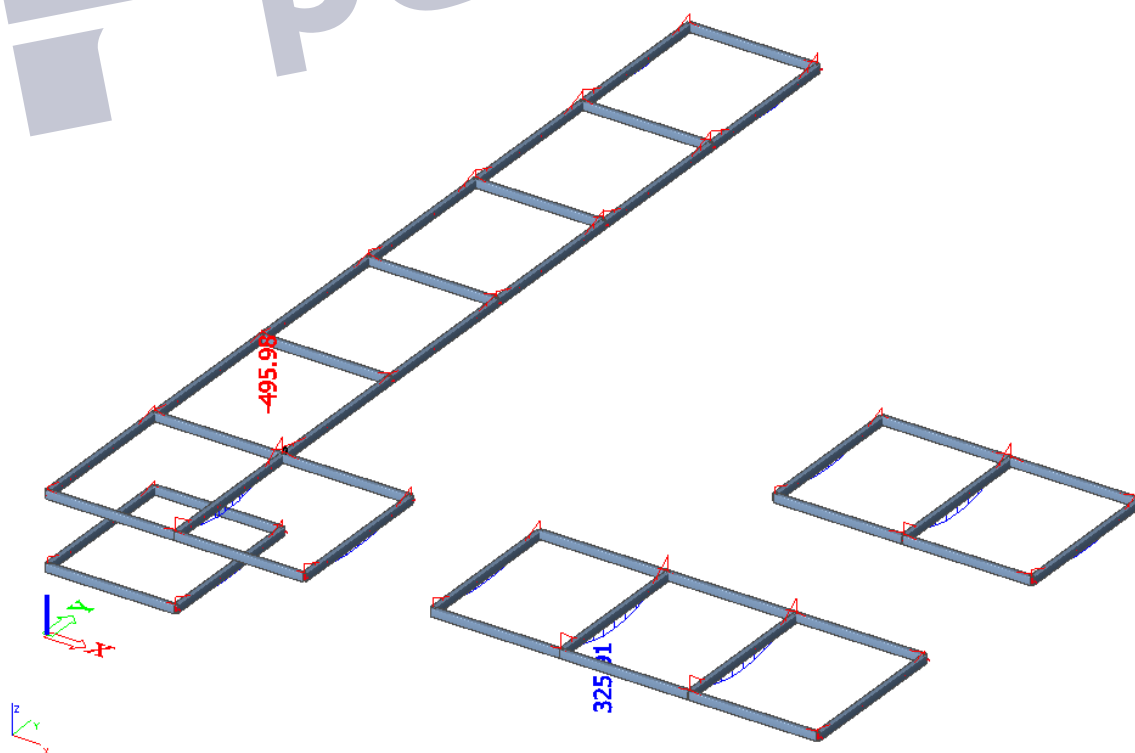

Slika 63: Vrijednosti momenta savijanja

Prikaz iskoristivosti elementa

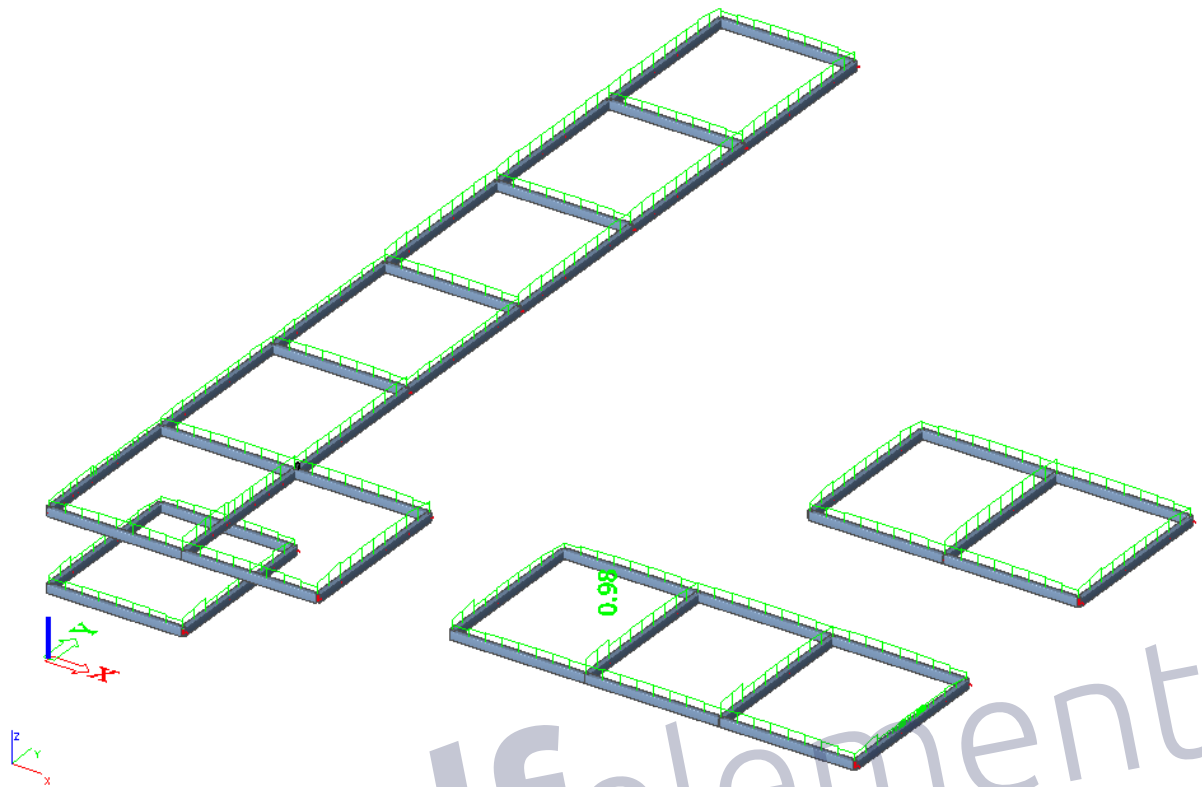

Slika 64: Prikaz iskoristivosti elementa

Poprečni presjek elementa

Name	CS37
Type	RHS
Detailed	500; 300; 13; 13; 10
Item material	S 275
Fabrication	rolled
Flexural buckling y-y	a
Flexural buckling z-z	a
Lateral torsional buckling	Default
Use 2D FEM analysis	x



A [m <sup>2</sup> ]	2.0064e-02	
A <sub>y, z</sub> [m <sup>2</sup> ]	7.5239e-03	1.2540e-02
I <sub>y, z</sub> [m <sup>4</sup> ]	6.8913e-04	3.1084e-04
I <sub>w</sub> [m <sup>6</sup> ], t [m <sup>4</sup> ]	9.7500e-06	6.5736e-04
W <sub>el y, z</sub> [m <sup>3</sup> ]	2.7565e-03	2.0723e-03
W <sub>pl y, z</sub> [m <sup>3</sup> ]	3.3437e-03	2.3435e-03
d <sub>y, z</sub> [mm]	0	0
c <sub>YUCS, ZUCS</sub> [mm]	150	250
α [deg]	0.00	
A <sub>L, D</sub> [m <sup>2</sup> /m]	1.5776e+00	3.0563e+00
M <sub>ply +, -</sub> [Nm]	9.20e+05	9.20e+05
M <sub>plz +, -</sub> [Nm]	6.44e+05	6.44e+05

Dimenzioniranje elementa je provedeno u softveru (modul Steel)

<b>Member B395</b>	<b>10.000 m</b>	<b>RHS (500; 300; 13; 13; 10)</b>	<b>S 275</b>	<b>GSN 11</b>	<b>0.98 -</b>
--------------------	-----------------	-----------------------------------	--------------	---------------	---------------

Partial safety factors	
<i>*Student version* *Student version* *Student version* *Student version*</i>	
Gamma M0 for resistance of cross-sections	1.00
Gamma M1 for resistance to instability	1.00
Gamma M2 for resistance of net sections	1.25

Material		
<i>*Student version* *Student version* *Student version*</i>		
Yield strength f <sub>y</sub>	275.0	MPa
Ultimate strength f <sub>u</sub>	430.0	MPa
Fabrication	Rolled	

...:SECTION CHECK:...:

The critical check is on position 2.000 m

Internal forces	Calculated	Unit
<i>*Student version* *Student version* *Student version*</i>		
N <sub>,Ed</sub>	-1815.31	kN
V <sub>y,Ed</sub>	1.92	kN
V <sub>z,Ed</sub>	88.66	kN
T <sub>,Ed</sub>	-4.30	kNm
M <sub>y,Ed</sub>	45.43	kNm
M <sub>z,Ed</sub>	0.31	kNm

**Classification for cross-section design**

According to EN 1993-1-1 article 5.5.2

**Classification of Internal Compression parts**

According to EN 1993-1-1 Table 5.2 Sheet 1

Maximum width-to-thickness ratio	35.46
Class 1 Limit	30.51
Class 2 Limit	35.13
Class 3 Limit	42.89

=&gt; Section classified as Class 3 for cross-section design

**Compression check**

According to EN 1993-1-1 article 6.2.4 and formula (6.9)

A	2.0064e-02	m <sup>2</sup>
N <sub>c,Rd</sub>	5517.51	kN
Unity check	0.33	-

**Bending moment check for M<sub>y</sub>**

According to EN 1993-1-1 article 6.2.5 and formula (6.12),(6.14)

W <sub>el,y,min</sub>	2.7565e-03	m <sup>3</sup>
M <sub>el,y,Rd</sub>	758.04	kNm
Unity check	0.06	-

**Bending moment check for M<sub>z</sub>**

According to EN 1993-1-1 article 6.2.5 and formula (6.12),(6.14)

W <sub>el,z,min</sub>	2.0723e-03	m <sup>3</sup>
M <sub>el,z,Rd</sub>	569.88	kNm
Unity check	0.00	-

**Shear check for V<sub>y</sub>**

According to EN 1993-1-1 article 6.2.6 and formula (6.17)

Eta	1.20	
A <sub>v</sub>	7.5239e-03	m <sup>2</sup>
V <sub>pl,y,Rd</sub>	1194.58	kN
Unity check	0.00	-

**Shear check for V<sub>z</sub>**

According to EN 1993-1-1 article 6.2.6 and formula (6.17)

Eta	1.20	
A <sub>v</sub>	1.2540e-02	m <sup>2</sup>
V <sub>pl,z,Rd</sub>	1990.96	kN
Unity check	0.04	-

**Torsion check**

According to EN 1993-1-1 article 6.2.7 and formula (6.23)

Tau <sub>t,Ed</sub>	1.2	MPa
Tau <sub>Rd</sub>	158.8	MPa
Unity check	0.01	-

**Note:** The unity check for torsion is lower than the limit value of 0.05. Therefore torsion is considered as insignificant and is ignored in the combined checks.

**Combined bending, axial force and shear force check**

According to EN 1993-1-1 article 6.2.9.2 and formula (6.42)

Normal stresses		
<i>*Student version* *Student version* *Student version*</i>		
Fibre	9	
Sigma,N,Ed	90.5	MPa
Sigma,My,Ed	16.5	MPa
Sigma,Mz,Ed	0.1	MPa
Sigma,tot,Ed	107.1	MPa
Unity check	0.39	-

The member satisfies the section check.

...::**STABILITY CHECK**::...

**Classification for member buckling design**

Decisive position for stability classification: 1.000 m

**Classification of Internal Compression parts**

According to EN 1993-1-1 Table 5.2 Sheet 1

Maximum width-to-thickness ratio	35.46
Class 1 Limit	30.51
Class 2 Limit	35.13
Class 3 Limit	56.13

=> Section classified as Class 3 for member buckling design

**Flexural Buckling check**

According to EN 1993-1-1 article 6.3.1.1 and formula (6.46)

Buckling parameters		YY	ZZ	
<i>*Student version* *Student version* *Student version* *Student version* *Student version* *Stu</i>				
Sway type	sway	non-sway		
System length L	2.000	2.000	m	
Buckling factor k	1.00	1.00		
Buckling length Lcr	2.000	2.000	m	
Critical Euler load Ncr	357075.36	161064.87	kN	
Slenderness Lambda	10.79	16.07		
Relative slenderness Lambda,rel	0.12	0.19		
Limit slenderness Lambda,rel,0	0.20	0.20		

**Note:** The slenderness or compression force is such that Flexural Buckling effects may be ignored according to EN 1993-1-1 article 6.3.1.2(4).

**Torsional(-Flexural) Buckling check**

According to EN 1993-1-1 article 6.3.1.1 and formula (6.46)

**Note:** The cross-section concerns a RHS section which is not susceptible to Torsional(-Flexural) Buckling.

**Lateral Torsional Buckling check**

According to EN 1993-1-1 article 6.3.2.1

**Note:** The cross-section concerns an RHS section with ' $h / b < 10 / \text{Lambda,rel,z}$ '.

This section is thus not susceptible to Lateral Torsional Buckling.

**Bending and axial compression check**

According to EN 1993-1-1 article 6.3.3 and formula (6.61),(6.62)

Bending and axial compression check parameters		
<i>*Student version*</i> <i>*Student version*</i> <i>*Student version*</i> <i>*Student version*</i> <i>*Student version*</i> <i>*Student version*</i> <i>*Student v</i>		
Interaction method	alternative method 1	
Cross-section area A	2.0064e-02	m <sup>2</sup>
Cross-section elastic modulus Wel,y	2.7565e-03	m <sup>3</sup>
Cross-section elastic modulus Wel,z	2.0723e-03	m <sup>3</sup>
Design compression force N,Ed	1815.31	kN
Design bending moment (maximum) My,Ed	-490.51	kNm
Design bending moment (maximum) Mz,Ed	1.77	kNm
Characteristic compression resistance N,Rk	5517.51	kN
Characteristic moment resistance My,Rk	758.04	kNm
Characteristic moment resistance Mz,Rk	569.88	kNm
Reduction factor Chi,y	1.00	
Reduction factor Chi,z	1.00	
Reduction factor Chi,LT	1.00	
Interaction factor k,y	1.00	
Interaction factor k,yz	1.00	
Interaction factor k,zy	1.00	
Interaction factor k,zz	1.00	

Maximum moment My,Ed is derived from beam B395 position 0.000 m.  
Maximum moment Mz,Ed is derived from beam B395 position 0.000 m.

Interaction method 1 parameters		
<i>*Student version*</i> <i>*Student version*</i> <i>*Student version*</i> <i>*Student version*</i> <i>*Student version*</i> <i>*Student version*</i> <i>*Student</i>		
Critical Euler load N,cr,y	357075.36	kN
Critical Euler load N,cr,z	161064.87	kN
Elastic critical load N,cr,T	1166664.15	kN
Cross-section elastic modulus Wel,y	2.7565e-03	m <sup>3</sup>
Second moment of area Iy	6.8913e-04	m <sup>4</sup>
Second moment of area Iz	3.1084e-04	m <sup>4</sup>
Torsional constant It	6.5736e-04	m <sup>4</sup>
Method for equivalent moment factor C,my,0	Table A.2 Line 2 (General)	
Design bending moment (maximum) My,Ed	-490.51	kNm
Maximum relative deflection delta,z	0.7	mm
Equivalent moment factor C,my,0	1.00	
Method for equivalent moment factor C,mz,0	Table A.2 Line 2 (General)	
Design bending moment (maximum) Mz,Ed	1.77	kNm
Maximum relative deflection delta,y	0.0	mm
Equivalent moment factor C,mz,0	0.99	
Factor mu,y	1.00	
Factor mu,z	1.00	
Factor epsilon,y	1.97	
Factor a,LT	0.05	
Critical moment for uniform bending Mcr,0	96774.80	kNm
Relative slenderness Lambda,rel,0	0.09	
Limit relative slenderness Lambda,rel,0,lim	0.28	
Equivalent moment factor C,my	1.00	
Equivalent moment factor C,mz	0.99	
Equivalent moment factor C,mLT	1.00	

Unity check (6.61) = 0.33 + 0.65 + 0.00 = 0.98 -  
Unity check (6.62) = 0.33 + 0.65 + 0.00 = 0.98 -  
The member satisfies the stability check.

## 4.12 Dimenzioniranje spregnute međukatne konstrukcije

Vertikalni progib međukatne konstrukcije

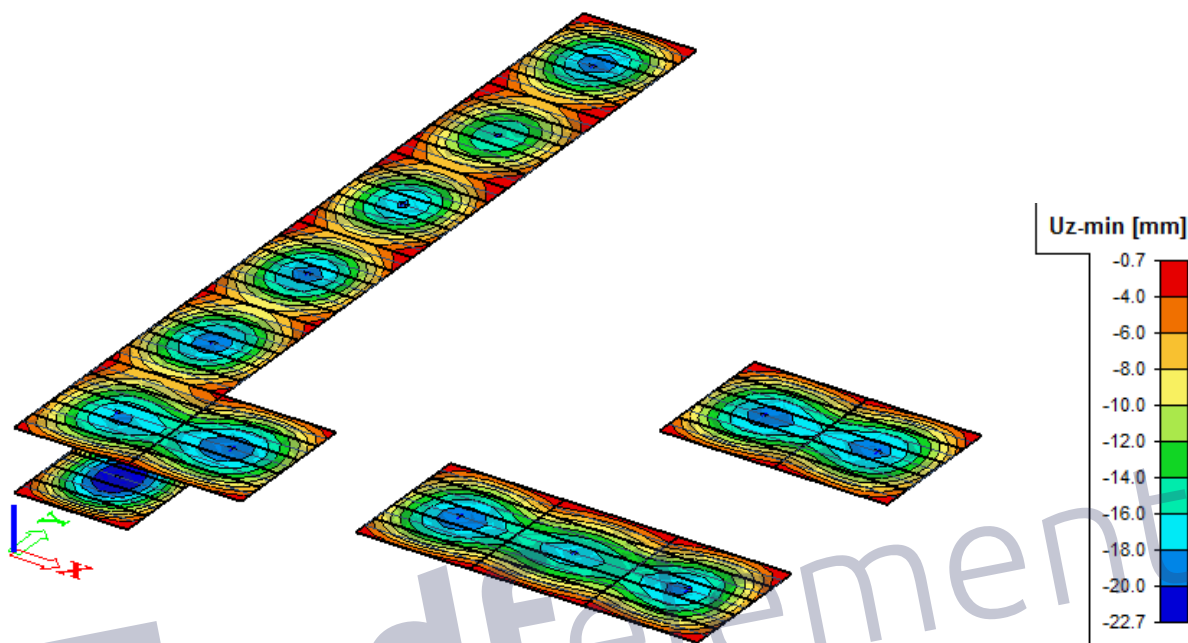

Slika 65: Vrijednosti vertikalnog progiba međukatne konstrukcije

Dopušteni vertikalni pomak(međukatna konstrukcija):

$$u_{dop} = \frac{l}{300} = \frac{8.000 \cdot 1000}{300} = 26.01 \text{ mm}$$

$$u_z = 22.7 \text{ mm} < u_{z,dop} = 26.01 \text{ mm} \quad \text{Zadovoljava}$$

Prikaz iskoristivosti presjeka na finalnu fazu

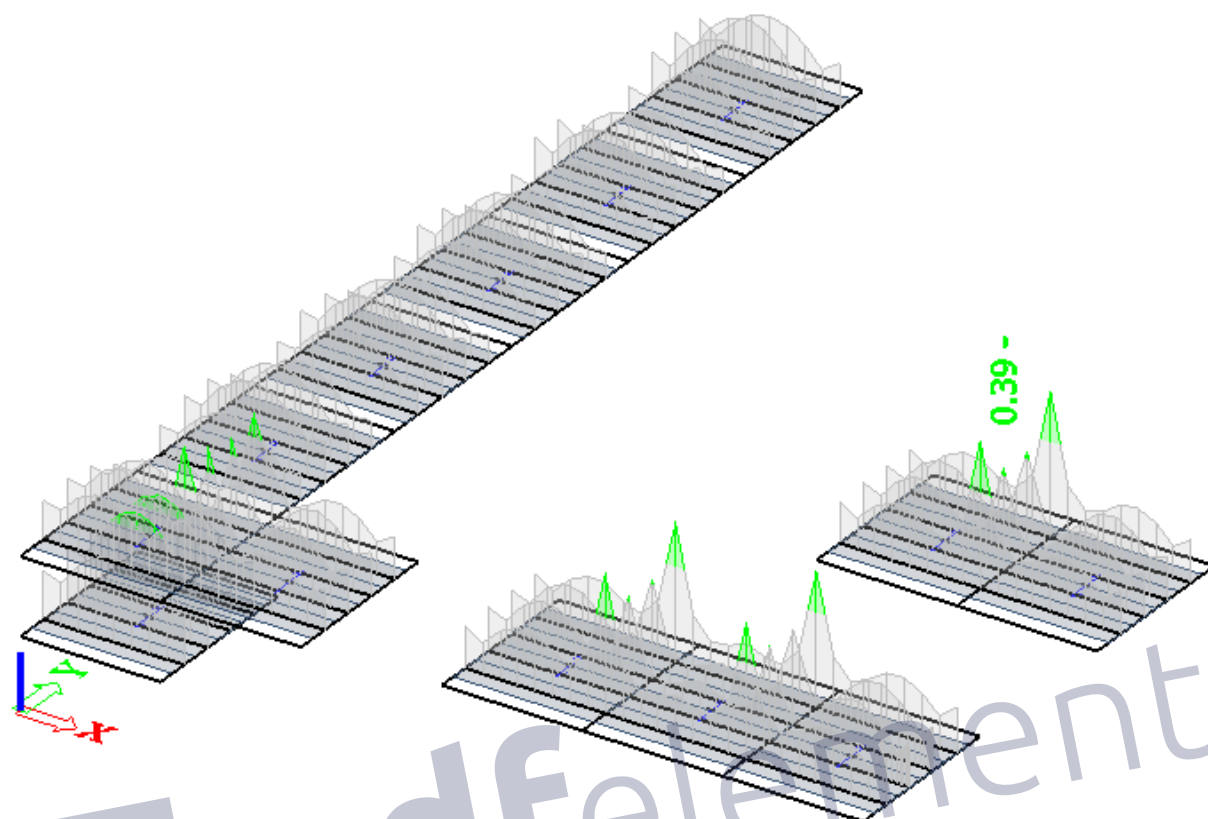

Slika 66: Prikaz iskoristivosti elementa

Dimenzioniranje elementa je provedeno u softveru (modul Composite)

SCIAENGINEER

### Composite Beam - Final stage

Linear calculation  
Combination: GSN final (spregnuta)  
Extreme 1D: Global  
Selection: All

#### Composite beam verification

for beam B890 at section 0 m, in accordance with EC EN 1994-1-1

##### 1. Geometry data

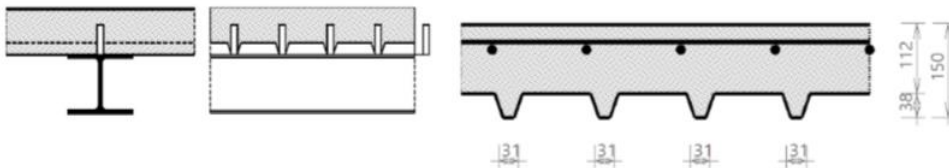

##### Continuous beam

Length of the current span	$L = 8 \text{ m}$
Length of previous span	$L_{\text{previous}} = 8 \text{ m}$
Distance to the slab edge at the left	$L_{\text{left}} = 2 \text{ m}$
Beam spacing at the right	$L_{\text{right}} = 2 \text{ m}$
Checked section	$d_x = 0 \text{ m}$

pdfelement

**2. Cross-section & materials****2.1 Steel section properties****2.1.1 Cross-section**

Cross-section	HEA200A
Height	$h_a = 186 \text{ mm}$
Width	$b = 200 \text{ mm}$
Web thickness	$t_w = 5.5 \text{ mm}$
Flange thickness	$t_f = 8 \text{ mm}$
Radius	$r = 18 \text{ mm}$
Area	$A_a = 4410 \text{ mm}^2$
Moment of inertia	$I_y = 29.4 \cdot 10^6 \text{ mm}^4$
Radius of gyration	$i_z = 49 \text{ mm}$
Plastic section modulus	$W_{ply} = 347083 \text{ mm}^3$

**2.1.2 Material**

Steel grade	S 275
Yield strength	$f_{yb} = 275 \text{ MPa}$
Ultimate strength	$f_{ub} = 430 \text{ MPa}$
E modulus	$E_b = 210000 \text{ MPa}$

**2.1.3 Cross-section classification**

$$\epsilon = \sqrt{\frac{235}{275}} = 0.924$$

(EN 1993-1-1 Art. 5.6 Table 5.2)

**2.1.3.1 Flange in compression**

$$c_f = \frac{b - t_w - 2 \cdot r}{2} = \frac{200 \text{ mm} - 5.5 \text{ mm} - 2 \cdot 18 \text{ mm}}{2} = 79.3 \text{ mm}$$

$$10 \cdot \epsilon < \frac{c_f}{t_f}$$

$$10 \cdot 0.924 < \frac{79.3 \text{ mm}}{8 \text{ mm}}$$

$$9.24 < 9.91$$

**2.1.3.2 Web in bending**

$$c_w = h_a - 2 \cdot t_f - 2 \cdot r = 186 \text{ mm} - 2 \cdot 8 \text{ mm} - 2 \cdot 18 \text{ mm} = 134 \text{ mm}$$

$$\alpha_{cl} = 0.5$$

$$c_w \leq \frac{36 \cdot \epsilon}{\alpha_{cl}}$$

$$\frac{134 \text{ mm}}{5.5 \text{ mm}} \leq \frac{36 \cdot 0.924}{0.5}$$

$$24.4 \leq 66.6$$

OK

Web classified as Class 1.



## 2.2 Concrete slab with profiled sheeting

### 2.2.1 Concrete slab

#### 2.2.1.1 Slab

Total height of the slab  $h_s = 150 \text{ mm}$

#### 2.2.1.2 Material

Concrete class C20/25  
 Characteristic strength  $f_{ck} = 20 \text{ MPa}$   
 E modulus  $E_{cm} = 30000 \text{ MPa}$

### 2.2.2 Profiled steel sheeting

Sheeting with ribs transverse to the supporting beams

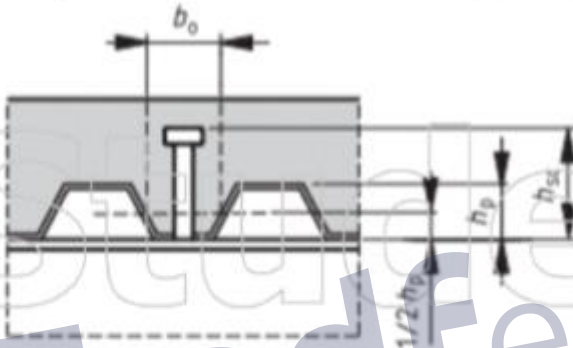

Name	Canam F 20
Depth of the ribs	$h_p = 38.1 \text{ mm}$
Height of full concrete	$h_c = 111.9 \text{ mm}$
Height of the re-entrant stiffener	$h_d = 0 \text{ mm}$
Spacing of the ribs	$b_s = 152.4 \text{ mm}$
Top width of the rib	$b_r = 108.5 \text{ mm}$
Bottom width of the rib	$b_b = 17.53 \text{ mm}$
Mean width of the ribs	$b_{0,rib} = 30.73 \text{ mm}$
Thickness of the sheeting	$t_d = 0.9093 \text{ mm}$

## 2.2.3 Shear connectors

### 2.2.3.1 Geometry

Name	SHC1
Diameter	$d_s = 20 \text{ mm}$
Nominal height	$h_{nom} = 100 \text{ mm}$
As-welded height	$h_{sc} = 95 \text{ mm}$
Number of connectors per row	$n_r = 1$

### 2.2.3.2 Material

Steel grade	S 235
Ultimate strength	$f_{us} = 360 \text{ MPa}$

## 2.2.4 Reinforcement

### 2.2.4.1 Geometry

Longitudinal bar diameter	$d_l = 16 \text{ mm}$
Longitudinal bar spacing	$s_l = 150 \text{ mm}$
Longitudinal bar cover	$c_l = 30 \text{ mm}$
Transverse bar diameter	$d_t = 16 \text{ mm}$
Transverse bar spacing	$s_t = 150 \text{ mm}$
Transverse bar cover	$c_t = 46 \text{ mm}$

### 2.2.4.2 Material

Material	B 500B
Characteristic yield strength	$f_{yk,r} = 500 \text{ MPa}$

## 3. Design values of loads

Load Name : GSN final(spregnuta)

Content of combination :  $1.35 \cdot Vlastitatezina + 1.35 \cdot dodatnostalno + 1.50 \cdot korisnoopterećenjemeđukatne$

Bending moment	$M_{Ed,comp} = -64.959 \text{ kNm}$
Shear force	$V_{Ed,comp} = 50.683 \text{ kN}$

## 4. Partial safety factors

Steel section	$\gamma_{M0} = 1$
	$\gamma_{M1} = 1$
Shear connectors	$\gamma_V = 1.25$
Concrete	$\gamma_C = 1.5$
Reinforcement	$\gamma_S = 1.15$

**5. ULS check of the Final stage****5.1 Shear connection****5.1.1 Design resistance of shear connectors****5.1.1.1 Shear connector in a solid slab**

$$\frac{h_{sc}}{d_s} > 4$$

$$4.75 > 4$$

$$\alpha = 1$$

$$f_{us} = \min(360; 450) \text{ MPa}$$

$$f_{us} = 360 \text{ MPa}$$

$$P_{Rd,solid,1} = \frac{0.8 \cdot f_{us} \cdot \left( \frac{\pi \cdot d_s^2}{4} \right)}{\gamma_v} = \frac{0.8 \cdot 360 \text{ MPa} \cdot \left( \frac{3.14 \cdot 20 \text{ mm}^2}{4} \right)}{1.25} = 72.4 \text{ kN}$$

$$P_{Rd,solid,2} = \frac{0.29 \cdot \alpha \cdot d_s^2 \cdot \sqrt{f_{ck} \cdot E_{cm}}}{\gamma_v} = \frac{0.29 \cdot 1 \cdot 20 \text{ mm}^2 \cdot \sqrt{20 \text{ MPa} \cdot 30000 \text{ MPa}}}{1.25} = 71.9 \text{ kN}$$

$$P_{Rd,solid} = \min(P_{Rd,solid,1}; P_{Rd,solid,2}) = \min(72.4 \text{ kN}; 71.9 \text{ kN}) = 71.9 \text{ kN}$$

**5.1.1.2 Shear connector in profiled sheeting**

Sheeting with ribs transverse to the supporting beams

$$k_t = \frac{0.7}{\sqrt{n_r}} \cdot \left( \frac{b_{0,rib}}{h_p} \right) \cdot \left( \frac{h_{sc}}{h_p} - 1 \right) = \frac{0.7}{\sqrt{1}} \cdot \left( \frac{30.7 \text{ mm}}{38.1 \text{ mm}} \right) \cdot \left( \frac{95 \text{ mm}}{38.1 \text{ mm}} - 1 \right) = 0.843$$

$$k_{t,max} = 0.85$$

$$k_t = \min(k_t; k_{t,max}) = \min(0.843; 0.85) = 0.843$$

$$P_{Rd} = k_t \cdot P_{Rd,solid} = 0.843 \cdot 71.9 \text{ kN} = 60.6 \text{ kN}$$

*Warning: The conditions given by EN 1994-1-1 Art.6.6.4.2 (3) are not fulfilled.*

## 5.1.2 Degree of shear connection

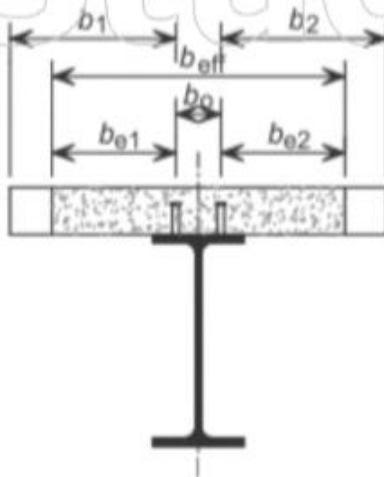
5.1.2.1 Determination of  $b_{eff}$  of the concrete flange and length  $L_e$ **The effective width at the internal support**

$$L_{e2} = 0.25 \cdot (L_1 + L_2) = 0.25 \cdot (8 \text{ m} + 8 \text{ m}) = 4 \text{ m}$$

**Left side of the beam**

$$b_1 = L_{\text{perp\_left}} - \frac{b_0}{2} = 2 \text{ m} - \frac{0 \text{ mm}}{2} = 2 \text{ m}$$

$$b_{e10} = \min\left(\frac{L_{e0}}{8}, b_1\right) = \min\left(\frac{0 \text{ m}}{8}, 2 \text{ m}\right) = 0 \text{ m}$$

$$b_{e11} = \min\left(\frac{L_{e1}}{8}, b_1\right) = \min\left(\frac{0 \text{ m}}{8}, 2 \text{ m}\right) = 0 \text{ m}$$

$$b_{e12} = \min\left(\frac{L_{e2}}{8}, b_1\right) = \min\left(\frac{4 \text{ m}}{8}, 2 \text{ m}\right) = 0.5 \text{ m}$$

**Right side of the beam**

$$b_2 = \frac{L_{\text{perp, right}}}{2} - \frac{b_0}{2} = \frac{2 \text{ m}}{2} - \frac{0 \text{ mm}}{2} = 1 \text{ m}$$

$$b_{e20} = \min\left(\frac{L_{e0}}{8}, b_2\right) = \min\left(\frac{0 \text{ m}}{8}, 1 \text{ m}\right) = 0 \text{ m}$$

$$b_{e21} = \min\left(\frac{L_{e1}}{8}, b_2\right) = \min\left(\frac{0 \text{ m}}{8}, 1 \text{ m}\right) = 0 \text{ m}$$

$$b_{e22} = \min\left(\frac{L_{e2}}{8}, b_2\right) = \min\left(\frac{4 \text{ m}}{8}, 1 \text{ m}\right) = 0.5 \text{ m}$$

**Calculation of  $b_{\text{eff},2}$** 

$$b_{\text{eff},2} = b_0 + b_{e12} + b_{e22} = 0 \text{ mm} + 0.5 \text{ m} + 0.5 \text{ m} = 1 \text{ m}$$

**Calculation of  $b_{\text{eff}}$** 

$$b_{\text{eff}} = b_{\text{eff},2} = 1 \text{ m}$$

**Determination of  $L_e$** 

$$L_e = L_{e2} = 4 \text{ m}$$

**5.1.2.2 Minimum degree of shear connection**

*Warning: Conditions given by EN 1994-1-1 Art. 6.6.1.2 (3) are not fulfilled.*

$$\eta_{\text{min,calc}} = 1 - \frac{355}{f_{yb}} \cdot (0.75 - 0.03 \cdot L_e)$$

$$\eta_{\text{min,calc}} = 1 - \frac{355}{275} \cdot (0.75 - 0.03 \cdot 4 \text{ m}) = 0.19$$

$$\eta_{\text{min}} = \max(\eta_{\text{min,calc}}; 0.4) = \max(0.19; 0.4) = 0.4$$

**5.1.2.3 Degree of shear connection present****5.1.2.3.1 Tension resistance of the reinforcement**

$$A_s = \frac{b_{\text{eff}}}{s_l} \cdot \left( \frac{d_l^2}{4} \right) \cdot \pi = \frac{1 \text{ m}}{150 \text{ mm}} \cdot \left( \frac{16 \text{ mm}^2}{4} \right) \cdot 3.14 = 1340 \text{ mm}^2$$

$$F_s = \frac{A_s \cdot f_{yk,r}}{\gamma_s} = \frac{1.34 \cdot 10^{-3} \cdot 500 \cdot 10^6}{1.15} = 583 \text{ kN}$$

**5.1.2.3.2 Tension resistance of the steel member**

$$N_{pl,a} = f_{yb} \cdot A_a = 275 \text{ MPa} \cdot 4410 \text{ mm}^2 = 1212.75 \text{ kN}$$

$$N_{c,f} = \min(F_s; N_{pl,a}) = \min(583 \text{ kN}; 1212.75 \text{ kN}) = 582.79 \text{ kN}$$

**5.1.2.3.3 Resistance of the shear connectors**

Number of full ribs available per length  $L_e$

$$n_{\text{rib}} = \frac{L_e}{b_s} = \frac{4 \text{ m}}{152 \text{ mm}}$$

$$n_{\text{rib}} = 26$$

$$l_s = b_s \cdot \text{trough} = 152 \text{ mm} \cdot 1 = 152 \text{ mm}$$

Number of shear studs available per length  $L_e/2$

$$n_{\text{sp}} = \frac{0.5 \cdot n_{\text{rib}} \cdot n_r}{\text{trough}} = \frac{0.5 \cdot 26 \cdot 1}{1} = 13$$

$$N_c = n_{\text{sp}} \cdot P_{Rd} = 13 \cdot 60618 = 788.04 \text{ kN}$$

$$\eta = \min\left(\frac{N_c}{N_{c,f}}, 1\right) = \min\left(\frac{788.04 \text{ kN}}{582.79 \text{ kN}}, 1\right) = 1$$

$$\eta \geq \eta_{\text{min}}$$

$$1 \geq 0.4$$

OK

The shear connection degree is adequate.

**5.2 Cross-sectional resistance of the composite beam****5.2.1 Shear buckling**

$$h_w = h_a - 2 \cdot t_f = 186 \text{ mm} - 2 \cdot 8 \text{ mm} = 170 \text{ mm}$$

$$\eta_{sb} = 1.2$$

$$\frac{h_w}{t_w} \leq \frac{72 \cdot \varepsilon}{\eta_{sb}}$$

$$\frac{170 \text{ mm}}{5.5 \text{ mm}} \leq \frac{72 \cdot 0.924}{1.2}$$

$$30.9 \leq 55.5$$

OK

The shear buckling resistance of the web does not need to be verified.

**5.2.2 Vertical shear**

The resistance to vertical shear should be taken as the resistance of the structural steel section.

$$A_v = A_a - 2 \cdot b \cdot t_f + (t_w + 2 \cdot r) \cdot t_f$$

$$= 4.41 \cdot 10^{-3} - 2 \cdot 0.2 \cdot 8 \cdot 10^{-3} + (5.5 \cdot 10^{-3} + 2 \cdot 0.018) \cdot 8 \cdot 10^{-3} = 1542 \text{ mm}^2$$

$$A_{v,min} = \eta_{sb} \cdot h_w \cdot t_w = 1.2 \cdot 0.17 \cdot 5.5 \cdot 10^{-3} = 1122 \text{ mm}^2$$

$$A_v \geq A_{v,min}$$

$$1542 \text{ mm}^2 \geq 1122 \text{ mm}^2$$

$$V_{pl,Rd} = \frac{A_v \cdot f_{yb}}{\sqrt{3} \cdot \gamma_{M0}} = \frac{1542 \text{ mm}^2 \cdot 275 \cdot 10^6}{\sqrt{3} \cdot 1} = 245 \text{ kN}$$

$$UC_{comp,V} = \frac{\text{abs}(V_{Ed,comp})}{V_{pl,Rd}} = \frac{\text{abs}(50.683 \text{ kN})}{245 \text{ kN}} = 0.21$$

The shear resistance of the section is adequate.

**5.2.3 Bending moment****5.2.3.1 Longitudinal reinforcement****5.2.3.1.1 Centre of composite section**For buildings not intended mainly for storage the effects of creep in concrete beams may be taken into account by using an effective E modulus  $E_{c,eff} = E_{cm} / 2$ .

$$E_{ceff} = \frac{E_{cm}}{2} = \frac{30000 \text{ MPa}}{2} = 15000 \text{ MPa}$$

$$n_E = \frac{E_b}{E_{ceff}} = \frac{210000 \text{ MPa}}{15000 \text{ MPa}} = 14$$

$$y_d = \frac{A_a \cdot \left(\frac{h_a}{2}\right) + \left(\frac{1}{n_E}\right) \cdot b_{eff} \cdot (h_c - h_d) \cdot \left(h_a + h_s - \frac{h_c - h_d}{2}\right)}{A_a + \left(\frac{1}{n_E}\right) \cdot b_{eff} \cdot (h_c - h_d)}$$

$$= \frac{4.41 \cdot 10^{-3} \cdot \left(\frac{0.186}{2}\right) + \left(\frac{1}{14}\right) \cdot 1 \cdot (0.112 - 0) \cdot \left(0.186 + 0.15 - \frac{0.112 - 0}{2}\right)}{4.41 \cdot 10^{-3} + \left(\frac{1}{14}\right) \cdot 1 \cdot (0.112 - 0)} = 214 \text{ mm}$$

**5.2.3.1.2 Degree of reinforcement**

$$A_s = \frac{b_{\text{eff}}}{s_l} \cdot \left( \frac{d_l^2}{4} \right) \cdot \pi = \frac{1 \text{ m}}{150 \text{ mm}} \cdot \left( \frac{16 \text{ mm}^2}{4} \right) \cdot 3.14 = 1340 \text{ mm}^2$$

$$A_c = b_{\text{eff}} \cdot (h_c - h_d) = 1 \cdot (0.112 - 0) = 111900 \text{ mm}^2$$

$$z_0 = \left( h_a + h_s - \frac{h_c - h_d}{2} \right) - y_d = \left( 0.186 + 0.15 - \frac{0.112 - 0}{2} \right) - 0.214 = 66.5 \text{ mm}$$

$$k_c = \min \left( \frac{1}{\left( 1 + \frac{h_c - h_d}{2 \cdot z_0} \right)} + 0.3; 1 \right) = \min \left( \frac{1}{\left( 1 + \frac{0.112 - 0}{2 \cdot 0.0665} \right)} + 0.3; 1 \right) = 0.843$$

$$\rho_s = \delta \cdot \left( \frac{f_{yb}}{235} \right) \cdot \left( \frac{f_{ctm}}{f_{yk,r}} \right) \cdot \sqrt{k_c} = 2 \cdot \left( \frac{275}{235} \right) \cdot \left( \frac{2.2 \cdot 10^6}{500 \cdot 10^6} \right) \cdot \sqrt{0.843} = 0.946 \%$$

$$A_s \geq \rho_s \cdot A_c$$

$$1340 \text{ mm}^2 \geq 9.46 \cdot 10^{-3} \cdot 111900 \text{ mm}^2$$

$$1340 \text{ mm}^2 \geq 1058 \text{ mm}^2 \quad \text{OK}$$

The longitudinal reinforcement of the section is adequate.

**5.2.3.2 Moment resistance****Moment resistance of a steel cross-section**

$$M_{pl,Rd,a} = \frac{W_{pl,y} \cdot f_{yb}}{\gamma_{M0}} = \frac{347083 \text{ mm}^3 \cdot 275 \text{ MPa}}{1} = 95.4 \text{ kNm}$$

**Influence of shear**

$$\frac{V_{pl,Rd}}{2} > \text{abs}(V_{Ed,comp})$$

$$\frac{245 \text{ kN}}{2} > 50.7 \text{ kN}$$

$$122 \text{ kN} > 50.7 \text{ kN} \quad \text{OK}$$

The influence of the vertical shear on the bending moment resistance may be neglected.

$$f_{yb,w} = f_{yb} = 275 \text{ MPa}$$

**Modified tension resistance of the steel member**

$$r = 0 \text{ mm}$$

$$A_a = 2 \cdot t_f \cdot b + t_w \cdot (h_a - 2 \cdot t_f) = 2 \cdot 8 \text{ mm} \cdot 200 \text{ mm} + 5.5 \text{ mm} \cdot (186 \text{ mm} - 2 \cdot 8 \text{ mm}) = 4135 \text{ mm}^2$$

$$N_{pl,a} = A_a \cdot f_{yb} = 4135 \text{ mm}^2 \cdot 275 \text{ MPa} = 1137.13 \text{ kN}$$

Note: Roundings of the steel cross section are neglected in bending resistance calculation.

$$N_{c,r} = \min(F_s; N_{pl,a}) = \min(583 \text{ kN}; 1137.13 \text{ kN}) = 582.79 \text{ kN}$$



**Negative bending moment resistance calculation**

The plastic neutral axis is located within the flange of the steel section.

$$N_{pl,a} - N_{a,f} = F_s + N_{a,f}$$

$$x = \frac{(N_{pl,a} - F_s)}{(2 \cdot b \cdot f_{yb})} = \frac{(1137.13 \text{ kN} - 583 \text{ kN})}{(2 \cdot 200 \text{ mm} \cdot 275 \text{ MPa})} = 5.04 \text{ mm}$$

Verification of the steel web classification.

$$\alpha_{cl} = 1$$

$$\frac{c_w}{t_w} \leq \frac{396 \cdot \epsilon}{13 \cdot \alpha_{cl} - 1}$$

$$\frac{134 \text{ mm}}{5.5 \text{ mm}} \leq \frac{396 \cdot 0.924}{13 \cdot 1 - 1}$$

$$24.4 \leq 30.5 \quad \text{OK}$$

Web classified as Class 1.

$$N_{at,f} = b \cdot x \cdot f_{yb} = 200 \text{ mm} \cdot 5.04 \text{ mm} \cdot 275 \text{ MPa} = 277.17 \text{ kN}$$

$$N_{a,c} = N_{pl,a} - N_{at,f} = 1137.13 \text{ kN} - 277.17 \text{ kN} = 859.96 \text{ kN}$$

Leverage arm of the compression part of the steel section calculated to the PNA.

pdfelement

$$h_{cs} = \frac{\left( b \cdot (t_f - x)^2 \cdot 0.5 + t_w \cdot (h_a - 2 \cdot t_f) \cdot \left( \frac{h_a}{2} - x \right) + t_f \cdot b \cdot \left( h_a - \frac{t_f}{2} - x \right) \right)}{b \cdot (t_f - x) + t_w \cdot (h_a - 2 \cdot t_f) + t_f \cdot b}$$

$$= \frac{\left( 200 \cdot (8 - 5.04)^2 \cdot 0.5 + 5.5 \cdot (186 - 2 \cdot 8) \cdot \left( \frac{186}{2} - 5.04 \right) + 8 \cdot 200 \cdot \left( 186 - \frac{8}{2} - 5.04 \right) \right)}{200 \cdot (8 - 5.04) + 5.5 \cdot (186 - 2 \cdot 8) + 8 \cdot 200}$$

$$h_{cs} = 117 \text{ mm}$$

$$h_l = x + h_s - c_1 + \frac{d_l}{2} = 5.04 \cdot 10^{-3} + 0.15 - 0.03 + \frac{0.016}{2} = 117 \text{ mm}$$

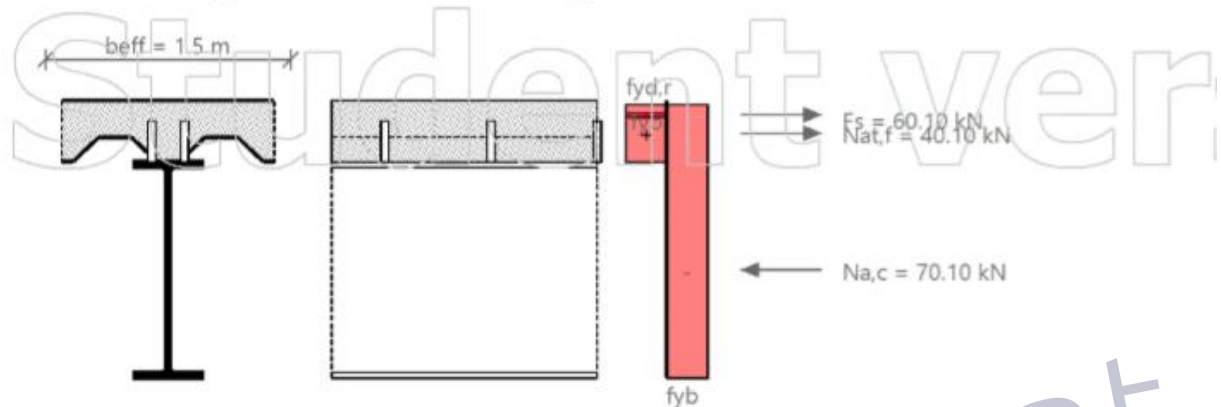

$$M_{pl,Rd} = F_s \cdot h_l + \frac{N_{at,f} \cdot x}{2} + N_{a,c} \cdot h_{cs} = 583 \cdot 117 + \frac{277.17 \cdot 5.04}{2} + 859.96 \cdot 117 = 170 \text{ kNm}$$

**Design moment resistance according to EN 1994-1-1 Art.6.2.1.2**

$$M_{Rd} = M_{pl,Rd} = 170 \text{ kNm}$$

$$UC_{comp\_M} = \frac{\text{abs}(M_{Ed,comp})}{M_{Rd}} = \frac{\text{abs}(-64.959 \text{ kNm})}{170 \text{ kNm}} = 0.38$$

The bending moment resistance of the section is adequate.

**5.3 LTB resistance**

$$F = \left(1 + \frac{t_w \cdot (h_a - t_f)}{4 \cdot b \cdot t_f}\right) \cdot \left(\frac{h_a - t_f}{t_w}\right)^{0.75} \cdot \left(\frac{t_f}{b}\right)^{0.25} = \left(1 + \frac{5.5 \cdot (186 - 8)}{4 \cdot 200 \cdot 8}\right) \cdot \left(\frac{186 - 8}{5.5}\right)^{0.75} \cdot \left(\frac{8}{200}\right)^{0.25} = 7$$

$$F_{lim} = 13.9$$

$$F \leq F_{lim}$$

$$7 \leq 13.9$$

OK

The cross-section is qualified for verification of LTB by the simplified method.

$$C_4 = 25$$

$$\lambda_{LT,rel} = 5 \cdot \left(1 + \frac{t_w \cdot (h_a - t_f)}{4 \cdot b \cdot t_f}\right) \cdot \left(\frac{h_a - t_f}{t_w}\right)^{0.75} \cdot \left(\frac{t_f}{b}\right)^{0.25} \cdot \left(\frac{f_{yb}}{E_b \cdot C_4}\right)^{0.5}$$

$$= 5 \cdot \left(1 + \frac{5.5 \cdot 10^{-3} \cdot (0.186 - 8 \cdot 10^{-3})}{4 \cdot 0.2 \cdot 8 \cdot 10^{-3}}\right) \cdot \left(\frac{0.186 - 8 \cdot 10^{-3}}{5.5 \cdot 10^{-3}}\right)^{0.75} \cdot \left(\frac{8 \cdot 10^{-3}}{0.2}\right)^{0.25} \cdot \left(\frac{275 \cdot 10^6}{210 \cdot 10^9 \cdot 25}\right)^{0.5} = 0.253$$

 $h_a/b < 2 \rightarrow$  Buckling curve 'a'

$$\alpha_{LT} = 0.21$$

$$\Phi_{LT} = 0.5 \cdot \left(1 + \alpha_{LT} \cdot (\lambda_{LT,rel} - 0.2) + \lambda_{LT,rel}^2\right) = 0.5 \cdot \left(1 + 0.21 \cdot (0.253 - 0.2) + 0.253^2\right) = 0.538$$

$$X_{LT} = \frac{1}{\Phi_{LT} + \sqrt{\Phi_{LT}^2 - \lambda_{LT,rel}^2}} = \frac{1}{0.538 + \sqrt{0.538^2 - 0.253^2}} = 0.988$$

$$X_{LT} = \min(X_{LT}; 1) = \min(0.988; 1) = 0.988$$

$$M_{b,Rd} = X_{LT} \cdot M_{Rd} = 0.988 \cdot 169628 = 167.629 \text{ kNm}$$

$$UC_{comp\_LTB} = \frac{\text{abs}(M_{Ed,comp})}{M_{b,Rd}} = \frac{\text{abs}(-64.959 \text{ kNm})}{167.629 \text{ kNm}} = 0.39$$

The later torsional buckling resistance of the section is adequate.

**5.4 Longitudinal shear****5.4.1 Transverse reinforcement**

Design shear flow

$$h_f = h_c = 112 \text{ mm}$$

$$v_{Ed} = \frac{n_r \cdot P_{Rd}}{l_s \cdot h_f} = \frac{1 \cdot 60.6 \text{ kN}}{152 \text{ mm} \cdot 112 \text{ mm}} = 3.55 \text{ MPa}$$

Transverse reinforcement

$$\frac{A_{st} \cdot f_{yk,r}}{\gamma_s \cdot s_f} \geq \frac{v_{Ed} \cdot h_f}{\cotg(\theta)}$$

$$A_t = A_{st}/s_f$$

$$A_t = \frac{v_{Ed} \cdot h_f}{\left(\frac{\cotg(\theta) \cdot f_{yk,r}}{\gamma_s}\right)} = \frac{3.55 \cdot 10^6 \cdot 0.112}{\left(\frac{\cotg(26.5) \cdot 500 \cdot 10^6}{1.15}\right)} = 456 \text{ mm}^2/\text{m}$$

$$A_{t,prov} = \frac{1}{s_t} \cdot \left(\frac{d_t^2}{4}\right) \cdot 3.14 = \frac{1}{0.15} \cdot \left(\frac{0.016^2}{4}\right) \cdot 3.14 = 1340 \text{ mm}^2/\text{m}$$

$$A_{t,prov} \geq A_t$$

$$1340 \text{ mm}^2/\text{m} \geq 456 \text{ mm}^2/\text{m} \quad \text{OK}$$

The transverse reinforcement of the section is adequate.

$$UC_{comp} = \max(0.21; 0.38; 0.39) = 0.39$$

## 5. DINAMIČKA ANALIZA

Računsko ubrzanje tla očitano je sa Seizmičke karte Republike Hrvatske i iznosi:  $a_g = 0,22$  g. Klasificiranjem vrste temeljnog tla utvrđeno je da se građevina nalazi na tlu klasa A koja se odnosi na stijenu ili drugu geološku formaciju s najviše 5 m slabijeg tla pri površini i krute naslage pijeska, šljunka ili prekonsolidirane gline. Za proračun seizmičkog opterećenja korištena je višemodalna spektralna analiza. Konstrukcija je proračunata u dva međusobno okomita horizontalna pravca. Odgovor konstrukcije dobiven je metodom spektra odgovora. Za dobivanje maksimalnog odgovora konstrukcije, tj. Kombinacije maksimalnih pojedinačni doprinosa svakog vlastitog oblika korištena je kombinacija SRSS.

- Seizmičko područje: IX zona
- Računsko ubrzanje tla:  $a_g = 0,22g$ ,  $g = 9,81 \text{ m/s}^2$
- Srednja kategorija duktilnosti DC“M“ (konstrukcije posebno otporne na potres, ne dolazi do krhkog loma pod cikličkim djelovanjem sila potresa u području plastičnih zglobova)
- Kategorija tla: A
- Faktor značaja:  $\gamma = 1.0$  (obične zgrade, stambene)

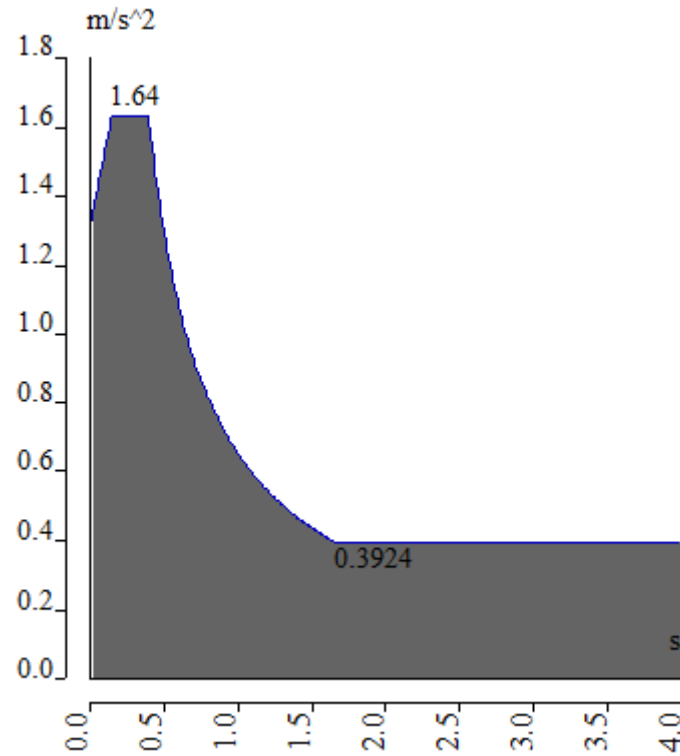

Slika 67: Ulazni projektni spektar odgovora

Modalna analiza

## Calculation protocol

### Solution of Free Vibration

Number of 2D elements	1190
Number of 1D elements	2463
Number of mesh nodes	1744
Number of equations	10464
Combination of mass groups	MC 1 CM1
Number of frequencies	50
Method	Lanczos
Bending theory	Mindlin
Type of analysis model	Standard
Start of calculation	18.04.2017 21:08
End of calculation	18.04.2017 21:08

### Sum of masses

[kg]	X	Y	Z
Combination of mass groups 1	880873.08	880873.08	880873.08

Modal participation factors

Mode	Omega [rad/s]	Period [s]	Freq. [Hz]	Wxi / Wxtot	Wyi / Wytot	Wzi / Wztot	Wxi_R / Wxtot_R	Wyi_R / Wytot_R	Wzi_R / Spectral
1	14.5435	0.4320	2.3147	0.7148	0.0031	0.0001	0.0000	0.0004	0.1072
2	16.9419	0.3709	2.6964	0.0075	0.6657	0.0000	0.0017	0.0001	0.1026
3	18.6545	0.3368	2.9690	0.0851	0.0004	0.0001	0.0001	0.0025	0.0834
4	20.5205	0.3062	3.2659	0.0011	0.1677	0.0001	0.0001	0.0006	0.3313
5	21.1259	0.2974	3.3623	0.0396	0.0048	0.0001	0.0005	0.0009	0.1347
6	25.7418	0.2441	4.0969	0.0037	0.0424	0.0000	0.0008	0.0001	0.0173
7	26.9903	0.2328	4.2956	0.0013	0.0063	0.0001	0.0001	0.0002	0.0025
8	27.4553	0.2289	4.3696	0.0003	0.0000	0.0000	0.0000	0.0000	0.0011
9	28.1197	0.2234	4.4754	0.0026	0.0052	0.0001	0.0003	0.0000	0.0030
10	29.6106	0.2122	4.7127	0.0002	0.0000	0.0000	0.0000	0.0000	0.0004
11	30.3391	0.2071	4.8286	0.0000	0.0000	0.1117	0.1046	0.0891	0.0000
12	30.7896	0.2041	4.9003	0.0002	0.0001	0.0000	0.0000	0.0001	0.0021
13	31.2646	0.2010	4.9759	0.0000	0.0000	0.0798	0.0011	0.1111	0.0000
14	31.8650	0.1972	5.0715	0.0086	0.0019	0.0012	0.0000	0.0025	0.0094
15	32.3437	0.1943	5.1477	0.0030	0.0001	0.0004	0.0003	0.0003	0.0008

16	32.5099	0.1933	5.1741	0.0000	0.0000	0.0624	0.0582	0.0249	0.0000
17	33.1425	0.1896	5.2748	0.0000	0.0000	0.0000	0.0000	0.0000	0.0000
18	33.4955	0.1876	5.3310	0.0039	0.0081	0.0005	0.0043	0.0004	0.0331
19	33.8465	0.1856	5.3868	0.0001	0.0004	0.0000	0.0002	0.0000	0.0004
20	34.2857	0.1833	5.4567	0.0003	0.0001	0.0009	0.0017	0.0005	0.0000
21	34.4164	0.1826	5.4775	0.0000	0.0020	0.0039	0.0074	0.0036	0.0035
22	34.9321	0.1799	5.5596	0.0012	0.0012	0.0000	0.0003	0.0007	0.0002
23	35.2071	0.1785	5.6034	0.0005	0.0000	0.0001	0.0001	0.0000	0.0004
24	36.1251	0.1739	5.7495	0.0220	0.0001	0.0011	0.0001	0.0015	0.0026
25	36.6668	0.1714	5.8357	0.0035	0.0000	0.0000	0.0000	0.0002	0.0002
26	36.7486	0.1710	5.8487	0.0007	0.0002	0.0000	0.0000	0.0000	0.0002
27	37.0014	0.1698	5.8890	0.0000	0.0001	0.0005	0.0314	0.0005	0.0002
28	37.5137	0.1675	5.9705	0.0002	0.0011	0.0001	0.0000	0.0015	0.0019
29	37.5728	0.1672	5.9799	0.0000	0.0000	0.0008	0.0007	0.0267	0.0000
30	37.8536	0.1660	6.0246	0.0003	0.0069	0.0000	0.0018	0.0000	0.0057
31	37.9347	0.1656	6.0375	0.0001	0.0001	0.0494	0.0410	0.0445	0.0000
32	38.1046	0.1649	6.0645	0.0091	0.0001	0.0002	0.0009	0.0013	0.0072
33	38.3346	0.1639	6.1011	0.0098	0.0001	0.0000	0.0008	0.0010	0.0091

34	38.7031	0.1623	6.1598	0.0001	0.0000	0.0001	0.0001	0.0000	0.0004
35	39.0479	0.1609	6.2147	0.0002	0.0000	0.0000	0.0001	0.0000	0.0001
36	39.2981	0.1599	6.2545	0.0045	0.0000	0.0005	0.0002	0.0001	0.0023
37	39.8052	0.1578	6.3352	0.0000	0.0000	0.0002	0.0001	0.0000	0.0000
38	39.9297	0.1574	6.3550	0.0000	0.0000	0.0005	0.0001	0.0000	0.0001
39	40.2416	0.1561	6.4046	0.0000	0.0000	0.0001	0.0000	0.0000	0.0001
40	40.3500	0.1557	6.4219	0.0000	0.0001	0.1090	0.1519	0.1025	0.0000
41	40.7913	0.1540	6.4921	0.0000	0.0000	0.0000	0.0000	0.0002	0.0000
42	41.1158	0.1528	6.5438	0.0004	0.0000	0.0003	0.0004	0.0003	0.0004
43	41.2550	0.1523	6.5659	0.0005	0.0006	0.0018	0.0000	0.0008	0.0004
44	41.5929	0.1511	6.6197	0.0000	0.0000	0.0034	0.0000	0.0005	0.0001
45	41.8578	0.1501	6.6619	0.0007	0.0033	0.0027	0.0009	0.0010	0.0000
46	42.1075	0.1492	6.7016	0.0000	0.0001	0.0037	0.0002	0.0000	0.0006

Mode	Omega [rad/s]	Period [s]	Freq. [Hz]	Wxi / Wxtot	Wyi / Wytot	Wzi / Wztot	Wxi_R / Wxtot_R	Wyi_R / Wytot_R	Wzi_R / Spectral
47	42.4888	0.1479	6.7623	0.0001	0.0000	0.0020	0.0011	0.0005	0.0000
48	42.7981	0.1468	6.8115	0.0000	0.0000	0.0020	0.0001	0.0000	0.0018
49	43.2021	0.1454	6.8758	0.0002	0.0001	0.0005	0.0009	0.0003	0.0016
50	43.3982	0.1448	6.9070	0.0027	0.0000	0.0000	0.0000	0.0002	0.0257
				0.9293	0.9225	0.4404	0.4147	0.4218	0.8944

Prvi vlastiti vektor

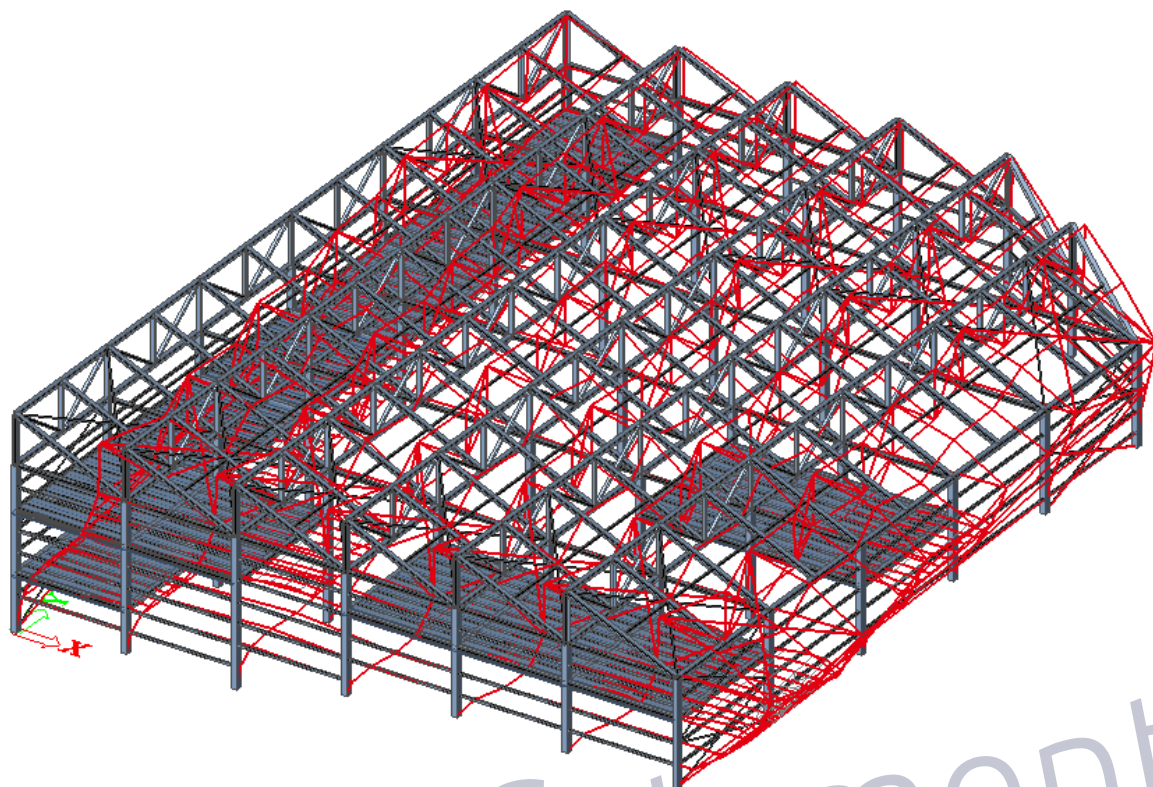

Slika 68: Aksonometrijski prikaz prvog vlastitog vektora

Drugi vlastiti vector

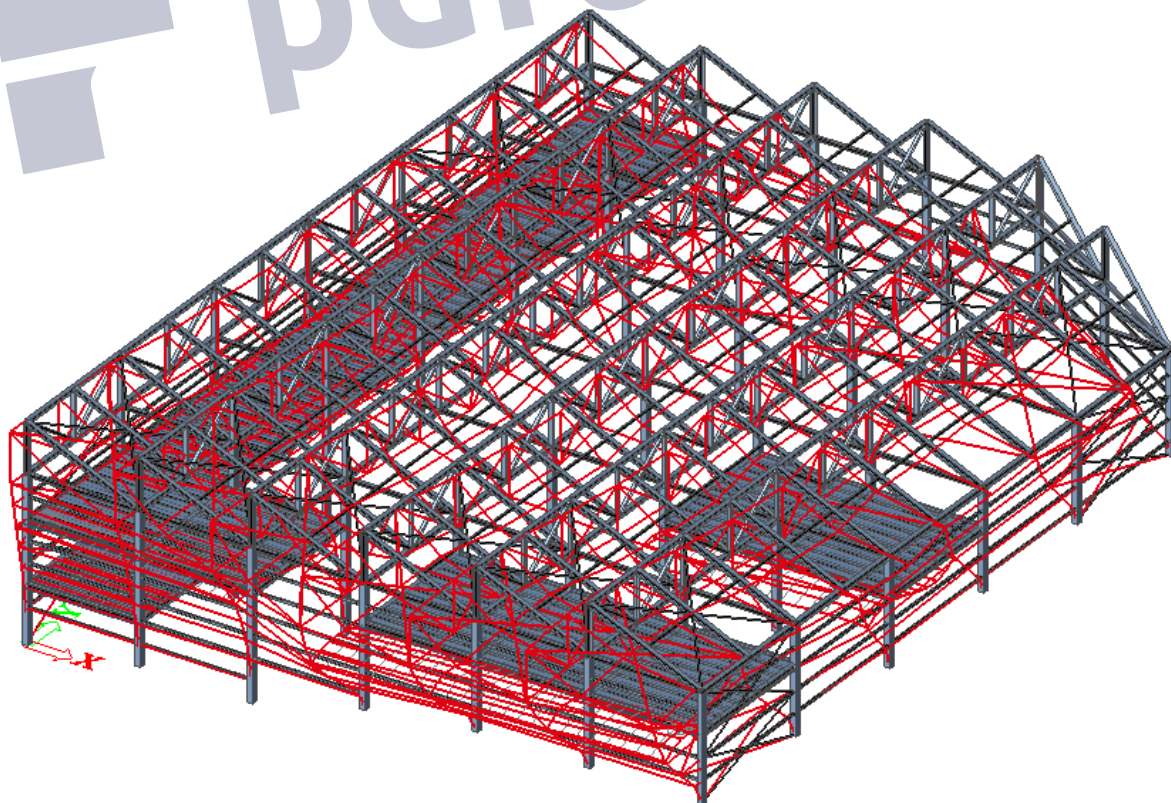

Slika 69: Aksonometrijski prikaz drugog vlastitog vektora

Treći vlastiti vector

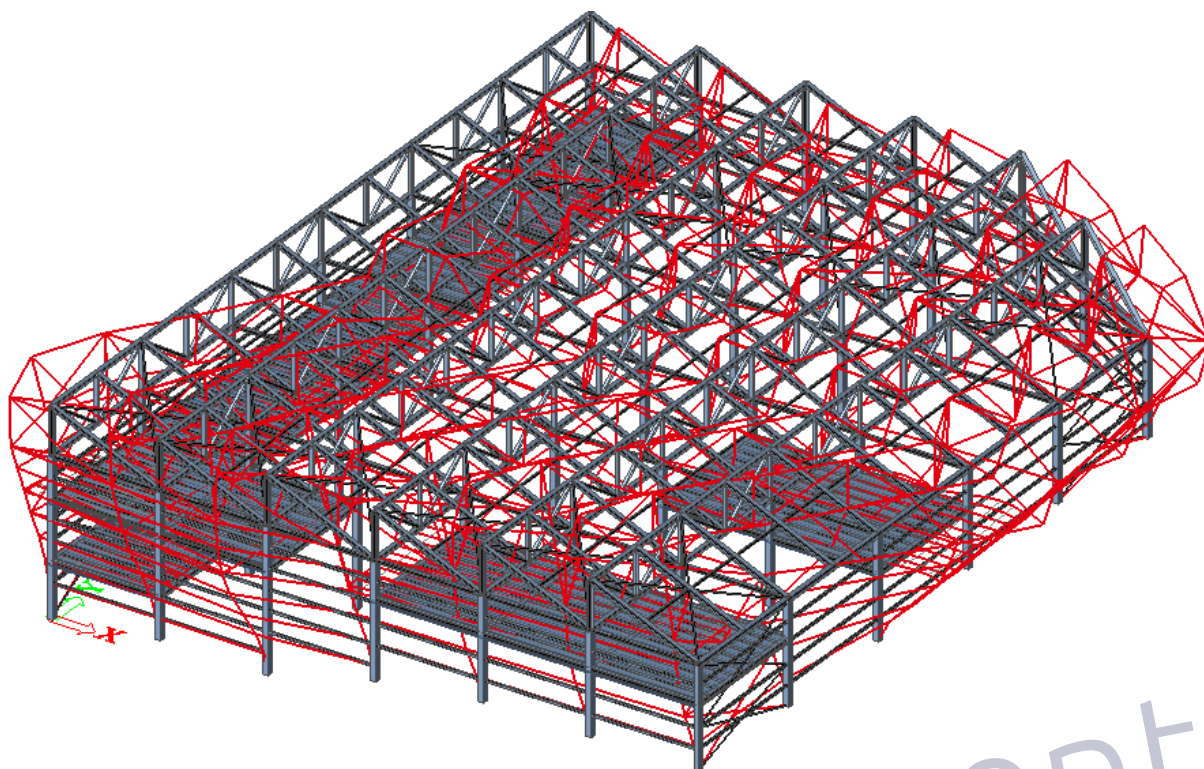

Slika 70: Aksonometrijski prikaz trećeg vlastitog vektora

Potresno opterećenje nije uzeto u obzir kod dimenzioniranja konstrukcije jer nema značajan utjecaj na konstrukciju. Mjerodavno opterećenje u ovom slučaju je vjetar .



## 6. ANALIZA STABILNOSTI KONSTRUKCIJE

Kombinacije opterećenja za analizu stabilnosti

### Stability combinations

Name	Load cases	Coeff. [-]
<i>*Student version* *Student version* *Student version* *Student version* *Student</i>		
S1	Vlastita tezina	1.00
	dodatno stalno	1.00
	korisno opterećenje međukatne	1.00
	snijeg 1	1.00
	vjetar 1 (odize)	1.00
	temperatura negativna	1.00
	trenjem po krovu	1.00
S2	Vlastita tezina	1.00
	dodatno stalno	1.00
	korisno opterećenje međukatne	1.00
	snijeg 1	1.00
	vjetar 2	1.00
	temperatura negativna	1.00
	trenjem po krovu	1.00
S3	Vlastita tezina	1.00
	dodatno stalno	1.00
	korisno opterećenje međukatne	1.00
	snijeg 2	1.00
	vjetar 2	1.00
	temperatura negativna	1.00
	trenjem po krovu	1.00
S4	Vlastita tezina	1.00
	dodatno stalno	1.00
	korisno opterećenje međukatne	1.00
	snijeg 2	1.00
	vjetar 1 (odize)	1.00
	temperatura negativna	1.00
	trenjem po krovu	1.00
S5	Vlastita tezina	1.00
	dodatno stalno	1.00
	vjetar 1 (odize)	1.00
	temperatura pozitivna	1.00
	trenjem po krovu	1.00
S6	Vlastita tezina	1.00
	dodatno stalno	1.00
	vjetar 2	1.00
	temperatura pozitivna	1.00
	trenjem po krovu	1.00

Prva kombinacija -koeficijent stabilnosti : 4.36

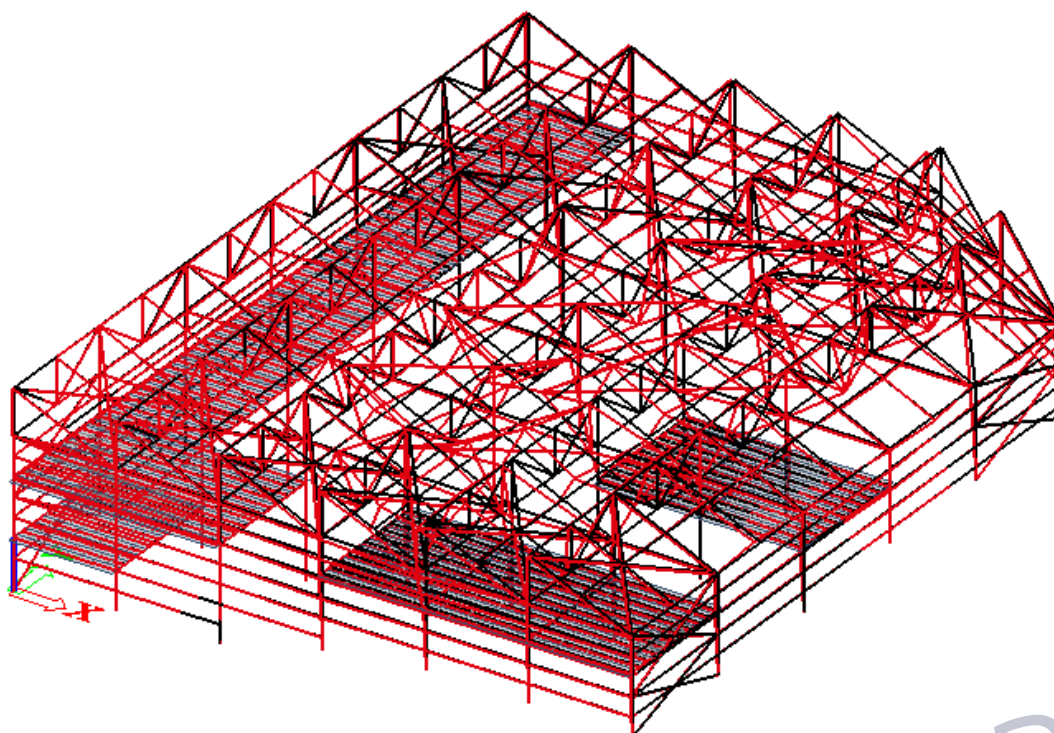

Slika 71: Prikaz deforamcije konstukcije

Druga kombinacija-koeficijent stabilnosti : 4,23

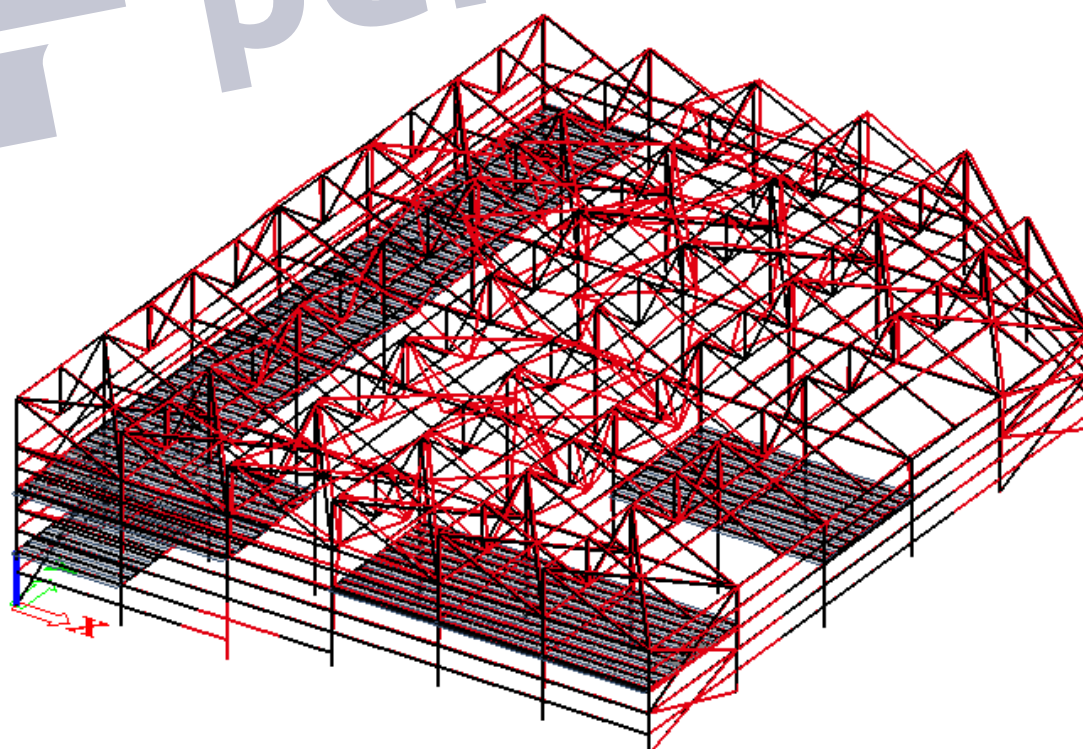

Slika 72: Prikaz deformacije konstukcije

Peta kombinacija-koeficijent stabilnosti : 21.6

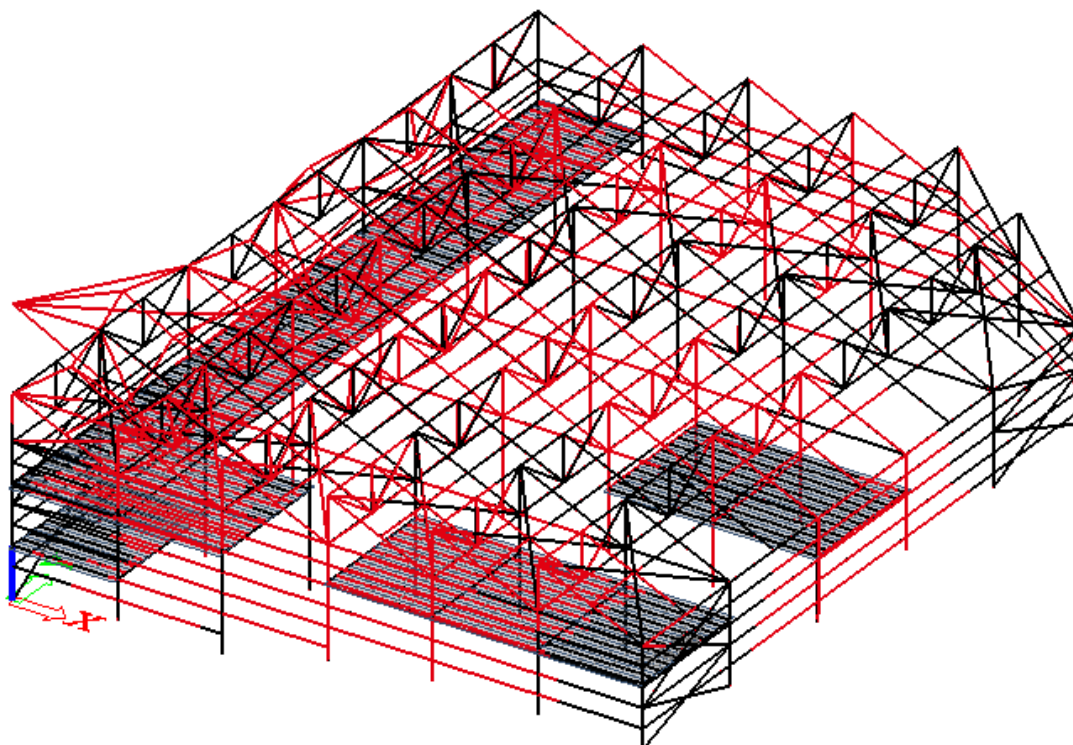

Slika 73: Prikaz deformacije konstrukcije  
Šesta kombinacija-koeffcijent stabilnosti: 22.76

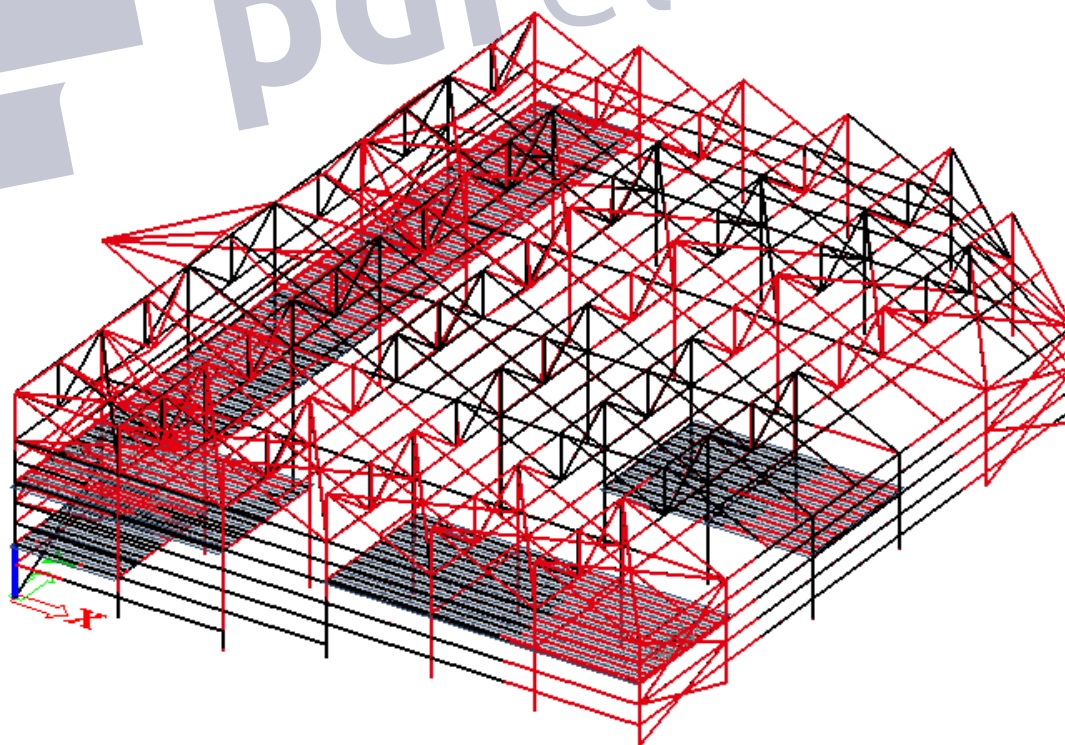

Slika 74: Prikaz deformacije konstrukcije

Provedena analiza stabilnosti dala je odgovore da se radi o nepomičnoj konstrukciji što je uzeto u obzir tijekom dimenzioniranja objekta.

Tijekom dimenzioniranja objekta korištene su systemske duljine izvijanja elemenata konstrukcije.

 pdfelement

## 7. SPOJEVI

### 7.1 Spoj stupa s temeljom

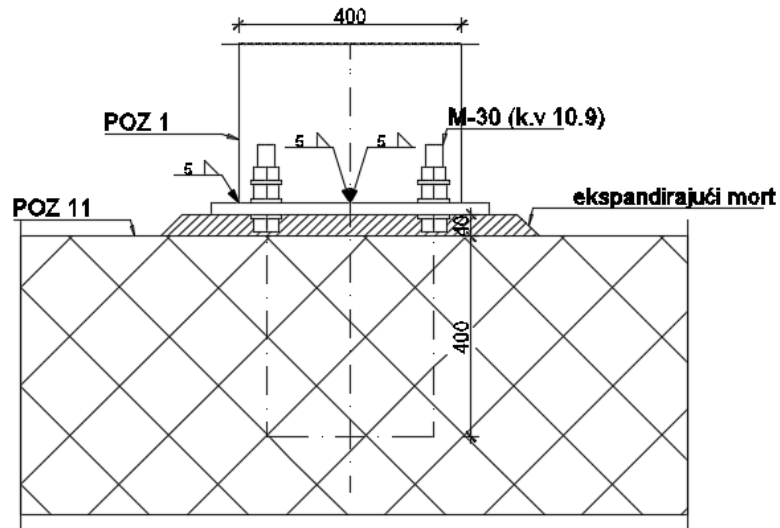

Slika 75: Pogled na spoj

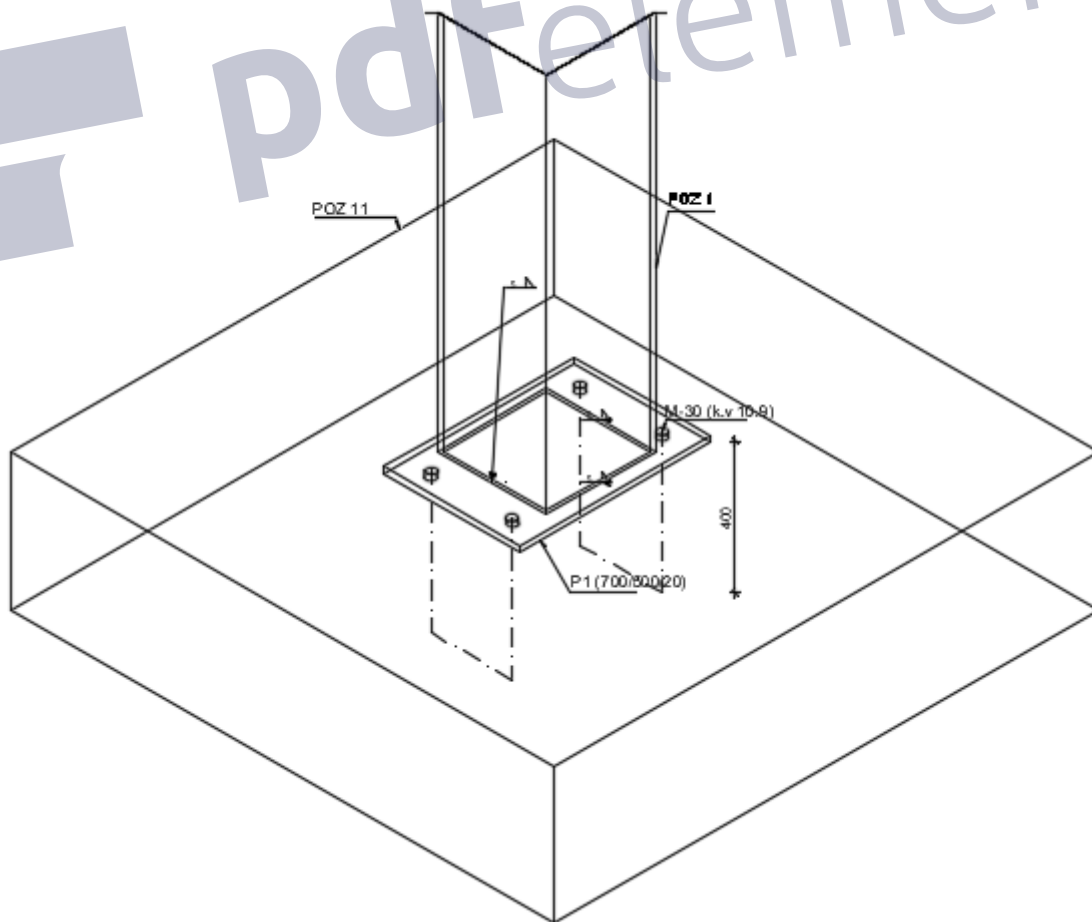

Slika 76: Izometrijski prikaz spoja

Dimenzioniranje elementa je provedeno u softveru (modul Steel)

### Steel Connection

Name	Conn
Node	N64
Connection type	Frame bolted
Connection geometry	Column base
Calculation type	Internal forces
Lc/Combi	GSN 3

Connected beams

Name	CrossSection	Material	Length [m]	Beg. node	End node	Type
B63	CS9 - F400X10	S 275	10.500	N64	N36	column (100)

#### Parts of connection

Bolts

M30 - 4.6 (ISO 4014, ISO 4032, ISO 7089)			
Name		Bolt pattern	2 bolts/row
Internal bolts distance [mm]	300	External bolts distance [mm]	
Length [mm]	1525	Reference	Bottom of the beam
1.Location [mm]	475	2.Location [mm]	-75

End-plate

EP1			
Material	S 275	Left extension [mm]	50
Thickness[mm]	20	Right extension [mm]	50
Input	Top/Bottom/Left/Right	Total width [mm]	500
Top extension [mm]	150	Total height [mm]	700
Bottom extension [mm]	150		

#### Connection analysis: Side [B63]

According to EN 1993-1-8

National annex: Standard EN

Partial safety factors	
Gamma M0	1.00
Gamma M1	1.00
Gamma M2	1.25
Gamma M3	1.25
Gamma c	1.50

**1. Internal forces**

GSN 3		
NEd	-889.49	kN
Vz,Ed	41.44	kN
My,Ed	-72.48	kNm

Tension on left side.

**2. Design compression resistance  $NR_{d,c}$** 

According to EC3, Annex L

NR <sub>d,c</sub> data		
f <sub>cd</sub>	16.67	MPa
f <sub>j</sub>	20.00	MPa
c	42.82	mm
Resulting bearing area	149190.42	mm <sup>2</sup>
NR <sub>d,c</sub>	2983.81	kN

**3. Design moment resistance  $M_{j,y,Rd}$** 

According to EN 1993-1-8 and CIDECT regulations

**3.1. Design resistance of basic components****3.1.1. Concrete in compression.**

F <sub>c,base,Rd</sub> data		
F <sub>c,base,Rd</sub>	928.87	kN
Area under compression flange	46443.64	mm <sup>2</sup>

**3.1.2. Column flange and web in compression (EN 1993-1-8 6.2.5.2 )**

F <sub>c,fb,Rd</sub> data		
Section class	3	
M <sub>c,Rd</sub>	525.52	kNm
h <sub>b</sub> -t <sub>fb</sub>	390.00	mm
F <sub>c,fb,Rd</sub>	1347.50	kN

**3.1.3. Design tension resistance of anchor row**

(lengths in mm , resistance in kN)

F <sub>t,Rd</sub> data		
f <sub>ub</sub>	1000.00	MPa
A <sub>s</sub>	561.00	mm <sup>2</sup>
k <sub>2</sub>	0.90	-
F <sub>t,Rd</sub>	403.92	kN
L <sub>b</sub>	306.80	mm

Note: The bolt-rows are numbered starting from the bolt-row farthest from the centre of compression as given by EN 1993-1-8 Article 6.2.7.2 (1).

row	a	b	b'	Ft,ep,Rd
1	75.00	75.00	70.00	259.52
2	75.00	75.00	70.00	259.52

row-bolt	p	delta	K [mm <sup>2</sup> /kN]	alpha	Ft
1- 1	200.00	0.83	5.66	3.17	129.76
1- 2	200.00	0.83	5.66	3.17	129.76
2- 1	200.00	0.83	5.66	3.17	129.76
2- 2	200.00	0.83	5.66	3.17	129.76

### 3.2. Determination of Mj,y,Rd

According to EN 1993-1-8 Article 6.2.7.2 (1)

row	hr[mm]	Ft,r,Rd[kN]
1	470.00	259.52
2	-80.00	0.00

**Mj,y,Rd = 121.98 kNm**

### 4. Design tension resistance Nj,Rd

According to EN 1993-1-8

**NRd,t = 519.04 kN**

### 5. Design shear resistance VRd

Vz,Rd data		
Vz,Rd	196.19	kN
Fv,Rd	76.30	kN
The yield strength of the anchor bolt >	640.00	MPa
e1,ep	75.00	mm
p1	550.00	mm
Alfa_d plate	0.76	
Alfa_b plate	0.76	
Fb,ep,Rd	390.91	kN
Alfa_b (6.2) plate	0.17	
F1,vb,Rd	224.40	kN
F2,vb,Rd	76.30	kN

### 6. Stiffness calculation

Not applicable for CIDECT regulations.

#### 6.1. Ductility classification

In the endplate we have the following :

$t \leq 0.36 \sqrt{f_{ub}/f_y} d$

This results in a ductile classification for ductility : class 1.

### 7. Design Calculations.

#### 7.1. Anchorage length

Designed for loadcase/Combi: GSN 1



Anchorage data		
Ft,anchor,max	234.62	kN
As,req	325.86	mm <sup>2</sup>
As,prov	561.00	mm <sup>2</sup>
lb	2434.69	mm
a	1.00	
lb,net	1414.19	mm
lb,min	730.41	mm
l,anchor	1414.19	mm

## 7.2. Calculation weldsize

### 7.2.1. Calculation weld size

data		
M	121.98	kNm
N	950.08	kN
V	41.44	kN
fu	430.00	MPa
$\beta_w$	0.85	
a	5.00	mm
l1	350.00	mm
l2	340.00	mm
A	6900.00	mm <sup>2</sup>
I	172753333.33	mm <sup>4</sup>
minimum a	4.80	mm
aw	5.00	mm
af	5.00	mm

...:RESULTS:...

## 8. Unity checks

Unity checks	
My,Ed/Mj,y,Rd	0.59
Vz,Ed/Vz,Rd	0.21

The connection satisfies.

## 7.2 Spoj međukatne grede sa stupom

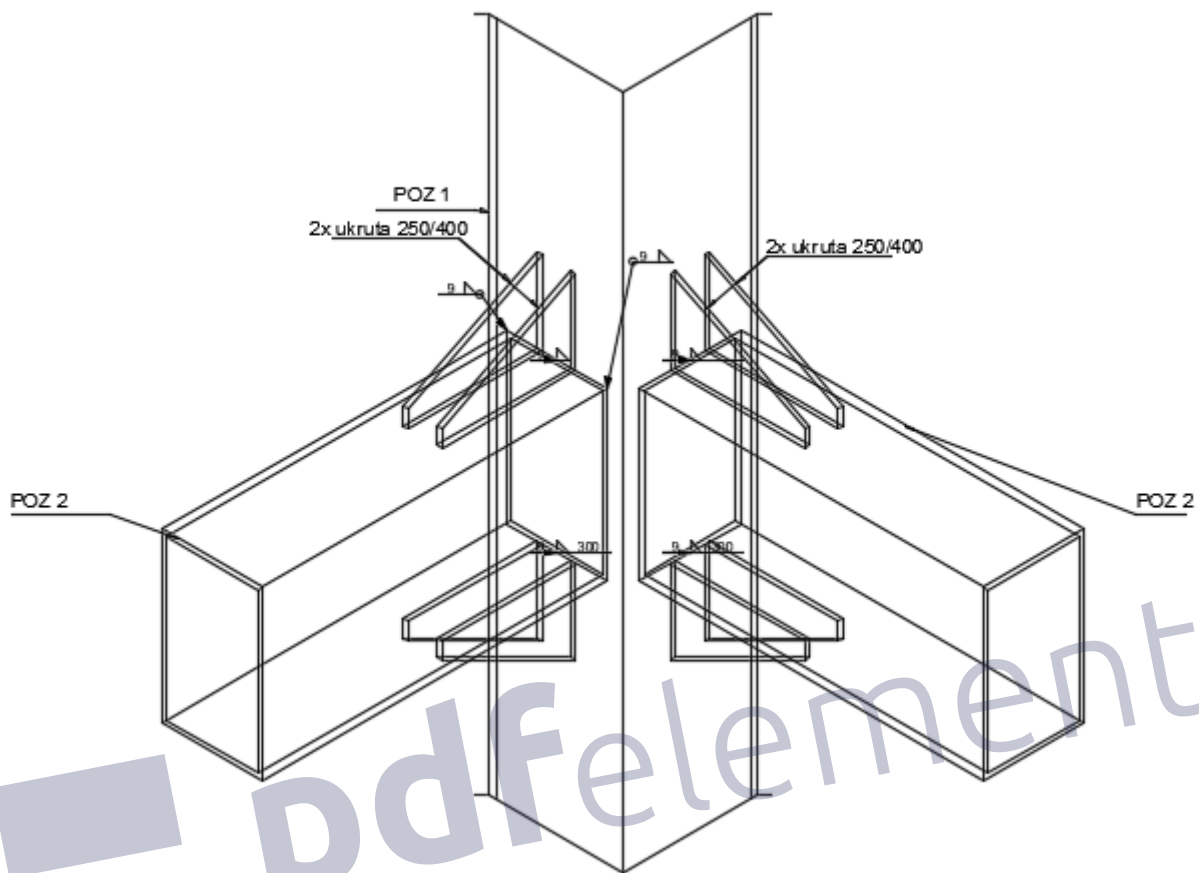

Slika 77: Izometrijski prikaz spoja

### POPREČNI PRESJEK-

RHS 500/300/13/13/10 mm -greda

RHS 400/400/10 mm -stup

### MATERIJAL

Osnovni materijal: S 275

### REZNE SILE

$$N_{sd} = 1459,85 \text{ kN}$$

$$V_{sd} = 199.95 \text{ kN}$$

$$M_{sd} = 520.93 \text{ kNm}$$

Pojasnice

- vlačna sila u pojasu od momenta savijanja:

$$N_p^M = \frac{M_{sd}}{h - t_f} = \frac{520,93}{0,300 - 0,013} = \frac{520,93}{(0,287)} = 1815,08 \text{ kNm}$$

- ukupna vlačna sila u pojasnici

$$N_p = N_p^M + N_p^N = 1815,08 + 1459,85 = 3274,93 \text{ kN}$$

Izračun vara

- max debljina vara s obzirom na debljinu pojaseva nosača:

$$a_{\max} = 0,7 \cdot t_{\min} = 0,7 \cdot 13 = 9,0 \text{ (mm)} \rightarrow \text{odabrano } a = 9 \text{ mm}$$

Duljina vara na pojasnicama: dodajemo dvije ukrute na pojasnicu visine 250 mm

- duljina vara pojasnice:

$$l_p = 2 \cdot b = 2 \cdot 300 + 4 \cdot 250 = 1600 \text{ mm}$$

- max debljina vara s obzirom na debljinu hrpta nosača:

$$a_{\max} = 0,7 \cdot t_{\min} = 0,7 \cdot 10 = 7,0 \text{ (mm)} \rightarrow \text{odabrano } a = 7 \text{ mm}$$

- duljina vara hrpta:

$$l_h = 2 \cdot d = 1000 \text{ (mm)}$$

Za pretpostavljeni var a = 9 (mm):

- uzdužna sila:

$$F_{w,Rd} = \frac{F_{w,Rk}}{1,25} \cdot \frac{L}{100} = \frac{262,9}{1,25} \cdot \frac{1600}{100} = 3365,12 \text{ (kN)}$$

uvjet nosivosti

$$N_p = F_{w,Sd} \leq F_{w,Rd}$$

$$3274,93 \text{ (kN)} < 3365,12 \text{ (kN)}$$

Za pretpostavljeni var  $a = 9 \text{ (mm)}$ :

- poprečna sila:

$$F_{w,Rd} = \frac{F_{w,Rk}}{1,25} \cdot \frac{L}{100} = \frac{204,4}{1,25} \cdot \frac{1000}{100} = 1635,2 \text{ (kN)}$$

uvjet nosivosti

$$V_{Sd} \leq F_{w,Rd}$$

$$199,95 \text{ (kN)} \leq 1635,2 \text{ (kN)}$$

→ Varovi zadovoljavaju

Provjera vara direktnom metodom zbog velike uzdužne sile koja se javlja.

Proračun vara između grede i stupa uzimajući u obzir i ukrute koje su proračunate.

Pojasnica

$a = 9 \text{ mm}$  – debljina vara

$L = 1600 \text{ mm}$  – duljina vara

1. uvjet:

$$\sigma_{\perp} = \frac{N_{Ed}}{A} = \frac{3274,08 \cdot 100}{9 \cdot 1600} = 22.736 \text{ MPa} < 0.9 \cdot \frac{f_u}{\gamma_{M2}} = 0.9 \cdot \frac{490}{1.25} = 352.80 \text{ MPa}$$

→Uvjet zadovoljen

$$\tau_{\parallel} = \frac{V_{Ed} \cdot S}{I \cdot b} = \frac{199,95 \cdot 100 \cdot 288\,000}{3\,072\,000\,000,0 \cdot 9} = 2.08 \text{ Mpa}$$

$$I = \frac{b \cdot h^3}{12} = \frac{9 \cdot 1600^3}{12} = 3\,072\,000\,000 \text{ mm}^4 - \text{moment tromosti}$$

$$S = \frac{1600}{2} \cdot 9 \cdot \frac{1600}{4} = 288\,000\,0 \text{ mm}^3 - \text{statički moment površine}$$

$$\tau_{\perp} = \frac{N_{Ed} \cdot S}{I \cdot h} = \frac{3274,08 \cdot 100 \cdot 16200}{97200 \cdot 1600} = 34.105 \text{ Mpa}$$

$$I = \frac{h \cdot b^3}{12} = \frac{1600 \cdot 9^3}{12} = 9\,7200 \text{ mm}^4 - \text{moment tromosti}$$

$$S = 1600 \cdot 4.5 \cdot 2,25 = 16200 \text{ mm}^3 - \text{statički moment površine}$$

2. uvjet:

$$\frac{[\sigma_{\perp}^2 + 3(\tau_{\perp}^2 + \tau_{\parallel}^2)]^{0.5}}{2} \leq \frac{f_u}{\beta \cdot \gamma_{M2}}$$

$$\frac{[\sigma_{\perp}^2 + 3(\tau_{\perp}^2 + \tau_{\parallel}^2)]^{0.5}}{2} = \frac{[22.736^2 + 3(34.105^2 + 2.08^2)]^{0.5}}{2} = 15.84 \text{ Mpa}$$

$$\frac{f_u}{\beta \cdot \gamma_{M2}} = \frac{490}{0.9 \cdot 1.25} = 435.55 \text{ MPa}$$

15.84 Mpa &lt; 435.55 Mpa →Uvjet zadovoljen

Greda je predviđena da se vari u radionici na stup i tako doprema na gradilište te se kasnije na objektu izvode nastavci grede koji su također proračunati.

### 7.3 Dimenzioniranje nastavka međukatne grede

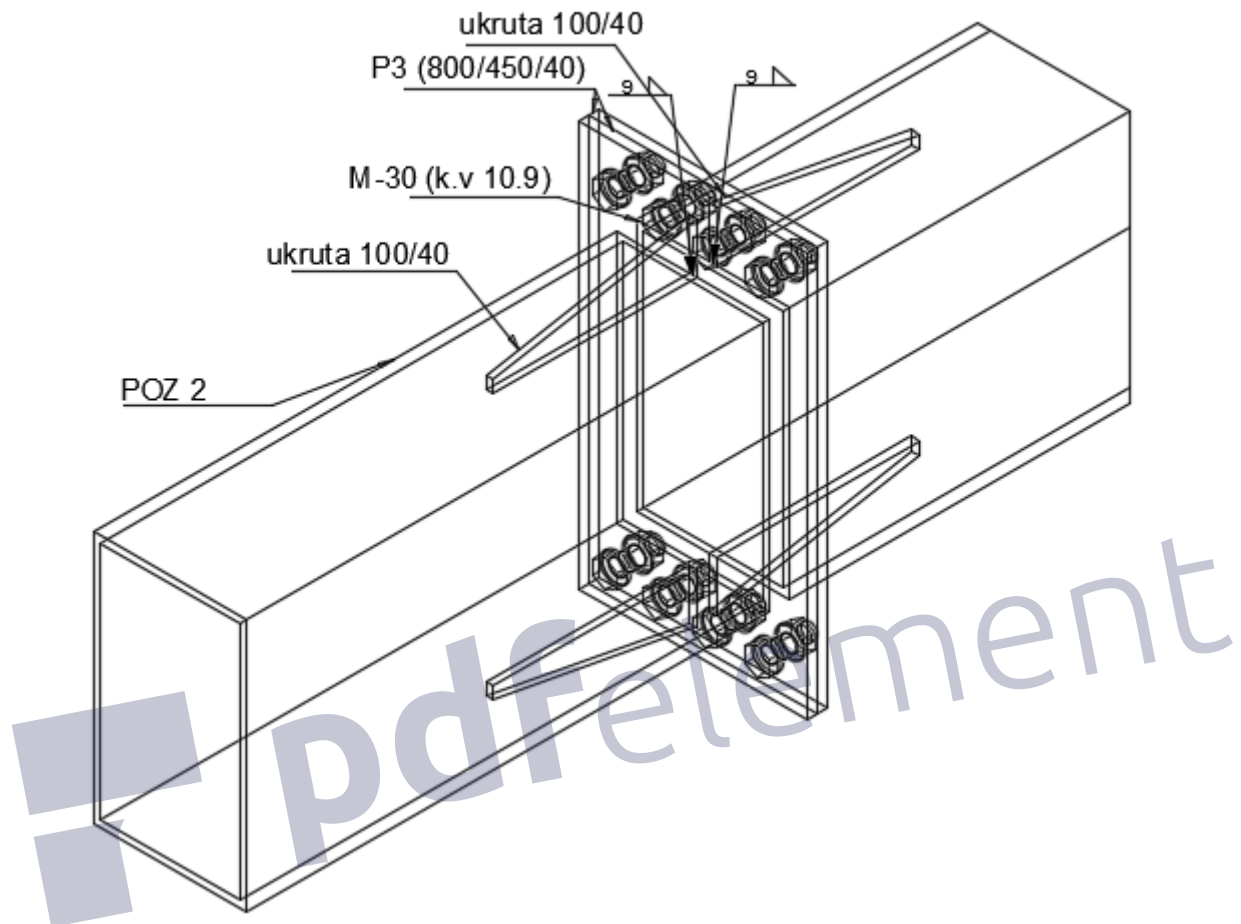

Slika 78: Izometrijski prikaz spoja

#### POPREČNI PRESJEK-

RHS 500/300/13/13/10 mm

#### MATERIJAL

Osnovni materijal: **S 275**

**Vijci: M30, 10.9 k.v.**

#### REZNE SILE

$$N_{sd} = 1412,74 \text{ kN}$$

$$V_{sd} = 112.66 \text{ kN}$$

Izračun vara

- max debljina vara s obzirom na debljinu pojaseva nosača:

$$a_{\max} = 0,7 \cdot t_{\min} = 0,7 \cdot 13 = 9,0 \text{ (mm)} \rightarrow \text{odabrano } a = 9 \text{ mm}$$

Duljina vara na pojasnicama: dodajemo ukrutu na pojasnicu visine 100 mm

- duljina vara pojasnice:

$$l_p = 2 \cdot b = 2 \cdot 300 + 2 \cdot 100 = 800 \text{ mm}$$

- max debljina vara s obzirom na debljinu hrpta nosača:

$$a_{\max} = 0,7 \cdot t_{\min} = 0,7 \cdot 10 = 7,0 \text{ (mm)} \rightarrow \text{odabrano } a = 7 \text{ mm}$$

- duljina vara hrpta:

$$l_h = 2 \cdot d = 1000 \text{ (mm)}$$

Za pretpostavljeni var  $a = 9$  (mm):

- uzdužna sila:

$$F_{w,Rd} = \frac{F_{w,Rk}}{1,25} \cdot \frac{L}{100} = \frac{262,9}{1,25} \cdot \frac{800}{100} = 1682,56 \text{ (kN)}$$

uvjet nosivosti

$$N_p = F_{w,Sd} \leq F_{w,Rd}$$

$$1412,74 \text{ (kN)} < 1682,56 \text{ (kN)}$$

Za pretpostavljeni var  $a = 9$  (mm):

- poprečna sila:

$$F_{w,Rd} = \frac{F_{w,Rk}}{1,25} \cdot \frac{L}{100} = \frac{112,6}{1,25} \cdot \frac{1000}{100} = 900,8(kN)$$

uvjet nosivosti

$$V_{Sd} \leq F_{w,Rd}$$

$$112,66(kN) \leq 900,8(kN)$$

→ Varovi zadovoljavaju

### Proračun vijaka

Uz pretpostavku vijaka M-30 udaljenost  $c_{min}$  vijaka od ruba pojasnice iznosi:

Usvojeni  $c = 75$  mm.

#### Otpornost vijaka na vlak

$$F_{t,Rd} = \frac{F_{t,Rk}}{\gamma_{Mb}} = 403,92 \text{ kN} > \frac{F_{t,Sd}}{4} = \frac{1417,12}{4} = 354,28 \text{ kN}$$

#### Otpornost vijaka na posmik

$$F_{v,Rd} = \frac{F_{v,Rk}}{\gamma_{Mb}} = 224,4 \text{ kN} > F_{v,Sd} = \frac{V_{Sd}}{8} = \frac{112,6}{8} = 14,075 \text{ kN}$$

#### Interakcija uzdužne i odrezne sile

$$\frac{F_{v,Sd}}{F_{v,Rd}} + \frac{F_{t,Sd}}{1,4 \cdot F_{t,Rd}} = 0,92 < 1,0$$

### Proračun pločice

Debljina pločice

#### Savijanje ploče od vlačnih vijaka

$$M_{Sd} = F_{t,Sd} \cdot (c + t_f / 2) = 26,571 \text{ kNm}$$

$$M_{Sd} < \frac{W_{min} \cdot f_y}{\gamma_{M0}} = \frac{b_{pl} \cdot t_{pl}^2 \cdot f_y}{6 \cdot \gamma_{M0}} \Rightarrow t_{pl} > \sqrt{\frac{6 \cdot \gamma_{M0} \cdot M_{Sd}}{b_{pl} \cdot f_y}} = \sqrt{\frac{6 \cdot 1,25 \cdot 26,571 \cdot 100}{45 \cdot 27,5}} = 3,98 \text{ cm}$$

Debljina pločice: 40 mm



**7.4 Dimenzioniranje spoja kose krovne grede sa pojasom krovne rešetke**POPREČNI PRESJEK-

HEA 320A -kosa greda

HEA 320A -pojas rešetke

MATERIJALOsnovni materijal: **S 275****Vijci: M20, 10.9 k.v.**REZNE SILE

$$N_{sd} = 36,81 \text{ kN}$$

$$V_{sd} = 57,39 \text{ kN}$$

$$M_{sd} = 100,06 \text{ kNm}$$

Pojasnice

- vlačna sila u pojasu od momenta savijanja:

$$N_p^M = \frac{M_{sd}}{h-t_f} = \frac{100,06}{0,301-0,011} = \frac{100,06}{0,29} = 345,03 \text{ kNm}$$

-ukupna vlačna sila u pojasnici

$$N_p = N_p^M + N_p^N = 345,03 + 36,81 = 381,81 \text{ kN}$$

Izračun vara

- max debljina vara s obzirom na debljinu pojaseva nosača:

$$a_{\max} = 0,7 \cdot t_{\min} = 0,7 \cdot 11 = 7,7 \text{ (mm)} \rightarrow \text{odabrano } a = 7 \text{ mm}$$

Duljina vara na pojasnicama: dodajemo ukrutu na pojasnicu visine 100 mm

- duljina vara pojasnice:

$$l_p = 2 \cdot b = 2 \cdot 300 + 2 \cdot 100 = 800 \text{ mm}$$

- max debljina vara s obzirom na debljinu hrpta nosača:

$$a_{\max} = 0,7 \cdot t_{\min} = 0,7 \cdot 8 = 5,0 \text{ (mm)} \rightarrow \text{odabrano } a = 5 \text{ mm}$$

- duljina vara hrpta:

$$l_h = 2 \cdot d = 1000 \text{ (mm)}$$

Za pretpostavljeni var  $a = 7 \text{ (mm)}$ :

- uzdužna sila:

$$F_{w,Rd} = \frac{F_{w,Rk}}{1,25} \cdot \frac{L}{100} = \frac{204,4}{1,25} \cdot \frac{300}{100} = 490,56 \text{ (kN)}$$

uvjet nosivosti

$$N_p = F_{w,Sd} \leq F_{w,Rd}$$

$$381,81 \text{ (kN)} < 490,56 \text{ (kN)}$$

Za pretpostavljeni var  $a = 5 \text{ (mm)}$ :

- poprečna sila:

$$F_{w,Rd} = \frac{F_{w,Rk}}{1,25} \cdot \frac{L}{100} = \frac{146,0}{1,25} \cdot \frac{280}{100} = 327,04 \text{ (kN)}$$

uvjet nosivosti

$$V_{Sd} \leq F_{w,Rd}$$

$$57,39 \text{ (kN)} \leq 327,04 \text{ (kN)}$$

→ Varovi zadovoljavaju

### Proračun vijaka

Uz pretpostavku vijaka M-20 udaljenost  $c_{min}$  vijaka od ruba pojasnice iznosi:

Usvojeni  $c = 60 \text{ mm}$ .

- ekscentricitet uzdužne sile

$$e = \frac{M_{Sd}}{N_{Sd}} = 2,71 \text{ (m)}$$

$$x_1 = h - t_f / 2 = 294,5 \text{ (mm)}$$

$$x_2 = e - h/2 + t_f / 2 = 2565,5 \text{ (mm)}$$

$$N_{sd} \cdot x_2 = F_{t,sd} \cdot x_1$$

$$\Rightarrow F_{t,sd} = N_{sd} \cdot \frac{x_2}{x_1} = 320,66 \text{ (kN)}$$

#### Otpornost vijaka na vlak

$$F_{t,Rd} = \frac{F_{t,Rk}}{\gamma_{Mb}} = 176,4 \text{ kN} > \frac{F_{t,Sd}}{2} = \frac{320,66}{2} = 160,33 \text{ kN}$$

#### Otpornost vijaka na posmik

$$F_{v,Rd} = \frac{F_{v,Rk}}{\gamma_{Mb}} = 121,2 \text{ kN} > F_{v,Sd} = \frac{V_{Sd}}{4} = \frac{57,39}{4} = 14,347 \text{ kN}$$

#### Interakcija uzdužne i odrezne sile

$$\frac{F_{v,Sd}}{F_{v,Rd}} + \frac{F_{t,Sd}}{1,4 \cdot F_{t,Rd}} = 0,95 < 1,0$$

#### Proračun pločice

##### Debljina pločice

#### Savijanje ploče od vlačnih vijaka

$$M_{Sd} = F_{t,Sd} \cdot (c + t_f / 2) = 22,58 \text{ kNm}$$

$$M_{Sd} < \frac{W_{\min} \cdot f_y}{\gamma_{M0}} = \frac{b_{pl} \cdot t_{pl}^2 \cdot f_y}{6 \cdot \gamma_{M0}} \Rightarrow t_{pl} > \sqrt{\frac{6 \cdot \gamma_{M0} \cdot M_{Sd}}{b_{pl} \cdot f_y}} = \sqrt{\frac{6 \cdot 1,25 \cdot 22,58 \cdot 100}{50 \cdot 27,5}} = 3,48 \text{ cm}$$

Debljina pločice: 35 mm

## 7.5 Spoj stupa i krovne rešetke

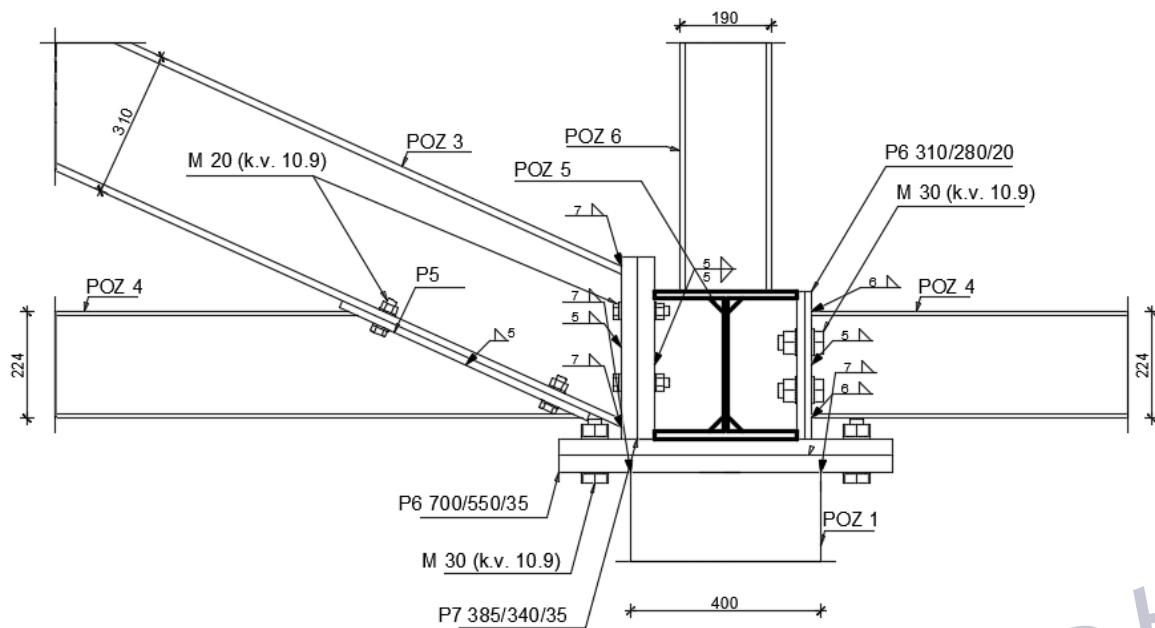

Slika 79: Pogled na spoj

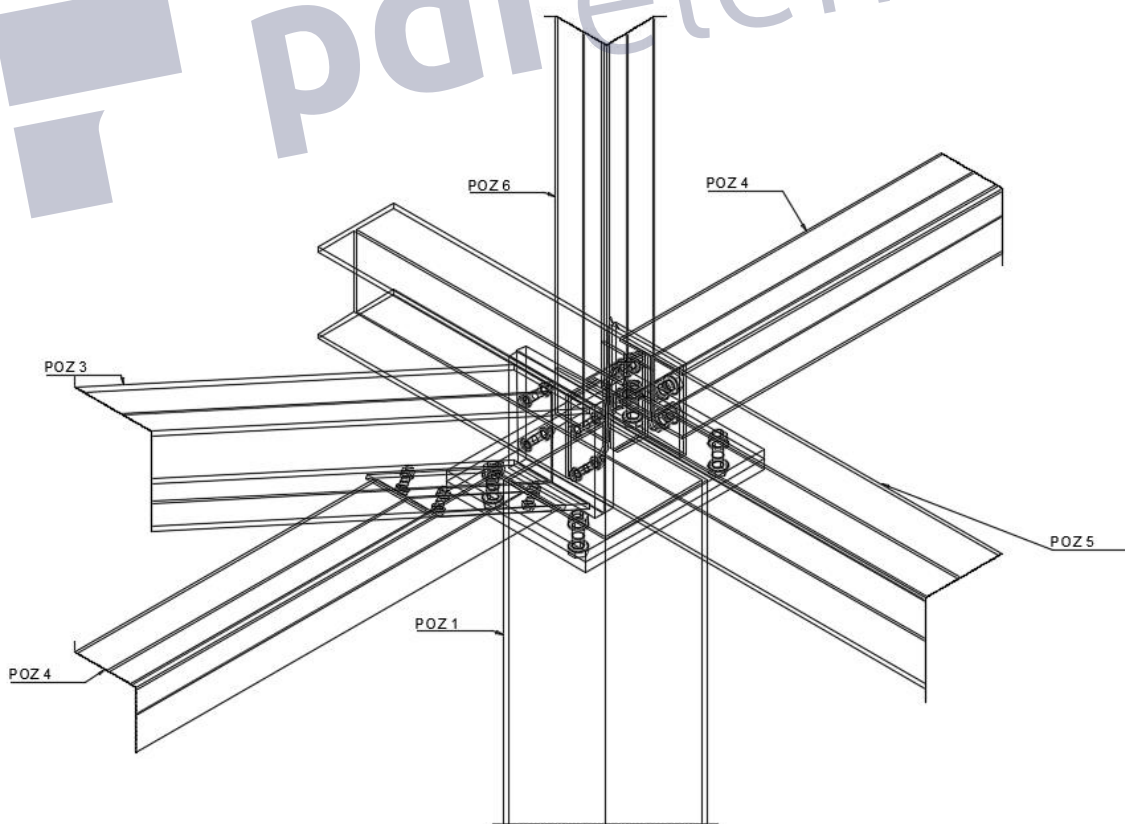

Slika 80: Izometrijski prikaz spoja

POPREČNI PRESJEK-

HEA 320A -pojasnica krovne rešetke

RHS 400/400/10 -stup

MATERIJALOsnovni materijal: **S 275****Vijci: M30, 10.9 k.v.**REZNE SILE

$$N_{sd} = 268,72 \text{ kN}$$

$$V_{sd} = 32,7 \text{ kN}$$

$$M_{sd} = 93,64 \text{ kNm}$$

- vlačna sila u spoju od momenta savijanja:

$$N_p^M = \frac{M_{sd}}{h - t_f} = \frac{93,64}{0,301 - 0,011} = \frac{93,64}{(0,29)} = 321,01 \text{ kNm}$$

Izračun vara

- max debljina vara s obzirom na debljinu pojaseva nosača:

$$a_{\max} = 0,7 \cdot t_{\min} = 0,7 \cdot 11 = 7,7 \text{ (mm)} \rightarrow \text{odabrano } a = 7 \text{ mm}$$

Duljina vara:

- duljina vara pojasnice u y smjeru:

$$l_p = 2 \cdot b = 2 \cdot 300 = 600 \text{ mm}$$

- duljina vara pojasnice u x smjeru:

$$l_h = 300 \text{ mm}$$

- uzdužna sila y smjer:

$$F_{w,Rd} = \frac{F_{w,Rk}}{1,25} \cdot \frac{L}{100} = \frac{204,4}{1,25} \cdot \frac{600}{100} = 981,12 \text{ (kN)}$$

uvjet nosivosti

$$N_p = F_{w,Sd} \leq F_{w,Rd}$$

$$268,72 \text{ (kN)} < 981,12 \text{ (kN)}$$

- poprečna sila z smjer:

$$F_{w,Rd} = \frac{F_{w,Rk}}{1,25} \cdot \frac{L}{100} = \frac{204,4}{1,25} \cdot \frac{300}{100} = 490,56 \text{ (kN)}$$

uvjet nosivosti

$$V_{Sd} \leq F_{w,Rd}$$

$$324,01 \text{ (kN)} \leq 490,56 \text{ (kN)}$$

→ Varovi zadovoljavaju

### Proračun vijaka

Uz pretpostavku vijaka M-30 udaljenost  $c_{min}$  vijaka od ruba pojasnice iznosi:

Usvojeni  $c = 75 \text{ mm}$ .

#### Otpornost vijaka na vlak

$$F_{t,Rd} = \frac{F_{t,Rk}}{\gamma_{Mb}} = 323,12 \text{ kN} > \frac{F_{t,Sd}}{2} = \frac{324,01}{2} = 162,0 \text{ kN}$$

#### Otpornost vijaka na posmik

$$F_{v,Rd} = \frac{F_{v,Rk}}{\gamma_{Mb}} = 176,24 \text{ kN} > F_{v,Sd} = \frac{V_{Sd}}{4} = \frac{368,72}{4} = 92,18 \text{ kN}$$

#### Interakcija uzdužne i odrezne sile

$$\frac{F_{v,Sd}}{F_{v,Rd}} + \frac{F_{t,Sd}}{1,4 \cdot F_{t,Rd}} = 0,88 < 1,0$$

Proračun pločice

Debljina pločice

Savijanje ploče od vlačnih vijaka

$$M_{Sd} = F_{t,Sd} \cdot (c + t_f / 2) = 24.3 \text{ kNm}$$

$$M_{Sd} < \frac{W_{\min} \cdot f_y}{\gamma_{M0}} = \frac{b_{pl} \cdot t_{pl}^2 \cdot f_y}{6 \cdot \gamma_{M0}} \Rightarrow t_{pl} > \sqrt{\frac{6 \cdot \gamma_{M0} \cdot M_{Sd}}{b_{pl} \cdot f_y}} = \sqrt{\frac{6 \cdot 1,25 \cdot 24,3 \cdot 100}{60 \cdot 27,5}} = 3.32 \text{ cm}$$

Debljina pločice: 35 mm

 pdfelement

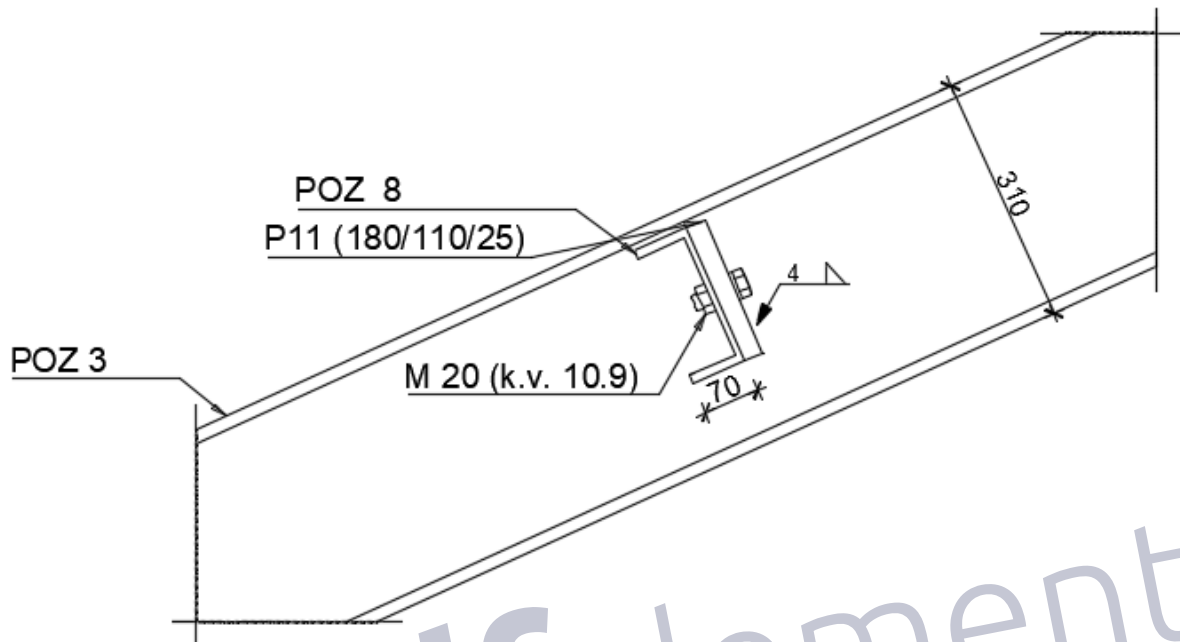
**7.6 Spoj kose krovne grede sa krovnom podrožnicom**

Slika 81: Prikaz pogleda spoja

**POPREČNI PRESJEK-**

HEA 320A            -kosa krovna greda  
 U 180                -krovna podrožnica

**MATERIJAL**

Osnovni materijal:    **S 275**

**Vijci: M20, 10.9 k.v.**

**REZNE SILE**

$N_{sd} = 92,45 \text{ kN}$

**Izračun vara**

- max debljina vara s obzirom na debljinu spojne pločice :

$$a_{\max} = 0,7 \cdot t_{\min} = 0,7 \cdot 10 = 7,0 \text{ (mm)} \rightarrow \text{odabrano } a = 4 \text{ mm}$$



Duljina vara:

- duljina vara jednaka je visini spojne pločice:

$$l_h = 180 \text{ mm}$$

- uzdužna sila:

$$F_{w,Rd} = \frac{F_{w,Rk}}{1,25} \cdot \frac{L}{100} = \frac{116,8}{1,25} \cdot \frac{180}{100} = 168,192 \text{ (kN)}$$

uvjet nosivosti

$$N_p = F_{w,Sd} \leq F_{w,Rd}$$

$$92,45 \text{ (kN)} < 168,192 \text{ (kN)}$$

→ Varovi zadovoljavaju

### Proračun vijaka

Uz pretpostavku vijaka M-20 udaljenost  $c_{min}$  vijaka od ruba pojasnice iznosi:

Usvojeni  $c = 60 \text{ mm}$ .

### Otpornost vijaka na posmik

$$F_{v,Rd} = \frac{F_{v,Rk}}{\gamma_{Mb}} = 98 \text{ kN} > F_{v,Sd} = V_{Sd} = 92,18 \text{ kN}$$

### Proračun pločice

Debljina pločice

#### Pritisak po omotaču rupe osnovnog materijala

$$F_{v,Sd} = V_{Sd} = 92,45 \text{ kN} = F_{b,Sd} < F_{b,Rd} = \frac{F_{b,Rk}}{\gamma_{Mb}} \cdot \frac{t^{pl}}{10} \Rightarrow t^{pl} > \frac{F_{b,Sd} \cdot \gamma_{Mb} \cdot 10}{F_{b,Rk}}$$

$$t^{pl} = 23,58 \text{ mm}$$

Debljina pločice: 25 mm

## 7.7 Spoj stupa i bočne podrožnice

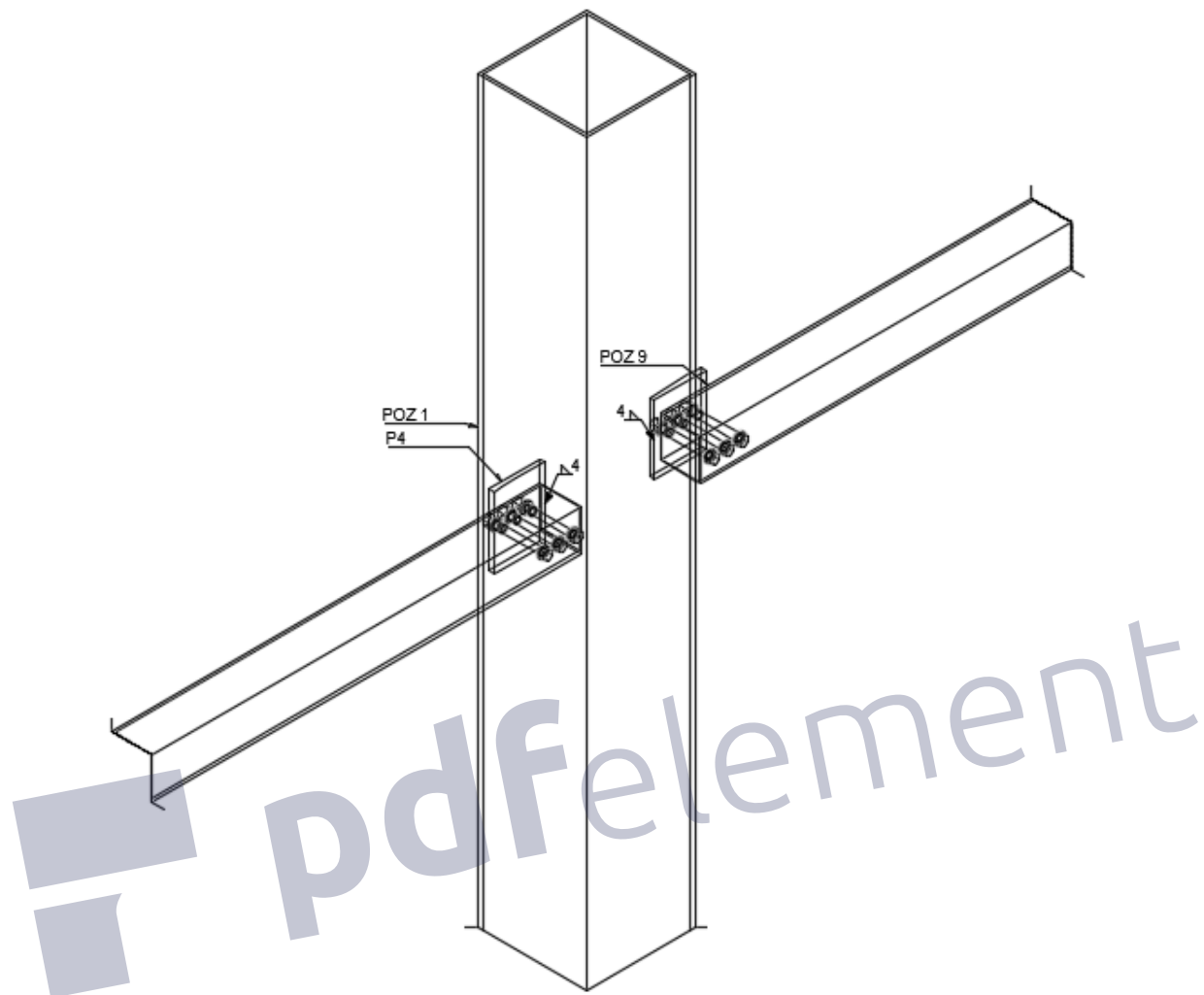

Slika 82: Izometrijski prikaz spoja

### POPREČNI PRESJEK-

RHS 400/10 -stup

RHS 150/5 -bočna podrožnica

### MATERIJAL

Osnovni materijal: **S 275**

**Vijci: M20, 10.9 k.v.**

### REZNE SILE

$$N_{sd} = 218,0 \text{ kN}$$

Izračun vara

- max debljina vara s obzirom na debljinu spojne pločice :

$$a_{\max} = 0,7 \cdot t_{\min} = 0,7 \cdot 10 = 7,0 \text{ (mm)} \rightarrow \text{odabrano } a = 4 \text{ mm}$$

Duljina vara:

- duljina vara jednaka je visini spojne pločice:

$$l_h = 250 \text{ mm}$$

- uzdužna sila:

$$F_{w,Rd} = \frac{F_{w,Rk}}{1,25} \cdot \frac{L}{100} = \frac{116,8}{1,25} \cdot \frac{250}{100} = 233,6 \text{ (kN)}$$

uvjet nosivosti

$$N_p = F_{w,Sd} \leq F_{w,Rd}$$

$$218,0 \text{ (kN)} < 233,6 \text{ (kN)}$$

→ Varovi zadovoljavaju

Proračun vijaka

Uz pretpostavku vijaka M-20 udaljenost  $c_{\min}$  vijaka od ruba pojasnice iznosi:

Usvojeni  $c = 60 \text{ mm}$ .

Otpornost vijaka na posmik

$$F_{v,Rd} = \frac{F_{v,Rk}}{\gamma_{Mb}} = 98 \text{ kN} > F_{v,Sd} = \frac{V_{Sd}}{3} = 72,66 \text{ kN}$$

Proračun pločice

Debljina pločice

Pritisak po omotaču rupe osnovnog materijala

$$F_{v,Sd} = V_{Sd} = 72.66 \text{ kN} = F_{b,Sd} < F_{b,Rd} = \frac{F_{b,Rk}}{\gamma_{Mb}} \cdot \frac{t^{pl}}{10} \Rightarrow t^{pl} > \frac{F_{b,Sd} \cdot \gamma_{Mb} \cdot 10}{F_{b,Rk}}$$

$$t^{pl} = 18.53 \text{ mm}$$

Debljina pločice: 20 mm

 pdfelement

## 7.8 Spoj sprega sa stupom

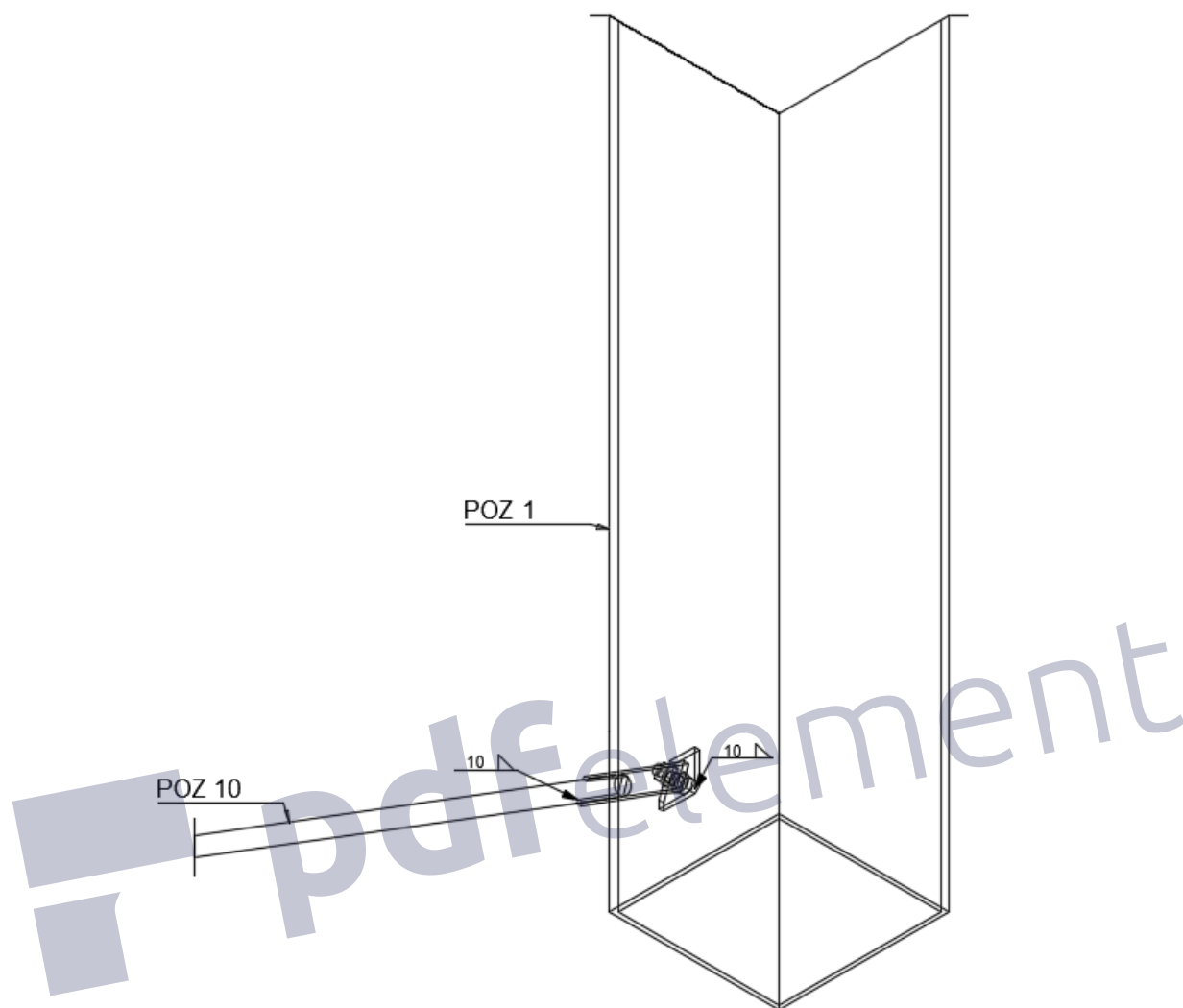

Slika 83: Izometrijski prikaz spoja

### POPREČNI PRESJEK-

RHS 400/400/10 mm -stup

RD 40 -spreg

### MATERIJAL

Osnovni materijal: **S 275**

**Vijci: M20, 10.9 k.v.**

### REZNE SILE

$$N_{sd} = 86,27 \text{ kN}$$

Izračun vara

- max debljina vara s obzirom na debljinu spojne pločice :

$$a_{\max} = 0,7 \cdot t_{\min} = 0,7 \cdot 20 = 14,0 \text{ (mm)} \rightarrow \text{odabrano } a = 10 \text{ mm}$$

Duljina vara:

- duljina vara jednaka je visini spojne pločice:

$$l_h = 40 \text{ mm}$$

- uzdužna sila:

$$F_{w,Rd} = \frac{F_{w,Rk}}{1,25} \cdot \frac{L}{100} = \frac{292,1}{1,25} \cdot \frac{40}{100} = 93,472 \text{ (kN)}$$

uvjet nosivosti

$$N_p = F_{w,Sd} \leq F_{w,Rd}$$

$$86,27 \text{ (kN)} < 93,472 \text{ (kN)}$$

→ Varovi zadovoljavaju

Proračun vijaka

Uz pretpostavku vijaka M-20 udaljenost:

Otpornost vijaka na posmik

$$F_{v,Rd} = \frac{F_{v,Rk}}{\gamma_{Mb}} = 98 \text{ kN} > F_{v,Sd} = V_{Sd} = 86,27 \text{ kN}$$

Proračun pločice

Debljina pločice

Pritisak po omotaču rupe osnovnog materijala

$$F_{v,Sd} = V_{Sd} = 86.27 \text{ kN} = F_{b,Sd} < F_{b,Rd} = \frac{F_{b,Rk}}{\gamma_{Mb}} \cdot \frac{t^{pl}}{10} \Rightarrow t^{pl} > \frac{F_{b,Sd} \cdot \gamma_{Mb} \cdot 10}{F_{b,Rk}}$$

$$t^{pl} = 25.07 \text{ mm}$$

Debljina pločice: 30 mm

### 7.9 Nastavak pojasa krovne rešetke

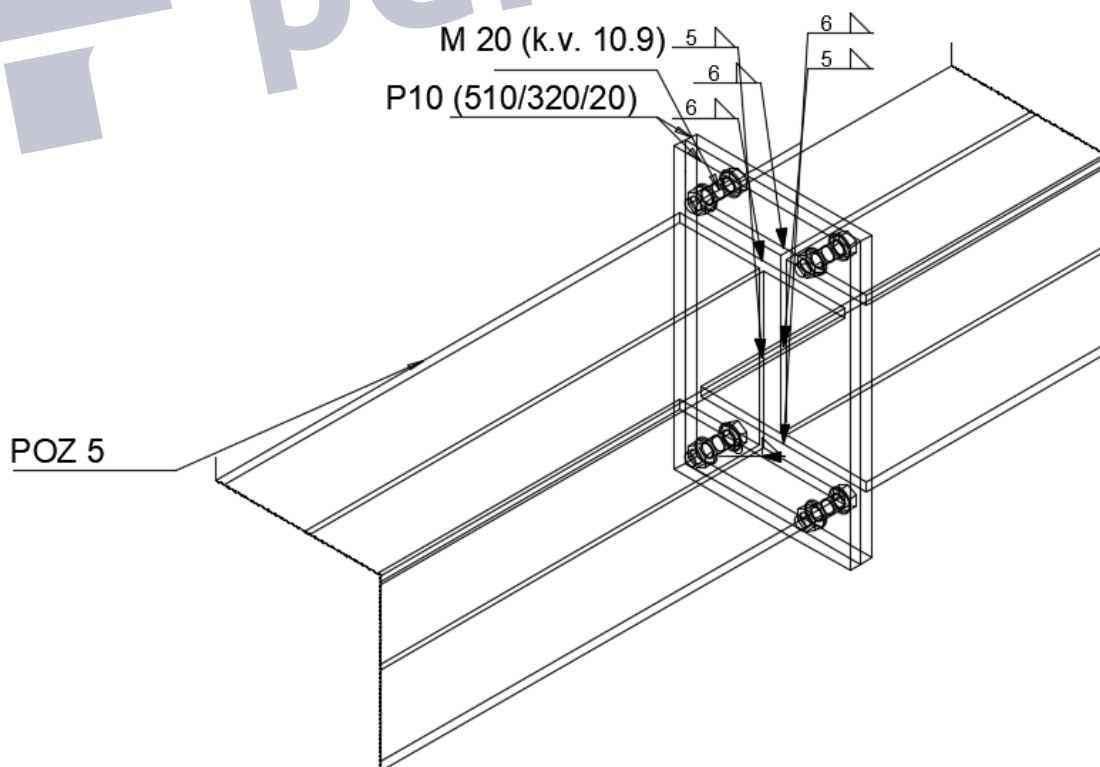

Slika 84: Izometrijski prikaz spoja

Dimenzioniranje elementa je provedeno u softveru (modul Steel)

**Steel Connection**

Name	Conn3
Node	N54
Connection type	Frame bolted
Connection type	Frame bolted
Connection geometry	Splice
Calculation type	Internal forces
Lc/Combi	GSN 4

**Connection analysis (summary): Side [B55]**

Internal forces

NEd	340.98	kN
Vz,Ed	1.71	kN
My,Ed	5.18	kNm
Vy,Ed	-3.80	kN
Mz,Ed	8.73	kNm

**...:STRONG-AXIS CALCULATION:...**

Design resistances

Mj,y,Rd	94.07	kNm
Nj,Rd	510.24	kN
Vz,Rd	99.17	kN

Limiting parts

In tension	End plate in tension
In compression	Beam flange / Haunch in compression

Stiffness

Sj,ini	44.4021	MNm/rad
Sj	44.4021	MNm/rad

Classification - Right side	System RIGID
Classification - Left side	System RIGID
Stiffness check	OK

**...:WEAK-AXIS CALCULATION:...**

Design resistances

Mj,z,Rd	43.03	kNm
Vy,Rd	99.17	kN

Stiffness

Sj,ini	9.6877	MNm/rad
Sj	9.6877	MNm/rad

**...:RESULTS:...**

Unity checks

My,Ed/Mj,y,Rd	0.06
Mz,Ed/Mj,z,Rd	0.20
NEd/Nj,Rd	0.67
Vz,Ed/Vz,Rd	0.02
Vy,Ed/Vy,Rd	0.04
Vz,Ed/Vz,Rd + Vy,Ed/Vy,Rd	0.06
My,Ed/Mj,y,Rd + NEd/Nj,Rd	0.72
My,Ed/Mj,y,Rd + Mz,Ed/Mj,z,Rd	0.26
My,Ed/Mj,y,Rd + Mz,Ed/Mj,z,Rd + NEd/Nj,Rd	0.93

**Moment-rotation diagram: Side [B55] - Strong axis**



## 7.10 Spoj horizontalne krovne grede i krovne rešetke

## Steel Connection

Name	Conn2
Node	N15
Connection type	Frame bolted
Connection geometry	Single-sided
Calculation type	Internal forces
Lc/Combi	GSN 11

## Connection analysis (summary): Side [B309]

Internal forces

NEd	-129.53	kN
Vz,Ed	6.46	kN
My,Ed	-20.97	kNm
Vy,Ed	0.31	kN
Mz,Ed	-0.48	kNm

## ...::STRONG-AXIS CALCULATION::...

Design resistances

Mj,y,Rd	46.64	kNm
Nj,Rd	366.52	kN
Vz,Rd	257.89	kN

Limiting parts

In tension	End plate in tension
In compression	Column web in compression

Stiffness

Sj,ini	6.7404	MNm/rad
Sj	6.7404	MNm/rad

Classification	System SEMI RIGID
Stiffness check	Not ok

## ...::WEAK-AXIS CALCULATION::...

Design resistances

Mj,z,Rd	4.90	kNm
Vy,Rd	357.14	kN

Stiffness

Sj,ini	0.0935	MNm/rad
Sj	0.0935	MNm/rad

## ...::RESULTS::...

Unity checks

My,Ed/Mj,y,Rd	0.45
Mz,Ed/Mj,z,Rd	0.10
NEd/Nj,Rd	0.35
Vz,Ed/Vz,Rd	0.03
Vy,Ed/Vy,Rd	0.00
Vz,Ed/Vz,Rd + Vy,Ed/Vy,Rd	0.03
My,Ed/Mj,y,Rd + NEd/Nj,Rd	0.80
My,Ed/Mj,y,Rd + Mz,Ed/Mj,z,Rd	0.55
My,Ed/Mj,y,Rd + Mz,Ed/Mj,z,Rd + NEd/Nj,Rd	0.90

## Moment-rotation diagram: Side [B309] - Strong axis

## 8. DIMENZIONIRANJE TEMELJA SAMCA

Proračun dimenzija temelja samca.

Dimenzije temelja: 2000x2000x500 mm

Dopušteno naprezanje :  $\sigma = 500$  Mpa

$N_{sd} = 889,69$  kN

$M_{sd} = 72,48$  kN

$h = 50$  cm

$$a = \sqrt{\frac{P}{\sigma}} = \sqrt{\frac{889,69}{500,00}} = 1,33 \text{ m} \Rightarrow \text{odabrano } a = 2,00 \text{ m}$$

Maksimalno djelovanje na temelj:

$$N_{Ed, \max} = 889,69 \text{ [kN] tlak}$$

Težina temelja:  $N_t = 2,0 \cdot 2,0 \cdot 0,5 \cdot 25 = 50,0$  (kN)

$$N_{Ed} = N'_{Ed} + N_t = 889,69 + 50,0 = 939,69 \text{ [kN] tlak}$$

Naprezanje ispod temelja:

$$\sigma_{1,2} \leq \sigma_{dop, tla} = 500,0 \left( \frac{\text{kN}}{\text{m}^2} \right)$$

$$\sigma_{1,2} = \frac{N_{Ed}}{A} \pm \frac{M_{Ed}}{W}$$

$$A = 2,0 \cdot 2,0 = 4,0 \text{ (m}^2\text{)};$$

$$W = \frac{b \cdot a^2}{6} = \frac{2,0^3}{6} = 1,33 \text{ (m}^3\text{)}$$

$$\sigma_{1,2} = \frac{939,69}{4,0} \pm \frac{72,48}{1,33};$$

$$\sigma_1 = 290,67 \text{ kN/m}^2 < 500 \text{ kN/m}^2$$

$$\sigma_2 = 179,16 \text{ kN/m}^2 < 500 \text{ kN/m}^2$$

## 9. NACRTI

 pdfelement

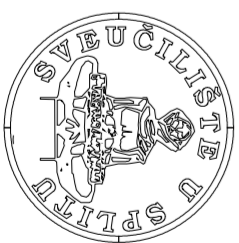
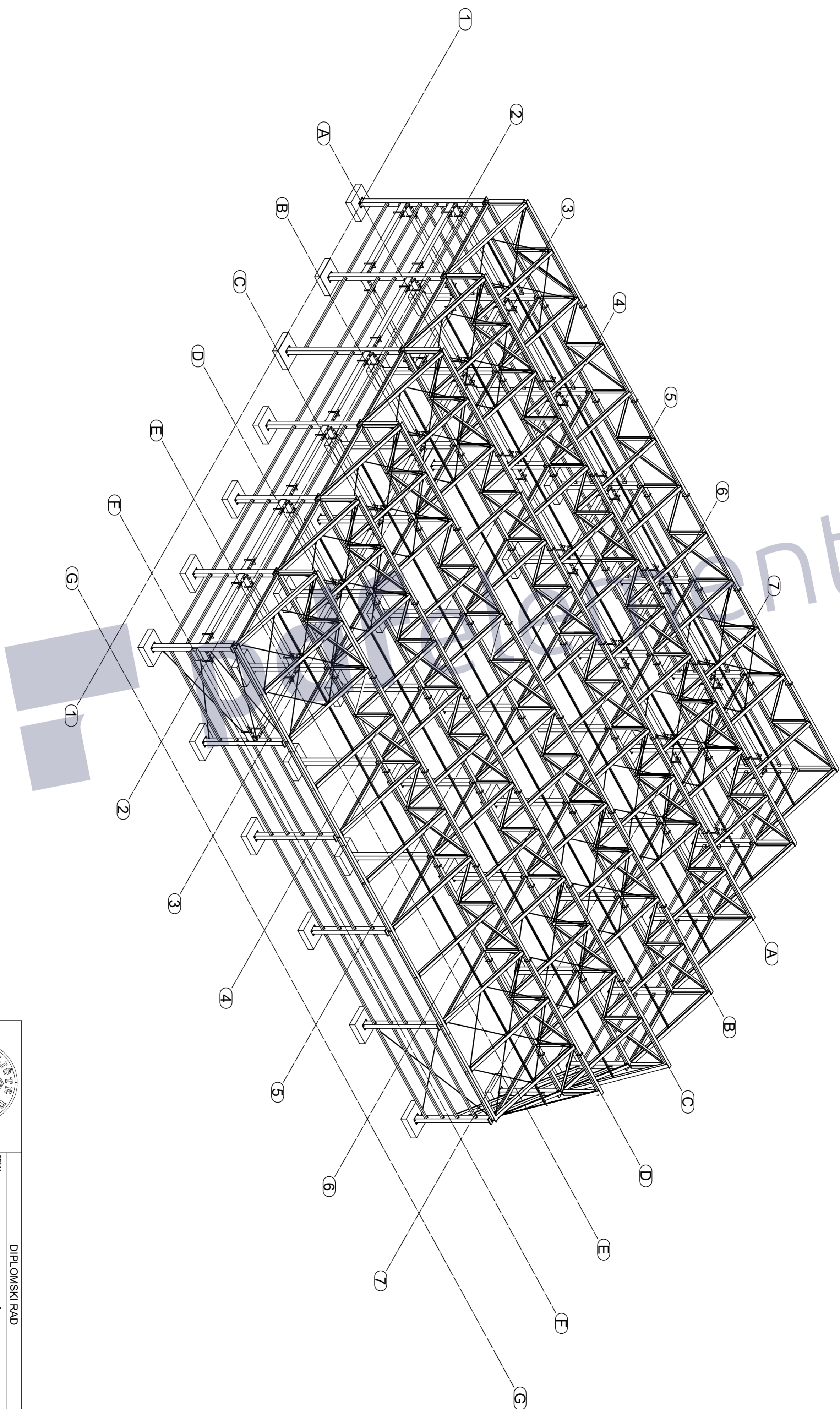

FAKULTET GRAĐEVINARSTVA, ARHITEKTURE I  
KATEDRA ZA VEŠTAČENJE I OSNOVNE KONSTRUKCIJE  
21000 ŠPILT, VANCE, HRVATSKA 15

DIPLOMSKI RAD

TEMA: KONSTRUKCIJA DRUŠTVENOG CENTRA

MEJAŠI

STUDENT:  
Kojundžić Ivan, 587

MENTOR	Prof. dr. sc. I. Boko
ASISTENT	dr. sc. N. Torić dr. sc. I. Uzelac

SAOPRŽAJ	PROSTORNI Prikaz	MALERIKO	1:200
DATUMI	ožujak-lipanj 2017.	PRILOG	1

TLOCRT

POGLED 1-7

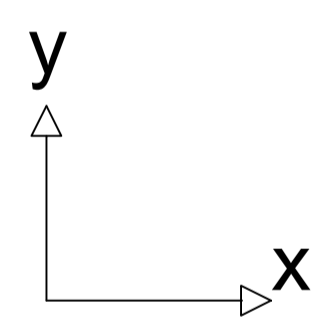
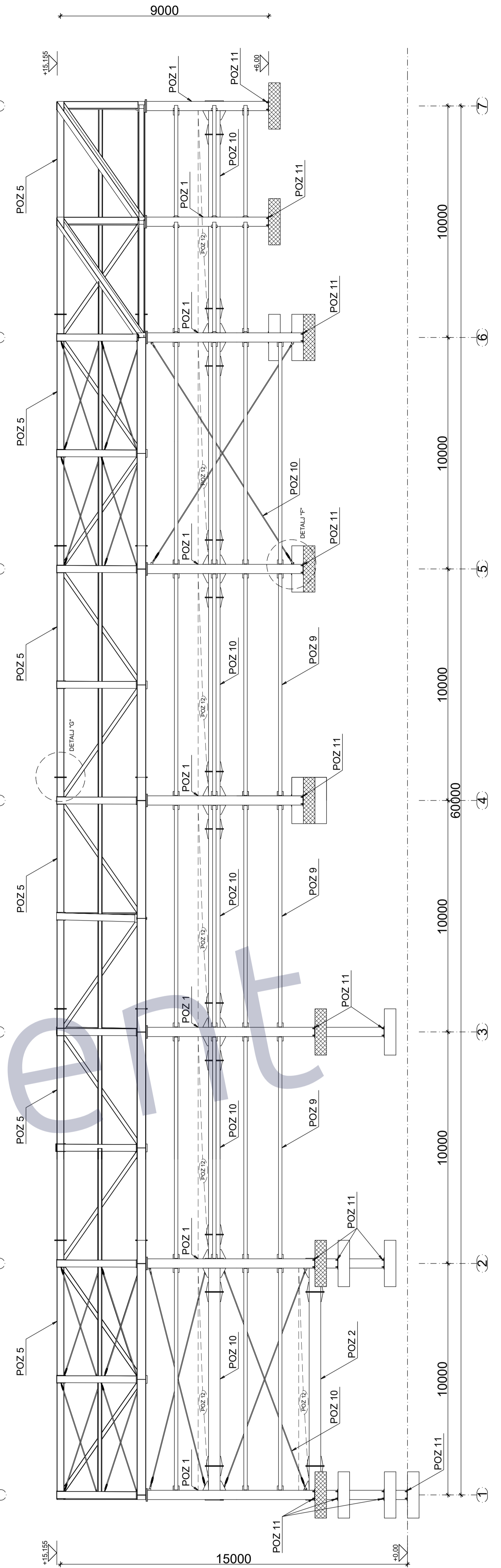
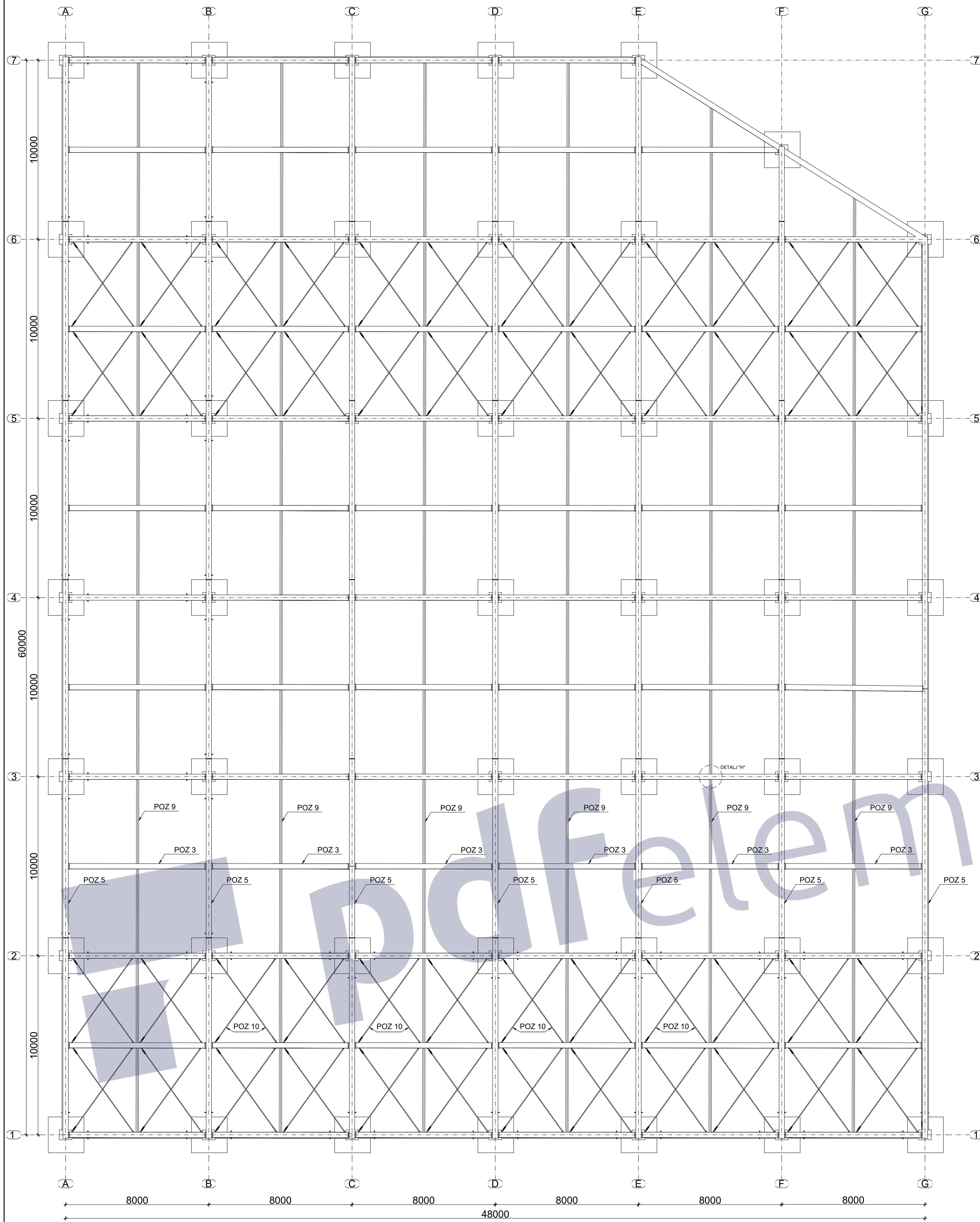

POGLED A-G

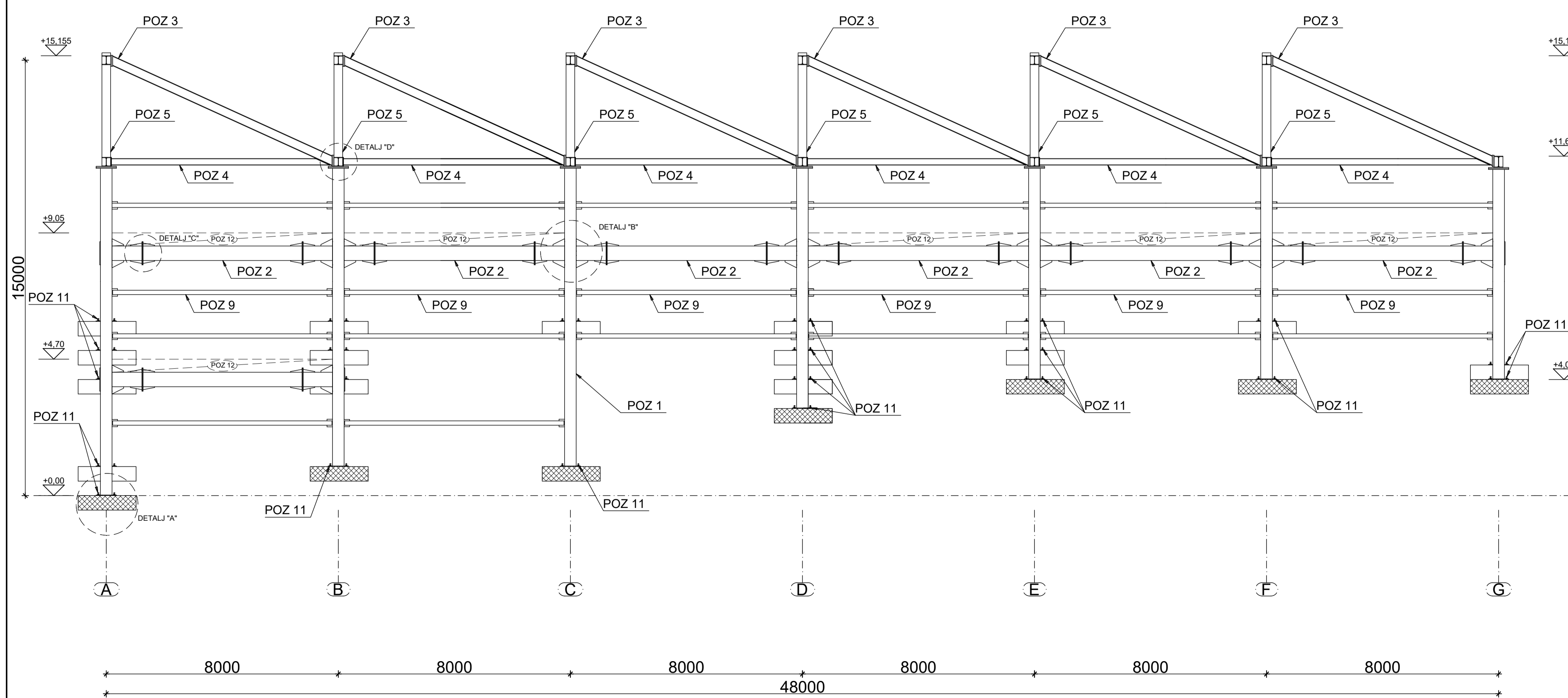

PLAN POZICIJA NOSIVE KONSTRUKCIJE

M 1:100

ČELIK S275  
BETON C 25/30

PRIKAZ I OPIS POZICIJA		
POZICIJA	PROFIL	NAZIV
POZ 1	RHS 400/10	Stup
POZ 2	RHS 500/300/13/13/10	Međukratna greda
POZ 3	HEA 320	Krovnna kosa greda
POZ 4	HEA 240	Horizontalna krovnna greda
POZ 5	HEA 320	Pojas krovnne rešetke
POZ 6	HEA 200	Vertikalna ispunna krovnne rešetke
POZ 7	HEA 180	Diagonalna ispunna krovnne rešetke
POZ 8	U 180	Krovnna podrožnica
POZ 9	RHS 150/5	Bočna podrožnica
POZ 10	RD 40	Sprej
POZ 11	2000/2000/500	TEME LJ SAMAC
POZ 12	10000/8000/45	Međukrata spregnuta konstrukcija

# DETALJ "A"

## Spoj stup-temelj

Remove Watermark Now

Tlocrt

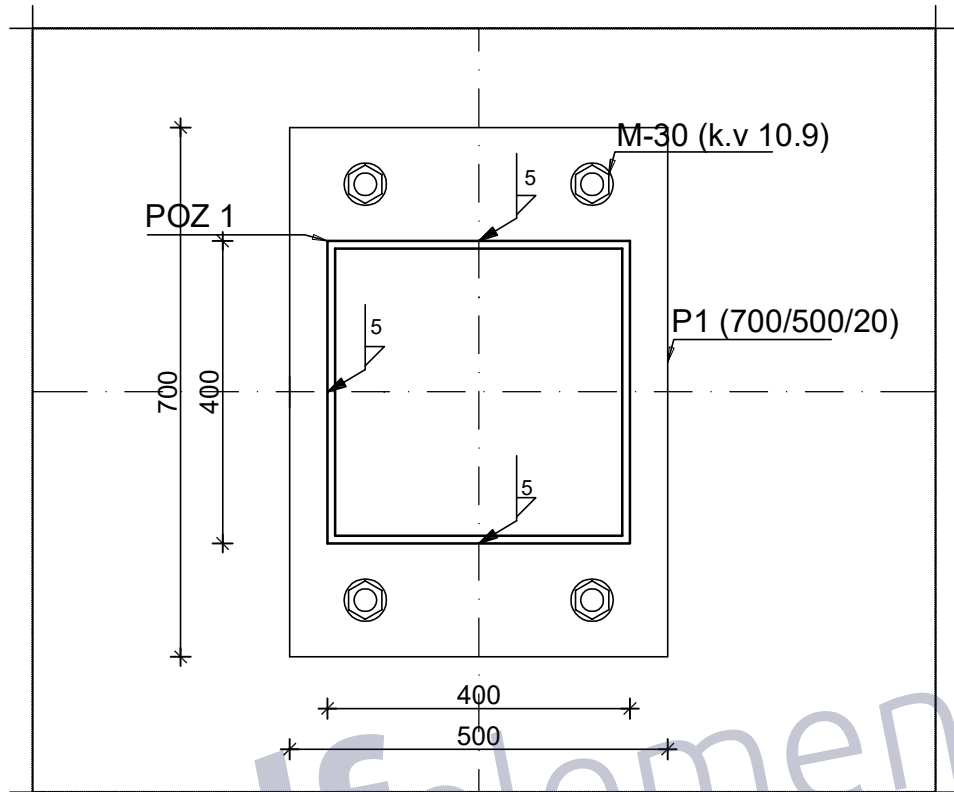

Pogled

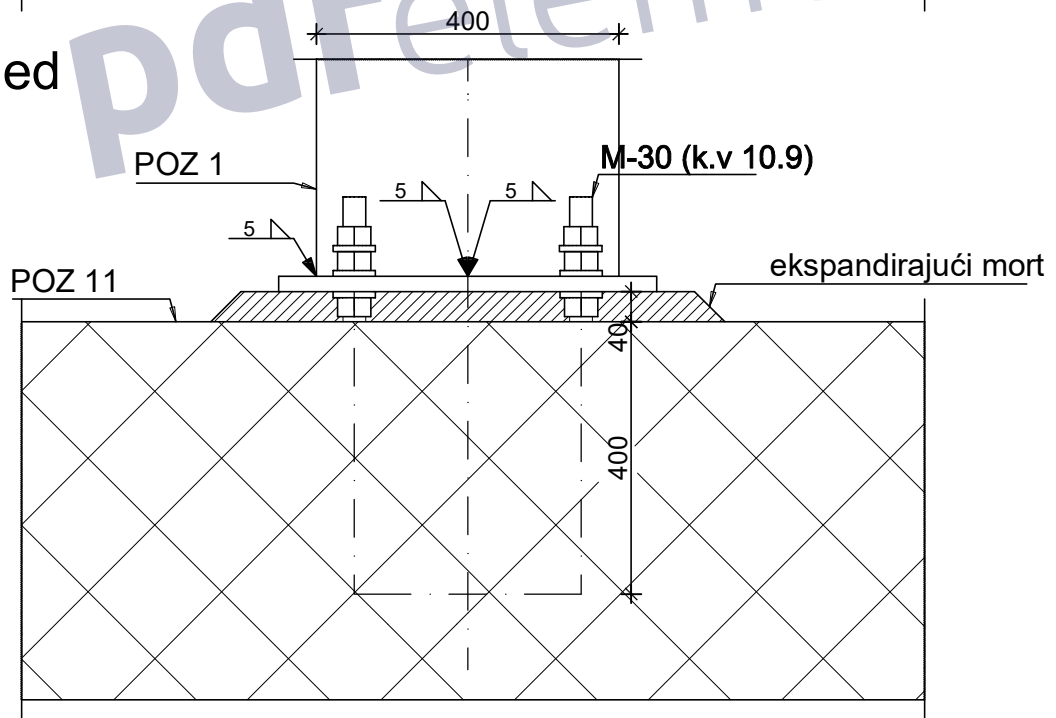

FAKULTET GRAĐEVINARSTVA, ARHITEKTURE I  
GEODEZIJE  
KATEDRA ZA METALNE I DRVENE KONSTRUKCIJE  
21000 SPLIT, MATICE HRVATSKE 15

DIPLOMSKI RAD

TEMA: KONSTRUKCIJA DRUŠTVENOG CENTRA  
MEJAŠI

STUDENT:  
Kojundžić Ivan, 587

MENTOR Prof. dr. sc. I. Boko

KOMENTOR dr. sc. N. Torić

SADRŽAJ DETALJ "A"

MJERILO 1:10

DATUM ožujak-lipanj 2017.

PRILOG 3

# DETALJ "B"

## Spoj stup-međukatna greda

Remove Watermark Now

Tlocrt

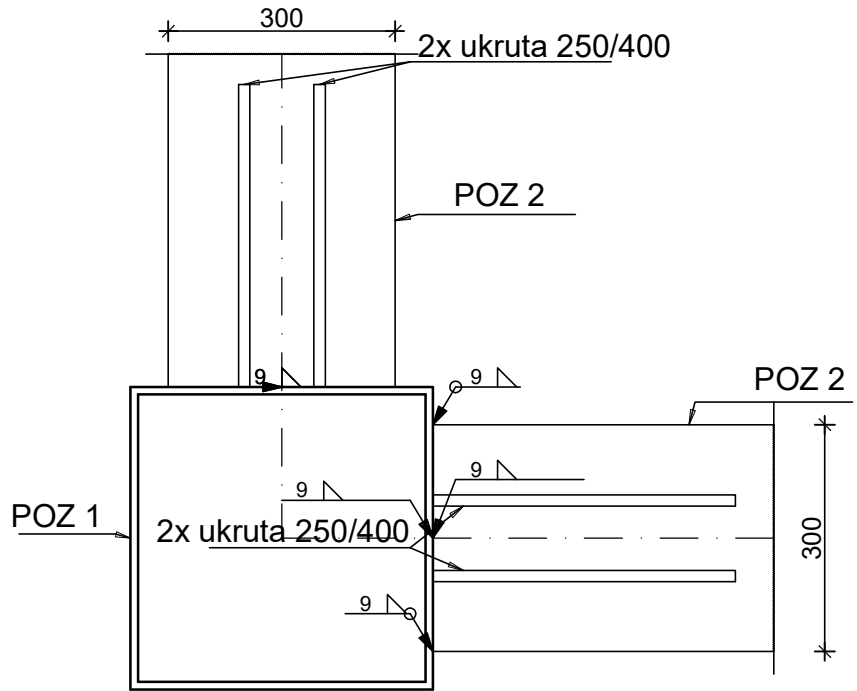

Pogled

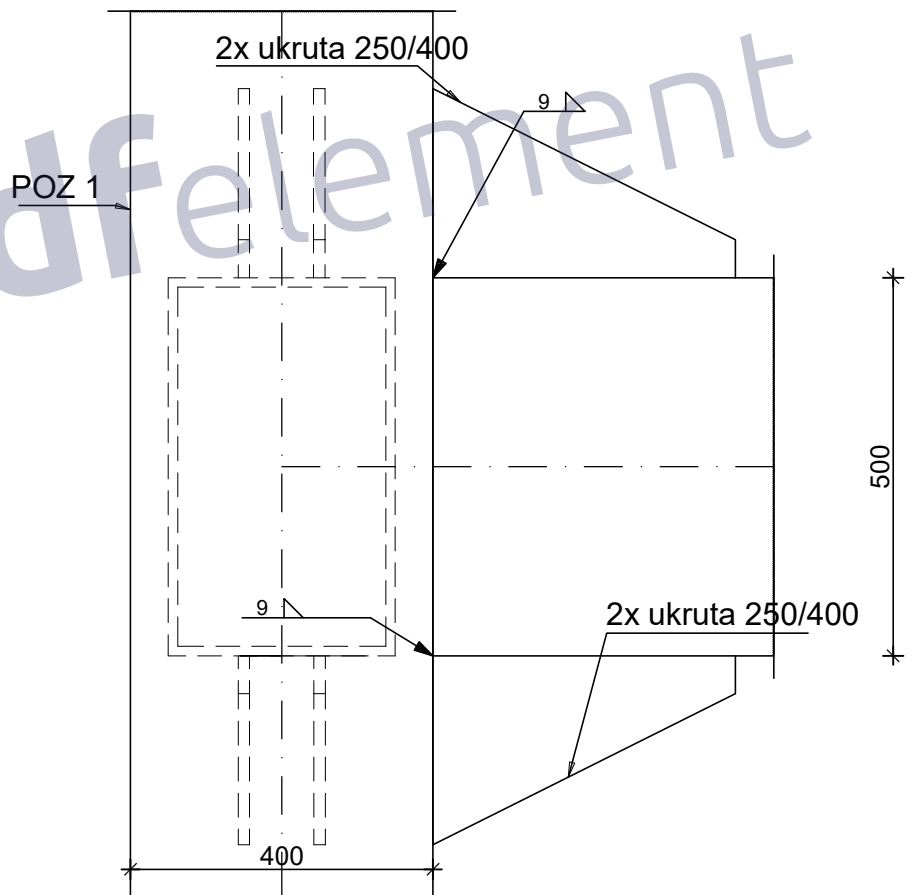

FAKULTET GRAĐEVINARSTVA, ARHITEKTURE I  
GEODEZIJE  
KATEDRA ZA METALNE I DRVENE KONSTRUKCIJE  
21000 SPLIT, MATICE HRVATSKE 15

### DIPLOMSKI RAD

TEMA: KONSTRUKCIJA DRUŠTVENOG CENTRA  
MEJAŠI

STUDENT:  
Kojundžić Ivan, 587

MENTOR  
Prof. dr. sc. I. Boko

KOMENTOR  
dr. sc. N. Torić

SADRŽAJ  
DETALJ "B"

MJERILO  
1:10

DATUM  
ožujak-lipanj 2017.

PRILOG  
4

# DETALJ "C"

## Nastavak međukatne grede

Remove Watermark Now

### Tlocrt

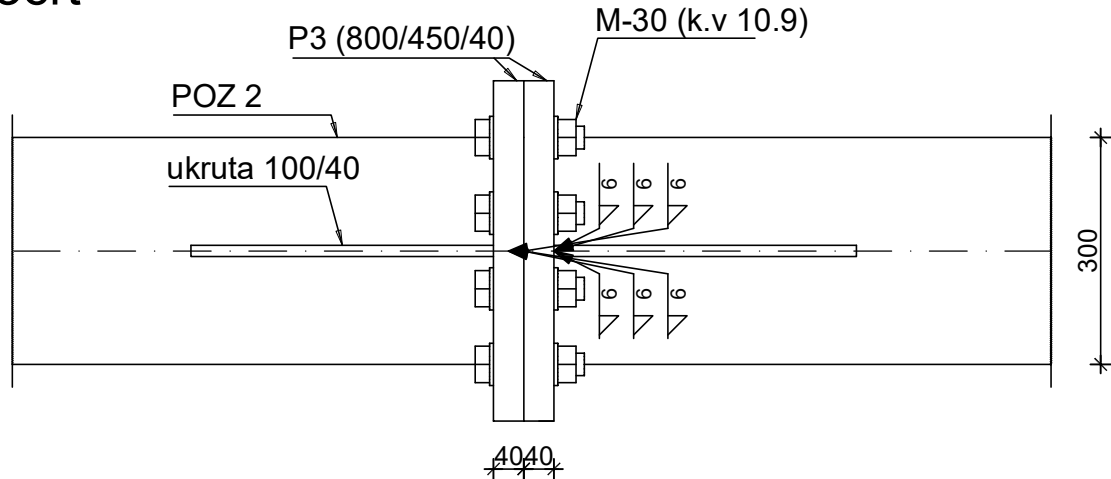

### Pogled

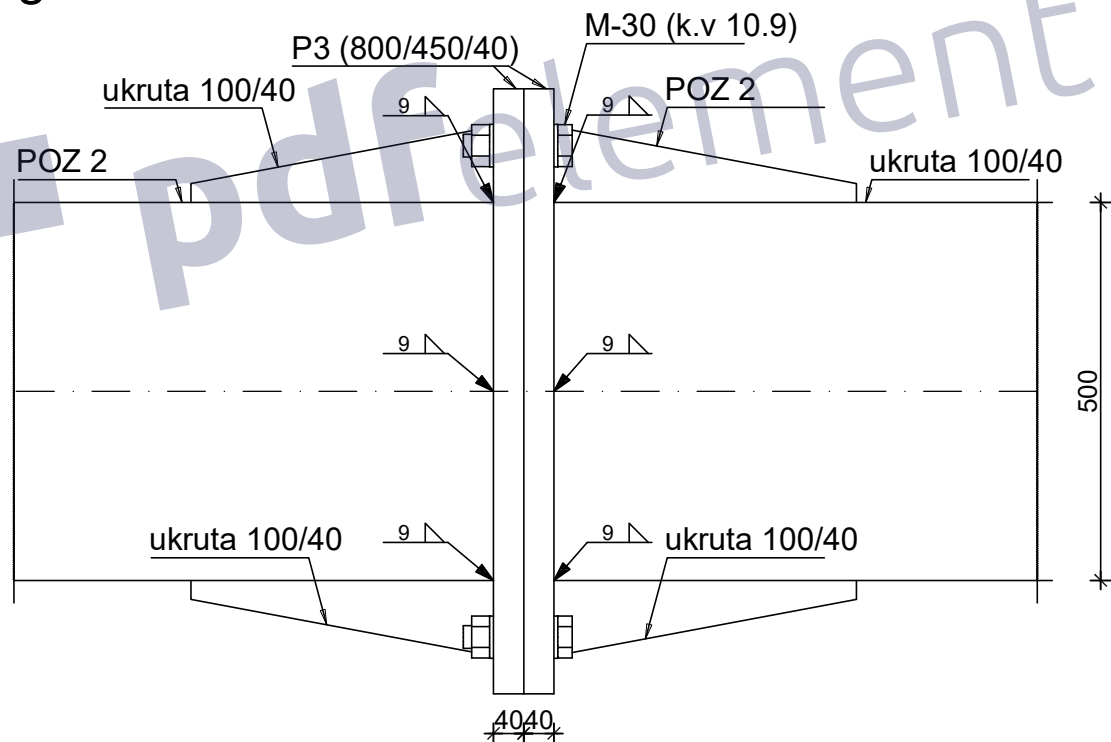

### DIPLOMSKI RAD

TEMA: KONSTRUKCIJA DRUŠTVENOG CENTRA  
MEJAŠI

STUDENT:  
Kojundžić Ivan, 587

MENTOR  
Prof. dr. sc. I. Boko

KOMENTOR  
dr. sc. N. Torić

SADRŽAJ  
DETALJ "C"

MJERILO  
1:10

DATUM  
ožujak-lipanj 2017.

PRILOG  
5



Tlocrt

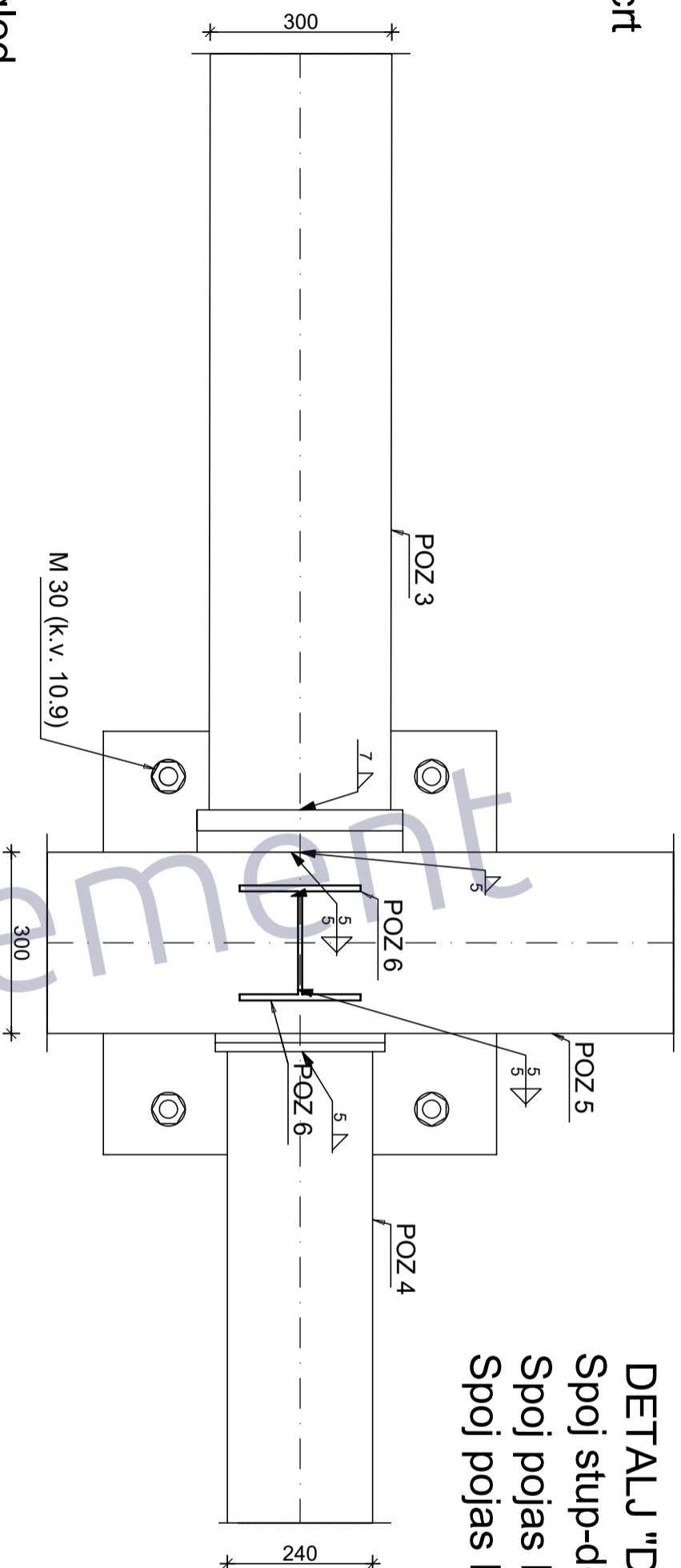

**DETALJ "D"**  
 Spoj stup-donji pojas krovne rešetke  
 Spoj pojas krovne rešetke-kosa krovna greda  
 Spoj pojas krovne rešetke-horz. krovna greda

Pogled

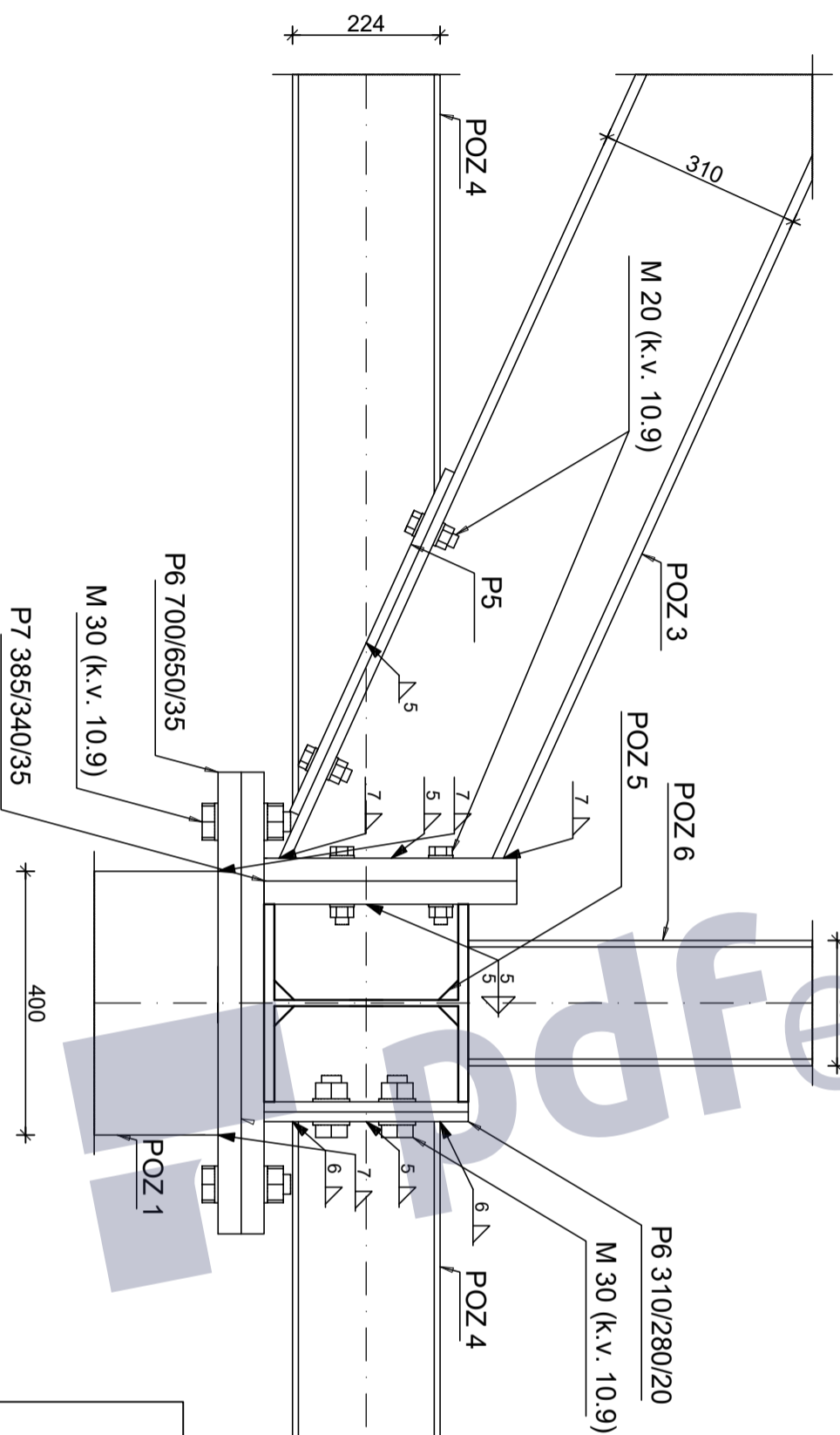

Napomena:  
 Sve dimenzije su mm.

DIPLOMSKI RAD

PROGRAMI: KONSTRUKCIJA DRUŠTVENOG CENTRA

MEJAŠI

STUDENT: Kojundžić Ivan, 587

MENTOR: Prof. dr. sc. I. Bokro

KOMENTOR: dr. sc. N. Torić

SAHRŽAJ: DETALJ "D"

MAJERLO: 1:10

PRILOG: 6

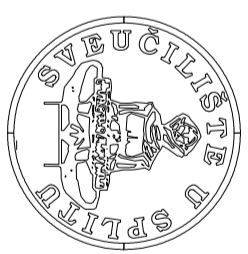

FAKULTET GRAĐEVINARSTVA, ARHITEKTURE I  
 KATEDRA ZA METALNE I DRVENE KONSTRUKCIJE  
 21000 SPLIT, MATICE HRVATSKE 15

# DETALJ "E"

## Spoj stup-bočna podrožnica

Remove Watermark Now

Tlocrt

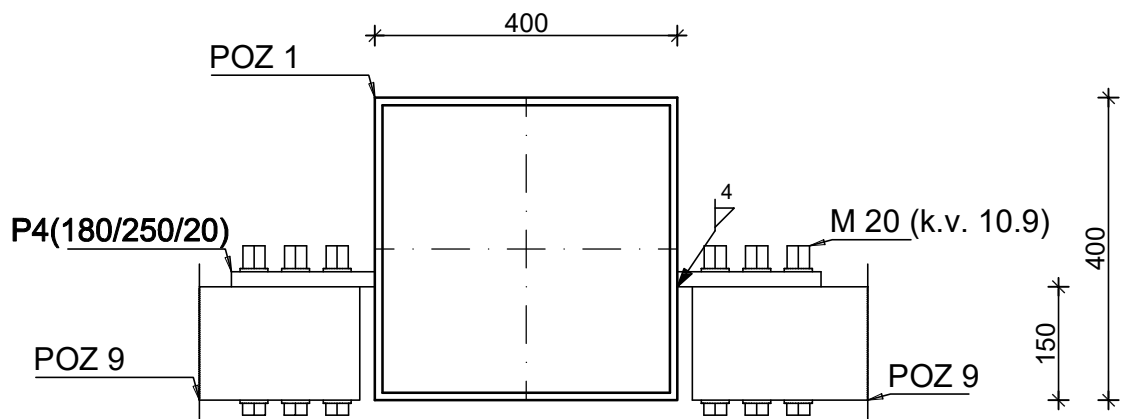

Pogled

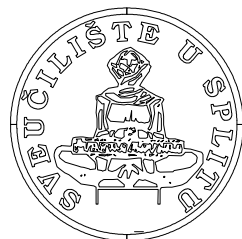
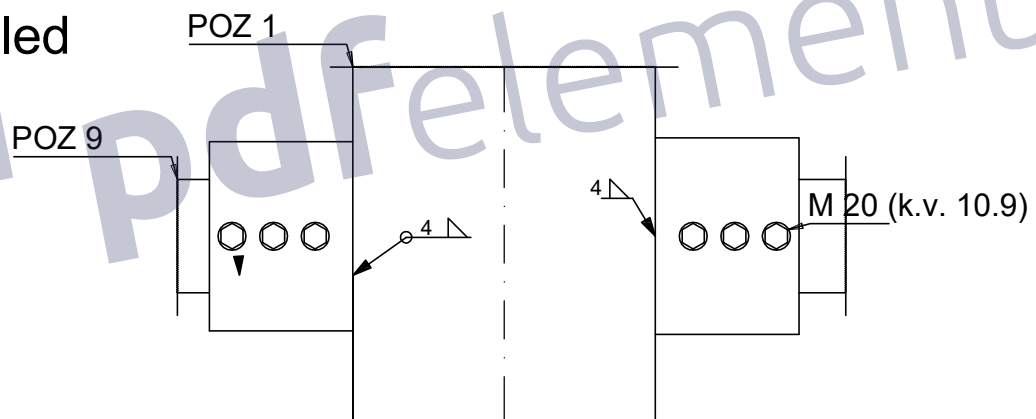

FAKULTET GRAĐEVINARSTVA, ARHITEKTURE I  
GEODEZIJE  
KATEDRA ZA METALNE I DRVENE KONSTRUKCIJE  
21000 SPLIT, MATICE HRVATSKE 15

DIPLOMSKI RAD

TEMA: KONSTRUKCIJA DRUŠTVENOG CENTRA  
MEJAŠI

STUDENT:  
Kojundžić Ivan, 587

MENTOR  
Prof. dr. sc. I. Boko

KOMENTOR  
dr. sc. N. Torić

SADRŽAJ  
DETALJ "E"

MJERILO  
1:10

DATUM  
ožujak-lipanj 2017.

PRILOG  
7

# DETALJ "F"

## Spoj stup-spreg

### Tlocrt

Remove Watermark Now

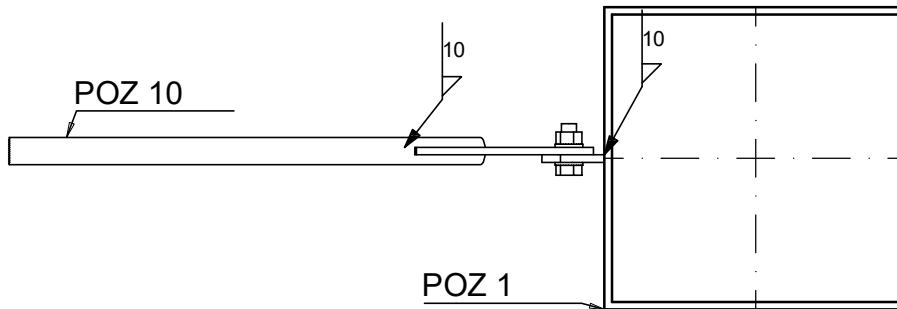

### Pogled

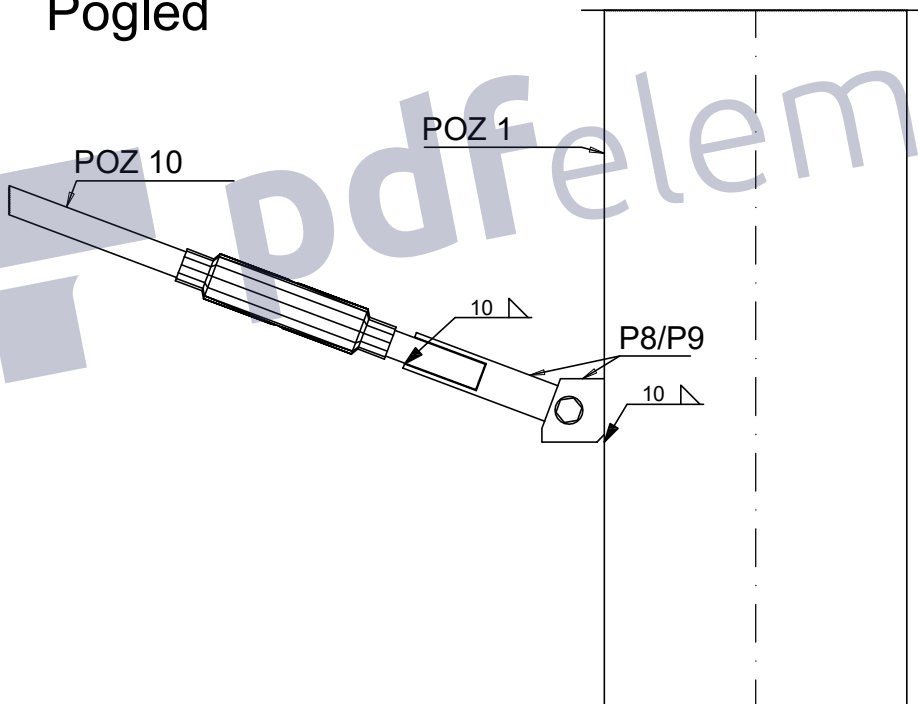

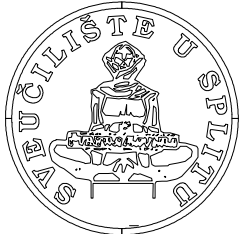
 <p>FAKULTET GRAĐEVINARSTVA, ARHITEKTURE I GEODEZIJE KATEDRA ZA METALNE I DRVENE KONSTRUKCIJE 21000 SPLIT, MATICE HRVATSKE 15</p>	<b>DIPLOMSKI RAD</b>	
	TEMA: <b>KONSTRUKCIJA DRUŠTVENOG CENTRA MEJAŠI</b>	
	STUDENT: <b>Kojundžić Ivan,587</b>	MENTOR <b>Prof. dr. sc. I.Boko</b>
		KOMENTOR <b>dr.sc. N.Torić</b>
	SADRŽAJ <b>DETALJ "F"</b>	MJERILO <b>1:10</b>
DATUM <b>ožujak-lipanj 2017.</b>	PRILOG <b>8</b>	

# DETALJ "G"

## Nastavak pojasa rešetke

### Tlocrt

Remove Watermark Now

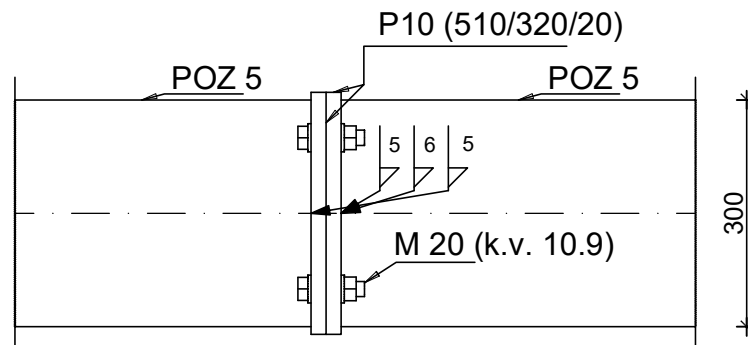

### Pogled

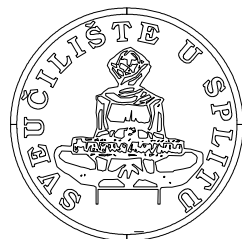
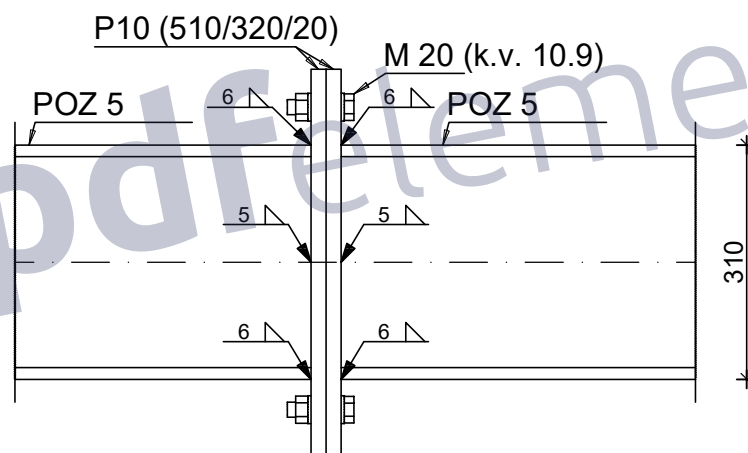

FAKULTET GRAĐEVINARSTVA, ARHITEKTURE I  
GEODEZIJE  
KATEDRA ZA METALNE I DRVENE KONSTRUKCIJE  
21000 SPLIT, MATICE HRVATSKE 15

### DIPLOMSKI RAD

TEMA: KONSTRUKCIJA DRUŠTVENOG CENTRA  
MEJAŠI

STUDENT:  
Kojundžić Ivan, 587

MENTOR  
Prof. dr. sc. I. Boko

KOMENTOR  
dr. sc. N. Torić

SADRŽAJ  
DETALJ "G"

MJERILO  
1:10

DATUM  
ožujak-lipanj 2017.

PRILOG  
9

# DETALJ "H"

## Nastavak pojasa rešetke

### Tlocrt

Remove Watermark Now

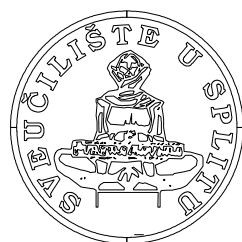
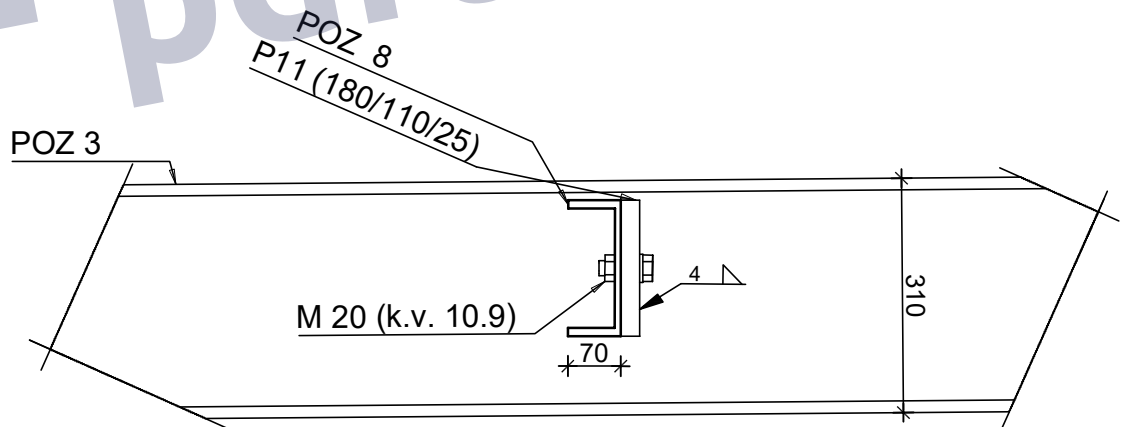
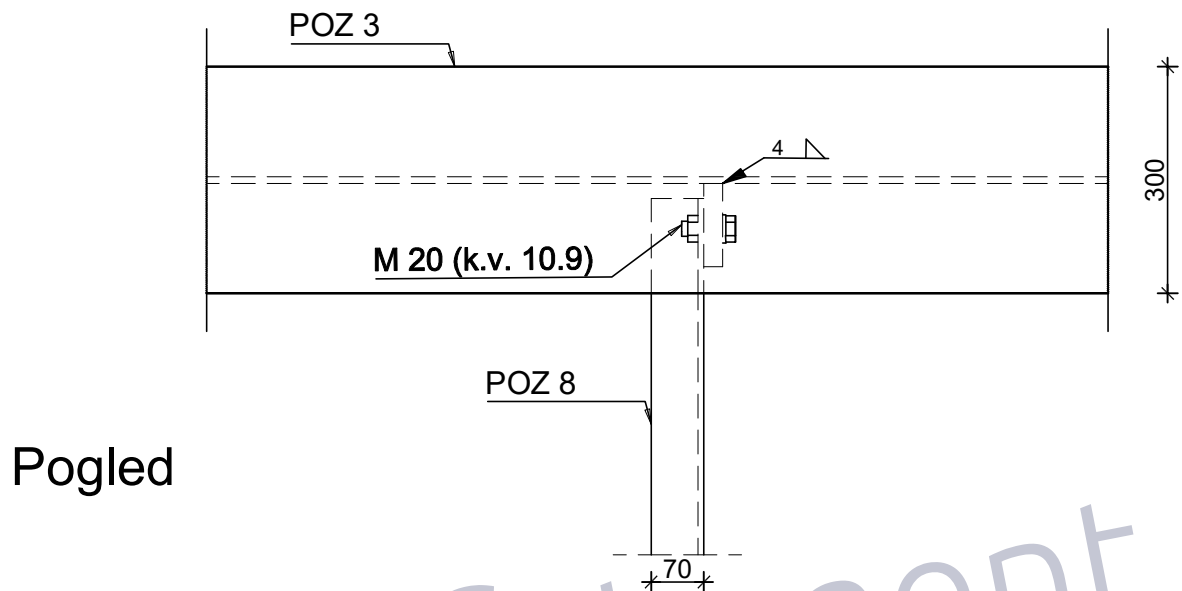

FAKULTET GRAĐEVINARSTVA, ARHITEKTURE I  
GEODEZIJE  
KATEDRA ZA METALNE I DRVENE KONSTRUKCIJE  
21000 SPLIT, MATICE HRVATSKE 15

#### DIPLOMSKI RAD

TEMA: KONSTRUKCIJA DRUŠTVENOG CENTRA  
MEJAŠI

STUDENT:  
Kojundžić Ivan, 587

MENTOR  
Prof. dr. sc. I. Boko

KOMENTOR  
dr. sc. N. Torić

SADRŽAJ  
DETALJ "H"

MJERILO  
1:10

DATUM  
ožujak-lipanj 2017.

PRILOG  
10

## 10. LITERATURA

- [1] Androić, Dujmović, Džeba, Metalne konstrukcije 1, IGH Zagreb, 1994.
- [2] Androić, Dujmović, Džeba, Metalne konstrukcije 2; IA Projektiranje Zagreb, 1995.
- [3] Androić, Dujmović, Džeba, Metalne konstrukcije 3, IA Projektiranje, Zagreb, 1995.
- [4] Androić, Dujmović, Lukačević, Projektiranje spregnutih konstrukcija prema Eurocode 4, IA Projektiranje, Zagreb, 2012

 pdfelement