

# Kružni (o)tok

---

**Petković, Marin**

**Supplement / Prilog**

*Publication year / Godina izdavanja:* **2020**

*Permanent link / Trajna poveznica:* <https://urn.nsk.hr/urn:nbn:hr:123:378989>

*Rights / Prava:* [In copyright](#)/[Zaštićeno autorskim pravom.](#)

*Download date / Datum preuzimanja:* **2024-12-19**



*Repository / Repozitorij:*

[FCEAG Repository - Repository of the Faculty of Civil Engineering, Architecture and Geodesy, University of Split](#)



UNIVERSITY OF SPLIT

  
DIGITALNI AKADEMSKI ARHIVI I REPOZITORIJI

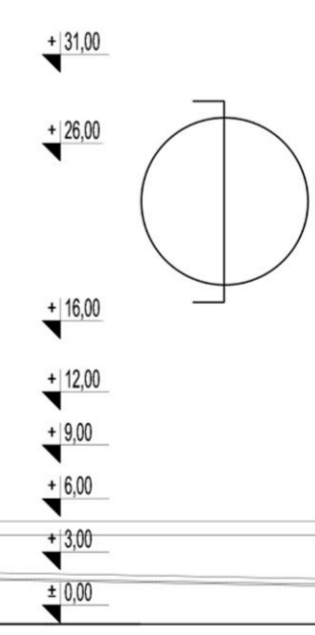
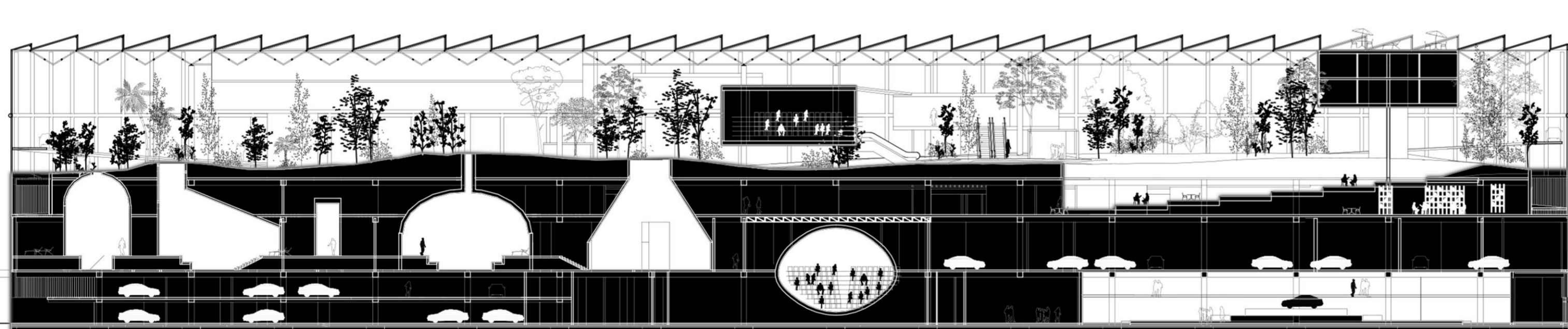
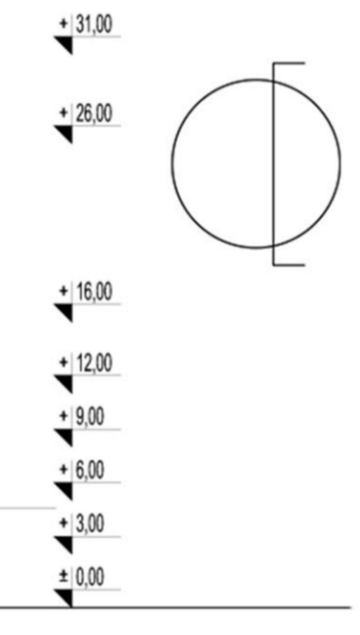
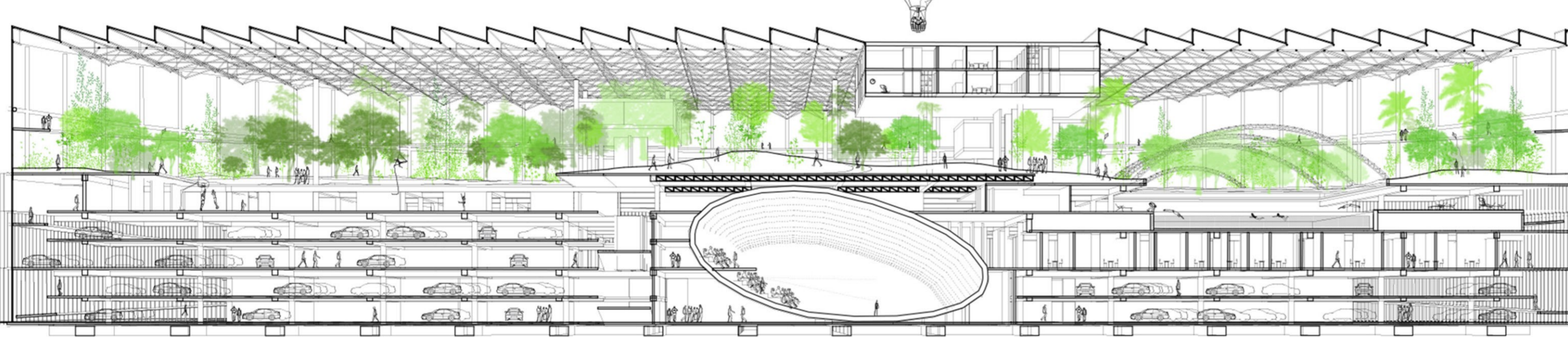
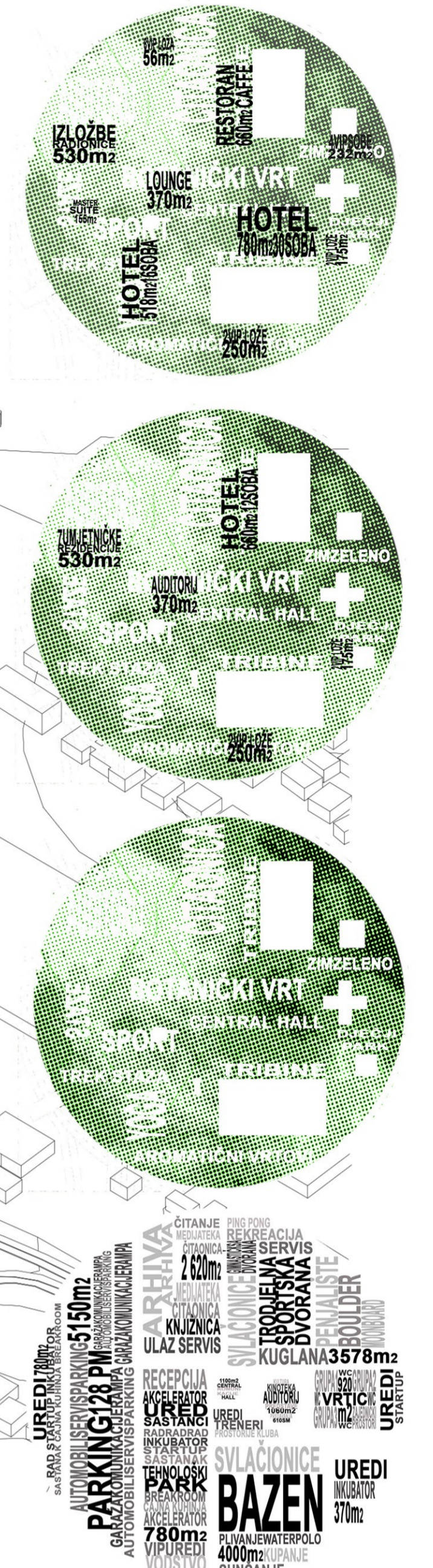
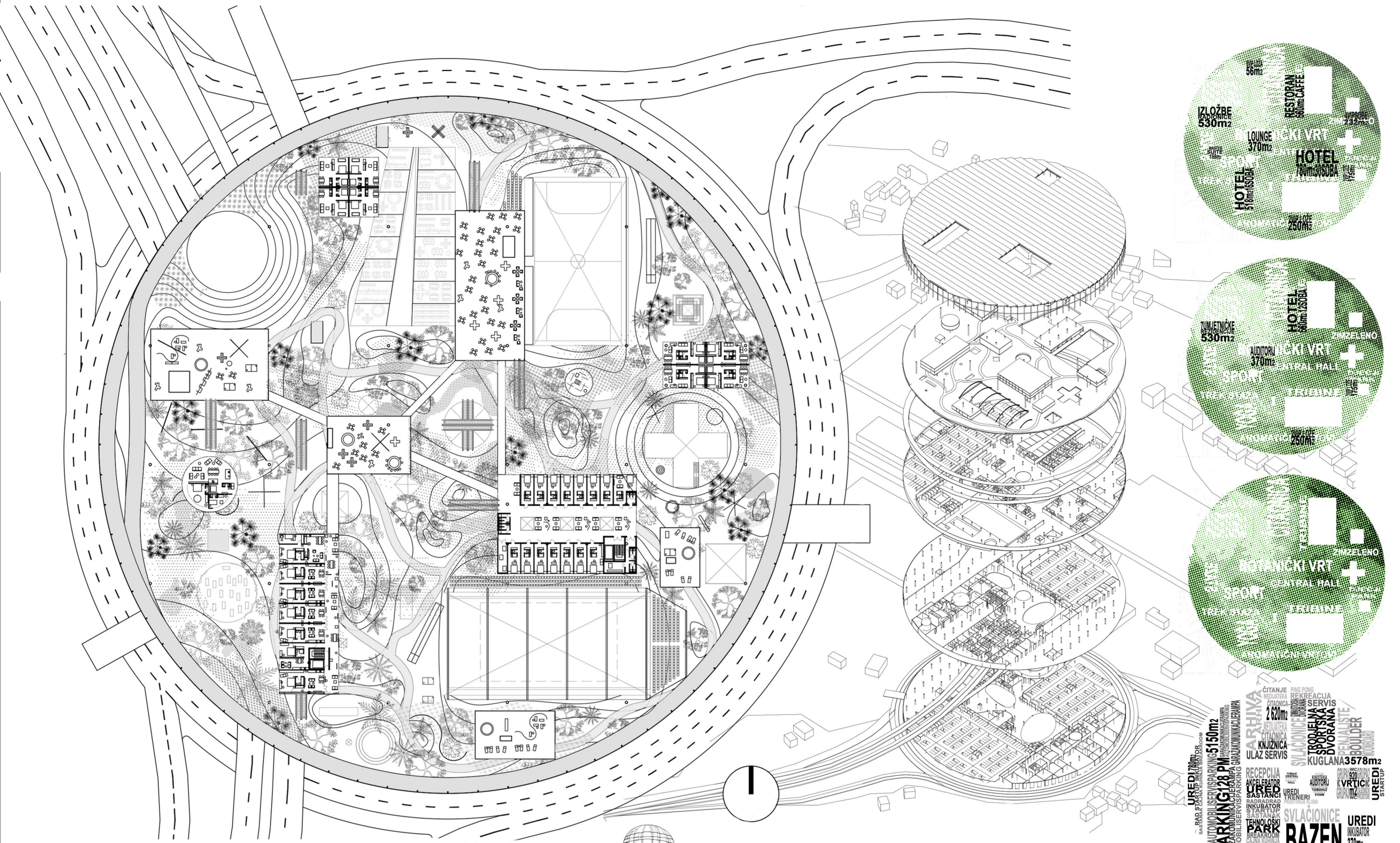

IME I PREZIME  
NASLOV DIPLOMSKOG RADA  
AKADEMSKA GODINA  
MENTOR  
KOMENTOR  
KONZULTANT

MARIN PETKOVIĆ  
KRUŽNI(O)TOK  
2019 / 2020  
izv.prof.TOMA PLEJIĆ d.i.a.  
dr.sc.SANJA MATIJEVIĆ  
BARČOT d.i.a.  
dr.sc.NENO TORIĆ d.i.g.

Rad istražuje odnos arhitekture i infrastrukture, ispituje površine izgubljene infrastrukturom, pitajući se kako kružni tok može postati kružni otok koji u sebe naseljava prostore rada i stvaranja, kao i rekreacije, kulture, učenja i botaničkog parka. Time nastaje centar kreacije i rekreacije - suprotnost zatvorenim shopping centrima fokusiranu konzumerizmom. "Privatno" i "javno" zgrade se međusobno nadopunjuje i gradi, nadopunjujući prostore koji fale gradu- bazeni, knjižnice, vrtić, wellness, auditoriji, muzej kao i laboratoriji, tehnološki centar, uredi, kreativna industrija, itd. Ovime se lokacija pretvara iz nedostupne točke kraj koje su svi prošli, a na kojoj nitko nije bio, u generator grada koji postaje svojevrsne kopča Splita, Solina i okolice.

