

Diskretna optimizacija ovješnih mostova

Derek, Andrea

Master's thesis / Diplomski rad

2015

Degree Grantor / Ustanova koja je dodijelila akademski / stručni stupanj:

University of Split, Faculty of Civil Engineering, Architecture and Geodesy / Sveučilište u Splitu, Fakultet građevinarstva, arhitekture i geodezije

Permanent link / Trajna poveznica: <https://um.nsk.hr/um:nbn:hr:123:880997>

Rights / Prava: [In copyright](#)/[Zaštićeno autorskim pravom.](#)

Download date / Datum preuzimanja: **2024-11-24**



Repository / Repozitorij:

[FCEAG Repository - Repository of the Faculty of Civil Engineering, Architecture and Geodesy, University of Split](#)



UNIVERSITY OF SPLIT



SVEUČILIŠTE U SPLITU
FAKULTET GRAĐEVINARSTVA, ARHITEKTURE I
GEODEZIJE

DIPLOMSKI RAD

Andrea Đerek

Split, 2015.

SVEUČILIŠTE U SPLITU
FAKULTET GRAĐEVINARSTVA, ARHITEKTURE I
GEODEZIJE

Andrea Đerek

Diskretna optimizacija ovješnih mostova

Diplomski rad

Split, 2015.



Diskretna optimizacija ovješnih mostova

Sažetak:

Ovješni mostovi su vrlo zahtjevne konstrukcije kod kojih se rasponski sklop ponaša kao kontinuirana greda elastično pridržana pomoću zakrivljenih kabela. Predstavljaju estetski privlačno i učinkovito strukturno rješenje za srednje do velike raspone i naširoko se upotrebljavaju širom svijeta. Ponašanje ovih konstrukcija određeno je krutošću nosivih elemenata (piona, rasponskog skolpa i vješaljki) i prijenosu sile u vješaljkama.

Projektiranje ovješnih mostova je iterativni proces u kojem projektant mora zadovoljiti sve kriterije povezane sa sigurnošću, upotrebom i cijenom mijenjajući određene strukturne parametre. U slučaju ovješnih mostova projekt mosta uključuje rješavanje velikog broja različitih problema kao što su odabir konstrukcijskog sustava, nelinearnost, proces izgradnje, ponašanje konstrukcije pod dinamičkim opterećenjem, itd.

Projekt takve konstrukcije generira veliku količinu informacija za vrijeme analize i projektiranja. Optimizacijski algoritam može uključivati kao projektirane varijable mehanička, geometrijska i sekcijeska svojstva. Tako, one mogu biti upotrijebljene u procesu projektiranja za određivanje poprečnog presjeka strukturnih elemenata i/ili određivanje sile prednapinjanja u kabelima za dobivanje optimalne duljine i visine stupova i raspona.

Većina metoda za dobivanje optimalnog rješenja pretpostavlja da su projektirane varijable kontinuiranog tipa. Općenito, projektanti su ograničeni na odabir veličine elemenata iz diskretnog skupa dostupnih veličina i problem u ovom radu je riješen na takav način. Stroga diskretna optimizacija je NP-hard problem (eksponencijalno vrijeme vs polinomsko vrijeme za kontinuiranu optimizaciju) značajni teža nego za kontinuirani problem.

U ovom radu prikazana je strukturna analiza i diskretna optimizacija ovješnih mostova. Kao optimizacijska metoda upotrijebljena je segmentalna optimizacijska metoda za dobivanje optimalnih dimenzija poprečnog presjeka ploče i piona te konačne sile u vješaljkama.

Ključne riječi:

Ovješni mostovi, diskretna optimizacija, segmentalna optimizacijska metoda



Discrete optimum design of cable-stayed bridges

Abstract:

Cable-stayed bridges are highly redundant structures in which the deck behaves like a continuous beam elastically supported by the inclined stays. They represent an aesthetically appealing and efficient structural solution for medium-to-long spans and are widely used all over the world. Their behaviour is governed by the stiffness of the load-bearing elements (pylons, deck and cable stays) and the cable force distribution.

The structural design of cable-stayed bridges is iterative process in which designers have to satisfy all criteria's relating to safety, use, economy, by changing certain structural parameters. In case of cable-stayed bridges the design of bridge includes solving a lot of different problems such as the choice of structural system, nonlinearity, construction process, dynamic behaviour, etc.

Project of such structures generated massive amount of information during analysis and design process. The optimization algorithm can include as design variables mechanical, geometrical and sectional properties. Thus, they can be widely used in design process from dimensioning of cross-sections of structure elements though determine of prestressing force of cables to obtain optimal length and height of towers and spans.

Most of the methods for the optimum design of engineering structures make the assumption that member size variables are continuous. Generally, designers are restricted to choosing member sizes from a discrete set of commonly available sizes and this problem is solved here. The rigorous discrete optimum design is a NP-hard problem (exponential time vs polynomial time for continuous optimization) significantly more difficult than the continuous problem.

In this work it is presented structural analysis and discrete optimization of concrete cable-stayed bridge. As optimization method is used segmental optimization method to obtain optimal dimensions of deck and tower cross-section and adjustment cable forces.

Keywords:

Cable-stayed bridges, discrete optimization, segmental optimization method



STUDIJ: **SVEUČILIŠNI DIPLOMSKI STUDIJ**

SMJER: **KONSTRUKCIJE**

KANDIDAT: **Andrea Đerek**

BROJ INDEKSA: **0443**

KATEDRA: **Katedra za Betonske konstrukcije i mostove**

PREDMET: **Mostovi**

ZADATAK ZA DIPLOMSKI RAD

Tema: Diskretna optimizacija ovješanih mostov

Opis Zadatka: Na temelju dobivenih vrijednosti proračuna ovješanog mosta pomoću kontinuirane optimizacije potrebno je izvršiti diskretizaciju dobivenih vrijednosti traženih parametara. Upotrebom segmentalne optimizacijske metode potrebno je odrediti optimalne dimenzije poprečnog presjeka ploče i pilona te konačne sile u vješaljka.

U Splitu, rujan 2015.

Voditelj diplomskog rada:

Prof. dr. sc. Alen Harapin

Predsjednik povjerenstva za
diplomske ispite:

Prof. dr. sc. Ivica Boko

Ovaj diplomski rad je izrađen na Fakultetu Znanosti i Tehnologije, Sveučilišta u Coimbri, Portugal.



FCTUC DEPARTAMENTO DE ENGENHARIA CIVIL
FACULDADE DE CIÊNCIAS E TECNOLOGIA
UNIVERSIDADE DE COIMBRA

Discrete optimum design of cable-stayed bridges

Dissertation submitted for the degree of Master of Civil Engineering in Structures

Author

Andrea Đerek

Supervisor

Luís Miguel da Cruz Simões

Coimbra, July, 2015.

Table of Contents

Acknowledgement.....	i
List of Figures	ii
List of Tables.....	iii
Abbreviation.....	iv
List of Symbols	v
Chapter 1. Introduction	1
1.1. General Task.....	1
1.2. Thesis overview	3
1.3. Thesis organization.....	3
Chapter 2. Literature review.....	5
2.1. Introduction	5
2.2. Historical review.....	5
2.3. Structural conception.....	12
2.3.1. Longitudinal conception.....	12
2.3.2. Anchoring system.....	15
2.3.3. Geometry of pylons	17
2.3.4. Geometry and materials of deck.....	17
2.4. Modelling of concrete structures	22
2.5. Geometrical nonlinear effects	24
2.6. Construction methods	24
2.6.1. Construction on temporary supports	25
2.6.2. Construction by rotation.....	25
2.6.3. Construction by incremental launching.....	26
2.6.4. Construction by cantilever method	26
2.7. Optimization of cable-stayed bridges	27

2.7.1. Optimization of cable force	27
2.7.2. Optimization of sectional and geometrical variables	29
2.7.3. Linear programming	32
Chapter 3. Optimum design formulation.....	35
3.1. Introduction	35
3.2. Design variables	37
3.3. Design objectives.....	38
3.4. Objective function	40
3.5. Sensitivity analysis	42
3.6. Segmental optimum design	44
Chapter 4. Numerical example and results.....	46
4.1. Description of numerical model	46
4.2. Design variables	47
4.3. Optimum design results	49
Chapter 5. Conclusions	55
References	56

Acknowledgement

I would like to express my gratitude to my teacher Prof. Alen Harapin for his courses and his interest and support of his students. As a main part of this thesis was developed through a student exchange program Erasmus + at the University of Coimbra, I thank him deeply for supporting me in my decision to accept this opportunity to visit, live and study in Portugal. I also appreciate his providing advice and support throughout my work on this thesis.

Furthermore, I would like to express my sincere thanks to Prof. Luís Miguel da Cruz Simões for acceptance to be my mentor here in Coimbra. I greatly appreciated that I could learn much from his rich experience in the construction field. My life has been enriched by his delightful storytelling.

I would like to express my sincere appreciation to Alberto Miguel Bizarro Martins for helping me on my work.

Also, I would like to thank all my new friends which I met in Portugal. I am really grateful what I have chance to meet you all. I will keep them in good remembrance.

Finally, and most importantly, I am most grateful for the continuous love and support that my family and friends in Croatia have always given me, during my work on this thesis and before.

List of Figures

Figure 2.1 – Bridge over the Tweed river

Figure 2.2 – Brooklyn Bridge

Figure 2.3 - Strömsund Bridge

Figure 2.4 - Bridge of Lake Maracaibo

Figure 2.5 – Tatara Bridge

Figure 2.6 – Sutong Bridge

Figure 2.7 – Russky Bridge

Figure 2.8 – Transmission of forces

Figure 2.9 – Vasco da Gama Bridge

Figure 2.10 – Barrios De Luna Bridge

Figure 2.11 – Bridge Rainha Santa Isabel

Figure 2.12- Viaduct de Millau

Figure 2.13 - Arrangement of cable stays in longitudinal direction

Figure 2.14 – Scheme of deck cross-section of the Brotonne Bridge

Figure 2.15 – Scheme of deck cross-section of Pasco-Kennewick Bridge

Figure 2.16 – Scheme of deck cross-section of Barrios Luna Bridge

Figure 2.17 – Scheme of deck cross section of Skarnsund Bridge

Figure 2.18 – Scheme of deck cross-section of Vasco da Gama Bridge

Figure 2.19 - Scheme of the cross section of the deck of Diepoldsau Bridge

Figure 2.20 – Construction on temporary supports

Figure 2.21 – Construction by cantilever method

Figure 3.1 – Scheme of optimization process

Figure 3.2 - Conventional member and segmental member

Figure 4.1 - Geometry of cable-stay bridge

Figure 4.2 – Zones for the cross-section design variables

Figure 4.3 - Cross-sectional geometry of the bridge elements

Figure 4.4 – Evolution of the bridge cost vs number of iterations

Figure 4.5 – Deck vertical displacements (continuous and discrete solutions after cable adjustment)

Figure 4.6 – Deck normal stresses (continuous and discrete solution after cable adjustment)

List of Tables

Table 2.1 The 10 longest cable-stayed bridges

Table 4.1 Material properties

Table 4.2 Design variables (single-cell box examples)

Table 4.3 Initial values of design variables

Table 4.4 – Cable installation forces (initial, final continuous and discrete values)

Table 4.5 – Sizing design variables (initial, final continuous and discrete values)

Table 4.6 – Cable adjustment forces (initial, final continuous and for discrete sizing variables)

Table 4.7 – Deck, tower and stays costs

Abbreviation

ACI – American Concrete Institute

ASCE – American Society of Civil Engineers

EC2 – Eurocode 2

EN – European Norma

FCTUC – Faculdade de Ciências e Tecnologia da Universidade de Coimbra

FIB – International Federation of Concrete

IABSE – International Association for Bridge and Structural Engineering

IPQ – Instituto Português da Qualidade

LNEC – Civil Engineering National Laboratory

List of Symbols

Latin uppercase

A - influence coefficient matrix of forces on the risers

A_c - concrete cross sectional area

E_c - concrete tangent modulus

E_c (t₀) - concrete modulus at the age t₀ days

E_{ck} * - equivalent modulus of the concrete for the time interval Δt_k

E_{cm} - average value of the concrete's modulus of elasticity at 28 days of age

E_{cm} (t) - mean value of the concrete's modulus days at age t

RH - relative humidity of the environment (in %)

J (t, t₀) - fluency function

Latin lowercase

a_j - Dirichlet series coefficient approaching fluency function

f_{ck} - characteristic value of the tensile strength of concrete in compression at 28 days of age

f_{cm} - average value of tensile strength of concrete in compression at 28 days of age

f_{cm} (t) - mean value of the concrete compressive tensile strength at age t days

f_{ctm} - Average value of the concrete tensile strength to simple traction at 28 days of age

f_{ctm} (t) - mean value of the concrete breaking tensile strength at age t days

h₀ - Equivalent thickness (mm) of a cross-section concrete element

kh - EC2 coefficient of shrinkage depends on the model and of equivalent thickness h_0

s - coefficient which depends on the type of cement

t - time, the concrete age

t_0 - concrete age, in days, the loading date

$t_{0,corr}$ - concrete age, in days, the date of loading corrected depending on the type of cement

t_0, T - concrete age, in days, the date of loading corrected for temperature

TS - concrete age in days at the start of drying shrinkage (or expansion) normally corresponds to the end of the cure

u - perimeter of the exposed part of the drying section

Greek case

Δt - time interval

ΔT_i - vector containing the variations of the values of the forces on the risers in the iteration i

$\epsilon_{ck} \Delta$ - incremental creep deformation for the time interval Δt_k

$\Delta \sigma(t, t_0)$ - variation of tension between the age t_0 and t

Greek lowercase

α - coefficient which intervenes in the formula of evolution with time of tensile strength of the concrete;

$\alpha_1, \alpha_2, \alpha_3$ - coefficients of EC2 creep model that depend on the concrete strength

$\alpha_{sd1}, \alpha_{sd2}$ - coefficients of EC2 retraction model and depending on the type of cement

$\beta(f_{cm})$ - Factor taking into account the influence of the concrete strength in creep coefficient is agreed 1

$\beta(t_0)$ - factor taking into account the influence of age of the concrete at the time of loading the creep coefficient

$\beta_{as}(t)$ - EC2 coefficient of shrinkage depends on the model and t in days old concrete, reflecting the evolution of autogenous shrinkage with time

$\beta_c(t, t_0)$ - coefficient that reflects the evolution of fluency in time

$\beta_{cc}(t)$ - coefficient which depends on the age of the concrete t

$\beta_{ds}(T, t_s)$ - EC2 shrinkage coefficient of the model and which depends on t , t_s and h_0 , representing the evolution of the drying shrinkage with time

β_{RH} - coefficient EC2 streaming model that depends on the relative humidity of the environment and h_0

γ_j - state variable reflecting the influence of the history of tensions on the deformation ϵ_c fluency

$\sigma(t, t_0)$ - extension of mechanical origin in the concrete t days of age due to a voltage applied at the age t_0

$\epsilon_c(t)$ - extension concrete at age t in days

ϵ_{ca} - retracting extension autogenous

$\epsilon_{ca}(\infty)$ - autogenous shrinkage extension to infinite time

ϵ_{cc} - fluency extension

$\epsilon_{cc}(t, t_0)$ - creep extension t to the concrete days of age due to a voltage applied at the age t_0

ϵ_{ccj} - j -th contribution term of Dirichlet series for the deformation of fluency

ϵ_{cd} - drying shrinkage extension

ϵ_{cd0} - nominal value of free shrinkage on drying

$\epsilon_{ci}(t_0)$ - extension instant t_0 to the concrete days of age

$\epsilon_{cn}(t)$ - extension on independent concrete stress state to t ϵ_{cs} days of age (t) - Total length of shrinkage in concrete to t days old

$\epsilon_{cT}(t)$ - extension of the concrete due to thermal action days old to t

η_{cj} - viscosity coefficient

λ_{jk} - Dirichlet series coefficient approaching fluency function in the time Δt_k

σ_0 - initial voltage

$\sigma_c(t_0)$ - tension in the concrete age t_0 days

$\varphi(\infty, t_0)$ - concrete creep coefficient at infinite time

$\varphi(t, t_0)$ - concrete creep coefficient at age t for a voltage applied at the age t_0

φ_0 - φ nominal flow coefficient

$\psi(t, t_0)$ - concrete relaxation coefficient at age t to an imposed deformation at the age t_0

Chapter 1. Introduction

1.1. General Task

Cable-stayed bridges are highly redundant structures in which the deck behaves like a continuous beam elastically supported by the inclined stays. They represent an aesthetically appealing and efficient structural solution for medium-to-long spans and are widely used all over the world. Their behaviour is governed by the stiffness of the load-bearing elements (pylons, deck and cable stays) and the cable force distribution.

The cable-stayed bridges made of structural concrete are efficient for spans of 400-500 m. For spans from 500 to about 700 m, the concrete deck is heavy and only-steel deck is expensive. Therefore the best solution for these spans is composite deck. Advantages of composite deck are reduction of the concrete self-weight and greater strength than in steel deck. At spans beyond 700 m only economical solution is steel girder with orthotropic deck. The towers are performed in concrete with only variation in material of the tray, which can be made of steel, concrete or mixture of steel-concrete. Recently the bridges Stonecutters Bridge in Hong Kong, Sutong Bridge in China and Russky Bridge in Russia were built with longest span more than 1000 m. Russky Bridge has central span of 1044 m and it is currently bridge with world largest central span. Concrete has high compressive strength and therefore is ideal for transmission of high compressive force introduced by inclined cables to foundations.

The structural design of cable-stayed bridges is iterative process in which designers have to satisfy all criteria's relating to safety, use, economy, by changing certain structural parameters. In case of cable-stayed bridges the design of bridge includes solving a lot of different problems such as the choice of structural system, nonlinearity, construction process, dynamic behaviour, etc.

Project of such structures generated massive amount of information during analysis and design process. Therefore, mathematical programming techniques were imposed as natural solution for automate this process. The structural optimization is not widely used in civil engineering but for large structures, such as cable-stayed bridges, the optimization techniques are important due the impact in cost reduction of materials, obtaining economical and safety

structure. The optimization algorithm can include as design variables mechanical, geometrical and sectional properties. Thus, they can be widely used in design process from dimensioning of cross-sections of structure elements though determine of prestressing force of cables to obtain optimal length and height of towers and spans.

Most of the methods for the optimum design of engineering structures make the assumption that member size variables are continuous. Generally, designers are restricted to choosing member sizes from a discrete set of commonly available sizes and this problem is solved here. The rigorous discrete optimum design is a NP-hard problem (exponential time vs polynomial time for continuous optimization) significantly more difficult than the continuous problem. The rounding process turns out to be a combinatorial problem of considerable size even for the simplest of such structures. The continuous optimum design forms a lower bound to the discrete optimum and it is usually assumed that the continuous sizes should be somehow rounded up or down to discrete sizes, consequently providing a good starting design for a discrete solution of low weight. The continuous optimum design variables are rounded up or down to the nearest available discrete sections to find a discrete solution which may be unfeasible. This solution is then improved by optimizing the cable installation forces (continuous variables) to meet the stress and displacements criteria. If this solution remains unfeasible, the segmental method which uses linear programming is adopted to find the sizing variables which need to be modified.

The application of optimization algorithms for the project of cable-stayed bridges was studied by several authors. All that work considered or cable forces (installation or adjustment) or cross-section dimensions mostly of steel bridges. For concrete cable-stayed bridges studies are rare and do not include particular issues connected with the analysis of construction phases or distribution of the forces and displacement of concrete elements. Also time effects of concrete are not included.

In this work it is presented structural analysis and discrete optimization of concrete cable-stayed bridge. As optimization method is used segmental optimization method to obtain optimal dimensions of deck and tower cross-section and adjustment cable forces.

1.2. Thesis overview

Due to the high degree of indeterminacy of cable-stayed structures, an extensive degree of understanding for both design and construction is required. In comparison to other types of conventional bridges, cable-stayed bridges demand sophisticated structural analyses and design techniques.

With an optimized adjustment of the cable forces, it is possible to achieve an “ideal state”, at which the girder and the pylon are compressed with little bending only. The “ideal state” of a cable-stayed bridge is associated with the minimized total bending energy accumulated along the girder. This results in a possible design of slender decks. The materials for the deck and the pylons can be efficiently utilized.

With an optimization of cross-section dimensions it is accomplished reduce of self-weight of cable-stayed bridge elements (deck and pylon) which has influence on level of the displacements and stresses of deck and pylon. Also with optimization it is possible to reduce amount of material of bridge elements.

In this thesis was considered optimization of deck and pylon cross-section and adjustment forces of cable stays. All design variables were taken as discrete design variables. For determination of optimal design variables was used segmental method. Results are obtained solving multi-objective function using linear programming in MATLAB.

1.3. Thesis organization

This thesis consists of four chapters, shortly described in following text.

Chapter 1 of this thesis contains introductory information. It provides the reader with overview of structural and optimization analysis of concrete cable-stayed bridges.

Chapter 2 covers literature review relating to study traces of bridges, in particular of concrete bridges performed. Start with the historical background of cable-stayed bridge construction, outlining the developments of this type of bridge in last decades and gives the salient examples for each era. Different erection procedures are also outlined. It should be a review of the major works in relation to the two major themes of this work, structural analysis and optimization of concrete cable-stayed bridges.

Chapter 3 contains structural analysis of concrete cable-stayed bridge and description of optimization process including all necessary steps in that process. Also in this chapter are described goals which have to be reached with optimization.

Chapter 4 describes numerical example of on specific concrete cable-stayed bridge and results with conclusion obtained with optimization. In final chapter is given bibliography references.

Chapter 2. Literature review

2.1. Introduction

In this chapter is showed state of knowledge related to the theme of these thesis particularly concrete cable-stayed bridges. This type of structures was already described in several works (Gimsing, 1997; Podolny and Scalzi, 1986; Troitsky 1988; Walther et al, 1999). However, these structures are very complex and for better understanding problems designers encounter in their work, this thesis is divided in sub-chapters. Each sub-chapter describe one specific aspect of cable-stayed bridge or optimization process. First sub-chapter is a brief of historical review of construction of cable-stayed bridges. In second sub-chapter is presented general characteristics of structural function (transmission of forces) and typical structural types of various structural elements. After this follow reviews of previous work related to concrete cable-stayed bridges and optimization. They are divided in two themes which are developed in this thesis. First is analysis and second is structural optimization of cable-stayed bridges. At the end of this chapter is given summary of most important points of work.

2.2. Historical review

The history of stayed beam bridges indicates that the idea of supporting a beam by inclined ropes or chains hanging from a mast or tower has been known since ancient times. The Egyptians applied the idea for their sailing ships. In seventeen century was first introduced a bridge system having a timber deck supported by inclined eyebars by Verantius. His proposing contains the main features and basic principles of metal suspension bridge stiffened by stays. First attempt of build cable-stayed bridge was in Germany, by Immanuel Loscher in 1784. He designed a timber bridge with timber stays inclined in timber tower with span of 32 m. One more attempt was in 1817 with system of inclined chains which were adopted in a bridge built at Dryburgh Abbey across the Tweed River with span of 79.3 m.



Figure 2.1 –Bridge over the Tweed river (Wikipedia, 2015)

In nineteenth century appeared new kind of bridges design. That was hybrid system which is combination of cable-stayed bridges and classical suspension bridge. Examples of these bridges are the Franz Joseph Bridge, built in 1868 in Prague, Czech Republic, the Albert Bridge, built in 1873 at Chelsea, England. In these designs were evident lack of knowledge in calculation of bridges and lack of knowledge about behaviour of bridges which led to collapse of these bridges and postponed construction of this kind of structures.

Progress of using form of cable-stayed bridge happened in second half of nineteenth century in America by famous bridge designer Roebling where he used hybrid solution. He used inclined cables to decrease deformability of the deck. The Brooklyn Bridge in New York built in 1883, was example of this kind of bridge.



Figure 2.2 – Brooklyn bridge (www.boomsbeat.com, 2015)

First modern cable-stayed bridges built in concrete were in 1920s by Eduardo Torroja, aqueduct Tampul on the river Guadalete, in Spain and by Albert Caquot in 1952, Donzère Canal Bridge, in France. However, real development came from Germany with Franz Dischinger and with series of steel bridges across the river Rhine. Dischinger published studies of bridge construction in 1938, in which he proposed using high strength steel cables subjected to pre-initial efforts in order to increase their effective stiffness, thereby improving their suspension up effect (Billington and Nazmy, 1990; Virlogeux, 1999).

First modern metal cable-stayed bridge was the Strömsund Bridge in Sweden, designed by Dischinger in 1955. The bridge consists of three spans and has total length of 322 m and central span of 182,6 m. Deck is made of concrete and steel (composite deck) and the deck is supported by four pairs of inclined cables, one at each side of towers.



Figure 2.3 - Strömsund Bridge (de.wikipedia.org, 2015)

In following years, several innovation in constructing cable-stayed bridges were introduced in Germany across river Rhine. The Theodor Heuss Bridge was built in 1957. With a main span of 260 m, the bridge introduced harp-shaped cable system with parallel stays and free-standing pylon. Pylons with height of 40 m above the deck were made of reinforcement concrete and from that level were made with cantilever method. Next was the Severins Bridge, open for traffic in 1959, was the first application of A-shaped pylon combined with transversally inclined cable planes. Also this bridge was first one constructed as an asymmetrical two span bridge with one pylon positioned on one side of river banks. Next innovation was the Norderelbe Bridge in Hamburg which was first cable-stayed bridge with a central cable plan. Pylons and the stay cables were positioned in centre of motorway.

The Mannheim-Ludwigshafen Bridge across the Rhine built in 1972 was the first bridge with parallel-wire stays. Also this bridge introduces a new design concept. Main span, deck was made of steel, while the side spans were made of concrete.

The beginning of modern cable-stayed bridges was to a large extent dominated by steel bridges with orthotropic decks together with plate or box girders and cellular pylons. One of the innovations was given by Italian bridge designer Morandi who designed cable-stayed bridge with prestressed reinforcement concrete. His most significant work is bridge of Lake Maracaibo in Venezuela completed in 1962. Design of bridge is unique because bridge contains 5 main spans, each 235 m, with total length of 8678 m. each span is supported with 92 m tall tower and provides 46 m of clearance to the water below. It was first built multi-span cable stayed-bridge.



Figure 2.4 - bridge of Lake Maracaibo (Wikipedia, 2015)

One of examples superiority of cable-stayed bridges is bridge Tjörn Bridge. After ship collisions with pylon, original arch bridge was replaced with cable-stayed bridge. New bridge has main span of 366 m, which was 86 m longer than previous one. This bridge also belongs to the group of bridges which were built of different structural materials in the side and main spans. The side spans are built like continuous concrete girders with intermediate support at each cable anchored point and the main span is made like steel box with orthotropic deck.

Alex Fraser Bridge is example of advantages of using composite girder for long span cable-stayed bridges. Because of light steel girder, it was possible to use cantilever method for built this bridge. The cable stays were added before heavy concrete deck was made. The concrete deck is used to transfer compression which is introduced in girder by the horizontal component of stay force.

In 1983, it was finished bridge Barrios de Luna in Spain, designed by engineer Carlos Fernández Casado. With 440 m of central span it was world record with major central span at that time. Few years later, in 1986, the new record was accomplished with construction of the bridge Annacais in Vancouver (Canada) with central span of 465 m and composite deck with height of 2.215 m.

1990s has been years of remarkable progress of cable-stayed bridges where have been exceeded the barrier of 500 m of main span with Skarnsund Bridge and later also with Yangpu Bridge (Virlogeux, 1999). The Skarnsund Bridge, with 530 m of main span, is still bridge with biggest main span whose deck is made of concrete.

With construction of the Normandy Bridge (France, 1995 with 856 m of main span) and Tataru (Japan, 1998 with 890m of main span) the cable-stayed bridges entered in field of large span bridges.



Figure 2.5 – Tataru Bridge (http://www.ihl.co.jp/iis/english/products/bridge_cab.html, 2015)

In twenty-first century, with construction of the Stonecutters Bridge (Hong Kong, 2009 with main span of 1018 m) and Sutong (Shanghai, 2008 with main span of 1088 m) the previous world record were broken.



Figure 2.6 – Sutong Bridge (Wikipedia, 2015)

At present, Russky Bridge (Russia, 2012) is world largest cable-stayed bridge, with total length of 3100 m and main span with 1104 m. Pylons are inverted like A-shaped, with height of 320 m, constructed using custom self-climbing form. The span structure has an aerodynamic cross-section which has been determined based on aerodynamic design and optimized according to the results of experimental processing of scale model. Welded field connections are used for longitudinal and transversal joints of the cap sheet of the orthotropic plate and lower ribbed plate. For joints of vertical walls of the blocks, longitudinal ribs, transversal beams and diaphragms, field connections are used provided by means of high-strength bolts. The cable stayed system assumes all static and dynamic loads on the bridge deck. Cable stays are provided with maximum possible protection not only against natural disasters, but also against other adverse effects. The so-called “compact” PSS system has been implemented in the cable-stayed bridge deck; this advanced system differs by denser strands

allocation in the sheath. Design of cable stays, which employs sheaths and small diameter, reduced effect of wind load for 25-30%. Moreover, the cost of materials for pylons, the stiffening girder and foundations decreases by 35-40%. PSS cable stays consist of parallel strands of 15.7 mm diameter; every strand consists of 7 galvanized wires. Cable stays incorporate from 13 to 85 strands.



Figure 2.7 – Russky Bridge (<http://rusbridge.net/>, 2015)

In the last twenty years, cable-stayed bridges have developed to become dominating in bridge constructions with the span range from 200 m to 500 m. Under specific conditions, the cable-stayed bridges may even be a competition to suspension bridges up to spans more than 1000 m. Table 2-1 also shows that the girder in the main span is dominantly fabricated by steel and, up to a span of 600 m, also by composite sections.

Name	Longest span (m)	Pylons	Completed	Country
Russky Bridge	1104	2	2012	Russia
Sutong Bridge	1088	2	2008	China
Stonecutters Bridge	1018	2	2009	Hong Kong
E`dong Bridge	926	2	2010	China
Tatara Bridge	890	2	1999	Japan
Pont de Normandie	856	2	1995	France
Jiujiang Fuyin Expressway Bridge	818	2	2013	China
Jingyue Bridge	816	2	2010	China
Incheon Bridge	800	2	2009	South Korea
Xiamen Zhangzhou Bridge	780	2	2013	China

Table 2-1 shows the 10 longest cable-stayed bridges

2.3. Structural conception

Cable-stayed bridges are multiple statically undetermined structures. Behaviour of these structures is related with the stiffness of their main parts (deck, pylons, and cable-stays). Thus, in this part will be present most relevant aspect of these structures.

2.3.1. Longitudinal conception

Cable-stayed bridges are structures made of deck which is supported by inclined cables on one or more pylons. In this structures deck is behaved like continuous beam elastically supported in points where cables are anchored. Transmission of the forces is conducted according to following pattern: Deck transmits load to the pylon trough cables which are always in tension and pylons transmits that load to the foundations under mainly axial action.

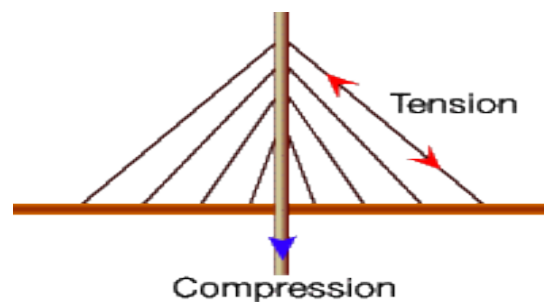

Figure 2.8 – Transmission of forces (<http://science.howstuffworks.com/engineering/civil/bridge.htm/printable>, 2015)

As was mentioned before, first built cable-stayed bridges had limited number of cable stays. According to that we had very small number of cables with large area of cable. That caused problems in the way of anchored the cable stays.

Thus, it was necessary to introduced multiple-suspension system of cable stays which used large number of cable stays with small spacing (between 7 to 15 m) and small diameter of stays. That system ensured continuous support of the deck. Bending moment of deck depends on gap between cable stays, use of small gap results in lower bending moment which allowed using stays with smaller diameter. In this case, the forces transmitted by cable stays are lower so it is possible to use smaller anchors and cables with smaller diameter. In the multiple-suspension solution can be used more slender cable stays, therefore lighter, easier to build and allowing the execution of larger spans. This solution has the further advantageous economic point of view because the bridge cable stays, as is disclosed in (Walther et al, 1999), increase the cost per m^2 of the board due to the gap is smaller than in any other type of bridge. This solution is adopted for cable-stayed bridges with small to medium spans. However, for bridges with medium to long spans it has been adopted one special system. That is system with two pylons and three spans. One main span and two side spans. Bridges with these kinds of spans are built entirely in steel, prestressed concrete and mixed of steel and concrete. To ensure that stress variation between main and side span is less than allowed stress it is usual to set that length of side spans is 40 % and 45 % of length of main span (Leonhardt, 1987).

For bridges with medium to large span exist few ways to design longitudinal concept. First one is using transition pillars in the side spans. The use of two or three intermediate side pillars will allow attenuating these stress variations. Example for this solution is presented on Figure 2.9.



Figure 2.9 – Vasco da Gama Bridge (<http://www.thelisbonconnection.com/>, 2015)

Second variant, unusual, is characterized by the adoption of very short side bays, with a length between 20% and 30% of the length of the central span. The ends of the deck are fixed, so it is necessary to adopt an expansion joint mid-span of the bridge to accommodate the axial deformation and rotations due to temperature variations and delayed effects of concrete. Example for this solution is presented on Figure 2.10.



Figure 2.10 – Barrios De Luna Bridge
(http://www.arqueologiaypatrimonioindustrial.com/2007_07_01_archive.html, 2015)

Another structural design adopted in the longitudinal arrangement of cable-stayed bridges is characterized by having only a tower. This solution is more widely used in small and medium span bridges. In this solution there is one main span offset of side span with intermediate pillars in which cables are anchored or a main span rigid with retaining cables attached to outer anchor block. Example for this solution is presented on Figure 2.11.

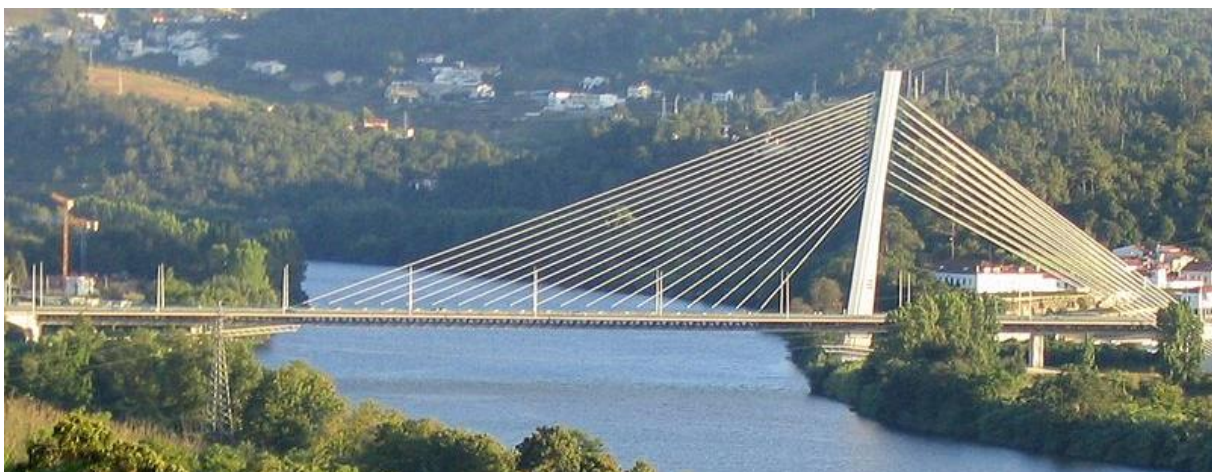

Figure 2.11 – Bridge Rainha Santa Isabel (Wikipedia, 2015)

The multi-span cable-stayed bridges can be considered as a third type of longitudinal configuration. Example for this solution is presented on Figure 2.12.



Figure 2.12- Viaduct de Millau (<http://circuitosvip.blogspot.pt/2015/01/viaduto-de-millau-franca.html>, 2015)

2.3.2. Anchoring system

Choice of anchoring system of cable-stayed bridges is one of most important steps in design of bridges. Anchoring system has great impact, not only on behaviour of structure, also on constructive process and cost of bridge because 20 % to 30 % of the total cost represents cost of anchoring system.

Arrangement of cable stays in longitudinal direction can be carried out like fan system, harp system or semi-harp system.

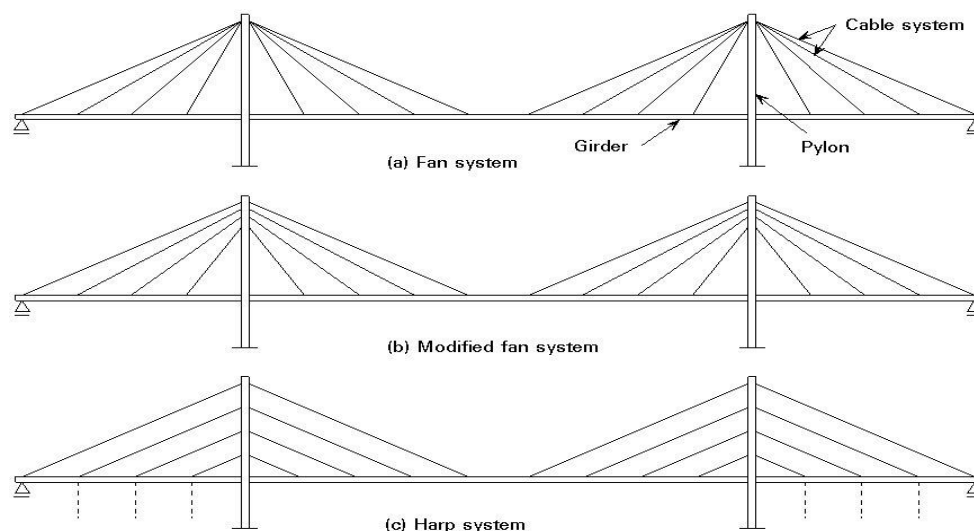

Figure 2.13 - Arrangement of cable stays in longitudinal direction (<http://www.fgg.uni-lj.si/>, 2015)

First built bridges with small to medium spans were built with fan system of anchoring of cable stays. Advantages of this system is that as greater angle of cable stay with horizontal plane is formed, lower installation force is needed and in principal, low total amount of cables. However, disadvantage of this system is that all cables have to anchor at the top of pylon which present construction problem and also pylon is loaded only on his top. In terms of service, there is possibility of imbalance of force transmitted by cable stays which lead to high bending moments at the base of bridge. Thus, although fan configuration is generally regarded as the most economical in terms of the amount of steel stays (Podoly and Scalzi, 1986; Troitsky, 1988) have not been frequently used in large cable-stayed bridges. Furthermore, this solution is generally considered less attractive from an aesthetic point of view due to the optical effect of crossing rods, depending on this aspect, however, the observer location (Walther et al, 1999).

Harp system of anchoring is characterized that all cable stays are parallel to each other. Advantages of this system are that the pylon has additional support along the whole height. Disadvantage of this system is that at lower height of pylon it is not economical solution because it require greater number of cable stays. However, this system represents aesthetically most recognized solution because it gives great regularity of structure. By observing the bridge cables obliquely intersect always at a constant angle (Walther et al, 1999).

With evolution of cable-stayed bridges and multiple-suspension systems it was required to developed system of anchoring which combine advantages of both systems. This system is characterized that cable stays are anchored to the certain point of pylon height. Thus, it allowed construction of cables relatively simple than in fan system and angle inclination is higher than in hap system. This arrangement of the cable stays has been progressively adopted in the construction of modern cable-stayed bridges because it establishes a balanced structural balance between operational requirements, economic and aesthetic.

In horizontal direction it is established anchoring in one or two planes, rare in three planes. The choice of number of anchoring planes depends of cross-section of deck and geometry requirements of pylons. Aesthetically better solution is to choose one plane anchoring system because during observing the bridge will never be crossing of cables. Furthermore, this solution required great torsional stiffness of deck cross-section because cables generated only vertical loads in this plane. This system can be used for box or multi-cell box cross-section of deck or if deck is monolithically connected with pylon.

Lateral suspension can be classified as partial or total. In partial suspension system deck is suspended by cable stay and also suspended in pylon. In case of total suspension, deck is suspended just with cable stays and that solution has several advantages from a structural point of view. The support made by partial suspension system is more rigid than one made by total suspension system therefore with total suspension system the values of negative bending moments of deck are much less than one in partial suspension system. Also from seismic point of view, with total suspension system structure act like pendulum suspended on cables with no significant efforts on displacement of pylons and foundations. Disadvantage of this system is high displacements of deck which are not important for road bridges but can be significant in rail bridges under acting of starting and breaking forces of composition of train.

2.3.3. Geometry of pylons

In principle the pylon is a tower structure where the most decisive load will be the axial force originating from the vertical components of the forces in the cables attached to the pylon. Nowadays, pylons are mostly built of concrete because the concrete towers are cheaper than steel once and also gives more freedom in shaping. Their height has great impact on amount of steel used for cable stays and level of compressive axial force in deck. Also height of the pylon above the tray is normally between 20% and 25% of the length of the central span, where two pylons are used, and when is just one pylon used the height of pylon is about 40% to 50% of the main span. (Leonhardt, 1987; Hewson 2003). Pylons can be shaped like A, H, X, inverted V, Y or combination of these.

The definition of the geometry of the pylons depends on anchoring systems (fan, harp or semi-harp) and suspension (lateral or central, partial or total) adopted. It is still necessary to also take into account the longitudinal configuration (bridge with three spans and two pylons; asymmetrical bridge with only one pylon and a main span, bridge multiple spans) and guarantee the space for anchoring and tensioning cable stays inside the pylon. In addition to these aspects, and because of the huge influence of the geometry of the pylons on the aesthetics of a bridge cable stays, usually the final configuration of the pylons is built on aesthetic considerations.

2.3.4. Geometry and materials of deck

The choice of deck cross-section has great impact on design of bridge. Choice of material will influenced on self-weight of deck, which will has impact on structural design of other parts of bridge. Shape of cross-section of deck depends also on aerodynamic behaviour of elements.

The structural purpose of the deck / stiffening girder is to carry longitudinal and transverse bending moments, bring stiffness to the bridge and distribute point loads to cables.

First modern cable-stayed bridges, had a reduced number of cable stays and limited distance between them, thus it was necessary to have relatively stiff deck made mostly of steel. Evolution in design of cable-stayed bridges brings greater number of cable stays and thus distance between them was not limited, which allowed using of thinner decks made of different materials. Bridge deck can be made of steel, reinforced concrete, prestressed concrete or can be made as composite deck (combination of steel and concrete). The self-weight of deck have direct influence on required capacity of pylon and cable stays. According to Walther et al. (1999) self-weight of decks are:

- Steel deck 2.5-3.5 kN/m²
- Composite deck 6.5-8.5 kN/m²
- Concrete deck 20 -25 kN/m²

The weight of deck has influence, not just on number of cable stays and distance between them, also dictate cross-section of pylons and amount of material which is required for pylons and stays. According to that, it is necessary to made cost benefit analysis to choose most economical solution.

Due to stiffness of concrete cross section and relatively small self-weight, the concrete deck is the most economical solution for spans to 400 m. For spans from 400 to about 700 m, the concrete deck is heavy and only-steel deck is expensive. Therefore the best solution for these spans is composite deck. Advantages of composite deck are reduction of the concrete self-weight and greater strength than in steel deck. At spans beyond 700 m only economical solution is steel girder with orthotropic deck.

The longitudinal bending moment depends also on weight of deck and distance between cable stays, so parameter of distance between cable stays is related to material of which deck is made. Thus, for concrete deck, distance between cable stays is from 6-9 m. for composite deck that parameter is from 9-16 m. for steel deck it can be used from 15-20 m.

Type of cross-section of deck in cable-stayed bridges depends on chosen suspended system (lateral or central). The central suspension required cell box cross-section. For the lateral suspension system can be used cross-section from beam-and-slab cross-section till multi-cell box cross-section.

In this part will be present some of solutions adopted for cross-section of deck of the cable-stayed bridges. The cell box cross-sections have not been used as optimal cross-section for bridges with central suspension system but also for the bridges with lateral suspension system. Case of central suspension system is Brotonne Bridge, whose cross-section of deck is presented on Figure 2.14. For the main span of 320 m it was used single-cell box cross-section made of prestressed reinforcement concrete. Dimensions of cross-section are 19.20 m wide and 3.80 high with inclined anchors, which help in transmission of forces.

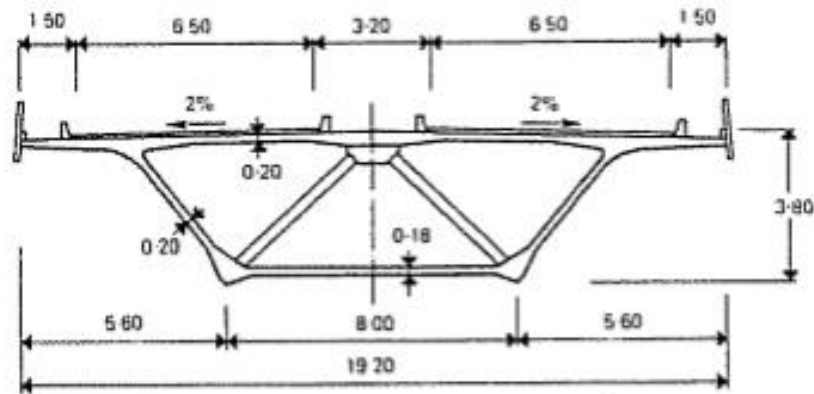

Figure 2.14 – Scheme of deck cross-section of the Brotonne Bridge (Walther et al, 1999)

In Pasco-Kennebec Bridge, with lateral suspension system, the deck has two web, trapezoidal box girder cross-section, trussed on the inside to refer the stay anchorage loads located in the centre of the upper slab to the bottom box girder angles. In the construction of this bridge are used all prefabricated elements to accelerate process of construction and eliminate effects of creep and shrinkage of concrete.

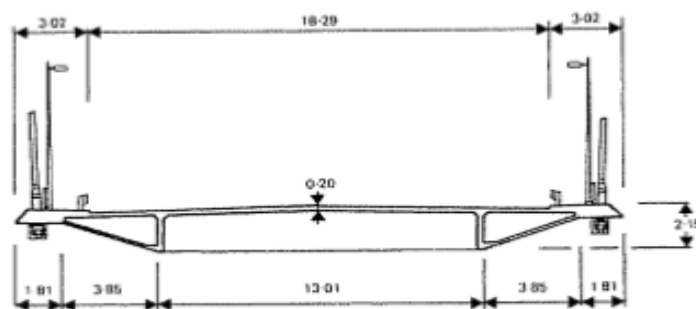

Figure 2.15 – Scheme of deck cross-section of Pasco-Kennebec Bridge (Walther et al, 1999)

On the bridge Barrios Luna, which also has lateral suspension system, was used tri-cell box cross-section. Dimension of cross-section are 22.5 m wide and 2.5 m high for main span of 440 m. Scheme of deck cross-section is presented on Figure 2.16.

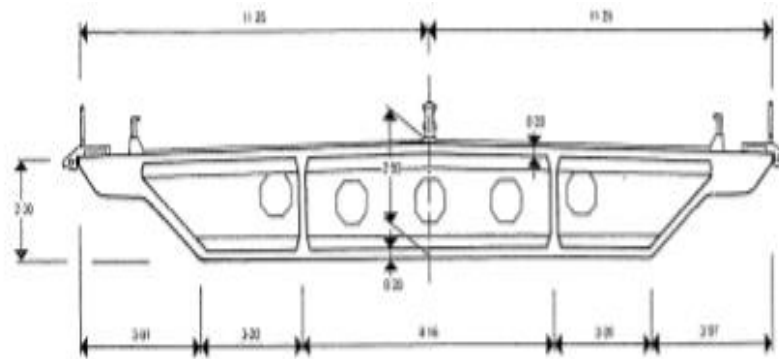

Figure 2.16 – Scheme of deck cross-section of Barrios Luna Bridge (Walther et al, 1999)

In the Skarnsund Bridge, which present today's biggest main span made of concrete, also was used cell box cross section with lateral suspension system. In this bridge was used triangular bi-cell box cross section with maximum height of 2.15 m with main span of 530 m.

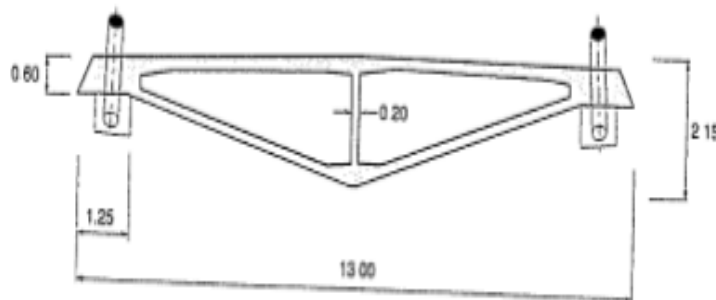

Figure 2.17 – Scheme of deck cross section of Skarnsund Bridge (Walther et al, 1999)

Except cell box cross-section in concrete cable-stayed bridges it is common to use slab cross-sections. This solution allows light and thin design solutions, combining this way economical and aesthetical part. In Figure 2.18 is presented, as an example, scheme of deck cross-section of Vasco da Gama Bridge in Lisbon. This deck is 30.90 m wide and it is made of one concrete slab with 0.25 m thickness which is supported on two longitudinal prestressed reinforcement concrete beams with 2.6 m high and 1.7 m wide and transversal beam spaced every 4.425 m. to reduce the weight of deck transversal beam was made of steel. Main span of this bridge is 420 m. Scheme of deck cross-section of Vasco da Gama is presented on Figure 2.18.

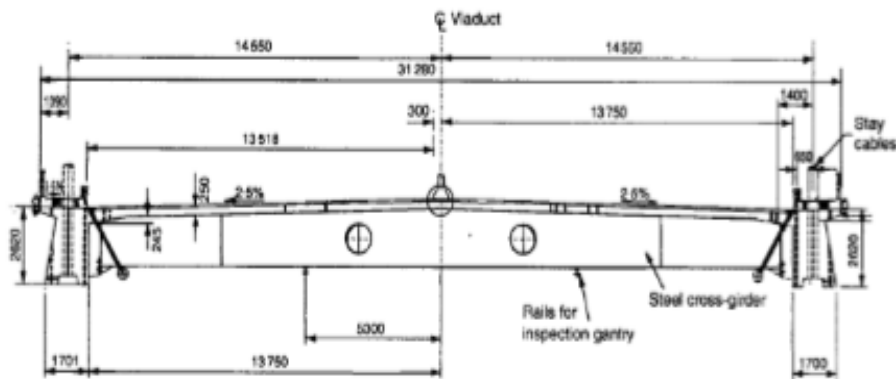

Figure 2.18 – Scheme of deck cross-section of Vasco da Gama Bridge (Hewson, 2003)

Taking full advantages of multiple suspension system it is possible to design solution with even more slender deck including into cross-section slender slab. As an example may be mentioned the solution adopted for the bridge deck of Diepoldsau Bridge in Switzerland, which is completed in 1985. This bridge has main span of 97 m and 14.5 m wide deck with slab of 0.45 m thickness. The deck is suspended by cable stays every 6 m.

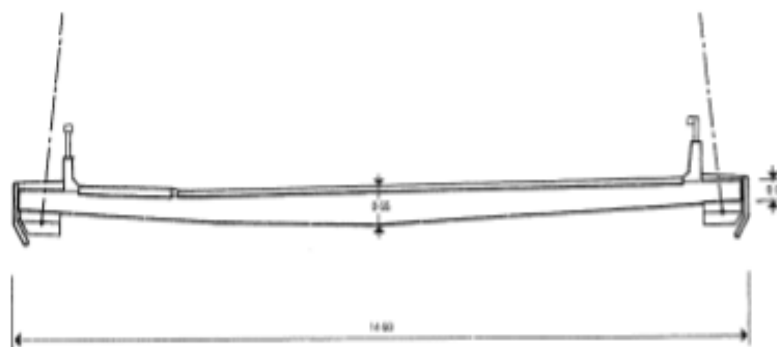

Figure 2.19 - Scheme of the cross section of the deck of Diepoldsau Bridge (Walther et al, 1999)

2.4. Modelling of concrete structures

In this study, the time-dependent effects of creep, shrinkage and aging of concrete are evaluated according with Eurocode 2 formulations. The creep model is based on linear viscoelasticity and takes into account ageing effects. Shrinkage strains are time-dependent but stress independent.

Concrete strength and modulus of elasticity increase with time as result of curing. At an early age, the strength and modulus of elasticity increase quickly and the increase then gradually stagnates but does not stop completely. According to Eurocode 2 the concrete modulus of elasticity at an age, t , in days is given by

$$E_{cm}(t) = \left(\exp \left\{ s \left[1 - \left(\frac{28}{t} \right)^{1/2} \right] \right\} \right)^{0.3} E_{cm} \quad (1)$$

where E_{cm} is the mean modulus of elasticity of concrete at an age of 28 days, t is the age of the concrete in days and s is a coefficient depending on the cement type.

The total strain at time t of a concrete specimen, uniaxially loaded with a stress σ_c at time t_0 , can be written as the sum of the stress dependent, $\varepsilon_{c\sigma}(t, t_0)$, and stress independent, $\varepsilon_{cn}(t)$, strains:

$$\varepsilon_c(t) = \varepsilon_{c\sigma}(t, t_0) + \varepsilon_{cn}(t) = J(t, t_0) \cdot \sigma_c(t_0) + \varepsilon_{cn}(t) \quad (2)$$

where $J(t, t_0)$ is the creep function and if the stresses are less than 45% of the characteristic value of concrete compressive strength (f_{ck}), the principle of superposition is valid and the creep strain varies linearly with the applied stress.

In a cable-stayed bridge the stresses continually change during both the construction phase and the service life of the structure. Under variable stresses and using the principle of superposition, Equation 2 can be rewritten as:

$$\varepsilon_c(t) = J(t, t_0) \cdot \sigma_c(t_0) + \int_{t_0}^t J(t, \tau) \frac{\partial \sigma_c(\tau)}{\partial \tau} d\tau + \varepsilon_{cn}(t) \quad (3)$$

Several approaches have been proposed to solve this equation, simplified methods, step-by-step numerical integration and approximation of the creep function. In this paper the creep function is approximated by a Dirichlet series leading to:

$$J(t, t_0) \cong \frac{1}{E_c(t_0)} + \frac{1}{E_{cm}} \sum_{i=1}^n a_j(t_0) (1 - e^{-\alpha_j(t-t_0)}) \quad (4)$$

where n is the number of terms of the Dirichlet series and the coefficients a_j are obtained from a curve fitting using the least squares method. The coefficients $1/\alpha_j$ are called retardation times and are chosen to cover the range of time values for the creep coefficients calculation.

According to Eurocode 2, the total shrinkage strain at an age t , $\varepsilon_{cs}(t)$, is the sum of the autogeneous (ε_{ca}) and the drying shrinkage (ε_{cd}). The drying shrinkage at an age t is defined as

$$\varepsilon_{cd}(t) = \beta_{ds}(t, t_s) \cdot k_h \cdot \varepsilon_{cd,0} \quad (5)$$

where $\beta_{ds}(t, t_s)$ and k_h are coefficients depending on the member notional size and the age of concrete at the beginning of the drying shrinkage. $\varepsilon_{cd,0}$ is a parameter that depends upon the environmental relative humidity, the cement type and the concrete compressive strength.

The autogeneous shrinkage develops due to chemical reactions during hardening in the early age of concrete and it can be expressed at an age t by

$$\varepsilon_{ca}(t) = \beta_{as}(t) \cdot \varepsilon_{ca}(\infty) \quad (6)$$

where $\varepsilon_{ca}(\infty)$ is the long-term value of the autogeneous shrinkage strain and $\beta_{as}(t)$ is a function that gives the evolution of the autogeneous shrinkage with time.

In the structural analysis the time-dependent effects were simulated by equivalent nodal forces that produce the same displacement field as the time-dependent effects and from which is calculated the actual deformation state. These forces are calculated, for each time interval, as initial deformations using the finite element formulation and the corresponding values of the creep and shrinkage strains computed according to the formulation previously presented. The stresses are then computed using only the elastic constitutive relationship between stresses and mechanical origin deformations.

2.5. Geometrical nonlinear effects

There are three main sources of geometrical nonlinearity in cable-stayed bridges: the nonlinear axial force-elongation relationship for the inclined cable stays due to the sag caused by their own weight; the nonlinear axial force and bending moment-deformation relationships for the towers and the deck under combined bending and axial forces; and the geometry change caused by large displacements.

The geometrical nonlinear effects were considered by means of a second-order elastic analysis. The cable stays were modelled as truss elements with stiffness matrix computed using the equivalent modulus of elasticity, i.e., Ernst formula which can describe the catenary action of a cable. The value of the cable equivalent modulus of elasticity is given by

$$E_{eq} = \frac{E}{1 + \frac{(\gamma \cdot L \cos \alpha)^2 E}{12\sigma^3}} \quad (7)$$

where E_{eq} is the equivalent cable modulus of elasticity, E is the effective cable material modulus of elasticity, γ is the specific weight of the cable material, L is the length of the chord, α is the angle between the cable chord and the horizontal direction and σ is the tension stress in the cable.

2.6. Construction methods

Cable-stayed bridges can be built using different erection techniques. The choice of construction method depends on several factors such as the dimension of the structure, condition of the site and cost of possible method. The construction methods that can be used are:

- Construction on temporary supports
- Construction by rotation
- Construction by incremental launching
- Construction by cantilever method

Construction methods which are used in building of cable-stayed bridges of small to medium span are mostly construction on temporary supports, construction by rotation and construction by incremental launching. (Cross, 1997; Grabow, 2004; Mueller-Haagen, 2005; Peter, 2007). Characteristic of all methods, except cantilever method, is that cable stays are installed in one operation. Thus, with these methods it is possible to reduce number of construction stages, number of workers included in construction process. In next paragraphs are described each method.

2.6.1. Construction on temporary supports

In the relatively simple first construction method, the entire bridge girder is erected on temporary supports or on scaffoldings that can be adjusted in order to achieve the correct position. Thereafter, the mounting cable forces are precisely evaluated to balance the vertical deck reactions on the temporary supports, leading to the pretended geometry and stress distribution. The advantage of this erection procedure is that the deck geometry and the cable tension forces can be controlled easily. However, the use of temporary supports fails when clearance of the main span is required during construction and is not economical when the main span of the bridge crosses deep water.

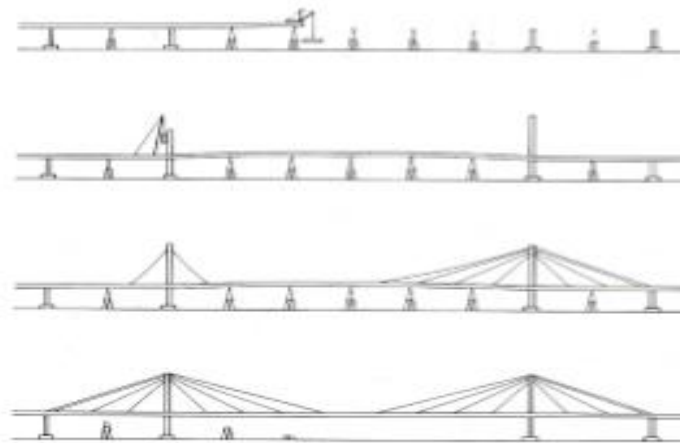

Figure 2.20 – Construction on temporary supports (John Wiley & Sons, 1994)

2.6.2. Construction by rotation

The construction of cable stayed bridges by rotation is the preferred method when building over a waterway, for example a river. The bridge deck is erected on temporary supports at the shore parallel to the bank and after the tensioning of the stay cables it is rotated around its pylon.

2.6.3. Construction by incremental launching

When erecting a cable stayed bridge by the incremental launching method, the superstructure is cast-in-situ at a stationary location behind one of the abutments and is then jacked horizontally into place. The procedure has the advantage that, in contrast to the first two methods, it does not require false work to cast the girder. As in the previous methods, the cable stays can be tensioned in one operation after the construction of the deck. However, and like them, it is generally limited to the construction of small and medium span bridges.

2.6.4. Construction by cantilever method

The cantilevering method is a construction method where segments, either precast or cast-in place, are assembled and stressed together subsequently to form the self-supporting superstructure. Depending on the specific segment configuration and erection sequence chosen for the cantilevering method, the cantilever may never be exactly balanced so that the superstructure needs to be balanced to ensure stability. It is possible to fix the supports at the piers of cantilevering superstructures and install vertical prestressing tendons. Furthermore, it is very common to make use of an additional temporary pier with vertical prestressing that is located close to the permanent one. This pier helps withstanding overturning moments from unbalanced load cases on the bridge superstructure. Additionally, the lateral bending stiffness of the girder must be sufficient, to ensure the stability of the cantilever arm during erection.

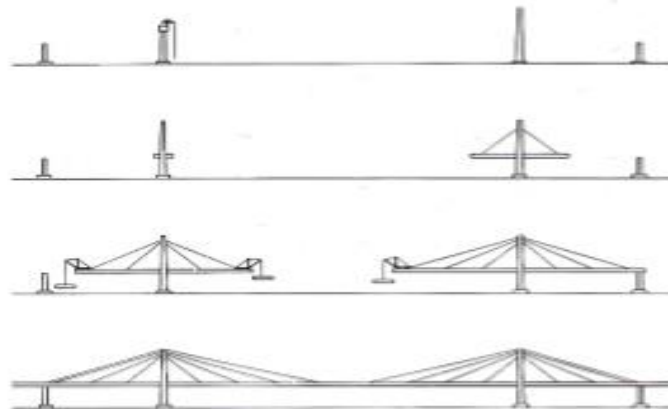

Figure 2.21 – Construction by cantilever method (John Wiley & Sons, 1994)

2.7. Optimization of cable-stayed bridges

Cable-stayed bridge design is an iterative procedure dealing with the definition of overall geometry, the calculation of cable forces` distribution and finding of the members` cross-sections to satisfy displacement and stress criteria from erection to the completion of construction. This is laborious task due to the high redundancy, the large amount of design variables and design objectives that must be dealt with. Optimization techniques are not commonly used in civil engineering practice. However, in the design of large and complex structures like cable-stayed bridges, the use of optimization techniques naturally arises as an efficient way to deal with the large amount of information in view of reduction of material cost and thus obtaining economical and structurally efficient solution.

Application of optimization algorithms in bridge design was made in two large areas. First one is determination of prestressing force which is adjusted to cable stays and second area is determination of geometrical and sectional variables in view of optimal design. In this case, the optimum values of design variables (cross-section dimensions, adjustment cable stay forces, geometric variables) are determined from minimization of certain objective function. These objective functions are formulated due to structural criteria of efficiency and/ or economy to minimize total cost of structure. The objective functions are subjected to constrain of limited displacement and allowable stresses of structural elements and materials.

2.7.1. Optimization of cable force

The determination of the prestressing forces to apply the risers can also be accomplished through the use of optimization algorithms. Several authors have developed work on this theme. Refer below some of these works.

The previous research works concerning the use of optimization algorithms in the design of cable-stayed bridges dealt mainly with the problem of cable tensioning in steel bridges (Chen1992; Negrão and Simões 1997a; Sung et al. 2006; Baldomir et al. 2010). However, the optimization of the cable forces on concrete cable-stayed bridges (Furukawa et al. 1987a; Furukawa et al. 1987b; Kasuga et al. 1995; Janjic et al. 2003) was also reported.

Furukawa et al. 1987a presented a paper referring to cable-stayed bridges of prestressed concrete, and that these tensions have two adjustment systems interacting with each other, respectively pre-efforts on the deck and on the cable stays. In this paper the authors formulate and solve the problem of determining prestressing forces on the cable stays taking into account the effects of prestressing and creep on deck elements. The problem of determining

the forces on the cable stays is solved by minimizing the elastic deformation energy of the deck and pylon.

The same author and others (Furukawa et al, 1987b) gave further state of the problem of optimization of cable-stayed bridges. In this work optimization problem is characterised as multi-objective problem which have to consider, as design variables, not only the forces of prestressing on the cable stays but also the dimensions cross sections elements. Considering complexity of problem, they suggested to solve it in two phases, determining sections through minimization of a cost criterion, and determining the forces on the cable stays through mechanical criteria such as the minimization of the strain energy. However, this approach loses the interaction between the two types of variables in achieving the optimum solution.

Osuo et al (1987) proposed a method for determining the optimization of the adjustment cable stay forces of bridges in the particular case where matrix of influence coefficients of the forces on the cable stay is singular.

Qin (1992) developed a method for determining the optimum planning process of stretching cable stays. Establishing the final configuration desired, based on pre-defined plan and stretching by using the concept of influence pattern, similar to the matrix of influence by other authors used but in view of the construction steps, it is possible to write the final state of structure and overlap effects of the successive stretching steps. The optimization problem is formulated as a linear programming problem can be solved by the Simplex method.

Within the framework of his doctoral thesis (Negrão, 1996) regarding the analysis, sensitivity analysis and optimization of metallic cable-stayed bridges, the author has also undertaken to solve the problem of determining the prestressing forces on the cable stays (Negrao and Simões , 1997). The determination of the forces on the cable stays was formulated as a multi-objective optimization problem where the solution is obtained by minimizing a convex scalar function obtained based on the Maximum Entropy Principle. In the formulation of the problem were considered design variables associated with prestress on the cable stays and cross-sectional geometry and design variables in order to minimize the cost of the structure and observing the permissible stresses in the material and limit the displacement. The construction phases and the effect of catenary cable stays were taken into account in the structural analysis and sensitivity analysis was performed using the direct method with analytic derivatives. In this paper the authors also solved the problem of correcting deviations in shifts during construction by adjusting the forces on the cable stay by a similar formulation

to the previously mentioned but only with use of decision variables associated with prestressing.

Lee et al (2008) presented a paper proposing improvements to the "unit force method" (Janjic et al, 2003) in order to solve specific problems of the determination of the forces on the risers in Wando Bridge, a bridge asymmetric straps built in South Korea . Thus, in addition to the iterative cycle used to determine the forces on the risers considering restrictions on the deck and pylon displacement, proposed to add a new iterative cycle in order to check the upper and lower limits imposed forces on certain cables. With the proposed methodology has improved the distribution of forces on the cable stays and bending moments on the deck, making them more uniform.

More recently, Hassan et al (2012) and Hassan (2013) presented a methodology for determining the strength of prestressing of the tie cable stays and their cross sections considering a cable-stayed bridge in its final configuration and subject to permanent loads. This methodology was based on the observation that the distribution of the prestressing forces on the cable stays along the deck follows an arbitrary polynomial function. Thus, the authors used "B-spline" functions to model the distribution of forces in the struts along the deck. Genetic algorithms were used to obtain the optimal solution regarding the distribution of forces in the struts that minimize the vertical and horizontal displacements of the deck and on top of the pylon. Thus, it was possible also to minimize the distribution of bending moments on the deck and pylon.

2.7.2. Optimization of sectional and geometrical variables

The optimization algorithms also can be used in order to minimize the cost of cable-stayed bridges. Use of them in a process of minimization was studied by several authors. In this process it can be considered optimization of segmental parts of bridge or optimization of geometrical dimensions of main elements of cable-stayed bridges.

Bhatti et al (1985) have formulated and solved the problem of optimal design of a metallic cable-stayed bridge. He considered only sectional variables and objective function set as the weight of the bridge structure, imposing restrictions on the movements and stresses, taking into account the allowable stresses of the materials and the risk of instability due to buckling. The solution was obtained by minimizing the objective function using a quadratic programming algorithm.

Ohkubo and Taniwaki (1991) presented an optimization method to minimize the cost of steel cable-stayed bridges considering specified variables connected with the dimensions of the cross sections of the geometric elements and variables corresponding to the position of the anchors of the cable stays and lifters in the pylons. They were considered restrictions tensions in the elements to ensure the allowable stresses in the materials. Given the results, the authors pointed out the importance of considering both types of specified variables for a more economical solution.

Negrao (1996) in his doctoral thesis studied the analysis, sensitivity analysis and optimization of metallic cable-stayed bridges. In addition to the work already referred to in 2.5.1 on determining the forces of prestressing the tie cable stays were also considered sectional and geometric specified variables and have appealed the two-dimensional modeling (Simões and Negrao, 1994) and three-dimensional structure (and Negrao Simões, 1997). It was named materially linear behaviour of the structure steel but was taken into account effect Catenary risers through modelling of the tie cable stays with connecting cable members with equivalent elastic modulus. The influence of the construction phases was also taken into account in the analysis, through a chronological discretization of the structure made with a physical separation of the corresponding substructures the various stages of the construction process. As mentioned before for the determination of the forces on the cables, the optimization was formulated as a multi-objective problem in which the solution has been obtained by minimizing a convex scalar function obtained based on the Maximum Entropy Principle. They consider themselves as objectives cost structure, tensions in the elements and the displacements of the nodes of the structure. Studies were carried out considering the dynamic action of earthquakes (Simões and Negrao, 1999) and cell box criss-section (Negrao and Simões, 2000).

Battle et al (2009) presented a paper on the minimization of the cost of a cable-stayed bridge. And geometric sectional variables and constraints have been considered in the vertical displacement of the deck and horizontal displacement on top of the pylon and also stresses, taking into account the allowable stress and the buckling instability. The solution was obtained through an optimization problem solved with a joint approach based on genetic algorithms and "support vector machine" (SVM). The use of SVM possible to reduce the time required for convergence of the solution using genetic algorithms. These solutions were further examined to verify its validity.

Baldomir et al (2010) presented a methodology, by applying an optimization algorithm to minimize the amount of prestressing steel cables in a metal cable-stayed bridge. The proposed methodology involves use of both programs ABAQUS and MATLAB and is designed like: first program for structural analysis and the second for optimization. Considering the structure subject to permanent loads, prestressing forces are determined so as to ensure that vertical displacement in the deck is zero and also horizontal displacements at the top of the pylon are zero. The objective function which was minimized is the total volume of steel cables, subject to restrictions in tensions on the risers in vertical movements in their anchor points on the deck and horizontal displacements at the top of the pylon. The solution was obtained by an algorithm that minimizes function of several variables subject to inequality constraints using a sequence of quadratic programs.

Recently, Ferreira and Simões (2011) developed a work on the optimization of the dynamic behaviour of a metallic cable-stayed bridge using a control strategy to locate the seismic action. The dynamic analysis used an analytical solution and took into account the spatial variability of the seismic action, the location of the sensors and the delay the actuators. In the optimization algorithm were considered as design variables, geometric parameters of the structure (height of pylons and position of the anchors of the cable stays on the deck and pylons), dimensions of the cross sections (the cable stays, the deck and the pylons) and the algorithm of control. The integrated optimization strategy of structure and control devices allowed minimizes the cost and improves the dynamic properties of the structure and waste of energy. Following the previous work, the same authors (Ferreira and Simões, 2012) developed an integrated approach to the design of the structure and control devices, with a view to minimizing the cost of pedestrian cable-stayed bridges, equipped with passive and active monitoring devices. The optimization problem was formulated as multi-objective optimization problem which have to minimize the cost, stresses, the accelerations and displacements. The Pareto solution was obtained by minimizing a convex scalar function obtained based on the Maximum Entropy Principle. They were obtained efficient optimal solutions with either passive devices or active, with different geometries, weight distributions and cost. The results showed that the use of an integrated approach enables to take better advantage of the control devices, thereby reducing the weight and cost of the structure and improving control efficiency.

2.7.3. Linear programming

Mathematical programming is concerned with the extremization of an objective function defined over an n-dimensional design space and bounded by a set of constraints in the design space. The set of constraints may be defined by equality or inequality constraints and these constraints may assume linear or nonlinear forms. The function f is called a mathematical program or a mathematical programming problem.

The term linear programming (LP) describes a particular class of extremization problems in which the objective function and the constraint relations are linear functions of the design variables. Because the necessary conditions for an interior minimum is the vanishing of the first derivative of the function with respect to the design variables, linear programming problems have a special feature. That is, the derivatives of the objective function with respect to the variables are constants which are not necessarily zeroes. This implies that the extremum of the linear programming problem cannot be located in the interior of the feasible design space and, therefore, must lie on the boundary of the design space described by the constraint relation.

Linear programs are problems that can be expressed in canonical form:

$$\begin{aligned} & \text{maximize } c^T x \\ & \text{subject to } Ax \leq b \\ & \text{and } x \geq 0 \end{aligned} \quad (8)$$

where x represents the vector of variables (to be determined), c and b are vectors of (known) coefficients, A is a (known) matrix of coefficients, and $(\cdot)^T$ is the matrix transpose. The expression to be maximized or minimized is called the objective function ($c^T x$ in this case). The inequalities $Ax \leq b$ and $x \geq 0$ are the constraints which specify a convex polytope over which the objective function is to be optimized. In this context, two vectors are comparable when they have the same dimensions. If every entry in the first is less-than or equal-to the corresponding entry in the second then we can say the first vector is less-than or equal-to the second vector.

Linear programming can be applied to various fields of study. It is used in business and economics, but can also be utilized for some engineering problems. Industries that use linear programming models include transportation, energy, telecommunications, and manufacturing. It has proved useful in modelling diverse types of problems in planning, routing, scheduling, assignment, and design.

Necessity of solving a system of linear inequalities first shown in 1827, when Fourier published a method for solving that kind of problem, later called method of Fourier-Motzkin elimination. First linear programming formulation was given by Leonid Kantorovich in 1939. His method was used as a plan expenditures and returns so as to reduce costs to the army and to increase losses incurred by the enemy. Around same year Koopmans formulated classical economic problems as linear programs. In 1941, Hitchcock also formulated transportation problem as linear programs and gave solution very similar to the later Simplex method. Simplex method was invented by George Dantzig in 1947, and for the first time efficiently tackled the linear programming problems in lot of cases. The linear programming problem was first solve in polynomial time in 1979 by Khachiyan, but large breakthrough in this part came in 1984 by Karmarkar who introduced interior-point method for solving linear programming problems.

An optimal solution of linear programming does not need to exist and it can happen it two cases. First, if two constraints are inconsistent, than feasible solution does not exist. Second, if the polytope is unbounded in the direct of the gradient of objective function, than again optimal solution does not exist. Geometrically, the linear constraints define the feasible region, which is convex polyhedron. A linear function will has optimal solution if the function is convex or concave function. That implies if function is convex every local minimum is also global minimum and if function is concave every local maximum is global maximum. Otherwise, if a feasible solution exists and if objective function is bounded, than optimal solution is always attained on the boundary of optimal set.

Today, for solving linear programming problems, we have several different algorithms which are divided in two groups:

- Basis exchange algorithms
- Interior point

In a group of basis exchange algorithms most important algorithms are:

1. Simplex algorithm of Dantzig

Algorithm was developed in 1947, and solving problems by constructing a feasible solution as vertex of the polytope and then walking along of the edges of polytope to vertices with non-decreasing values of objective function until an optimum solution is reached.

2. Criss-cross algorithm

It is an algorithm that pivots between bases. This algorithm does not need to maintain feasibility, but can pivot rather from a feasible basis to an infeasible basis. Disadvantage of this algorithm is that it does not have polynomial time-complexity for linear programming.

Second group is group of Interior points and most important algorithms are:

1. Ellipsoid algorithm

This algorithm was first worst-case polynomial-time algorithm for solving linear programming problems. The convergence analysis has real-number predecessors, notably the iterative methods developed by Shor and the approximation algorithms by Nemirovski and Yudin.

2. Projective algorithm

Importance of this algorithm was that he established polynomial-time solvability of linear programming. This algorithm improved ellipsoid algorithm and it was much faster in practical LP problems than simplex method.

3. Path-following algorithms

In contrast to simplex method interior point methods find optimal solution moving through the interior of the feasible region. For theoretical and practical purpose these algorithms were used.

Chapter 3. Optimum design formulation

3.1. Introduction

To describe optimization concepts and methods, we need a general mathematical statement for the optimum design problem. Such a mathematical model is defined as minimization of a cost function while satisfying all the equality and inequality constraints. The inequality constraints in the model are always transformed as “ \leq types”.

In this thesis, the optimum design of concrete cable stayed bridge is posed as a multi-objective optimization problem. This involves the definition of the design variables, the design objectives and objective function. In Figure 3.1 it is shown procedure of optimization process.

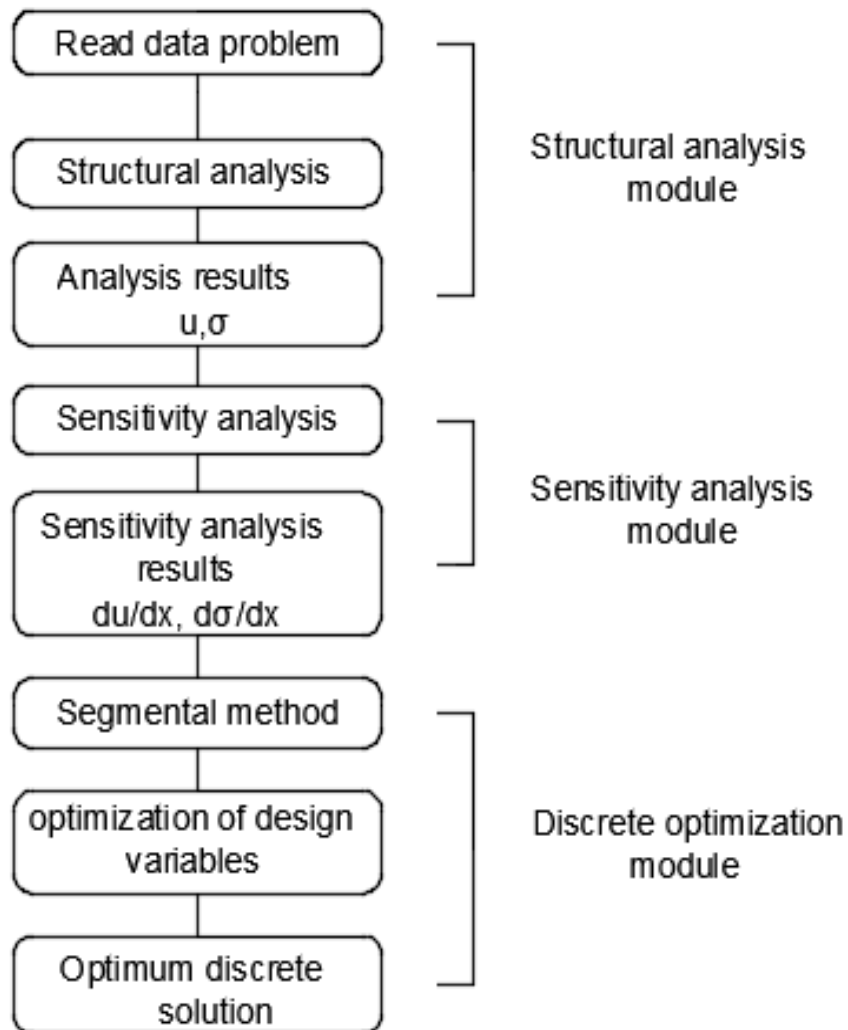

Figure 3.1 – Scheme of optimization process

3.2. Design variables

The notion of optimizing a structure implicitly presupposes some freedom to change the structure. The potential for change is typically expressed in terms of ranges of permissible changes of a group of parameters. These parameters are usually called design variables. Continuous design variables have a range of variation, and can take any value in that range. Discrete design variables can take only isolated values, typically from a list of permissible values. In most structural design problems we tend to disregard the discrete nature of the design variables in the solution of the optimization problem. Once the optimum design is obtained, we then adjust the values of the design variables to the nearest available discrete value.

The design variables, which were considered in this paper, were the cable stay area and prestressing forces, also the cross sectional dimension of the deck and towers. The design variables are represented by x_i , and the global design variable vector is

$$X = \{x_1, x_2, x_3, \dots, x_N\}^T \quad (9)$$

The stay cables were made of 0.6" S stands (15.7 mm normal diameter and 1.5 cm² of cross sectional area). Rectangular hollow sections were considered for the towers cross sections and for the deck was considered single cell box.

Deck and towers cross sectional design variables have direct impact in weight (or cost) reduction. Cable areas and cable forces play an essential role in stress distribution throughout the structure, because they define the extent of the beam like behaviour of the deck. Moreover, they are fundamental for adjusting bridge geometry and deflection control, which otherwise could only be achieved by a sever stiffening of the deck, in opposition to the expected reduction of material.

3.3. Design objectives

The notion of optimization also implies that there are some merit function $f(x)$ or functions $f(x) = \{f_1(x), f_2(x), \dots, f_n(x)\}$ that can be improved and can be used as a measure of effectiveness of the design. The common terminology for such functions is objective functions. Optimization with more than one objective is generally referred to as Multi-criteria Optimization. For structural optimization problems, weight, displacements, stresses, vibrations frequencies, buckling loads, and cost or any combination of these can be used as objective function. Optimization problem in this paper is considered as multi-objective optimization problem.

The design of cable stayed bridges involves achieving some design objectives in order to check the service and strength criteria. The objectives should be cast in a normalized form. They arise from imposing limits in displacement and stresses for the complete bridge under permanent and live load. Also, the design should seek to minimize the cost of structure. Considering this, goal can be expressed as

$$g_1(x) = \frac{C}{C_0} - 1 \leq 0 \quad (10)$$

where C is the current cost of the structure and C_0 is a reference cost, which corresponds to the initial cost of each analysis and optimization cycle. This ensured that in each cycle the cost is always one of the objectives for the optimization algorithm. The cost of the structure was formulated as the cost of the materials (concrete and prestressing steel). The materials unit prices were obtained consulting supplier companies.

The second set of objectives comes up from limiting the deck vertical and towers horizontal displacement to achieve the desired final deck profile and to minimize the tower bending deflections

$$g_2(x) = \frac{|\delta|}{\delta_0} - 1 \leq 0 \quad (11)$$

where δ and δ_0 are the displacement value and the limit value for the displacement under control.

A third set of goals arises from imposing limits for the stresses of deck and towers for the complete bridge under permanent load. These goals are related to the service conditions.

According to Eurocode 2 (EN 1992-1-1 2010) recommendations the concrete compressive stress were limited to 45 % of the characteristic value of the concrete compressive strength (f_{ck}), so the concrete remains within the range of linear creep and also longitudinal cracking is prevented. The concrete tensile stresses were limited to the 5 % fractile of the characteristic axial tensile strength of concrete ($f_{ctk, 0, 05}$) to avoid cracking and, thus ensuring durability:

$$g_3(x) = \frac{\sigma_c}{f_{ctk, 0, 05}} - 1 \leq 0 \quad (12)$$

$$g_4(x) = \frac{\sigma_c}{0,45 f_{ck}} - 1 \leq 0 \quad (13)$$

where σ_c is acting stress in the concrete members. The tensile and compressive stresses and correspondent allowable stresses are used considering the respective signals.

The concrete members should also be checked for the maximum stresses. This goal can be expressed as

$$g_5(x) = \frac{\sigma_c}{\sigma_{allow}} - 1 \leq 0 \quad (14)$$

where σ_c is the acting stress in the concrete members and σ_{allow} is the correspondent allowable stress in tension or compression. The acting stresses are calculated from the acting axial force (N_{Ed}) and bending moment (M_{Ed}). The allowable value is computed as a stress equivalent to the combined axial force-bending moment design resistance (N_{Rd} , M_{Rd}) of the cross section. This value is obtained from the non-dimensional interaction diagram generated for the respective cross section of the concrete member. For these calculations the reinforcing steel area was not a design variable and was considered 2% of the concrete cross sectional area. This was adopted as mean value of reinforcing steel area for the concrete members and represents a common practical value.

The remaining objectives concerning the stresses in the stays are

$$g_6(x) = \frac{\sigma}{0,45f_{pk}} - 1 \leq 0 \quad (15)$$

$$g_7(x) = 1 - \frac{\sigma}{0,1f_{pk}} \leq 0 \quad (16)$$

where σ and f_{pk} are the acting stress in the stays and the characteristic value of the prestressing steel strength, respectively. If the acting stress is greater than $0,1f_{pk}$, the Equation 15 applies, if the acting stress is less than or equal to $0,1f_{pk}$, the Equation 16 applies. To avoid detrimental effects of fatigue and according to common design recommendations, an upper limit of $0,45f_{pk}$ was considered for the stresses in the stays (EN 1993-1-11 2006). A lower limit of $0,1f_{pk}$ for the tensile stress in the stays was considered to ensure their structural efficiency.

3.4. Objective function

In this thesis, the design of the concrete cable-stayed bridges is formulated as a multi-objective optimization problem from which a Pareto optimal solution vector is obtained. This means that no other feasible vector exists that could decrease one objective without increasing at least another one. The optimum vector is usually exists but sometimes it is not unique. The objective of the multi-objective optimization problem is to minimize the set of all objectives over the design variables. This is achieved by the minimax optimization problem

$$\text{Min}_x \text{Max}_y (g_1, g_2, \dots, g_j) \quad (17)$$

This problem is discontinuous and non-differentiable and thus difficult to solve. However, as started in (Simões and Templeman, 1989), it may be shown that using the Shannon/Jaynes maximum entropy principle and Cauchy's arithmetic-geometric mean inequality, the solution of the minimax optimization problem with objectives defined by Equation 10 to 16 can be found indirectly by minimizing the unconstrained convex scalar function, that turns out to be the well-known Kreisslmeier-Steinhauser function

$$\min F(x) = \min \frac{1}{\rho} \ln \left[\sum_{j=1}^M e^{\rho(g_j(x))} \right] \quad (18)$$

which is both continuous and differentiable and thus considerably easy to solve. This function depends only on one control parameter, ρ , which must not be decreased to ensure that multi-objective solution is found. In this thesis a constant value for ρ of 10 was used. The optimization of the convex scalar function (Equation 18) may be solved by conventional quasi-Newton methods, with which an optimal solution (in the Pareto sense) is achieved for each trial design.

The goal functions $g_j(x)$ do not have an explicit algebraic form and are only obtained numerically from the structural analysis results of a particular design variable vector. The strategy adopted was to solve Equation 18 by means of an iterative sequence of explicit approximation models. An explicit approximation can be formulated by taking Taylor series expansions of all the goal functions $g_j(x)$ truncated after the linear term. This gives:

$$\min F(x) = \min \frac{1}{\rho} \ln \left[\sum_{j=1}^M e^{\rho \left(g_{0j}(x) + \sum_{i=1}^N \frac{dg_{0j}(x)}{dx_i} \Delta x_i \right)} \right] \quad (19)$$

where N and M are, respectively, the number of design variables and the number of objectives. $g_{0j}(x)$ and $dg_{0j}(x)/dx_i$ are the objectives and their sensitivities evaluated for the current design variable vector (x_0), at which the Taylor series expansion is made. Solving Equation 18 for particular numerical values of $g_{0j}(x)$ forms only one iteration of the problem's complete solution. The solution vector (x_1) of such iteration represents a new design that must be analysed and given new values for $g_{1j}(x)$, $dg_{1j}(x)/dx_i$ and (x_1), to replace those corresponding to (x_0) in Equation 18. Iterations continue until changes in the objective function become small. Upper and lower bound constraints of 2% of the current values of the design variables were imposed as move limits to ensure the accuracy of the explicit approximation. The minimization of the objective function was carried out using the MATLAB function *linprog*, which minimize an objective function using linear large-scale optimization.

3.5. Sensitivity analysis

The first step in the analysis of the complex structure is spatial discretization of the continuum equations into a finite element, finite difference or similar model. The analysis problem then requires the solution of algebraic equations (static response), algebraic eigenvalue problems (buckling or vibrations) or ordinary differential equations (transient response). The sensitivity calculation is then equivalent to the mathematical problem of obtaining the derivatives of the solutions of those equations with respect to their coefficients. The simplest technique for calculating derivatives of response with respect to design variables is the finite-difference approximation. This technique is often computationally expensive, but is easy to implement and very popular.

The simplest finite difference approximation, also used in this thesis, is the first-order forward-difference approximation. Given a function $u(x)$ of a design variables x , the forward-difference approximation

$$\frac{\Delta u}{\Delta x} = \frac{u(x + \Delta x) - u(x)}{\Delta x} \quad (20)$$

If we need to find the derivatives of the structural response with respect to n design variables the forward-difference approximation requires n additional analyses and higher order approximations are even more expensive.

The sensitivity analysis module is very important for the performance of the iterative optimization algorithm and the evolution of the problem solution depends on the accuracy with which the sensitivities are computed. This module allows knowing the way a variation in each design variable will affect the design objectives and the objective function of the optimization problem. Given the availability of the source code, the discrete nature of cable stayed bridge structures and the large number of objectives (stresses and displacement) under control, the analytical discrete direct method was used for the sake of sensitivity analysis. The sensitivities of displacements are obtained by differentiating the equilibrium equations

$$K \cdot u = F \quad (21)$$

from which the following expression is obtained:

$$\frac{dK}{dx_i}u + K \frac{du}{dx_i} = \frac{dF}{dx_i} \quad (22)$$

which can be rewritten in the form

$$K \frac{du}{dx_i} = \frac{dF}{dx_i} - \frac{dK}{dx_i}u = Q_{vi} \quad (23)$$

where Q_{vi} is the virtual pseudo-load vector of the system with respect to the i th design variable. The displacement sensitivities can be expressed as:

$$\frac{du}{dx_i} = K^{-1} \cdot Q_{vi} \quad (24)$$

which requires storing the stiffness matrix, pre-programming stiffness matrix and right-hand side derivatives so the displacement derivatives may be computed by the solution of N pseudo-load right hand sides.

The stress sensitivities are determined from the chain derivation of the finite element stress-displacement relation

$$\sigma = D \cdot B^e \cdot u^e \quad (25)$$

$$\frac{d\sigma}{dx_i} = \frac{d(D \cdot B^e)}{dx_i} \cdot u^e + D \cdot B^e \cdot \frac{du^e}{dx_i} \quad (26)$$

The first term of the right-hand side may be directly computed during the computation of element contribution for the global system, on the condition that derivative expressions are pre-programmed and called on that stage. Since the displacement derivatives are known, the second term on the right-hand side is easily computed.

3.6. Segmental optimum design

The segmental method assumes that each member of the structure is composed of a total of D segments, each with geometrical properties equal to one of discrete sizes t_d , $d = 1, \dots, D$, such that all sizes are represented among the segments. Let l_{id} be the unknown length of the segment of member I which belongs to the discrete set t_d , $d = 1, \dots, D$. This is shown in Figure 3.3 for a member which has three discrete sizes. The geometry of all segments is known, but the lengths are unknown. The ordering of the segments along a member is immaterial.

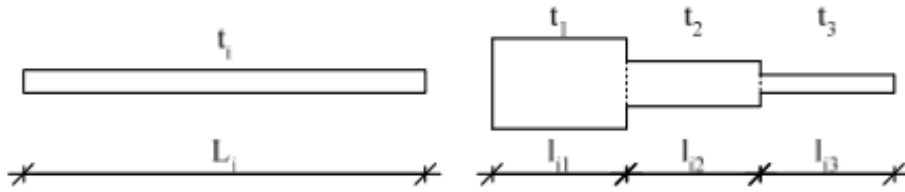

Figure 3.2 - Conventional member and segmental member

t_d represents discrete thickness for the plates of the deck and pylons cross sections. Considering that, the structure volume minimization problem using the segmental method can be formulated as:

$$\min Z = C \cdot X \quad (27)$$

$$\min Z = l_{11} \cdot t_1 + l_{12} \cdot t_2 + l_{13} \cdot t_3 + \dots + l_{id} \cdot t_d = \sum_{i=1}^N \sum_{d=1}^D l_{id} \cdot t_d \quad (28)$$

Subject to

$$\sum_{d=1}^D l_{id} = L_i; i = 1, \dots, N \quad (29)$$

Equation 29 means that the sum of the segment lengths of each bar must total the bar length;

$$\sum_{d=1}^D \sigma_{id} \cdot l_{id} \leq \sigma_{ad} L_i \quad (30)$$

Moreover the stress in each element must be less than admissible value. Also displacement constraints could be formulated

$$\sum_{d=1}^D \delta_{id} \cdot l_{id} \leq \delta_0 L_i \quad (31)$$

The cost vector C , contains the values of the D discrete sections available and vector X contains the design variables that are the lengths l_{id} of all the segments of all members. To enable a computer solution of the design optimization problem it is first necessary to formulate the stress σ in each member as an explicit function of the design variables. Since stress varies inversely with the section properties a good quality explicit approximation of each stress σ , is provided by the first order Taylor series:

$$\sigma = \sigma_0 + \sum_{i=1}^n \frac{d\sigma}{dx_i} \cdot x_i \quad (32)$$

where the subscription zero (0) defines known quantities for the current structure, while x , are the design variables and Δx_i denotes the variation in that design variables. Problem z is an LP problem which may be solved by any LP algorithm, and will yield what can be termed segmental optimum design.

Chapter 4. Numerical example and results

4.1. Description of numerical model

To illustrate the features of proposal numerical method, it was applied to analyse a cable-stayed bridge structure. This example is composed by a symmetrical concrete cable-stayed bridge with total length of 284 m, with central span of 148 m and lateral spans of 68 m. pylons total height is 52 m with deck placed 15 m above the foundations. Figure 4.1 presents the geometry of bride example and on Figure 4.2 is presented zones for cross-sections of the bridge.

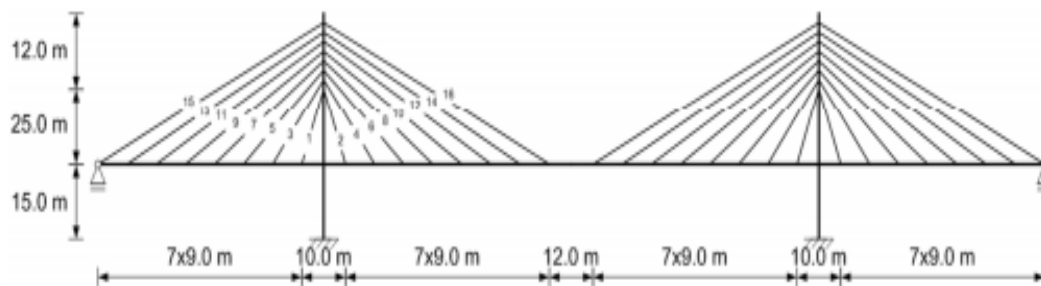

Figure 4.1 - Geometry of cable-stay bride

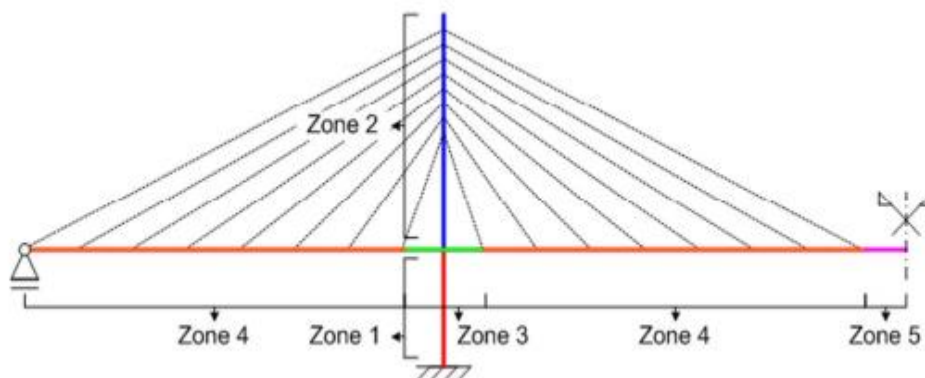

Figure 4.2 – Zones for the cross-section design variables

Half of the bridge was modelled, by using structural and load symmetry. It was considered actions of self-weight of deck and the construction load of 1 kN/m^2 due to personal and hand tool. The allowable stresses were set at 35 MPa for the deck and pylon and 500 MPa for cable stay elements. Minimum stress in stays is prescribed as 10% of allowable stress. Table 4.1 present the properties of materials used in the numerical model.

Concrete C35/45 (deck and towers)	Prestressing steel – Cable-stays
$E = 34 \text{ GPa}$; $\gamma = 25 \text{ kN/m}^3$	$E = 195 \text{ GPa}$; $\gamma = 77 \text{ kN/m}^3$
$f_{ck} = 35 \text{ MPa}$; $f_{ct,0.05k} = 2.2 \text{ MPa}$	$f_{pk} = 1860 \text{ MPa}$; $f_{p0.1k} = 1770 \text{ MPa}$
$f_{cd} = 23.3 \text{ MPa}$	Cost: 1200 €/ton
Mean Relative Humidity = 80%	Reinforcing steel – A500 NR
Type N cement	$E = 200 \text{ GPa}$; $f_{yk} = 500 \text{ MPa}$; $f_{yd} = 435 \text{ MPa}$
Cost: 135 €/m ³	$\epsilon_{yk} = 2.5 \times 10^{-3}$; $\epsilon_{yd} = 2.174 \times 10^{-3}$
	Cost: 900 €/ton

Table 4.1 - properties of materials

4.2. Design variables

For the numerical example analysed the overall geometry of the bridge and the deck widths (19.00 and 9.00 m) were pre-assigned constants parameters. For the definition of the sizing design variables two zones in pylon and three zones in deck were considered as shown in Figure 4.3 for the cross-sectional geometry of the deck was considered single-cell box cross section and for the pylons rectangular hollow sections.

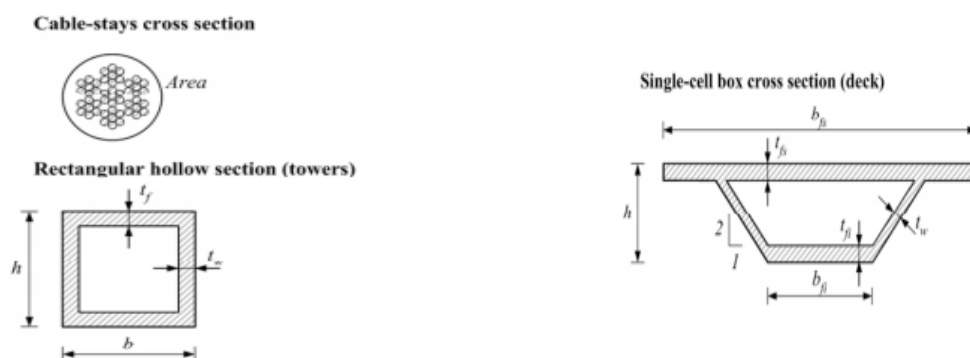

Figure 4.3 - Cross-sectional geometry of the bridge elements

A continuous design was made in paper (Martins, Simões, Negrão, 2014) to obtain a starting point for the discrete design. Table 4.3 shows the initial values of the design variables obtained with the continuous optimization procedure. A total of 18 design variables were considered and they are described in Tables 4.2

Number	Design variable
1	h deck cross-section Zone 3
2	tfs=tfi deck cross-section Zone 3
3	tw deck cross-section Zone 3
4	h deck cross-section Zone 4
5	tfs=tfi deck cross-section Zone 4
6	tw deck cross-section Zone 4
7	h deck cross-section Zone 5
8	tfs=tfi deck cross-section Zone 5
9	tw deck cross-section Zone 5
10	h pylon cross-section Zone 1
11	h pylon cross-section Zone 2
12	b pylon cross-section Zone 1
13	b pylon cross-section Zone 2
14	tw pylon cross-section Zone 1
15	tw pylon cross-section Zone 2
16	tfi pylon cross-section Zone 1
17	tfi pylon cross-section Zone 2
18-33	cable instalation forces for stays 1 to 16
33-49	cable adjstment forces for stays 1 to 16

Table 4.2 - Design variables (single-cell box examples)

Number	Initial value	Design variable
1	1,878	h deck cross-section Zone 3
2	0,163	tfs=tfi deck cross-section Zone 3
3	0,163	tw deck cross-section Zone 3
4	2,731	h deck cross-section Zone 4
5	0,152	tfs deck cross-section Zone 4
5	0,176	tfi deck cross-section Zone 4
6	0,150	tw deck cross-section Zone 4
7	1,576	h deck cross-section Zone 5
8	0,150	tfs=tfi deck cross-section Zone 5
9	0,150	tw deck cross-section Zone 5
10	4,959	h pylon cross-section Zone 1
11	4,691	h pylon cross-section Zone 2
12	4,759	b pylon cross-section Zone 1
13	4,691	b pylon cross-section Zone 2
14	0,391	tw pylon cross-section Zone 1
15	0,391	tw pylon cross-section Zone 2
16	0,391	tfi pylon cross-section Zone 1
17	0,391	tfi pylon cross-section Zone 2

Table 4.3 – Initial values of design variables (single-cell box examples)

4.3. Optimum design results

The solution of the segmental method was obtained by linear programming. In this work large-scale algorithm was used.

In order to obtain a discrete optimum design two different approaches were made. In the first one the optimization of the pylon cross-sections was made independently from the discrete solution of the deck cross-section. In the second one the discrete solution for the pylon cross-section was obtained taking into account the discrete solution achieved for the deck cross-section.

The initial values and the results obtained after optimization and the discrete optimum obtained by rounding the continuous optimum design are presented in Tables 4.4 and 4.5, for the cable forces and the sizing design variables, respectively.

Design variable	Cable installation forces [kN]		
	Initial	Final	Adjustment for Discrete Solution
18	1000	1000	990
19	1000	985	983
20	1500	1484	1454
21	1500	1464	1457
22	1500	1506	1505
23	1500	1457	1457
24	1500	1525	1527
25	1500	1542	1542
26	2000	2062	2066
27	2000	2232	2231
28	2000	2118	2125
29	2000	2350	2348
30	2000	2360	2370
31	2000	2486	2482
32	2000	2249	2263
33	2000	2671	2665

Table 4.4 – Cable installation forces (initial, final continuous and discrete values)

The results presented in Table 4.4 show that the cable forces increase from the tower to the mid-span. The forces are similar for symmetrically disposed stays. As desired for an adequate structural behaviour the highest forces occur in the backstays. These forces counterbalance the largest load in the central span when compared with the side span and control the tower bending deflections and stresses.

Figure 4.4 shows the evolution of the objective function and of the bridge cost during the analysis-and-optimization process.

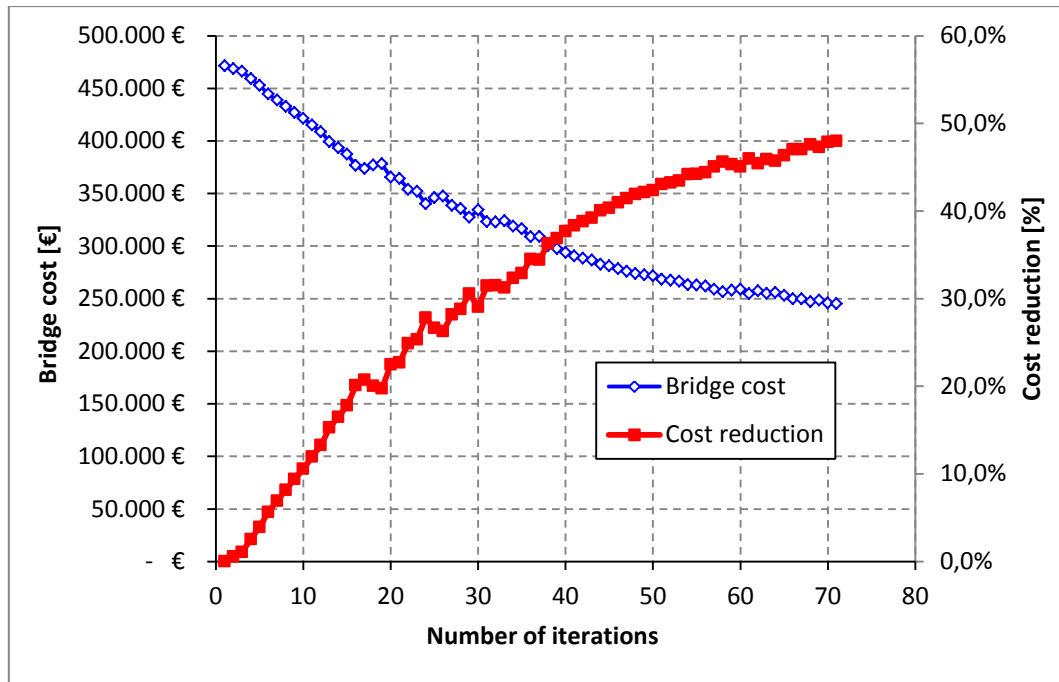

Figure 4.4 – Evolution of the bridge cost vs number of iterations

Sizing Design Variables	Continuous Initial	Discrete Final
1	1,878	1,550
2	0,163	0,550
3	0,163	0,150
4	2,731	2,250
5	0,152	0,150
6	0,176	0,500
7	1,576	1,550
8	0,15	0,750
9	0,15	0,200
10	4,959	2,950
11	4,691	2,350
12	4,759	2,500
13	4,691	2,300
14	0,391	0,200
15	0,391	0,200
16	0,391	0,200
17	0,391	0,200

Table 4.5 – Sizing design variables (initial continuous and discrete values)

Design variable	Cable adjustment forces [kN]		
	Initial	Final	Adjustment for Discrete Solution
34	1500	1523	1522
35	1500	1483	1483
36	2000	2019	2018
37	2000	1969	1970
38	2000	1977	1977
39	2000	1949	1950
40	2000	1919	1921
41	2000	1955	1956
42	3000	2910	2915
43	3000	2988	2988
44	3000	3003	3011
45	3000	3048	3048
46	3000	3116	3128
47	3000	3135	3133
48	3500	3699	3716
49	3000	3250	3247

Table 4.6 – Cable adjustment forces (initial, final continuous and for discrete sizing variables)

In this example, the deck represents the largest contribution to the bridge cost with a value of 76.7% of the total cost. The cable stays represent 13.2% and the towers represent 10.1% of the bridge total cost.

	Deck	Stays	Towers	Cost	% Cost increase
Continuous	190.389,40 €	31.227,98 €	22.999,46 €	244.616 €	
	77.8%	12.8%	9.4%	100.0%	
Discrete before force adjustment				248,67 €	1.66%
Discrete after force adjustment	190.590,86 €	32.764,34 €	25.275,02 €	248.630 €	1.64%
	76.7%	13.2%	10.1%	100.0%	

Table 4.7 – Deck, tower and stays costs

Figures 4.5 and 4.6 represent vertical displacements and normal stresses, respectively for the continuous optimum and the discrete solution after cable adjustment. The feasible discrete optimization (after the cable adjustment forces are found) leads to a cost increase of 1.60%. The segmental optimization is unnecessary here.

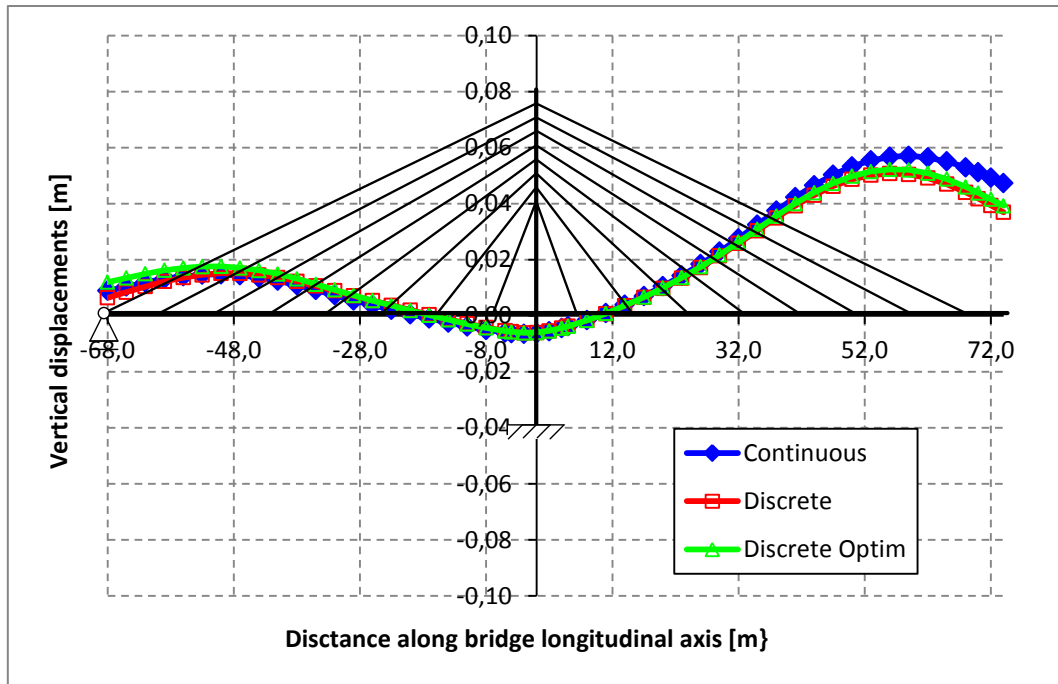

Figure 4.5 – Deck vertical displacements (continuous and discrete solutions after cable adjustment)

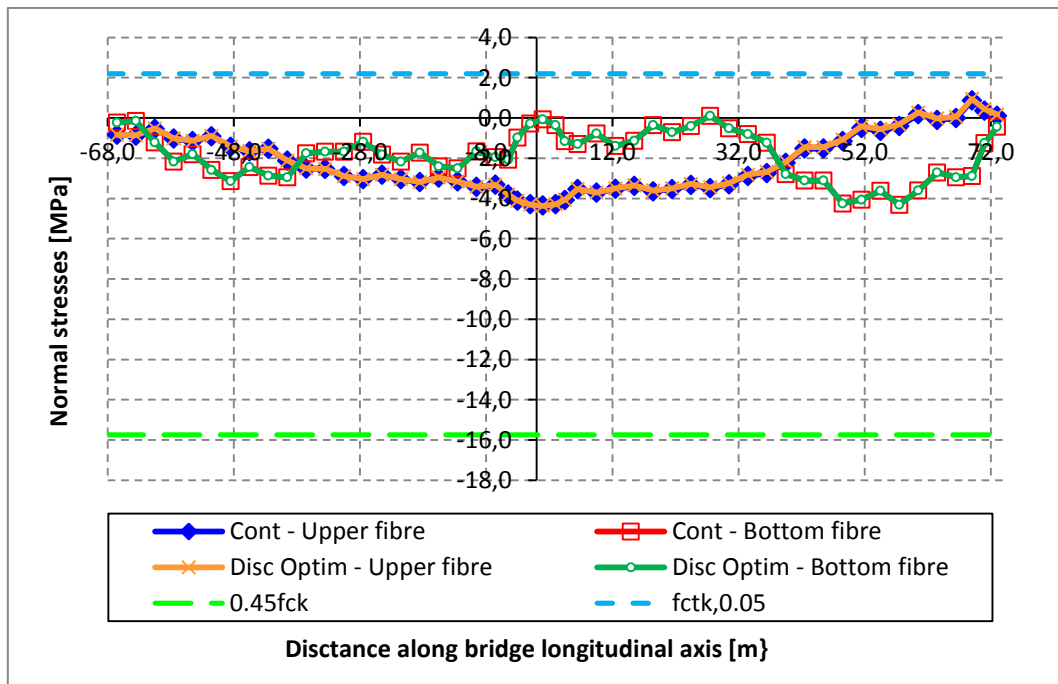

Figure 4.6 – Deck normal stresses (continuous and discrete solution after cable adjustment)

Chapter 5. Conclusions

In this thesis, the optimum design of concrete cable-stayed bridge is formulated as multi-objective optimization problem with objectives of minimum cost, minimum displacement and stresses. According to the results the following conclusions can be drawn:

- The results show that is possible to formulated and solve the design problem of concrete cable-stayed bridge as multi-objective optimization problem considering the cable pre-stressing force and cross-sectional dimensions of deck and pylon as design variables
- The consideration of cable forces, cable areas, deck and tower sizing design variables allows the cost minimization and obtaining structural efficient solutions with adequate values of displacements and stresses throughout the structure.
- The procedure used in this work seems to be adequate to the discrete optimization of a cable-stayed bridge revealing to be more efficient than combinatorial or genetic algorithms.
- The segmental method employed here extends the original concept of displacement based design to accommodate stresses by employing an explicit approximation of these constraints.

References

- Baldomir, A., S. Hernandez, F. Nieto, and J. A. Jurado. 2010. "Cable optimization of a long span cable stayed bridge in La Coruña." *Advances in Engineering Software* 41: 931–938.
- Bazant Z. P. 1988. "Material models for structural creep analysis." In *Mathematical modelling of creep and shrinkage of concrete*, edited by Z. P. Bazant, 99-215. John Wiley and Sons, Ltd.
- Chen Qin. 1992. "Optimization of cable-stretching planning in the construction of cable-stayed bridges." *Engineering Optimization* 19: 1-20.
- Chen, Wai-Fah and Lian Duan. 2000. *Bridge Engineering Handbook*. CRC Press. Cluley N.
- C. and R. Shepherd. 1996. "Analysis of concrete cable-stayed bridges for creep, shrinkage and relaxation effects." *Computers & Structures* 58 (2): 337-350.
- Cruz P. J. S., A. R. Mari, and P. Roca P. 1998. "Non-linear time-dependent analysis of segmentally constructed structures." *Journal of Structural Engineering ASCE* 124 (3): 278-287.
- EN 1992-1-1. 2010. NP EN 1992-1-1 Eurocode 2 – Design of concrete structures, Part 1-1: General rules and rules for buildings IPQ – Instituto Português da Qualidade.
- EN 1993-1-11. 2006. EN 1993-1-11 Eurocode 3 – Design of steel structures, Part 1-11: Design of structures with tension components. CEN – Comité Européen de Normalisation.
- Ernst J. H. 1965. "Der E-Modul von Seilen unter berucksichtigung des Durchhanges." *Der Bauingenieur* 40 (2): 52-55 (in German).
- Fleming J. F. 1979. "Nonlinear static analysis of cable-stayed bridge structures", *Computers & Structures* 10 (4): 621-635.
- Freire A. M. S., J. H. O. Negrão and A. V. Lopes. 2006. "Geometrical nonlinearities on the static analysis of highly flexible steel cable-stayed bridges." *Computers & Structures* 84: 2128-2140.
- Furukawa, K., H. Sugimoto, T. Egusa, K. Inoue, and Y. Yamada. 1987b. "Studies on the optimization of cable prestressing for cable-stayed bridges." Paper presented at the International Conference on Cable-Stayed Bridges, Bangkok, Thailand.

- Furukawa, K., I. Sakai, S. Kumagai, H. Arai, and A. Kasuga. 1987a. "Optimization of cable forces in cable-stayed prestressed concrete bridges based on minimum strain energy criterion." Paper presented at the International Conference on Cable-Stayed Bridges, Bangkok, Thailand.
- Hassan M. M. 2013. "Optimization of stay cables in cable-stayed bridges using finite element, genetic algorithm, and B-spline combined technique." *Engineering Structures* 49: 643–654.
- Hassan M. M., A. O. Nassef and A. A. El Damatty. 2013a. "Surrogate function of posttensioning cable forces for cable-stayed bridges." *Journal of Advances in Structural Engineering* 16 (3): 559-578.
- Hassan M. M., A. O. Nassef, and A. A. El Damatty. 2012. "Determination of optimum post-tensioning cable forces of cable-stayed bridges." *Engineering Structures* 44: 248–259.
- Hassan, M. M., A. A. El Damatty, A. O. Nassef. 2014. "Database for the optimum design of semi-fan composite cable-stayed bridges based on genetic algorithms." *Structure and Infrastructure Engineering*, doi: 10.1080/15732479.2014.931976.
- Hewson, Nigel R. 2003. *Prestressed concrete bridges: design and construction*. Thomas Telford Publishing.
- Karoumi, Raid. 1999. "Some modelling aspects in the nonlinear finite element analysis of cable supported bridges," *Computers & Structures* 71: 397-412.
- Kasuga A, H. Arai, J. E. Breen, and K. Furukawa. 1995. "Optimum cable-force adjustments in concrete cable-stayed bridges." *Journal Structural Engineering ASCE* 121(4): 685-694.
- Khalil M. S., W. H. Dilger, and A. Ghali. 1983. "Time-dependent analysis of PC cable-stayed bridges." *Journal of Structural Engineering ASCE* 109 (8): 1980-1996.
- Long, W., M. S. Troitsky, and Z. A. Zielinski. 1999. "Optimum design of cable stayed bridges." *Journal of Structural Engineering and Mechanics* 7 (3): 241-257.
- Lute, V., A. Upadhyay, and K. K. Singh. 2009. "Computationally efficient analysis of cable-stayed bridge for GA-based optimization." *Engineering Applications of Artificial Intelligence* 22: 750-758.

- Martins, A. M. B., L. M. C. Simões, and J. H. J. O. Negrão. 2014. "Cable stretching force optimization of concrete cable-stayed bridges including construction stages and time-dependent effects", *Structural and Multidisciplinary Optimization*. (accepted for publication) doi: 10.1007/s00158-014-1153-4.
- Martins, A. M. B., L. M. C. Simões, and J. H. J. O. Negrão. 2014. "Optimum design of concrete cable-stayed bridges", *Engineering Optimization*. (accepted for publication) doi: GENO-2014-0660.R1
- Mathivat J. 1984. *The cantilever construction of prestressed concrete bridges*. John Wiley and Sons, Ltd. Nazmy A. S., and A. M. Abdel-Ghaffar. 1990. "Three-dimensional nonlinear static analysis of cable-stayed bridges." *Computers & Structures* 34 (2): 257-271.
- Negrão, J. H. J. O., and L. M. C. Simões. 1997a. "Cable stretching force optimization in cable-stayed bridges." Paper presented at the WCSMO-2 The Second World Congress of Structural and Multidisciplinary Optimization, IFTR: 983-987.
- Negrão, J. H. O., and L. M. C. Simões. 1997b. "Optimization of cable-stayed bridges with three-dimensional modelling." *Computers & Structures* 64 (1-4): 741-758.
- Ohkubo S., and K. Taniwaki. 1991. "Shape and sizing optimization of steel cable-stayed bridges." In *Proceedings of OPTI 91 – Optimization of Structural Systems and Industrial Applications*, edited by S. Hernandez and C. A. Brebbia, Elsevier Applied Sciences, Cambridge, MA, USA.
- Simões L. M. C., and A. B. Templeman. 1989. "Entropy-based synthesis of pretensioned cable net structures." *Engineering Optimization* 15: 121-140.
- Simões, L. M. C. 1987. "Search for the global optimum of least volume structures." *Engineering Optimization* 11, 49-67. Simões, L. M. C. 1989. "Isolated global optimality in truss sizing problems." *Computers & Structures* 33 (2), 375-384.
- Simões, L. M. C., and J. H. J. O. Negrão. 2000. "Optimization of cable-stayed bridges with box-girder decks." *Advances in Engineering Software* 31: 417-423.
- Simões, L. M. C., and J.H.O. Negrão. 1994. "Sizing and geometry optimization of cable-stayed bridges." *Computers & Structures* 52 (2): 309-321.

Sung Y. C., D. W. Chang, and E. H. Teo. 2006. "Optimum post-tensioning cable forces of Mau-Lo Hsi cable-stayed bridge." *Engineering Structures* 28: 1407–1417.

Sved, G., and Z. Ginos. 1968. "Structural optimization under multiple loading." *International Journal of Mechanical Sciences* 10 (10): 803-805.

Torii K, and K. Ikeda. 1987. "A study of the optimum design method for cable-stayed bridges." Paper presented at the International Conference on Cable-Stayed Bridges, Bangkok, Thailand.

Walther R., B. Houriet, W. Isler, P. Moia and J. F. Klein. 1999. *Cable-stayed bridges*. Second edition: Thomas Telford Publishing.

Wang, Pao-Hsii, and Chiung-Guei Yang. 1996. "Parametric studies on cable-stayed bridges." *Computers & Structures* 60 (2): 243-260.