

# Novi duh "stare uljare"

---

Žanetić, Karmen

**Supplement / Prilog**

*Publication year / Godina izdavanja:* **2021**

*Permanent link / Trajna poveznica:* <https://urn.nsk.hr/urn:nbn:hr:123:356493>

*Rights / Prava:* [In copyright](#)/[Zaštićeno autorskim pravom.](#)

*Download date / Datum preuzimanja:* **2024-10-02**



*Repository / Repozitorij:*

[FCEAG Repository - Repository of the Faculty of Civil Engineering, Architecture and Geodesy, University of Split](#)



UNIVERSITY OF SPLIT

  
DIGITALNI AKADEMSKI ARHIVI I REPOZITORIJI



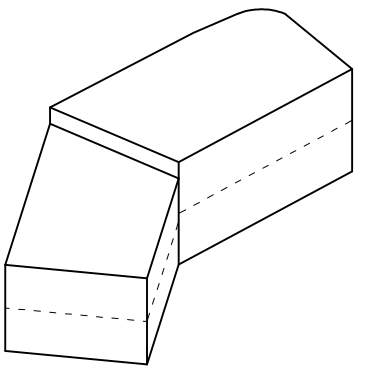

- postojeće stanje

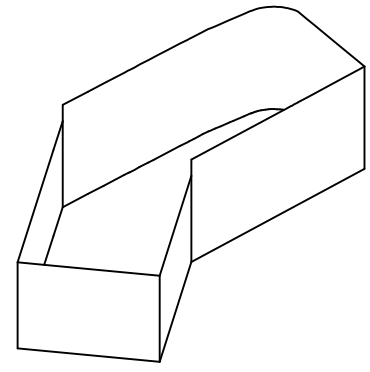

- očuvanje vanjskih gabarite zgrade  
- rušenje interijera

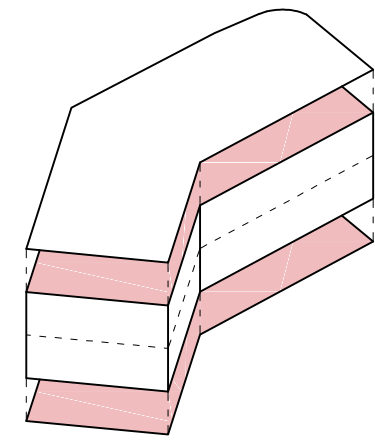

- dodavanje 2. etaže  
- iskopavanje podruma

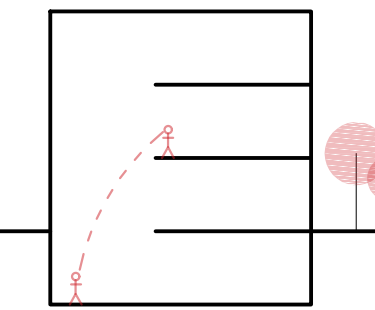

- vizualna povezanost prostora

KONCEPT

**KNJIŽNICA**  
JAVNO  
KULTURA

**ZAŠTIĆENO/UČENJE/  
KONCENTRACIJA**  
OTVORENO/DIJELENJE/RELAKSACIJA  
ZATVORENO/DOGAĐAJI/IZVOĐENJE

- stvaranje triju zona u jednoj zgradi

- različiti karakteri prostora

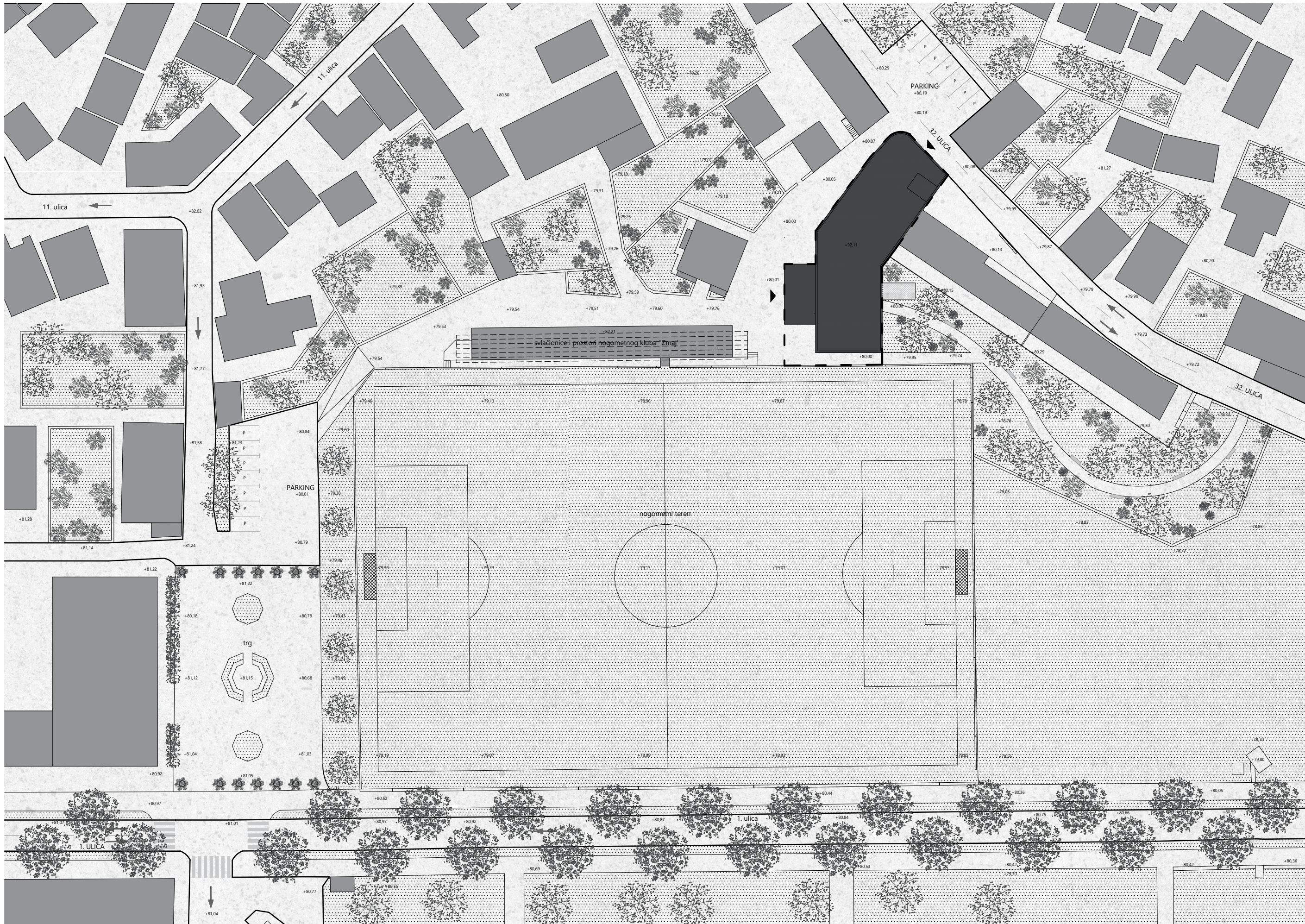

SITUACIJA

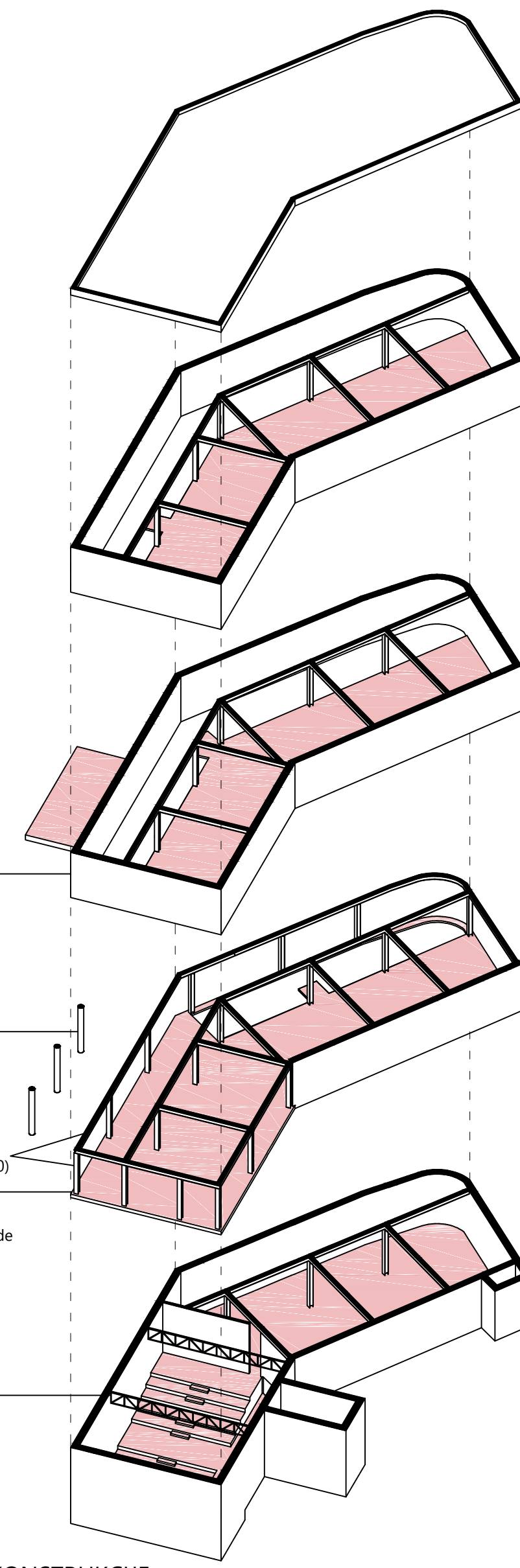

postojeći armirano-betonski zidovi

armirano-betonski stupovi

čelični stupovi (HEA 300) i grede (HEA 400)  
armirano-betonska ploča oslonjena na čelične stupove i grede

čelična rešetka

AKSONOMETRIJA KONSTRUKCIJE

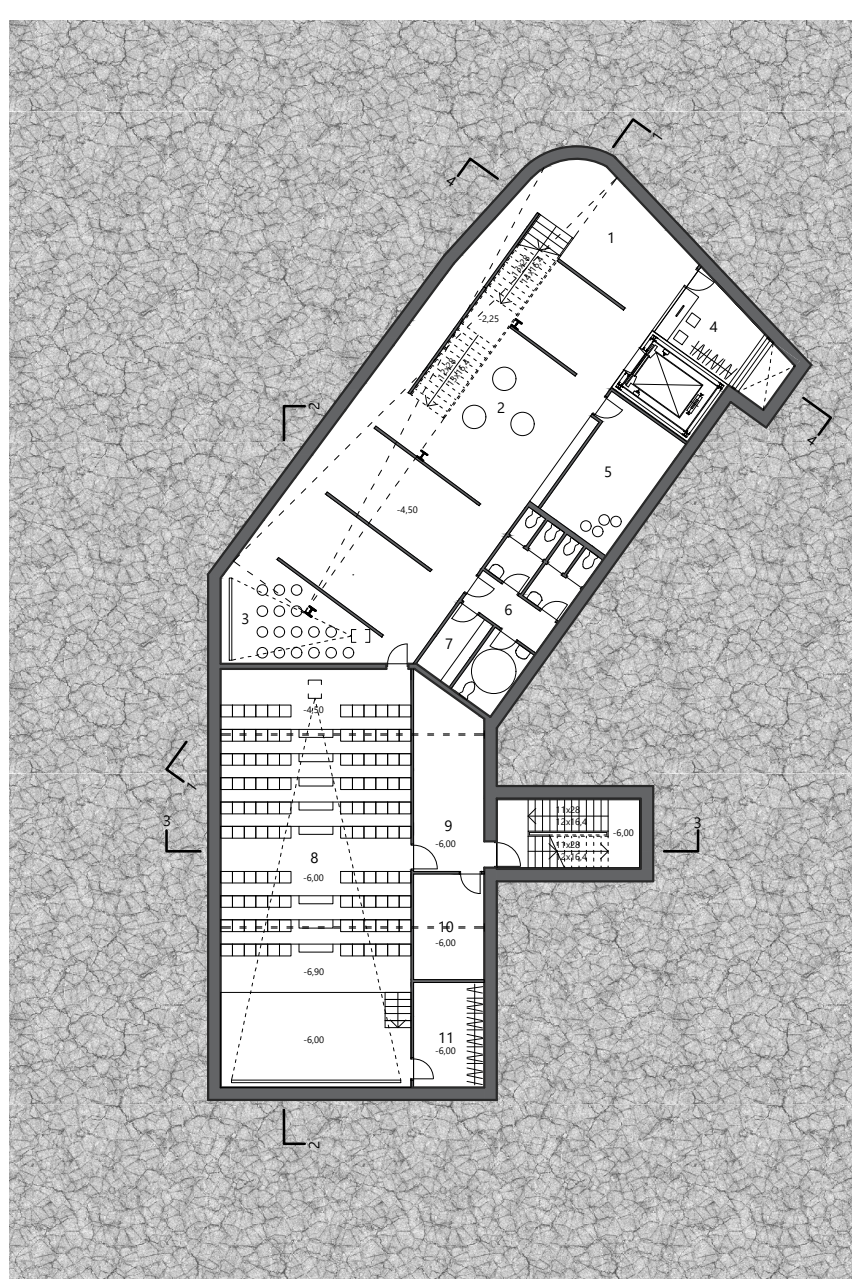

TLOCRT PODRUMA

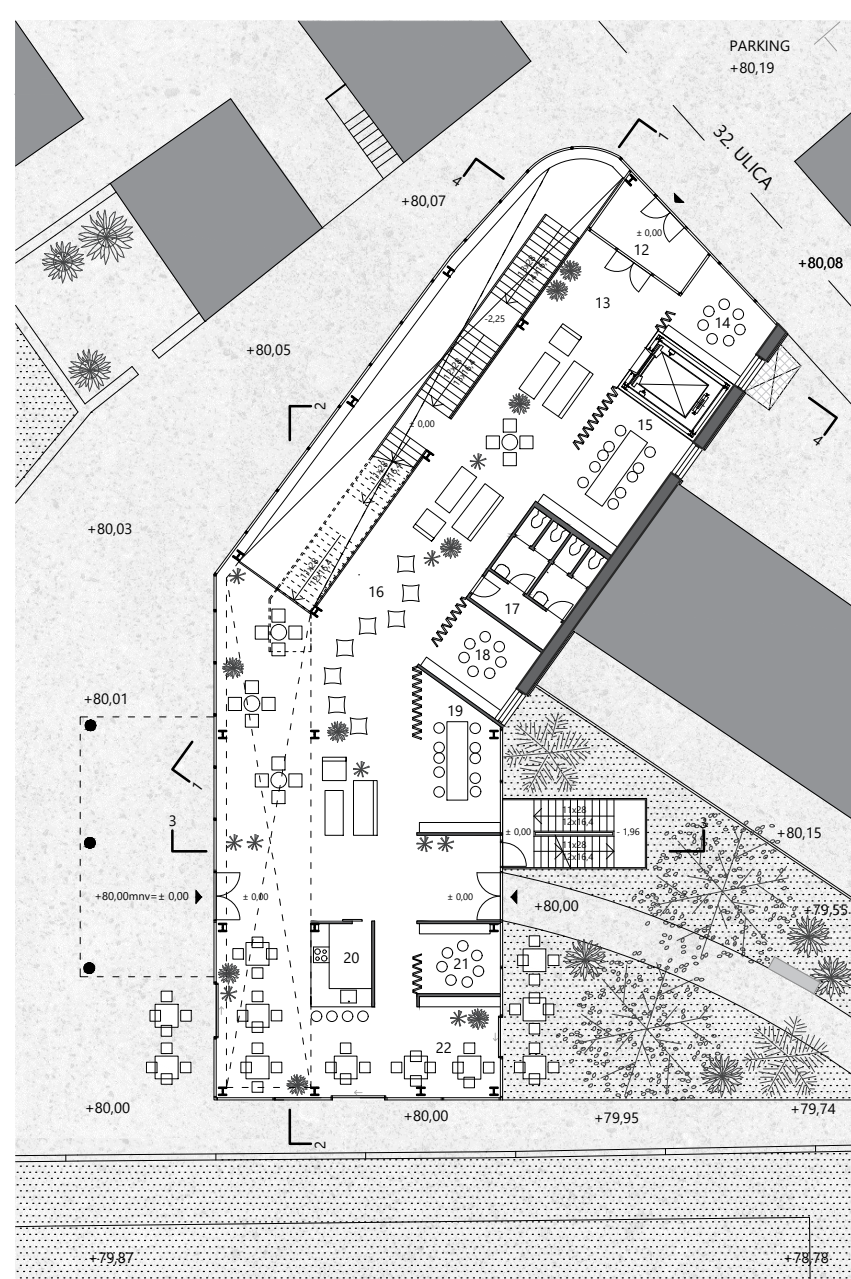

TLOCRT PRIZEMLJA

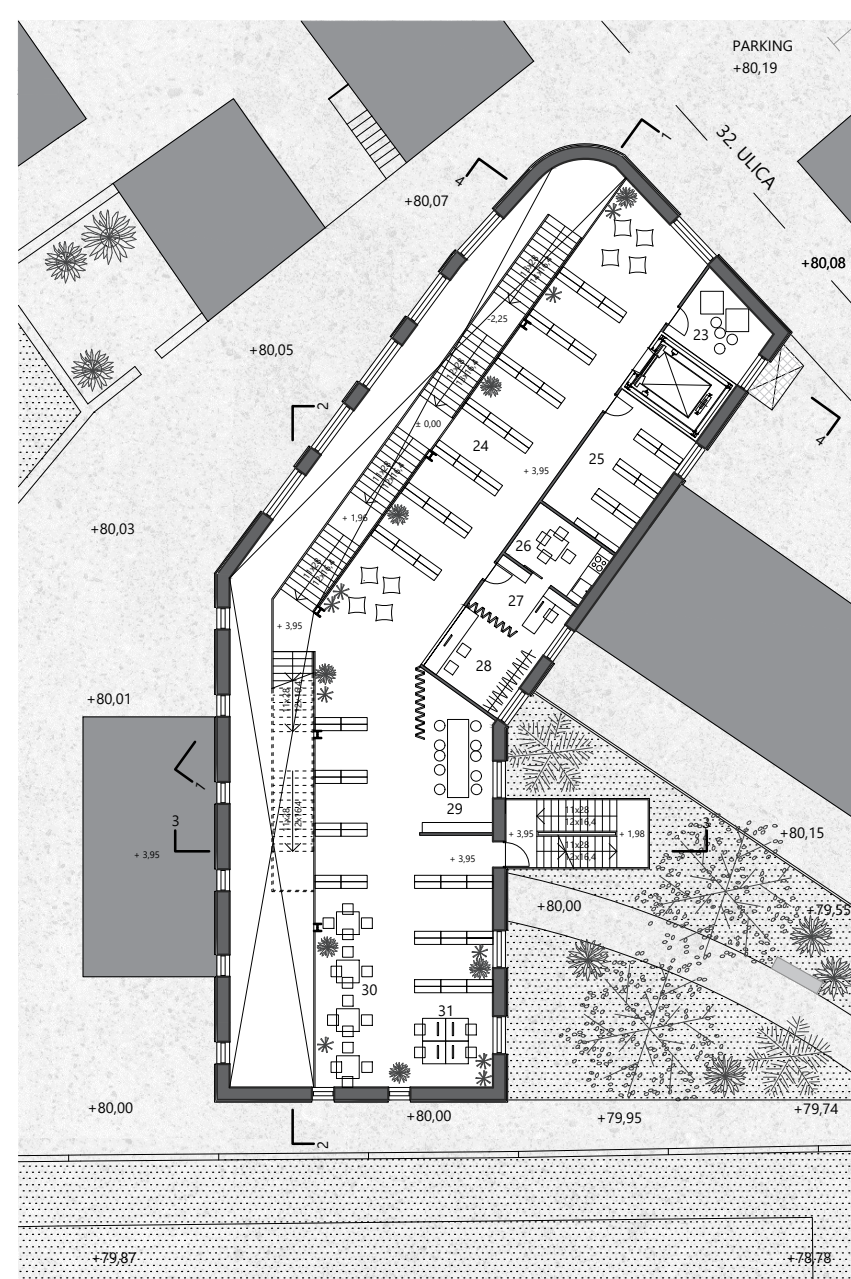

TLOCRT 1. KATA



PRESJEK 3-3



PRESJEK 2-2

**IME I PREZIME**  
**NASLOV DIPLOMSKOG RADA**  
**AKADEMSKA GODINA**  
**MENTOR**  
**KOMENTOR**  
**KONZULTANT**

**KARMEN ŽANETIĆ**  
**NOVI DUH "STARE ULJARE"**  
**2020 / 2021**  
**izv. prof. art. NIKOLA POPIĆ**  
**doc. dr. sc. HRVOJE BARTULOVIĆ**  
**izv. prof. dr. sc. NIKOLINA ŽIVALJIĆ**

Ovaj diplomski rad u fokus stavlja poimanje knjižnice kao "trećeg prostora" i kao "mjesto susreta" građana lokalne zajednice, a njegov cilj je prenamjena prostora "stare uljare" u Blatu na Korčuli u prostor Narodne knjižnice. Upravo Narodna knjižnica u Blatu sa svim svojim popratnim sadržajima postaje jedno takvo ležerno, društveno, ugodno i opuštено mjesto koje kod pojedinca razvija osjećaj pripadnosti zajednici i omogućava otvorenu komunikaciju o aktualnostima i problemima unutar zajednice. Takvo sigurno i inspirativno mjesto u kojemu se njeguje miran suživot, prihvaćanje, uključenost i tolerancija poticalo bi stanje mentalnog, fizičkog i socijalnog blagostanja pojedinca, lokalne zajednice, a time i društva u cjelini.

