

Novi duh "stare uljare"

Žanetić, Karmen

Supplement / Prilog

Publication year / Godina izdavanja: **2021**

Permanent link / Trajna poveznica: <https://urn.nsk.hr/urn:nbn:hr:123:356493>

Rights / Prava: [In copyright](#)/[Zaštićeno autorskim pravom.](#)

Download date / Datum preuzimanja: **2024-10-02**



Repository / Repozitorij:

[FCEAG Repository - Repository of the Faculty of Civil Engineering, Architecture and Geodesy, University of Split](#)



UNIVERSITY OF SPLIT

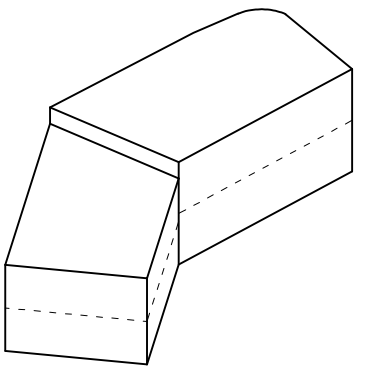

DIGITALNI AKADEMSKI ARHIVI I REPOZITORIJI

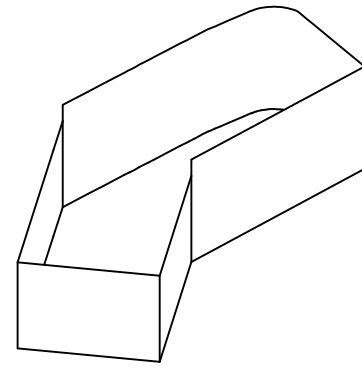

- postojeće stanje

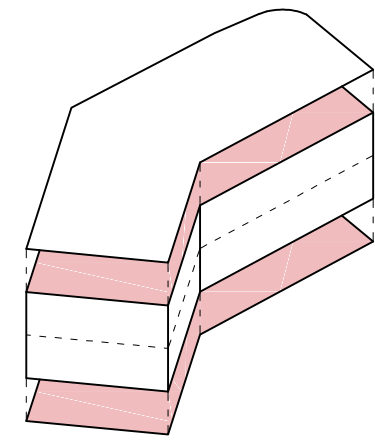

- očuvanje vanjskih gabarite zgrade
- rušenje interijera



- dodavanje 2. etaže
- iskopavanje podruma

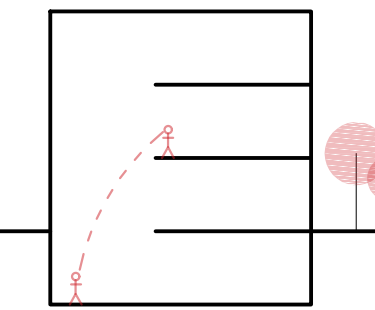

- vizualna povezanost prostora

KONCEPT

KNJIŽNICA
JAVNO
KULTURA

**ZAŠTIĆENO/UČENJE/
KONCENTRACIJA**
OTVORENO/DIJELENJE/RELAKSACIJA
ZATVORENO/DOGAĐAJI/IZVOĐENJE

- stvaranje triju zona u jednoj zgradi

- različiti karakteri prostora

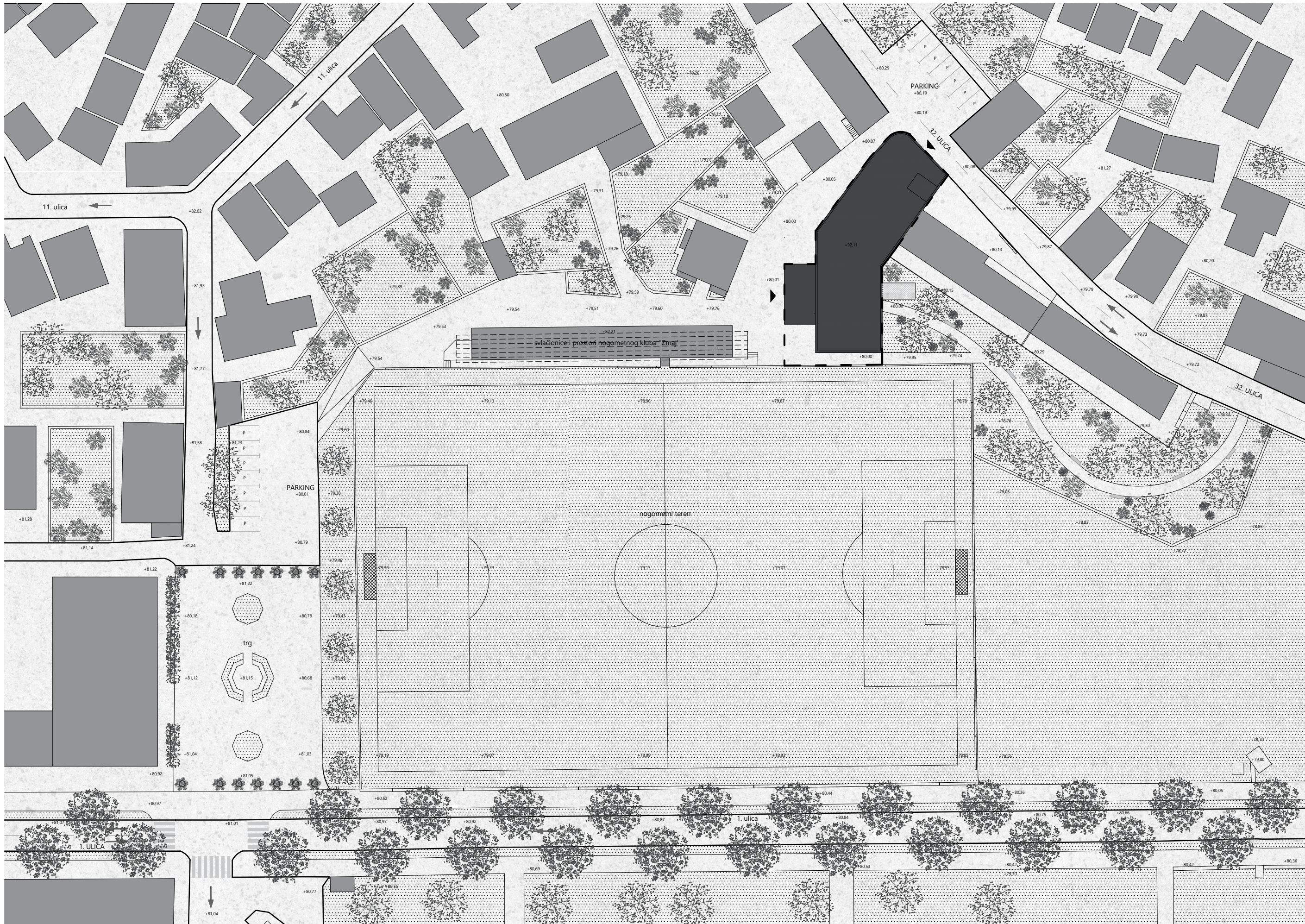

SITUACIJA

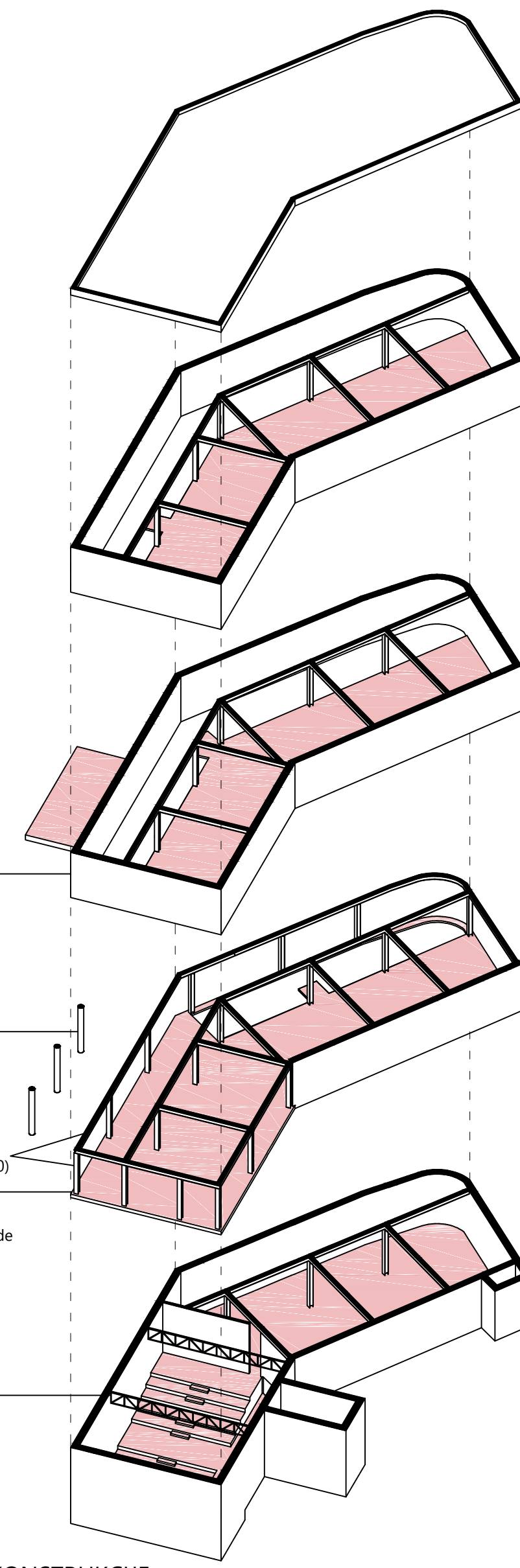

postojeći
armirano-betonski
zidovi

armirano-betonski
stupovi

čelični stupovi (HEA
300) i grede (HEA 400)
armirano-betonska
ploča oslonjena na
čelične stupove i grede

čelična rešetka

2. KAT

1. KAT

PRIZEMLJE

PODRUM

AKSONOMETRIJA KONSTRUKCIJE



PRESJEK 3-3



PRESJEK 2-2

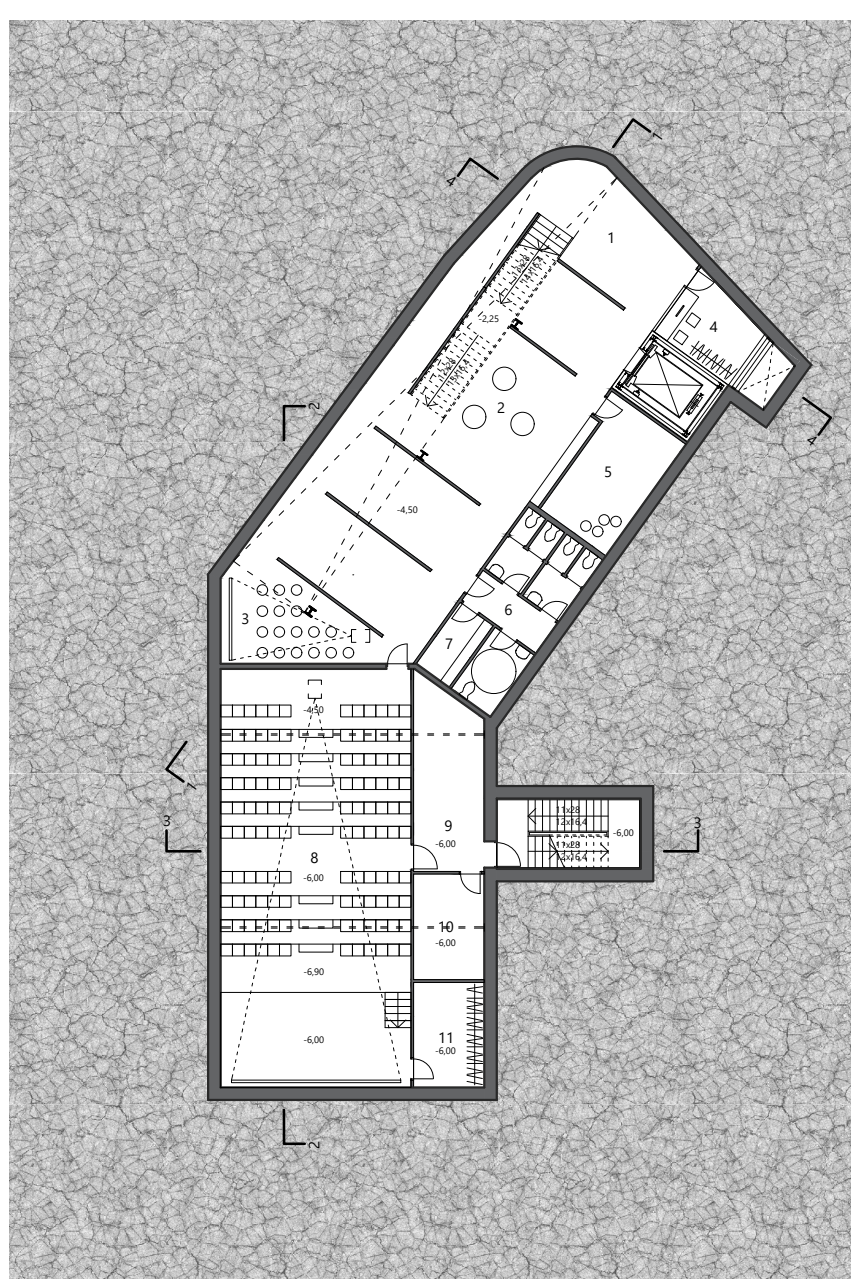

TLOCRT PODRUMA

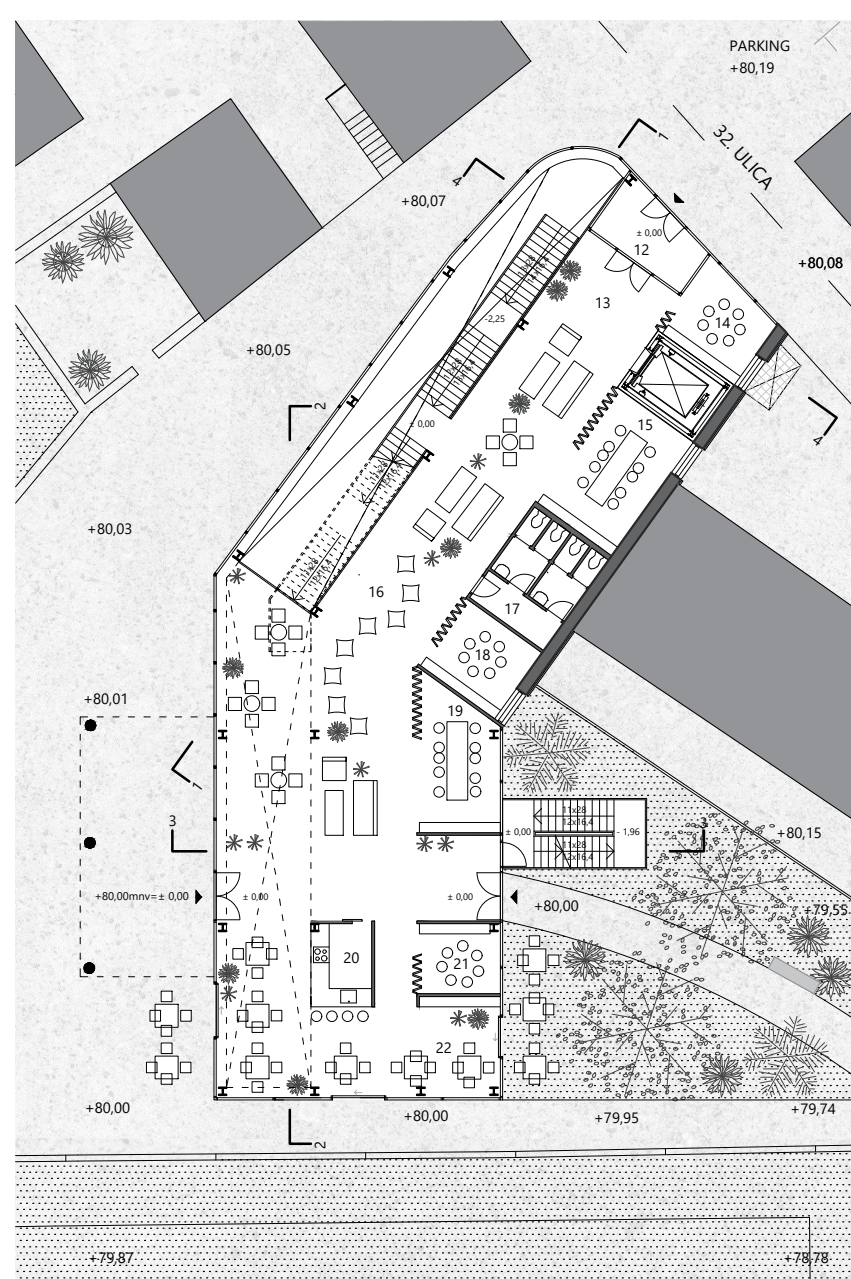

TLOCRT PRIZEMLJA

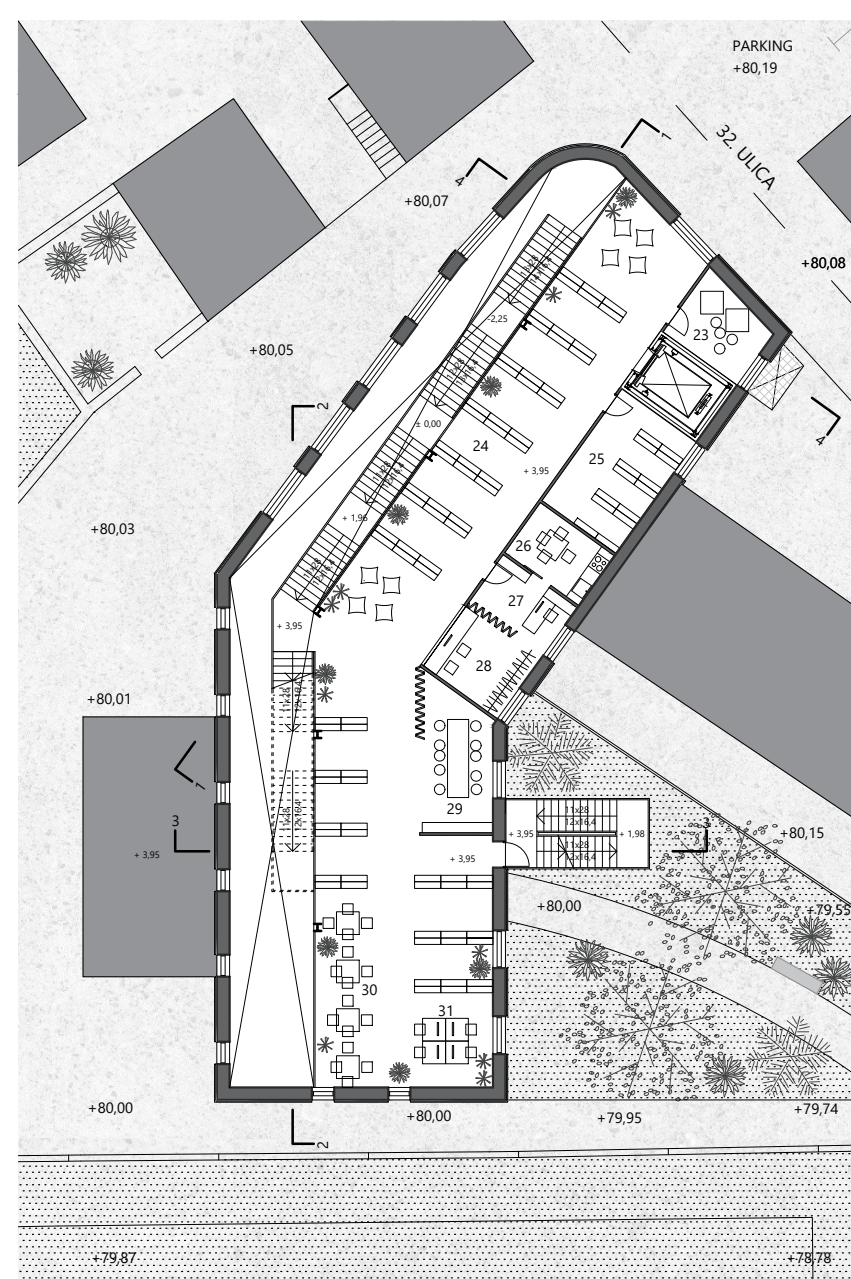

TLOCRT 1. KATA

IME I PREZIME
NASLOV DIPLOMSKOG RADA
AKADEMSKA GODINA
MENTOR
KOMENTOR
KONZULTANT

KARMEN ŽANETIĆ
NOVI DUH "STARE ULJARE"
2020 / 2021
izv. prof. art. NIKOLA POPIĆ
doc. dr. sc. HRVOJE BARTULOVIĆ
izv. prof. dr. sc. NIKOLINA ŽIVALJIĆ

Ovaj diplomski rad u fokus stavlja poimanje knjižnice kao "trećeg prostora" i kao "mjesto susreta" građana lokalne zajednice, a njegov cilj je prenamjena prostora "stare uljare" u Blatu na Korčuli u prostor Narodne knjižnice. Upravo Narodna knjižnica u Blatu sa svim svojim popratnim sadržajima postaje jedno takvo ležerno, društveno, ugodno i opuštено mjesto koje kod pojedinca razvija osjećaj pripadnosti zajednici i omogućava otvorenu komunikaciju o aktualnostima i problemima unutar zajednice. Takvo sigurno i inspirativno mjesto u kojemu se njeguje miran suživot, prihvaćanje, uključenost i tolerancija poticalo bi stanje mentalnog, fizičkog i socijalnog blagostanja pojedinca, lokalne zajednice, a time i društva u cjelini.

