

Statički proračun javne zgrade fakulteta

Pogančić, Igor

Undergraduate thesis / Završni rad

2021

Degree Grantor / Ustanova koja je dodijelila akademski / stručni stupanj:

University of Split, Faculty of Civil Engineering, Architecture and Geodesy / Sveučilište u Splitu, Fakultet građevinarstva, arhitekture i geodezije

Permanent link / Trajna poveznica: <https://um.nsk.hr/um:nbn:hr:123:695871>

Rights / Prava: [In copyright](#)/[Zaštićeno autorskim pravom.](#)

Download date / Datum preuzimanja: **2024-07-18**



Repository / Repozitorij:

[FCEAG Repository - Repository of the Faculty of Civil Engineering, Architecture and Geodesy, University of Split](#)



UNIVERSITY OF SPLIT



**SVEUČILIŠTE U SPLITU
FAKULTET GRAĐEVINARSTVA, ARHITEKTURE I GEODEZIJE**

ZAVRŠNI RAD

Igor Pogančić

Split, 2021.

SVEUČILIŠTE U SPLITU
FAKULTET GRAĐEVINARSTVA, ARHITEKTURE I GEODEZIJE

Statički proračun javne zgrade fakulteta

Završni rad

Split, 2021.

Statički proračun javne zgrade fakulteta

Sažetak:

U radu je prikazan statički proračun javne zgrade fakulteta. Zgrada se sastoji od prizemlja, tri etaže i ravnoga krova. Nosiva konstrukcija građevine će biti izvedena od armirano betonskih stupova, zidova i ploča. Projekt sadrži: tehnički opis, proračun nosivih konstrukcijskih elemenata i nacрте.

Ključne riječi:

Zgrada fakulteta, Statički proračun

Static calculation of public faculty building

Summary:

The static design of public faculty building is presented in this undergraduate work. The building consist of three stories, ground floor and flat roof. Structure is made of reinforced concrete consisting of beams, walls and plates. The work include technical description of the structure, calculation of the main structural elements as well as characteristic structural plans.

Keywords:

Faculty building, Static calculation

SVEUČILIŠTE U SPLITU

FAKULTET GRAĐEVINARSTVA, ARHITEKTURE I GEODEZIJE

Split, Matice hrvatske 15

STUDIJ: PREDDIPLOMSKI SVEUČILIŠNI STUDIJ GRAĐEVINARSTVA

KANDIDAT: Igor Pogančić

BROJ STUDENTSKE ISKAZNICE: 0083210296

KATEDRA: Katedra za teoriju konstrukcija

PREDMET: Građevna statika II

ZADATAK ZA ZAVRŠNI RAD

Tema: Statički proračun javne zgrade fakulteta

Opis zadatka: Na temelju zadane tlocrtno podloge, potrebno je izraditi proračunski model građevine. Na temelju dobivenih rezultata proračunavaju se određeni nosivi elementi zgrade, te za proračunate elemente potrebno je izraditi armaturne planove.

Izrađeni projekt mora sadržavati:

- tehnički opis
- proračun
- nacрте

U Splitu, veljača, 2021.

Voditelj Završnog rada: Prof.dr.sc. Boris Trogrlić, dipl.ing.građ.

SADRŽAJ

1. TEHNIČKI OPIS	7
1.1. Opis i konstrukcijski sastav građevine	7
1.2. Geotehnički izvještaj	7
2. 3-D PRORAČUNSKI MODEL GRAĐEVINE.....	8
3. ANALIZA OPTEREĆENJA.....	10
3.1. Podaci o osnovnim djelovanjima	10
3.2. Stalno opterećenje (G_1)	10
3.2.1. Vlastita težina elemenata konstrukcije.....	10
3.2.2. Krovna ploča	11
3.2.3. Međukatne ploče	12
3.2.4. Stubište	13
3.3. Promjenjivo opterećenje (Q_i)	13
4. PRIKAZ OSNOVNIH DJELOVANJA	14
4.1. Krovna ploča	14
4.2. Međukatna ploča	15
4.3. Stubište	16
5. KOMBINACIJE DJELOVANJA	17
6. PRORAČUN PLOČA	18
6.1. Proračun međukatne ploče	18
6.1.1. Prikaz modela i rezultata međukatne ploče.....	19
6.1.2. Kontrola progiba i pukotina međukatne ploče	22
6.1.2.1. Kontrola progiba međukatne ploče	22
6.1.2.2. Kontrola pukotina.....	24
6.2. Proračun krovne ploče.....	27
6.2.1. Prikaz modela i rezultata krovne ploče	28
6.2.2. Kontrola progiba krovne ploče.....	31
6.2.3. Kontrola pukotina krovne ploče.....	33
7. PRORAČUN AB GREDA.....	36

7.1. Međukatna greda	36
7.1.1. Prikaz rezultata proračuna.....	36
7.1.2. Dimenzioniranje na moment savijanja.....	37
7.1.3. Dimenzioniranje na poprečnu silu	39
7.1.4. Kontrola progiba	41
7.1.5. Kontrola pukotina	43
7.2. Krovna greda.....	45
7.2.1. Prikaz rezultata proračuna.....	45
7.2.2. Dimenzioniranje na moment savijanja.....	46
7.2.3. Dimenzioniranje na poprečnu silu	48
7.2.4. Kontrola progiba	50
7.2.5. Kontrola pukotina	51
8. PRORAČUN ZIDOVA.....	53
9. PRORAČUN STUPOVA.....	57
10. PRORAČUN STUBIŠTA.....	59
10.1. Mjerodavne rezne sile	59
10.2. Dimenzioniranje stubišta.....	60
11. PRORAČUN TEMELJA SAMCA ISPOD STUPA	62
11.1. Dimenzioniranje temeljnih stopa	62
11.2. Proračun armature temelja	64
12. GRAFIČKI PRILOZI	65
13. LITERATURA	70

1.TEHNIČKI OPIS

1.1 Opis i konstrukcijski sastav građevine

Predmet ovog završnog rada je proračun nosive konstrukcije građevine poslovne namjene. Građevina se sastoji od ukupno četiri etaže, nepravilnog je tlocrtnog oblika – dimenzija 30.40 x 58.30 m. Ukupna visina građevine iznosi 14.94 m mjereno od podne ploče prizemlja. Glavni nosivi konstrukcijski sustav sastoji se od armirano-betonskih (AB) zidova i stupova te međukatnih konstrukcija koje su izrađene od armiranog betona, lijevane na licu mjesta debljine 18cm.

Stubišta su također izvedena u armiranom betonu debljine 18 cm.

Ravna krovna ploča je debljine 18 cm i izvedena je od armiranog betona.

Vertikalna nosiva konstrukcija građevine su zidovi debljine 30 cm i 40 cm, te stupovi dimenzija 40x40 cm, 70x40 cm, 70x60 cm

Temeljenje je predviđeno na temeljnim stopama, trakastim temeljima i temeljnih ploča od armiranog betona ispod nosivih zidova i stupova.

U proračunu su dane osnovne dimenzije armature za pojedine konstruktivne elemente.

Elementi koji se ne proračunavaju armiraju se konstruktivno.

Za sve betonske radove predviđen je beton C 30/37 (MB-40), te armatura B 500.

Skidanje podupirača za ploče može se izvršiti nakon postignute minimalne čvrstoće od 80%. Za temelje je upotrebljena klasa betona C 30/37 (MB-30).

Svi računalni proračuni su izvršeni u programu „Scia Engineer“. Svi ostali podaci i detalji vezani za objekt dani su kroz projektna rješenja.

1.2 Geotehnički izvještaj

Za predmetnu građevinu su izvršeni geotehnički istražni radovi.

Matična stijena nalazi se na oko 85 cm od površine terena, temeljenje građevine će se izvesti na njoj. Pri završetku iskopa temeljnu plohu potrebno je ručno očistiti od ostataka razlomljenog materijala.

Nakon obavljenog čišćenja temeljne plohe potrebno je neravnine i udubine popuniti i izravnati podložnim betonom C 16/20 (MB-20) do projektirane kote temeljenja.

Ukoliko se naiđe na kavernu veće dubine i manje širine, a nije moguće potpuno uklanjanje materijala, sanaciju izvesti tako da se materijal ukloni do dubine 50 cm ispod kote temeljenja, a nastali prostor do projektirane kote zapuni podbetonom. Na osnovu rezultata geotehničkih istražnih radova, dopuštena centrična naprezanja tla na detaljno očišćenim naslagama matične stijene uzeta su za osnovna opterećenja 500 kPa

2. 3-D PRORAČUNSKI MODEL GRAĐEVINE



Slika 2.1 Proračunski model objekta – pogled 1

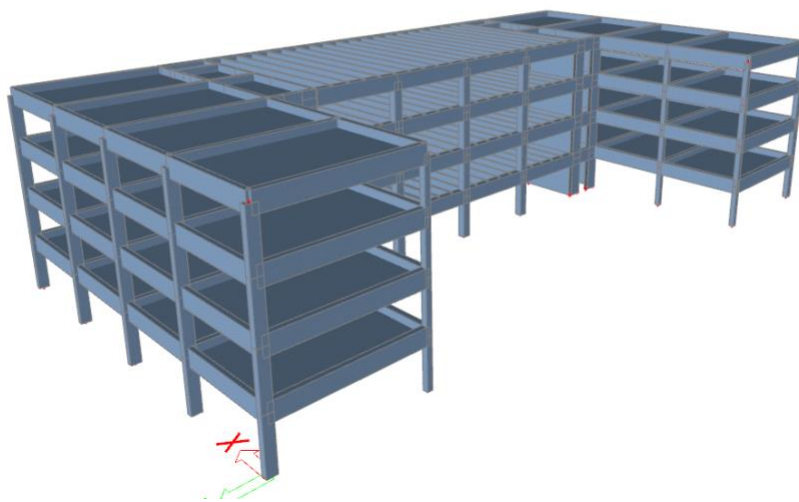

Slika 2.2 Proračunski model objekta – pogled 2

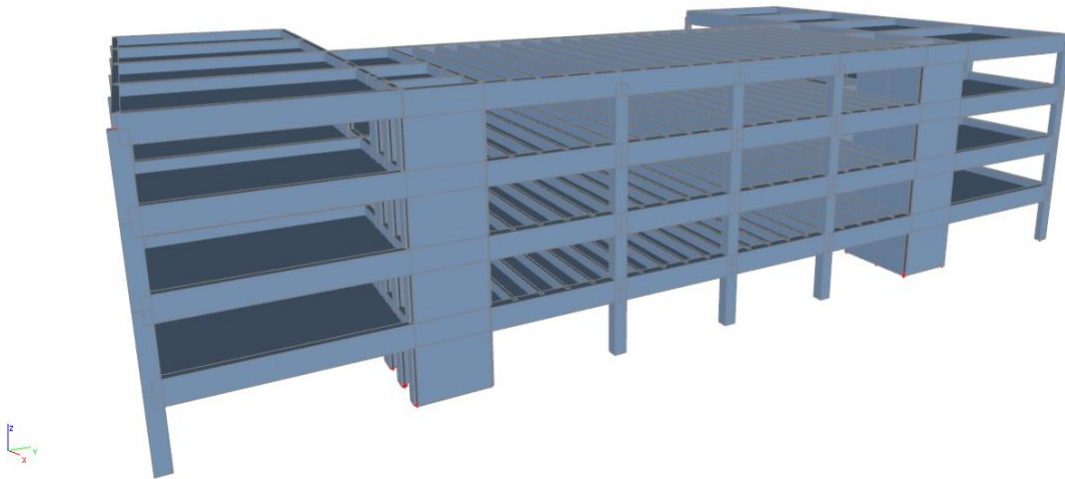

Slika 2.3 Proračunski model objekta – pogled 3

3. ANALIZA OPTEREĆENJA

3.1. Podaci o osnovnim djelovanjima

Osnovna opterećenja, na čiji utjecaj se dokazuje mehanička otpornost i stabilnost predmetne građevine, podijeljena su:

Oznaka osnovnog djelovanja	Opis djelovanja
G0	Stalno djelovanje – vlastita težina elemenata nosive konstrukcije (uračunata u SCIA-u)
G1	Dodatno stalno djelovanje – ostalo stalno djelovanje; pokrov, obloga, stalna oprema itd.
Qi	Promjenjivo – uporabno djelovanje: uporabno opterećenje, pokretna oprema.
W	Vjetar
S	Snijeg

Tablica 3.1 Podaci o osnovnim djelovanjima

3.2. Stalno opterećenje (G1)

3.2.1. Vlastita težina elemenata konstrukcije

Stalno opterećenje uključeno je u proračun prema sljedećem:

- Specifična težina armiranog betona iznosi $g = 30.0 \text{ kN/m}^3$.
- Stalno opterećenje od vlastite težine elemenata armirano betonske konstrukcije sadržano je u proračunskom modelu, sukladno dimenzijama poprečnih presjeka i zadanoj specifičnoj težini.

3.2.2. Krovna ploča

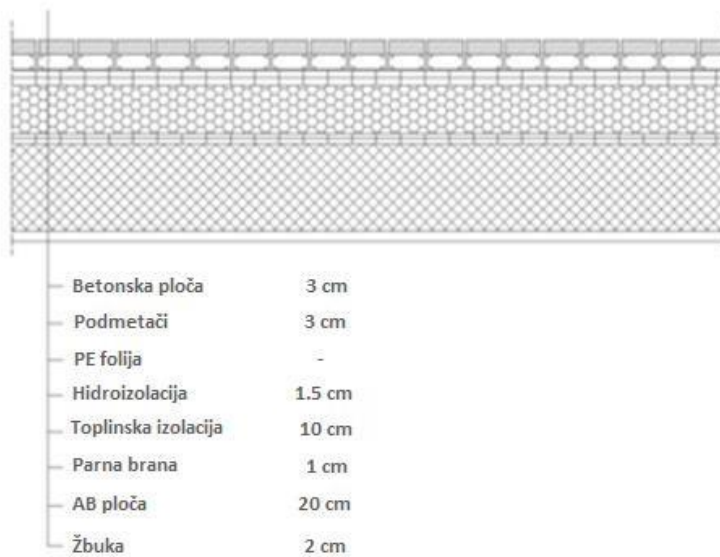

Tablica 3.2.1 Slojevi ravnog krova

Sloj:	Debljina sloja (m):	γ (kN/m ³)	$d \times \gamma$ (kN/m ²)
Betonska ploča	0,03	25,00	0,75
Podmetači	0,03	-	-
PE folija	-	-	-
Hidroizolacija	0,015	5,90	0,09
Toplinska izolacija	0,10	1,50	0,30
Parna brana	0,01	0,15	0,0015
AB ploča	0,20	Uključena u SCIA-u	
Žbuka	0,02	19,00	0,38

Ukupno dodatno stalno opterećenje: $\Delta g = 1,52$ (kN/m²)

3.2.3. Međukatne ploče

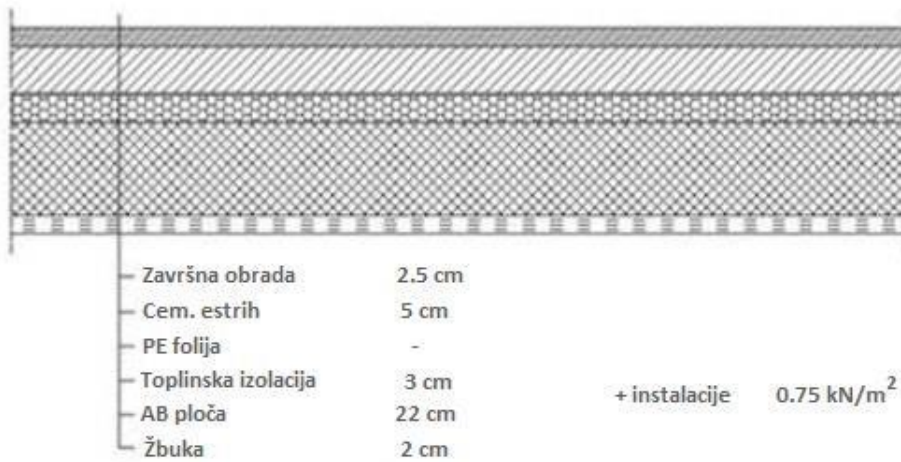

Tablica 3.2.2 Slojevi poda međukatnih konstrukcija

Sloj:	Debljina sloja (m):	γ (kN/m ³)	$d \times \gamma$ (kN/m ²)
Završna obrada	0,025	9,60	0,24
Cementni estrih	0,05	22,00	1,10
PE folija	-	-	-
Toplinska izolacija	0,03	2,00	0,015
AB ploča	0,18	Uključeno u SCIA-u	
Žbuka	0,02	0,02	0,38
Instalacije	-	-	0,75

Ukupno dodatno stalno opterećenje: $\Delta g = 2,50$ (kN/m²)

3.2.4. Stubište

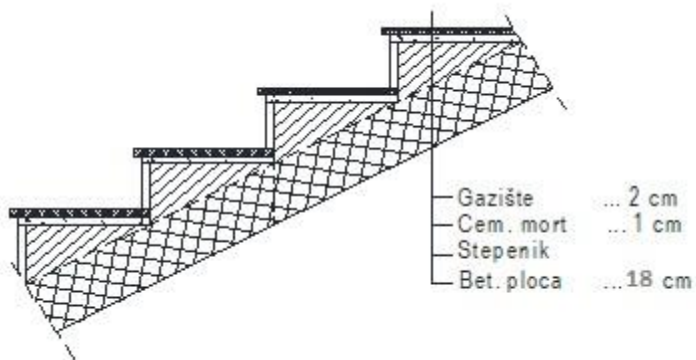

Tablica 3.2.4 Slojevi poda stubišta

Sloj:	Debljina sloja (m):	γ (kN/m ³)	$d \times \gamma$ (kN/m ²)
Kamene ploče	0,02	28,00	0,56
Cementni mort	0,01	20,00	0,20
Stube	0,07	24,00	1,68
AB ploča	0,18	Uključeno u SCIA-u	

Ukupno dodatno stalno opterećenje: $\Delta g = 2,50$ (kN/m²)

3.3. Promjenjivo opterećenje (Qi)

Minimalno korisno opterećenje za zgrade definirano je u EC1991-1-1. Ovo korisno (pokretno) opterećenje je najmanje koje se smije primjeniti na zgradama. Na zahtjev investitora ili pri procjeni projektanta smije se koristiti i veće opterećenje. Za potrebe proračuna, a prema EC1991-1-1 korištena su sljedeća opterećenja:

- Ravni krov: $q = 1,0$ kN/m²
- Poslovni prostori i stubišta: $q = 3,0$ kN/m²
- Stubišta: $q = 3,0$ kN/m²
- Balkoni i lođe: $q = 4,0$ kN/m²

4. PRIKAZ OSNOVNIH DJELOVANJA

4.1. Krovna ploča

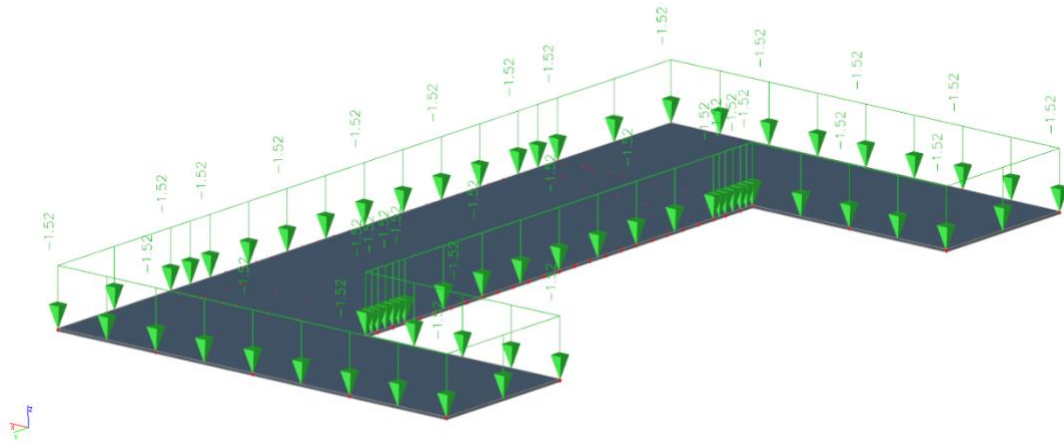

Slika 4.1.1 Dodatno stalno djelovanje $G1$ [kN/m^2]

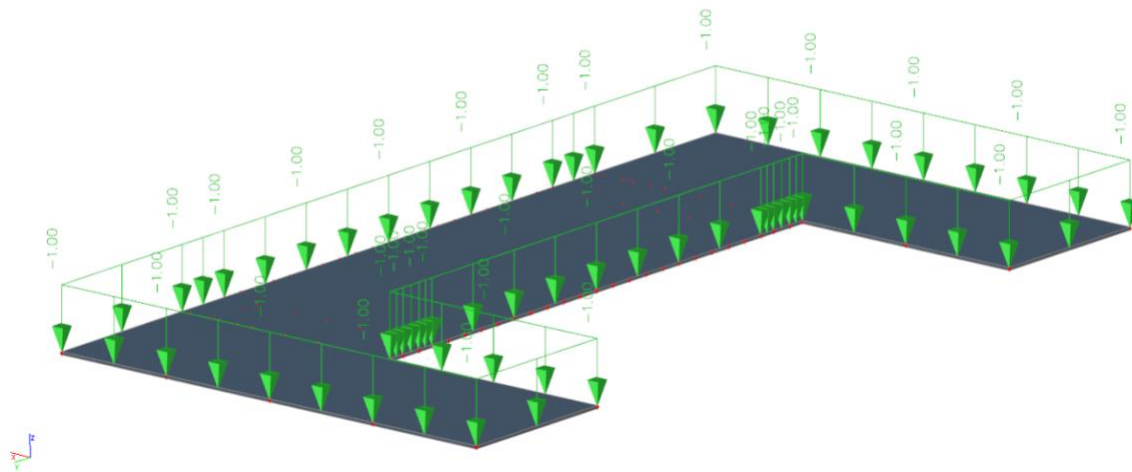

Slika 4.1.2 Promjenjivo djelovanje Q [kN/m^2]

4.2. Međukatna ploča

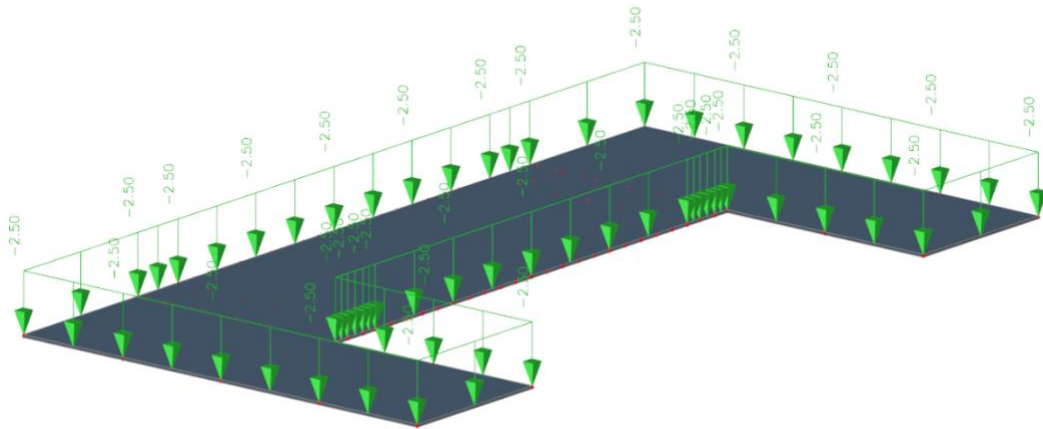

Slika 4.2.1 Dodatno stalno djelovanje $G1$ [kN/m²]

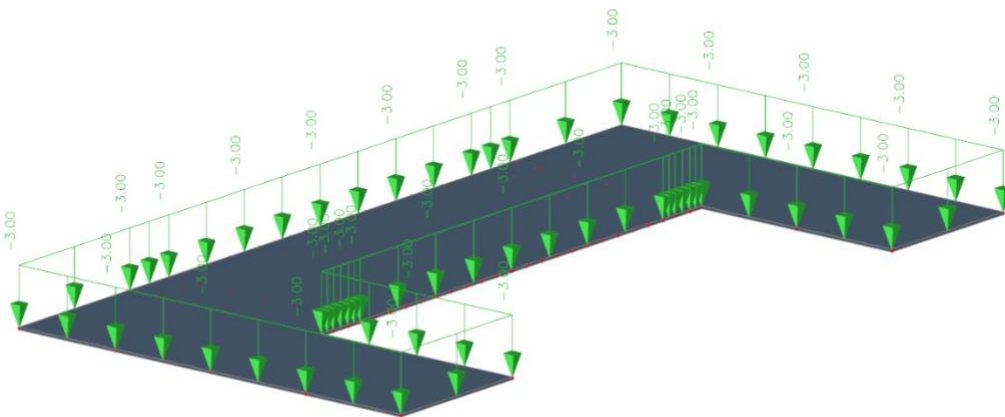

Slika 4.2.2 Promjenjivo djelovanje Q [kN/m²]

4.3. Stubište

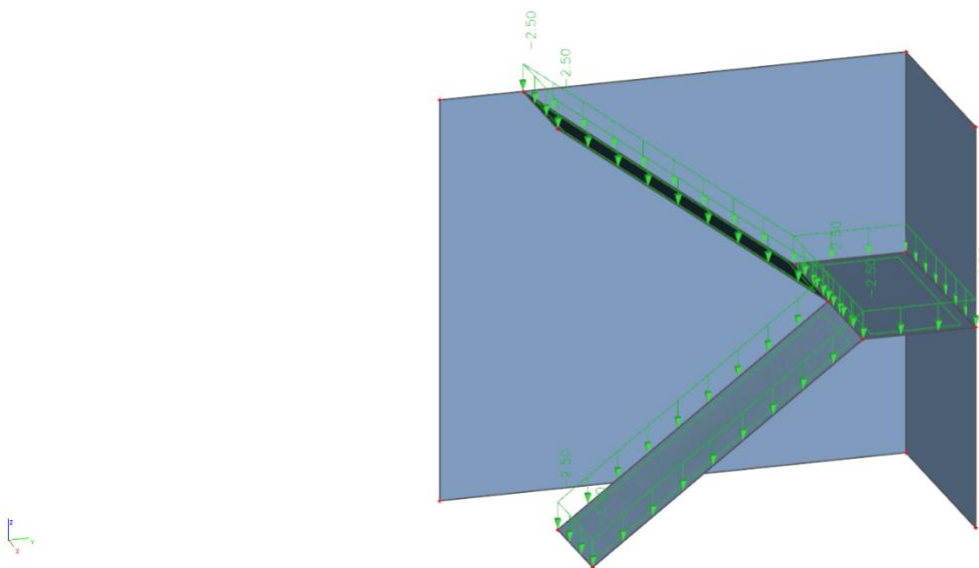

Slika 4.3.1 Dodatno stalno djelovanje $G1$ [kN/m^2]

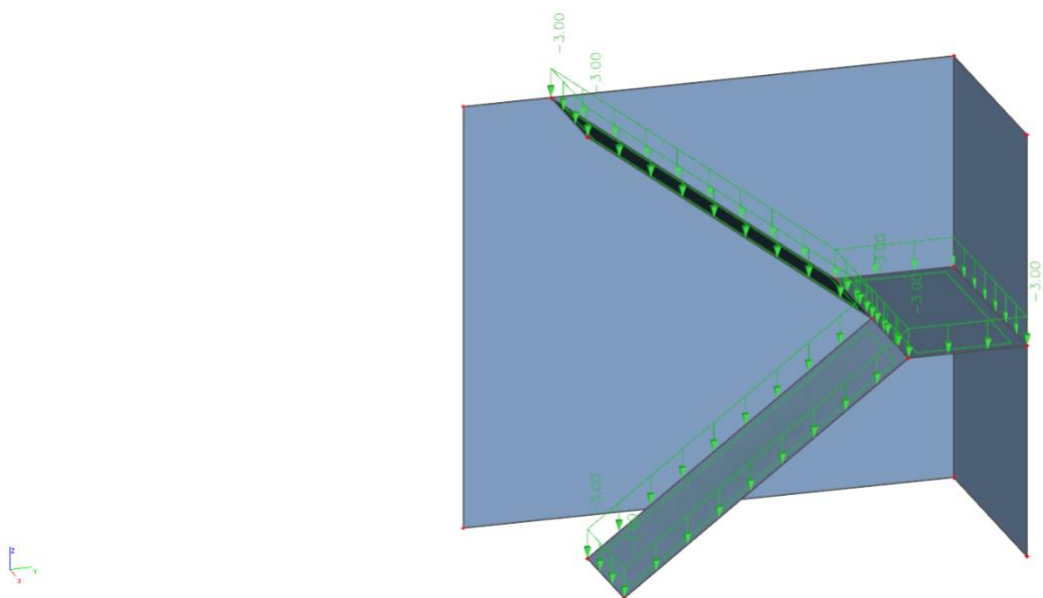

Slika 4.3.2 Promjenjivo djelovanje Q [kN/m^2]

5. KOMBINACIJE DJELOVANJA

Za dokaz nosivosti elemenata konstrukcije predmetne građevine, djelovanja se kombiniraju za sljedeća granična stanja i iznose:

Granično stanje nosivosti

$$\text{GSN-1 } 1.35 \cdot G + 1.35 \cdot G_1 + 1.5 \cdot Q$$

G – vlastita težina + dodatno stalno djelovanje

*vlastita težina je uračunata u programu SCIA Engineer

Q – uporabno djelovanje

Granično stanje uporabljivosti

$$\begin{aligned} \text{GSU-1 (česta kombinacija)} \quad & 1.0 \cdot G + \Psi_{1i} \cdot Q \\ & 1.0 \cdot G + 0.5 \cdot Q \end{aligned}$$

$\Psi_{1i} = 0.5$ za promjenjiva djelovanja u poslovnim zgradama za čestu kombinaciju.

Česta kombinacija se koristi za kontrolu progiba ploča i greda, te za kontrolu pukotina ploča i greda.

$$\begin{aligned} \text{GSU-2 (nazovistalna kombinacija)} \quad & 1.0 \cdot G + \Psi_{2i} \cdot Q \\ & 1.0 \cdot G + 0.3 \cdot Q \end{aligned}$$

$\Psi_{2i} = 0.3$ za promjenjiva djelovanja u poslovnim zgradama za nazovistalnu kombinaciju.

Nazovistalna kombinacija se koristi za ograničenje tlačnog naprezanja u armirano betonskim elementima, te za kontrolu dugotrajnih progiba.

6. PRORAČUN PLOČA

6.1. Proračun međukatne ploče

Limitirajući moment:

$$M_{Rd,lim} = \mu_{Sd,lim} \cdot b_w \cdot d^2 \cdot f_{cd} = 0.159 \cdot 1.0 \cdot 0.15^2 \cdot 20 \cdot 1000 = 71.55 \text{ kNm}$$

Minimalna i maksimalna armatura:

$$A_{s,min} = 0.0015 \cdot b \cdot d = 0.0015 \cdot 100 \cdot 15 = 2.25 \text{ cm}^2 / m$$

$$A_{s,min} = 0.006 \cdot b \cdot \frac{d}{f_{yd}} = 0.06 \cdot 100 \cdot \frac{15}{500} = 1.8 \text{ cm}^2 / m$$

$$A_{s,max} = 0.31 \cdot b \cdot d \cdot \frac{f_{cd}}{f_{yd}} = 0.31 \cdot 100 \cdot 15 \cdot \frac{20}{434.80} = 21.39 \text{ cm}^2 / m$$

Za proračun armature usvaja se $\zeta \approx 0.9$, potrebna armatura :

$$A_{s1} = \frac{M_{ed}}{\zeta \cdot d \cdot f_{yd}} = \frac{M_{ed} \cdot 100}{0.9 \cdot 15 \cdot 43.5} = M_{ed} \cdot 0.17$$

Računska nosivost na poprečnu silu bez poprečne armature :

$$V_{Rd,c} = [C_{Rdc} \cdot k \cdot (100 \cdot \rho_l \cdot f_{ck})^{1/3} + k_1 \cdot \vartheta_{cp}] \cdot b_w \cdot d$$

$$k = 1.0 + \sqrt{\frac{200}{d}} = 1.0 + \sqrt{\frac{200}{150}} = 1.15 < 2.0 \rightarrow k = 2.0$$

$$k_1 = 0.15$$

$$\vartheta_{cp} = \frac{N_{ed}}{A_s} = 0.0$$

$$C_{Rdc} = \frac{0.18}{\gamma_c} = \frac{0.18}{1.5} = 0.12$$

$$\rho_l = \frac{\sum A_s}{A_c} = \frac{3.35}{15 \cdot 100} = 0.0023$$

$$V_{Rd,c} = [0.12 \cdot 2.0 \cdot (100 \cdot 0.0018 \cdot 30)^{1/3} + 0.15 \cdot 0.0] \cdot 1000 \cdot 150$$

$$V_{Rd,c} = 63.16 \text{ kN/m}$$

$$V_{Rd,c,min} = [v_{min} + k_1 \cdot \vartheta_{cp}] \cdot b_w \cdot d$$

$$k = 0.15$$

$$v_{min} = 0.035 \cdot k^{3/2} \cdot f_{ck}^{1/2} = 0.035 \cdot 2.0^{3/2} \cdot 30^{1/2} = 0.542$$

$$\vartheta_{cp} = \frac{N_{ed}}{A_c} = 0$$

$$V_{Rd,c,min} = 0.542 \cdot 1000 \cdot 150 = 81.30 \text{ kN/m}$$

6.1.1. Prikaz modela i rezultata međukatne ploče

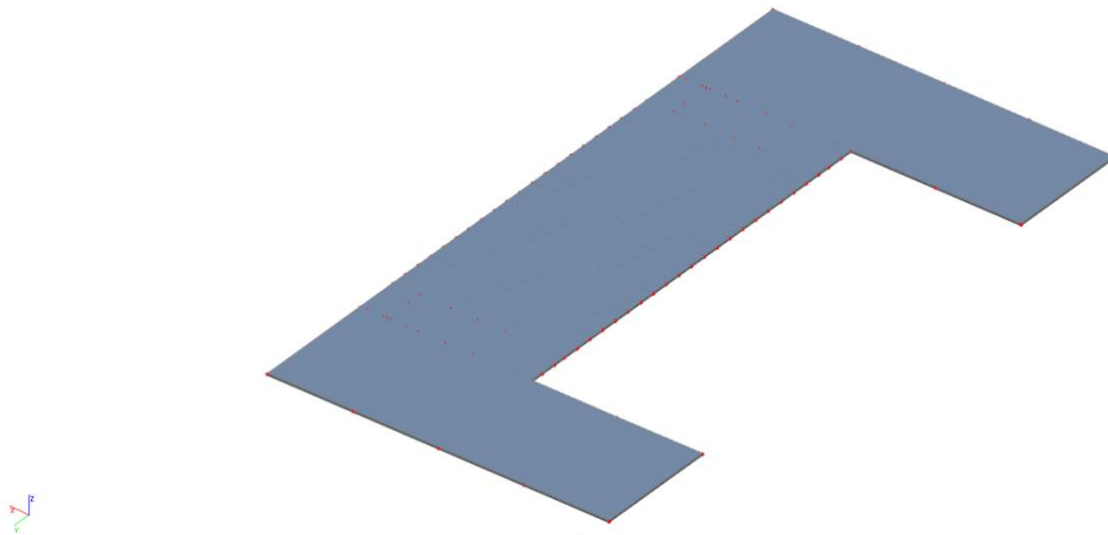

Slika 6.1.1 Prikaz modela ploče

2D internal forces
Values: m_x
Linear calculation
Combination: GSN1
Extreme: Global
Selection: All
Location: In nodes avg., System: LCS
mesh element

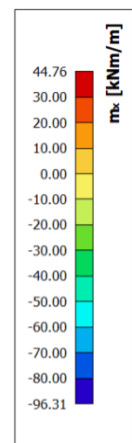

Slika 6.1.2 Moment savijanja $M_{Ed,x}$ (kNm/m) za GSN-1

2D internal forces
 Values: m_y
 Linear calculation
 Combination: GSN1
 Extreme: Global
 Selection: All
 Location: In nodes avg., System: LCS
 mesh element

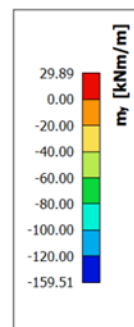

Slika 6.1.3 Moment savijanja $M_{Ed,y}$ (kNm/m) za GSN-1

2D internal forces
 Values: v_x
 Linear calculation
 Combination: GSN1
 Extreme: Global
 Selection: All
 Location: In nodes avg., System: LCS
 mesh element

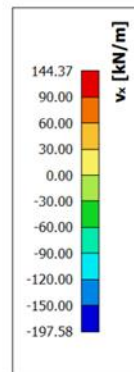
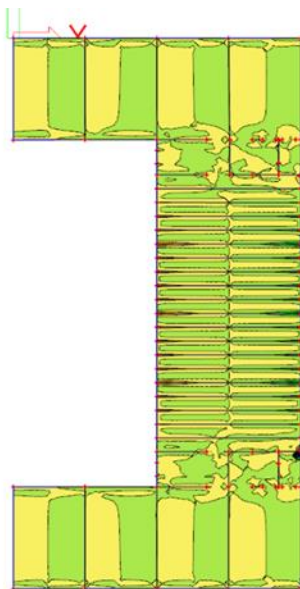

Slika 6.1.4 Poprečne sile $V_{Ed,x}$ (kN/m) za GSN-1

2D internal forces

Values: v_y
 Linear calculation
 Combination: GSN1
 Extreme: Global
 Selection: All
 Location: In nodes avg., System: LCS
 mesh element

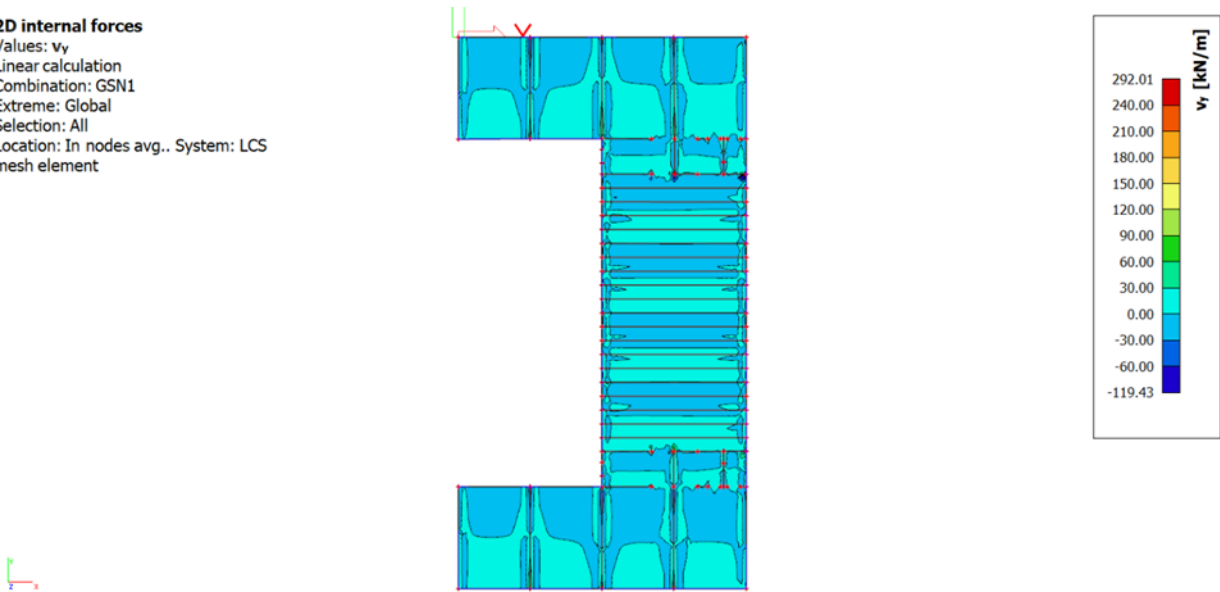

Slika 6.1.5 Poprečne sile $V_{Ed,y}$ (kN/m) za GSN-1

Potrebna površina armature:

Potrebna armatura u polju:

$$A_s = \frac{44.76 \cdot 100}{0,9 \cdot 15 \cdot 43.5} = 7.62 \text{ cm}^2/\text{m}'$$

Potrebna armatura u ležaju:

$$A_s = \frac{96.31 \cdot 100}{0,9 \cdot 15 \cdot 43.5} = 16.4 \text{ cm}^2/\text{m}'$$

Napomena: armaturu u polju povećati za 20%, dok armaturu and ležajem smanjiti za 15%

$$7.62 \times 1.2 = 9.14 \text{ cm}^2/\text{m}'$$

$$16.4 \times 0.85 = 13.94 \text{ cm}^2/\text{m}'$$

Odabrana armatura:

Polje: Q-785+2 ϕ 12 (10.11 cm^2/m')

Ležaj: R-785+6 ϕ 12 (14.64 cm^2/m')

6.1.2. Kontrola progiba i pukotina međukatne ploče

S obzirom da je model građevine modeliran na temeljnom tlu realnih karakteristika cijela građevina će imati pomake određenih vrijednosti, pa tako i međukatne ploče. Zbog nemogućnosti prikazivanja relativnih pomaka ploča bit će prikazani ukupni pomaci ploča koji nisu mjerodavni za analizu.

Kako bismo dobili pomake koji će prikazati pravo ponašanje ploče od ukupnih pomaka oduzet ćemo translacijsku komponentu pomaka, te na taj način dobivamo deformacijsku komponentu pomaka koja će se analizirati.

6.1.2.1. Kontrola progiba međukatne ploče

2D displacement
Values: u_z
Linear calculation
Combination: GSU1
Extreme: Global
Selection: All
Location: In nodes avg. on macro.
System: LCS mesh element

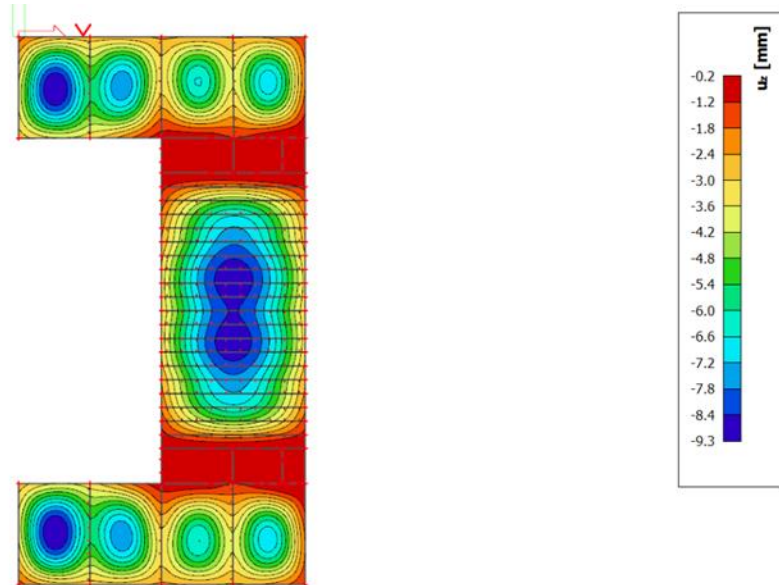

Slika 6.1.6 Progib ploče (mm) za kombinaciju GSU-1

Najveći progib iznosa je $9.3 - 0.2 = 9.1$ mm
Dozvoljen progib $L/1000 = 10000/1000 = 10$ mm
Međukatna ploča zadovoljava na progibe.

2D displacement
Values: u_z
Linear calculation
Combination: GSU2
Extreme: Global
Selection: All
Location: In nodes avg. on macro.
System: LCS mesh element

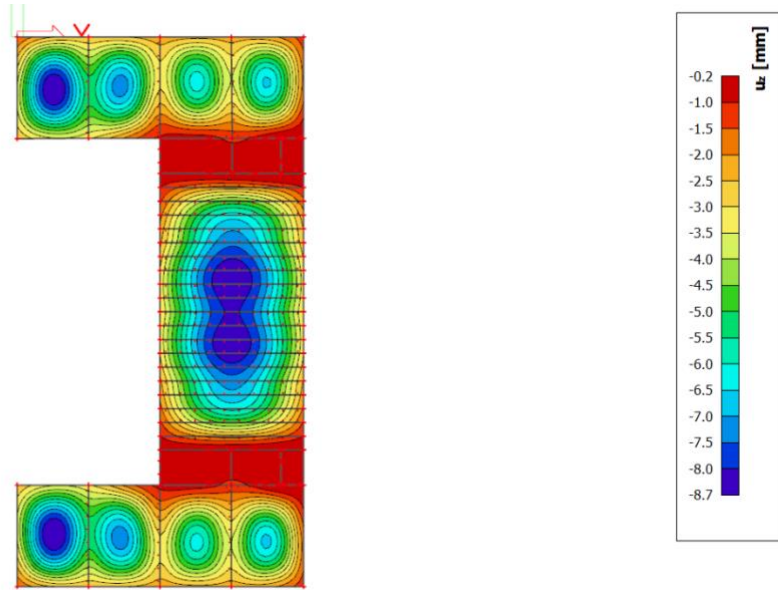

Slika 6.1.7 Progib ploče (mm) za kombinaciju GSU-2

Najveći progib iznosa je $8.7 - 0.2 = 8.5$ mm
Dozvoljen progib $L/1000 = 10000/1000 = 10$ mm
Međukatna ploča zadovoljava na progibe.

Oduzimanjem translacijske komponente pomaka dobivamo komponentu koja je se analizira odnosno provjerava dali zadovoljava dozvoljene granice.
Vidimo da je progib ploče dobiven ovim postupkom u oba modela približno jednak pa možemo zaključit da se radi o mjerodavnom progibu.
Kod 3-D modela koji su modelirani sa realnim karakteristikama tla bilo bi poželjno napraviti poseban model ploče karakteristične etaže.

6.1.2.2. Kontrola pukotina

U priložena dva dijagrama odabire se najveći moment savijanja koji će biti mjerodavan izračunu širine pukotine.

2D internal forces
Values: m_x
Linear calculation
Combination: GSU1
Extreme: Global
Selection: All
Location: In nodes avg., System: LCS
mesh element

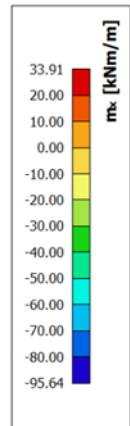

Slika 6.1.8 Moment savijanja $M_{Ed,x}$ (kNm/m) za GSU-1

2D internal forces
Values: m_y
Linear calculation
Combination: GSU1
Extreme: Global
Selection: All
Location: In nodes avg., System: LCS
mesh element

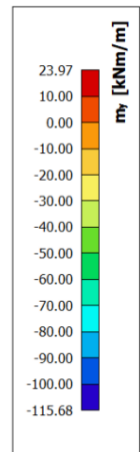
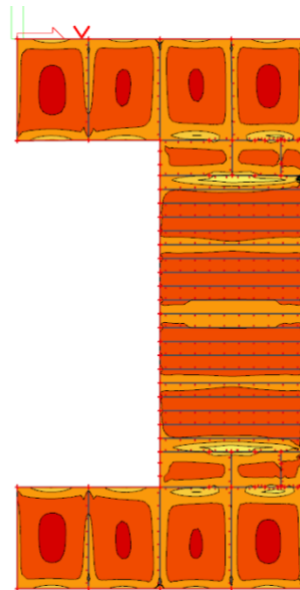

Slika 6.1.9 Moment savijanja $M_{Ed,y}$ (kNm/m) za GSU-1

Mjerodavni moment: $M = 33.91 \text{ kNm/m}$

Prognozna širina pukotine:

$$w_k = s_{r,max} \cdot (\varepsilon_{sm} - \varepsilon_{cm})$$

Vrijednost $\varepsilon_{sm} - \varepsilon_{cm}$ određuje se prema izrazu :

$$\varepsilon_{sm} - \varepsilon_{cm} = \frac{\sigma_s - k_t \cdot \frac{f_{ct,eff}}{\rho_{p,eff}} \cdot (1 + \alpha_e + \rho_{p,eff})}{E_s} \geq 0.6 \cdot \frac{\sigma_s}{E_s}$$

$$x = \frac{\alpha_{\varepsilon 1} \cdot A_{s1}}{b} \cdot \left(-1 + \sqrt{1 + \frac{2 \cdot b \cdot d}{\alpha_{\varepsilon 1} \cdot A_{s1}}} \right) = \frac{6.25 \cdot 10.11}{100} \cdot \left(-1 + \sqrt{1 + \frac{2 \cdot 100 \cdot 15}{6.25 \cdot 10.11}} \right) = 3.76 \text{ cm}$$

$$\sigma_s = \frac{M_{ed}}{z \cdot A_s} \approx \frac{M_{ed} \cdot 100}{\left(d - \frac{x}{3}\right) \cdot A_s} = \frac{3391}{\left(15 - \frac{3.76}{3}\right) \cdot 7.85} = 31.13 \text{ kN/cm}^2 = 311.3 \text{ Mpa}$$

Za C 30/37 $\rightarrow f_{ct,eff} = 2.9 \text{ MPa}$

$A_{s1} = Q - 503 = 5.03 \text{ cm}^2$

$E_{cm} = 32.0 \text{ GPa} = 32\,000 \text{ MPa}$ – modul elastičnosti betona

$E_s = 200.0 \text{ GPa} = 200\,000 \text{ MPa}$ – modul elastičnosti armature

$\alpha_e = \frac{E_s}{E_{cm}} = \frac{200}{32} = 6.25$ – Odnos modula elastičnosti

Djelotvorni koeficijent armiranja glavnom vlačnom armaturom:

$$\rho_{p,eff} = \frac{A_s}{A_{c,eff}} = \frac{10.11}{100 \cdot (2.5 \cdot 3)} = 0.0085$$

$$\varepsilon_{sm} - \varepsilon_{cm} = \frac{311.3 - 0.4 \cdot \frac{2.9}{0.0105} \cdot (1 + 6.25 \cdot 0.0105)}{200000} \geq 0.6 \cdot \frac{311.3}{200000}$$

$$0.00097 \geq 0.00093$$

$$\varepsilon_{sm} - \varepsilon_{cm} = 0.00097$$

Srednji razmak pukotina:

$$S_{r,max} = k_3 \cdot c + k_1 \cdot k_2 \cdot k_3 \cdot \frac{\emptyset}{\rho_{p,eff}} [mm]$$

$$\emptyset = 10.0 \text{ mm}$$

$c = 40 \text{ mm}$ – Zaštitni sloj uzdužne

$k_1 = 0.8$ – Rebrasta armatura

$k_2 = 0.5$ – Savijanje

$$k_3 = 3.4$$

$$k_4 = 0.425$$

$$S_{r,max} = 3.4 \cdot 40 + 0.8 \cdot 0.5 \cdot 0.425 \cdot \frac{10}{0.0105}$$

Karakteristična širina pukotina:

$$w_k = S_{r,max} \cdot (\varepsilon_{sm} - \varepsilon_{cm}) = 297.9 \cdot 0.00097 = 0.28 \text{ mm} < w_g = 0.3 \text{ mm}$$

Pukotine zadovoljavaju!

6.2. Proračun krovne ploče

Limitirajući moment:

$$M_{Rd,lim} = \mu_{Sd,lim} \cdot b_w \cdot d^2 \cdot f_{cd} = 0.159 \cdot 1.0 \cdot 0.15^2 \cdot 20 \cdot 1000 = 71.55 \text{ kNm}$$

Minimalna i maksimalna armatura:

$$A_{s,min} = 0.0015 \cdot b \cdot d = 0.0015 \cdot 100 \cdot 15 = 2.25 \text{ cm}^2 / m$$

$$A_{s,min} = 0.006 \cdot b \cdot \frac{d}{f_{yd}} = 0.06 \cdot 100 \cdot \frac{15}{500} = 1.8 \text{ cm}^2 / m$$

$$A_{s,max} = 0.31 \cdot b \cdot d \cdot \frac{f_{cd}}{f_{yd}} = 0.31 \cdot 100 \cdot 15 \cdot \frac{20}{434.80} = 21.39 \text{ cm}^2 / m$$

Za proračun armature usvaja se $\zeta \approx 0.9$, potrebna armatura :

$$A_{s1} = \frac{M_{ed}}{\zeta \cdot d \cdot f_{yd}} = \frac{M_{ed} \cdot 100}{0.9 \cdot 15 \cdot 43.5} = M_{ed} \cdot 0.17$$

Računska nosivost na poprečnu silu bez poprečne armature :

$$V_{Rd,c} = [C_{Rdc} \cdot k \cdot (100 \cdot \rho_l \cdot f_{ck})^{1/3} + k_1 \cdot \vartheta_{cp}] \cdot b_w \cdot d$$

$$k = 1.0 + \sqrt{\frac{200}{d}} = 1.0 + \sqrt{\frac{200}{150}} = 1.15 < 2.0 \rightarrow k = 2.0$$

$$k_1 = 0.15$$

$$\vartheta_{cp} = \frac{N_{ed}}{A_s} = 0.0$$

$$C_{Rdc} = \frac{0.18}{\gamma_c} = \frac{0.18}{1.5} = 0.12$$

$$\rho_l = \frac{\sum A_s}{A_c} = \frac{3.35}{15 \cdot 100} = 0.0023$$

$$V_{Rd,c} = [0.12 \cdot 2.0 \cdot (100 \cdot 0.0018 \cdot 30)^{1/3} + 0.15 \cdot 0.0] \cdot 1000 \cdot 150$$

$$V_{Rd,c} = 63.16 \text{ kN/m}$$

$$V_{Rd,c,min} = [v_{min} + k_1 \cdot \vartheta_{cp}] \cdot b_w \cdot d$$

$$k = 0.15$$

$$v_{min} = 0.035 \cdot k^{3/2} \cdot f_{ck}^{1/2} = 0.035 \cdot 2.0^{3/2} \cdot 30^{1/2} = 0.542$$

$$\vartheta_{cp} = \frac{N_{ed}}{A_c} = 0$$

$$V_{Rd,c,min} = 0.542 \cdot 1000 \cdot 150 = 81.30 \text{ kN/m}$$

6.2.1. Prikaz modela i rezultata krovne ploče

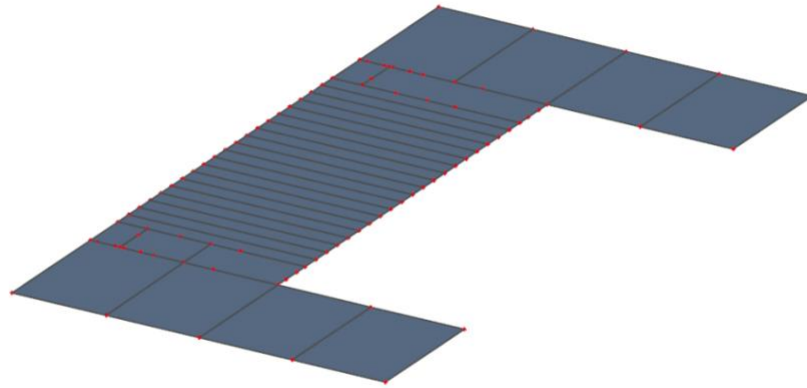

Slika 6.2.1 Prikaz modela

2D internal forces
Values: m_x
Linear calculation
Combination: GSN1
Extreme: Global
Selection: All
Location: In nodes avg., System: LCS
mesh element

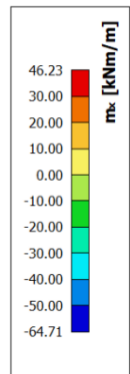
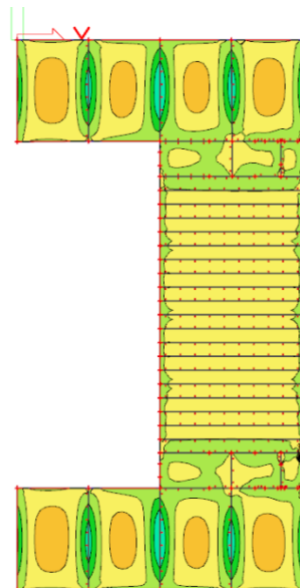

Slika 6.2.2 Moment savijanja $M_{Ed,x}$ (kNm/m) za GSN-1

2D internal forces
 Values: m_y
 Linear calculation
 Combination: GSN1
 Extreme: Global
 Selection: All
 Location: In nodes avg., System: LCS
 mesh element

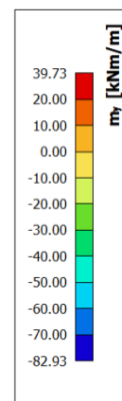
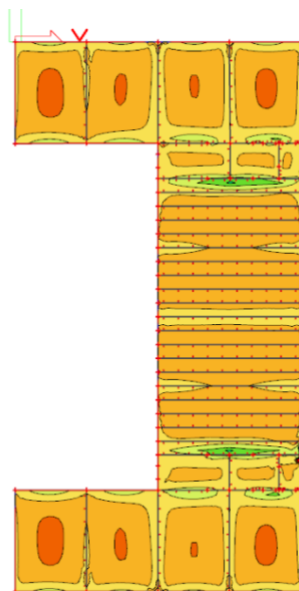

Slika 6.2.3 Moment savijanja $M_{Ed,y}$ (kNm/m) za GSN-1

2D internal forces
 Values: v_x
 Linear calculation
 Combination: GSN1
 Extreme: Global
 Selection: All
 Location: In nodes avg., System: LCS
 mesh element

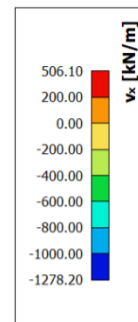
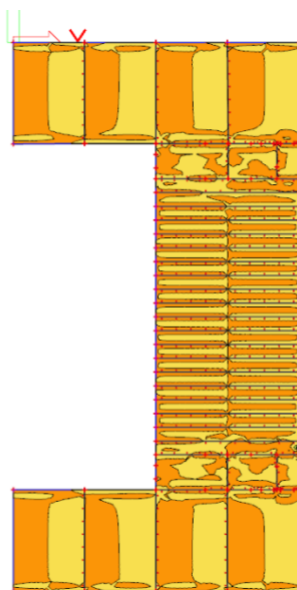

Slika 6.2.4 Poprečne sile $V_{Ed,x}$ (kN/m) za GSN-1

2D internal forces

Values: v_y
 Linear calculation
 Combination: GSN1
 Extreme: Global
 Selection: All
 Location: In nodes avg.. System: LCS
 mesh element

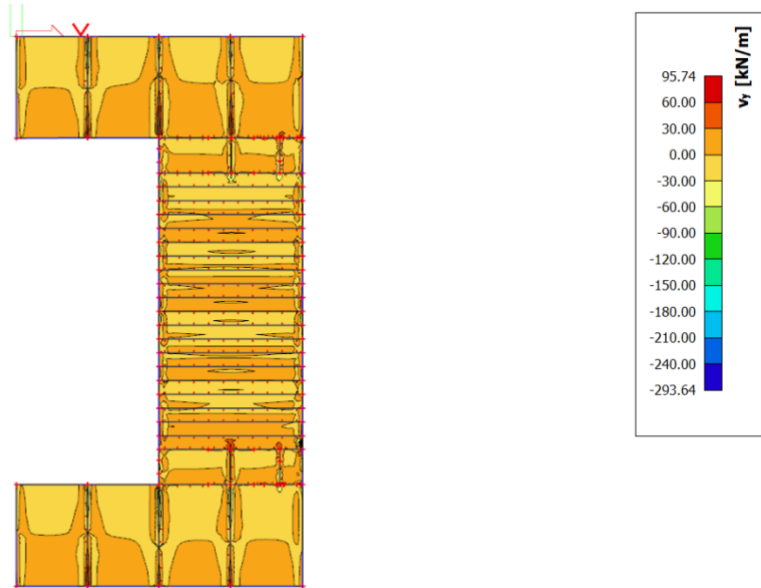

Slika 6.2.5 Poprečne sile $V_{Ed,y}$ (kN/m) za GSN

Potrebna površina armature:

Potrebna armatura u polju:

$$A_s = \frac{46.23 \cdot 100}{0,9 \cdot 15 \cdot 43.5} = 7.87 \text{ cm}^2/\text{m}'$$

Potrebna armature u ležaju:

$$A_s = \frac{64.71 \cdot 100}{0.9 \cdot 15 \cdot 43.5} = 11.01 \text{ cm}^2/\text{m}'$$

Napomena: armature u polju povećati za 20%, dok armature and ležajem smanjiti za 15%

$$7.87 \times 1.2 = 9.44 \text{ cm}^2/\text{m}'$$

$$11.01 \times 0.85 = 9.36 \text{ cm}^2/\text{m}'$$

Odabrana armature:

Polje: Q-785+2 ϕ 12 (10.11 cm^2/m')

Ležaj: R-785+2 ϕ 12 (10.11 cm^2/m')

6.2.2. Kontrola progiba krovne ploče

2D displacement

Values: u_z
Linear calculation
Combination: GSU1
Extreme: Global
Selection: All
Location: In nodes avg. on macro.
System: LCS mesh element

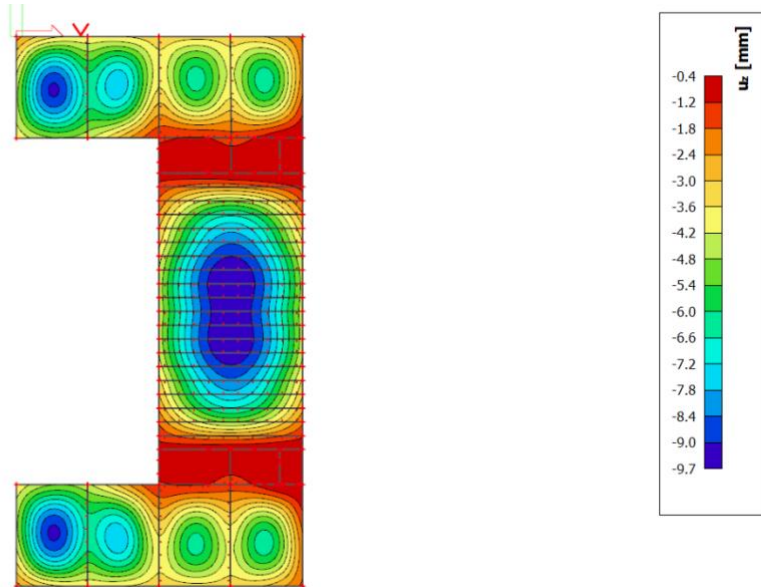

Slika 6.2.6 Progib ploče (mm) za kombinaciju GSU-1

Najveći progib iznosa je $9.7 - 0.4 = 9.3$ mm.

Dozvoljen progib $L/1000 = 10000/1000 = 10$

Krovna ploča zadovoljava na progibe.

2D displacement
Values: u_z
Linear calculation
Combination: GSU2
Extreme: Global
Selection: All
Location: In nodes avg. on macro.
System: LCS mesh element

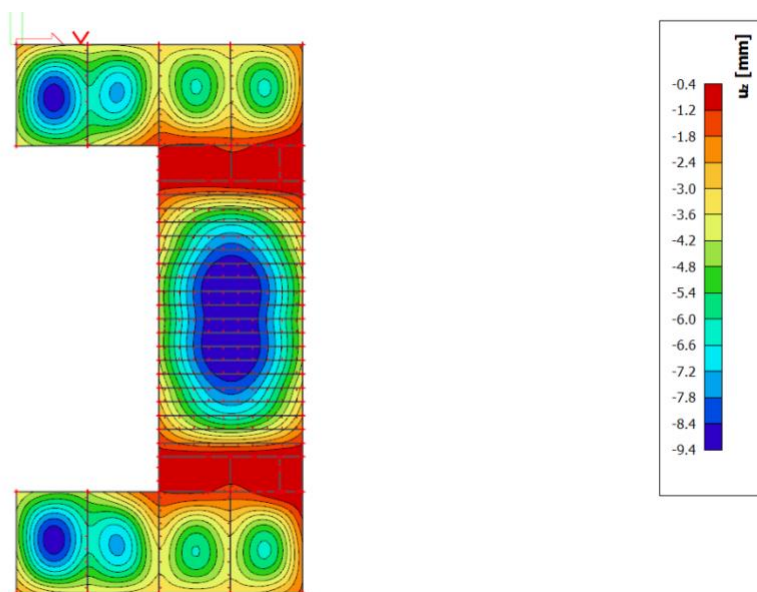

Slika 6.2.7 Progib ploče (mm) za kombinaciju GSU-2

Najveći progib iznosa je $9.4 - 0.4 = 9.0$ mm.
Dozvoljen progib $L/1000 = 10000/1000 = 10$ mm
Krovna ploča zadovoljava na progibe.

6.2.3. Kontrola pukotina krovne ploče

2D internal forces

Values: m_x
 Linear calculation
 Combination: GSU1
 Extreme: Global
 Selection: All
 Location: In nodes avg., System: LCS
 mesh element

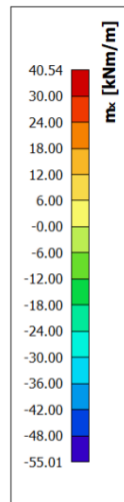
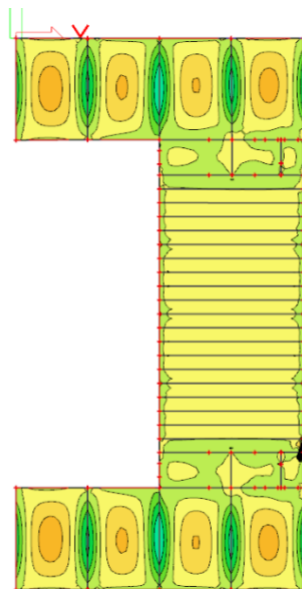

Slika 6.2.8 Moment savijanja $M_{Ed,x}$ (kNm/m) za GSU-1

2D internal forces

Values: m_y
 Linear calculation
 Combination: GSU1
 Extreme: Global
 Selection: All
 Location: In nodes avg., System: LCS
 mesh element

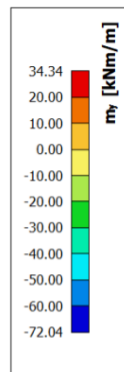
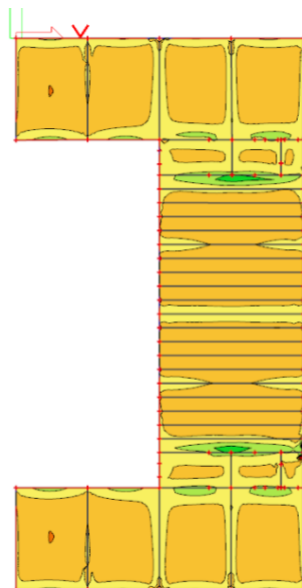

Slika 6.2.9 Moment savijanja $M_{Ed,y}$ (kNm/m) za GSU-1

Mjerodavni moment $M = 40.54 \text{ kNm/m}$

Prognozna širina pukotine:

$$w_k = s_{r,max} \cdot (\varepsilon_{sm} - \varepsilon_{cm})$$

Vrijednost $\varepsilon_{sm} - \varepsilon_{cm}$ određuje se prema izrazu :

$$\varepsilon_{sm} - \varepsilon_{cm} = \frac{\sigma_s - k_t \cdot \frac{f_{ct,eff} \cdot (1 + \alpha_e + \rho_{p,eff})}{\rho_{p,eff}}}{E_s} \geq 0.6 \cdot \frac{\sigma_s}{E_s}$$

$$x = \frac{\alpha_{\varepsilon 1} \cdot A_{s1}}{b} \cdot \left(-1 + \sqrt{1 + \frac{2 \cdot b \cdot d}{\alpha_{\varepsilon 1} \cdot A_{s1}}} \right) = \frac{6.25 \cdot 10.11}{100} \cdot \left(-1 + \sqrt{1 + \frac{2 \cdot 100 \cdot 15}{6.25 \cdot 10.11}} \right) = 3.76 \text{ cm}$$

$$\sigma_s = \frac{M_{ed}}{z \cdot A_s} \approx \frac{M_{ed} \cdot 100}{\left(d - \frac{x}{3}\right) \cdot A_s} = \frac{4054}{\left(15 - \frac{3.76}{3}\right) \cdot 10.11} = 29.11 \text{ kN/cm}^2 = 291.1 \text{ Mpa}$$

Za C 30/37 $\rightarrow f_{ct,eff} = 2.9 \text{ MPa}$

$A_{s1} = Q - 503 = 5.03 \text{ cm}^2$

$E_{cm} = 32.0 \text{ GPa} = 32\,000 \text{ MPa}$ – modul elastičnosti betona

$E_s = 200.0 \text{ GPa} = 200\,000 \text{ MPa}$ – modul elastičnosti armature

$\alpha_e = \frac{E_s}{E_{cm}} = \frac{200}{32} = 6.25$ – Odnos modula elastičnosti

Djelotvorni koeficijent armiranja glavnom vlačnom armaturom:

$$\rho_{p,eff} = \frac{A_s}{A_{c,eff}} = \frac{10.11}{100 \cdot (2.5 \cdot 3)} = 0.013$$

$$\varepsilon_{sm} - \varepsilon_{cm} = \frac{291.1 - 0.4 \cdot \frac{2.9}{0.013} \cdot (1 + 6.25 \cdot 0.013)}{200000} \geq 0.6 \cdot \frac{291.1}{200000}$$

$$0.00096 \geq 0.00087$$

$$\varepsilon_{sm} - \varepsilon_{cm} = 0.00096$$

Srednji razmak pukotina:

$$S_{r,max} = k_3 \cdot c + k_1 \cdot k_2 \cdot k_3 \cdot \frac{\emptyset}{\rho_{p,eff}} \text{ [mm]}$$

$$\emptyset = 10.0 \text{ mm}$$

c = 40 mm – Zaštitni sloj uzdužne

k₁ = 0.8 – Rebrasta armatura

k₂ = 0.5 – Savijanje

$$k_3 = 3.4$$

$$k_4 = 0.425$$

$$S_{r,max} = 3.4 \cdot 40 + 0.8 \cdot 0.5 \cdot 0.425 \cdot \frac{10}{0.0105}$$

Karakteristična širina pukotina:

$$w_k = S_{r,max} \cdot (\varepsilon_{sm} - \varepsilon_{cm}) = 297.9 \cdot 0.00096 = 0.28 \text{ mm} < w_g = 0.3 \text{ mm}$$

Pukotine zadovoljavaju!

7. PRORAČUN AB GREDA

Limitirajući moment:

$$M_{Rd,lim} = \mu_{Sd,lim} \cdot b_w \cdot d^2 \cdot f_{cd} = 0.159 \cdot 0.4 \cdot 1.17^2 \cdot 20.00 \cdot 1000 = 1741.24 \text{ kNm}$$

Minimalna i maksimalna armatura za grede:

$$\begin{aligned} A_{s,min}^{polje} &= 0.0015 \cdot b_w \cdot d = 0.0015 \cdot 40 \cdot 117 = 7.02 \text{ cm}^2 \\ A_{s,min}^{ležaj} &= 0.0015 \cdot b_{eff} \cdot d = 0.0015 \cdot 161 \cdot 117 = 28.26 \text{ cm}^2 \\ A_{s,max}^{polje} &= 0.31 \cdot b_w \cdot d \cdot \frac{f_{cd}}{f_{yd}} = 0.31 \cdot 40 \cdot 117 \cdot \frac{20.00}{434.80} = 66.73 \text{ cm}^2 \\ A_{s,max}^{ležaj} &= 0.85 \cdot b_{eff} \cdot h_f \cdot \frac{f_{cd}}{f_{yd}} = 0.85 \cdot 161 \cdot 120 \cdot \frac{20.00}{434.80} = 755.38 \text{ cm}^2 \end{aligned}$$

7.1. Međukatna greda

7.1.1. Prikaz rezultata proračuna

1D internal forces
Values: M_y
Linear calculation
Combination: GSN1
Coordinate system: Principal
Extreme 1D: Global
Selection: All

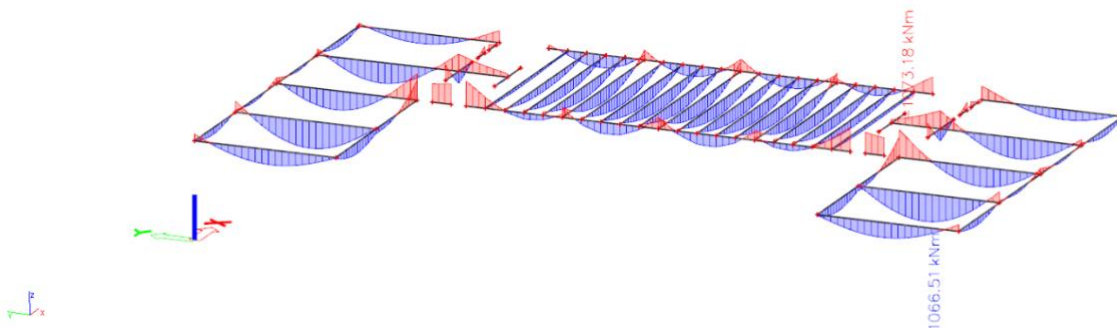

Slika 7.1.1 Moment savijanja $M_{Ed,y}$ (kNm/m) za GSN

Napomena: Predraspodjela momenta savijanja u gredama, moment u polju povećati za 30%, a moment nad ležajem smanjiti za 15%.

$$M_{max}^{polje} = 1065.51 \cdot 1.30 = 1385.16 \text{ kNm}$$

$$M_{max}^{ležaj} = 1073.18 \cdot 0.85 = 912.20 \text{ kNm}$$

1D internal forces

Values: Vz
 Linear calculation
 Combination: GSN1
 Coordinate system: Principal
 Extreme 1D: Global
 Selection: All

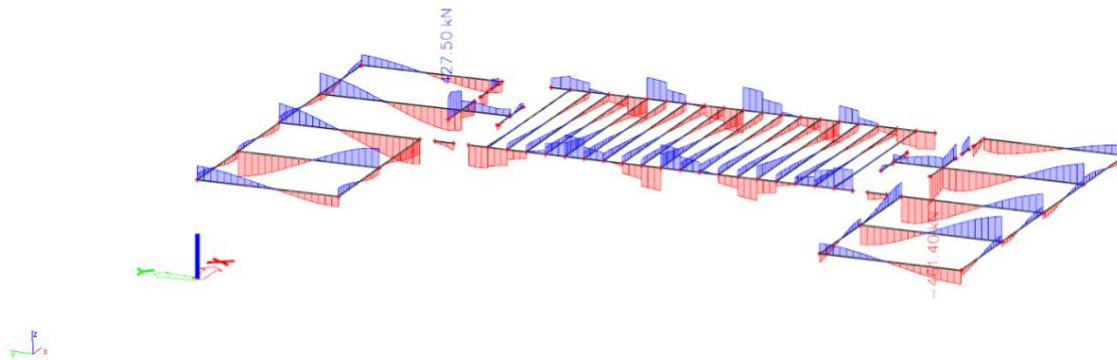

Slika 7.1.2 Poprečne sile $V_{Ed,z}$ (kN/m) za GSN

7.1.2. Dimenzioniranje na moment savijanja

Polje:

Utjecajna širina: $b_{eff} = b_0 + \frac{l_0}{5} \leq e \rightarrow b_{eff} = 40 + \frac{0.85 \cdot 710}{5} = 160.7 \text{ cm} \approx 161 \text{ cm}$

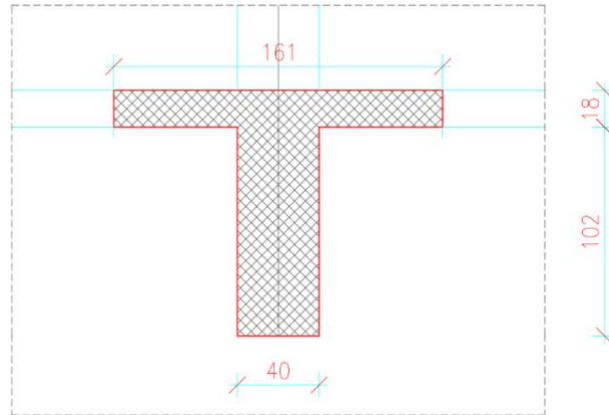

Slika 7.1.3. Poprečni presjek grede

$$M_{ed} = 1385.16 \text{ kNm}$$

$$\mu_{sd} = \frac{M_{ed}}{b_{eff} \cdot d \cdot f_{cd}} = \frac{1385.16 \cdot 100}{161 \cdot 117^2 \cdot 2.0} = 0.0314$$

Očitano: $\varepsilon_{s1} = 10.0\%$ $\varepsilon_{c2} = 1.0$ $\xi = 0.091$ $\zeta = 0.968$

$$x = \xi \cdot d = 0.091 \cdot 117 = 10.64 \text{ cm} < h_{pl}$$

$$A_{s1} = \frac{M_{ed}}{\zeta \cdot d \cdot f_{yd}} = \frac{1385.16 \cdot 100}{0.968 \cdot 117 \cdot 43.48} = 28.12 \text{ cm}^2$$

Odabrano: 6 ϕ 25 ($A_s = 29.45 \text{ cm}^2$)

Ležaj:

$$M_{ed} = 912.20 \text{ kNm}$$

$$\mu_{sd} = \frac{M_{ed}}{b_{eff} \cdot d \cdot f_{cd}} = \frac{912.20 \cdot 100}{161 \cdot 117^2 \cdot 2.0} = 0.02$$

Očitano: $\varepsilon_{s1} = 10.0\%$ $\varepsilon_{c2} = 0.08$ $\xi = 0.074$ $\zeta = 0.974$

$$x = \xi \cdot d = 0.074 \cdot 117 = 8.66 \text{ cm} < h_{pl}$$

$$A_{s1} = \frac{M_{ed}}{\zeta \cdot d \cdot f_{yd}} = \frac{912.20 \cdot 100}{0.974 \cdot 117 \cdot 43.48} = 18.41 \text{ cm}^2$$

Odabrano: 6φ20 ($A_s = 18.85 \text{ cm}^2$)

7.1.3. Dimenzioniranje na poprečnu silu

$$V_{Ed} = 427.50 \text{ kN}$$

$$V_{Rd,c} = [C_{Rdc} \cdot k \cdot (100 \cdot \rho_l \cdot f_{ck})^{1/3} + k_1 \cdot \vartheta_{cp}] \cdot b_w \cdot d$$

$$k = 1.0 + \sqrt{\frac{200}{d}} = 1.0 + \sqrt{\frac{200}{1170}} = 1.41 < 2.0 \rightarrow k = 1.41$$

$$k_1 = 0.15$$

$$\vartheta_{cp} = \frac{N_{ed}}{A_s} = 0.0$$

$$C_{Rdc} = \frac{0.18}{\gamma_c} = \frac{0.18}{1.5} = 0.12$$

$$\rho_l = \frac{\sum A_s}{A_c} = \frac{20.61}{40 \cdot 117} = 0.0044$$

$$V_{Rd,c} = [0.12 \cdot 1.41 \cdot (100 \cdot 0.0044 \cdot 30)^{1/3} + 0.15 \cdot 0.0] \cdot 400 \cdot 1170$$

$$V_{Rd,c} = 187.14 \text{ kN/m}$$

$V_{Rd,c}$ mora biti veći od:

$$V_{Rd,c,min} = [v_{min} + k_1 \cdot \vartheta_{cp}] \cdot b_w \cdot d$$

$$k = 0.15$$

$$v_{min} = 0.035 \cdot k^{3/2} \cdot f_{ck}^{1/2} = 0.035 \cdot 1.41^{3/2} \cdot 30^{1/2} = 0.32$$

$$\vartheta_{cp} = \frac{N_{ed}}{A_c} = 0$$

$$V_{Rd,c,min} = 0.32 \cdot 400 \cdot 1170 = 149.76 \text{ kN/m}$$

Uvjet je zadovoljen.

$$V_{Ed,max} = V_{Ed} = 427.50 \text{ kN}$$

$$V_{Rd,max} = 0.5 \cdot v \cdot b_w \cdot d \cdot f_{cd}$$

$$v = 0.6 \left[1.0 - \frac{f_{ck}}{250} \right] = 0.6 \left[1.0 - \frac{30}{250} \right] = 0.528$$

$$V_{Rd,max} = 0.5 \cdot 0.528 \cdot 400 \cdot 1170 \cdot 20.0 = 2471.04 > V_{Ed,max} = V_{Ed}$$

$$\frac{V_{Ed,max}}{V_{Rd,max}} = \frac{427.50}{2471.04} \approx 0.17 \rightarrow V_{Ed} = 0.17 V_{Rd,max}$$

$$s_{max} = \min\{0.75d ; 30,0 \text{ cm}\}$$

$$\min\{0.75 \cdot 117 = 87.75 ; 30,0 \text{ cm}\} \rightarrow s_{max} = 30.0 \text{ cm}$$

$$\rho_{min} = 0.0010$$

Potrebna računaska armatura.

$$A_{sw,min} = \frac{\rho_{min} \cdot s_w \cdot b_w}{m} = \frac{0.0010 \cdot 30.0 \cdot 40}{2} = 0.6 \text{ cm}^2$$

Odabrane minimalne spona: $\phi 10/30$ ($A_{sw} = 0.79 \text{ cm}^2$)

$$f_{ywd} = \frac{f_{yk}}{\gamma_s}; B 500B \rightarrow f_{ywd} = \frac{500}{1.15} = 434.8 \text{ MPa} = 43.48 \text{ kN/cm}^2$$

$$V_{Rd} = V_{Rd,s} = \frac{A_{sw}}{s} \cdot z \cdot f_{ywd} \cdot m \cdot ctg\theta$$

$$V_{Rd,s} = \frac{0.79}{30} \cdot (0.9 \cdot 117) \cdot 43.48 \cdot 2 = 241.13 \text{ kN}$$

$$V_{Ed} > V_{Rd}$$

Na mjestu maksimalne poprečne sile:

$$s_w \leq \frac{m \cdot A_{sw} \cdot f_{ywd} \cdot z}{V_{Ed}} = \frac{2 \cdot 0.79 \cdot 43.48 \cdot (0.9 \cdot 117)}{427.5} = 16.92 \text{ cm}$$

Postaviti spona: $\phi 10/10$ ($A_{sw} = 0.79 \text{ cm}^2$)

7.1.4. Kontrola progiba

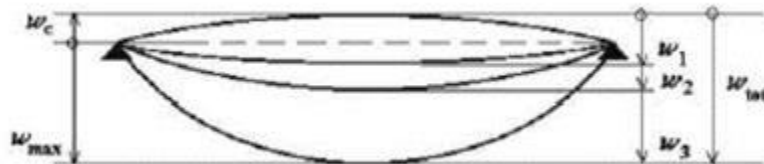

w_c – nadvišenje neopterećenog konstruktivnog elementa

w_1 – početni progib od stalnog opterećenja

w_2 – dugotrajni progib od stalnog opterećenja

w_3 – progib od promjenjivog opterećenja

w_{max} – ukupni progib

Konstrukcija	w_{max}	$w_2 + w_3$
Krovišta	L/200	L/250
Prohodna krovišta	L/250	L/300
Stropovi	L/250	L/300
Stropovi/krovovi sa žbukom ili drugim krhkim završnim slojevima ili nesavitljivim pregradama	L/300	L/350
Stropovi koje podupiru stupovi (osim ako je progib uzet u sklopu proračuna za granično stanje nosivosti)	L/400	L/500
Kada w_{max} može narušiti izgled zgrade	L/250	-

Tablica X.XX Ograničenje vertikalnih progiba za karakterističnu kombinaciju

1D deformations

Values: u_z
Linear calculation
Combination: GSU1
Coordinate system: Global
Extreme 1D: Global
Selection: All

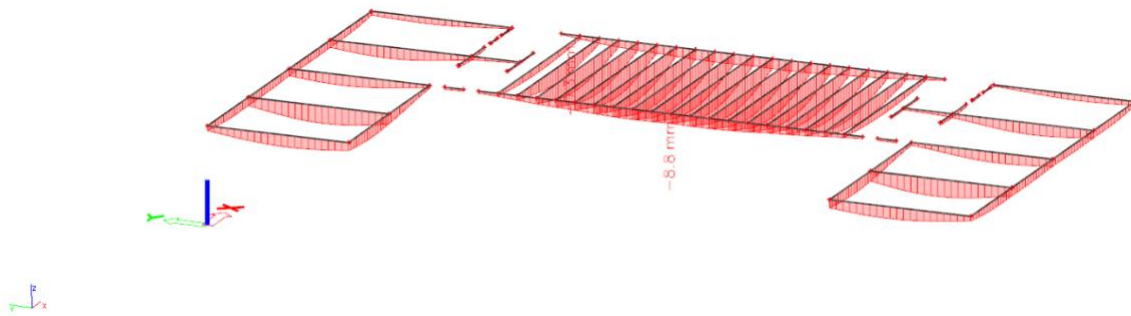

Najveći progib iznosa je $8.8 - (4+12)/2 = 0.8$ mm.

Dozvoljen progib $L/1000 = 710/1000 = 7.1$ mm.

Međukatna greda zadovoljava na progibe.

7.1.5 Kontrola pukotina

1D internal forces

Values: M_y
 Linear calculation
 Combination: GSU1
 Coordinate system: Principal
 Extreme 1D: Global
 Selection: All

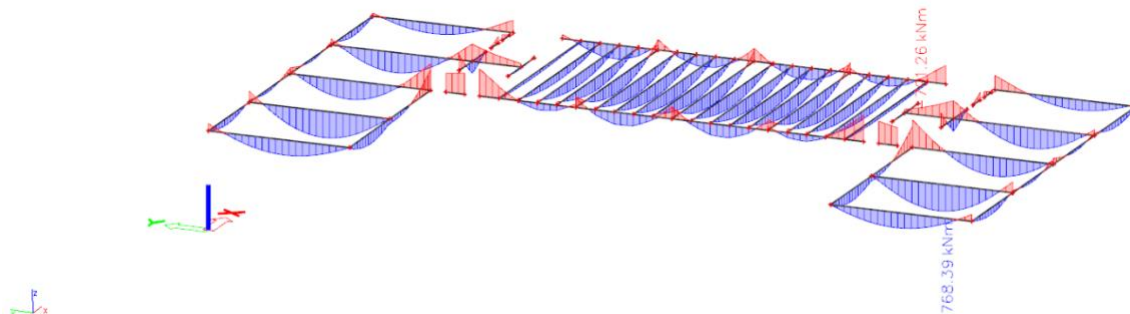

Slika 7. 1. 6 Moment savijanja $M_{Ed,y}$ (kNm/m) za GSU-1

Mjerodavni moment $M = 768.39 \text{ kNm/m}$

Prognozna širina pukotine:

$$w_k = s_{r,max} \cdot (\varepsilon_{sm} - \varepsilon_{cm})$$

Vrijednost $\varepsilon_{sm} - \varepsilon_{cm}$ određuje se prema izrazu :

$$\varepsilon_{sm} - \varepsilon_{cm} = \frac{\sigma_s - k_t \frac{f_{ct,eff}}{\rho_{p,eff}} \cdot (1 + \alpha_e + \rho_{p,eff})}{E_s} \geq 0.6 \cdot \frac{\sigma_s}{E_s}$$

$$x = \frac{\alpha_{\varepsilon 1} \cdot A_{s1}}{b} \cdot \left(-1 + \sqrt{1 + \frac{2 \cdot b \cdot d}{\alpha_{\varepsilon 1} \cdot A_{s1}}} \right) = \frac{6.25 \cdot 29.45}{100} \cdot \left(-1 + \sqrt{1 + \frac{2 \cdot 40 \cdot 117}{6.25 \cdot 29.45}} \right) = 2.76 \text{ cm}$$

$$\sigma_s = \frac{M_{ed}}{z \cdot A_s} \approx \frac{M_{ed} \cdot 100}{\left(d - \frac{x}{3}\right) \cdot A_s} = \frac{76839}{\left(117 - \frac{2.76}{3}\right) \cdot 29.45} = 22.47 \text{ kN/cm}^2 = 224.7 \text{ Mpa}$$

Za C 30/37 $\rightarrow f_{ct,eff} = 2.9 \text{ MPa}$

$$A_{s1} = 6\phi 25 = 29.45 \text{ cm}^2$$

$E_{cm} = 32.0 \text{ GPa} = 32\,000 \text{ MPa}$ – modul elastičnosti betona

$E_s = 200.0 \text{ GPa} = 200\,000 \text{ MPa}$ – modul elastičnosti armature

$$\alpha_e = \frac{E_s}{E_{cm}} = \frac{200}{32} = 6.25 \text{ – Odnos modula elastičnosti}$$

Djelotvorni koeficijent armiranja glavnom vlačnom armaturom:

$$\rho_{p,eff} = \frac{A_s}{A_{c,eff}} = \frac{29.45}{100 \cdot (2.5 \cdot 3)} = 0.039$$

$$\varepsilon_{sm} - \varepsilon_{cm} = \frac{224.7 - 0.4 \cdot \frac{2.9}{0.039} \cdot (1 + 29.45 \cdot 0.039)}{200000} \geq 0.6 \cdot \frac{224.7}{200000}$$

$$0.00081 \geq 0.00067$$

$$\varepsilon_{sm} - \varepsilon_{cm} = 0.00081$$

Srednji razmak pukotina:

$$S_{r,max} = k_3 \cdot c + k_1 \cdot k_2 \cdot k_3 \cdot \frac{\phi}{\rho_{p,eff}} \text{ [mm]}$$

$$\phi = 25.0 \text{ mm}$$

$c = 40 \text{ mm}$ – Zaštitni sloj uzdužne

$k_1 = 0.8$ – Rebrasta armatura

$k_2 = 0.5$ – Savijanje

$$k_3 = 3.4$$

$$k_4 = 0.425$$

$$S_{r,max} = 3.4 \cdot 40 + 0.8 \cdot 0.5 \cdot 0.425 \cdot \frac{20}{0.039} = 223.17 \text{ mm}$$

Karakteristična širina pukotina:

$$w_k = S_{r,max} \cdot (\varepsilon_{sm} - \varepsilon_{cm}) = 223.17 \cdot 0.00081 = 0.18 \text{ mm} < w_g = 0.3 \text{ mm}$$

Pukotine zadovoljavaju!

7.2. Krovna greda

7.2.1. Prikaz rezultata proračuna

1D internal forces

Values: M_y
Linear calculation
Combination: GSN1
Coordinate system: Principal
Extreme 1D: Global
Selection: All

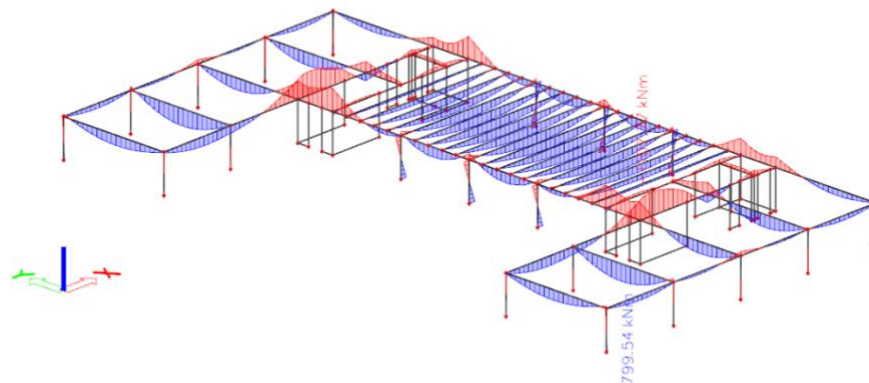

Slika 7.2.1 Moment savijanja $M_{Ed,y}$ (kNm/m) za GSN

$$M_{max}^{polje} = 799.54 \cdot 1.30 = 1039.40 \text{ kNm}$$

$$M_{max}^{ležaj} = 1107.77 \cdot 0.85 = 941.60 \text{ kNm}$$

1D internal forces

Values: V_z
Linear calculation
Combination: GSN1
Coordinate system: Principal
Extreme 1D: Global
Selection: All

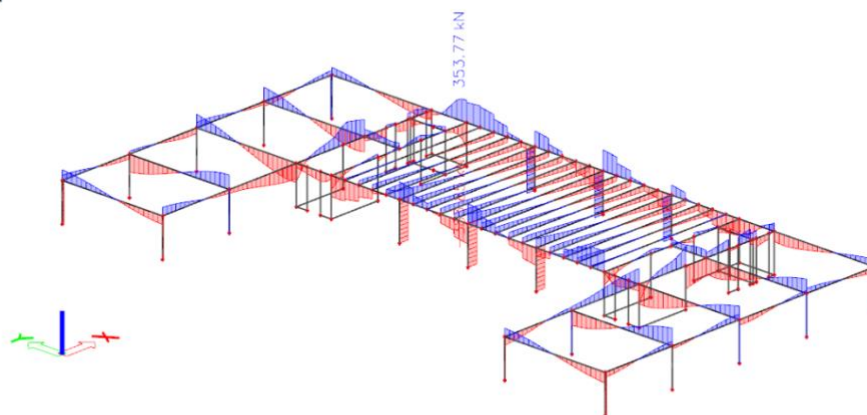

Slika 7.2.2 Poprečne sile $V_{Ed,z}$ (kN/m) za GSN

7.2.2. Dimenzioniranje na moment savijanja

Polje:

Utjecajna širina: $b_{eff} = b_0 + \frac{l_0}{5} \leq e \rightarrow b_{eff} = 40 + \frac{0.85 \cdot 710}{5} = 160.7 \text{ cm} \approx 161 \text{ cm}$

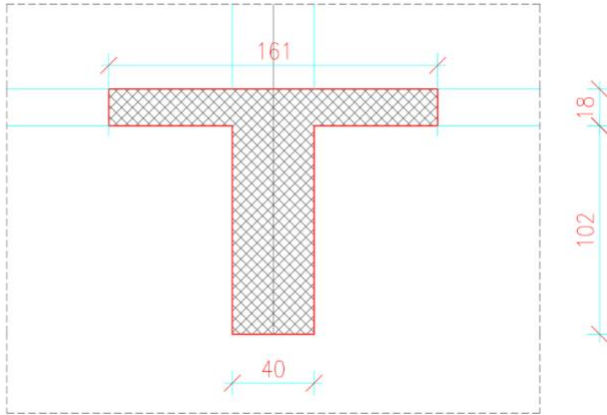

Slika 7.1.3. Poprečni presjek grede

$$M_{ed} = 1039.40 \text{ kNm}$$

$$\mu_{sd} = \frac{M_{ed}}{b_{eff} \cdot d \cdot f_{cd}} = \frac{1039.40 \cdot 100}{161 \cdot 117^2 \cdot 2.0} = 0.0235$$

Očitano: $\varepsilon_{s1} = 10.0\%$ $\varepsilon_{c2} = 0.9$ $\xi = 0.083$ $\zeta = 0.971$

$$x = \xi \cdot d = 0.083 \cdot 117 = 9.71 \text{ cm} < h_{pl}$$

$$A_{s1} = \frac{M_{ed}}{\zeta \cdot d \cdot f_{yd}} = \frac{1039.40 \cdot 100}{0.971 \cdot 117 \cdot 43.48} = 21.04 \text{ cm}^2$$

Odabrano: $6\phi 22$ ($A_s = 22.81 \text{ cm}^2$)

Ležaj:

$$M_{ed} = 941.60 \text{ kNm}$$

$$\mu_{sd} = \frac{M_{ed}}{b_{eff} \cdot d \cdot f_{cd}} = \frac{941.60 \cdot 100}{161 \cdot 117^2 \cdot 2.0} = 0.021$$

Očitano: $\varepsilon_{s1} = 10.0\%$ $\varepsilon_{c2} = 0.08$ $\xi = 0.074$ $\zeta = 0.974$

$$x = \xi \cdot d = 0.074 \cdot 117 = 8.66 \text{ cm} < h_{pl}$$

$$A_{s1} = \frac{M_{ed}}{\zeta \cdot d \cdot f_{yd}} = \frac{941.60 \cdot 100}{0.974 \cdot 117 \cdot 43.48} = 19.00 \text{ cm}^2$$

Odabrano: $5\phi 22$ ($A_s = 19.01 \text{ cm}^2$)

7.2.3. Dimenzioniranje na poprečnu silu

$$V_{Ed} = 383.85 \text{ kN}$$

$$V_{Rd,c} = [C_{Rdc} \cdot k \cdot (100 \cdot \rho_l \cdot f_{ck})^{1/3} + k_1 \cdot \vartheta_{cp}] \cdot b_w \cdot d$$

$$k = 1.0 + \sqrt{\frac{200}{d}} = 1.0 + \sqrt{\frac{200}{1170}} = 1.41 < 2.0 \rightarrow k = 1.41$$

$$k_1 = 0.15$$

$$\vartheta_{cp} = \frac{N_{ed}}{A_s} = 0.0$$

$$C_{Rdc} = \frac{0.18}{\gamma_c} = \frac{0.18}{1.5} = 0.12$$

$$\rho_l = \frac{\sum A_s}{A_c} = \frac{22.81}{40 \cdot 117} = 0.0049$$

$$V_{Rd,c} = [0.12 \cdot 1.41 \cdot (100 \cdot 0.0049 \cdot 30)^{1/3} + 0.15 \cdot 0.0] \cdot 400 \cdot 1170$$

$$V_{Rd,c} = 193.97 \text{ kN/m}$$

$V_{Rd,c}$ mora biti veći od:

$$V_{Rd,c,min} = [v_{min} + k_1 \cdot \vartheta_{cp}] \cdot b_w \cdot d$$

$$k = 0.15$$

$$v_{min} = 0.035 \cdot k^{3/2} \cdot f_{ck}^{1/2} = 0.035 \cdot 1.41^{3/2} \cdot 30^{1/2} = 0.32$$

$$\vartheta_{cp} = \frac{N_{ed}}{A_c} = 0$$

$$V_{Rd,c,min} = 0.32 \cdot 400 \cdot 1170 = 149.76 \text{ kN/m}$$

Uvjet je zadovoljen.

$$V_{Ed,max} = V_{Ed} = 383.85 \text{ kN}$$

$$V_{Rd,max} = 0.5 \cdot v \cdot b_w \cdot d \cdot f_{cd}$$

$$v = 0.6 \left[1.0 - \frac{f_{ck}}{250} \right] = 0.6 \left[1.0 - \frac{30}{250} \right] = 0.528$$

$$V_{Rd,max} = 0.5 \cdot 0.528 \cdot 400 \cdot 1170 \cdot 20.0 = 2471.04 > V_{Ed,max} = V_{Ed}$$

$$\frac{V_{Ed,max}}{V_{Rd,max}} = \frac{383.85}{2471.04} \approx 0.15 \rightarrow V_{Ed} = 0.175$$

$$s_{max} = \min\{0.75d ; 30,0 \text{ cm}\}$$

$$\min\{0.75 \cdot 117 = 87.75 ; 30,0 \text{ cm}\} \rightarrow s_{max} = 30.0 \text{ cm}$$

$$\rho_{min} = 0.0010$$

Potrebna računaska armatura.

$$A_{sw,min} = \frac{\rho_{min} \cdot s_w \cdot b_w}{m} = \frac{0.0010 \cdot 30.0 \cdot 40}{2} = 0.6 \text{ cm}^2$$

Odabrane minimalne spone: $\phi 10/30$ ($A_{sw} = 0.79 \text{ cm}^2$)

$$f_{ywd} = \frac{f_{yk}}{\gamma_s}; B 500B \rightarrow f_{ywd} = \frac{500}{1.15} = 434.8 \text{ MPa} = 43.48 \text{ kN/cm}^2$$

$$V_{Rd} = V_{Rd,s} = \frac{A_{sw}}{s} \cdot z \cdot f_{ywd} \cdot m \cdot ctg\theta$$

$$V_{Rd,s} = \frac{0.79}{30} \cdot (0.9 \cdot 117) \cdot 43.48 \cdot 2 = 241.13 \text{ kN}$$

$$V_{Ed} > V_{Rd}$$

Na mjestu maksimalne poprečne sile:

$$S_w \leq \frac{m \cdot A_{sw} \cdot f_{ywd} \cdot z}{V_{Ed}} = \frac{2 \cdot 0.79 \cdot 43.48 \cdot (0.9 \cdot 117)}{383.85} = 18.85 \text{ cm}$$

Postaviti spone: $\phi 10/10$ ($A_{sw} = 0.79 \text{ cm}^2$)

7.2.4 Kontrola progiba

1D deformations

Values: Uz
Linear calculation
Combination: GSU1
Coordinate system: Global
Extreme 1D: Global
Selection: All

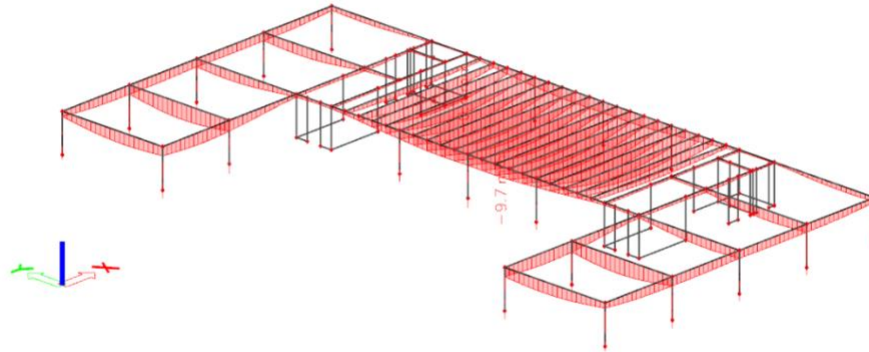

Slika 7.2.4 Progib grede (mm) za kombinaciju GSU-1

Najveći progib iznosa je $9.4 - (4+12)/2 = 1.4$ mm.

Dozvoljen progib $L/1000 = 710/1000 = 7.1$ mm.

Međukatna greda zadovoljava na progibe.

7.2.5. Kontrola pukotina

1D internal forces

Values: M_y
 Linear calculation
 Combination: GSN1
 Coordinate system: Principal
 Extreme 1D: Global
 Selection: All

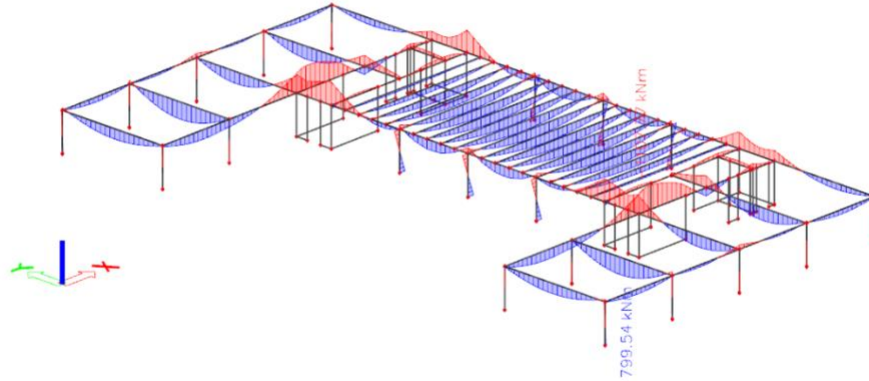

Slika 7.2.5 Moment savijanja $M_{Ed,y}$ (kNm) za GSU-1

Mjerodavni moment: $M = 799.54 \text{ kNm/m}$

Prognozna širina pukotine:

$$w_k = s_{r,max} \cdot (\varepsilon_{sm} - \varepsilon_{cm})$$

Vrijednost $\varepsilon_{sm} - \varepsilon_{cm}$ određuje se prema izrazu :

$$\varepsilon_{sm} - \varepsilon_{cm} = \frac{\sigma_s - k_t \frac{f_{ct,eff}}{\rho_{p,eff}} \cdot (1 + \alpha_\varepsilon + \rho_{p,eff})}{E_s} \geq 0.6 \cdot \frac{\sigma_s}{E_s}$$

$$x = \frac{\alpha_{\varepsilon 1} \cdot A_{s1}}{b} \cdot \left(-1 + \sqrt{1 + \frac{2 \cdot b \cdot d}{\alpha_{\varepsilon 1} \cdot A_{s1}}} \right) = \frac{6.25 \cdot 22.81}{100} \cdot \left(-1 + \sqrt{1 + \frac{2 \cdot 40 \cdot 117}{6.25 \cdot 22.81}} \right) = 10.21 \text{ cm}$$

$$\sigma_s = \frac{M_{ed}}{z \cdot A_s} \approx \frac{M_{ed} \cdot 100}{\left(d - \frac{x}{3}\right) \cdot A_s} = \frac{79954}{\left(117 - \frac{10.21}{3}\right) \cdot 22.81} = 30.86 \text{ kN/cm}^2 = 308.6 \text{ Mpa}$$

Za C 30/37 $\rightarrow f_{ct,eff} = 2.9 \text{ MPa}$

$$A_{s1} = 6\phi 22 = 22.81 \text{ cm}^2$$

$E_{cm} = 32.0 \text{ GPa} = 32\,000 \text{ MPa}$ – modul elastičnosti betona

$E_s = 200.0 \text{ GPa} = 200\,000 \text{ MPa}$ – modul elastičnosti armature

$$\alpha_e = \frac{E_s}{E_{cm}} = \frac{200}{32} = 6.25 \text{ – Odnos modula elastičnosti}$$

Djelotvorni koeficijent armiranja glavnom vlačnom armaturom:

$$\rho_{p,eff} = \frac{A_s}{A_{c,eff}} = \frac{22.81}{100 \cdot (2.5 \cdot 3)} = 0.03$$

$$\varepsilon_{sm} - \varepsilon_{cm} = \frac{308.6 - 0.4 \cdot \frac{2.9}{0.03} \cdot (1 + 22.81 \cdot 0.03)}{200000} \geq 0.6 \cdot \frac{308.6}{200000}$$

$$0.0012 \geq 0.00092$$

$$\varepsilon_{sm} - \varepsilon_{cm} = 0.0012$$

Srednji razmak pukotina:

$$s_{r,max} = k_3 \cdot c + k_1 \cdot k_2 \cdot k_3 \cdot \frac{\phi}{\rho_{p,eff}} \text{ [mm]}$$

$$\phi = 22.0 \text{ mm}$$

$c = 40 \text{ mm}$ – Zaštitni sloj uzdužne

$k_1 = 0.8$ – Rebrasta armatura

$k_2 = 0.5$ – Savijanje

$$k_3 = 3.4$$

$$k_4 = 0.425$$

$$s_{r,max} = 3.4 \cdot 40 + 0.8 \cdot 0.5 \cdot 0.425 \cdot \frac{22}{0.03} = 138.26 \text{ mm}$$

Karakteristična širina pukotina:

$$w_k = s_{r,max} \cdot (\varepsilon_{sm} - \varepsilon_{cm}) = 138.26 \cdot 0.0012 = 0.16 \text{ mm} < w_g = 0.3 \text{ mm}$$

Pukotine zadovoljavaju!

8. PRORAČUN ZIDOVA

- Minimalna debljina: $b_{wo} \geq \max \{0.15 \text{ m}, h_s/20\}$, (h_s =svijetla katna visina) ▪
Ograničenje naprezanja u betonu (srednjeg tlačnog naprezanja) je:

$$v_d = N_{Ed}/A_c f_{cd} \leq 0.40 \text{ (klasa DCM), odnosno } \sigma_{c,Rd} \leq 0.40 * f_{cd}$$

N_{Ed} = uzdužna sila u proračunu potresne proračunske situacije ▪

Kritično područje:

$\min \{2L_w, h_s\} \geq h_{cr} \geq \max \{L_w, h_w/6\}$, (L_w =duljina zida, h_w =ukupna visina zida, h_s =svijetla katna visina)

- Minimalno armiranje:

na krajevima zida:

vertikalno: $\rho_{min} = 0.5\%$ od površine $A_c = L_c * b_w$ ($L_c = \max \{0.15 L_w, 1.5 b_w\}$) spone: min $\phi 6$; max. razmak: min $\{8d_{bL}, b_o/2, 175 \text{ mm}\}$ (d_{bL} =promjer vert. šipki; b_o =širina jezgre)

ostali dio zida:

vertikalno: $\rho_{min} = 0.2\%$

horizontalno: $\rho_{min} = 0.2\%$

spone: min $4\phi 6/m^2$

- Lagano armirani zidovi $L_w \geq \min \{4 \text{ m}, 2/3 h_w\}$
- Najmanji omjer poprečne armature $\rho_{w,min}$ velikih slabo armiranih betonskih zidova:

$$\rho_{w,min} = 0.15 \cdot (f_{ct,m}/f_{yd}).$$

$$C 25/30 (f_{ct,m}=2.6 \text{ MPa}); B 500B (f_y=500 \text{ MPa}); \rho_{w,min} = 0.15 * (2.6/435) = 0.0009$$

$$b_w=16 \text{ cm}; A_{s,min}=0.0009*16*100/2=0.72 \text{ cm}^2$$

$$b_w=20 \text{ cm}; A_{s,min}=0.0009*20*100/2=0.90 \text{ cm}^2$$

$$b_w=30 \text{ cm}; A_{s,min}=0.0009*30*100/2=1.35 \text{ cm}^2$$

$$b_w=40 \text{ cm}; A_{s,min}=0.0009*40*100/2=1.80 \text{ cm}^2$$

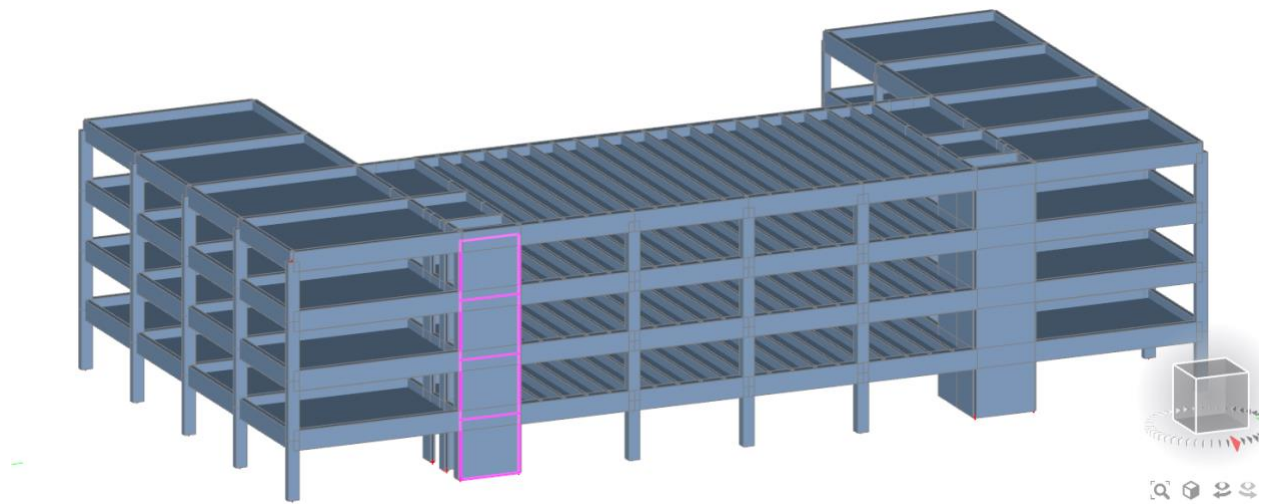

Slika 8.1 Položaj zida na kojem je izvršen proračun

2D displacement

Values: U_{total}
 Linear calculation
 Combination: GSU2
 Extreme: Global
 Selection: All
 Location: In nodes avg. on macro.
 System: LCS mesh element

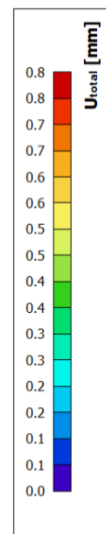
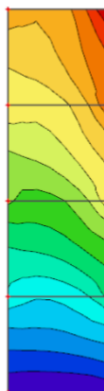

Slika 8.2 Pomaci (mm) za GSU-2

3D stress

Values: σ_y (2D)
Linear calculation
Load case: G
Selection: All
Location: In nodes avg. on macro.
System: LCS mesh element
Basic magnitudes

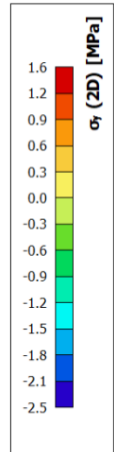
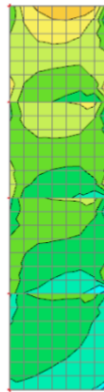

Slika 8.3 Tlačna naprezanja za GSU-2

2D internal forces

Values: n_x
Linear calculation
Combination: GSN1
Extreme: Global
Selection: All
Location: In nodes avg.. System: LCS
mesh element

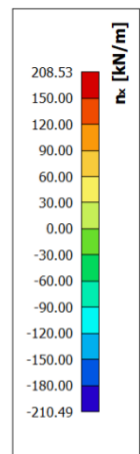
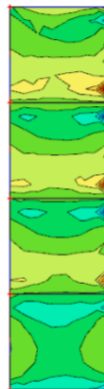

Slika 8.4 Uzdužne sile smjer x u zidovima za anvelopu GSN

2D internal forces

Values: n_y

Linear calculation

Combination: GSN1

Extreme: Global

Selection: All

Location: In nodes avg., System: LCS
mesh element

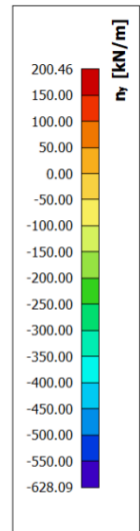
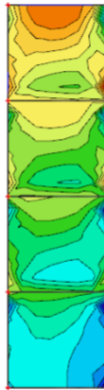

Slika 8.5 Uzdužne sile smjer Y u zidovima za anvelopu GSN

9. PRORAČUN STUPOVA

Ograničenja naprezanja u betonu

$\sigma_c \leq 0.45 f_{ck}$ za nazovistalnu kombinaciju GSU-2

GSU-2 = 1.0G + 0.3Q za C30/37

$\sigma_c \leq 0.45 \cdot 30 = 13.5 \text{ MPa}$

1D internal forces

Values: N

Linear calculation

Combination: GSU2

Coordinate system: Principal

Extreme 1D: Global

Selection: All

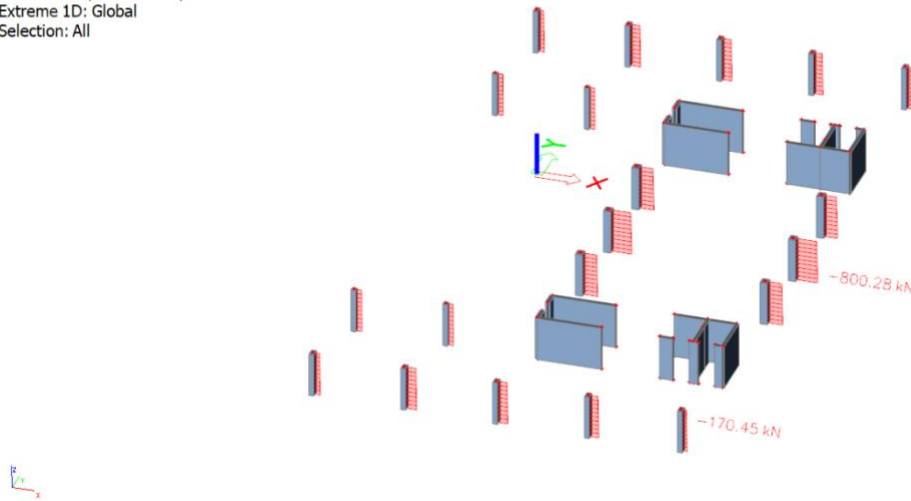

Slika 9.1 Uzdužne sile u stupovima N_{ed} (kN) za GSU-2

1D stresses

Values: σ_x

Linear calculation

Load case: G

Coordinate system: Principal

Extreme 1D: Global

Selection: All

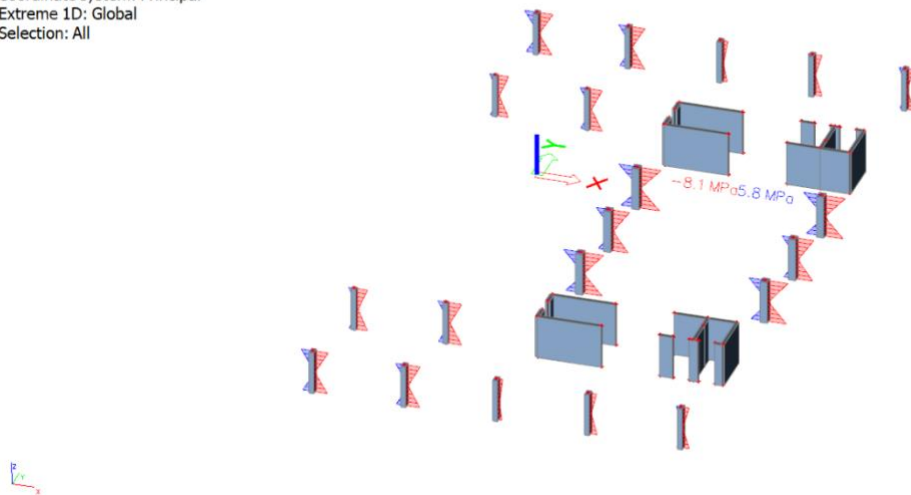

Slika 9.2 Srednje tlačno naprezanje u stupovima $\sigma_{c,Ed}$ (MPa) za GSU-2

Beton: 30/37; $f_{ck}=30$ MPa

Kontrolira se srednje tlačno naprezanje u stupu za nazovistalnu kombinaciju.

GSU-2=1.0G + 0.3Q

$\sigma_{c,Ed} \leq 0.45 f_{ck}$

Za 30/37; $0.45 * f_{ck} = 0.45 * 30 = 13.5$ MPa

U niti jednom stupu (dimenzije prema planu pozicija) nije preokračeno srednje tlačno naprezanje

Stup spada u razred duktilnosti M, stoga treba biti zadovoljen uvjet:

$N_{sd} = 800.28$

$b * h \geq N_{sd} / (0.65 * f_{cd}) \rightarrow 1600 \geq 615.38$

Poprečni presjek stupa: $b/h = 40/40$

Minimalna vertikalna armature stupa

a) $A_{s,min} = 8\phi 12$ (9.05 cm²)

b) $A_{s,min} = 0.15 * N_{sd} / f_{yd} = 0.15 * 800.28 / 43.48 = 2.76$ cm²

c) $A_{s,min} = 0.003 * A_c = 4.8$ cm²

d) $A_{s,min} = 0.01 * A_c = 16$ cm²

Odabrana vertikalna armature: $6\phi 20$ (18.85 cm²)

Minimalna poprečna armature stupa:

a) $e_w = 12\phi_{s,min} = 26.45$ cm

b) $e_w \leq b = 40$ cm

c) $e_w \leq 30$ cm

d) $e_w \leq 15$ cm

Odabrana poprečna armatura: spone $\phi 6/15$ cm

Napomena: Na područjima neosredno u blizini ležaja u dužini od 50 cm ten a preklopima armature progustiti razmak na 9 cm.

10. PRORAČUN STUBIŠTA

10.1. Mjerodavne rezne sile

GSN-1

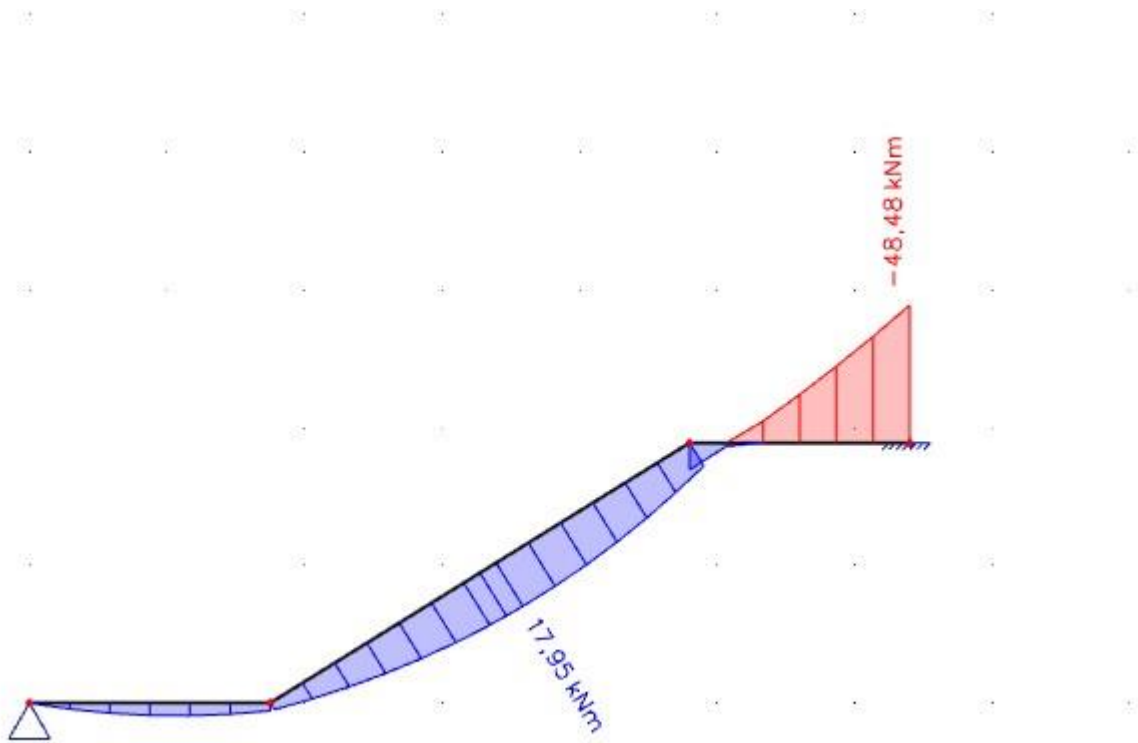

Slika 10.1 Moment savijanja na stubištu

Napomena: Dobivenu armaturu zbog predraspodjele umanjiti nad ležajem za 15% i povećati u polju 25%.

Mjerodavni moment u polju: 23.34 kNm

Mjerodavni moment na ležaju: 41.21 kNm

10.2. Dimenzioniranje stubišta

$h = 18 \text{ cm}$

zaštitni sloj: $a = 3 \text{ cm}$; $d = 15 \text{ cm}$

Beton : C 30/37

$F_{ck} = 25.0 \text{ MPa}$

$E_{cm} = 32.0 \text{ GPa}$

Armatura : B 500B

$f_{yk} = 500.0 \text{ MPa}$

Polje

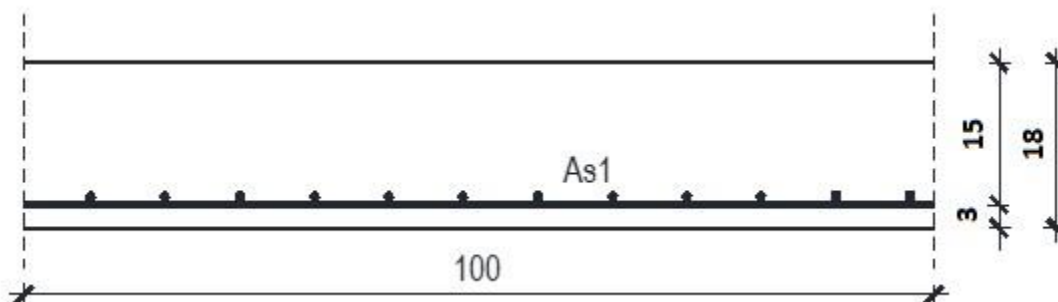

Slika 10.2. Poprečni presjek ploče stubišta

$$\mu_{sd} = \frac{M_{Ed}}{b_{eff} \cdot d^2 \cdot f_{cd}} = \frac{2334}{100 \cdot 15^2 \cdot 2.0} = 0.052$$

Očitano: $\varepsilon_{s1} = 10.0 \%$ $\varepsilon_{c2} = 1.4$ $\xi = 0.123$ $\zeta = 0.956$

$$x = \xi \cdot d = 0.123 \cdot 15 = 1.845 \text{ cm} < h_{pl}$$

$$A_{s1} = \frac{M_{Ed}}{\zeta \cdot d \cdot f_{cd}} = \frac{2334}{0.956 \cdot 15 \cdot 2.0} = 3.74 \text{ cm}^2$$

Odabrana mreža Q-385 ($A_s = 3.85 \text{ cm}^2$)

Ležaj

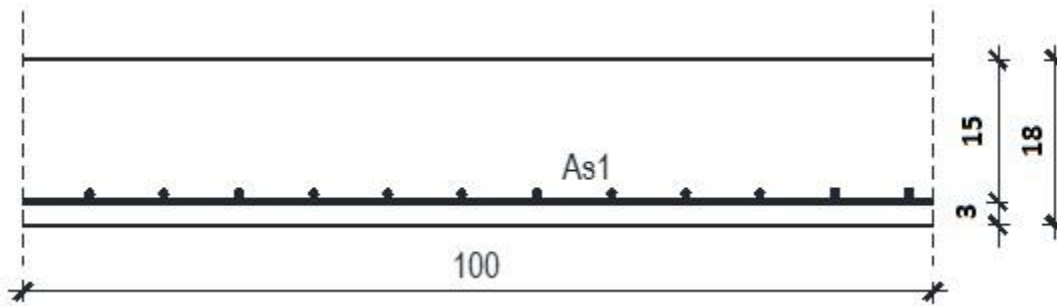

Slika 10.3. Poprečni presjek ploče stubišta

$$\mu_{sd} = \frac{M_{Ed}}{b_{eff} \cdot d^2 \cdot f_{cd}} = \frac{4121}{100 \cdot 15^2 \cdot 2.0} = 0.092$$

Očitano: $\varepsilon_{s1} = 10.0 \text{ ‰}$ $\varepsilon_{c2} = 0.6$ $\xi = 0.057$ $\zeta = 0.981$

$$x = \xi \cdot d = 0.057 \cdot 15 = 0.855 \text{ cm} < h_{pl}$$

$$A_{s1} = \frac{M_{Ed}}{\zeta \cdot d \cdot f_{cd}} = \frac{4121}{0.956 \cdot 15 \cdot 2.0} = 6.44 \text{ cm}^2$$

Odabrana mreža: R-785 ($A_s = 7.85 \text{ cm}^2$)

11. PRORAČUN TEMELJA SAMCA ISPOD STUPA

11.1 Dimenzioniranje temeljnih stopa

Za dobivanje mjerodavnih napreznaja koristili smo kombinaciju $G_{SN-1}=1.35G+1.35G_1+1.5Q$

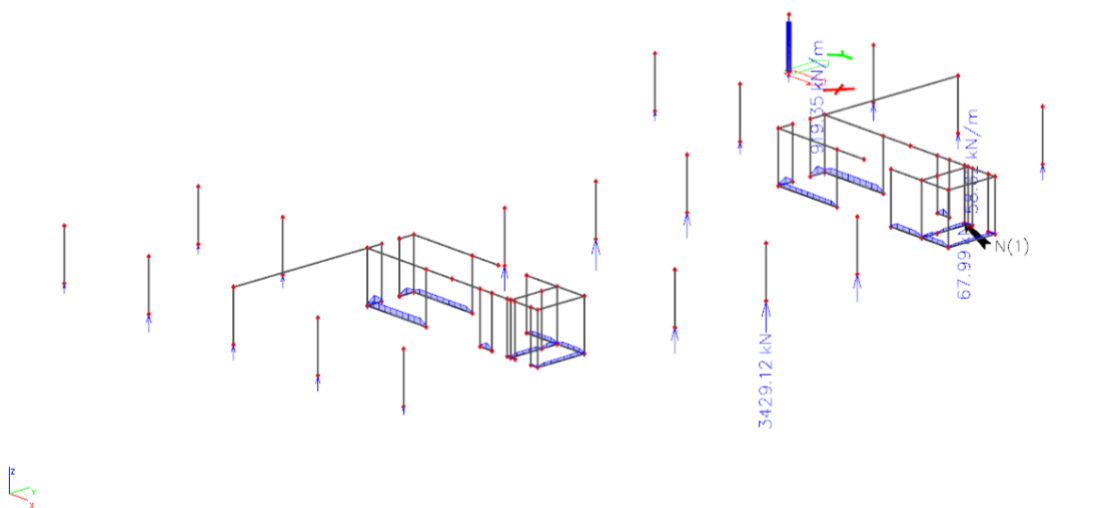

Slika 11.1 Maksimalna reakcija N (kN/m) za G_{SN-1}

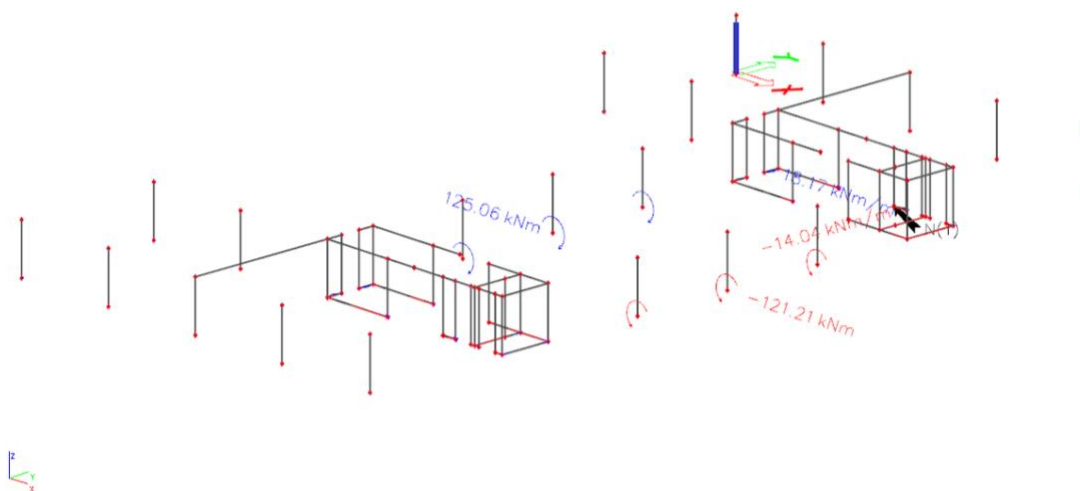

Slika 11.2 Pripadni moment za maksimalnu uzdužnu silu za G_{SN-1}

$$N_{\max}=3429.12 \text{ kN/m}; M_{\text{pripadni}}=121,21 \text{ kN}$$

$$\text{Širina i duljina temelja: } b \geq \sqrt{\frac{N_{Ed,0}}{\sigma_{Rd,t}}} = \sqrt{\frac{3429.12}{500}} = 2.61 \rightarrow \text{odabrano } b = 2.8 \text{ m}$$

$$\text{Visina temelja: odabrano } h = 0.6 \text{ m}$$

$$\text{Težina temelja: } N_{vt,t}=b^2 \cdot h \cdot \gamma_{ab} = 2.7^2 \cdot 0.6 \cdot 25 = 109.35 \text{ kN}$$

Ukupna sila kojom temelj opterećuje temeljnu plohu:

$$N_{Ed} = N_{Ed,y} + \gamma_q \cdot N_{vt,t} = 3429.12 + 1.35 \cdot 109.35 = 3576.74 \text{ kN}$$

$$A_t = 2.8 \cdot 2.8 = 7.84 \text{ m}^2$$

$$W_t = bh^2/6 = 3.66 \text{ m}^3$$

$$\sigma_{1,2} = \frac{N_{Ed}}{A_t} \pm \frac{M_{Ed}}{W_t} = \frac{3576.74}{7.84} \pm \frac{121.21}{3.66} = 456.21 \pm 33.11$$

$$\sigma_1 = 489.32 \text{ kN/m}^2$$

$$\sigma_2 = 423.10 \text{ kN/m}^2$$

$$\sigma_1, \sigma_2 < \sigma_{Rd,t} = 500 \text{ kN/m}^2$$

11.2 Proračun armature temelja

$$N_{\max}=3429.12 \text{ kN/m}; M_{\text{pripadni}}=121,21 \text{ Kn}$$

Dimenzije temelja:

$$b = 2.8 \text{ m}$$

$$b_1 = 1.05 \text{ m}$$

$$h = 0.6 \text{ m}$$

$$d = h - 0.05 = 0.55 \text{ m}$$

Momenti u presjeku 1-1

$$M_{1-1} = \sigma_{1-1} \cdot b_1 \cdot a \cdot \frac{b_1}{2} + (\sigma_1 - \sigma_{1-1}) \cdot \frac{b_1 \cdot a}{2} \cdot \frac{2}{3} \cdot b_1$$

$$\sigma_{1-1} = \sigma_1 - \frac{b_1}{b} \cdot (\sigma_1 - \sigma_2)$$

$$\sigma_{1-1} = 489.32 - \frac{1.05}{2.8} \cdot (489.32 - 423.10) = 464.49 \text{ kPa}$$

$$M_{1-1} = 464.49 \cdot 1.05 \cdot 2.8 \cdot \frac{1.05}{2} + (489.32 - 464.49) \cdot \frac{1.05 \cdot 2.8}{2} \cdot \frac{2}{3} \cdot 1.05 = 742.49 \text{ kNm}$$

$$\text{KLASA BETONA: C30/37} \rightarrow f_{ck} = 30 \text{ MPa} \rightarrow f_{cd} = \frac{30}{1.5} = 2.0 \text{ kN/cm}^2$$

$$\text{ZADANA ARMATURA: B500B} \rightarrow f_{yk} = 500 \text{ MPa} \rightarrow f_{yd} = \frac{500}{1.5} = 43.48 \text{ kN/cm}^2$$

$$\mu_{sd} = \frac{M_{Ed} \cdot 100}{b \cdot d^2 \cdot f_{cd}} = \frac{74249}{100 \cdot 55^2 \cdot 2} = 0.123$$

$$\text{Očitano: } \varepsilon_{s1} = 10.0 \text{ ‰} \quad \varepsilon_{c2} = 2.7 \quad \xi = 0.213 \quad \zeta = 0.916$$

$$A_{s1} = \frac{M_{Ed}}{\zeta \cdot d \cdot f_{cd}} = \frac{74249}{0.916 \cdot 55 \cdot 43.48} = 33.90 \text{ cm}^2$$

$$A'_{s1} = \frac{A_{s1}}{a} = \frac{33.90}{2.8} = 12.11 \text{ cm}^2/\text{m}'$$

Odabrana armature: mreža Q-785 i armaturene šipke $4\phi 12$ ($A_{s1} = 12.37 \text{ cm}^2/\text{m}'$)

Konstruktivna armature u gornjoj zoni: mreža Q-503 ($A_{s1} = 5.03 \text{ cm}^2/\text{m}'$)

12. GRAFIČKI PRILOZI

- Tlocrt temelja
- Tlocrt karakteristične etaže
- Presjek 1-1
- Presjek 2-2

TLOCRT TEMELJA

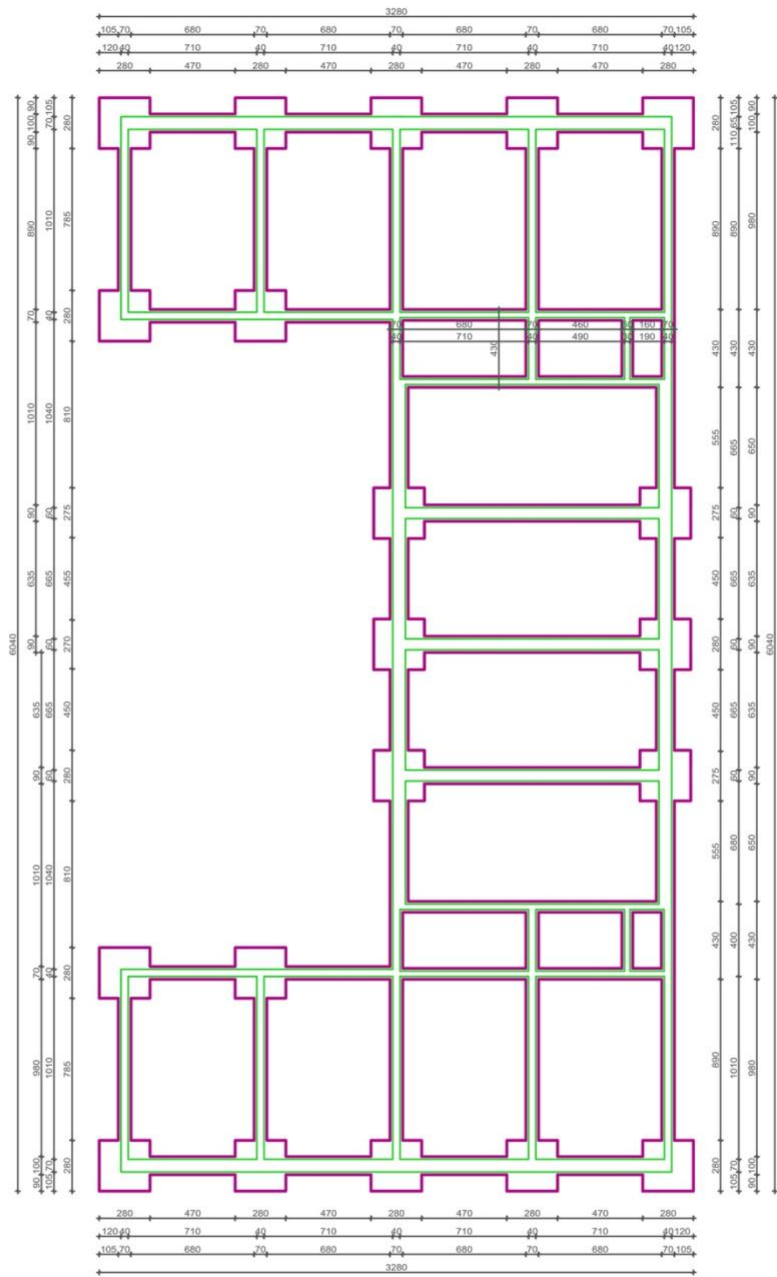

PREDMET	ZAVRSNI RAD
IZRADIO	IGOR POGANCIC
VI SEM	ŠK. GOD. 2020./2021.
TLOCRT FAKULTETA	
	MJ 1:100

TLOCRT KARAKTERISTIČNE
ETAŽE

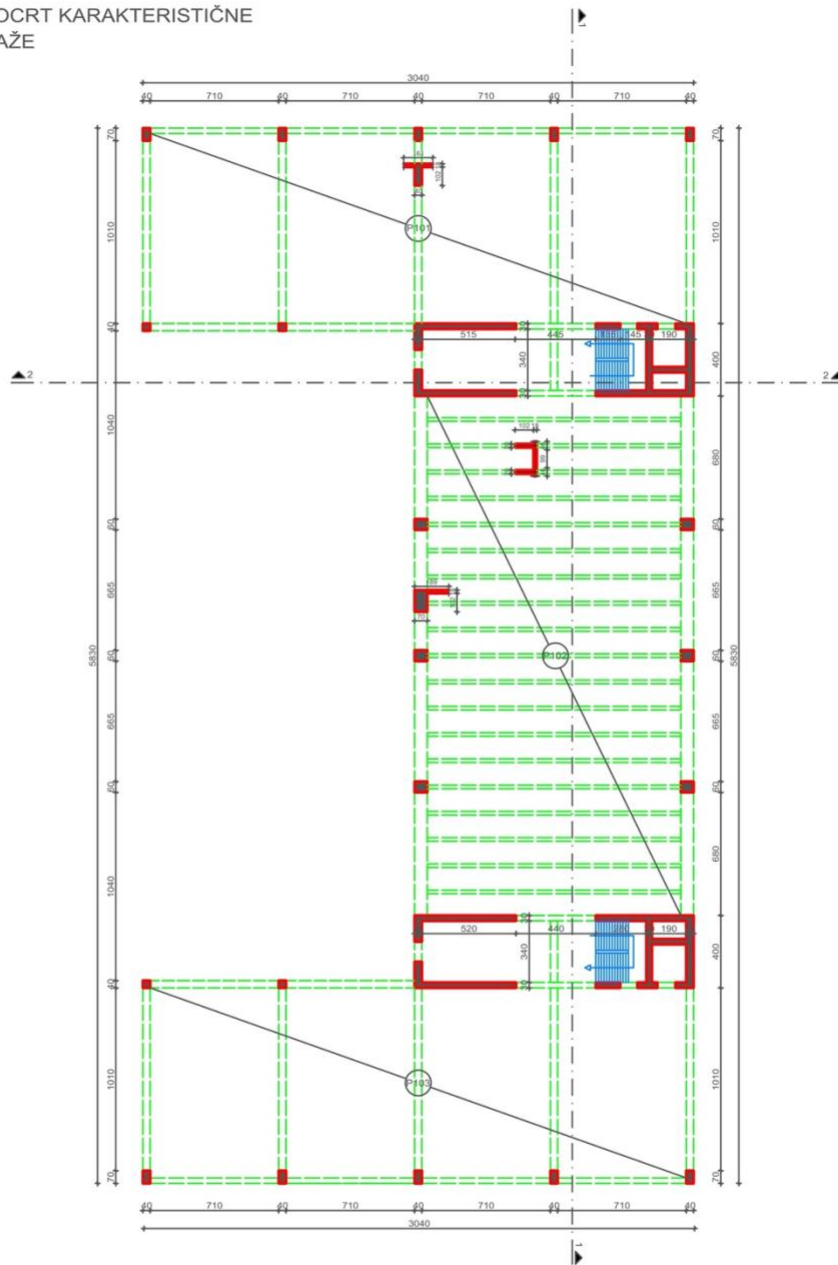

PREDMET	ZAVRSNI RAD
IZRADIO	IGOR POGANCIC
VI SEM	ŠK. GOD. 2020./2021.
TLOCRT FAKULTETA	
MJ 1:100	

PRESJEK 1-1

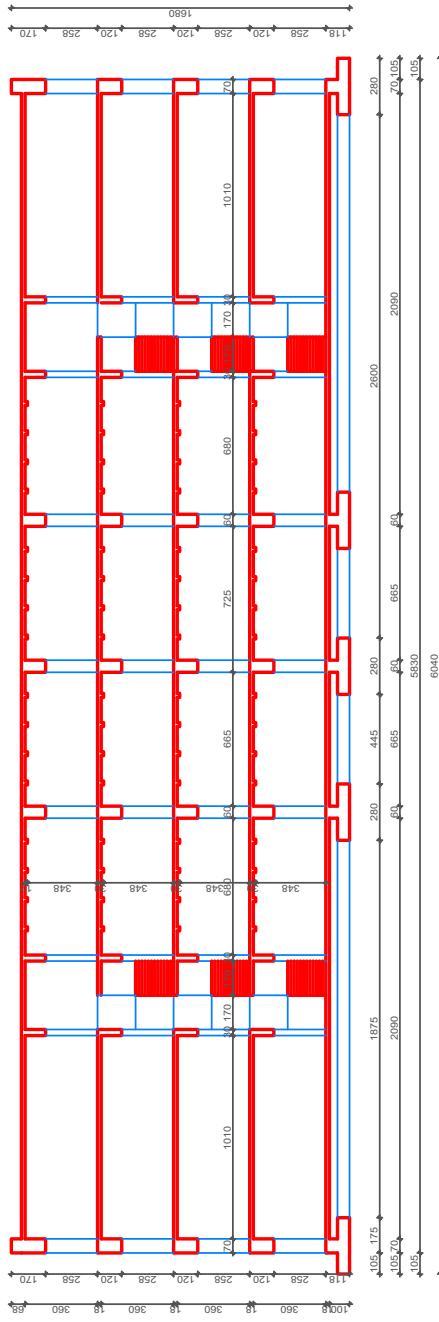

PREDMET	ZAVRSNI RAD
IZRADIO	IGOR POGANCIC
VI SEM	ŠK. GOD. 2020/2021.
TLOCRT FAKULTETA	
	MJ 1:100

PRESJEK 2-2

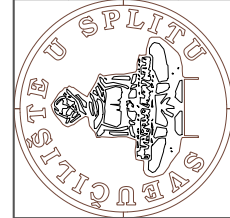
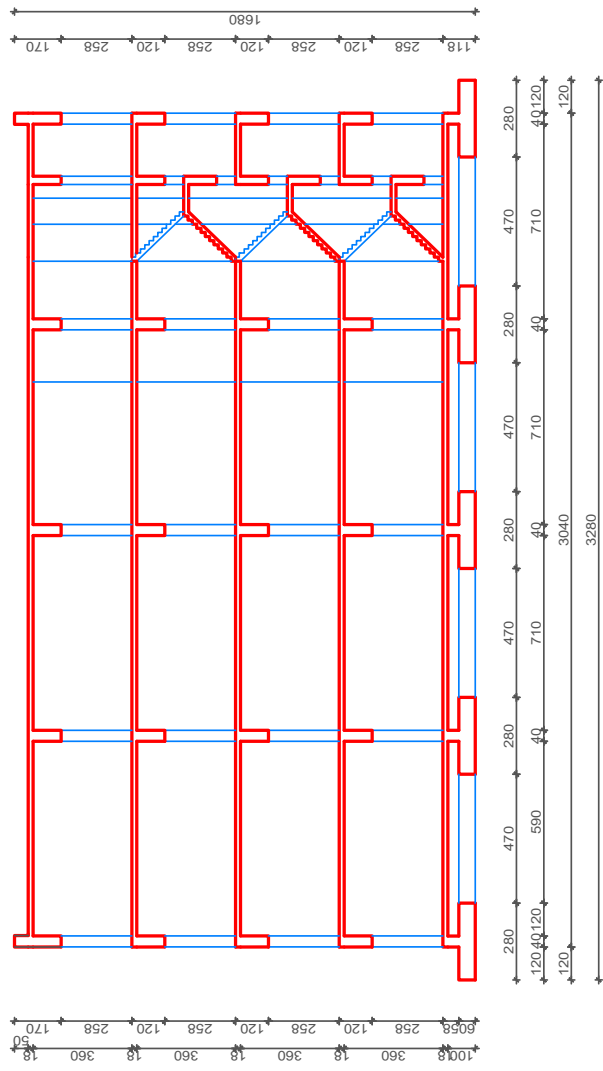

PREDMET	ZAVRSNI RAD
IZRADIO	IGOR POGANCIC
VI SEM	ŠK. GOD. 2020./2021.
TLOCRT FAKULTETA	
MJ 1:100	

13. LITERATURA

-Ante Mihanović, Boris Trogrlić, **Građevna statika I**, Sveučilište u Splitu, Fakultet građevinarstva, arhitekture i geodezije, Split 2011.

-Ante Mihanović, Boris Trogrlić, Vlaho Akmađić, **Građevna statika II**, Sveučilište u Splitu, Fakultet građevinarstva, arhitekture i geodezije, Split 2014.

-Ivan Tomičić, **Betonske konstrukcije**, Društvo hrvatskih građevinskih konstruktora, Zagreb 1996.

-Tanja Roje – Bonacci, Predrag Mišćević, **Temeljenje**, Fakultet građevinarstva, arhitekture i geodezije, Split 1997.

-Računalna analiza – “SCIA engineer 2021”.