

# Proračun čelične konstrukcije proizvodne hale

---

**Delaš, Ivan**

**Undergraduate thesis / Završni rad**

**2022**

*Degree Grantor / Ustanova koja je dodijelila akademski / stručni stupanj:*

**University of Split, Faculty of Civil Engineering, Architecture and Geodesy / Sveučilište u Splitu, Fakultet građevinarstva, arhitekture i geodezije**

*Permanent link / Trajna poveznica:* <https://um.nsk.hr/um:nbn:hr:123:422000>

*Rights / Prava:* [In copyright](#)/[Zaštićeno autorskim pravom.](#)

*Download date / Datum preuzimanja:* **2025-02-07**



*Repository / Repozitorij:*

[FCEAG Repository - Repository of the Faculty of Civil Engineering, Architecture and Geodesy, University of Split](#)



UNIVERSITY OF SPLIT



**SVEUČILIŠTE U SPLITU**  
**FAKULTET GRAĐEVINARSTVA, ARHITEKTURE I GEODEZIJE**

# **ZAVRŠNI RAD**

**Ivan Delaš**

**Split, 2022.**



**SVEUČILIŠTE U SPLITU**  
**FAKULTET GRAĐEVINARSTVA, ARHITEKTURE I GEODEZIJE**

# **ZAVRŠNI RAD**

**Ivan Delaš**

**Split, 2022.**

**SVEUČILIŠTE U SPLITU  
FAKULTET GRAĐEVINARSTVA, ARHITEKTURE I GEODEZIJE**

**Ivan Delaš**

**Proračun čelične konstrukcije proizvodne hale**

**Završni rad**

**Split, 2022.**

**SVEUČILIŠTE U SPLITU  
FAKULTET GRAĐEVINARSTVA, ARHITEKTURE I GEODEZIJE**

Split, Matice hrvatske 15

STUDIJ: **PREDDIPLOMSKI SVEUČILIŠNI STUDIJ GRAĐEVINARSTVA**  
KANDIDAT: **Ivan Delaš**  
MATIČNI BROJ (JMBAG): **0083219410**  
KATEDRA: **Katedra za metalne i drvene konstrukcije**  
PREDMET: **Osnove metalnih konstrukcija**

**ZADATAK ZA ZAVRŠNI RAD**

Tema: Proračun čelične konstrukcije proizvodne hale

Opis zadatka: Na temelju zadanih podataka čelične hale potrebno je dimenzionirati glavnu nosivu konstrukciju, sekundarne nosače te spregove konstrukcije.

Način izvedbe: montažno

Materijal konstrukcije: S 355

Objekt se nalazi na području Osijeka.

Razmak okvira: 5,4 (m)

U Splitu, 28.03.2022.

Voditelj Završnog rada:

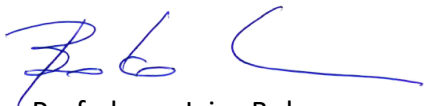

Prof. dr. sc. Ivica Boko

# Proračun čelične konstrukcije proizvodne hale

## **Sažetak:**

Na temelju zadanih podataka čelične hale potrebno je dimenzionirati glavnu nosivu konstrukciju, sekundarne nosače te spregove konstrukcije. Objekt se nalazi na području Osijeka. Proračun se provodi na temelju graničnog stanja nosivosti (GSN) i graničnog stanja uporabljivosti (GSU). Opterećenja koja se javljaju na konstrukciji su stalno: vlastita težina i promjenjivo: snijeg i vjetar. Rezultati unutarnjih sila dobiveni su u računalnom programu „Scia Engineer 2021“.

## **Ključne riječi:**

Čelik, hala, nosiva konstrukcija, stup, rešetka, podrožnica, spregovi, dimenzioniranje, spojevi

# Design of a steel manufacturing hall

## **Abstract:**

Based on the information about a steel manufacturing hall, we are required to design its main supporting structure, secondary structure and bracings. The object is located in Osijek. The estimate is based on the ultimate limit state (ULS) and serviceability limit states (SLS). The loads which appear on this object are permanent: self weight, and variable: snow and wind. Internal forces are derived from „Scia Engineer 2021“.

## **Keywords:**

Steel, hall, supporting structure, column, grating, purlin, bracing, design, joints

---

# SADRŽAJ

---

## 1. TEHNIČKI OPIS

- 1.1. KONSTRUKTIVNI SUSTAV
- 1.2. STATIČKA ANALIZA SUSTAVA
- 1.3. KONSTRUKTIVNI ELEMENTI
- 1.4. SPOJEVI
- 1.5. PRIMIJENJENI PROPISI
- 1.6. MONTAŽA I TRANSPORT
- 1.7. ZAŠTITA OD KOROZIJE
- 1.8. ZAŠTITA OD POŽARA

## 2. OPĆI PODACI, GEOMETRIJA I ANALIZA OPTEREĆENJA

- 2.1. OPĆI PODACI I GEOMETRIJA NOSIVOG SUSTAVA
- 2.2. ANALIZA OPTEREĆENJA

## 3. KONTROLA PROGIBA (GSU)

- 3.1. VERTIKALNI PROGIB U SREDINI DONJEG POJASA REŠETKE
- 3.2. HORIZONTALNI PROGIB VRHA STUPA

## 4. DIJAGRAMI REZNIH SILA ZA KOMBINACIJE DJELOVANJA (GSN)

- 4.1.1. GLAVNA NOSIVA KONSTRUKCIJA
- 4.1.2. ZABATNI STUPOVI
- 4.1.3. KROVNE PODROŽNICE
- 4.1.4. BOČNE PODROŽNICE
- 4.1.5. KROVNI SPREG
- 4.1.6. BOČNI SPREG

## 5. DIMENZIONIRANJE ELEMENATA KONSTRUKCIJE

### 5.1. GLAVNA NOSIVA KONSTRUKCIJA

- 5.1.1. GORNJI POJAS
- 5.1.2. DONJI POJAS
- 5.1.3. VERTIKALE
- 5.1.4. DIJAGONALE
- 5.1.5. STUPOVI

### 5.2. SEKUNDARNA NOSIVA KONSTRUKCIJA

- 5.2.1. ZABATNI STUPOVI
- 5.2.2. KROVNI SPREGOVI
- 5.2.3. BOČNI SPREGOVI
- 5.2.4. KROVNE PODROŽNICE
- 5.2.5. BOČNE PODROŽNICE
- 5.2.6. VERTIKALE SPREGA



## **6. DIMENZIONIRANJE SPOJEVA**

- 6.1. SPOJ STUP - TEMELJ
- 6.2. VLAČNI NASTAVAK
- 6.3. SPOJ STUP - REŠETKA

## **7. PRORAČUN TEMELJA**

## **8. NACRTI**

- 8.1. GENERALNI PLAN POZICIJA
- 8.2. PRESJEK KROZ GLAVNI OKVIR
- 8.3. RADIONIČKI NACRT GLAVNOG NOSAČA
- 8.4. RADIONIČKI NACRT SEKUNDARNE KONSTRUKCIJE
- 8.5. DETALJI SPOJEVA

## **9. PREDMJER MATERIJALA ZA CIJELU KONSTRUKCIJU**

## **10. LITERATURA**

## 1. TEHNIČKI OPIS

---

### 1.1. KONSTRUKTIVNI SUSTAV

Glavni nosivi sustav objekta sastoji se od 11 okvira raspona  $L = 22$  m na međusobnom osnom razmaku od 5,4 m. Sustav krova je rešetkasti nosač složenog oblika, a visina nosača u tjemenu iznosi  $h = 2,26$  m. Visina stupova okvira iznosi  $H = 5,5$  m, pa je ukupna visina okvira  $H_{uk} = 7,76$  m. Krovna ploha je u odnosu na horizontalnu ravninu pod nagibom od 9% .

### 1.2. STATIČKA ANALIZA SUSTAVA

Proračun je napravljen prema EURONORMAMA - HRN EN 1991 (EC3). Konstrukcija je izložena djelovanju opterećenja od vlastite težine, snijega i vjetra. Proračun progiba i reznih sila izvršen je u računalnom programu Scia Engineer.

Konstrukcija se nalazi na području grada Osijek (I. vjetrovna zona). Lokalna kategorija terena je II. Odgovarajući koeficijenti za vjetar i za snijeg uzeti su prema tome iz propisanih tablica.

Spojevi su proračunati i dimenzionirani u programu IDEA StatiCa.

### 1.3. KONSTRUKTIVNI ELEMENTI

**Stupovi** su predviđeni kao europski širokopojasni vrućevaljani H profili HEA 280. Stupovi su oslonjeni na betonske temelje, tako da je na njihovom spoju upotrijebljena čelična ploča dimenzija 500 x 370 x 25 mm. Stupovi su vezani za temelj vijcima M24. Dimenzije i armatura temelja su analizirani u proračunu temelja.

**Rešetkasti nosač** je predviđen kao nosač izrađen od kvadratnih cjevastih (šupljih) profila. Sastoji se od gornjeg i donjeg pojasa, 11 vertikalna međusobnog osnog razmaka 2,2 m i 10 dijagonala. Gornji pojas napravljen je od profila 140x140x7.1 a donji pojas od profila 100x100x5. Vertikale i dijagonale rešetkastog nosača su poprečnog presjeka 80x40x4 mm.

**Podrožnica** prenosi opterećenja sa krovne plohe na primarne nosače (gornji pojas rešetke). Podrožnice su vijcima vezane za nosač. Krovne podrožnice su izrađene od profila IPE 160, dok su bočne podrožnice IPE 100 .Također je predviđena i zidna sekundarna konstrukcija na koju se zatvaraju zidni paneli za zatvaranje konstrukcije.

Kao dijagonale krovnih i bočnih **spregova** odabrane su čelične sajle  $\Phi 14$  mm dok se kao **vertikale spregova** koriste profili dimenzija 70x70x4.

## 1.4. SPOJEVI

### SPOJ STUP – TEMELJ

Spoj se izvodi podložnom pločom dimenzija 500/370/25 (mm) navarenom na kraj stupa i pričvršćenom vijcima M24 k.v. 8.8 nosivim na vlak i odrez, te sidrenim u armirano–betonski temelj. Između podložne ploče i armirano–betonskog temelja podlijeva se ekspandirajući mort.

### VLAČNI NASTAVAK REŠETKE

Spoj grede i grede na krovu ostvaruje se čeonom pločom dimenzija 300/300/15 (mm) i vijcima M24 k.v. 8.8 nosivim na vlak i odrez

### SPOJ STUP – REŠETKA

Spoj grede na pojas stupa ostvaruje se čeonom pločom dimenzija 300/285/10 (mm), ukrutom i vijcima M12 k.v. 8.8 nosivim na vlak i odrez.

## 1.5. PRIMIJENJENI PROPISI

Proračun čelične konstrukcije hale proveden je prema sljedećim propisima:

Analiza opterećenja

HRN EN 1991-2-1

vlastita težina građevine

HRN EN 1991-2-3

djelovanje snijega na konstrukciju

HRN EN 1991-2-4

djelovanje vjetra

na konstrukciju

Dimenzioniranje

HRN EN 1993

dimenzioniranje čeličnih konstrukcija

HRN EN 1992

dimenzioniranje armirano-betonskih konstrukcija

## 1.6. MONTAŽA I TRANSPORT

Pozicije okvira kao što je prikazano u radioničkom nacrtu glavnog okvira će se izrezati u radionici te transportirati na gradilište i zatim montirati (montažni način izgradnje). Pri tome je potrebno obratiti posebnu pažnju na montažu i transport da bi se izbjegla nepotrebna oštećenja. Izvođač je dužan izraditi plan montaže nosača kojeg treba zajedno sa transportnim planom dostaviti nadzornoj službi na suglasnost. Potrebno je poduzeti sve mjere u skladu s „Pravilnikom o zaštiti na radu“.

## 1.7. ZAŠTITA OD KOROZIJE

Svi dijelovi čelične konstrukcije moraju biti zaštićeni od korozije prema odredbama „Pravilnika o tehničkim mjerama i uvjetima za zaštitu čelične konstrukcije od korozije“. Kao vrsta zaštite od korozije odabrana je zaštita premazom boja.

## **1.8. ZAŠTITA OD POŽARA**

U svrhu produljenja zagrijavanja konstruktivnih elemenata predmetne hale, svi takvi elementi moraju se zaštititi posebnim premazima otpornim na visoke temperature. Također je potrebno opremiti objekt za slučaj nastanka požara uređajima za najavu požara kao i opremom za njegovo gašenje.

## 2. OPĆI PODACI, GEOMETRIJA I ANALIZA OPTEREĆENJA

### 2.1. OPĆI PODACI I GEOMETRIJA NOSIVOG SUSTAVA

Krovni rešetkasti nosač + stupovi

---

Raspon:	$L = 22,0 \text{ m}$
Nagib krovne plohe:	$\alpha = \text{tg}\alpha = 0,99/11 \rightarrow \alpha = 5,1^\circ$ (kosi krov)
Visina stupova:	$H = 5,5 \text{ m}$
Visina rešetkastog nosača:	$h = 1,27 + 0,99 = 2,26 \text{ m}$
Ukupna visina nosivog sustava:	$H_{\text{uk}} = 5,5 + 2,26 = 7,76 \text{ m}$
Broj polja rešetke:	10 polja
Razmak vertikalnih podrožnica:	$L/10 = 22/10 = 2,2 \text{ m}$
Razmak bočnih podrožnica:	$H/3 = 5,5/3 = 1,83 \text{ m}$
Razmak vertikala rešetke:	$a = 2,2 \text{ m}$ ( $x = 2,21 \text{ m}$ )
Razmak nosača:	$n = 5,4 \text{ m}$

Prikaz konstrukcije (tlocrt, pogled) sa svim kotama:

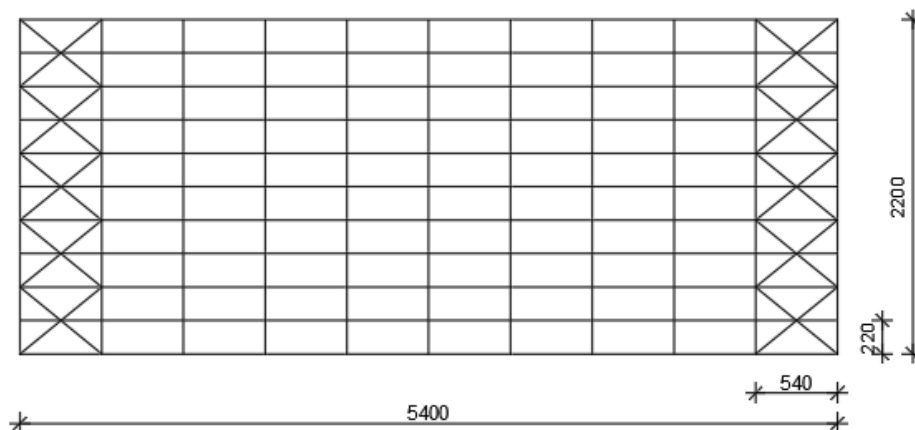
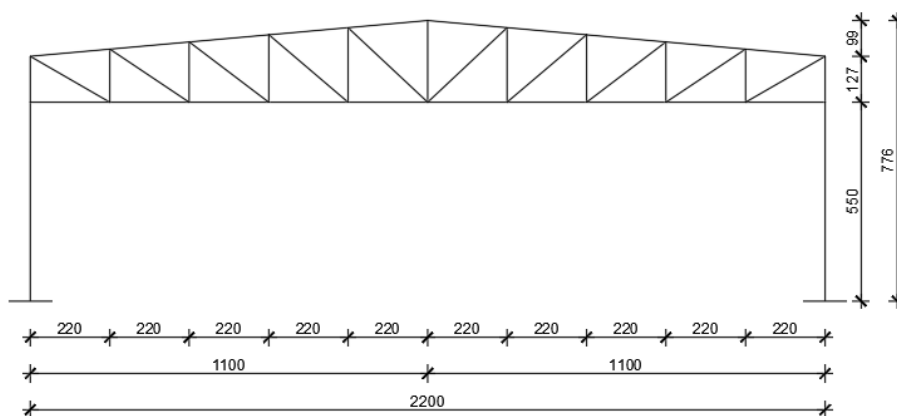

## 2.2. ANALIZA OPTEREĆENJA

### 2.2.1. Stalno opterećenje

*Krovna ploha:*

Sendvič – paneli 0,2 kN/m<sup>2</sup>

Sekundarna konstrukcija 0,2 kN/m<sup>2</sup>

Instalacije 0,1 kN/m<sup>2</sup>

---

$\Delta G = 0,5 \text{ kN/m}^2$

$$G = \Delta G * n * x = 0,50 * 5,4 * 2,21 = 5,97 \text{ kN}$$

*Stalno opterećenje u čvorovima okvira*

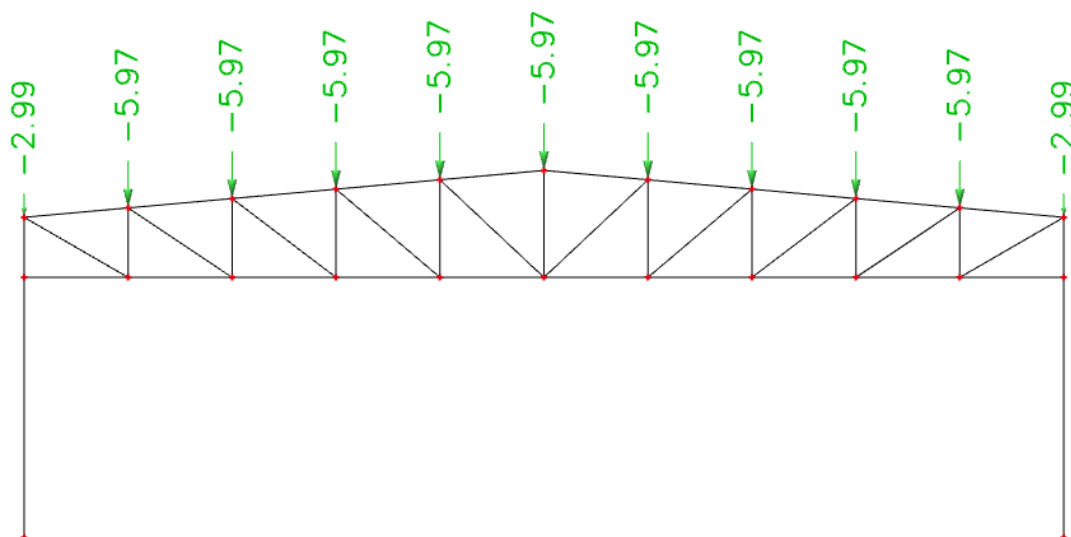

### 2.2.2. Djelovanje snijega

$$s = s_k * \mu_i * C_e * C_t \text{ [kN/m}^2\text{]}$$

$\mu_i$  - koeficijent oblika opterećenja snijegom

$s_k$  - karakteristična vrijednost opterećenja snijegom na tlu u  $\text{kN/m}^2$

$C_e$  - koeficijent izloženosti (obično se usvaja vrijednost 1,0)

$C_t$  - toplinski koeficijent (obično se usvaja vrijednost 1,0)

$$s_k = 1,0 \text{ kN/m}^2 \text{ za Osijek}$$

Nagib krova:

$\mu_i$  - koeficijent oblika za opterećenje snijegom, očitamo ga ovisno o  $\alpha$  (nagib krova)

$$\mu_i = 0,8 \rightarrow \text{za nagib krova } 0^\circ < \alpha < 30^\circ$$

Opterećenje snijegom preko cijele krovne površine:

$$s = 1,0 * 0,8 * 1,0 * 1,0 = 0,8 \text{ kN/m}^2$$

$$S = s * n * e = 0,8 * 5,4 * 2,21 = 9,5 \text{ kN}$$

Opterećenje snijegom u čvorovima okvira

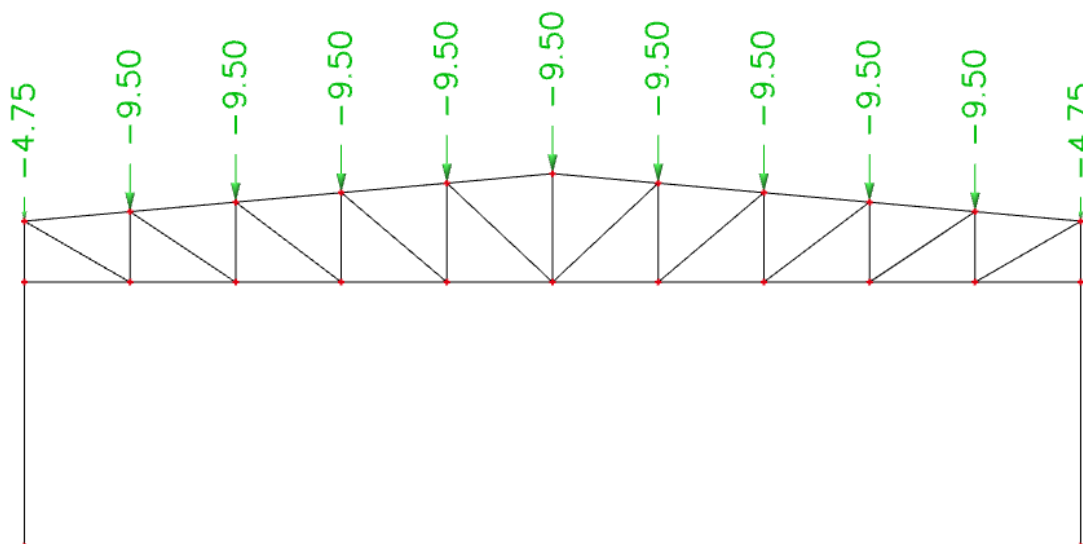

### 2.2.3. Proračun djelovanja vjetra

- pritisak vjetra na vanjske površine:  $w_e = q_p |z_e| * c_{pe} [kN/m^2]$

- pritisak vjetra na unutarnje površine:  $w_i = q_p |z_i| * c_{pi} [kN/m^2]$

gdje je:

$q_p(z_e)$  → pritisak vjetra pri udaru

$z_{e(i)}$  → referentna visina za vanjski (unutarnji) pritisak

$c_{pe}$  → vanjski koeficijent pritiska

$c_{pi}$  → unutarnji koeficijent pritiska

*Pozitivni i negativni koeficijenti pritiska vjetra*

Određivanje pritiska brzine vjetra pri udaru

Osnovni pritisak vjetra  $q_b$  određuje se prema formuli:

$$q_b = \frac{1}{2} * \rho * v_b^2 [kN/m^2]$$

gdje je:

$\rho$  - gustoća zraka (usvaja se vrijednost iz propisa 1,25 kg/m<sup>3</sup>)

$v_{b,0}$  - fundamentalna vrijednost osnovne brzine vjetra (očitava se iz karte)

(Osijek  $v_{b,0} = 20$  m/s)

$$q_b = \frac{1}{2} * 1,25 * 20^2 = 250 N/m^2$$

Osnovna brzina vjetra računa se prema izrazu:

$$v_b = c_{dir} * c_{season} * v_{b,0} [m/s]$$

gdje je:

$v_b$  – osnovna brzina vjetra

$c_{dir}$  – faktor smjera vjetra (obično se uzima **1,0**)

$c_{season}$  – faktor doba godine (obično se uzima **1,0**)

$$v_b = 1,0 * 1,0 * 20 = 20 m/s$$

$z = 7,76$  m – visina objekta



II. kategorija terena →  $C_e(z) = 2,15$  - faktor izloženosti, odnosi se na pritisak te ovisi o visini iznad terena ( $z$ ) i kategoriji terena

Pritisak brzine vjetra pri udaru  $q_p(z)$  se računa kao:

$$q_p|z| = c_e|z| * q_b = 2,15 * 250 = 537,5 \text{ N/m}^2 = 0,54 \text{ kN/m}^2$$

**Pritisak vjetra na vanjske površine:**

*Vertikalne površine konstrukcije*

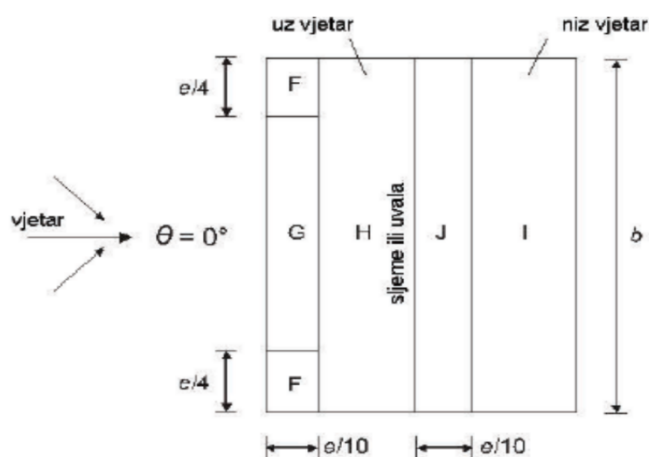

-parametar e:  $e = \min\{b; 2h\} = \min\{54; 15,52\} = 15,52\text{m}$

$$h/d = 7,76/22 = 0,35$$

Očitavamo koeficijente vanjskog pritiska za zone:

$\alpha=5,1^\circ$	F	G	H	I	J
$C_{pe10}$	-1,7	-1,2	-0,6	-0,6	+0,2

$\alpha=5,1^\circ$	F	G	H	I	J
$C_{pe10}$	+0,0	+0,0	+0,0	-0,6	-0,6

Unutarnji vjetar:

$$C_{p1} = + 0,2$$

$$C_{p2} = - 0,3$$

PODRUČJE	F	G	H	I	J
$C_{pe,10}$	-1,7	-1,2	-0,6	-0,6	+0,2
$W_{e1}$ (kN/m <sup>2</sup> )	-0,92	-0,65	-0,32	-0,32	+0,11

PODRUČJE	F	G	H	I	J
$C_{pe,10}$	+0,0	+0,0	+0,0	-0,6	-0,6
$W_{e1}$ (kN/m <sup>2</sup> )	+0,0	+0,0	+0,0	-0,32	-0,32

1. KOMBINACIJA (maksimalno odizanje) :  $q_p(z) \cdot (C_{pe10} + C_{pi1})$

$$F: w=0,54 \cdot (1,7+0,2)= -1,03 \text{ kN/ m}^2$$

$$G: w=0,54 \cdot (1,2+0,2)= -0,76 \text{ kN/ m}^2$$

$$H: w=0,54 \cdot (0,6+0,2)= -0,43 \text{ kN/ m}^2$$

$$I: w=0,54 \cdot (0,6+0,2)= -0,43 \text{ kN/ m}^2$$

$$J: w=0,54 \cdot (0,2-0,2)= 0,0 \text{ kN/ m}^2$$

$$F: W=5,4 \cdot (-1,03) = -5,56 \text{ kN/ m}$$

$$G: W=5,4 \cdot (-0,76) = -4,1 \text{ kN/ m}$$

$$H: W=5,4 \cdot (-0,43) = -2,32 \text{ kN/ m}$$

$$I: W=5,4 \cdot (-0,43) = -2,32 \text{ kN/ m}$$

$$J: W=5,4 \cdot 0,0 = 0,0 \text{ kN/ m}$$

2. KOMBINACIJA (maksimalni pritisak) :  $q_p(z) \cdot (C_{pe1} + C_{pi2})$

F1:  $w=0,54 \cdot (0,0+0,3)=0,16 \text{ kN/ m}^2$

G1:  $w=0,54 \cdot (0,0+0,3)=0,16 \text{ kN/ m}^2$

H1:  $w=0,54 \cdot (0,0+0,3)=0,16 \text{ kN/ m}^2$

I1:  $w=0,54 \cdot (0,2+0,3)= 0,27 \text{ kN/ m}^2$

J1:  $w=0,54 \cdot (0,2+0,3)= 0,27 \text{ kN/ m}^2$

F1:  $W=5,4 \cdot 0,16 = 0,86 \text{ kN/ m}$

G1:  $W=5,4 \cdot 0,16 = 0,86 \text{ kN/ m}$

H1:  $W=5,4 \cdot 0,16 = 0,86 \text{ kN/ m}$

I1:  $W=5,4 \cdot 0,27 = 1,46 \text{ kN/ m}$

J1:  $W=5,4 \cdot 0,27 = 1,46 \text{ kN/ m}$

-MJERODAVNE KOMBINACIJE: 1. (maksimalno odizanje) i 2. (maksimalni pritisak)

$H/d=0,35$

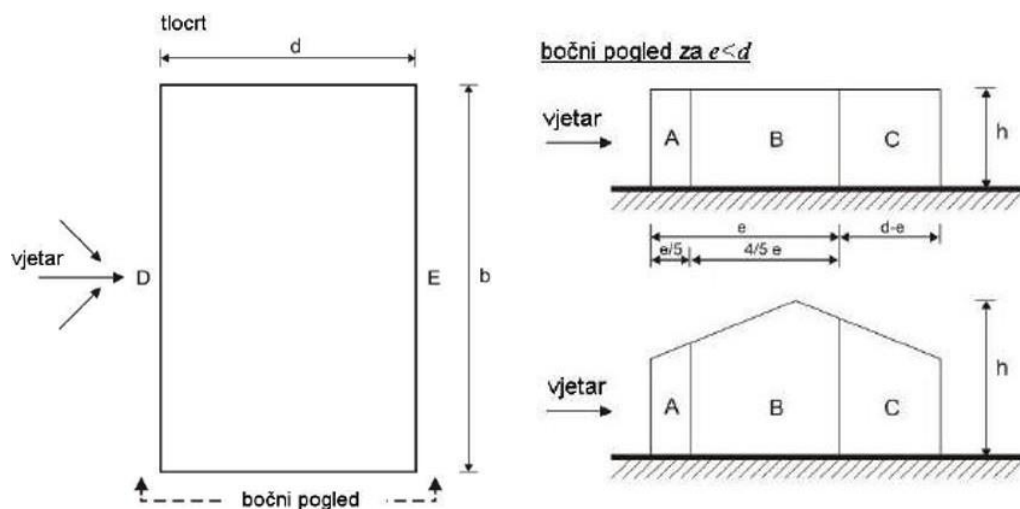

Slika 6 Prikaz područja vjetra za vertikalne zidove

- Koeficijenti vanjskog pritiska na halu za vertikalne zidove  $h/d=0,35$

PODRUČJE	A	B	C	D	E
$C_{pe,10}$	-1,2	-0,8	-0,5	+0,8	-0,5

Tablica 6 Vanjski koeficijenti pritiska prema područjima konstrukcije

### Određivanje koeficijenata unutarnjeg pritiska

Koeficijenti  $c_{pi}$  ovise o veličini i raspodjeli otvora na oblozi hale (fasada i krov). U ovom primjerunije definiran raspored i veličina otvora, zato se za vrijednost  $c_{pi}$  usvajaju vrijednosti:

Unutrašnji koeficijent pritiska  $\rightarrow c_{pi} = -0,3$  i  $+0,2$

Pritisak vjetra na vanjske površine

$$w_e = q_p \cdot c_{pe} \text{ [kN/m}^2\text{]}$$

$q_p = 0,54 \text{ kN/m}^2$  -preuzeto iz analize opterećenja glavne nosive konstrukcije

PODRUČJE	A	B	C	D	E
$c_{pe,10}$	-1,2	-0,8	-0,5	+0,8	-0,5
$w_e \text{ (kN/m}^2\text{)}$	-0,65	-0,43	-0,27	+0,43	-0,27

Tablica 7 Vanjski koeficijenti pritiska prema područjima konstrukcije

Pritisak vjetra na unutarnje površine

$$w_i = q_p \cdot c_{pi} \text{ [kN/m}^2\text{]}$$

$$q_p = 0,54 \text{ kN/m}^2, c_i(z_i) = 2,0$$

$$w_i = 0,54 \cdot 0,2 = +0,11 \text{ kN/m}^2$$

$$w_i = 0,54 \cdot (-0,3) = -0,16 \text{ kN/m}^2$$

Rezultirajuće djelovanje vjetra

$$w_k = w_e - w_i \text{ [kN/m}^2\text{]}$$

**1.KOMBINACIJA (pozitivni unutarnji pritisak) :  $q_p(z) \cdot (C_{pe10} + C_{pi1})$**

A:  $w=0,54 \cdot (1,2+0,2) = -0,76 \text{ kN/ m}^2$

B:  $w=0,54 \cdot (0,8+0,2) = -0,54 \text{ kN/ m}^2$

C:  $w=0,54 \cdot (0,5+0,2) = -0,38 \text{ kN/ m}^2$

D:  $w=0,54 \cdot (0,8-0,2) = +0,32 \text{ kN/ m}^2$

E:  $w=0,54 \cdot (0,5+0,2) = -0,38 \text{ kN/ m}^2$

A:  $W=5,4 \cdot (-0,76) = -4,1 \text{ kN/ m}$

B:  $W=5,4 \cdot (-0,54) = -2,92 \text{ kN/ m}$

C:  $W=5,4 \cdot (-0,38) = -2,05 \text{ kN/ m}$

D:  $W=5,4 \cdot 0,32 = +1,73 \text{ kN/ m}$

E:  $W=5,4 \cdot (-0,38) = -2,05 \text{ kN/ m}$

**2.KOMBINACIJA (negativni unutarnji pritisak) :  $q_p(z) \cdot (C_{pe10} + C_{pi2})$**

A:  $w=0,54 \cdot (1,2-0,3) = -0,49 \text{ kN/ m}^2$

B:  $w=0,54 \cdot (0,8-0,3) = -0,27 \text{ kN/ m}^2$

C:  $w=0,54 \cdot (0,5-0,3) = -0,11 \text{ kN/ m}^2$

D:  $w=0,54 \cdot (0,8+0,3) = +0,59 \text{ kN/ m}^2$

E:  $w=0,54 \cdot (0,5-0,3) = -0,11 \text{ kN/ m}^2$

A:  $W=5,4 \cdot (-0,49) = -2,65 \text{ kN/ m}$

B:  $W=5,4 \cdot (-0,27) = -1,46 \text{ kN/ m}$

C:  $W=5,4 \cdot (-0,11) = -0,59 \text{ kN/ m}$

D:  $W=5,4 \cdot 0,59 = +3,20 \text{ kN/ m}$

E:  $W=5,4 \cdot (-0,11) = -0,59 \text{ kN/ m}$

**Sile u čvorovima od vjetra W1 (1. kombinacija):**

-Krov:

$W1 = 1,105 \cdot 4,1 = 4,53 \text{ kN}$

$W2 = 0,33 \cdot 4,1 + 1,88 \cdot 2,32 = 5,71 \text{ kN}$

$W3 = 2,21 \cdot 2,32 = 5,13 \text{ kN}$

$W4 = 2,21 \cdot 2,32 = 5,13 \text{ kN}$

$W5 = 2,21 \cdot 2,32 = 5,13 \text{ kN}$

$W6 = 1,105 \cdot 2,32 = 2,56 \text{ kN}$

$W7 = 1,105 \cdot 2,32 = 2,56 \text{ kN}$

$W8 = 2,21 \cdot 2,32 = 5,13 \text{ kN}$

$W9 = 2,21 \cdot 2,32 = 5,13 \text{ kN}$

$W10 = 2,21 \cdot 2,32 = 5,13 \text{ kN}$

$W11 = 2,21 \cdot 2,32 = 5,13 \text{ kN}$

$W12 = 1,105 \cdot 2,32 = 2,56 \text{ kN}$

-Stupovi:

$$W(D1) = 0,64 * (-1,73) = -1,11 \text{ kN}$$

$$W(D2) = 0,64 * (-1,73) + 0,92 * (-1,73) = -2,7 \text{ kN}$$

$$W(D3) = 1,83 * (-1,73) = -3,17 \text{ kN}$$

$$W(D4) = 1,83 * (-1,73) = -3,17 \text{ kN}$$

$$W(D5) = 0,92 * (-1,73) = -1,58 \text{ kN}$$

$$W(E1) = 0,64 * 2,05 = 1,31 \text{ kN}$$

$$W(E2) = 0,64 * 2,05 + 0,92 * 2,05 = 3,2 \text{ kN}$$

$$W(E3) = 1,83 * 2,05 = 3,75 \text{ kN}$$

$$W(E4) = 1,83 * 2,05 = 3,75 \text{ kN}$$

$$W(E5) = 0,92 * 2,05 = 1,88 \text{ kN}$$

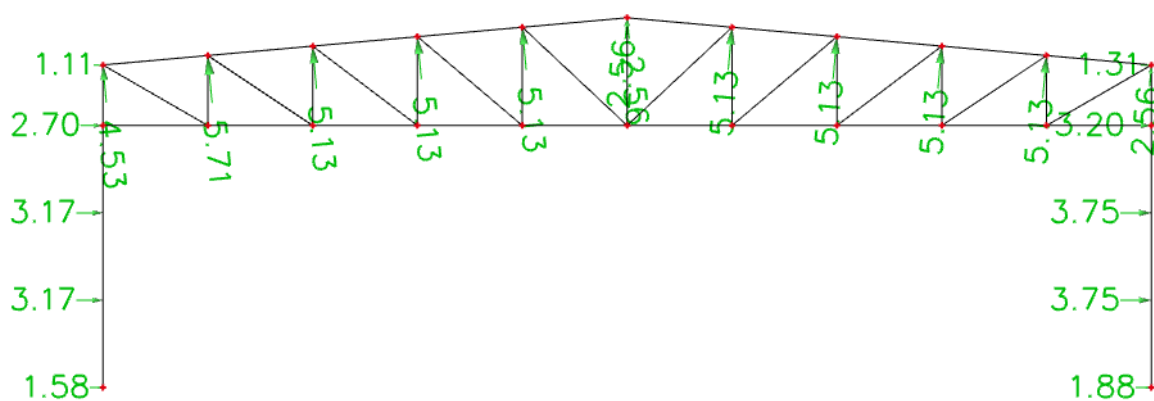

## Sile u čvorovima od vjetra W2 (2. kombinacija):

-Krov:

$$W1 = 1,105 * 0,86 = 0,95 \text{ kN}$$

$$W2 = 2,21 * 0,86 = 1,9 \text{ kN}$$

$$W3 = 2,21 * 0,86 = 1,9 \text{ kN}$$

$$W4 = 2,21 * 0,86 = 1,9 \text{ kN}$$

$$W5 = 2,21 * 0,86 = 1,9 \text{ kN}$$

$$W6 = 1,105 * 0,86 = 0,95 \text{ kN}$$

$$W7 = 1,105 * 1,46 = 1,61 \text{ kN}$$

$$W8 = 2,21 * 1,46 = 3,23 \text{ kN}$$

$$W9 = 2,21 * 1,46 = 3,23 \text{ kN}$$

$$W10 = 2,21 * 1,46 = 3,23 \text{ kN}$$

$$W11 = 2,21 * 1,46 = 3,23 \text{ kN}$$

$$W12 = 1,105 * 1,46 = 1,61 \text{ kN}$$

-Stupovi:

$$W(D1) = 0,64 * (-3,20) = -2,05 \text{ kN}$$

$$W(D2) = 0,64 * (-3,20) + 0,92 * (-3,20) = -4,99 \text{ kN}$$

$$W(D3) = 1,83 * (-3,20) = -5,86 \text{ kN}$$

$$W(D4) = 1,83 * (-3,20) = -5,86 \text{ kN}$$

$$W(D5) = 0,92 * (-3,20) = -2,94 \text{ kN}$$

$$W(E1) = 0,64 * 0,59 = 0,38 \text{ kN}$$

$$W(E2) = 0,64 * 0,59 + 0,92 * 0,59 = 0,92 \text{ kN}$$

$$W(E3) = 1,83 * 0,59 = 1,08 \text{ kN}$$

$$W(E4) = 1,83 * 0,59 = 1,08 \text{ kN}$$

$$W(E5) = 0,92 * 0,59 = 0,54 \text{ kN}$$

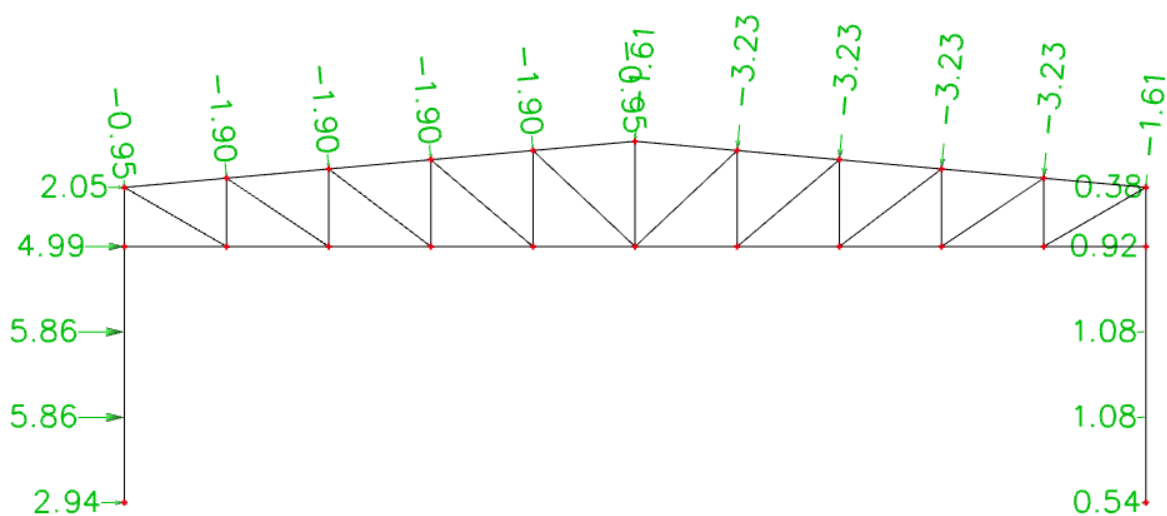

## Vjetar na zabatnim stupovima

PODRUČJE	D
$C_{pe,10}$	+0,8

Koeficijent unutrašnjeg pritiska:  $C_{pi} = 0,3$

$$W_z = 0,54 * (0,8 + 0,3) = 0,59 \text{ kn/m}^2$$

$$W_{z1} = 0,59 * 3,3 = 1,95 \text{ kn/m'}$$

$$W_{z2} = 0,59 * (3,3 + 2,2) = 3,25 \text{ kn/m'}$$

$$W_{z3} = 0,59 * 4,4 = 2,6 \text{ kn/m'}$$

$$W_{z4} = 0,59 * (2,2 + 3,3) = 3,25 \text{ kn/m'}$$

$$W_{z5} = 0,59 * 3,3 = 1,95 \text{ kn/m'}$$

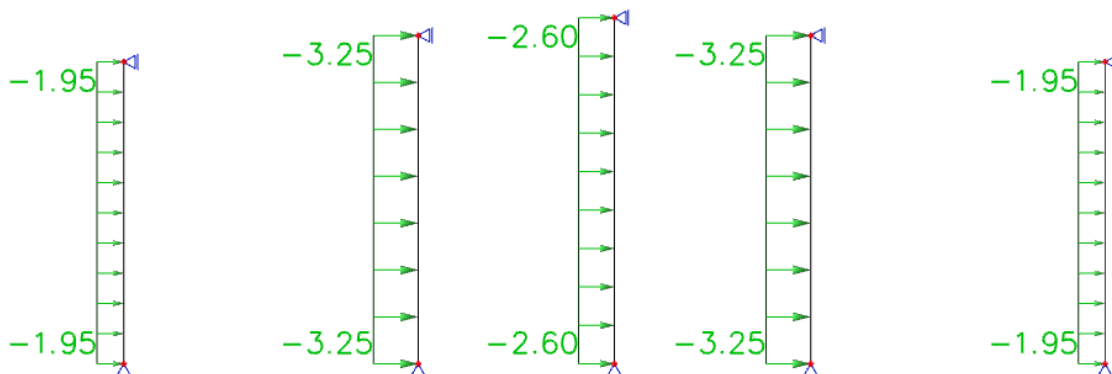



### 3. KONTROLA PROGIBA (GSU)

#### Kombinacije:

Kombinacija:  $GSU_1 = 1,00 * G + 1,00 * S + 1,00 * W_{\text{pritisak}}$

Kombinacija:  $GSU_2 = 1,00 * G + 1,00 * W_{\text{odizanje}}$

Odabrani profili za koje dobivamo vrijednosti progiba u iznosu od minimalno 80% dopuštenih progiba su:

- a) stup- HEA 280
- b) Gornji i donji pojas – CFRHS 50x50x5

#### 4.1. VERTIKALNI PROGIB U SREDINI DONJEG POJASA REŠETKE

GSU 1

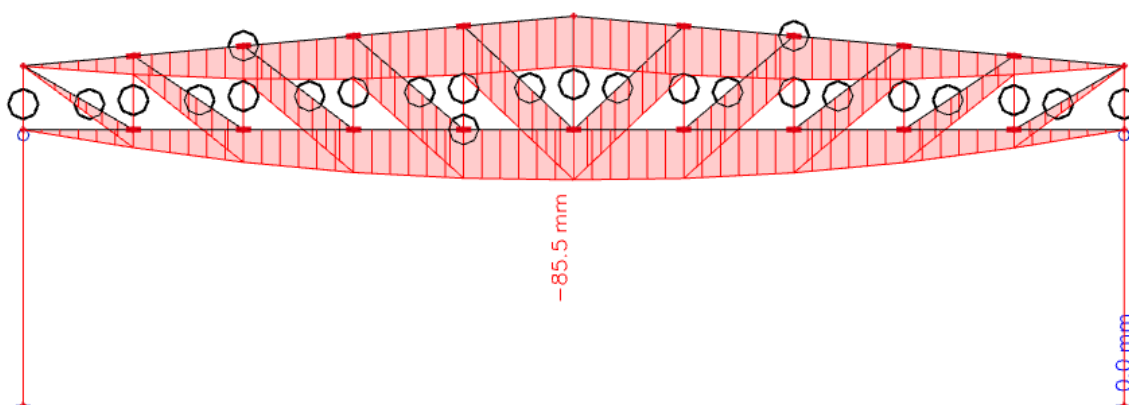

GSU 2

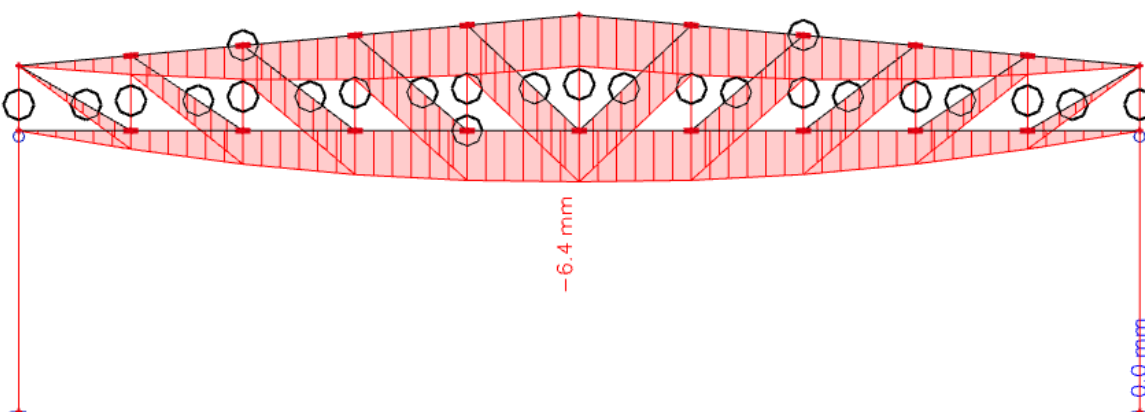

$$\text{Preporuka: } W_{\text{FIN.V}} \leq \frac{L}{250} = \frac{22 \cdot 1000 \text{ mm}}{250} = 88 \text{ mm}$$

$$W_{\text{GSU1}} = 85,50 \text{ mm}$$

$$W_{\text{GSU2}} = 6,40 \text{ mm}$$

Konačni progib zadovoljava uvjet uz iskoristivost od :  $\eta = \frac{85,50}{88} = 0,9716 = 97,16 \%$

## 4.2. HORIZONTALNI PROGIB VRHA STUPA

GSU 1

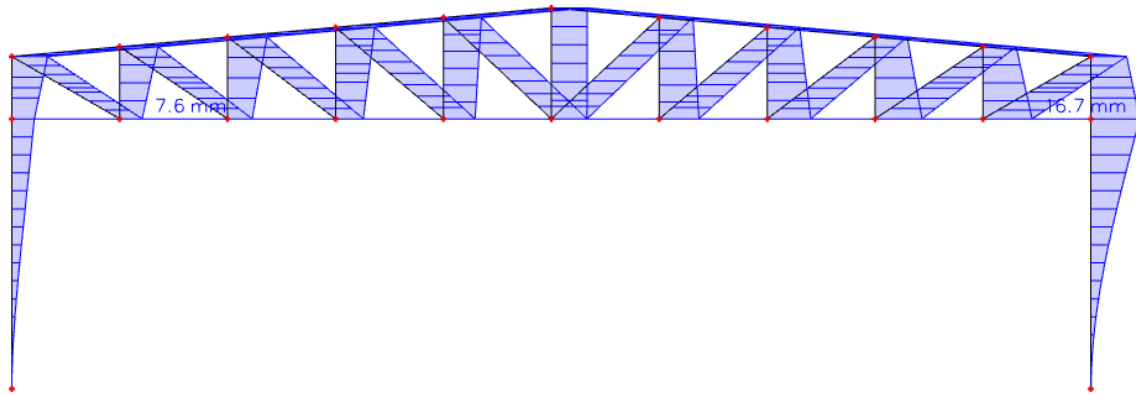

GSU 2

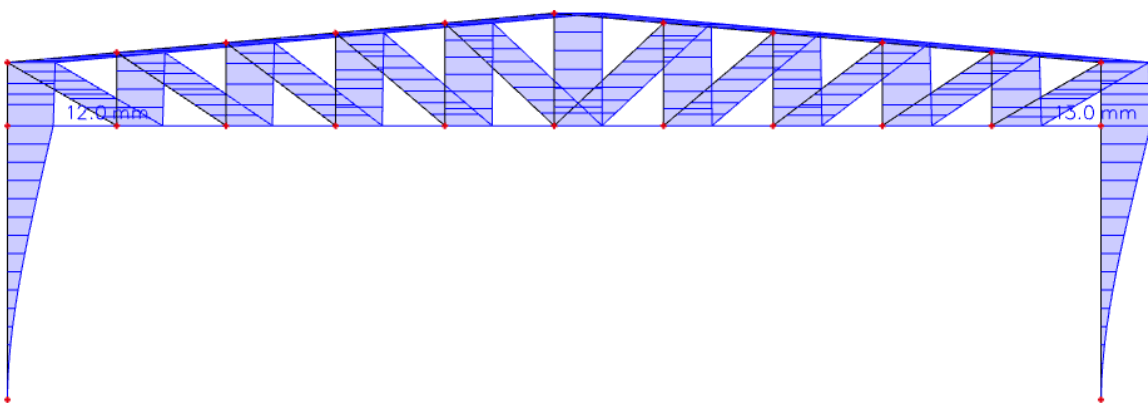

$$\text{Preporuka: } W_{\text{FIN.H}} \leq \frac{L}{300} = \frac{5,5 \cdot 1000 \text{ mm}}{300} = 18,33 \text{ mm}$$

$$W_{\text{GSU1}} = 16,7 \text{ mm}$$

$$W_{\text{GSU2}} = 13,0 \text{ mm}$$

Konačni progib zadovoljava uvjet uz iskoristivost od:  $\eta = \frac{16,70}{18,33} = 0,9111 = 91,11 \%$

## 4. DIJAGRAM REZNIH SILA ZA KOMBINACIJE DJELOVANJA (GSN)

### Kombinacije:

$$\text{Kombinacija: } GSN_1 = 1,35 * G + 0,9 * S + 1,5 * W_{\text{pritisak}}$$

$$\text{Kombinacija: } GSN_1 = 1,35 * G + 0,9 * W_{\text{pritisak}} + 1,5 * S$$

$$\text{Kombinacija: } GSN_2 = 1,00 * G + 1,50 * W_{\text{odizanje}}$$

### 4.1. Dijagrami reznih sila po modelima:

#### 4.1.1. Glavna nosiva konstrukcija

##### 1D internal forces

Values:  $M_y$

Linear calculation

Combination: GSN1

Coordinate system: Member

Extreme 1D: Member

Selection: All

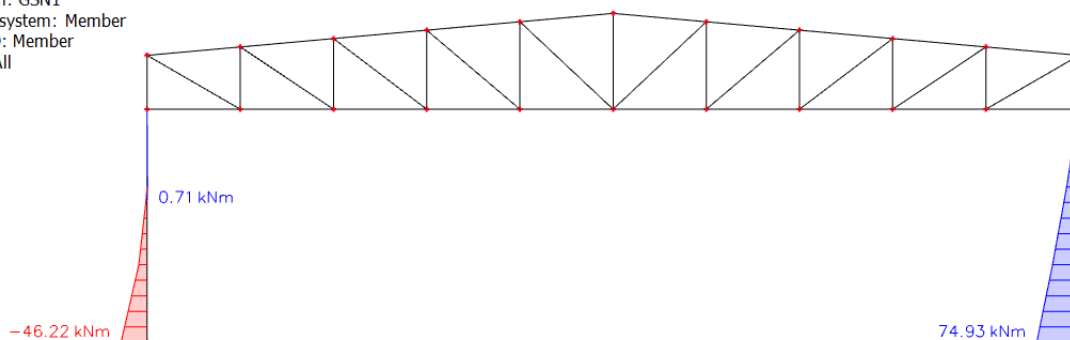

##### 1D internal forces

Values:  $V_z$

Linear calculation

Combination: GSN1

Coordinate system: Member

Extreme 1D: Member

Selection: All

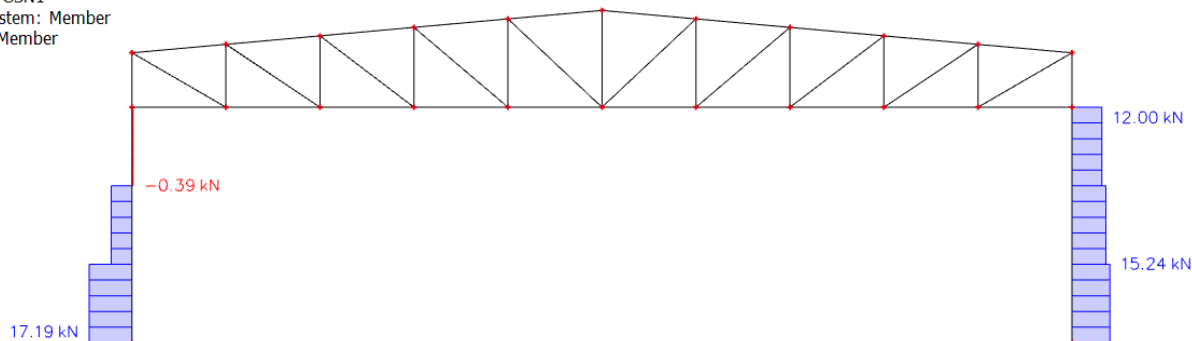

##### 1D internal forces

Values:  $N$

Linear calculation

Combination: GSN1

Coordinate system: Member

Extreme 1D: Member

Selection: All

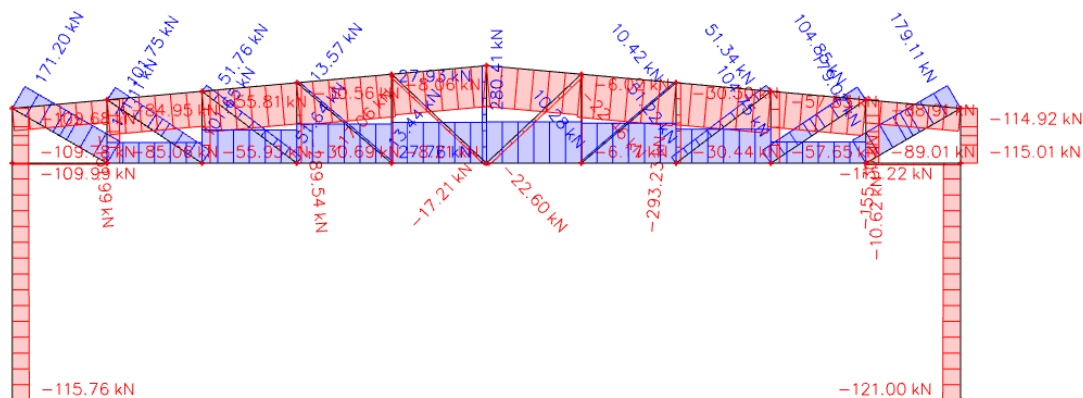

**1D internal forces**

Values:  $M_y$   
 Linear calculation  
 Combination: GSN2  
 Coordinate system: Member  
 Extreme 1D: Member  
 Selection: All

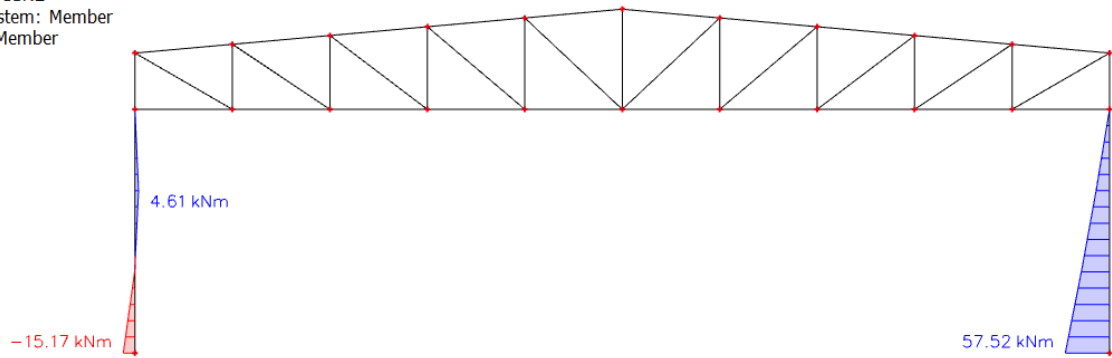

**1D internal forces**

Values:  $V_z$   
 Linear calculation  
 Combination: GSN2  
 Coordinate system: Member  
 Extreme 1D: Member  
 Selection: All

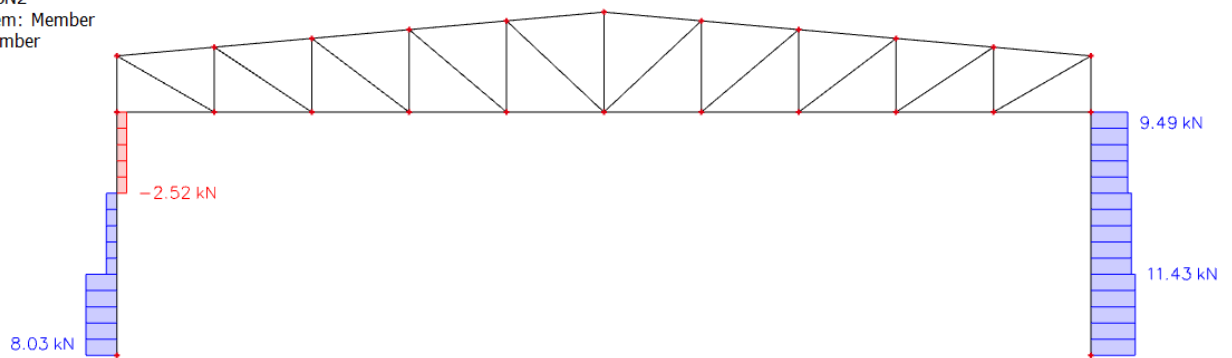

**1D internal forces**

Values:  $N$   
 Linear calculation  
 Combination: GSN2  
 Coordinate system: Member  
 Extreme 1D: Member  
 Selection: All

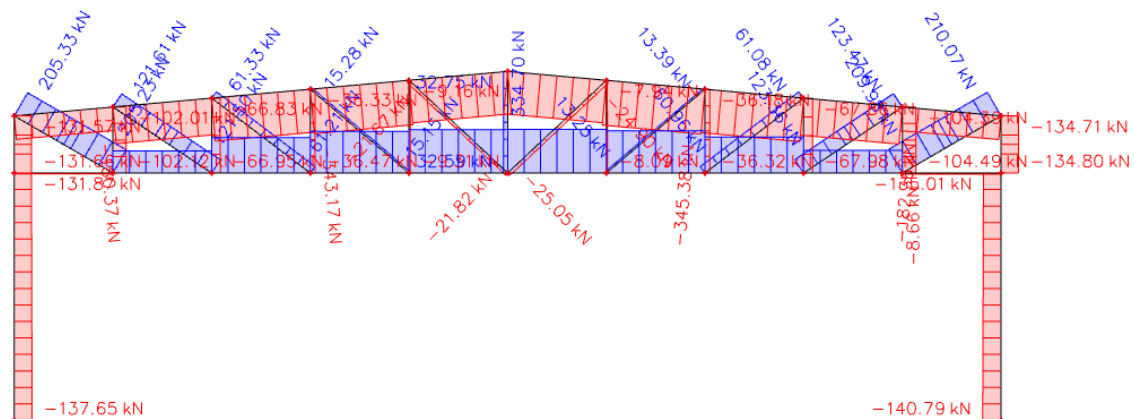

**1D internal forces**

Values:  $M_y$   
 Linear calculation  
 Combination: GSN3  
 Coordinate system: Member  
 Extreme 1D: Member  
 Selection: All

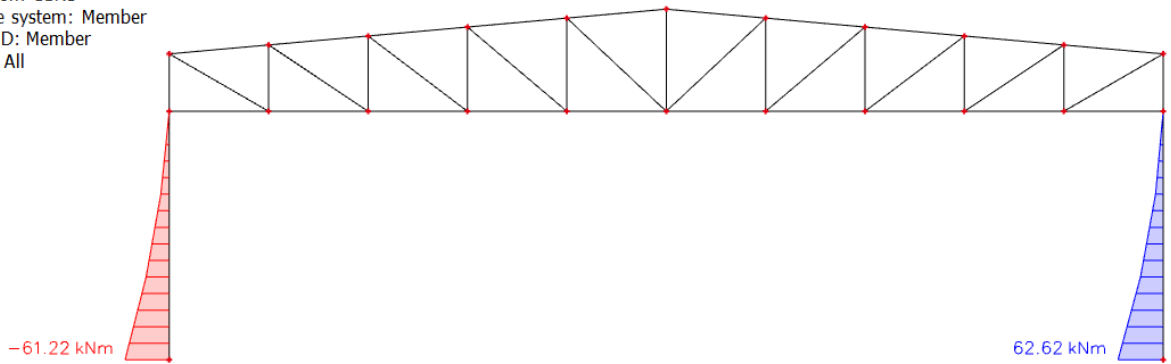

**1D internal forces**

Values:  $V_z$   
 Linear calculation  
 Combination: GSN3  
 Coordinate system: Member  
 Extreme 1D: Member  
 Selection: All

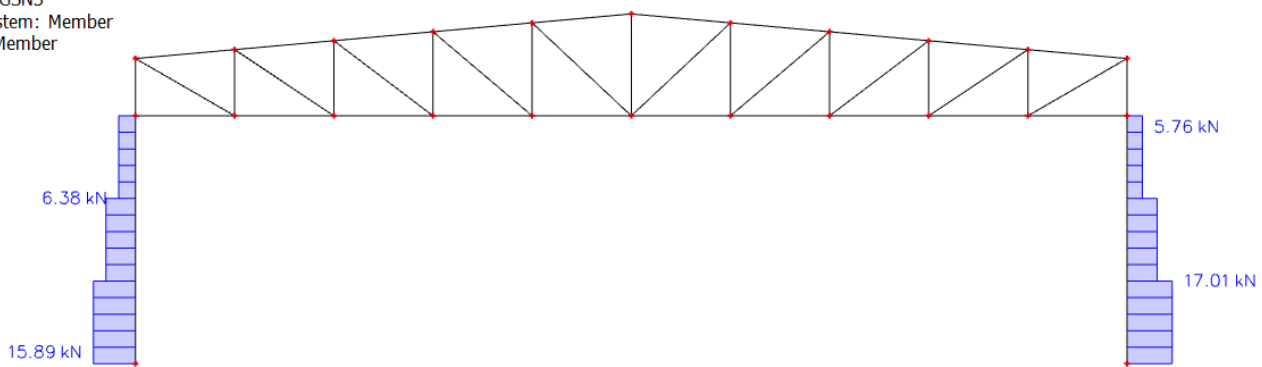

**1D internal forces**

Values:  $N$   
 Linear calculation  
 Combination: GSN3  
 Coordinate system: Member  
 Extreme 1D: Member  
 Selection: All

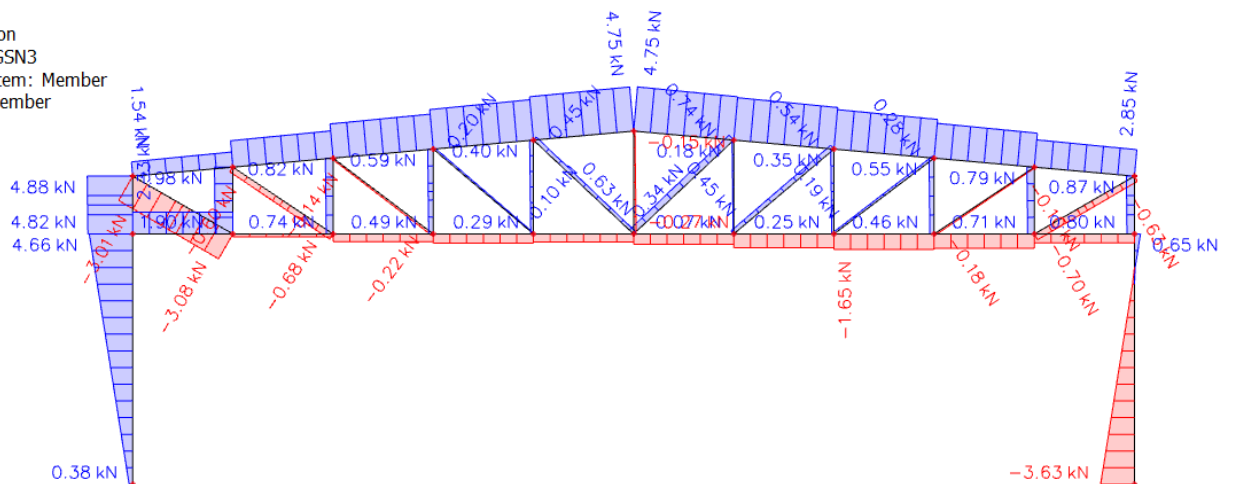

### 4.1.2. Zabatni stupovi

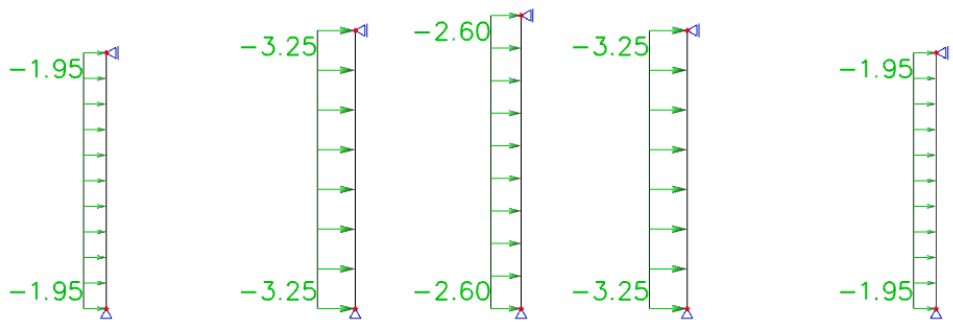

**1D internal forces**

Values:  $M_y$   
 Linear calculation  
 Combination: zabatni vjetar  
 Coordinate system: Member  
 Extreme 1D: Member  
 Selection: All

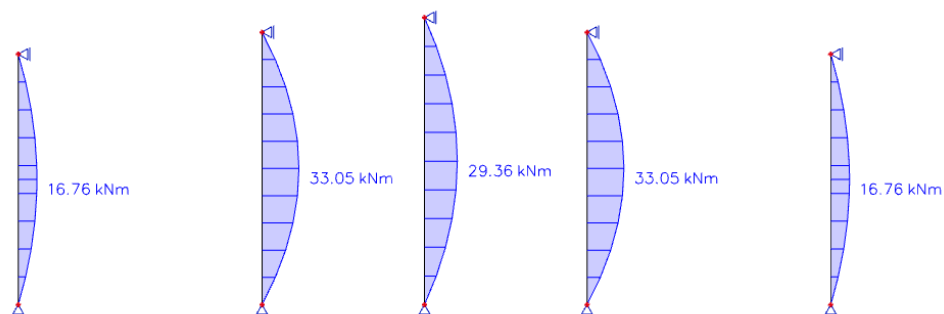

**1D internal forces**

Values:  $V_z$   
 Linear calculation  
 Combination: zabatni vjetar  
 Coordinate system: Member  
 Extreme 1D: Member  
 Selection: All

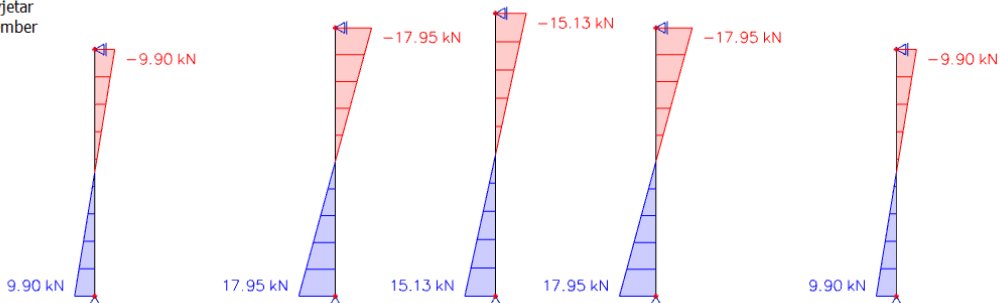

**1D internal forces**

Values:  $N$   
 Linear calculation  
 Combination: zabatni vjetar  
 Coordinate system: Member  
 Extreme 1D: Member  
 Selection: All

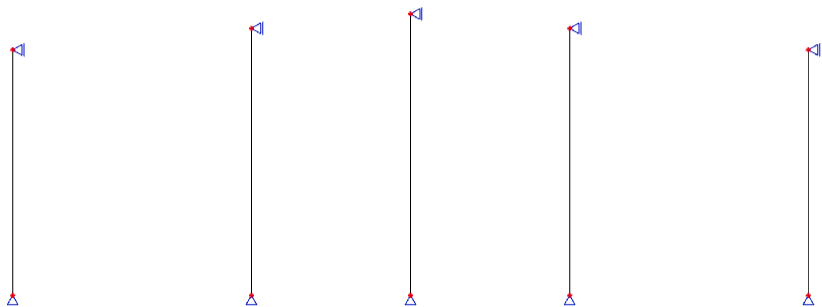

#### 4.1.3. Krovne podrožnice

##### Kombinacije:

$$\text{Kombinacija: } GSN_1 = 1,35 * G + 0,9 * S + 1,5 * W_{\text{pritisak}}$$

$$\text{Kombinacija: } GSN_1 = 1,35 * G + 0,9 * W_{\text{pritisak}} + 1,5 * S$$

$$\text{Kombinacija: } GSN_2 = 1,00 * G + 1,50 * W_{\text{odizanje}}$$

-Stalno opterećenje

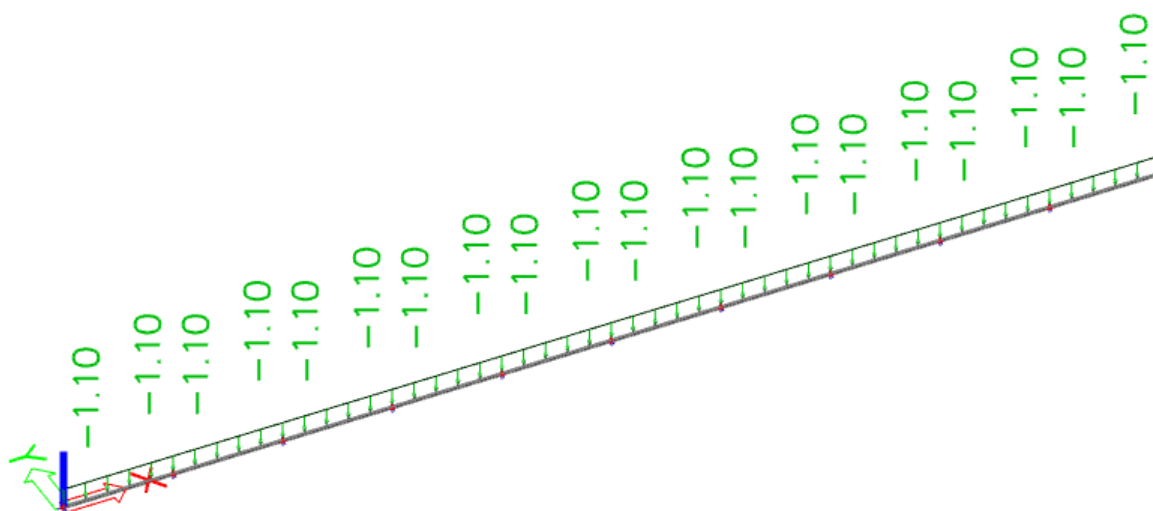

-Snijeg

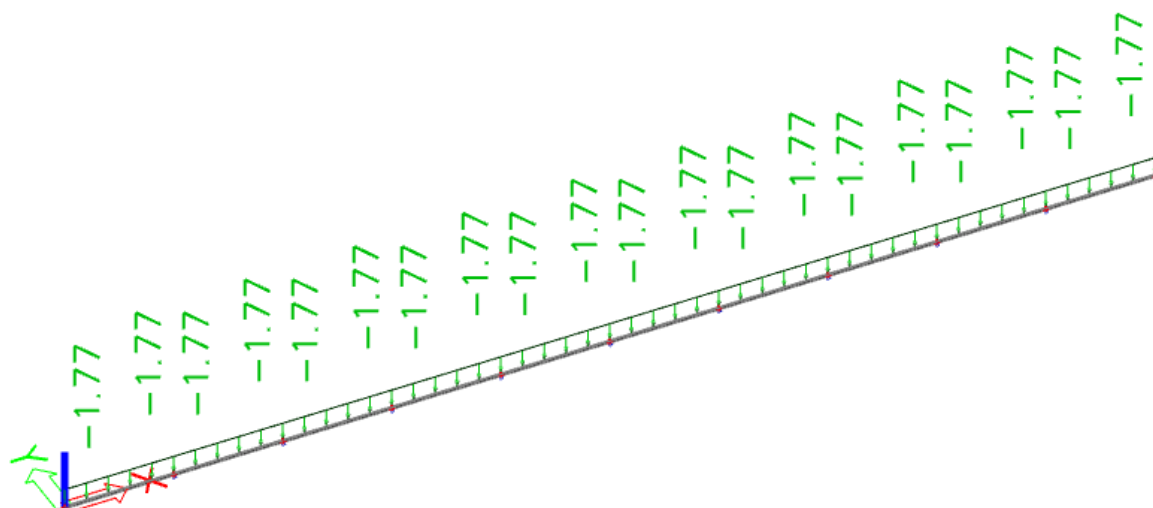

-Pritiskajući vjetar

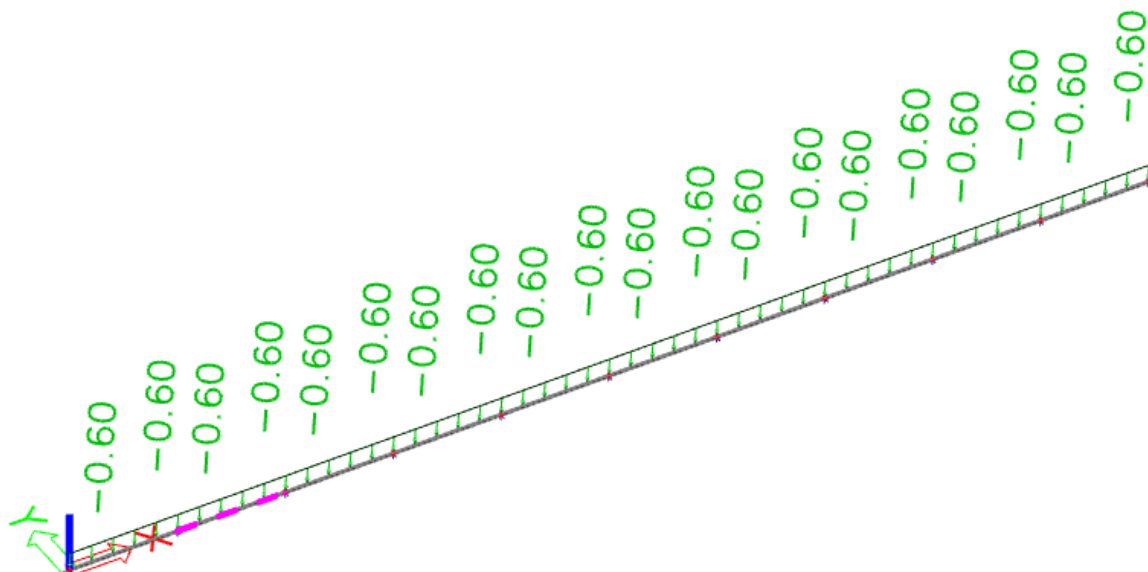

-Odižuci vjetar

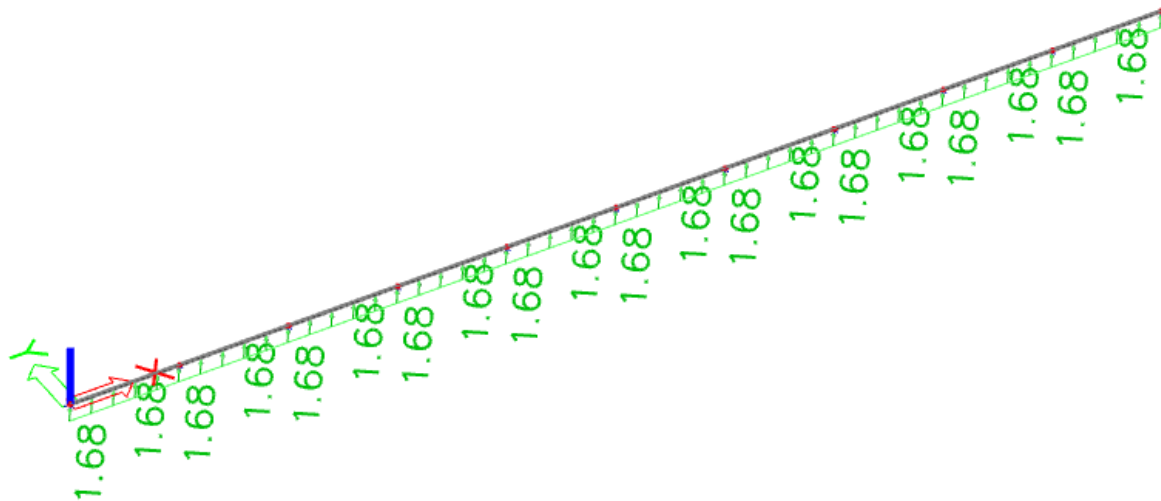



**1D internal forces**

Values:  $M_y$   
 Linear calculation  
 Combination: GSN1  
 Coordinate system: Principal  
 Extreme 1D: Member  
 Selection: All

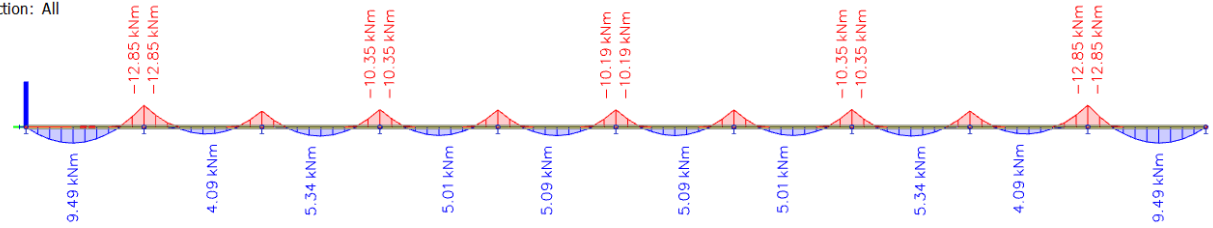

**1D internal forces**

Values:  $V_y$   
 Linear calculation  
 Combination: GSN1  
 Coordinate system: Principal  
 Extreme 1D: Member  
 Selection: All

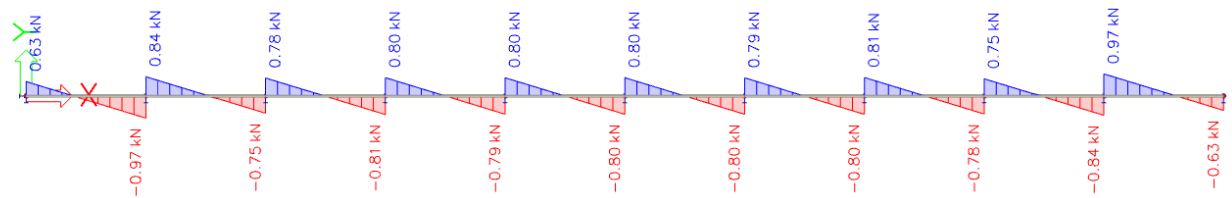

**1D internal forces**

Values:  $M_z$   
 Linear calculation  
 Combination: GSN1  
 Coordinate system: Principal  
 Extreme 1D: Member  
 Selection: All

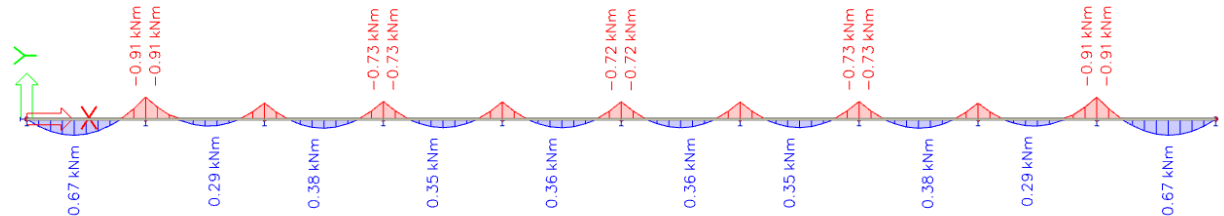

**1D internal forces**

Values:  $V_z$   
 Linear calculation  
 Combination: GSN1  
 Coordinate system: Principal  
 Extreme 1D: Member  
 Selection: All

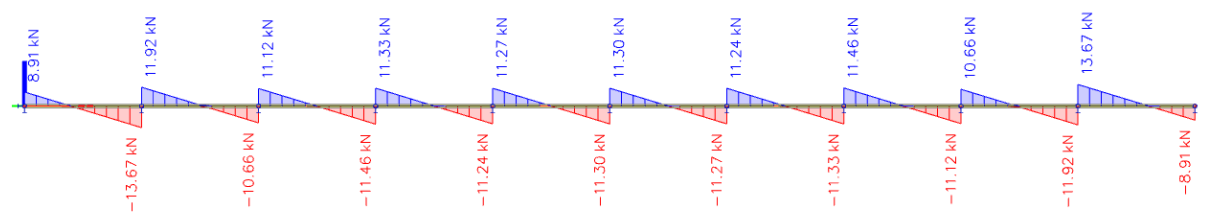

**1D internal forces**

Values:  $M_y$   
 Linear calculation  
 Combination: GSN2  
 Coordinate system: Principal  
 Extreme 1D: Member  
 Selection: All

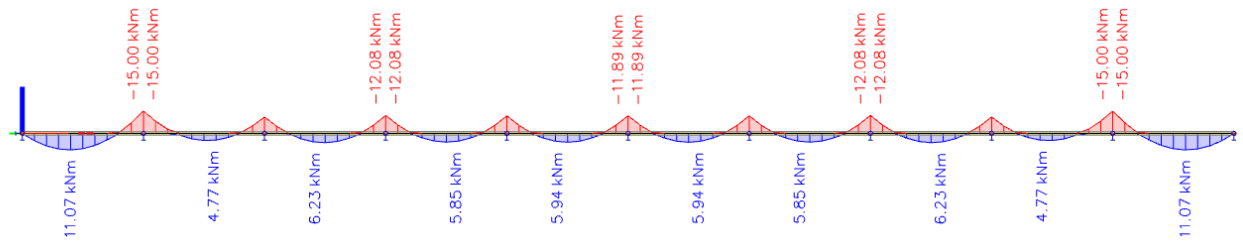

**1D internal forces**

Values:  $V_y$   
 Linear calculation  
 Combination: GSN2  
 Coordinate system: Principal  
 Extreme 1D: Member  
 Selection: All

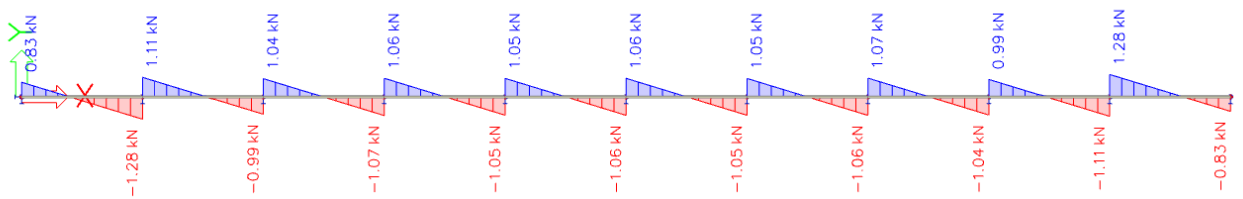

**1D internal forces**

Values:  $M_z$   
 Linear calculation  
 Combination: GSN2  
 Coordinate system: Principal  
 Extreme 1D: Member  
 Selection: All

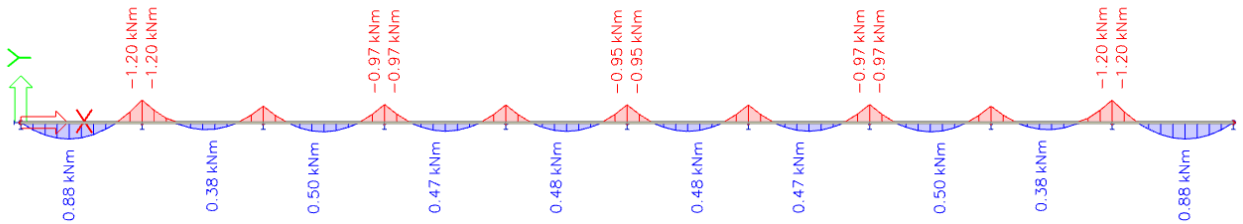

**1D internal forces**

Values:  $V_z$   
 Linear calculation  
 Combination: GSN2  
 Coordinate system: Principal  
 Extreme 1D: Member  
 Selection: All

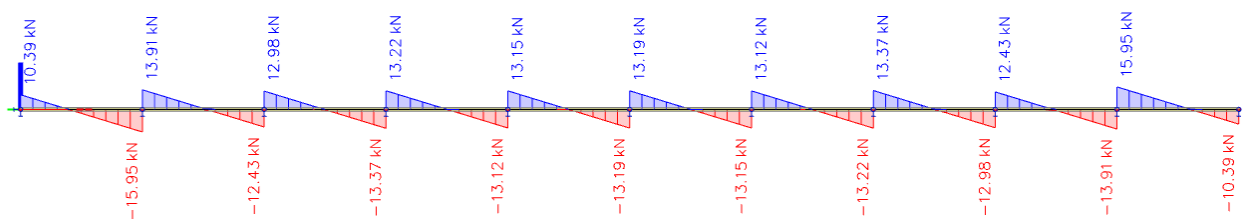

**1D internal forces**

Values:  $M_y$   
 Linear calculation  
 Combination: GSN3  
 Coordinate system: Principal  
 Extreme 1D: Member  
 Selection: All

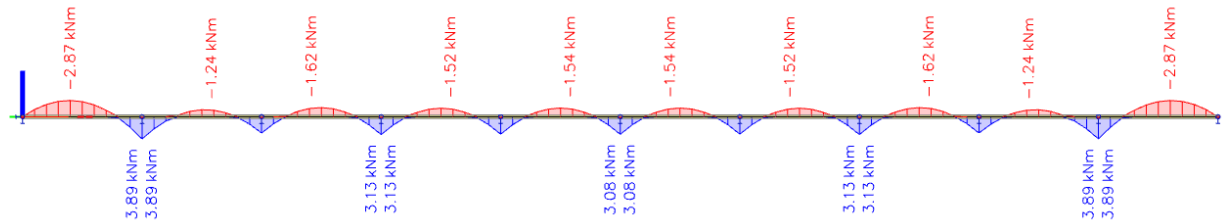

**1D internal forces**

Values:  $V_y$   
 Linear calculation  
 Combination: GSN3  
 Coordinate system: Principal  
 Extreme 1D: Member  
 Selection: All

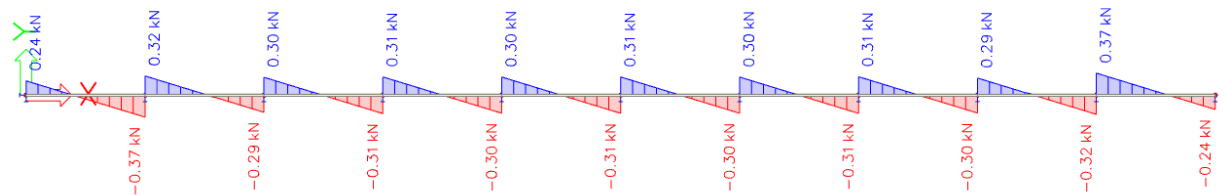

**1D internal forces**

Values:  $M_z$   
 Linear calculation  
 Combination: GSN3  
 Coordinate system: Principal  
 Extreme 1D: Member  
 Selection: All

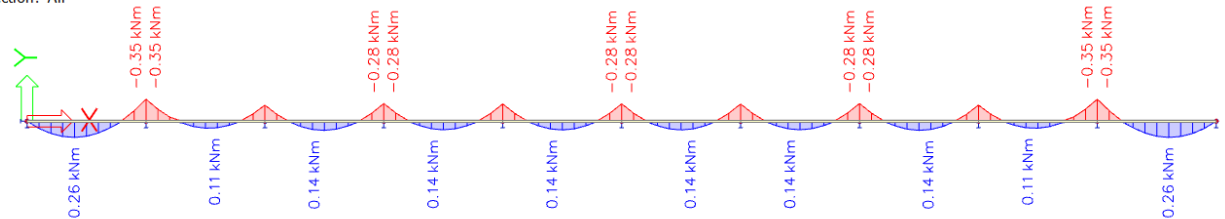

**1D internal forces**

Values:  $V_z$   
 Linear calculation  
 Combination: GSN3  
 Coordinate system: Principal  
 Extreme 1D: Member  
 Selection: All

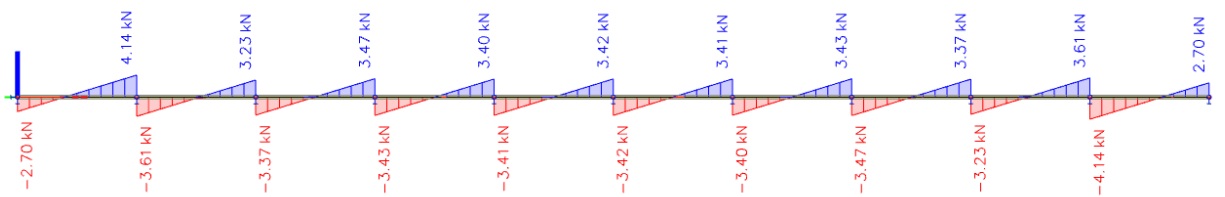

#### 4.1.4. Bočne podrožnice

-Pritiskajući vjetar

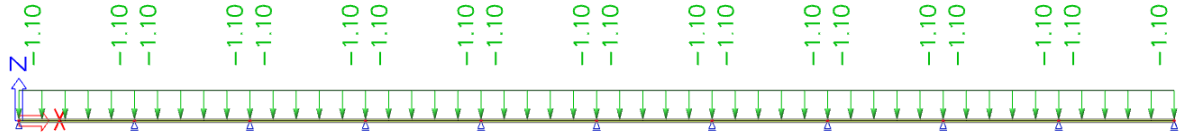

##### 1D internal forces

Values:  $M_y$   
Linear calculation  
Combination: pritiskajući vjetar  
Coordinate system: Member  
Extreme 1D: Global  
Selection: All

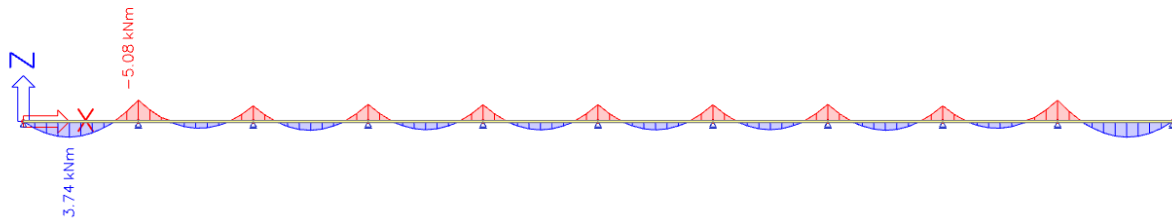

##### 1D internal forces

Values:  $V_z$   
Linear calculation  
Combination: pritiskajući vjetar  
Coordinate system: Member  
Extreme 1D: Global  
Selection: All

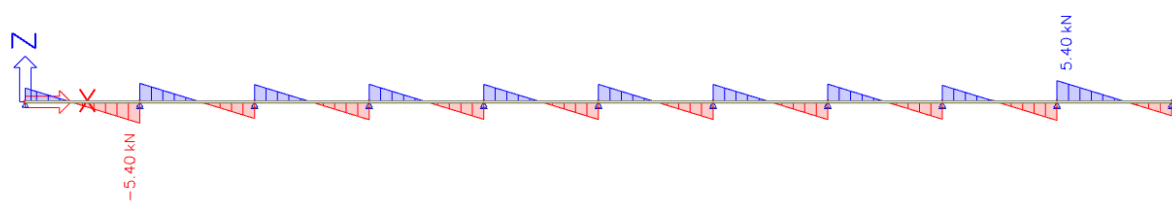

-Odižuci vjetar

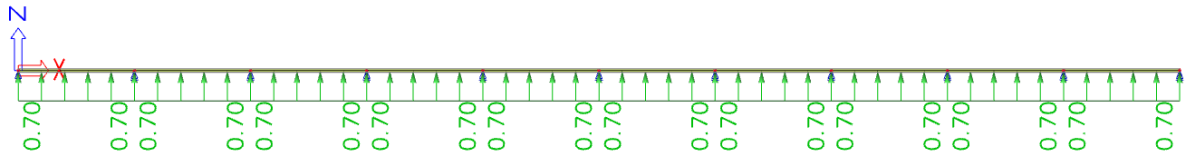

**1D internal forces**

Values:  $M_y$   
Linear calculation  
Combination: odizuci vjetar  
Coordinate system: Member  
Extreme 1D: Global  
Selection: All

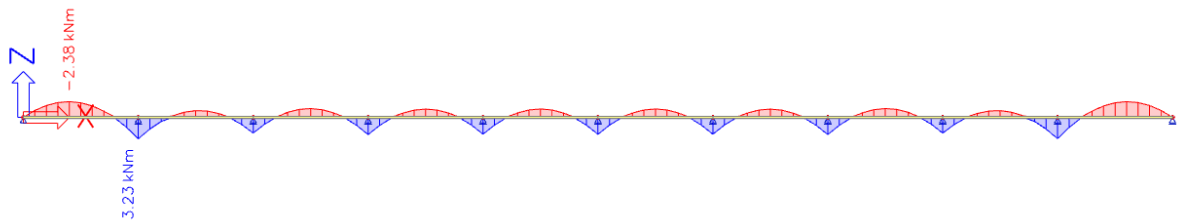

**1D internal forces**

Values:  $V_z$   
Linear calculation  
Combination: odizuci vjetar  
Coordinate system: Member  
Extreme 1D: Global  
Selection: All

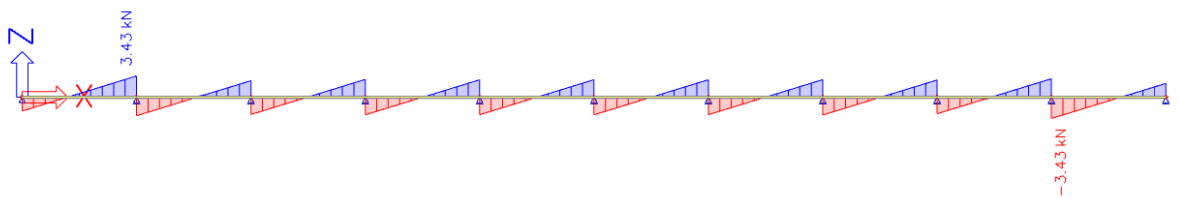

#### 4.1.5. Krovni spreg

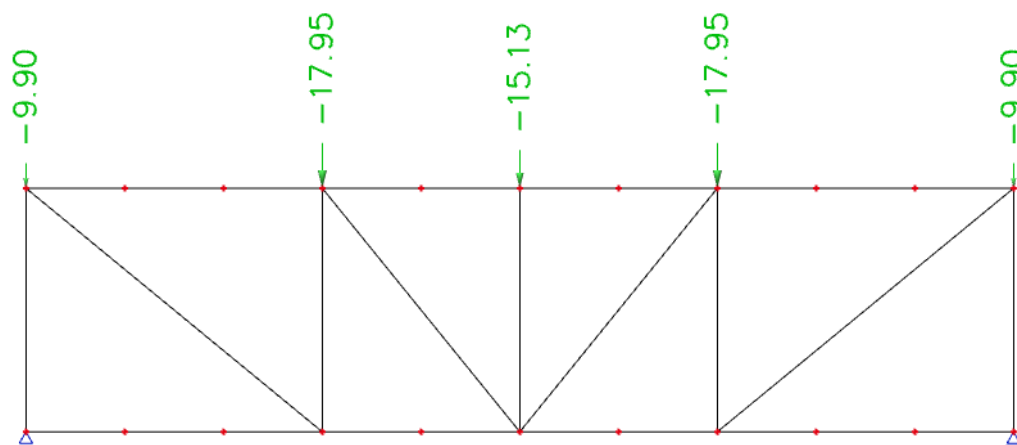
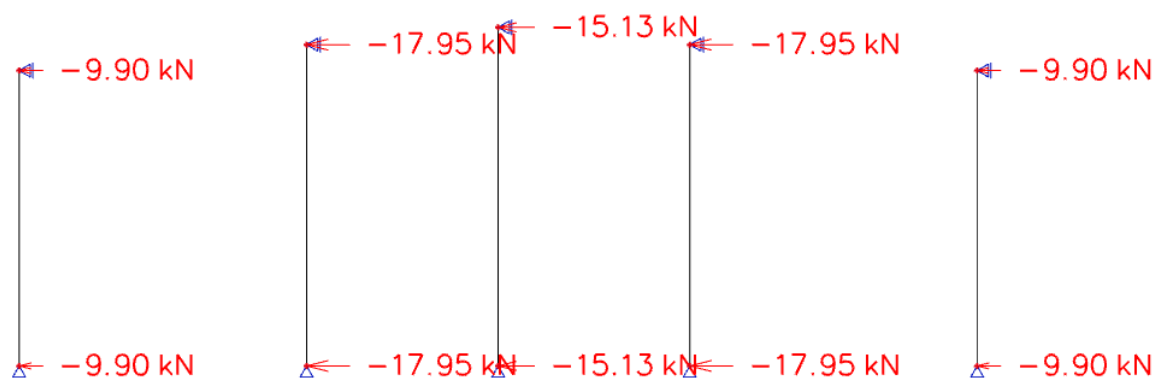

**1D internal forces**

Values:  $M_y$   
 Linear calculation  
 Load case: LC2  
 Coordinate system: Member  
 Extreme 1D: Member  
 Selection: All

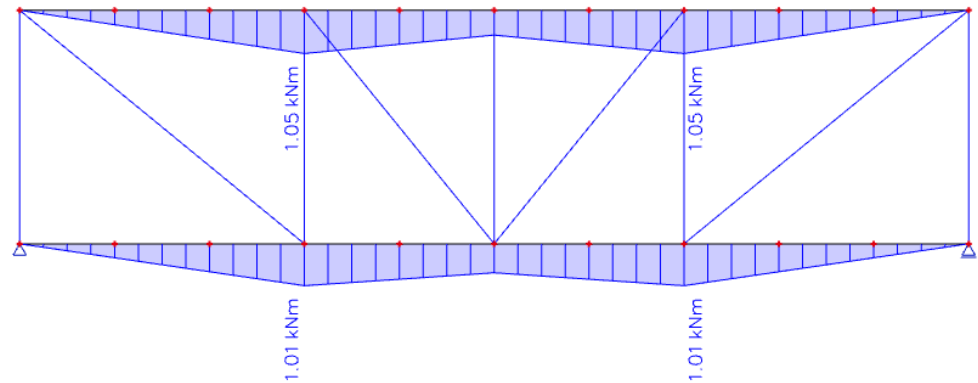

**1D internal forces**

Values:  $V_z$   
 Linear calculation  
 Load case: LC2  
 Coordinate system: Member  
 Extreme 1D: Member  
 Selection: All

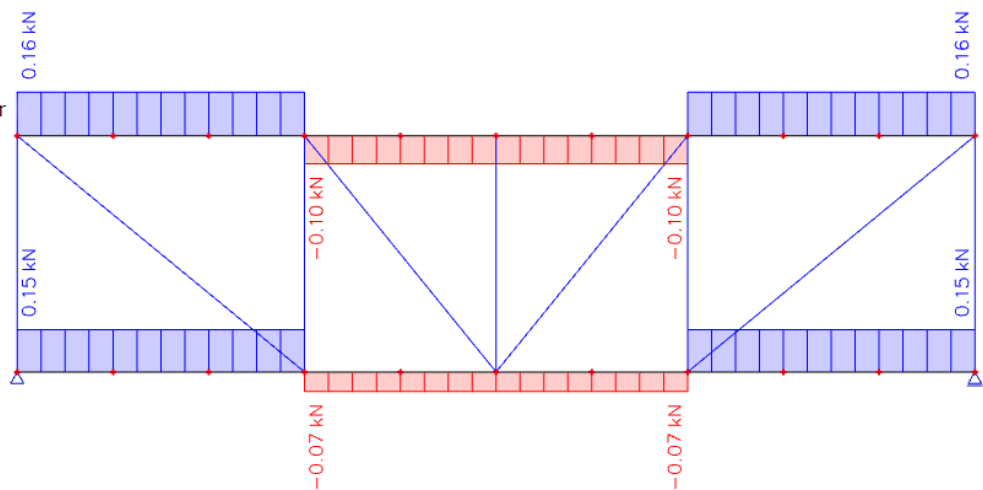

**1D internal forces**

Values:  $N$   
 Linear calculation  
 Load case: LC2  
 Coordinate system: Member  
 Extreme 1D: Member  
 Selection: All

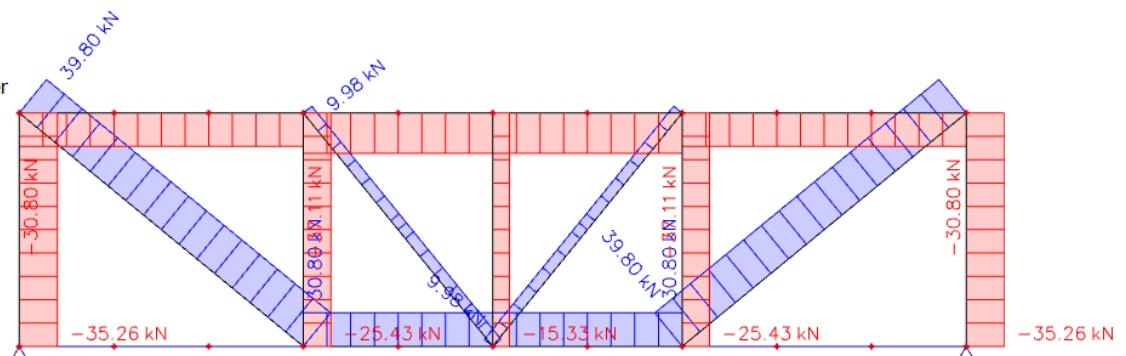

#### 4.1.6. Bočni spreg

##### Reactions

Values:  $R_z$

Linear calculation

Load case: LC2

System: Global

Extreme: Member

Selection: All

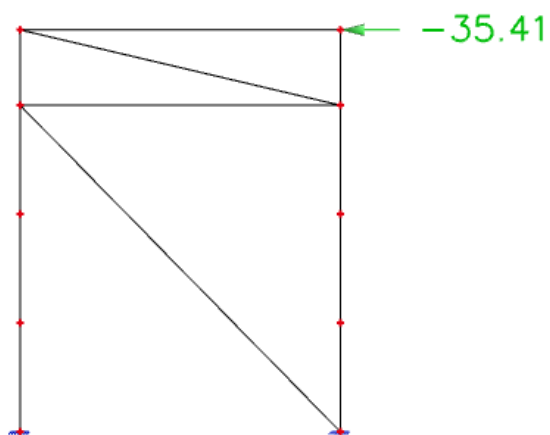
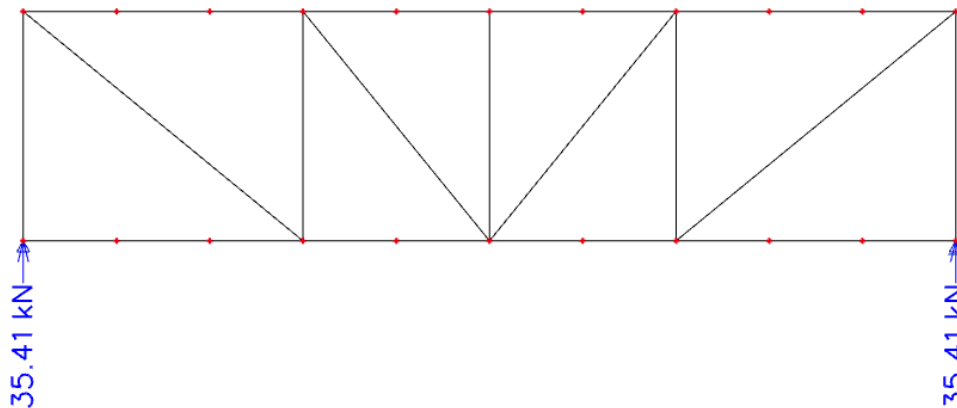

##### 1D internal forces

Values:  $N$

Linear calculation

Load case: krovni reakcija

Coordinate system: Member

Extreme 1D: Global

Selection: All

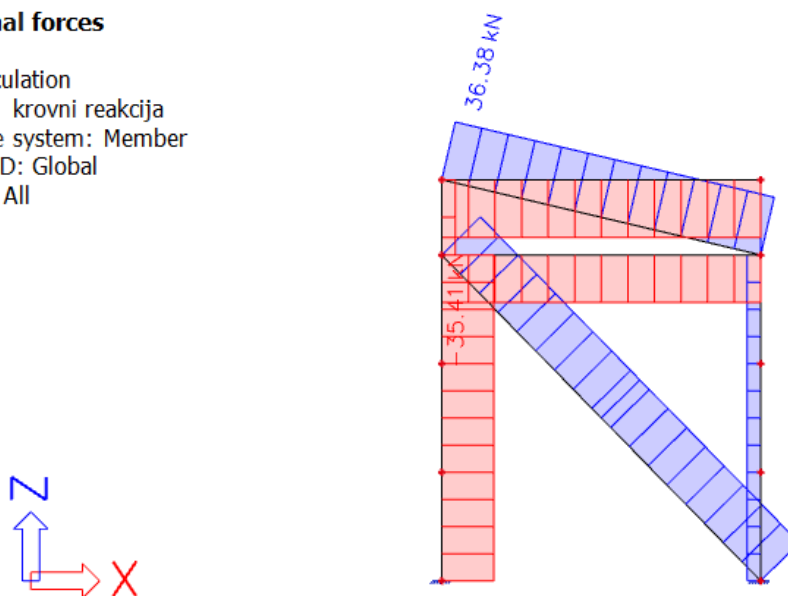



## 5. DIMENZIONIRANJE ELEMENATA KONSTRUKCIJE PREMA GRANIČNOM STANJU NOSIVOSTI

### 5.1. Glavna nosiva konstrukcija

#### 5.1.1. Gornji pojas rešetke

<b>PROFIL:</b>		<b>CFRHS 140x140x7.1</b>	$\epsilon = 0.81$		
<b>KVALITETA ČELIKA:</b>	S 355	$f_y = 35.5 \text{ (kN/cm}^2\text{)}$	$f_u = 49.0 \text{ (kN/cm}^2\text{)}$		
<b>GEOMETRIJSKI PODATCI PROFILA:</b>					
b (cm)	14.0	t (cm)	0.71	$r_o$ (cm)	1.80
h (cm)	14.0	A (cm <sup>2</sup> )	36.01	$r_i$ (cm)	1.10
$W_{pl,Y}$ (cm <sup>3</sup> )	176.27	$I_y$ (cm <sup>4</sup> )	1031.4	$I_w$ (cm <sup>6</sup> )	31821
$W_{pl,Z}$ (cm <sup>3</sup> )	176.27	$I_z$ (cm <sup>4</sup> )	1031.4	$I_T$ (cm <sup>4</sup> )	1718.7
<b>MEHANIČKI PODATCI ČELIKA:</b>					
E (kN/cm <sup>2</sup> )	21000	G (kN/cm <sup>2</sup> )	8077	$\nu$	0.30

#### Rezne sile uslijed kritične kombinacije (GSN 2):

$$M_{Ed} = 0 \text{ (kNm)}$$

$$V_{Ed} = 0 \text{ (kN)}$$

$$N_{Ed} = -328.72 \text{ (kN)}$$

#### Klasifikacija poprečnog presjeka:

- Hrbat (tlak):

$$\frac{d}{t} = \frac{h-3*t}{t} = 17.00$$

$$\text{Uvjet za klasu 1: } \frac{d}{t} \leq 33 \epsilon = 26.73$$

Hrbat je klase 1

Poprečni presjek je klase 1.

#### Otpornost poprečnog presjeka:

- Uzdužna tlačna sila

$$N_{c,Rd} = N_{pl,Rd} = \frac{A \cdot f_y}{\gamma_{M,0}} = \frac{36.01 \cdot 35.5}{1} = 1278.36 \text{ (kN)} \geq N_{Ed} = 328.72 \text{ (kN)}$$

Profil zadovoljava na tlačnu silu s iskoristivosti p.p. od 27.02 %

### Otpornost elementa:

- Tlačna sila:

$$L_i^Z = 6.63 \text{ (m)} = 663 \text{ (cm)}$$

$$L_i^Y = 2.21 \text{ (m)} = 221 \text{ (cm)}$$

$$N_{CR}^Z = \frac{\pi^2 * E * I_z}{L_i^2} = 486.80 \text{ (kN)}$$

$$N_{CR}^Y = \frac{\pi^2 * E * I_y}{L_i^2} = 4381.24 \text{ (kN)}$$

Izvijanje oko osi: Y-Y ili Z-Z

Faktor imperfekcije:  $\alpha=0.49$  ← Linija izvijanja: c ← Hladno oblikovani

$$\lambda^Z = \sqrt{\frac{A * f_y}{N_{CR}^Z}} = 1.62 \rightarrow \text{Očitano za liniju izvijanja c: } \chi^Z = 0.28$$

$$\lambda^Y = \sqrt{\frac{A * f_y}{N_{CR}^Y}} = 0.54 \rightarrow \text{Očitano za liniju izvijanja c: } \chi^Y = 0.82$$

$$N_{B,Rd} = \chi^Z * \frac{A * f_y}{\gamma_{m1}} = 356.02 \text{ (kN)} \geq N_{Ed} = 328.72 \text{ (kN)}$$

Profil CFRHS 140/140/7.1 zadovoljava otpor. elementa s iskoristivosti od 92 %

### 5.1.2. Donji pojas rešetke

<b>PROFIL:</b>		<b>CFRHS 100x100x5</b>	$\epsilon = 0.81$		
<b>KVALITETA ČELIKA:</b>	S355	$f_y = 35.5 \text{ (kN/cm}^2\text{)}$	$f_u = 49.0 \text{ (kN/cm}^2\text{)}$		
<b>GEOMETRIJSKI PODATCI PROFILA:</b>					
b (cm)	10.0	t (cm)	0.5	$r_o$ (cm)	1.0
h (cm)	10.0	A (cm <sup>2</sup> )	18.36	$r_i$ (cm)	0.5
$W_{pl,Y}$ (cm <sup>3</sup> )	64.59	$I_y$ (cm <sup>4</sup> )	271.1	$I_w$ (cm <sup>6</sup> )	4166.7
$W_{pl,Z}$ (cm <sup>3</sup> )	64.59	$I_z$ (cm <sup>4</sup> )	271.1	$I_T$ (cm <sup>4</sup> )	440.52
<b>MEHANIČKI PODATCI ČELIKA:</b>					
E (kN/cm <sup>2</sup> )	21000	G (kN/cm <sup>2</sup> )	8077	$\nu$	0.30

### Rezne sile uslijed kritičnih kombinacija za mjerodavnu dijagonalu:

GSN 2	GSN 2
$M_{Ed} = 0 \text{ (kNm)}$	$M_{Ed} = 0 \text{ (kNm)}$
$V_{Ed} = 0 \text{ (kN)}$	$V_{Ed} = 0 \text{ (kN)}$
$N_{Ed} = -9.44 \text{ (kN)}$	$N_{Ed} = +329.76 \text{ (kN)}$

### Klasifikacija poprečnog presjeka:

- Hrbat:

$$\frac{d}{t} = \frac{h-3*t}{t} = 17.0$$

Uvjet za klasu 1:  $\frac{d}{t} \leq 33 \epsilon = 26.73$

Hrbat je klase 1

Poprečni presjek je klase 1.

### Otpornost poprečnog presjeka:

- Uzdužna vlačna sila

$$N_{t,Rd} = N_{pl,Rd} = \frac{A \cdot f_y}{\gamma_{M,0}} = \frac{18.36 \cdot 35.5}{1} = 651.78 \text{ (kN)} \geq N_{Ed} = 329.76 \text{ (kN)}$$

$$N_{u,Rd} = \frac{0.9 \cdot A \cdot f_u}{\gamma_{M,2}} = \frac{0.9 \cdot 18.36 \cdot 49.0}{1.25} = 647.74 \text{ (kN)} \geq N_{Ed} = 329.76 \text{ (kN)}$$

$$N_{t,Rd} = \min(N_{pl,Rd}, N_{u,Rd}) = \min(651.78, 647.74) = 647.74 \text{ kN}$$

Profil CFRHS 100/100/5 zadovoljava otpor. elementa s iskoristivosti od 50.75 %

- Uzdužna tlačna sila

$$N_{c,Rd} = N_{pl,Rd} = \frac{A \cdot f_y}{\gamma_{M,0}} = \frac{18.36 \cdot 35.5}{1} = 651.78 \text{ (kN)} \geq N_{Ed} = 9.44 \text{ (kN)}$$

Profil zadovoljava na tlačnu silu s iskoristivosti p.p. od 1.45 %

### Otpornost elementa:

- Tlačna sila:

$$L_i^z = 22.0 \text{ (m)} = 2200 \text{ (cm)}$$

$$L_i^y = 2.20 \text{ (m)} = 220 \text{ (cm)}$$

$$N_{CR}^z = \frac{\pi^2 \cdot E \cdot I_z}{L_i^2} = 11.61 \text{ (kN)}$$

$$N_{CR}^y = \frac{\pi^2 \cdot E \cdot I_y}{L_i^2} = 1160.92 \text{ (kN)}$$

Izvijanje oko osi: Y-Y ili Z-Z

Faktor imperfekcije:  $\alpha = 0.49$  ← Linija izvijanja: c ← Hladno oblikovani

$$\lambda^z = \sqrt{\frac{A \cdot f_y}{N_{CR}^z}} = 7.49 \rightarrow \text{Očitano za liniju izvijanja c: } \chi^z = 0.02$$

$$\lambda^y = \sqrt{\frac{A \cdot f_y}{N_{CR}^y}} = 0.75 \rightarrow \text{Očitano za liniju izvijanja c: } \chi^y = 0.69$$

$$N_{b,Rd} = \chi^z \cdot \frac{A \cdot f_y}{\gamma_{m1}} = 10.90 \text{ (kN)} \geq N_{Ed} = 9.44 \text{ (kN)}$$

Profil CFRHS 100/100/5 zadovoljava otpor. elementa s iskoristivosti od 86.61 %

### 5.1.3 Dijagonale rešetke

<b>PROFIL:</b>		<b>CFRHS 80x40x4.0</b>	$\epsilon = 0.81$		
<b>KVALITETA ČELIKA:</b>	S355	$f_y = 35.5 \text{ (kN/cm}^2\text{)}$	$f_u = 49.0 \text{ (kN/cm}^2\text{)}$		
<b>GEOMETRIJSKI PODATCI PROFILA:</b>					
b (cm)	4.0	t (cm)	0.4	$r_o$ (cm)	0.80
h (cm)	8.0	A (cm <sup>2</sup> )	8.55	$r_i$ (cm)	0.40
$W_{pl,Y}$ (cm <sup>3</sup> )	20.91	$I_y$ (cm <sup>4</sup> )	64.79	$I_w$ (cm <sup>6</sup> )	204.08
$W_{pl,Z}$ (cm <sup>3</sup> )	12.77	$I_z$ (cm <sup>4</sup> )	21.49	$I_T$ (cm <sup>4</sup> )	55.24
<b>MEHANIČKI PODATCI ČELIKA:</b>					
E (kN/cm <sup>2</sup> )	21000	G (kN/cm <sup>2</sup> )	8077	$\nu$	0.30

**Rezne sile uslijed kritičnih kombinacija za mjerodavnu dijagonalu:**

<b>GSN 3</b>	<b>GSN 2</b>
$M_{Ed} = 0 \text{ (kNm)}$	$M_{Ed} = 0 \text{ (kNm)}$
$V_{Ed} = 0 \text{ (kN)}$	$V_{Ed} = 0 \text{ (kN)}$
$N_{Ed} = - 3.13 \text{ (kN)}$	$N_{Ed} = + 206.21 \text{ (kN)}$

**Klasifikacija poprečnog presjeka:**

- Hrbat:

$$\frac{d}{t} = \frac{h-3*t}{t} = 9.50$$

Uvjet za klasu 1:  $\frac{d}{t} \leq 33 \epsilon = 26.73$

Hrbat je klase 1

Poprečni presjek je klase 1.

**Otpornost poprečnog presjeka:**

- Uzdužna vlačna sila (GSN 2)

$$N_{pl,Rd} = \frac{A*f_y}{\gamma_{M,0}} = \frac{8.55*35.5}{1} = 303.53 \text{ (kN)} \geq N_{Ed} = 206.21 \text{ (kN)}$$

$$N_{u,Rd} = \frac{0.9*A*f_u}{\gamma_{M,2}} = \frac{0.9*8.55*49.0}{1.25} = 301.64 \text{ (kN)} \geq N_{Ed} = 206.21 \text{ (kN)}$$

$$N_{t,Rd} = \min(N_{pl,Rd}, N_{u,Rd}) = \min(303.53, 301.64) = 301.64 \text{ kN}$$

Profil zadovoljava na vlačnu silu s iskoristivosti p.p. od 68.36 %

- Uzdužna tlačna sila (GSN 3)

$$N_{c,Rd} = N_{pl,Rd} = \frac{A*f_y}{\gamma_{M,0}} = \frac{8.55*35.5}{1} = 303.53 \text{ (kN)} \geq N_{Ed} = 3.13 \text{ (kN)}$$

Profil zadovoljava na tlačnu silu s iskoristivosti p.p. od 1.03 %

### Otpornost elementa:

- Tlačna sila:

$$L_i^2 = 2.54 \text{ (m)} = 2.54 \text{ (cm)}$$

$$N_{CR,z} = \frac{\pi^2 * E * I_z}{L_i^2} = 69.03 \text{ (kN)}$$

Izvijanje oko osi: Z-Z

Faktor imperfekcije:  $\alpha = 0.49$  ← Linija izvijanja: c ← Hladno oblikovani

$$\lambda_z = \sqrt{\frac{A * f_y}{N_{CR,z}}} = 2.10 \rightarrow \text{Očitano za liniju izvijanja c: } \chi_z = 0.18$$

$$N_{B,Rd} = \chi * \frac{A * f_y}{\gamma_{m1}} = 54.87 \text{ (kN)} \geq N_{Ed} = 3.13 \text{ (kN)}$$

Profil CFRHS 80/40/4 zadovoljava otpor. elementa s iskoristivosti od 5.70 %

#### 5.1.4. Vertikale rešetke

<b>PROFIL:</b>		<b>CFRHS 80x40x4.0</b>	$\epsilon = 0.81$		
<b>KVALITETA ČELIKA:</b>	S355	$f_y = 35.5 \text{ (kN/cm}^2\text{)}$	$f_u = 49.0 \text{ (kN/cm}^2\text{)}$		
<b>GEOMETRIJSKI PODATCI PROFILA:</b>					
b (cm)	4.0	t (cm)	0.4	$r_o$ (cm)	0.80
h (cm)	8.0	A (cm <sup>2</sup> )	8.55	$r_i$ (cm)	0.40
$W_{pl,Y}$ (cm <sup>3</sup> )	20.91	$I_y$ (cm <sup>4</sup> )	64.79	$I_w$ (cm <sup>6</sup> )	204.08
$W_{pl,Z}$ (cm <sup>3</sup> )	12.77	$I_z$ (cm <sup>4</sup> )	21.49	$I_T$ (cm <sup>4</sup> )	55.24
<b>MEHANIČKI PODATCI ČELIKA:</b>					
E (kN/cm <sup>2</sup> )	21000	G (kN/cm <sup>2</sup> )	8077	$\nu$	0.30

**Rezne sile uslijed kritične kombinacije (GSN 2) za mjerodavnu vertikalu:**

$$M_{Ed} = 0 \text{ (kNm)}$$

$$V_{Ed} = 0 \text{ (kN)}$$

$$N_{Ed} = -102.84 \text{ (kN)}$$

**Klasifikacija poprečnog presjeka:**

- Hrbat:

$$\frac{d}{t} = \frac{h-3*t}{t} = 9.5$$

$$\text{Uvjet za klasu 1: } \frac{d}{t} \leq 33 \epsilon = 26.73$$

Hrbat je klase 1

Poprečni presjek je klase 1.

**Otpornost poprečnog presjeka:**

- Uzdužna tlačna sila

$$N_{c,Rd} = N_{pl,Rd} = \frac{A * f_y}{\gamma_{M,0}} = \frac{8.55 * 35.5}{1} = 303.53 \text{ (kN)} \geq N_{Ed} = 102.84 \text{ (kN)}$$

Profil zadovoljava na tlačnu silu s iskoristivosti p.p. od 33.88%

### Otpornost elementa:

- Tlačna sila:

$$L_i = 1.47 \text{ (m)} = 147 \text{ (cm)}$$

$$N_{CR} = \frac{\pi^2 * E * I_z}{L_i^2} = 206.68 \text{ (kN)}$$

Izvijanje oko osi: Y-Y ili Z-Z

Faktor imperfekcije:  $\alpha = 0.49$  ← Linija izvijanja: a ← Vruće dogotovljeni

$$\lambda_z = \sqrt{\frac{A * f_y}{N_{CR}}} = 1.21 \rightarrow \text{Očitano za liniju izvijanja a: } \chi_z = 0.43$$

$$N_{B,Rd} = \chi * \frac{A * f_y}{\gamma_{m1}} = 129.96 \text{ (kN)} \geq N_{Ed} = 102.84 \text{ (kN)}$$

Profil CFRHS 80/40/4 zadovoljava otpor. elementa s iskoristivosti od 79.13%



### 5.1.5. Stupovi okvira

<b>PROFIL:</b>		<b>HEA 280</b>		$\epsilon = 0.81$	
<b>KVALITETA ČELIKA:</b>	S355	$f_y = 35.5 \text{ (kN/cm}^2\text{)}$		$f_u = 49.0 \text{ (kN/cm}^2\text{)}$	
<b>GEOMETRIJSKI PODATCI PROFILA:</b>					
b (cm)	28.0	r (cm)	2.4	$t_f$ (cm)	1.3
h (cm)	27.0	A (cm <sup>2</sup> )	97.30	$t_w$ (cm)	0.8
$W_{pl,y}$ (cm <sup>3</sup> )	1112.5	$I_y$ (cm <sup>4</sup> )	13700	$I_w$ (cm <sup>6</sup> )	785370
$W_{pl,z}$ (cm <sup>3</sup> )	516.67	$I_z$ (cm <sup>4</sup> )	4760	$I_T$ (cm <sup>4</sup> )	62.1
<b>MEHANIČKI PODATCI ČELIKA:</b>					
E (kN/cm <sup>2</sup> )	21000	G (kN/cm <sup>2</sup> )	8077	$\nu$	0.30

#### Rezne sile uslijed kritične kombinacije (GSN 2):

$$M_{Ed} = 68.49 \text{ (kNm)}$$

$$V_{Ed} = 14.07 \text{ (kN)}$$

$$N_{Ed} = -119.06 \text{ (kN)}$$

#### Klasifikacija profila:

- Hrbat (savijanje + tlak):

$$a = \frac{N_{Ed}}{2 \cdot t_w \cdot f_y / \gamma_{M0}} = 2.096 \text{ cm}; d = 5.5 \text{ m} = 550 \text{ cm}; \alpha = \frac{1}{d} * \left( \frac{d}{2} + a \right) = 0.504$$

$$\frac{d}{t_w} = \frac{h - 2 \cdot t_f - 2 \cdot r}{t_w} = 24.50$$

$$\text{Uvjet za klasu 1: } \frac{d}{t_w} \leq \frac{396 \cdot \epsilon}{13 \cdot \alpha - 1} = 57.78 \quad \text{Hrbat je klase 1}$$

- Pojasnice (tlak):

$$\frac{c}{t_f} = \frac{0.5 \cdot (b - 2 \cdot r - t_w)}{t_f} = 8.62$$

$$\text{Uvjet za klasu 1: } \frac{c}{t_f} \leq 9 \cdot \epsilon = 8.62 \quad \text{Pojasnice su klase 1}$$

Poprečni presjek je klase 1.

### Otpornost poprečnog presjeka:

- Savijanje:

$$M_{c,Rd} = M_{pl,Rd} = \frac{W_{pl,y} * f_y}{\gamma_{m0}} = \frac{1112.5 * 35.5}{1} = 38958.0 \text{ (kNcm)} = 389.58 \text{ (kNm)}$$

$$M_{c,Rd} = 389.58 \text{ (kNm)} \geq M_{Ed} = 68.49 \text{ (kNm)}$$

Profil zadovoljava na savijanje s iskoristivosti p.p. od 17.57%

- Posmik:

$$\frac{h_w}{t_w} = \frac{h - 2 * t_f}{t_w} = \frac{24.4}{0.8} = 30.5 \leq 72 \frac{\epsilon}{\eta} = 72 \frac{0.81}{1.20} = 69.98$$

Nije potrebna kontrola izbočavanja hrpta uslijed djelovanja posmika!

$$A_{v,z} = A - 2 * b * t_f + (t_w + 2 * r) * t_f = 31.70 \text{ (cm}^2) \geq \eta * h_w * t_w = 23.42 \text{ (cm}^2) \quad \text{Uvjet zadovoljen!}$$

$$V_{Rd}^z = V_{pl,Rd} = \frac{A_{v,z} * f_y}{\sqrt{3} * \gamma_{m0}} = \frac{31.7 * 35.5}{1.7321} = 651.36 \text{ (kN)}$$

$$V_{Rd}^z = 651.36 \text{ (kN)} \geq V_{Ed} = 14.07 \text{ (kN)}$$

Profil zadovoljava na posmik s iskoristivosti p.p. od 2.16%

- Uzdužna tlačna sila

$$N_{c,Rd} = N_{pl,Rd} = \frac{A * f_y}{\gamma_{M,0}} = \frac{97.30 * 35.5}{1} = 3454.15 \text{ (kN)}$$

$$N_{c,Rd} = 3454.15 \text{ (kN)} \geq N_{Ed} = 119.06 \text{ (kN)}$$

Profil zadovoljava na tlačnu silu s iskoristivosti p.p. od 3.43%

- Interakcija M-V-N

$$0.25 * N_{c,Rd} = 863.54 \text{ (kN)} \geq N_{Ed} = 119.06 \text{ (kN)}$$

$$0.5 * V_{z,Rd} = 325.68 \text{ (kN)} \geq V_{Ed} = 14.07 \text{ (kN)}$$

Nema redukcije  $M_{c,Rd}$  uslijed interakcije reznih sila!

### Otpornost elementa:

- Savijanje:

$$L_{CR} = 5.5 \text{ (m)} = 550 \text{ (cm)} \quad z_G = \frac{h}{2} = 13.5 \text{ (cm)}$$

$$k = 1.0 \quad k_w = 1.0 \quad C_1 = 1.88 \quad C_2 = 0.03$$

$$M_{CR} = C_1 * \frac{\pi^2 * E * I_z}{(k * L_{CR})^2} * \left[ \sqrt{\left(\frac{k}{k_w}\right)^2 * \frac{I_w}{I_z} + \frac{(k * L_{CR})^2 * G * I_T}{\pi^2 * E * I_z} + (C_2 * z_g)^2} - C_2 * z_g \right] = 1097.14 \text{ (kNm)}$$

$$\lambda_{LT} = \sqrt{\frac{W_{PLY} * f_y}{M_{CR}}} = 0.60 \geq \lambda_{LT,0} = 0.4 \quad \text{Reduciramo } M_{c,Rd} \text{ zbog mogućnosti instabiliteta elementa.}$$

$$\text{Faktor imperfekcije: } \alpha_{LT} = 0.21 \quad \leftarrow \quad \text{Krivulja izvijanja: } a \begin{cases} \frac{h}{b} = 0.96 \leq 2 \\ \text{Vruće valjani I presjek} \end{cases}$$

$$\Phi_{LT} = 0.5 * (1 + \alpha_{LT}(\lambda_{LT} - 0.2) + \lambda_{LT}^2) = 0.7$$

$$\chi_{LT} = \frac{1}{\Phi_{LT} + \sqrt{\Phi_{LT}^2 - \lambda_{LT}^2}} = 0.99$$

$$M_{B,Rd} = \chi_{LT} * \frac{W_{ply} * f_y}{\gamma_{m1}} = 0.99 * \frac{1112.5 * 35.5}{1} = 38958.0 \text{ (kNcm)} = 389.58 \text{ (kNm)} \geq M_{Ed} = 68.49 \text{ (kNm)}$$

(17.57%)

- Tlačna sila:

$$L_i^Z = 0.7 * 5.5 \text{ (m)} = 3.85 \text{ (m)} = 385 \text{ (cm)}$$

$$L_i^Y = 2 * 5.0 \text{ (m)} = 1100 \text{ (cm)}$$

$$N_{CR}^Z = \frac{\pi^2 * E * I_z}{L_i^2} = 3261.37 \text{ (kN)}$$

$$N_{CR}^Y = \frac{\pi^2 * E * I_y}{L_i^2} = 2341.10 \text{ (kN)}$$

Izvijanje oko osi Z-Z: Faktor imperfekcije:  $\alpha=0.49$  ← Linija izvijanja: c  $\begin{cases} t_f \leq 100 \text{ (mm)} \\ \frac{h}{b} = 0.96 > 1.2 \end{cases}$

Izvijanje oko osi Y-Y: Faktor imperfekcije:  $\alpha=0.34$  ← Linija izvijanja: b  $\begin{cases} t_f \leq 100 \text{ (mm)} \\ \frac{h}{b} = 0.96 > 1.2 \end{cases}$

$$\lambda^Z = \sqrt{\frac{A * f_y}{N_{CR}^Z}} = 1.03 \rightarrow \text{Očitano za liniju izvijanja c: } \chi^Z = 0.52$$

$$\lambda^Y = \sqrt{\frac{A * f_y}{N_{CR}^Y}} = 1.21 \rightarrow \text{Očitano za liniju izvijanja b: } \chi^Y = 0.47$$

$$N_{B,Rd} = \chi^Y * \frac{A * f_y}{\gamma_{m1}} = 1624.23 \text{ (kN)} \geq N_{Ed}^{4.1.1} = 119.06 \text{ (kN)} \text{ (7.28\%)}$$

- Interakcija  $M_b-N_b$  (jednoosno savijanje):

$$C_{MY} = C_{MLT} = 0.95 \quad \leftarrow \quad 0.95 + 0.05 \alpha_h \geq 0.4 \quad \begin{cases} \alpha_h = 0 \\ \psi = 0 \end{cases}$$

$$k_{yy} = C_{MY} \left( 1 + (\chi^Y - 0.2) \frac{N_{Ed}}{\chi^Y * N_{Rd}} \right) \leq C_{MY} \left( 1 + 0.8 \frac{N_{Ed}}{\chi^Y * N_{Rd}} \right) \quad k_{yy} = 1.04$$

$$k_{zy} = 0.6 + \lambda^Z \leq \left( 1 - \frac{0.1 \lambda^Z}{C_{MLT}} * \frac{N_{Ed} * \gamma_{m1}}{\chi^Y * N_{Rk}} \right) \quad k_{zy} = 0.56$$

$$\frac{N_{Ed} * \gamma_{m1}}{\chi^Y * N_{Rk}} + k_{yy} \frac{M_{Ed}^Y * \gamma_{m1}}{\chi^{LT} * M_{Rk}^Y} = 0.0728 + 0.1827 = 0.2555$$

Profil HE 280 A zadovoljava otpornost elementa s iskoristivosti od 25.55 %

## 5.2. Sekundarna nosiva konstrukcija

### 5.2.1. Zabatni stupovi

<b>PROFIL:</b>		<b>HEA 160 A</b>		$\epsilon = 0.81$	
<b>KVALITETA ČELIKA:</b>	S355	$f_y = 35.5 \text{ (kN/cm}^2\text{)}$		$f_u = 49.0 \text{ (kN/cm}^2\text{)}$	
<b>GEOMETRIJSKI PODATCI PROFILA:</b>					
b (cm)	16.0	r (cm)	1.5	$t_f$ (cm)	0.7
h (cm)	14.8	A (cm <sup>2</sup> )	30.40	$t_w$ (cm)	0.5
$W_{El,Y}$ (cm <sup>3</sup> )	185.99	$I_y$ (cm <sup>4</sup> )	1280	$I_w$ (cm <sup>6</sup> )	23751
$W_{pl,Y}$ (cm <sup>3</sup> )	190.42	$I_z$ (cm <sup>4</sup> )	479	$I_T$ (cm <sup>4</sup> )	6.33
<b>MEHANIČKI PODATCI ČELIKA:</b>					
E (kN/cm <sup>2</sup> )	21000	G (kN/cm <sup>2</sup> )	8077	$\nu$	0.30

### Rezne sile uslijed kritične kombinacije (GSN 4.1.2.) za mjerodavni zabatni stup:

$$M_{Ed} = 33.05 \text{ (kNm)}$$

$$V_{Ed} = 17.95 \text{ (kN)}$$

$$N_{Ed} = 0 \text{ (kN)} \rightarrow \text{zanemarena vlastita težina}$$

### Klasifikacija profila:

- Hrbat (savijanje):

$$\frac{d}{t_w} = \frac{h - 2 \cdot t_f - 2 \cdot r}{t_w} = 20.8$$

$$\text{Uvjet za klasu 1: } \frac{d}{t_w} \leq 72 \epsilon = 58.32$$

Hrbat je klase 1

- Pojasnice (tlak):

$$\frac{c}{t_f} = \frac{0.5 \cdot (b - 2 \cdot r - t_w)}{t_f} = 8.92$$

$$\text{Uvjet za klasu 3: } \frac{c}{t_f} \leq 14 \epsilon = 11.34$$

Pojasnice su klase 3

Poprečni presjek je klase 3.

### Otpornost poprečnog presjeka:

- Savijanje:

$$M_{c,Rd} = M_{pl,Rd} = \frac{W_{El,y} \cdot f_y}{\gamma_{m0}} = \frac{185.99 \cdot 35.5}{1} = 66.02 \text{ (kNm)}$$

$$M_{c,Rd} = 66.02 \text{ (kNm)} \geq M_{Ed} = 33.05 \text{ (kNm)}$$

Profil zadovoljava na savijanje s iskoristivosti p.p. od 50.06%

- Posmik:

$$\frac{h_w}{t_w} = \frac{h-2*t_f}{t_w} = 26.8 \leq 72 \frac{\epsilon}{\eta} = 72 \frac{0.81}{1.20} = 48.60$$

Nije potrebna kontrola izbočavanja hrpta uslijed djelovanja posmika!

$$A_{v,z} = A - 2*b*t_f + (t_w+2*r)*t_f = 10.45 \text{ (cm}^2) \geq \eta * h_w * t_w = 9.18 \text{ (cm}^2) \quad \text{Uvjet zadovoljen!}$$

$$V_{Rd}^z = V_{pl,Rd} = \frac{A_{v,z}*f_y}{\sqrt{3}*\gamma_{m0}} = \frac{10.45*35.5}{1.7321} = 214.18 \text{ (kN)}$$

$$V_{Rd}^z = 214.18 \text{ (kN)} \geq V_{Ed} = 17.95 \text{ (kN)}$$

Profil zadovoljava na posmik s iskoristivosti p.p. od 8.38%

- Interakcija M-V-N:

$$N_{Ed} = 0 \text{ (kN)}$$

$$0.5*V_{z,Rd} = 107.09 \text{ (kN)} \geq V_{Ed} = 17.09 \text{ (kN)}$$

Nema redukcije  $M_{c,Rd}$  uslijed interakcije reznih sila!

### Otpornost elementa:

- Savijanje:

$$L_{CR} = 7.364 \text{ (m)} \approx 700 \text{ (cm)} \quad z_G = \frac{h}{2} = 9.5 \text{ (cm)}$$

$$k = 1.0 \quad C_1 = 1.127$$

$$k_w = 1.0 \quad C_2 = 0.454$$

$$M_{CR} = C_1 * \frac{\pi^2 * E * I_z}{(k * L_{CR})^2} * \left[ \sqrt{\left(\frac{k}{k_w}\right)^2 * \frac{I_w}{I_z} + \frac{(k * L_{CR})^2 * G * I_T}{\pi^2 * E * I_z} + (C_2 * z_G)^2} - C_2 * z_G \right] = 37.42 \text{ (kNm)}$$

$$\lambda_{LT} = \sqrt{\frac{W_{ELY} * f_y}{M_{CR}}} = 1.33 \geq \lambda_{LT,0} = 0.4 \quad \text{Reduciramo } M_{c,Rd} \text{ zbog mogućnosti instabiliteta elementa.}$$

$$\text{Faktor imperfekcije: } \alpha_{LT} = 0.34 \quad \leftarrow \quad \text{Krivulja izvijanja : } b \quad \begin{cases} \frac{h}{b} = 1.08 \leq 2 \\ \text{Vruće valjani I presjek} \end{cases}$$

$$\Phi_{LT} = 0.5 * (1 + \alpha_{LT}(\lambda_{LT} - 0.2) + \lambda_{LT}^2) = 1.58$$

$$\chi_{LT} = \frac{1}{\Phi_{LT} + \sqrt{\Phi_{LT}^2 - \lambda_{LT}^2}} = 0.51$$

$$M_{B,Rd} = \chi_{LT} * \frac{W_{pl,y} * f_y}{\gamma_{m1}} = 0.51 * \frac{185.99 * 35.5}{1} = 34.02 \text{ (kNm)} \geq M_{Ed} = 33.05 \text{ (kNm)}$$

Profil HEA 160 A zadovoljava otpornost elementa s iskoristivosti od 97.14%

### 5.2.2. Krovni spregovi (zatege)

<b>PROFIL:</b>		<b>RD 14</b>		$\epsilon = 0.81$	
<b>KVALITETA ČELIKA:</b>	S355	$f_y = 35.5 \text{ (kN/cm}^2\text{)}$		$f_u = 49.0 \text{ (kN/cm}^2\text{)}$	
<b>GEOMETRIJSKI PODATCI PROFILA:</b>					
d (cm)	1.4	r (cm)	0.7	A (cm <sup>2</sup> )	1.54
<b>MEHANIČKI PODATCI ČELIKA:</b>					
E (kN/cm <sup>2</sup> )	21000	G (kN/cm <sup>2</sup> )	8077	v	0.30

#### Rezne sile uslijed kritične kombinacije:

$$M_{Ed} = 0 \text{ (kNm)}$$

$$V_{Ed} = 0 \text{ (kN)}$$

$$N_{Ed} = +39.80 \text{ (kN)}$$

#### Otpornost poprečnog presjeka:

Vlačna sila:

$$N_{pl,Rd} = \frac{A \cdot f_y}{\gamma_{M,0}} = \frac{1.54 \cdot 35.5}{1} = 54.62 \text{ (kN)} \geq N_{Ed} = 39.80 \text{ (kN)}$$

$$N_{u,Rd} = \frac{0.9 \cdot A \cdot f_u}{\gamma_{M,2}} = \frac{0.9 \cdot 1.54 \cdot 49.0}{1.25} = 54.28 \text{ (kN)} \geq N_{Ed} = 39.80 \text{ (kN)}$$

$$N_{t,Rd} = \min(N_{pl,Rd}, N_{u,Rd}) = \min(54.62, 54.28) = 54.28 \text{ kN}$$

Profil zadovoljava na vlačnu silu s iskoristivosti p.p. od 73.32 %

### 5.2.3. Bočni spregovi (zatege)

<b>PROFIL:</b>		<b>RD 14</b>		$\epsilon = 0.81$	
<b>KVALITETA ČELIKA:</b>	S355	$f_y = 35.5 \text{ (kN/cm}^2\text{)}$		$f_u = 49.0 \text{ (kN/cm}^2\text{)}$	
<b>GEOMETRIJSKI PODATCI PROFILA:</b>					
d (cm)	1.4	r (cm)	0.7	A (cm <sup>2</sup> )	1.54
<b>MEHANIČKI PODATCI ČELIKA:</b>					
E (kN/cm <sup>2</sup> )	21000	G (kN/cm <sup>2</sup> )	8077	v	0.30

#### Rezne sile uslijed kritične kombinacije:

$$M_{Ed} = 0 \text{ (kNm)}$$

$$V_{Ed} = 0 \text{ (kN)}$$

$$N_{Ed} = +36.38 \text{ (kN)}$$

#### Otpornost poprečnog presjeka:

Vlačna sila:

$$N_{pl,Rd} = \frac{A \cdot f_y}{\gamma_{M,0}} = \frac{1.54 \cdot 35.5}{1} = 54.62 \text{ (kN)} \geq N_{Ed} = 36.38 \text{ (kN)}$$

$$N_{u,Rd} = \frac{0.9 \cdot A \cdot f_u}{\gamma_{M,2}} = \frac{0.9 \cdot 1.54 \cdot 49.0}{1.25} = 54.28 \text{ (kN)} \geq N_{Ed} = 36.38 \text{ (kN)}$$

$$N_{t,Rd} = \min(N_{pl,Rd}, N_{u,Rd}) = \min(54.62, 54.28) = 54.28 \text{ kN}$$

Profil zadovoljava na vlačnu silu s iskoristivosti p.p. od 67.02 %



### 5.2.4. Krovne podrožnice

<b>PROFIL:</b>		<b>IPE 160</b>		$\epsilon = 0.81$	
<b>KVALITETA ČELIKA:</b>	S355	$f_y = 35.5 \text{ (kN/cm}^2\text{)}$		$f_u = 49.0 \text{ (kN/cm}^2\text{)}$	
<b>GEOMETRIJSKI PODATCI PROFILA:</b>					
b (cm)	8.2	r (cm)	0.9	$t_f$ (cm)	0.7
h (cm)	16.0	A (cm <sup>2</sup> )	20.1	$t_w$ (cm)	0.5
$W_{El,Y}$ (cm <sup>3</sup> )	109.0	$I_y$ (cm <sup>4</sup> )	869	$I_w$ (cm <sup>6</sup> )	3960
$W_{Pl,Y}$ (cm <sup>3</sup> )	124.0	$I_z$ (cm <sup>4</sup> )	68.3	$I_T$ (cm <sup>4</sup> )	3.6
$W_{El,Z}$ (cm <sup>3</sup> )	16.70	$A_{v,Z}$ (cm <sup>2</sup> )	8.12		
$W_{Pl,Z}$ (cm <sup>3</sup> )	26.1	$A_{v,Y}$ (cm <sup>2</sup> )	12.61		
<b>MEHANIČKI PODATCI ČELIKA:</b>					
E (kN/cm <sup>2</sup> )	21000	G (kN/cm <sup>2</sup> )	8077	$\nu$	0.30

#### Rezne sile uslijed kritične kombinacije (GSN 4.1.3.):

Y-Y	Z-Z
$M_{Ed,Y} = 15.00 \text{ (kNm)}$	$M_{Ed,Z} = 1.20 \text{ (kNm)}$
$V_{Ed,Y} = 1.28 \text{ (kN)}$	$V_{Ed,Z} = 15.95 \text{ (kN)}$

#### Klasifikacija profila:

- Hrnat (savijanje):

$$\frac{d}{t_w} = \frac{h - 2 \cdot t_f - 2 \cdot r}{t_w} = 25.6$$

Uvjet za klasu 1:  $\frac{d}{t_w} \leq 72 \epsilon = 58.32$

Hrnat je klase 1

- Pojasnice (tlak):

$$\frac{c}{t_f} = \frac{0.5 \cdot (b - 2 \cdot r - t_w)}{t_f} = 4.21$$

Uvjet za klasu 1:  $\frac{c}{t_f} \leq 9 \epsilon = 7.29$

Pojasnice su klase 1

Poprečni presjek je klase 1.

### Otpornost poprečnog presjeka:

- Savijanje (Y-Y):

$$M_{c,Rd}^Y = M_{pl,Rd} = \frac{W_{pl,y} * f_y}{\gamma_{m0}} = \frac{124. * 35.5}{1} = 4402 \text{ (kNcm)} = 44.02 \text{ (kNm)}$$

$$M_{c,Rd}^Y = 44.02 \text{ (kNm)} \geq M_{Ed}^Y = 15.00 \text{ (kNm)} \quad (34.08\%)$$

- Savijanje (Z-Z):

$$M_{c,Rd}^Z = M_{pl,Rd} = \frac{W_{pl,z} * f_y}{\gamma_{m0}} = \frac{26.1 * 35.5}{1} = 926.55 \text{ (kNcm)} = 9.27 \text{ (kNm)}$$

$$M_{c,Rd}^Z = 9.27 \text{ (kNm)} \geq M_{Ed}^Z = 1.20 \text{ (kNm)} \quad (12.94 \%)$$

Profil zadovoljava na jednoosno savijanje s iskoristivosti p.p. od 34.08 %

- Posmik (Z)

$$\frac{h_w}{t_w} = \frac{h - 2 * t_f}{t_w} = 29.2 \leq 72 \frac{\epsilon}{\eta} = 72 \frac{0.81}{1.20} = 48.6$$

Nije potrebna kontrola izbočavanja hrpta uslijed djelovanja posmika!

$$A_{v,Z} = A - 2 * b * t_f + (t_w + 2 * r) * t_f = 10.23 \text{ (cm}^2) \geq \eta * h_w * t_w = 8.76 \text{ (cm}^2) \quad \text{Uvjet zadovoljen!}$$

$$V_{Rd}^Z = V_{pl,Rd} = \frac{A_{v,z} * f_y}{\sqrt{3} * \gamma_{m0}} = \frac{10.23 * 35.5}{1.7321} = 209.67 \text{ (kN)}$$

$$V_{Rd}^Z = 209.67 \text{ (kN)} \geq V_{Ed}^Z = 15.95 \text{ (kN)} \quad (7.61 \%)$$

- Posmik (Y)

$$\frac{h_w}{t_w} = \frac{h - 2 * t_f}{t_w} = 29.2 \leq 72 \frac{\epsilon}{\eta} = 72 \frac{0.81}{1.20} = 48.6$$

Nije potrebna kontrola izbočavanja hrpta uslijed djelovanja posmika!

$$A_{v,Y} = 2 * b * t_f = 11.48 \text{ (cm}^2) \geq \eta * h_w * t_w = 8.76 \text{ (cm}^2) \quad \text{Uvjet zadovoljen!}$$

$$V_{Rd}^Y = V_{pl,Rd} = \frac{A_{v,y} * f_y}{\sqrt{3} * \gamma_{m0}} = \frac{11.48 * 35.5}{1.7321} = 235.29 \text{ (kN)}$$

$$V_{Rd}^Y = 235.92 \text{ (kN)} \geq V_{Ed}^Y = 1.28 \text{ (kN)} \quad (0,01 \%)$$

Profil zadovoljava na posmik s iskoristivosti p.p. od 7.61 %

- Interakcija M-V-N:

Nema redukcije  $M_{c,Rd}$  uslijed interakcije reznih sila!

### Otpornost elementa:

- Savijanje:

$$L_{CR} = 5.40 \text{ (m)} = 540 \text{ (cm)} \quad z_G = \frac{h}{2} = 8.0 \text{ (cm)}$$

$$k = 1.0 \quad C_1 = 1.66$$

$$k_w = 1.0 \quad C_2 = 0.78$$

$$M_{CR} = C_1 * \frac{\pi^2 * E * I_z}{(k * L_{CR})^2} * \left[ \sqrt{\left(\frac{k}{k_w}\right)^2 * \frac{I_w}{I_z} + \frac{(k * L_{CR})^2 * G * I_T}{\pi^2 * E * I_z}} + (C_2 * z_g)^2 - C_2 * z_g \right] = 20.68 \text{ (kNm)}$$

$$\lambda_{LT} = \sqrt{\frac{W_{PLY} * f_y}{M_{CR}}} = 1.46 \geq \lambda_{LT,0} = 0.4 \quad \text{Reduciramo } M_{c,Rd} \text{ zbog mogućnosti instabiliteta elementa.}$$

$$\text{Faktor imperfekcije: } \alpha_{LT} = 0.34 \quad \leftarrow \quad \text{Krivulja izvijanja : } ab \begin{cases} \frac{h}{b} = 1.8 \leq 2 \\ \text{Vruće valjani I presjek} \end{cases}$$

$$\Phi_{LT} = 0.5 * (1 + \alpha_{LT}(\lambda_{LT} - 0.2) + \lambda_{LT}^2) = 1.78$$

$$\chi_{LT} = \frac{1}{\Phi_{LT} + \sqrt{\Phi_{LT}^2 - \lambda_{LT}^2}} = 0.45$$

$$M_{B,Rd} = \chi_{LT} * \frac{W_{ply} * f_y}{\gamma_{m1}} = 19.89 \text{ (kNm)} \geq M_{Ed}^Y = 15.00 \text{ (kNm)} \quad (75,41\%)$$

- Interakcija  $M_b$ - $V$ - $N_b$  (dvoosno savijanje):

$$C_{My} = C_{Mz} = C_{MLT} = 1.00 \quad \leftarrow \quad 1.00 + 0.05 \alpha_s \geq 0.4 \quad \begin{cases} \alpha_s = 0 \\ \psi = 0 \end{cases}$$

$$k_{yy} = 1.02$$

$$k_{zz} = 1.00$$

$$k_{yz} = 0.83$$

$$k_{zy} = 0.52$$

$$\frac{N_{Ed} * \gamma_{m1}}{\chi^Y * N_{Rk}} + k_{yy} \frac{M_{Ed}^Y * \gamma_{m1}}{\chi^{LT} * M_{Rk}^Y} + k_{yz} \frac{M_{Ed}^Y * \gamma_{m1}}{M_{Rk}^Z} = 0.88$$

$$\frac{N_{Ed} * \gamma_{m1}}{\chi^Z * N_{Rk}} + k_{zy} \frac{M_{Ed}^Y * \gamma_{m1}}{\chi^{LT} * M_{Rk}^Y} + k_{zz} \frac{M_{Ed}^Y * \gamma_{m1}}{M_{Rk}^Z} = 0.52$$

Profil IPE 160 zadovoljava otpornost elementa s iskoristivosti od 88.00 %

### 5.2.5. Bočne podrožnice

<b>PROFIL:</b>		<b>IPE 100</b>		$\epsilon = 0.81$	
<b>KVALITETA ČELIKA:</b>	S355	$f_y = 35.5 \text{ (kN/cm}^2\text{)}$		$f_u = 49.0 \text{ (kN/cm}^2\text{)}$	
<b>GEOMETRIJSKI PODATCI PROFILA:</b>					
b (cm)	5.5	r (cm)	0.7	$t_f$ (cm)	0.6
h (cm)	10.0	A (cm <sup>2</sup> )	10.30	$t_w$ (cm)	0.4
$W_{El,Y}$ (cm <sup>3</sup> )	34.2	$I_y$ (cm <sup>4</sup> )	171.0	$I_w$ (cm <sup>6</sup> )	350
$W_{Pl,Y}$ (cm <sup>3</sup> )	39.4	$I_z$ (cm <sup>4</sup> )	15.90	$I_T$ (cm <sup>4</sup> )	1.20
$W_{El,Z}$ (cm <sup>3</sup> )	5.79	$A_{v,Z}$ (cm <sup>2</sup> )	4.20		
$W_{Pl,Z}$ (cm <sup>3</sup> )	9.20	$A_{v,Y}$ (cm <sup>2</sup> )	6.74		
<b>MEHANIČKI PODATCI ČELIKA:</b>					
E (kN/cm <sup>2</sup> )	21000	G (kN/cm <sup>2</sup> )	8077	$\nu$	0.30

#### Rezne sile uslijed kritične kombinacije:

$$M_{Ed} = 5.08 \text{ (kNm)}$$

$$V_{Ed} = 5.40 \text{ (kN)}$$

$$N_{Ed} = 0 \text{ (kN)}$$

#### Klasifikacija profila:

- Hrbat (savijanje):

$$\frac{d}{t_w} = \frac{h - 2 \cdot t_f - 2 \cdot r}{t_w} = 18.5$$

$$\text{Uvjet za klasu 1: } \frac{d}{t_w} \leq 72 \epsilon = 58.32 \quad \text{Hrbat je klase 1}$$

- Pojasnice (tlak):

$$\frac{c}{t_f} = \frac{0.5 \cdot (b - 2 \cdot r - t_w)}{t_f} = 3.08$$

$$\text{Uvjet za klasu 1: } \frac{c}{t_f} \leq 9 \epsilon = 7.29 \quad \text{Pojasnice su klase 1}$$

Poprečni presjek je klase 1.

#### Otpornost poprečnog presjeka:

- Savijanje:

$$M_{c,Rd} = M_{pl,Rd} = \frac{W_{pl,y} \cdot f_y}{\gamma_{m0}} = \frac{39.4 \cdot 35.5}{1} = 13.99 \text{ (kNm)}$$

$$M_{c,Rd} = 13.99 \text{ (kNm)} \geq M_{Ed} = 5.08 \text{ (kNm)}$$

Profil zadovoljava na savijanje s iskoristivosti p.p. od 36.31%

- Posmik:

$$\frac{h_w}{t_w} = \frac{h - 2 \cdot t_f}{t_w} = 22 \leq 72 \frac{\epsilon}{\eta} = 72 \frac{0.81}{1.20} = 48.60$$

Nije potrebna kontrola izbočavanja hrpta uslijed djelovanja posmika!

$$A_{v,z} = A - 2 \cdot b \cdot t_f + (t_w + 2 \cdot r) \cdot t_f = 4.78 \text{ (cm}^2) \geq \eta \cdot h_w \cdot t_w = 4.22 \text{ (cm}^2) \quad \text{Uvjet zadovoljen!}$$

$$V_{Rd}^z = V_{pl,Rd} = \frac{A_{v,z} \cdot f_y}{\sqrt{3} \cdot \gamma_{m0}} = \frac{4.78 \cdot 35.5}{1.7321} = 97.97 \text{ (kN)}$$

$$V_{Rd}^z = 97.97 \text{ (kN)} \geq V_{Ed} = 5.40 \text{ (kN)}$$

Profil zadovoljava na posmik s iskoristivosti p.p. od 5.51%

- Interakcija M-V-N:

$$N_{Ed} = 0 \text{ (kN)}$$

$$0.5 \cdot V_{z,Rd} = 48.96 \text{ (kN)} \geq V_{Ed} = 5.40 \text{ (kN)}$$

Nema redukcije  $M_{c,Rd}$  uslijed interakcije reznih sila!

### Otpornost elementa:

- Savijanje:

$$L_{CR} = 5.40 \text{ (m)} \approx 540 \text{ (cm)} \quad z_G = \frac{h}{2} = 2.7 \text{ (cm)}$$

$$k = 1.0 \quad C_1 = 1.67$$

$$k_w = 1.0 \quad C_2 = 0.78$$

$$M_{CR} = C_1 \cdot \frac{\pi^2 \cdot E \cdot I_z}{(k \cdot L_{CR})^2} \cdot \left[ \sqrt{\left(\frac{k}{k_w}\right)^2 \cdot \frac{I_w}{I_z} + \frac{(k \cdot L_{CR})^2 \cdot G \cdot I_T}{\pi^2 \cdot E \cdot I_z}} + (C_2 \cdot z_G)^2 - C_2 \cdot z_G \right] = 5.58 \text{ (kNm)}$$

$$\lambda_{LT} = \sqrt{\frac{W_{ELY} \cdot f_y}{M_{CR}}} = 1.58 \geq \lambda_{LT,0} = 0.4 \quad \text{Reduciramo } M_{c,Rd} \text{ zbog mogućnosti instabiliteta elementa.}$$

$$\text{Faktor imperfekcije: } \alpha_{LT} = 0.34 \quad \leftarrow \quad \text{Krivulja izvijanja : } b \begin{cases} \frac{h}{b} = 1.08 \leq 2 \\ \text{Vruće valjani I presjek} \end{cases}$$

$$\Phi_{LT} = 0.5 \cdot (1 + \alpha_{LT}(\lambda_{LT} - 0.2) + \lambda_{LT}^2) = 1.98$$

$$\chi_{LT} = \frac{1}{\Phi_{LT} + \sqrt{\Phi_{LT}^2 - \lambda_{LT}^2}} = 0.39$$

$$M_{B,Rd} = \chi_{LT} \cdot \frac{W_{pl,y} \cdot f_y}{\gamma_{m1}} = 0.39 \cdot \frac{39.4 \cdot 35.5}{1} = 5.50 \text{ (kNm)} \geq M_{Ed} = 5.08 \text{ (kNm)}$$

Profil IPE 100 zadovoljava otpornost elementa s iskoristivosti od 92.36%

### 5.2.6. Vertikale sprega

<b>PROFIL:</b>		<b>CFRHS 70x70x4.0</b>	$\epsilon = 0.81$		
<b>KVALITETA ČELIKA:</b>	S355	$f_y = 35.5 \text{ (kN/cm}^2\text{)}$	$f_u = 49.0 \text{ (kN/cm}^2\text{)}$		
<b>GEOMETRIJSKI PODATCI PROFILA:</b>					
b (cm)	7.0	t (cm)	0.4	b (cm)	4.0
h (cm)	7.0	A (cm <sup>2</sup> )	10.15	h (cm)	8.0
$W_{pl,Y} \text{ (cm}^3\text{)}$	24.76	$I_y \text{ (cm}^4\text{)}$	72.12	$W_{pl,Y} \text{ (cm}^3\text{)}$	20.91
$W_{pl,Z} \text{ (cm}^3\text{)}$	24.76	$I_z \text{ (cm}^4\text{)}$	72.12	$W_{pl,Z} \text{ (cm}^3\text{)}$	12.77
<b>MEHANIČKI PODATCI ČELIKA:</b>					
E (kN/cm <sup>2</sup> )	21000	G (kN/cm <sup>2</sup> )	8077	E (kN/cm <sup>2</sup> )	21000

#### Rezne sile uslijed kritične kombinacije:

$$M_{Ed} = 0 \text{ (kNm)}$$

$$V_{Ed} = 0 \text{ (kN)}$$

$$N_{Ed} = -328.72 \text{ (kN)}$$

#### Klasifikacija poprečnog presjeka:

- Hrbat:

$$\frac{d}{t} = \frac{h-3*t}{t} = 9.5$$

$$\text{Uvjet za klasu 1: } \frac{d}{t} \leq 33 \epsilon = 26.73$$

Hrbat je klase 1

Poprečni presjek je klase 1.

#### Otpornost poprečnog presjeka:

- Uzdužna tlačna sila

$$N_{c,Rd} = N_{pl,Rd} = \frac{A * f_y}{\gamma_{M,0}} = \frac{8.55 * 35.5}{1} = 303.53 \text{ (kN)} \geq N_{Ed} = 102.84 \text{ (kN)}$$

Profil zadovoljava na tlačnu silu s iskoristivosti p.p. od 33.88%

### Otpornost elementa:

- Tlačna sila:

$$L_i = 1.47 \text{ (m)} = 147 \text{ (cm)}$$

$$N_{CR} = \frac{\pi^2 * E * I_z}{L_i^2} = 206.68 \text{ (kN)}$$

Izvijanje oko osi: Y-Y ili Z-Z

Faktor imperfekcije:  $\alpha = 0.49$  ← Linija izvijanja: a ← Vruće dogotovljeni

$$\lambda_z = \sqrt{\frac{A * f_y}{N_{CR}}} = 1.21 \rightarrow \text{Očitano za liniju izvijanja a: } \chi_z = 0.43$$

$$N_{B,Rd} = \chi * \frac{A * f_y}{\gamma_{m1}} = 129.96 \text{ (kN)} \geq N_{Ed} = 102.84 \text{ (kN)}$$

Profil CFRHS 80/40/4 zadovoljava otpor. elementa s iskoristivosti od 79.13%

## **6. PRORAČUN SPOJEVA**

- 6.1. Proračun spoja temelj - stup
- 6.2. Proračun vlačnog nastavka rešetke
- 6.3. Proračun spoja stup - rešetka



**Project:**  
**Project no:**  
**Author:**

## Project data

Project name  
Project number  
Author  
Description  
Date 14/09/2022  
Design code EN

## Material

Steel S 355  
Concrete C25/30

Project:  
 Project no:  
 Author:

## Project item stup-temelj

### Design

Name: stup-temelj  
 Description:  
 Analysis: Stress, strain/ loads in equilibrium

### Members

#### Geometry

Name	Cross-section	$\beta$ - Direction [°]	$\gamma$ - Pitch [°]	$\alpha$ - Rotation [°]	Offset ex [mm]	Offset ey [mm]	Offset ez [mm]	Forces in
COL	2 - HEA280	0.0	-90.0	0.0	0	0	0	Node

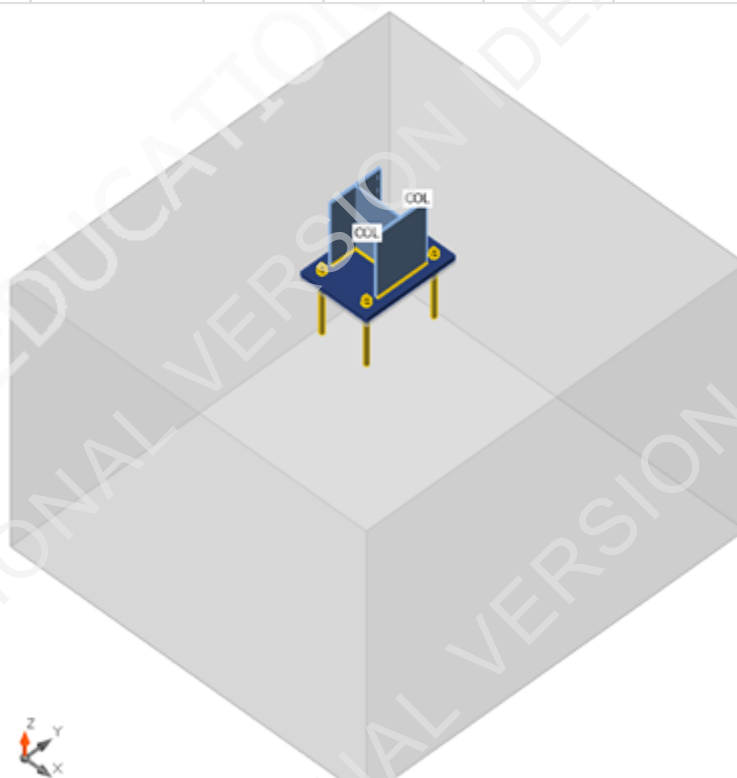

#### Cross-sections

Name	Material
2 - HEA280	S 355

#### Anchors

Name	Bolt assembly	Diameter [mm]	$f_u$ [MPa]	Gross area [mm <sup>2</sup> ]
M24 8.8	M24 8.8	24	800.0	452

Project:  
Project no:  
Author:

### Load effects (forces in equilibrium)

Name	Member	N [kN]	Vy [kN]	Vz [kN]	Mx [kNm]	My [kNm]	Mz [kNm]
LE1	COL	-118.3	0.0	14.1	0.0	68.4	0.0

### Foundation block

Item	Value	Unit
<b>CB 1</b>		
Dimensions	2130 x 2000	mm
Depth	1500	mm
Anchor	M24 8.8	
Anchoring length	300	mm
Shear force transfer	Anchors	
Mortar joint	20	mm

### Check

### Summary

Name	Value	Status
Analysis	100.0%	OK
Plates	0.0 < 5.0%	OK
Anchors	93.1 < 100%	OK
Welds	99.5 < 100%	OK
Concrete block	27.8 < 100%	OK
Buckling	Not calculated	

### Plates

Name	Thickness [mm]	Loads	$\sigma_{Ed}$ [MPa]	$\epsilon_{Pl}$ [%]	$\sigma_{c,Ed}$ [MPa]	Status
COL-bfl 1	13.0	LE1	177.2	0.0	0.0	OK
COL-tfl 1	13.0	LE1	174.2	0.0	0.0	OK
COL-w 1	8.0	LE1	98.7	0.0	0.0	OK
BP1	25.0	LE1	250.2	0.0	0.0	OK

### Design data

Material	$f_y$ [MPa]	$\epsilon_{lim}$ [%]
S 355	355.0	5.0

### Symbol explanation

$\epsilon_{Pl}$	Strain
$\sigma_{Ed}$	Eq. stress
$\sigma_{c,Ed}$	Contact stress
$f_y$	Yield strength
$\epsilon_{lim}$	Limit of plastic strain

Project:  
Project no:  
Author:

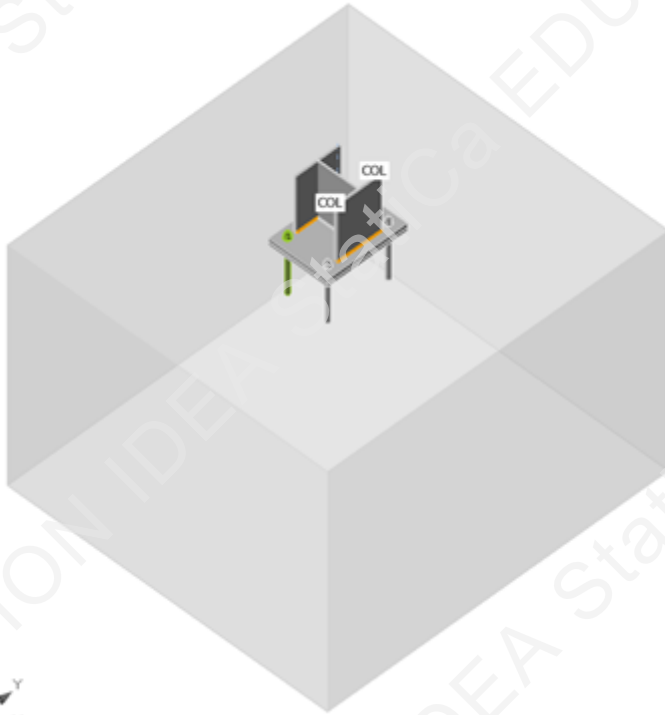

Overall check, LE1

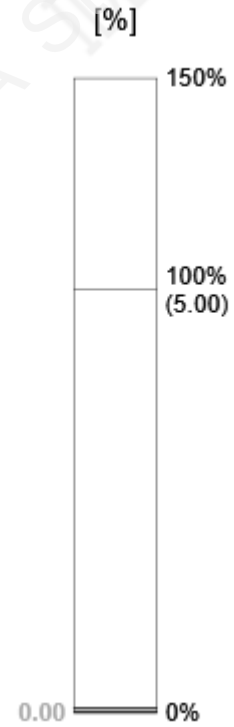
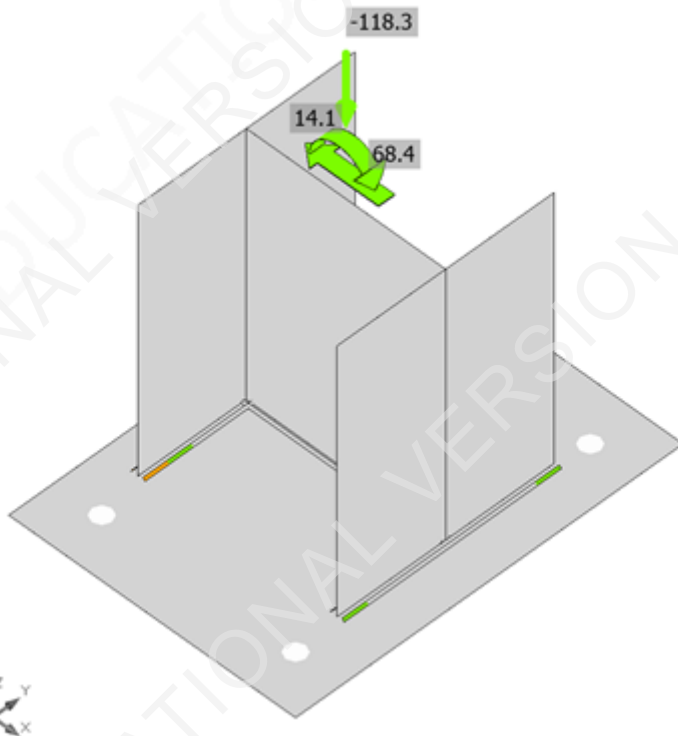

Strain check, LE1

Project:  
 Project no:  
 Author:

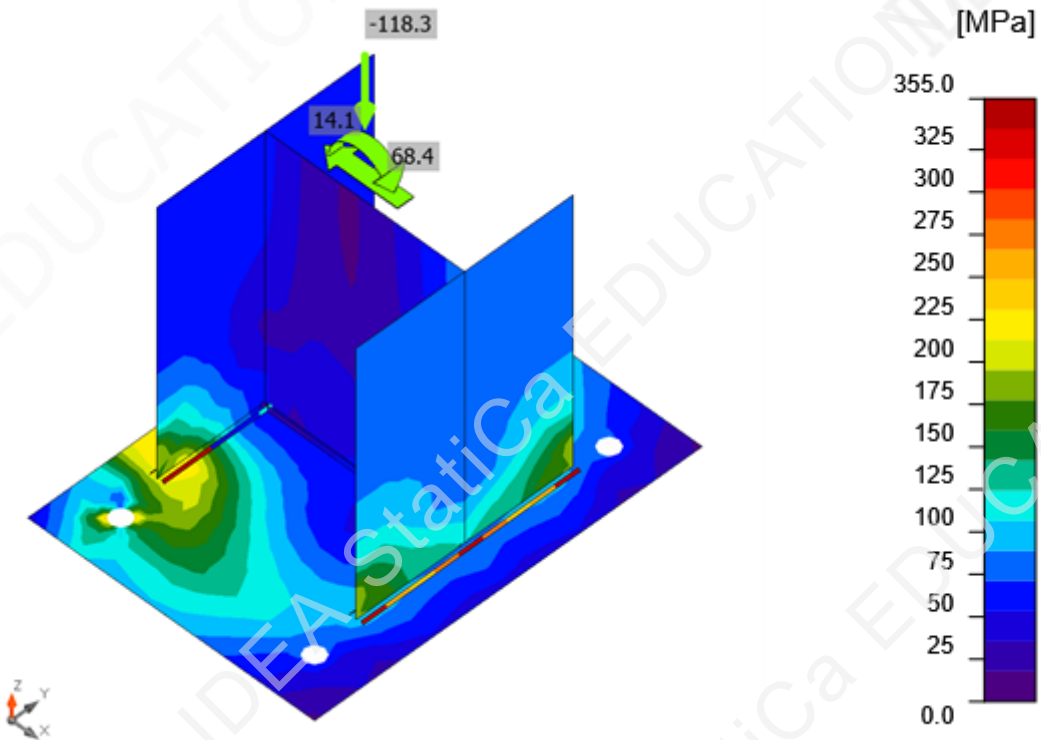

Equivalent stress, LE1

**Anchors**

Shape	Item	Loads	$N_{Ed}$ [kN]	$V_{Ed}$ [kN]	$N_{Rd,c}$ [kN]	$V_{Rd,s}$ [kN]	$V_{Rd,c}$ [kN]	$V_{Rd,cp}$ [kN]	$U_t$ [%]	$U_s$ [%]	$U_{ts}$ [%]	Status
	A1	LE1	108.1	4.0	232.4	10.5	169.4	484.4	93.1	38.6	92.2	OK
	A2	LE1	108.2	4.0	232.4	10.5	169.4	484.4	93.1	38.7	92.2	OK
	A3	LE1	0.0	3.5	-	32.3	-	484.4	0.0	10.8	1.2	OK
	A4	LE1	0.0	3.5	-	32.3	-	484.4	0.0	10.8	1.2	OK

**Design data**

Grade	$N_{Rd,s}$ [kN]
M24 8.8 - 1	160.0

Project:  
Project no:  
Author:

### Symbol explanation

$N_{Ed}$	Tension force
$V_{Ed}$	Resultant of bolt shear forces $V_y$ and $V_z$ in shear planes
$N_{Rd,c}$	Design resistance in case of concrete cone failure under tension load - EN1992-4 - Cl. 7.2.1.4
$V_{Rd,s}$	Design shear resistance in case of steel failure - EN1992-4 - Cl.7.2.2.3.2
$V_{Rd,c}$	Design resistance in case of concrete cone failure under shear load - EN1992-4 - Cl. 7.2.2.5
$V_{Rd,cp}$	Design resistance in case of concrete pryout failure - EN1992-4 - Cl. 7.2.2.4
$U_t$	Utilization in tension
$U_s$	Utilization in shear
$U_{ts}$	Utilization in tension and shear
$N_{Rd,s}$	Design tensile resistance of a fastener in case of steel failure - EN1992-4 - Cl. 7.2.1.3

### Welds

Item	Edge	Throat th. [mm]	Length [mm]	Loads	$\sigma_{w,Ed}$ [MPa]	$\epsilon_{pl}$ [%]	$\sigma_{\perp}$ [MPa]	$\tau_{\parallel}$ [MPa]	$\tau_{\perp}$ [MPa]	$U_t$ [%]	$U_{tc}$ [%]	Status
BP1	COL-bfl 1	▲ 4.0 ▼	280	LE1	376.6	0.0	-125.8	-121.6	-165.0	86.5	46.9	OK
		▲ 4.0 ▼	280	LE1	427.0	0.1	-193.2	143.3	166.8	98.0	70.4	OK
BP1	COL-tfl 1	▲ 4.0 ▼	280	LE1	433.2	3.7	196.2	114.1	191.6	99.5	58.0	OK
		▲ 4.0 ▼	280	LE1	433.0	3.5	189.5	-112.7	-194.5	99.4	52.4	OK
BP1	COL-w 1	▲ 4.0 ▼	257	LE1	75.9	0.0	37.6	5.5	37.7	17.4	11.5	OK
		▲ 4.0 ▼	257	LE1	75.5	0.0	37.5	-5.6	-37.4	17.3	11.5	OK

### Design data

	$\beta_w$ [-]	$\sigma_{w,Rd}$ [MPa]	$0.9 \sigma$ [MPa]
S 355	0.90	435.6	352.8

### Symbol explanation

▲	Fillet weld
$\epsilon_{pl}$	Strain
$\sigma_{w,Ed}$	Equivalent stress
$\sigma_{w,Rd}$	Equivalent stress resistance
$\sigma_{\perp}$	Perpendicular stress
$\tau_{\parallel}$	Shear stress parallel to weld axis
$\tau_{\perp}$	Shear stress perpendicular to weld axis
$0.9 \sigma$	Perpendicular stress resistance - $0.9 \cdot f_u / \gamma_{M2}$
$\beta_w$	Corelation factor EN 1993-1-8 tab. 4.1
$U_t$	Utilization
$U_{tc}$	Weld capacity utilization

### Concrete block

Item	Loads	$c$ [mm]	$A_{eff}$ [mm <sup>2</sup> ]	$\sigma$ [MPa]	$k_j$ [-]	$F_{jd}$ [MPa]	$U_t$ [%]	Status
CB 1	LE1	47	37487	9.3	3.00	33.5	27.8	OK

**Project:**  
**Project no:**  
**Author:**

### Symbol explanation

c	Bearing width
$A_{eff}$	Effective area
$\sigma$	Average stress in concrete
$k_j$	Concentration factor
$F_{jd}$	The ultimate bearing strength of the concrete block
$U_t$	Utilization

### Buckling

**Buckling analysis was not calculated.**

### Code settings

Item	Value	Unit	Reference
Y <sub>M0</sub>	1.00	-	EN 1993-1-1: 6.1
Y <sub>M1</sub>	1.00	-	EN 1993-1-1: 6.1
Y <sub>M2</sub>	1.25	-	EN 1993-1-1: 6.1
Y <sub>M3</sub>	1.25	-	EN 1993-1-8: 2.2
Y <sub>C</sub>	1.50	-	EN 1992-1-1: 2.4.2.4
Y <sub>Inst</sub>	1.20	-	EN 1992-4: Table 4.1
Joint coefficient $\beta_j$	0.67	-	EN 1993-1-8: 6.2.5
Effective area - influence of mesh size	0.10	-	
Friction coefficient - concrete	0.25	-	EN 1993-1-8
Friction coefficient in slip-resistance	0.30	-	EN 1993-1-8 tab 3.7
Limit plastic strain	0.05	-	EN 1993-1-5
Detailing	No		
Distance between bolts [d]	2.20	-	EN 1993-1-8: tab 3.3
Distance between bolts and edge [d]	1.20	-	EN 1993-1-8: tab 3.3
Concrete breakout resistance check	Both		EN 1992-4: 7.2.1.4 and 7.2.2.5
Use calculated $\alpha_b$ in bearing check.	Yes		EN 1993-1-8: tab 3.4
Cracked concrete	Yes		EN 1992-4
Local deformation check	No		CIDECT DG 1, 3 - 1.1
Local deformation limit	0.03	-	CIDECT DG 1, 3 - 1.1
Geometrical nonlinearity (GMNA)	Yes		Analysis with large deformations for hollow section joints
Braced system	No		EN 1993-1-8: 5.2.2.5

**Project:**  
**Project no:**  
**Author:**

## Project data

Project name  
Project number  
Author  
Description  
Date 14/09/2022  
Design code EN

## Material

Steel S 355



Project:  
 Project no:  
 Author:

## Project item CON1

### Design

Name CON1  
 Description  
 Analysis Stress, strain/ loads in equilibrium

### Members

#### Geometry

Name	Cross-section	$\beta$ - Direction [°]	$\gamma$ - Pitch [°]	$\alpha$ - Rotation [°]	Offset ex [mm]	Offset ey [mm]	Offset ez [mm]	Forces in
B1	3 - SHS100/100/5.0	0.0	0.0	0.0	0	0	0	Node
B2	3 - SHS100/100/5.0	180.0	0.0	0.0	0	0	0	Node

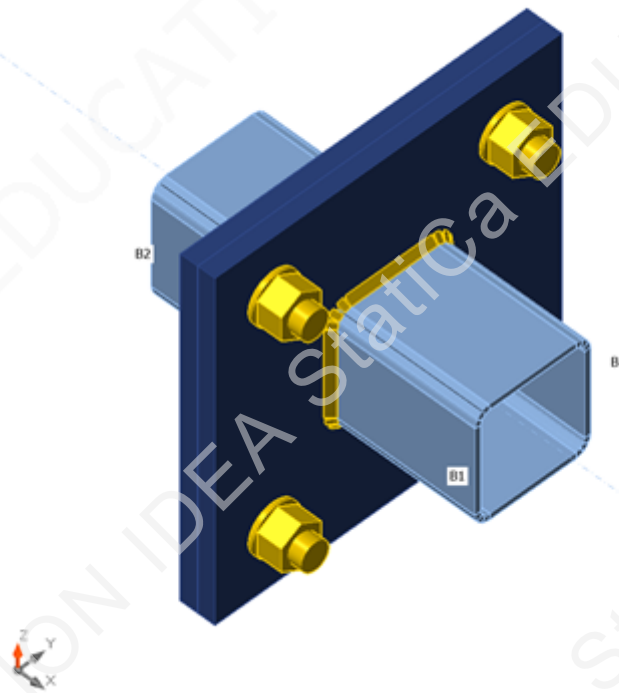

### Cross-sections

Name	Material
3 - SHS100/100/5.0	S 355

### Bolts

Name	Bolt assembly	Diameter [mm]	$f_u$ [MPa]	Gross area [mm <sup>2</sup> ]
M24 8.8	M24 8.8	24	800.0	452

Project:  
Project no:  
Author:

### Load effects (forces in equilibrium)

Name	Member	N [kN]	Vy [kN]	Vz [kN]	Mx [kNm]	My [kNm]	Mz [kNm]
LE1	B1	268.9	0.0	0.0	0.0	0.0	0.0
	B2	0.0	0.0	0.0	0.0	0.0	0.0

### Check

#### Summary

Name	Value	Status
Analysis	100.0%	OK
Plates	0.3 < 5.0%	OK
Bolts	80.7 < 100%	OK
Welds	99.1 < 100%	OK
Buckling	Not calculated	
GMNA	Calculated	

#### Plates

Name	Thickness [mm]	Loads	$\sigma_{Ed}$ [MPa]	$\epsilon_{pl}$ [%]	$\sigma_{c,Ed}$ [MPa]	Status
B1	5.0	LE1	354.0	0.1	0.0	OK
B2	5.0	LE1	354.0	0.1	0.0	OK
PP1a	15.0	LE1	355.6	0.3	105.2	OK
PP1b	15.0	LE1	355.6	0.3	105.2	OK

#### Design data

Material	$f_y$ [MPa]	$\epsilon_{lim}$ [%]
S 355	355.0	5.0

#### Symbol explanation

$\epsilon_{pl}$	Strain
$\sigma_{Ed}$	Eq. stress
$\sigma_{c,Ed}$	Contact stress
$f_y$	Yield strength
$\epsilon_{lim}$	Limit of plastic strain

Project:  
Project no:  
Author:

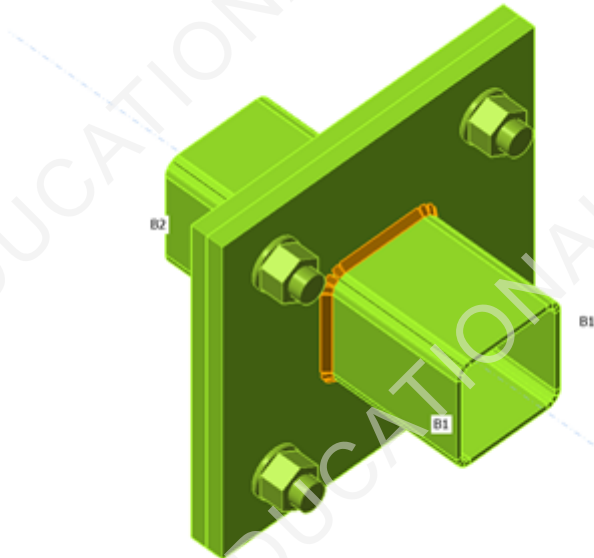

Overall check, LE1

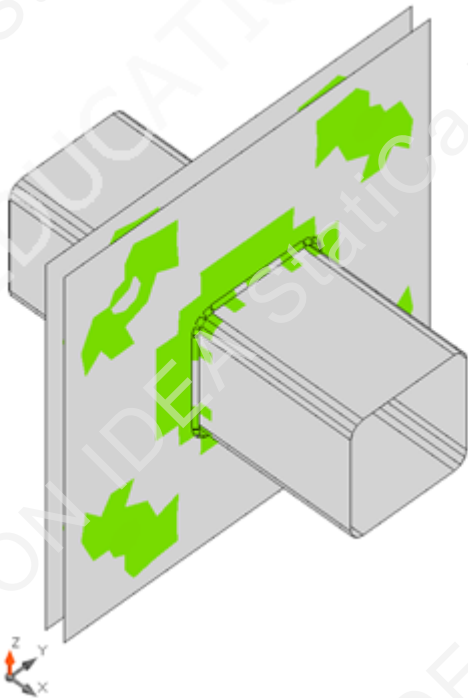

Strain check, LE1

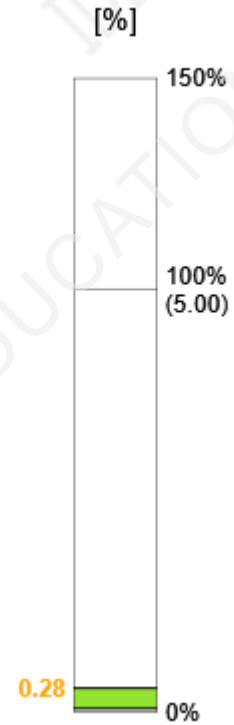

Project:  
Project no:  
Author:

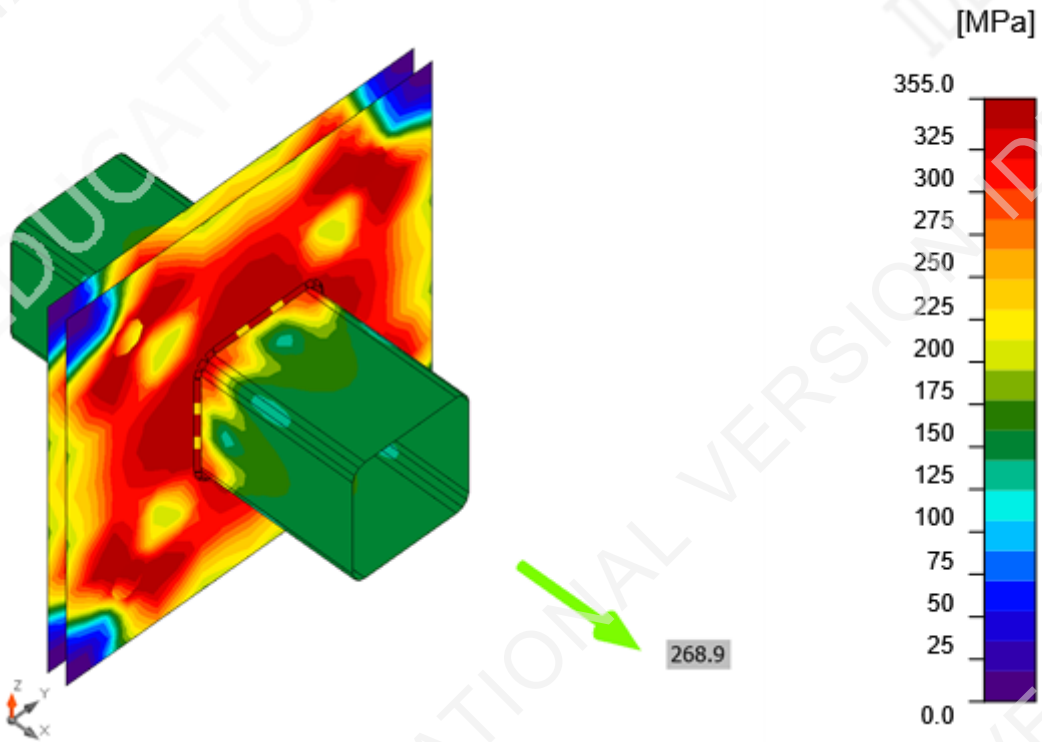

Equivalent stress, LE1

**Bolts**

	Name	Loads	$F_{t,Ed}$ [kN]	V [kN]	$U_{t_t}$ [%]	$F_{b,Rd}$ [kN]	$U_{t_s}$ [%]	$U_{t_{ts}}$ [%]	Status
	B1	LE1	164.1	0.0	80.7	231.8	0.0	57.6	OK
	B2	LE1	164.1	0.0	80.7	233.3	0.0	57.6	OK
	B3	LE1	164.1	0.0	80.7	231.7	0.0	57.6	OK
	B4	LE1	164.1	0.0	80.7	233.5	0.0	57.6	OK

**Design data**

Name	$F_{t,Rd}$ [kN]	$B_{p,Rd}$ [kN]	$F_{v,Rd}$ [kN]
M24 8.8 - 1	203.3	421.1	135.6

**Symbol explanation**

- $F_{t,Rd}$  Bolt tension resistance EN 1993-1-8 tab. 3.4
- $F_{t,Ed}$  Tension force
- $B_{p,Rd}$  Punching shear resistance
- V Resultant of bolt shear forces  $V_y$  and  $V_z$  in shear planes
- $F_{v,Rd}$  Bolt shear resistance EN\_1993-1-8 table 3.4
- $F_{b,Rd}$  Plate bearing resistance EN 1993-1-8 tab. 3.4
- $U_{t_t}$  Utilization in tension
- $U_{t_s}$  Utilization in shear

Project:  
Project no:  
Author:

## Welds

Item	Edge	Throat th. [mm]	Length [mm]	Loads	$\sigma_{w,Ed}$ [MPa]	$\epsilon_{pl}$ [%]	$\sigma_{\perp}$ [MPa]	$\tau_{\parallel}$ [MPa]	$\tau_{\perp}$ [MPa]	Ut [%]	Ut <sub>c</sub> [%]	Status
PP1a	B2	▲ 4.0	362	LE1	431.5	2.7	317.8	-98.4	-136.8	99.1	88.9	OK
PP1b	B1	▲ 4.0	362	LE1	431.5	2.7	317.7	98.3	-136.9	99.1	88.9	OK

## Design data

	$\beta_w$ [-]	$\sigma_{w,Rd}$ [MPa]	0.9 $\sigma$ [MPa]
S 355	0.90	435.6	352.8

## Symbol explanation

▲	Fillet weld
$\epsilon_{pl}$	Strain
$\sigma_{w,Ed}$	Equivalent stress
$\sigma_{w,Rd}$	Equivalent stress resistance
$\sigma_{\perp}$	Perpendicular stress
$\tau_{\parallel}$	Shear stress parallel to weld axis
$\tau_{\perp}$	Shear stress perpendicular to weld axis
0.9 $\sigma$	Perpendicular stress resistance - 0.9*fu/γM2
$\beta_w$	Corelation factor EN 1993-1-8 tab. 4.1
Ut	Utilization
Ut <sub>c</sub>	Weld capacity utilization

## Buckling

Buckling analysis was not calculated.

Project:  
Project no:  
Author:

## Code settings

Item	Value	Unit	Reference
Y <sub>M0</sub>	1.00	-	EN 1993-1-1: 6.1
Y <sub>M1</sub>	1.00	-	EN 1993-1-1: 6.1
Y <sub>M2</sub>	1.25	-	EN 1993-1-1: 6.1
Y <sub>M3</sub>	1.25	-	EN 1993-1-8: 2.2
Y <sub>C</sub>	1.50	-	EN 1992-1-1: 2.4.2.4
Y <sub>Inst</sub>	1.20	-	EN 1992-4: Table 4.1
Joint coefficient β <sub>j</sub>	0.67	-	EN 1993-1-8: 6.2.5
Effective area - influence of mesh size	0.10	-	
Friction coefficient - concrete	0.25	-	EN 1993-1-8
Friction coefficient in slip-resistance	0.30	-	EN 1993-1-8 tab 3.7
Limit plastic strain	0.05	-	EN 1993-1-5
Detailing	No		
Distance between bolts [d]	2.20	-	EN 1993-1-8: tab 3.3
Distance between bolts and edge [d]	1.20	-	EN 1993-1-8: tab 3.3
Concrete breakout resistance check	Both		EN 1992-4: 7.2.1.4 and 7.2.2.5
Use calculated a <sub>b</sub> in bearing check.	Yes		EN 1993-1-8: tab 3.4
Cracked concrete	Yes		EN 1992-4
Local deformation check	No		CIDECT DG 1, 3 - 1.1
Local deformation limit	0.03	-	CIDECT DG 1, 3 - 1.1
Geometrical nonlinearity (GMNA)	Yes		Analysis with large deformations for hollow section joints
Braced system	No		EN 1993-1-8: 5.2.2.5

**Project:** Spoj stup-greda  
**Project no:**  
**Author:** Ivan Delaš

## Project data

Project name Spoj stup-greda  
Project number  
Author Ivan Delaš  
Description  
Date 14/09/2022  
Design code EN

## Material

Steel S 275, S 355

Project: Spoj stup-greda  
 Project no:  
 Author: Ivan Delaš

## Project item CON1

### Design

Name: CON1  
 Description:  
 Analysis: Stress, strain/ loads in equilibrium

### Members

#### Geometry

Name	Cross-section	$\beta$ - Direction [°]	$\gamma$ - Pitch [°]	$\alpha$ - Rotation [°]	Offset ex [mm]	Offset ey [mm]	Offset ez [mm]	Forces in
Stup	1 - HEA280	0.0	90.0	0.0	0	0	0	Node
Donji pojas	3 - SHS100/100/5.0	0.0	0.0	0.0	0	0	100	Node
Vertikala	4 - MQ140/140/7.1	0.0	-90.0	0.0	-420	0	0	Node

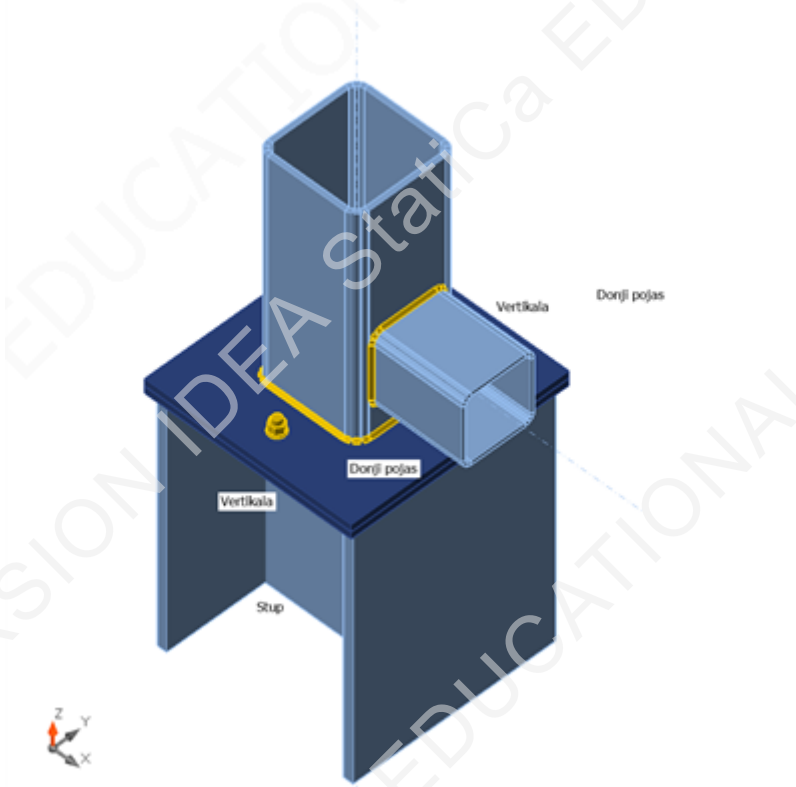

#### Cross-sections

Name	Material
1 - HEA280	S 355
3 - SHS100/100/5.0	S 355
4 - MQ140/140/7.1	S 355



Project: Spoj stup-greda

Project no:

Author: Ivan Delaš

## Bolts

Name	Bolt assembly	Diameter [mm]	$f_u$ [MPa]	Gross area [mm <sup>2</sup> ]
M12 8.8	M12 8.8	12	800.0	113

## Load effects (forces in equilibrium)

Name	Member	N [kN]	Vy [kN]	Vz [kN]	Mx [kNm]	My [kNm]	Mz [kNm]
LE1	Stup	0.0	0.0	0.0	0.0	0.0	0.0
	Donji pojas	-6.7	0.0	0.0	0.0	0.0	0.0
	Vertikala	-129.8	0.0	0.0	0.0	0.0	0.0
LE2	Stup	0.0	0.0	0.0	0.0	0.0	0.0
	Donji pojas	6.4	0.0	0.0	0.0	0.0	0.0
	Vertikala	6.1	0.0	0.0	0.0	0.0	0.0

## Check

### Summary

Name	Value	Status
Analysis	100.0%	OK
Plates	0.0 < 5.0%	OK
Bolts	20.2 < 100%	OK
Welds	98.1 < 100%	OK
Buckling	Not calculated	

## Plates

Name	Thickness [mm]	Loads	$\sigma_{Ed}$ [MPa]	$\epsilon_{pl}$ [%]	$\sigma_{c,Ed}$ [MPa]	Status
Stup-bfl 1	13.0	LE1	18.5	0.0	0.0	OK
Stup-tfl 1	13.0	LE1	13.5	0.0	0.0	OK
Stup-w 1	8.0	LE1	85.3	0.0	0.0	OK
Donji pojas	5.0	LE1	49.5	0.0	0.0	OK
Vertikala	7.1	LE1	114.6	0.0	0.0	OK
PP1a	10.0	LE2	109.9	0.0	9.2	OK
PP1b	10.0	LE2	87.9	0.0	9.2	OK

## Design data

Material	$f_y$ [MPa]	$\epsilon_{lim}$ [%]
S 355	355.0	5.0

Project: Spoj stup-greda

Project no:

Author: Ivan Delaš

### Symbol explanation

$\epsilon_{Pl}$	Strain
$\sigma_{Ed}$	Eq. stress
$\sigma_{c,Ed}$	Contact stress
$f_y$	Yield strength
$\epsilon_{lim}$	Limit of plastic strain

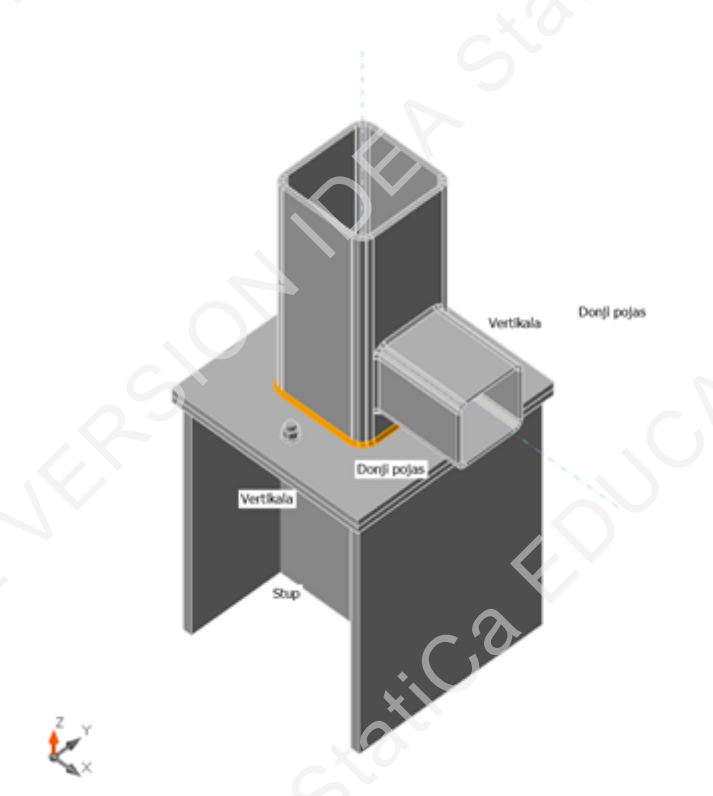

Overall check, LE1

Project: Spoj stup-greda  
Project no:  
Author: Ivan Delaš

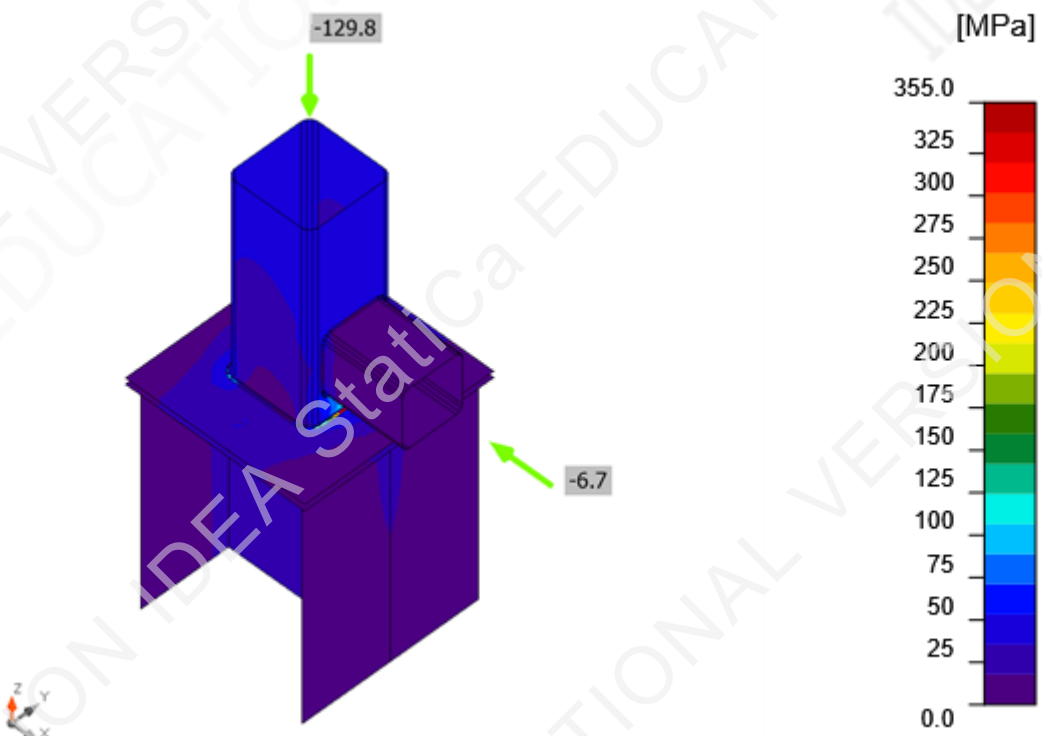
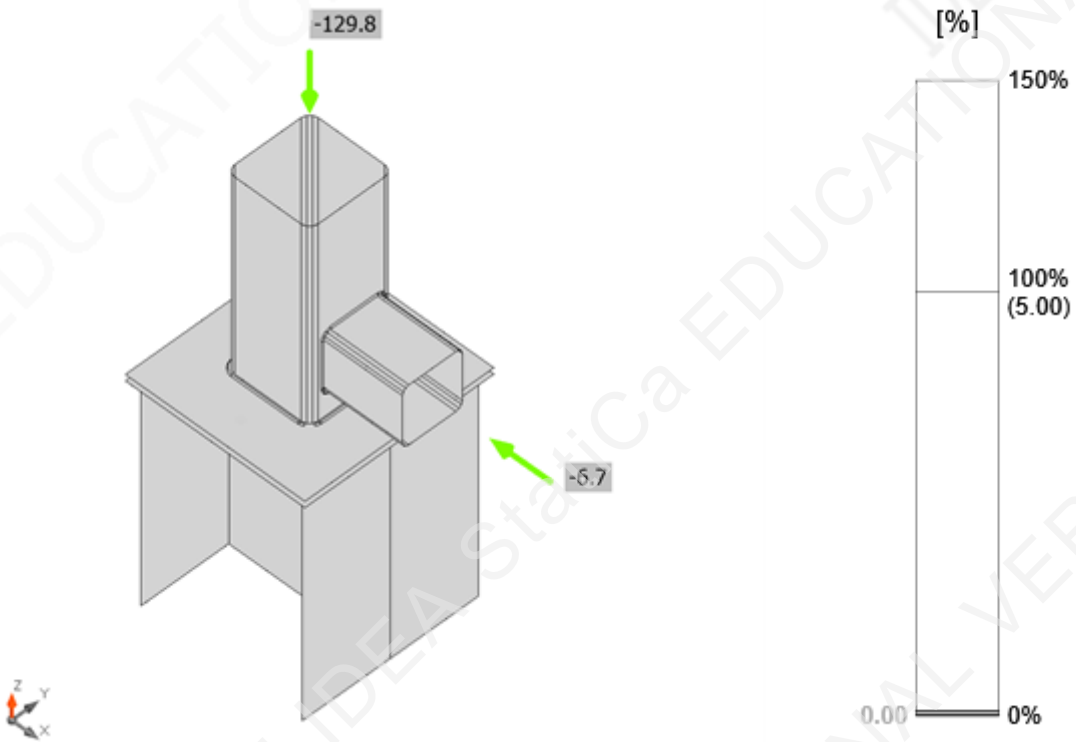

Project: Spoj stup-greda  
 Project no:  
 Author: Ivan Delaš

## Bolts

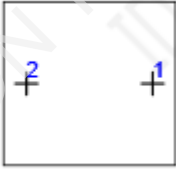
	Name	Loads	$F_{t,Ed}$ [kN]	V [kN]	$U_t$ [%]	$F_{b,Rd}$ [kN]	$U_s$ [%]	$U_{ts}$ [%]	Status
	B1	LE2	7.0	3.2	14.4	117.6	9.9	20.2	OK
	B2	LE2	7.0	3.2	14.4	117.6	9.9	20.2	OK

## Design data

Name	$F_{t,Rd}$ [kN]	$B_{p,Rd}$ [kN]	$F_{v,Rd}$ [kN]
M12 8.8 - 1	48.6	140.5	32.4

## Symbol explanation

$F_{t,Rd}$	Bolt tension resistance EN 1993-1-8 tab. 3.4
$F_{t,Ed}$	Tension force
$B_{p,Rd}$	Punching shear resistance
V	Resultant of bolt shear forces $V_y$ and $V_z$ in shear planes
$F_{v,Rd}$	Bolt shear resistance EN_1993-1-8 table 3.4
$F_{b,Rd}$	Plate bearing resistance EN 1993-1-8 tab. 3.4
$U_t$	Utilization in tension
$U_s$	Utilization in shear

## Welds

Item	Edge	Throat th. [mm]	Length [mm]	Loads	$\sigma_{w,Ed}$ [MPa]	$\epsilon_{pl}$ [%]	$\sigma_{\perp}$ [MPa]	$\tau_{\parallel}$ [MPa]	$\tau_{\perp}$ [MPa]	$U_t$ [%]	$U_c$ [%]	Status
PP1b	Vertikala	▲ 3.0	508	LE1	427.1	0.1	-211.4	1.8	214.2	98.1	33.0	OK
Vertikala-w 1	Donji pojas	▲ 3.0	362	LE1	69.1	0.0	-29.9	-36.0	1.2	15.9	6.4	OK
PP1a	Stup-bfl 1	▲ 3.0	280	LE1	56.6	0.0	-12.1	0.0	31.9	13.0	5.1	OK
PP1a	Stup-tfl 1	▲ 3.0	280	LE1	43.0	0.0	-9.7	0.0	-24.2	9.9	4.2	OK
PP1a	Stup-w 1	▲ 3.0	257	LE1	427.2	0.2	-213.4	7.1	213.5	98.1	55.5	OK

## Design data

	$\beta_w$ [-]	$\sigma_{w,Rd}$ [MPa]	$0.9 \sigma$ [MPa]
S 355	0.90	435.6	352.8

Project: Spoj stup-greda  
 Project no:  
 Author: Ivan Delaš

### Symbol explanation

▲	Fillet weld
$\epsilon_{PI}$	Strain
$\sigma_{w,Ed}$	Equivalent stress
$\sigma_{w,Rd}$	Equivalent stress resistance
$\sigma_{\perp}$	Perpendicular stress
$\tau_{\parallel}$	Shear stress parallel to weld axis
$\tau_{\perp}$	Shear stress perpendicular to weld axis
$0.9 \sigma$	Perpendicular stress resistance - $0.9 \cdot f_u / \gamma_{M2}$
$\beta_w$	Correlation factor EN 1993-1-8 tab. 4.1
Ut	Utilization
Utc	Weld capacity utilization

### Buckling

Buckling analysis was not calculated.

### Code settings

Item	Value	Unit	Reference
Y <sub>M0</sub>	1.00	-	EN 1993-1-1: 6.1
Y <sub>M1</sub>	1.00	-	EN 1993-1-1: 6.1
Y <sub>M2</sub>	1.25	-	EN 1993-1-1: 6.1
Y <sub>M3</sub>	1.25	-	EN 1993-1-8: 2.2
Y <sub>C</sub>	1.50	-	EN 1992-1-1: 2.4.2.4
Y <sub>Inst</sub>	1.20	-	EN 1992-4: Table 4.1
Joint coefficient $\beta_j$	0.67	-	EN 1993-1-8: 6.2.5
Effective area - influence of mesh size	0.10	-	
Friction coefficient - concrete	0.25	-	EN 1993-1-8
Friction coefficient in slip-resistance	0.30	-	EN 1993-1-8 tab 3.7
Limit plastic strain	0.05	-	EN 1993-1-5
Detailing	No		
Distance between bolts [d]	2.20	-	EN 1993-1-8: tab 3.3
Distance between bolts and edge [d]	1.20	-	EN 1993-1-8: tab 3.3
Concrete breakout resistance check	Both		EN 1992-4: 7.2.1.4 and 7.2.2.5
Use calculated $a_b$ in bearing check.	Yes		EN 1993-1-8: tab 3.4
Cracked concrete	Yes		EN 1992-4
Local deformation check	No		CIDECT DG 1, 3 - 1.1
Local deformation limit	0.03	-	CIDECT DG 1, 3 - 1.1
Geometrical nonlinearity (GMNA)	Yes		Analysis with large deformations for hollow section joints
Braced system	No		EN 1993-1-8: 5.2.2.5

## 7. PRORAČUN TEMELJA

Odabrane dimenzije temelja:

$$L = 2\text{ m} = 200\text{ cm}$$

$$B = 2\text{ m} = 200\text{ cm}$$

$$H = 1.5\text{ m} = 150\text{ cm}$$

Materijal:

- Temeljno tlo:  $\sigma_{\text{tem,lim}} = 300 \text{ kN/m}^2$

- Beton C 25/30:  $f_{\text{ck}} = 2.5 \text{ kN/cm}^2$

- Čelik B500B:  $f_{\text{yk}} = 5.0 \text{ kN/cm}^2$

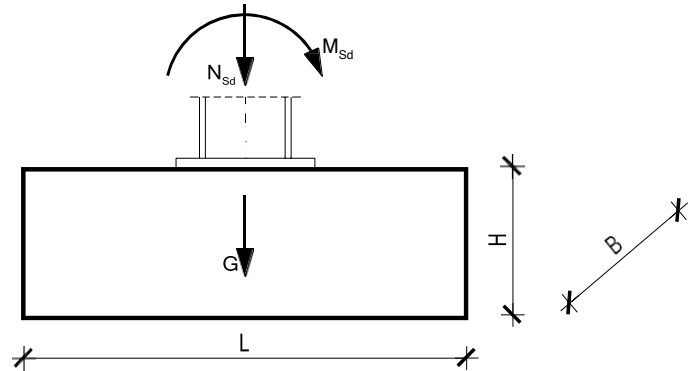

REZNE SILE:

$$M_{Ed} = 68.44 \text{ (kNm)}$$

$$V_{Ed} = 14.06 \text{ (kN)}$$

$$N_{Ed} = -118.31 \text{ (kN)}$$

Površina temeljne stope:  $A = L * B = 2 * 2 = 4 \text{ m}^2$

Težina temeljne stope:  $G = L * B * H * \gamma = 2 * 2 * 1.5 * 25 = 150 \text{ kN}$

Moment otpora temeljne stope:

$$W = \frac{B * L^2}{6} = \frac{2 * 2^2}{6} = 1.3333 \text{ m}^3$$

Naprezanje u tlu ispod temeljne stope na dubini temeljenja:

$$\sigma_{1,2} = \frac{N_{Ed} + G}{A} \pm \frac{M_{Ed}}{W} = \frac{118.31 + 150}{4} \pm \frac{68.44}{1.3333} \rightarrow \sigma_1 = 118.41 \text{ kN/m}^2 ; \sigma_2 = 15.75 \text{ kN/m}^2$$

$$e = \frac{M_{Ed}}{N_{Ed} + G} = \frac{68.44}{118.31 + 150} = 0.26$$

$$\frac{L}{2} = e + \frac{L'}{3} \rightarrow L' = 3 * \left( \frac{L}{2} - e \right) = 3 * \left( \frac{2}{2} - 0.26 \right) = 2.22 \text{ m}$$

$$\sigma_{\text{ekv}} = \frac{2 * (N_{Ed} + G)}{L' * B} = \frac{2 * (118.31 + 150)}{2.22 * 2} = 120.86 \text{ kN/m}^2 < \sigma_{\text{dop}} = 300 \text{ kN/m}^2$$

## Proračun armature temelja:

$$L_1 = \frac{L - h_{stup}}{2} = \frac{2 - 0.27}{2} = 0.87 \text{ m}$$

$$\frac{\sigma_{ekv}}{L' - L_1} = \frac{\sigma_{ekv}}{L'} \rightarrow \sigma_{1-1} = \frac{L' - L_1}{L'} * \sigma_{ekv} = \frac{2.22 - 0.87}{2.22} * 120.86 = 73.50 \text{ kN/m}^2$$

$$M_{Ed}^{1-1} = \gamma * \left( \sigma_{1-1} * \frac{L_1^2}{2} * B + \frac{\sigma_{ekv} - \sigma_{1-1}}{2} * L_1 * B * \frac{2}{3} * L_1 \right)$$

$$M_{Ed}^{1-1} = 1.4 * \left( 73.50 * \frac{0.87^2}{2} * 2 + \frac{120.86 - 73.50}{2} * 0.87 * 2 * \frac{2}{3} * 0.87 \right) = 111.34 \text{ kNm}$$

Krak unutarnjih sila:

$$z \approx 0.8 * H = 0.8 * 1.5 = 1.2$$

Potrebna površina armature:

$$A_{S1} = \frac{M_{Ed}^{1-1}}{z * \frac{f_{yk}}{\gamma_s}} = \frac{111.34}{1.2 * \frac{50}{1.15}} = 2.13 \text{ cm}^2 < A_{S1,min} = \frac{0.1}{100} * B * H = 30 \text{ cm}^2$$

Odabrana je minimalna armatura.

Odabrano:

Glavna armatura → Ø12/15

Razdjelna armatura → Ø8/25

## **8. NACRTI**

8.1. GENERALNI PLAN POZICIJA

8.2. PRESJEK KROZ GLAVNI OKVIR

8.3. RADIONIČKI NACRT GLAVNOG NOSAČA

8.4. RADIONIČKI NACRT SEKUNDARNE KONSTRUKCIJE

8.5. DETALJI SPOJEVA



TLOCRTNI POGLED

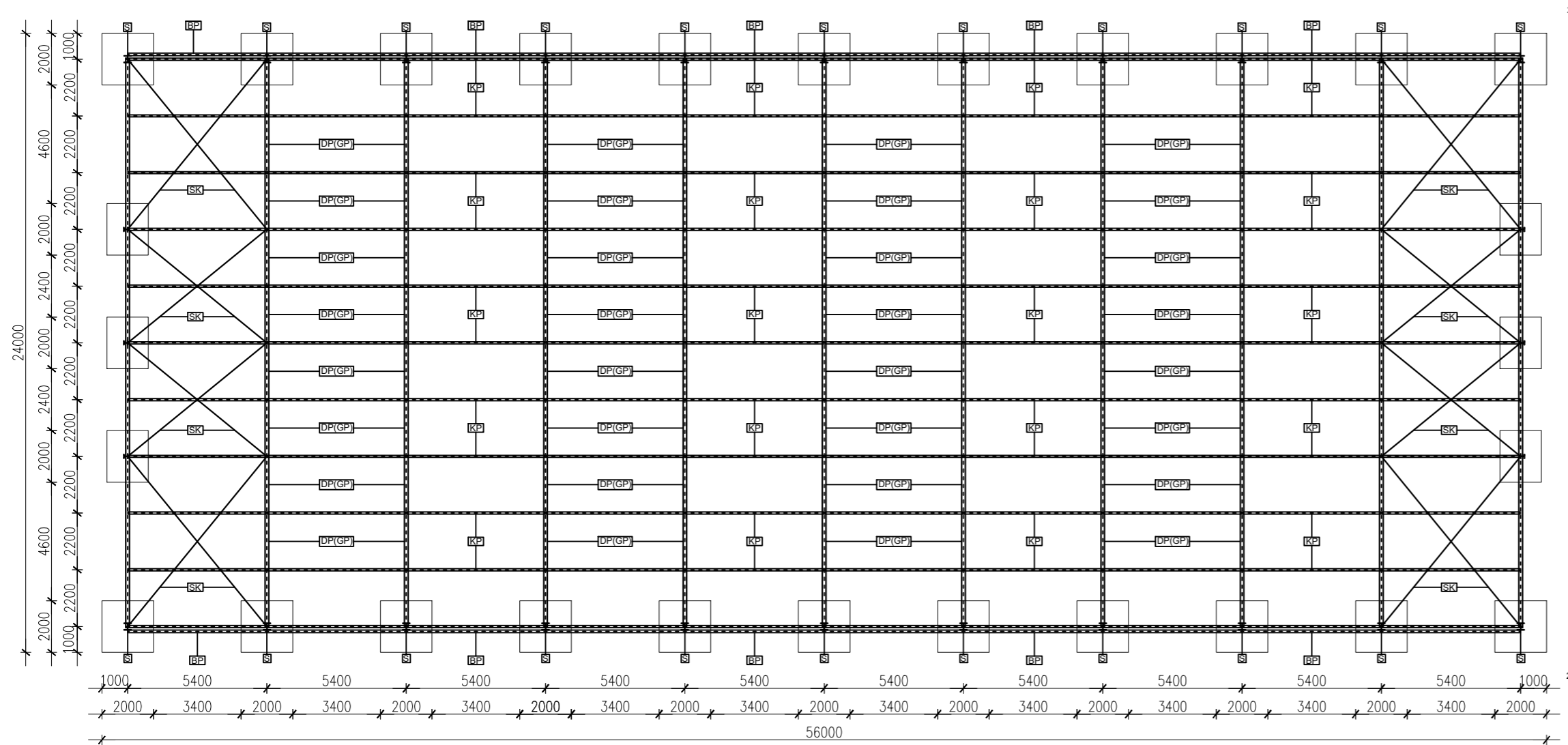

BOČNI POGLED

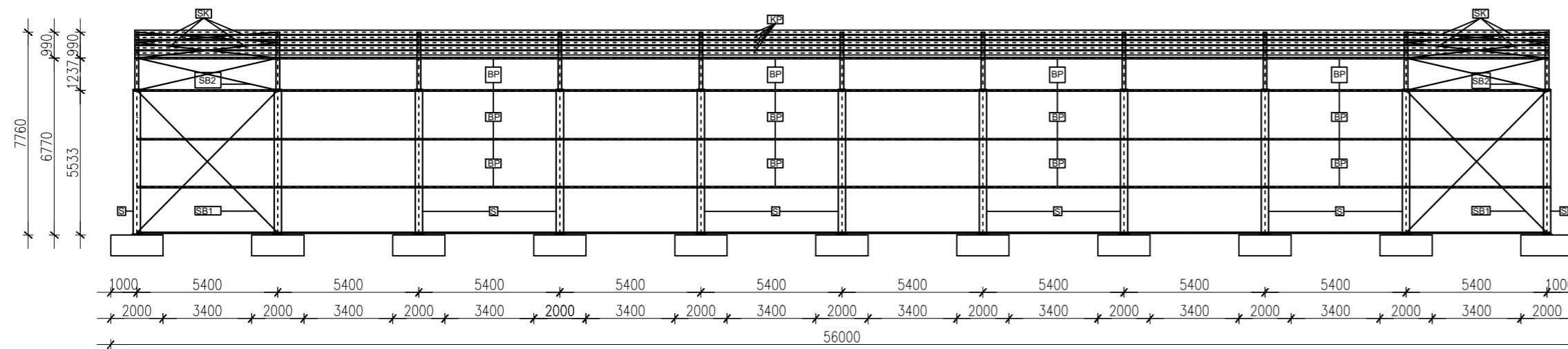

POPREČNI POGLED 2-2

GENERALNI PLAN POZICIJA  
M 1:200

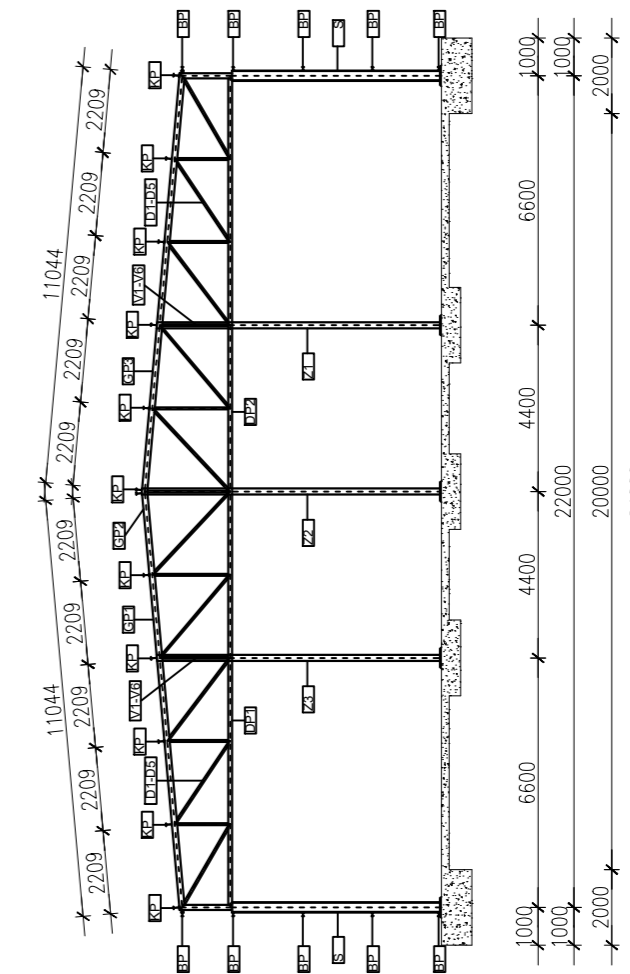

PRIKAZ I OPIS POZICIJA		
POZICIJA	PROFIL	NAZIV
STUP (S)	HEA280	Stup glavne konstrukcije
DONJI POJAS (DP)	CFRHS 100/100/5	Donji pojas krovne rešetke
GORNJI POJAS (GP)	CFRHS 140/140/7.1	Gornji pojas krovne rešetke
UNUTARNJE VERT. (V)	CFRHS 80/40/4.0	Unutarnje vertikalne ispunne krovne rešetke
VANJSKE VERT. (V1)	CFRHS 140/140/7.1	Vanjske vertikalne ispunne krovne rešetke
DIJAGONALE (K)	CFRHS 80/40/4.0	Dijagonalne ispunne krovne rešetke
KROVNA PODR. (KP)	IPE 160	Sekundarna krovna konstrukcija
BOČNA PODR. (BP)	IPE 100	Sekundarna bočna konstrukcija
KROVNI SPREG (SK)	RD 14	Krovna dijagonala vjetrovnog sprega
BOČNI SPREG (SB)	RD 14	Bočna dijagonala vjetrovnog sprega
ZABAT (Z)	HEA160A	Sekundarna konstrukcija na zabatu hale
VERTIK. SPREGA (VS)	CFRHS 70/70/4.0	Sekundarna krovna i bočna konstrukcija

Svi elementi su klase čelika S355

<p>Sveučilište u Zagrebu Fakultet arhitekture i geodetske 21000 SPLIT, MATIĆE HRVATSKÉ 15</p>	ZAVRŠNI RAD	
	ZADATAK: Projektiranje i dimenzioniranje hale	
	SADRŽAJ: Generalni plan pozicija	
	MJERILO: M 1:200	
STUDENT: Ivan Delaš	DATUM: 22.09.2022.	BROJ PRILOGA: 1

# PRESJEK KROZ GLAVNI OKVIR M 1:50

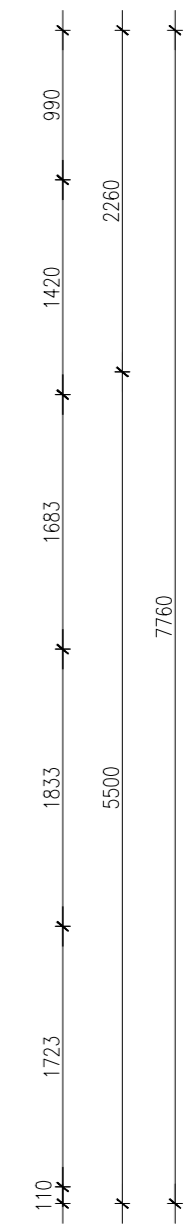
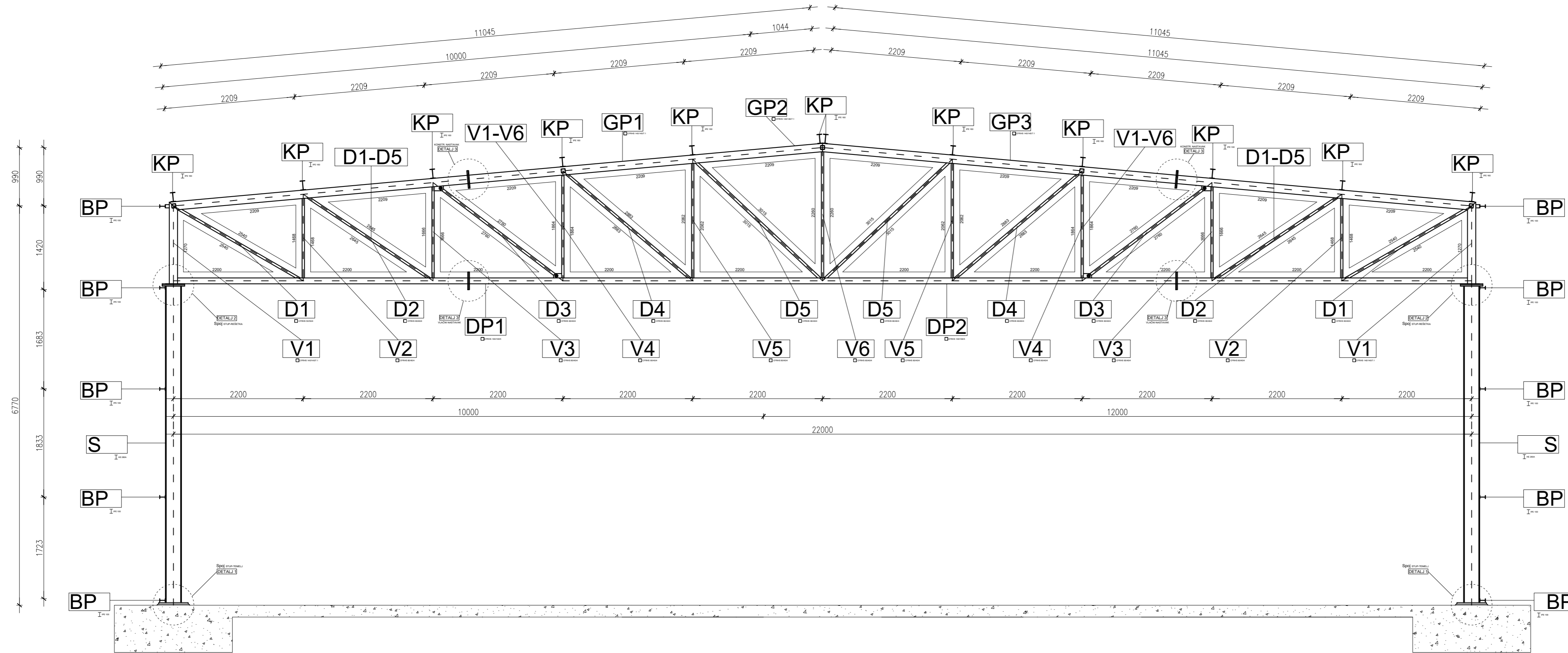

Svi elementi su klase čelika S355

 <p style="font-size: 8px;">Sveučilište u Splitu Fakultet Građevinarstva, Arhitekture i Geodezije 21000 SPLIT, MATICE HRVATSKE 15</p>	<b>ZAVRŠNI RAD</b>	
	ZADATAK: Projektiranje i dimenzioniranje hale	
SADRŽAJ: Presjek kroz glavni okvir		
STUDENT:  Ivan Delaš	MJERILO: M 1:50	
	DATUM: 22.09.2022.	BROJ PRILOGA: 2

# RADIONIČKI NACRT REŠETKE I STUPA M 1:25

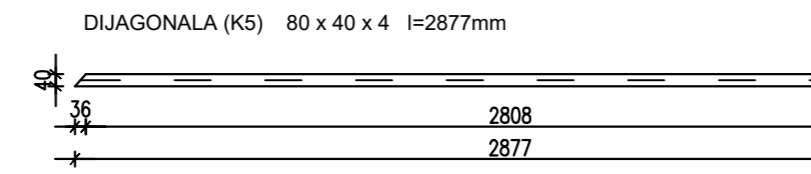
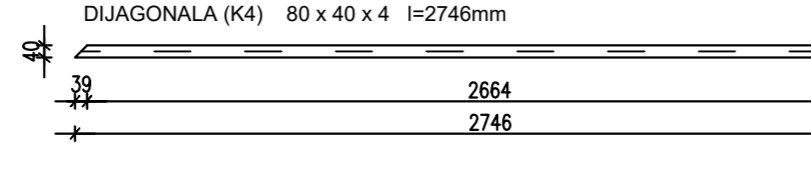
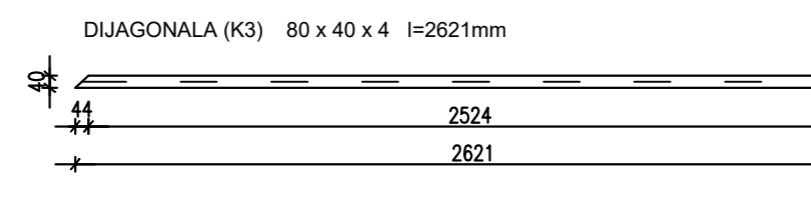
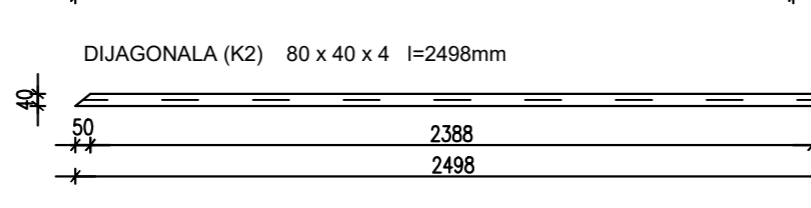
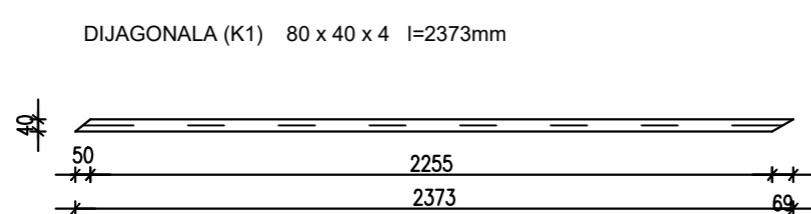
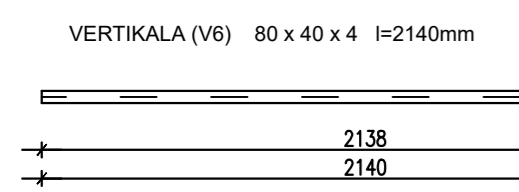
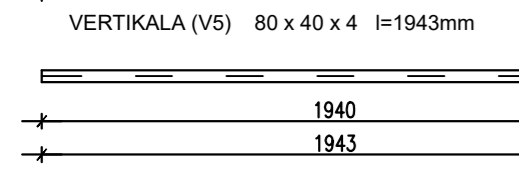
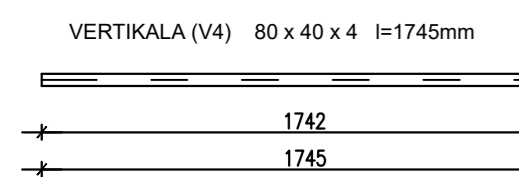
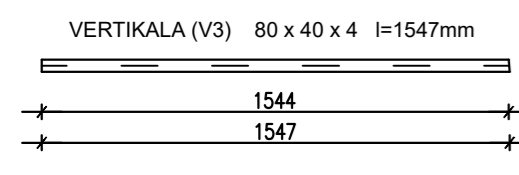
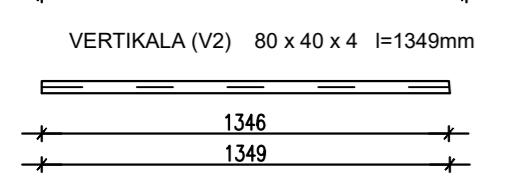
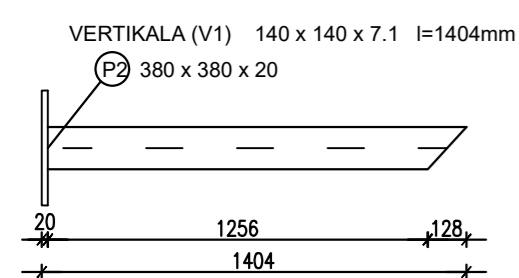
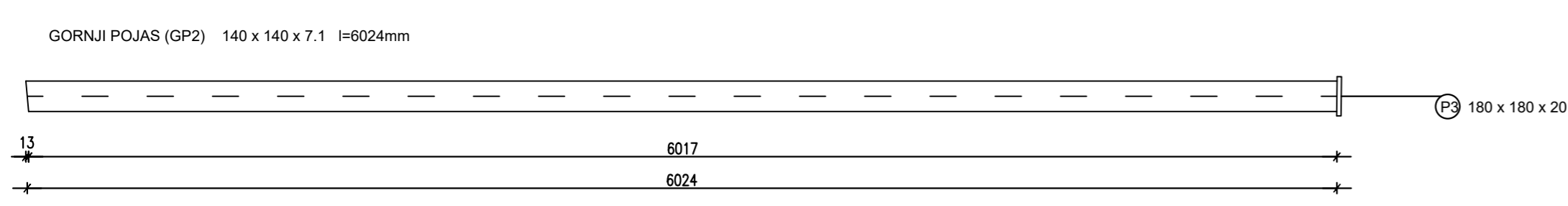
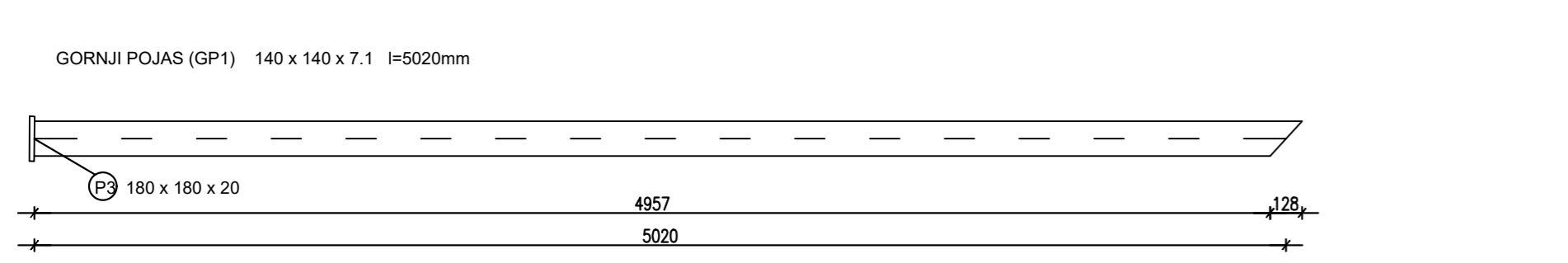
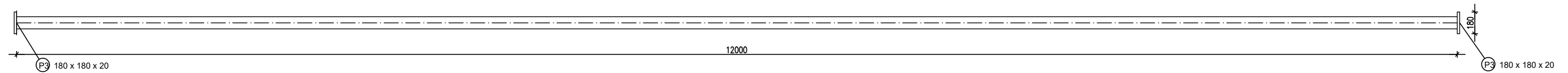
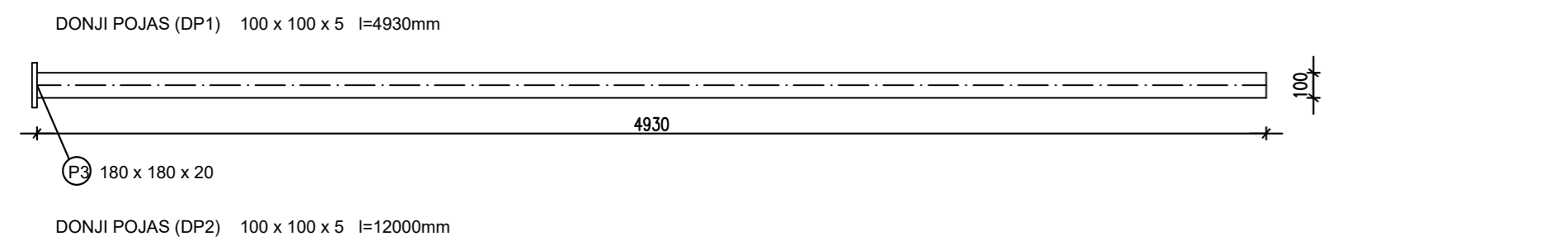
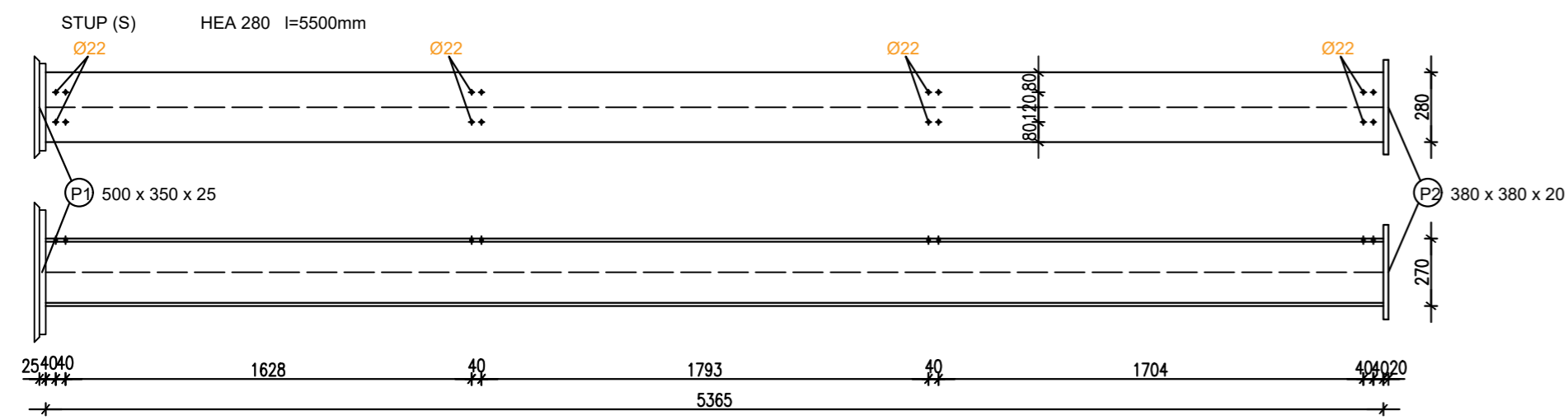

Element	Poprečni presjek	Površina(mm <sup>2</sup> )	Duljina (mm)	Masa (kg/m <sup>3</sup> )	Broj komada	Masa (kg)
S	HEA 280	9730	5365	76,4	22	9017,5
DP1	CFRHS 100/5	1836	4930	14,4	22	1561,8
DP2	CFRHS 100/5	1836	12000	14,4	11	1900,8
GP1	CFRHS 140/7.1	3601	5020	28,3	22	3125,5
GP2	CFRHS 140/7.1	3601	6024	28,3	22	3750,5
V1	CFRHS 140/7.1	3601	1404	28,3	22	874,1
V2	CFRHS 80/40/4	855	1349	6,71	22	199,3
V3	CFRHS 80/40/4	855	1547	6,71	22	228,8
V4	CFRHS 80/40/4	855	1745	6,71	22	258,3
V5	CFRHS 80/40/4	855	1943	6,71	22	286,8
V6	CFRHS 80/40/4	855	2140	6,71	11	158,0
K1	CFRHS 80/40/4	855	2373	6,71	22	350,3
K2	CFRHS 80/40/4	855	2498	6,71	22	369,1
K3	CFRHS 80/40/4	855	2621	6,71	22	386,9
K4	CFRHS 80/40/4	855	2746	6,71	22	406,0
K5	CFRHS 80/40/4	855	2877	6,71	22	424,7
<b>Σ=</b>						<b>23298,4</b>

Svi elementi su klase čelika S355

 Sveučilište u Splitu Fakultet Građevinarstva, Arhitekture i Geodezije 21000 SPLIT, MATICE HRVATSKE 15	<b>ZAVRŠNI RAD</b>	
	ZADATAK: Projektiranje i dimenzioniranje hale	
STUDENT:  Ivan Delaš	SADRŽAJ: Radionički nacrt rešetke i stupa	
	MJERILO: M 1:25	
DATUM: 22.09.2022.		BROJ PRILOGA: 3

# RADIONIČKI NACRT SEKUNDARNIH ELEMENTATA M 1:25



VERTIKALA SPREGA (VS) CFRHS 70 x 70 x 4 l=5400mm

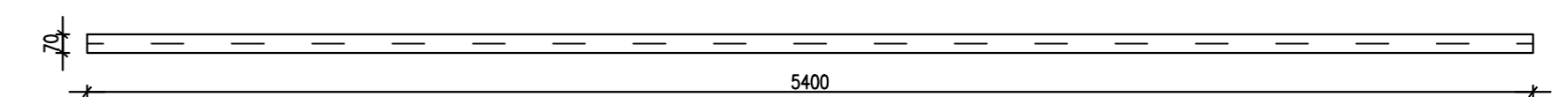

Element	Poprečni presjek	Površina(mm <sup>2</sup> )	Duljina (mm)	Masa (kg/m')	Broj komada	Masa (kg)
Z1	HEA160A	3040	7477	38,23	4	1143,38
Z2	HEA160A	3040	7873	38,23	2	571,69
SK1	RND 14	154	6736	1,21	8	65,20
SK2	RND 14	154	8528	1,21	8	82,55
SB1	RND 14	154	5547	1,21	8	53,69
SB2	RND 14	154	7708	1,21	8	74,61
KP1	IPE 160	2010	12000	15,6	48	8985,6
KP2	IPE 160	2010	6000	15,6	12	1123,2
BP1	IPE 100	1030	12000	8,1	40	3888
BP2	IPE 100	1030	6000	8,1	10	486
VS	CFRHS 70/4	1015	5400	7,97	10	430,38
						Σ= 16904,3

Svi elementi su klase čelika S355

ZAVRŠNI RAD		
 Sveučilište u Splitu Fakultet Građevinarstva, Arhitekture i Geodezije 21000 SPLIT, MATICE HRVATSKE 15	ZADATAK: Projektiranje i dimenzioniranje hale	
	SADRŽAJ: Radionički nacrt sekundarnih elemenata	
STUDENT:  Ivan Delaš	MJERILO: M 1:25	
	DATUM: 22.09.2022.	BROJ PRILOGA: 4

# DETALJ 1

## Spoj STUP-TEMELJ

### M 1:10

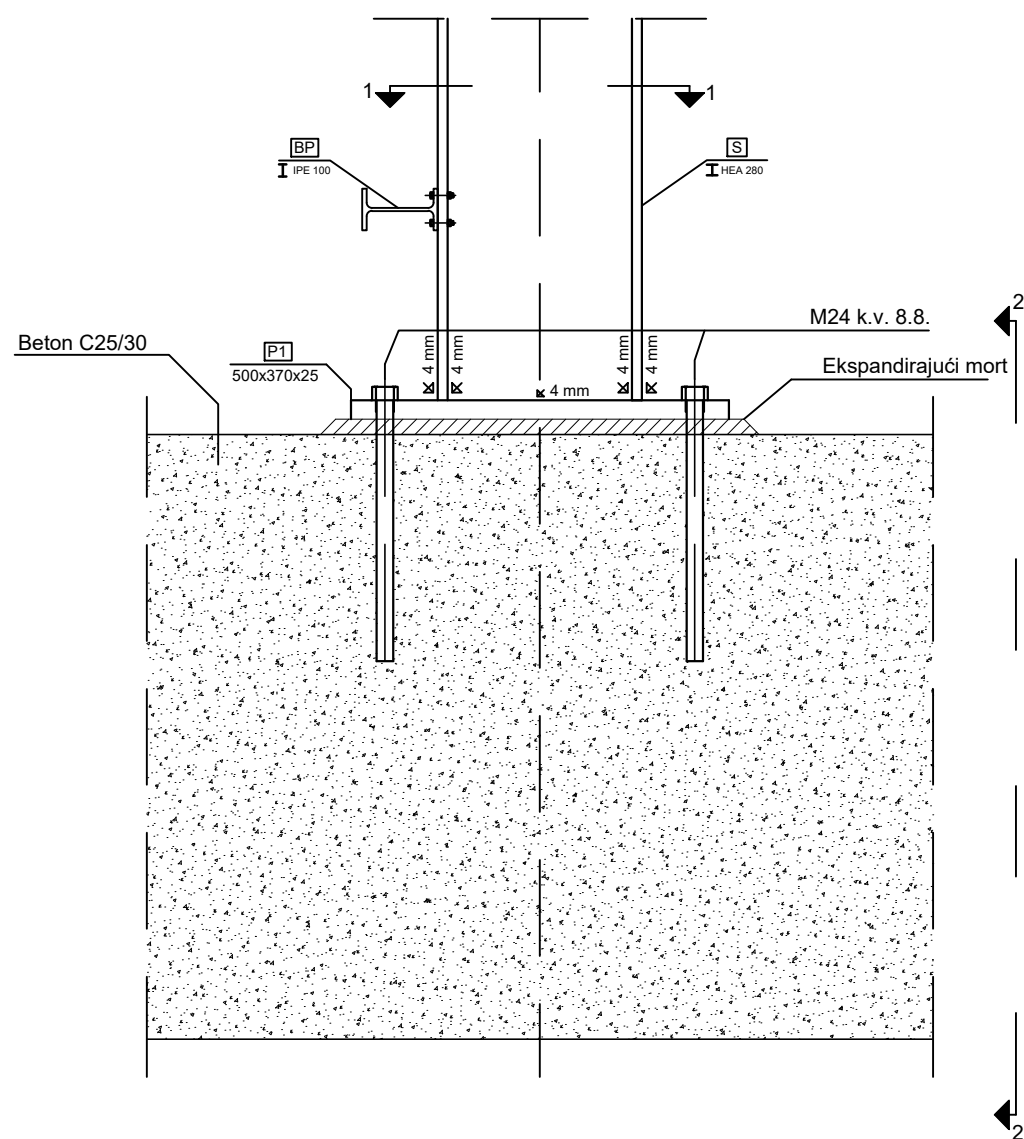

Presjek 1-1

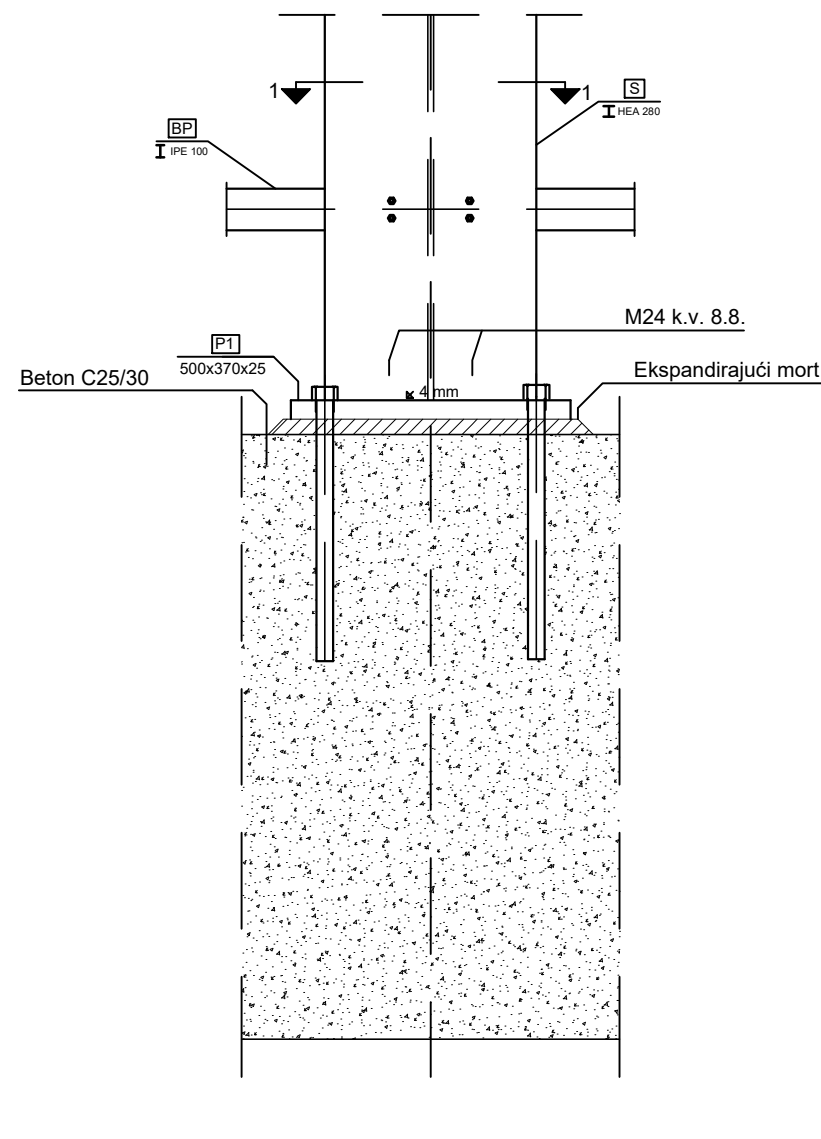

Tlocrt temelja M 1:50

### Pločica

P1 #500x370x25 mm S355 1 kom/spoj

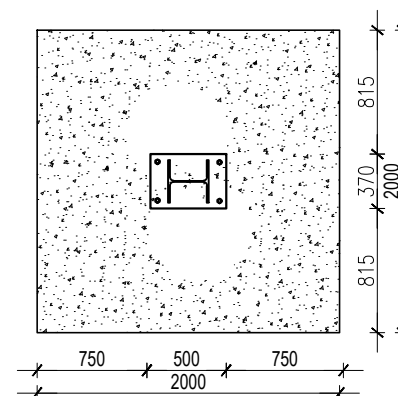
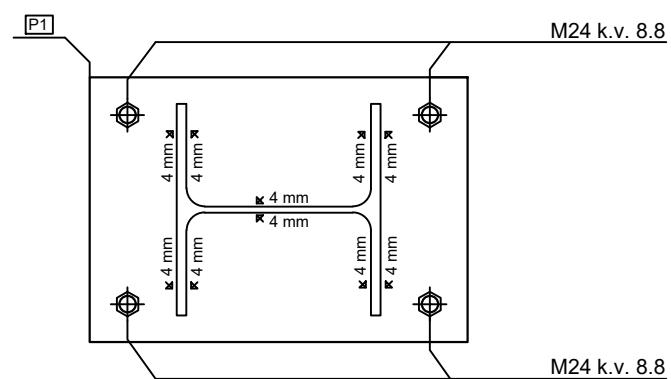
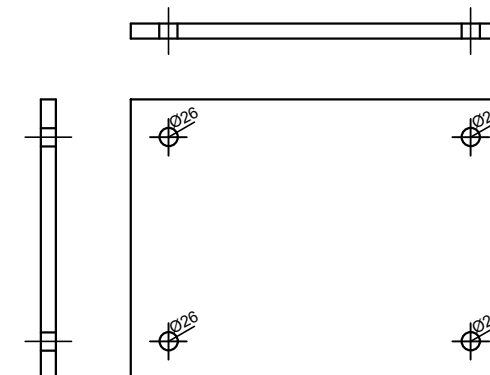

Svi varovi su  $a = 4$  (mm).  
Svi varovi minimalno su kvalitete S355  
Svi elementi su klase čelika S355

 Sveučilište u Splitu Fakultet Građevinarstva, Arhitekture i Geodezije 21000 SPLIT, MATICE HRVATSKE 15	<b>ZAVRŠNI RAD</b>	
	ZADATAK: Projektiranje i dimenzioniranje hale	
STUDENT:  Ivan Delaš	SADRŽAJ: Detalj spoja 1	
	MJERILO: M 1:10	
	DATUM: 22.09.2022.	BROJ PRILOGA: 5

# DETALJ 2

## Spoj VLAČNI NASTAVAK

### M 1:10

### Konstruktivni nastavak GP

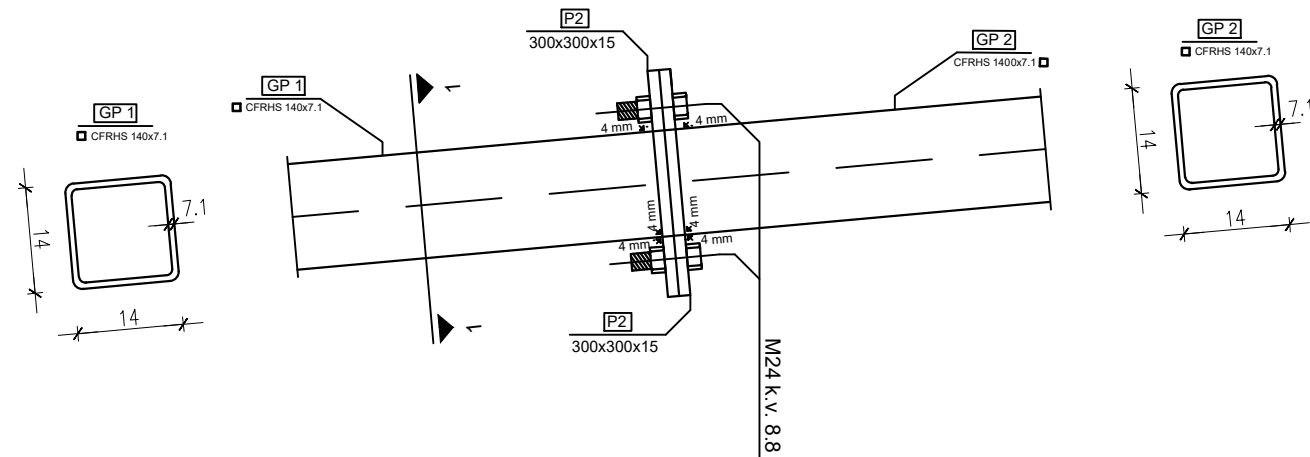

### Vlačni nastavak DP

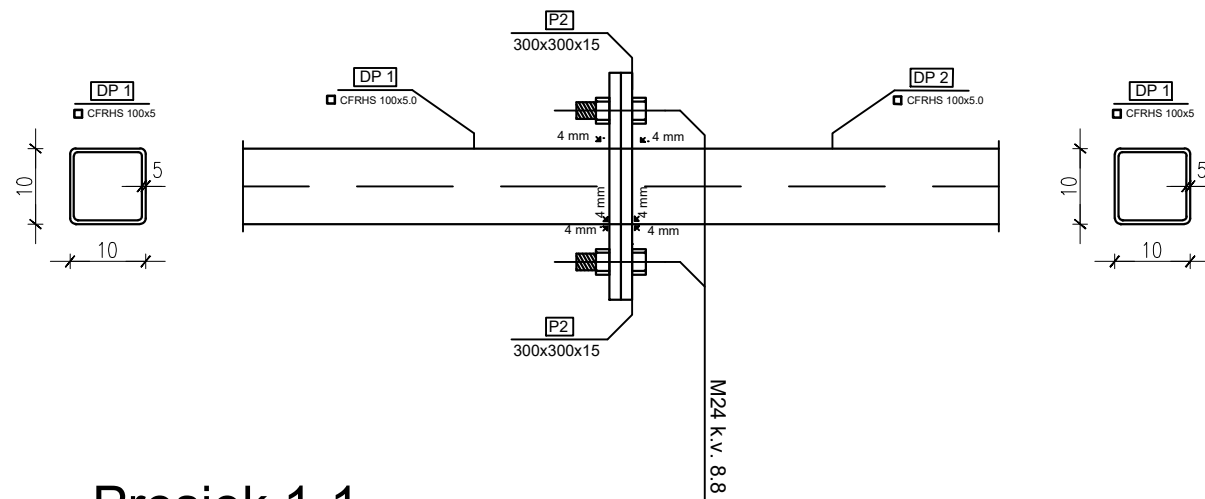

### Presjek 1-1

P2 300x300x15 mm 2 kom/spoj

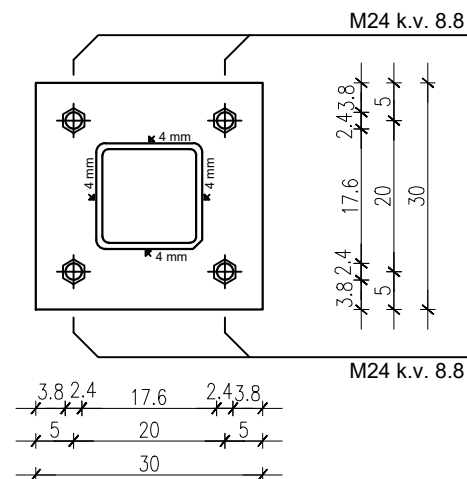

### Pločica

P2 300x300x15 mm 2 kom/spoj

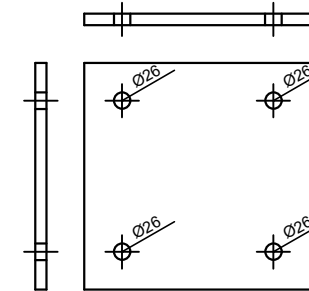

Svi elementi su kvalitete čelika S355

Svi varovi su a= 4 (mm), kvalitete min. S355

 Sveučilište u Splitu Fakultet Građevinarstva, Arhitekture i Geodezije 21000 SPLIT, MATICE HRVATSKE 15	ZAVRŠNI RAD	
	ZADATAK: Projektiranje i dimenzioniranje hale	
	SADRŽAJ: Detalj spoja 2	
	STUDENT:  Ivan Delaš	
MJERILO: M 1:10		BROJ PRILOGA: 6
DATUM: 22.09.2022.		

# DETALJ 3

## Spoj STUP-REŠETKA

### M 1:10

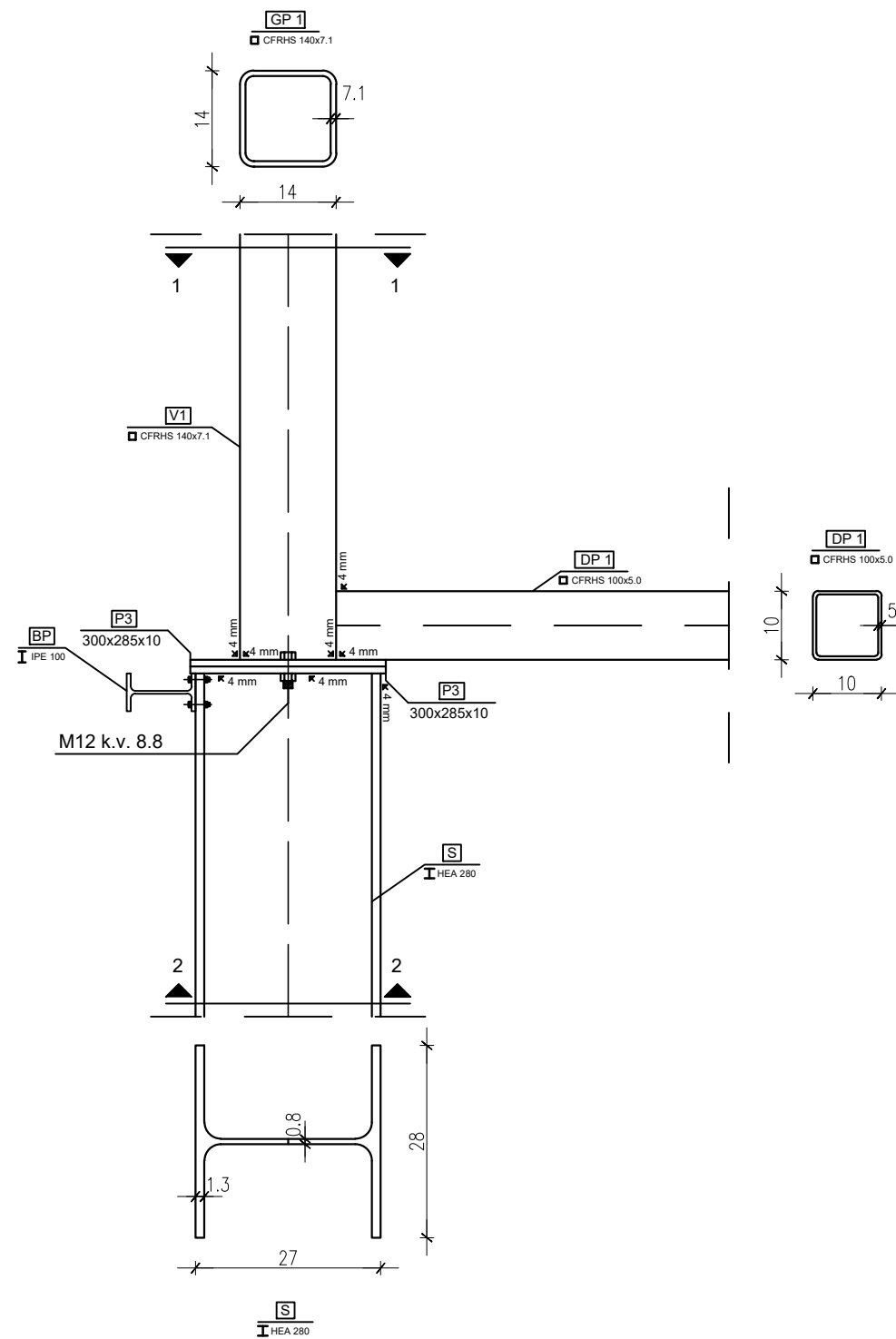

### Pločica

P3 300x285x10 mm 2 kom/spoj

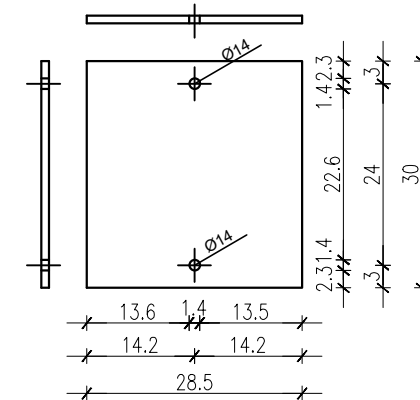

### Presjek 1-1

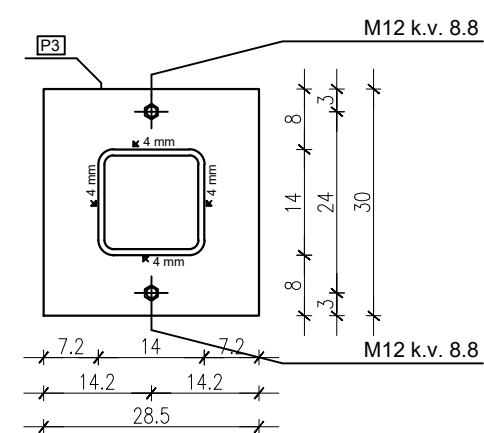

### Presjek 2-2

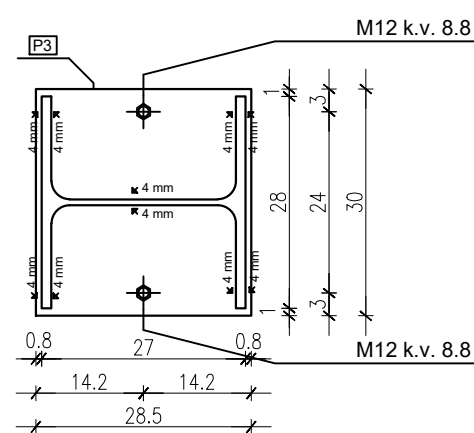

Svi elementi su kvalitete čelika S355

Svi varovi su a= 4 (mm), kvalitete min. S355

 <p>Sveučilište u Splitu Fakultet Građevinarstva, Arhitekture i Geodezije 21000 SPLIT, MATICE HRVATSKE 15</p>	<b>ZAVRŠNI RAD</b>	
	ZADATAK: Projektiranje i dimenzioniranje hale	
	SADRŽAJ: Detalj spoja 3	
	MJERILO: M 1:10	
STUDENT:  Ivan Delaš	DATUM: 22.09.2022.	BROJ PRILOGA: 7

## **9. PREDMJER MATERIJALA ZA CIJELU KONSTRUKCIJU**



## TABLICA PREDMJERA MATERIJALA ZA CIJELU KONSTRUKCIJU

POZICIJA	PROFIL	DUŽINA (mm)	KOMADA	JED. TEŽINA (kg/m)	UKUPNA TEŽINA (kg)
Stup (S)	HEA280	5365	22	76,4	9017,5
Donji pojas (DP1)	CFRHS 100x100x5	4930	22	14,4	1561,8
Donji pojas (DP2)	CFRHS 100x100x5	12000	11	14,4	1900,8
Gornji pojas (GP1)	CFRHS 140x140x7.1	5020	22	28,3	3125,5
Gornji pojas (GP2)	CFRHS 140x140x7.1	6024	22	28,3	3750,5
Vertikala (V1)	CFRHS 140x140x7.1	1404	22	28,3	874,1
Vertikala (V2)	CFRHS 80x40x4	1349	22	6,71	199,3
Vertikala (V3)	CFRHS 80x40x4	1547	22	6,71	228,8
Vertikala (V4)	CFRHS 80x40x4	1745	22	6,71	258,3
Vertikala (V5)	CFRHS 80x40x4	1943	22	6,71	286,8
Vertikala (V6)	CFRHS 80x40x4	2140	11	6,71	158,0
Dijagonala (K1)	CFRHS 80x40x4	2373	22	6,71	350,3
Dijagonala (K2)	CFRHS 80x40x4	2498	22	6,71	369,1
Dijagonala (K3)	CFRHS 80x40x4	2621	22	6,71	386,9
Dijagonala (K4)	CFRHS 80x40x4	2746	22	6,71	406,0
Dijagonala (K5)	CFRHS 80x40x4	2877	22	6,71	424,7
Pločica (P1)	500x370x25	Proračun preko zapremnine	28	7850 (kg/m <sup>3</sup> )	1016,59
Pločica (P2)	300x300x15	Proračun preko zapremnine	88	7850 (kg/m <sup>3</sup> )	932,58
Pločica (P3)	300x285x10	Proračun preko zapremnine	44	7850 (kg/m <sup>3</sup> )	295,32
Zabatni stup(Z1)	HEA160A	7477	4	38,23	1143,38
Zabatni stup(Z2)	HEA160A	7873	2	38,23	571,69
Kr. spreg (KS1)	RND Ø14	6736	8	1,21	65,20
Kr. spreg (KS2)	RND Ø14	8528	8	1,21	82,55
Boč. spreg (BS)	RND Ø14	5547	8	1,21	53,69
Boč. spreg (BS)	RND Ø14	7708	8	1,21	74,61
Krovna podrožnica (KP1)	IPE 160	12000	48	15,6	8985,6
Krovna podrožnica (KP2)	IPE 160	6000	12	15,6	1123,2
Bočna podrožnica (BP1)	IPE 100	12000	40	8,10	3888
Bočna podrožnica (BP2)	IPE 100	6000	10	8,10	486
Vertikala sprega (VS)	CFRHS 70x70x4	5400	10	7,97	430,38
<b>Ukupno (kg) +2,0% spojna sredstva</b>					<b>42447,19 848,94</b>
<b>UKUPNO (kg)</b>					<b>43296,13</b>
<b>UKUPNO (kg/m<sup>2</sup>)</b>					<b>36,44</b>

 Sveučilište u Splitu Fakultet Građevinarstva, Arhitekture i Geodezije 21000 SPLIT, MATICE HRVATSKE 15	<b>ZAVRŠNI RAD</b>	
	ZADATAK: Projektiranje i dimenzioniranje hale	
	SADRŽAJ: Predmjer materijala	
	STUDENT:  Ivan Delaš	MJERILO:
	DATUM: 22.09.2022.	BROJ PRILOGA: 8

## 10. LITERATURA

[1] Prof.dr sc. Ivica Boko: Predavanja

[2] FGAG repozitorij: Repozitorij Fakulteta građevinarstva, arhitekture i geodezije, Sveučilište u Splitu

[3] EN 1991 Eurocode 1

- EN 1991-1-1:2002 Eurocode 1: Actions on structures - Part 1-1: General actions - Densities, self-weight, imposed loads for buildings

-EN 1991-1-3:2003 Eurocode 1: Actions on structures - Part 1-3: General actions - Snow loads

-EN 1991-1-4:2005 Eurocode 1: Actions on structures - Part 1-4: General actions - Wind actions

[4] EN 1992 Eurocode 2

- EN 1992-1-1:2004 Eurocode 2: Design of concrete structures - Part 1-1: General rules and rules for buildings

[5] EN 1993 Eurocode 3

- EN 1993-1-1:2005 Eurocode 3: Design of steel structures - Part 1-1: General rules and rules for buildings

- EN 1993-1-8:2005 Eurocode 3: Design of steel structures - Part 1-8: Design of joints