

Proračun drvene konstrukcije rešetkastog krovišta

Lemo, Antonija

Undergraduate thesis / Završni rad

2024

Degree Grantor / Ustanova koja je dodijelila akademski / stručni stupanj:

University of Split, Faculty of Civil Engineering, Architecture and Geodesy / Sveučilište u Splitu, Fakultet građevinarstva, arhitekture i geodezije

Permanent link / Trajna poveznica: <https://um.nsk.hr/um:nbn:hr:123:856310>

Rights / Prava: [In copyright](#)/[Zaštićeno autorskim pravom.](#)

Download date / Datum preuzimanja: **2025-01-11**



Repository / Repozitorij:

[FCEAG Repository - Repository of the Faculty of Civil Engineering, Architecture and Geodesy, University of Split](#)



UNIVERSITY OF SPLIT



**SVEUČILIŠTE U SPLITU
FAKULTET GRAĐEVINARSTVA, ARHITEKTURE I GEODEZIJE**

ZAVRŠNI RAD

Antonija Lemo

Split, 2024.

**SVEUČILIŠTE U SPLITU
FAKULTET GRAĐEVINARSTVA, ARHITEKTURE I GEODEZIJE**

Antonija Lemo

**PRORAČUN DRVENE KONSTRUKCIJE
REŠETKASTOG KROVIŠTA**

Završni rad

Split, 2024.

Sadržaj

1. TEHNIČKI OPIS	1
1.1 KONSTRUKTIVNI SUSTAV KROVA	1
1.2 STATIČKA ANALIZA SUSTAVA	1
1.3 OPIS KONSTRUKTIVNIH ELEMENATA	1
1.3.1 <i>Glavni nosači</i>	1
1.3.2 <i>Podrožnice</i>	1
1.3.3 <i>Spreg</i>	1
1.4 MATERIJALI	2
1.4.1 <i>Drveni materijali</i>	2
1.4.2 <i>Metalni elementi</i>	2
1.5 ZAŠTITA	2
1.5.1 <i>Zaštita drvenih elemenata</i>	2
1.5.2 <i>Zaštita metalnih elemenata</i>	2
1.6 MONTAŽA I TRANSPORT	2
2. ANALIZA OPTEREĆENJA	3
2.1 STALNO OPTEREĆENJE	3
2.1.1 <i>Krovna ploha</i>	3
2.2 PROMIENJIVO OPTEREĆENJE	3
2.2.1 <i>Opterećenje snijegom</i>	3
2.2.2 <i>Opterećenje vjetrom</i>	4
3. STATIČKI PRORAČUN	8
3.1 OPTEREĆENJA ČVOROVA I PRIKAZ REZNIH SILA	8
3.1.1 <i>2. proračunska kombinacija</i>	8
3.2 KONTROLA PROGIBA	9
3.2.1 <i>Stalno opterećenje (G)</i>	9
3.2.2 <i>Promjenjivo opterećenje- snijeg (Q)</i>	9
3.2.3 <i>Promjenjivo opterećenje vjetar (Q)</i>	10
4. DIMENZIONIRANJE	11
4.1 GORNJI POJAS	12
4.2 DONJI POJAS	14
4.3 DIJAGONALE	15
4.4 VERTIKALE	17
4.5 PODROŽNICE	18
5. STABILIZACIJA	19
5.1 DOKAZ ZA GORNJI POJAS GLAVNOG NOSAČA (POJASEVI SPREGA)	21
5.2 DOKAZ ZA PODROŽNICE (VERTIKALE SPREGA)	22
5.3 DOKAZ ZA DIJAGONALE	23
6. PRORAČUN SPAJALA	24
6.1 PRORAČUN VLAČNOG NASTAVKA DONJEG POJASA	24
6.2 DETALJ 2- DVOSTRUKI ZASJEK	27
6.3 DETALJ 3- JEDNOSTRUKI ZASJEK I BUŠENI ČAVLI	29
6.4 DETALJ 4- BUŠENI ČAVLI	31
6.5 DETALJ 5- JEDNOSTRUKI ZASJEK I TIJESNO UGRAĐENI VIJCI	33
6.6 DETALJ 6- JEDNOSTRUKI ZASJEK I TIJESNO UGRAĐENI VIJCI	36
6.7 DETALJ 7- TIJESNO UGRAĐENI VIJCI	39
6.8 DETALJ 8- JEDNOSTRUKI ZASJEK I TIJESNO UGRAĐENI VIJCI	41
7. VATROOTPORNOST ELEMENATA	44

7.1	VATROOTPORNOST GORNJEG POJASA	45
7.2	VATROOTPORNOST DONJEG POJASA	47
7.3	VATROOTPORNOST DIJAGONALA	49
7.4	VATROOTPORNOST VERTIKALA	51
7.5	DOKAZ ZA DIJAGONALE	53
8.	VATROOTPORNOST SPOJEVA	55
8.1	VATROOTPORNOST DETALJA 1	55
8.2	VATROOTPORNOST DETALJA 2	56
8.3	VATROOTPORNOST DETALJA 3	57
8.4	VATROOTPORNOST DETALJA 4	59
8.5	VATROOTPORNOST DETALJA 5	60
8.6	VATROOTPORNOST DETALJA 6	61
8.7	VATROOTPORNOST DETALJA 7	62
8.8	VATROOTPORNOST DETALJA 8	63
9.	NACRTI	64
1.	GENERALNI PLAN POZICIJA (M 1:100)	64
2.	RADIONIČKI NACRT GLAVNOG NOSAČA (M 1:25)	64
3.	DETALJ 1 (M 1:10)	64
4.	DETALJ 2 (M 1:10)	64
5.	DETALJ 3 (M 1:10)	64
6.	DETALJ 4 (M 1:10)	64
7.	DETALJ 5 (M 1:10)	64
8.	DETALJ 6 (M 1:10)	64
9.	DETALJ 7 (M 1:10)	64
10.	DETALJ 8 (M 1:10)	64



PRIJEDIPLOMSKI STUDIJ GRAĐEVINARSTVO
KOLEGIJ: OSNOVE DRVENIH KONSTRUKCIJA

ZADATAK ZA ZAVRŠNI RAD

Potrebno je konstruirati i dimenzionirati nosivi sustav krovne konstrukcije prema skici.

POPREČNI PRESJEK

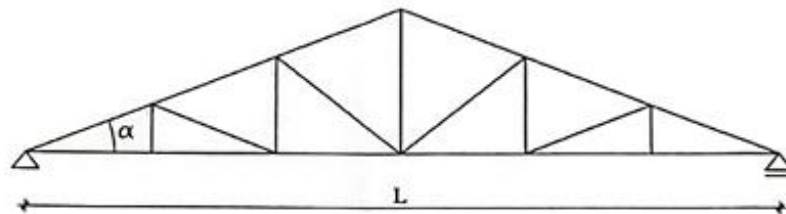

TLOCRT

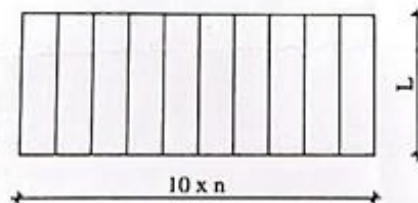

ZADANI PODACI

- Raspon rešetke:	L = 20.6 m
- Razmak okvira:	n = 4.5 m
- Nagib krovne plohe:	17°
- Materijal izrade:	C30
- Uporabna klasa:	2
- Lokacija objekta:	Zagreb
- Kat. zemljišta:	3

STUDENT/ICA: Antonija Lemo

Potrebno je izvršiti dimenzioniranje nosive konstrukcije na slici odnosno izvršiti kontrolu graničnog stanja nosivosti i graničnog stanja uporabljivosti konstrukcije prema EC5. Potrebno je napraviti dodatnu analizu nosive konstrukcije kako slijedi:

- dimenzioniranje svih spojeva nosive konstrukcije prema EC5,
- proračun nosivosti konstrukcije uslijed djelovanja požara u trajanju od 30 min prema EC5,
- proračun nosivosti spojeva konstrukcije uslijed djelovanja požara u trajanju od 30 min prema EC5.

Izv.prof.dr.sc. Neno Torić / Split, 22.03.2024.

PRORAČUN DRVENE KONSTRUKCIJE REŠETKASTOG KROVIŠTA

Sažetak:

Izveden je proračun drvene konstrukcije rešetkastog nosača koji ima dimenzije 20.6 x 45 m. Drvena konstrukcija smještena je u Zagrebu. Cijeli proračun obuhvaća proračun promjenjivih i stalnih opterećenja, dimenzioniranje elemenata i spojeva. Također uključuje i vatrootpornost cijele konstrukcije i spojeva u trajanju od 30 minuta. Izrađeni su i nacrti za svaki navedeni proračun.

Ključne riječi:

Drvena konstrukcija, rešetkasto krovšte, dimenzioniranje elemenata, dimenzioniranje spojeva, vatrootpornost

CALCULATION OF THE WOODEN STRUCTURE OF THE LATTICE ROOF

Abstract:

The calculation of wooden structure of the lattice roof with dimension 20.6 x 45 m. The construction is located in Zagreb. The whole calculation includes constant and variable loads, dimensioned elements and connections. The fire resistance of the structure and the fire of resistance of connections for a duration of 30 minutes was proven. Drawings and details are made for every calculation.

Keywords:

Wooden construction, the lattice roof, dimensioned elements, dimensioned connections, fire resistance

1. Tehnički opis

1.1 Konstruktivni sustav krova

Konstruktivni sustav je drveni rešetkasti nosač raspona $L = 20,6$ m. Visina nosača u tjemenu iznosi $h = 3,15$ m. Krovna ploha je nagnuta pod kutom $\alpha = 17^\circ$ u odnosu na horizontalnu ravninu. Glavni nosači konstrukcije su paralelni i nalaze se na međusobnom razmaku $n = 4,5$ m. Horizontalnim spregom konstrukcija je stabilizirana. Ukupna dužina same konstrukcije iznosi $45,0$ m.

1.2 Statička analiza sustava

Proračun je izvršen prema EUROCODU 5. Konstrukcija je izložena djelovanju vlastite težine, vjetra i snijega. Građevina se nalazi na području Zagreba, kategorija zemljišta 3.

Odgovarajući koeficijenti za vjetar i snijeg uzeti su prema tome iz propisanih tablica.

Za statički proračun upotrijebljena je kombinacija s najvećim utjecajem, dakle vlastita težina konstrukcije + djelovanje snijega + djelovanje vjetra i vlastita težina konstrukcije + djelovanje vjetra.

Proračun reznih sila je napravljen pomoću programa Scia Engineer i to tako da su umetnuti zglobovi na mjestima spajanja vertikala i dijagonala s gornjim i donjim pojasom. Ovakav model za proračun daje približan i dovoljno točan rezultat.

Izvršena je analiza bočnog opterećenja u kombinaciji s vjetrom koji djeluje okomito na glavni nosač i izbočava ga. Cilj ovog proračuna je prostorna stabilizacija konstrukcije.

1.3 Opis konstruktivnih elemenata

1.3.1 Glavni nosači

Glavni nosači predstavljaju nosivi dio konstrukcije i prenose vertikalna opterećenja na nosive zidove i dalje na temeljno tlo. Dimenzionirani su da prime utjecaj od vlastite težine i opterećenja od snijega i vjetra. Oni su pravokutnog poprečnog presjeka.

1.3.2 Podrožnice

Podrožnica prenosi opterećenje s krovne plohe na glavne nosače. Elementi podrožnice koji imaju i funkciju vertikala vjetrovnog sprega, kvadratnog su poprečnog presjeka dimenzija 18 cm x 20 cm i nalaze se na razmaku $1,795$ m.

1.3.3 Spreg

Spreg služi za prihvaćanje horizontalnih sila i za pridržavanje glavnih nosača da ne bi došlo do izbočavanja. Horizontalne spregove tvore glavni nosači kao pojasevi, glavne podrožnice kao vertikale i dijagonale koje su izvedene od čelika S235 okruglog poprečnog presjeka M 10.

1.4 Materijali

1.4.1 Drveni materijali

Drveni elementi konstrukcije izrađeni su od drva klase C30. Karakteristične vrijednosti čvrstoća, modula i gustoće za ovu klasu:

$$f_{m,k} = 30 \text{ N/mm}^2$$

$$f_{t,0,k} = 19 \text{ N/mm}^2$$

$$f_{c,0,k} = 24 \text{ N/mm}^2$$

$$f_{v,k} = 4 \text{ N/mm}^2$$

$$E_{o,mean} = 12000 \text{ N/mm}^2$$

$$G_{mean} = 750 \text{ N/mm}^2$$

$$q = 380 \text{ kg/m}^3$$

1.4.2 Metalni elementi

Za spajanje pojedinih elemenata upotrijebljeni su tijesno ugrađeni vijci Φ 16mm (M16) kl. čvrstoće 4,8. Materijal izrade vijaka ima vlačnu čvrstoću 400 N/mm². Osim toga korišteni su i bušeni čavli 6/180mm koji imaju vlačnu čvrstoću 600 N/mm². Pokrov je izveden od sendvič panela (aluminij).

1.5 Zaštita

1.5.1 Zaštita drvenih elemenata

Zaštita nosivih elemenata se vrši pokrivnim premazima za zaštitu od prodora vode i nametnika.

1.5.2 Zaštita metalnih elemenata

Ugrađuju se samo pocinčani metalni elementi i spajala.

1.6 Montaža i transport

Transport i montažu potrebno je obaviti tako da se izbjegnju oštećenja elemenata konstrukcije. Glavni nosači se izrađuju na podu, onda se dizalicom podižu u vertikalni položaj.

Nosači se trebaju transportirati u onom položaju u kojem će kasnije biti opterećeni.

2. Analiza opterećenja

2.1 Stalno opterećenje

2.1.1 Krovna ploha

- sendvič paneli (aluminij) $0,25 \text{ kN/m}^2$
 - sekundarna konstrukcija i spregovi + instalacije $0,25 \text{ kN/m}^2$
- $\Sigma = 0,50 \text{ kN/m}^2$
- vlastita težina automatski je uključena u računalni program
- $G_k = (\Delta g + 0,25) * n * a = 0,50 \text{ kN/m}^2 * 4,5 \text{ m} * 1,795 \text{ m} = 4,039 \text{ kN}$

2.2 Promjenjivo opterećenje

2.2.1 Opterećenje snijegom

Opterećenje snijegom na krovu (po tlocrtnoj površini krova) određuje se po formuli:

$$s_k = \mu_i * c_e * c_t * s \text{ (kN/m}^2\text{)}$$

$s_k \Rightarrow$ karakteristična vrijednost opterećenja na tlu u kN/m^2

$s = 1,0 \text{ kN/m}^2 \Leftrightarrow$ za Zagreb, do 100m nadmorske visine

$\mu_i \Rightarrow$ koeficijent oblika za opterećenje snijegom, očitamo ga ovisno o obliku i nagibu krova

$15^\circ < \alpha = 17^\circ \leq 30^\circ \Rightarrow \mu_i = 0,8$

$c_e \Rightarrow$ koeficijent izloženosti

$c_e = 1,0$

$c_t \Rightarrow$ toplinski koeficijent

$c_t = 1,0$

Opterećenje snijegom preko cijele krovne površine:

$$s_k = 0,80 * 1,0 * 1,0 * 1,25 = 1,00 \text{ (kN/m}^2\text{)}$$

$$S_k = s_k * n * a$$

$$S_k = 1,00 \text{ (kN/m}^2\text{)} * 4,5 \text{ m} * 1,795 \text{ m} = 8,08 \text{ kN}$$

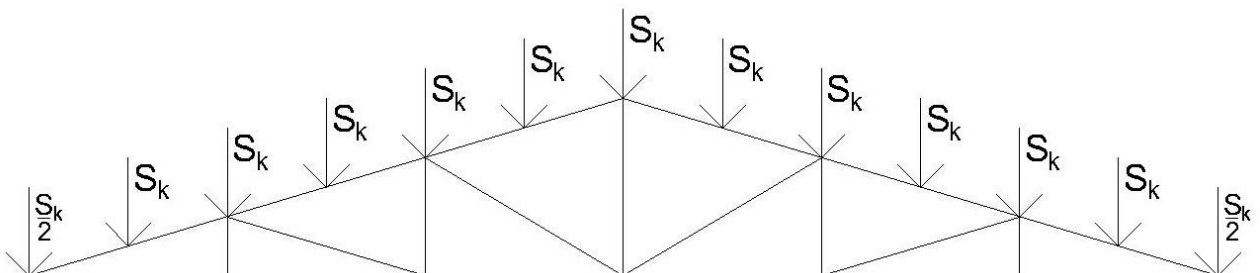

2.2.2 Opterećenje vjetrom

Opterećenje vjetrom okomito na površinu.

$w_e = q_p(z) * c_e(z_e) * c_{pe}$ (kN/m²) – pritisak vjetra na vanjske površine

$w_i = q_p(z) * c_i(z_i) * c_{pi}$ (kN/m²) – pritisak vjetra na unutarne površine

$c_e(z_e), c_i(z_i) \Rightarrow$ koeficijenti izloženosti koji uzimaju u obzir neravnine terena

Određivanje osnovnog pritiska brzine vjetra pri udaru:

$$q_b = \frac{1}{2} * \rho * v_b^2$$

q_b = referentni pritisak srednje brzine vjetra

$\rho \Rightarrow$ gustoća zraka, $\rho = 1.25 \text{ kg/m}^3$

v_b - osnovna brzina vjetra $v_b = 25 \text{ (m/s)}$

$$q_b = \frac{1}{2} * 1,25 * 25^2$$

$$q_b = 390,625 \left(\frac{N}{m^2} \right) = 0,39 \left(\frac{kN}{m^2} \right)$$

Određivanje pritiska brzine vjetra pri udaru:

$$q_p(z) = C_e * q_b$$

$C_e = 1,7$ (očitano)

$$q_p(z) = 3,0 * 0,39 = 0,66 \left(\frac{kN}{m^2} \right)$$

Unutarnji vjetar:

$C_{pi1} = + 0,2$

$C_{pi2} = - 0,3$

$W_{k,i(+)} = 0,2 * 0,66 = 0,132 \text{ kN/m}^2$

$W_{k,i(-)} = 0,3 * 0,66 = 0,198 \text{ kN/m}^2$

C_{pe10}		C_{pe10}	
	$H(15^\circ) = - 0,3$		$H(15^\circ) = 0,2$
	<u>$H(30^\circ) = - 0,2$</u>		<u>$H(30^\circ) = 0,4$</u>
$G(15^\circ) = - 0,8$	$H(17^\circ) = -$	$G(15^\circ) = 0,2$	$H(17^\circ) =$
<u>$G(30^\circ) = - 0,5$</u>	$0,287$	<u>$G(30^\circ) = 0,7$</u>	$0,227$
$G(17^\circ) = -$		$G(17^\circ) =$	
$0,76$	$I(15^\circ) = - 0,4$	$0,267$	$I(15^\circ) = 0,0$
	<u>$I(30^\circ) = - 0,4$</u>		<u>$I(30^\circ) = 0,0$</u>
	$I(17^\circ) = - 0,4$		$I(17^\circ) = 0,0$
	$J(15^\circ) = - 1,0$		$J(15^\circ) = 0,0$
	<u>$J(30^\circ) = - 0,5$</u>		<u>$J(30^\circ) = 0,0$</u>
	$J(17^\circ) = -$		$J(17^\circ) = 0,0$
	$0,93$		

Vanjski negativni(-)	Vanjski pozitivni(+)
----------------------	----------------------

$W_{k,e,G} = 0,66 \cdot 0,76 = 0,502$	$W_{k,e,G} = 0,66 \cdot 0,267 = 0,176$
$W_{k,e,H} = 0,66 \cdot 0,287 = 0,189$	$W_{k,e,H} = 0,66 \cdot 0,227 = 0,15$
$W_{k,e,J} = 0,66 \cdot 0,993 = 0,616$	$W_{k,e,J} = 0,66 \cdot 0 = 0$
$W_{k,e,I} = 0,66 \cdot 0,4 = 0,264$	$W_{k,e,I} = 0,66 \cdot 0 = 0$

KOMBINACIJA:

PRITISKAJUĆI	ODIŽUĆI
$W_p^G = 0,176 + 0,198 = 0,374 \text{ kN/m}^2$	$W_o^G = 0,502 + 0,132 = 0,634 \text{ kN/m}^2$
$W_p^H = 0,15 + 0,198 = 0,348 \text{ kN/m}^2$	$W_o^H = 0,189 + 0,132 = 0,321 \text{ kN/m}^2$
$W_p^J = 0 + 0,198 = 0,198 \text{ kN/m}^2$	$W_o^J = 0,616 + 0,132 = 0,748 \text{ kN/m}^2$
$W_p^I = 0 + 0,198 = 0,198 \text{ kN/m}^2$	$W_o^I = 0,264 + 0,132 = 0,396 \text{ kN/m}^2$

KONCENTRIRANE SILE ZA PRITISKAJUĆI VJETAR

$$W_1 = w_p^G \cdot n \cdot a/2 = 0,374 \cdot 4,5 \cdot 1,795/2 = 1,51 \text{ kN}$$

$$W_2 = w_p^G \cdot n \cdot 1,10 + w_p^H \cdot n \cdot 0,695 = \\ = 0,374 \cdot 4,5 \cdot 1,10 + 0,348 \cdot 4,5 \cdot 0,695 = 2,94 \text{ kN}$$

$$W_3 = w_p^H \cdot n \cdot a = 0,348 \cdot 4,5 \cdot 1,795 = 2,811 \text{ kN}$$

$$W_4 = w_p^H \cdot n \cdot a = 0,348 \cdot 4,5 \cdot 1,795 = 2,811 \text{ kN}$$

$$W_5 = w_p^H \cdot n \cdot a = 0,348 \cdot 4,5 \cdot 1,795 = 2,811 \text{ kN}$$

$$W_6 = w_p^H \cdot n \cdot a = 0,348 \cdot 4,5 \cdot 1,795 = 2,811 \text{ kN}$$

$$W_7 = w_p^H \cdot n \cdot a/2 = 0,348 \cdot 4,5 \cdot 1,795/2 = 1,405 \text{ kN}$$

$$W_8 = w_p^l \cdot n \cdot a/2 = 0,198 \cdot 4,5 \cdot 1,795/2 = 0,8 \text{ kN}$$

$$W_9 = w_p^l \cdot n \cdot 1,1 + w_p^l \cdot n \cdot 0,695 = \\ = 0,198 \cdot 4,5 \cdot 1,1 + 0,198 \cdot 4,5 \cdot 0,695 = 1,6 \text{ kN}$$

$$W_{10} = w_p^l \cdot n \cdot a = 0,198 \cdot 4,5 \cdot 1,795 = 1,6 \text{ kN}$$

$$W_{11} = w_p^l \cdot n \cdot a = 0,198 \cdot 4,5 \cdot 1,795 = 1,6 \text{ kN}$$

$$W_{12} = w_p^l \cdot n \cdot a = 0,198 \cdot 4,5 \cdot 1,795 = 1,6 \text{ kN}$$

$$W_{13} = w_p^l \cdot n \cdot a = 0,198 \cdot 4,5 \cdot 1,795 = 1,6 \text{ kN}$$

$$W_{14} = w_p^l \cdot n \cdot a/2 = 0,198 \cdot 4,5 \cdot 1,795/2 = 0,8 \text{ kN}$$

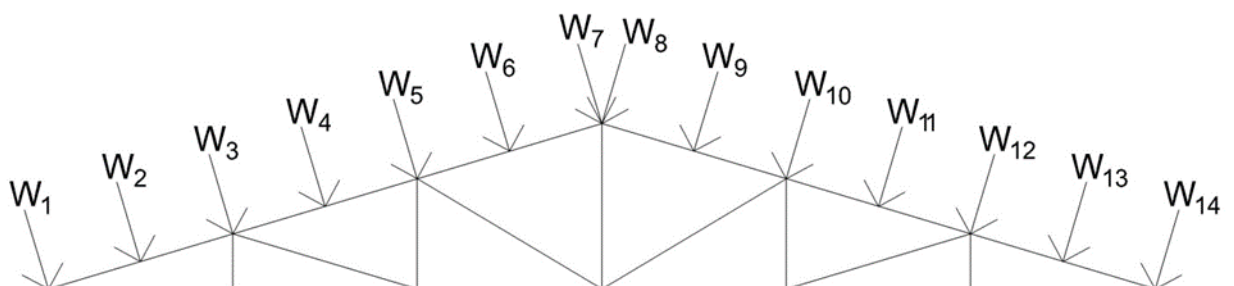

KONCENTRIRANE SILE ZA ODIŽUĆI VJETAR

$$W_1 = w_o^G \cdot n \cdot a/2 = 0,634 \cdot 4,5 \cdot 1,795/2 = 2,561 \text{ kN}$$

$$W_2 = w_o^G \cdot n \cdot 1,10 + w_o^H \cdot n \cdot 0,695 = \\ = 0,634 \cdot 4,5 \cdot 1,10 + 0,321 \cdot 4,5 \cdot 0,695 = 4,142 \text{ kN}$$

$$W_3 = w_o^H \cdot n \cdot a = 0,321 \cdot 4,5 \cdot 1,795 = 2,593 \text{ kN}$$

$$W_4 = w_o^H \cdot n \cdot a = 0,321 \cdot 4,5 \cdot 1,795 = 2,593 \text{ kN}$$

$$W_5 = w_o^H \cdot n \cdot a = 0,321 \cdot 4,5 \cdot 1,795 = 2,593 \text{ kN}$$

$$W_6 = w_o^H \cdot n \cdot a = 0,321 \cdot 4,5 \cdot 1,795 = 2,593 \text{ kN}$$

$$W_7 = w_o^H \cdot n \cdot a/2 = 0,321 \cdot 4,5 \cdot 1,795/2 = 1,296 \text{ kN}$$

$$W_8 = w_o^J \cdot n \cdot a/2 = 0,748 \cdot 4,5 \cdot 1,795/2 = 3,02 \text{ kN}$$

$$W_9 = w_o^J \cdot n \cdot 1,1 + w_o^I \cdot n \cdot 0,695 = \\ = 0,748 \cdot 4,5 \cdot 1,1 + 0,369 \cdot 4,5 \cdot 0,695 = 4,941 \text{ kN}$$

$$W_{10} = w_o^I \cdot n \cdot a = 0,396 \cdot 4,5 \cdot 1,795 = 1,6 \text{ kN}$$

$$W_{11} = w_o^I \cdot n \cdot a = 0,396 \cdot 4,5 \cdot 1,795 = 1,6 \text{ kN}$$

$$W_{12} = w_o^I \cdot n \cdot a = 0,369 \cdot 4,5 \cdot 1,795 = 1,6 \text{ kN}$$

$$W_{13} = w_o^I \cdot n \cdot a = 0,396 \cdot 4,5 \cdot 1,795 = 1,6 \text{ kN}$$

$$W_{14} = w_o^I \cdot n \cdot a/2 = 0,396 \cdot 4,5 \cdot 1,795/2 = 0,355 \text{ kN}$$

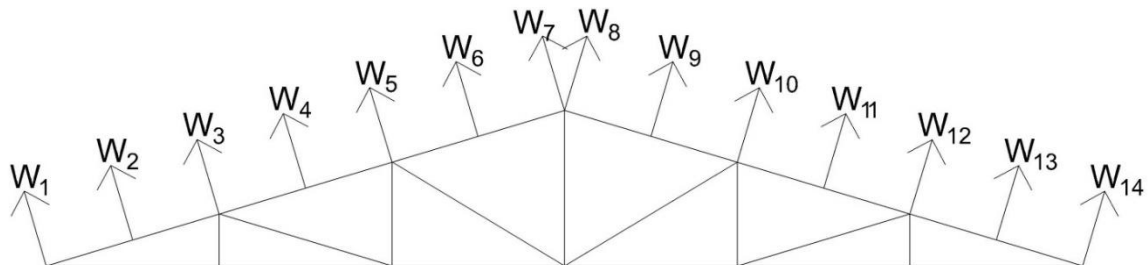

3. Statički proračun

3.1 Opterećenja čvorova i prikaz reznih sila

3.1.1 2. proračunska kombinacija

$$1,35 * G + 1,50 * 0,9 * (Wp+S)$$

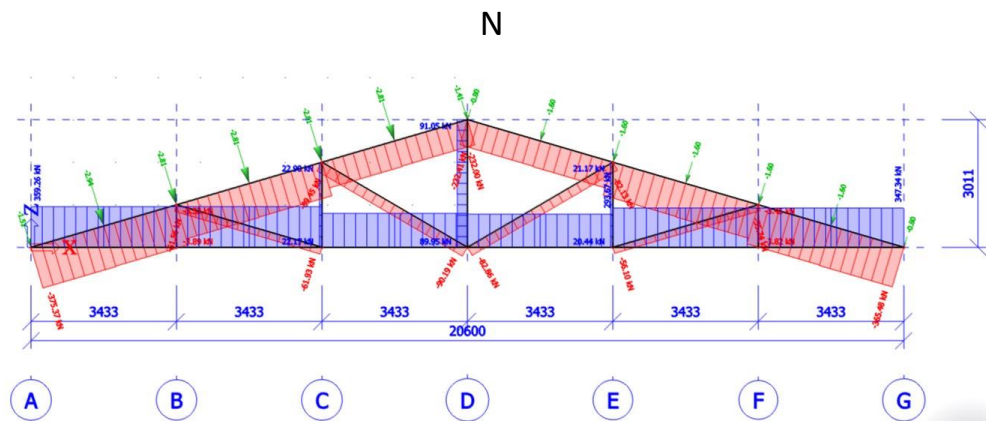
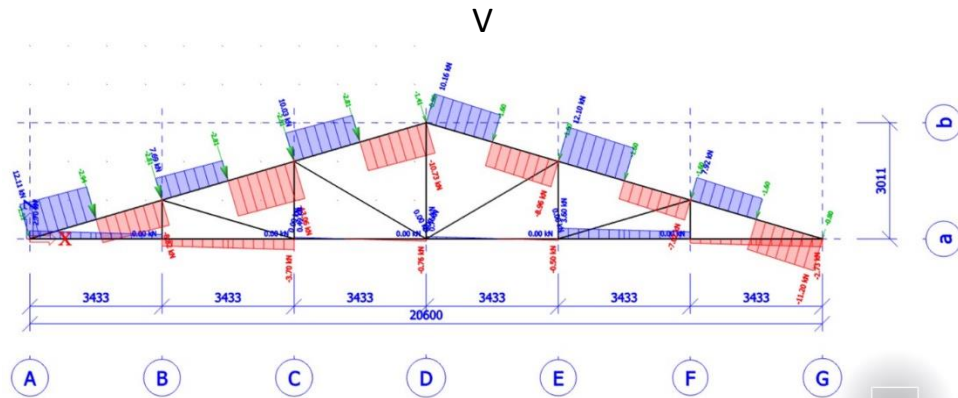
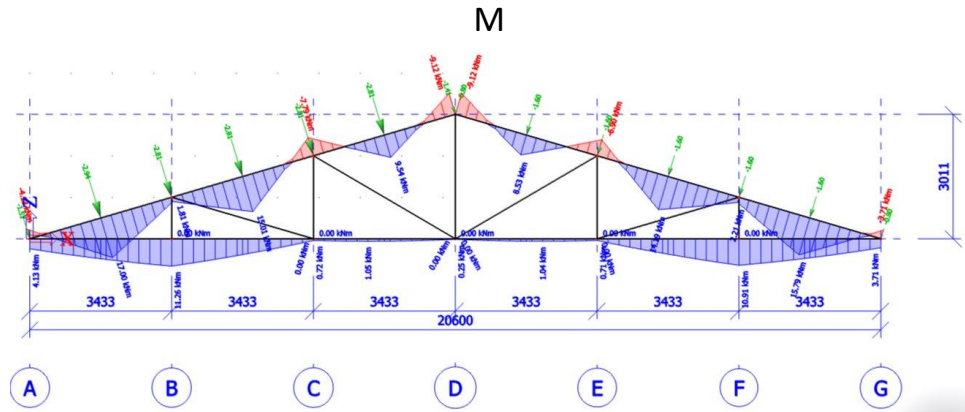

3.2 Kontrola progiba

3.2.1 Stalno opterećenje (G)

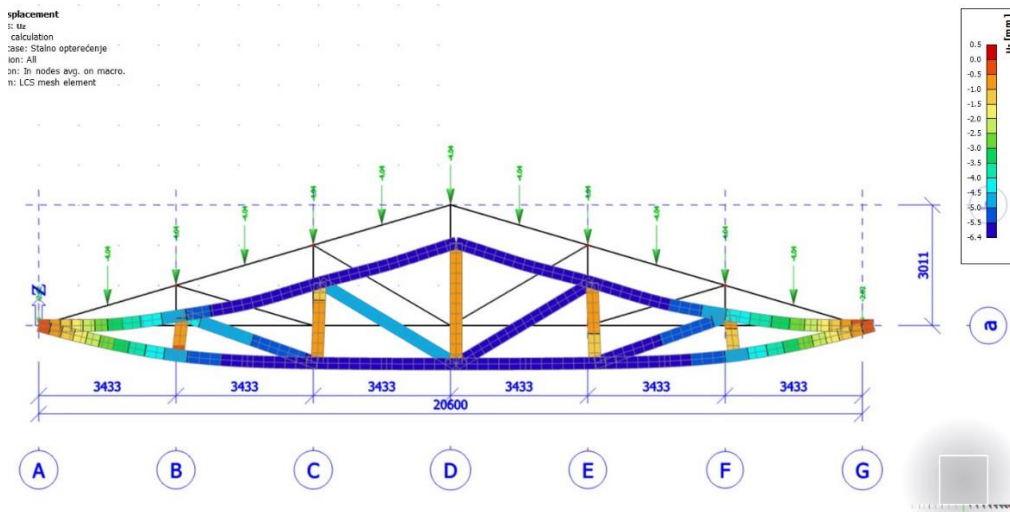

$$u_{G,inst}=0,89 \text{ cm}$$

$$\begin{aligned} u_{G,fin} &= u_{G,inst}(1+k_{def,G}) \\ &= 0,89*(1+0,8) \\ &= 1,602 \text{ cm} \end{aligned}$$

3.2.2 Promjenjivo opterećenje- snijeg (Q)

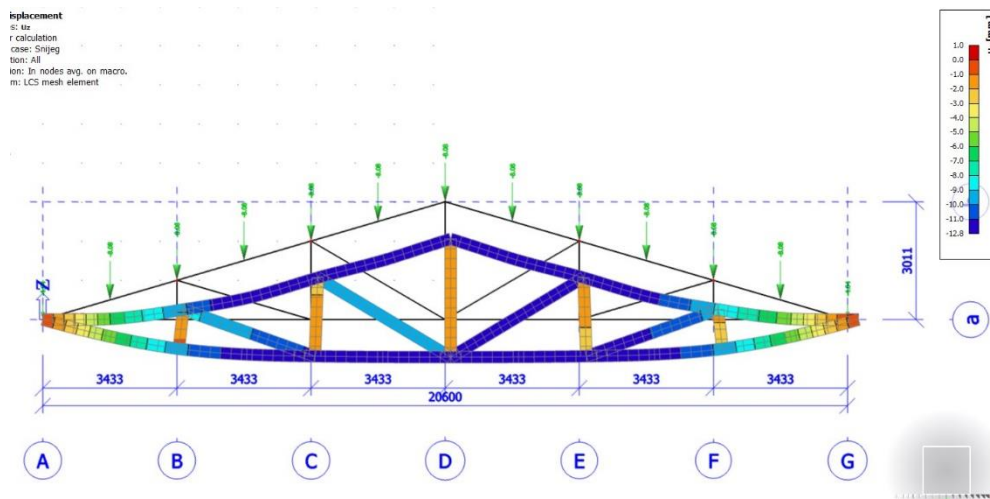

$$u_{Q,inst}=1,28 \text{ cm}$$

$$\begin{aligned} u_{Q,fin} &= u_{Q,inst}(1+\Psi_2 \times k_{def}) \\ &= 1,28*(1+0 \times 0,8) \\ &= 1,28 \text{ cm} \end{aligned}$$

3.2.3 Promjenjivo opterećenje vjetar (Q)

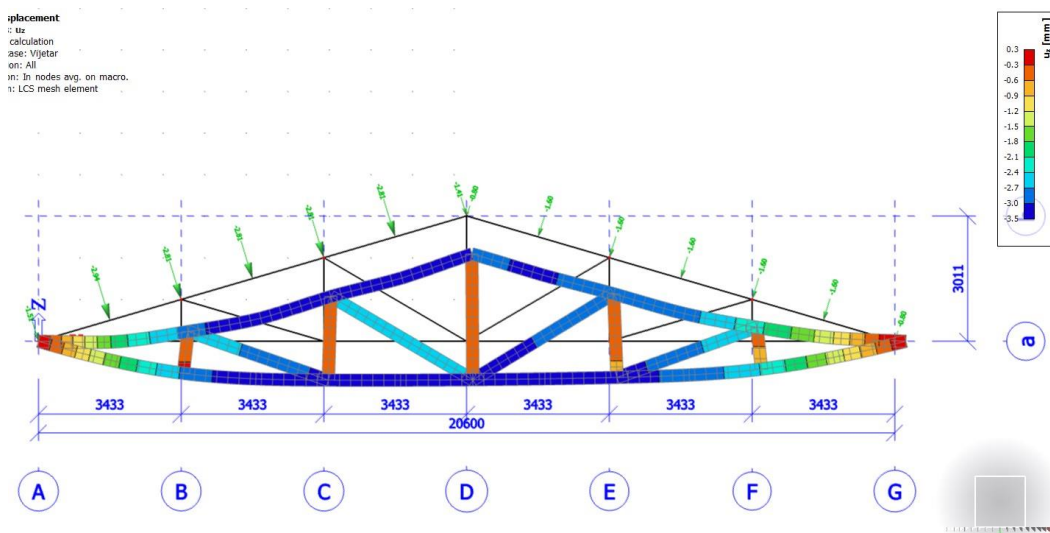

$$U_{Q,inst} = 0,35 \text{ cm}$$

$$U_{Q,fin} = u_{Q,inst}(\Psi_0 + \Psi_2 \times k_{def})$$

$$= 0,35 * (0,6 + 0 \times 0,8)$$

$$= 0,21 \text{ cm}$$

Kontrola progiba

1) a) snijeg

$$U_{Q,inst} \leq \frac{l}{300}$$

$$1,28 \text{ cm} \leq \frac{2060}{300} = 6,87 \text{ cm}$$

b) vjetar

$$U_{Q,inst} \leq \frac{l}{300}$$

$$0,35 \text{ cm} \leq \frac{2060}{300} = 6,87 \text{ cm}$$

2) $U_{fin} = u_{fin,G} + u_{fin,Q1} + u_{fin,Q2} = 1,602 + 1,28 + 0,21 = 3,092 \text{ cm}$

$$U_{fin} \leq \frac{l}{250} = \frac{2060}{250} = 8,24$$

$$3,092 \text{ cm} < 8,24 \text{ cm}$$

4. Dimenzioniranje

Karakteristične vrijednosti čvrstoća i modula elastičnosti:

$$f_{m,k} = 30 \text{ N/mm}^2$$

$$f_{t,0,k} = 19 \text{ N/mm}^2$$

$$f_{c,0,k} = 24 \text{ N/mm}^2$$

$$f_{v,k} = 4 \text{ N/mm}^2$$

$$E_{0,mean} = 12000 \text{ N/mm}^2$$

$$G_{mean} = 750 \text{ N/mm}^2$$

$$E_{0,05} = \frac{2}{3} \cdot E_{0,mean} = \frac{2}{3} \cdot 12000 = 8000 \text{ N/mm}^2$$

$$G_{0,05} = \frac{2}{3} \cdot G_{mean} = \frac{2}{3} \cdot 750 = 500 \text{ N/mm}^2$$

Proračunske vrijednosti čvrstoća:

$$f_d = k_{mod} \cdot \frac{f_k}{\gamma_M}$$

Uporabna klasa 2, dugotrajno opterećenje $k_{mod} = 0,70$

Uporabna klasa 2, kratkotrajno opterećenje $k_{mod} = 0,90$

$\gamma_M = 1,3$ - parcijalni koeficijent sigurnosti za drvo i materijale na bazi drva

$$f_{m,d} = k_{mod} \cdot \frac{f_{m,k}}{\gamma_M} = 0,90 \cdot \frac{30 \frac{\text{N}}{\text{mm}^2}}{1,3} = 20,77 \text{ N/mm}^2$$

$$f_{t,d} = k_{mod} \cdot \frac{f_{t,k}}{\gamma_M} = 0,90 \cdot \frac{19 \text{ N}}{1,3} = 13,15 \text{ N/mm}^2$$

$$f_{c,d} = k_{mod} \cdot \frac{f_{c,k}}{\gamma_M} = 0,90 \cdot \frac{24 \frac{\text{N}}{\text{mm}^2}}{1,3} = 16,62 \text{ N/mm}^2$$

$$f_{v,d} = k_{mod} \cdot \frac{f_{v,k}}{\gamma_M} = 0,90 \cdot \frac{4 \frac{\text{N}}{\text{mm}^2}}{1,3} = 2,77 \text{ N/mm}^2$$

4.1 Gornji pojas

Pretpostavljeni poprečni presjek:
 $b/h = 22/28 \text{ cm}$

Geometrijske karakteristike presjeka:

$$\begin{aligned}A &= 22 \cdot 28 = 616 \text{ cm}^2 \\I_y &= \frac{22 \cdot 28^3}{12} = 40245,33 \text{ cm}^4 \\I_z &= \frac{28 \cdot 22^3}{12} = 24845,33 \text{ cm}^4 \\W_y &= \frac{22 \cdot 28^2}{6} = 2874,67 \text{ cm}^3\end{aligned}$$

Kombinacija opterećenja 2

$$N_{c,d} = -375,37 \text{ kN}$$

$$M_{y,d} = 17 \text{ kNm}$$

$$\sigma_{c,0,d} = \frac{N_{c,d}}{A} = \frac{-375,37 \text{ kN}}{616 \text{ cm}^2} = -0,609 \frac{\text{kN}}{\text{cm}^2} = -6,09 \frac{\text{N}}{\text{mm}^2}$$

$$\sigma_{m,y,d} = \frac{M_{y,d}}{W_y} = \frac{17 \cdot 100 \text{ kNcm}}{2874,67 \text{ cm}^3} = 0,5914 \frac{\text{kN}}{\text{cm}^2} = 5,914 \frac{\text{N}}{\text{mm}^2}$$

Koeficijent izvijanja za os y:

$$l_{ef,z} = \frac{l}{\cos \alpha} = \frac{20/6}{\cos 17^\circ} = 3,590 \text{ m}$$

$$\lambda_z = \frac{l_{ef,z}}{\sqrt{\frac{I_z}{A}}} = \frac{3,590 \cdot 100 \text{ cm}}{\sqrt{\frac{24845,33 \text{ cm}^4}{616 \text{ cm}^2}}} = 56,528$$

$$\lambda_{rel,c,z} = \sqrt{\frac{f_{c,0,k}}{\sigma_{c,crit}}} = \frac{\lambda_z}{\pi} \cdot \sqrt{\frac{f_{c,0,k}}{E_{0,05}}} = \frac{56,528}{\pi} \cdot \sqrt{\frac{24,0 \frac{\text{N}}{\text{mm}^2}}{8000 \frac{\text{N}}{\text{mm}^2}}} = 0,986$$

$$\beta_c = 0,2 \text{ (puno drvo)}$$

$$\begin{aligned}k_z &= 0,5 \cdot [1 + \beta_c \cdot (\lambda_{rel,c,y} - 0,3) + \lambda_{rel,c,y}^2] = 0,5 \cdot [1 + 0,2 \cdot (0,986 - 0,3) + 0,986^2] \\&= 1,055\end{aligned}$$

$$k_{c,z} = \min \left\{ \frac{1}{k_z + \sqrt{k_z^2 - \lambda_{rel,c,z}^2}}; 1,0 \right\} = \min \left\{ \frac{1}{1,055 + \sqrt{1,055^2 - 0,986^2}}; 1,0 \right\}$$

$$= \min\{0,699; 1,0\} = 0,699$$

Za savijane štapove pravokutnog poprečnog presjeka širine b , $k_m = 1,0$, ako je:

$$\frac{(l_{eff} \cdot h)}{b^2} = \frac{359\text{cm} \cdot 28\text{cm}}{22^2 \text{cm}^2} = 20,77 < 140 \Rightarrow k_{crit} = 1,0$$

Dokaz stabilnosti za os y :

$$\frac{\sigma_{m,y,d}}{k_{crit} \cdot f_{m,y,d}} + \frac{\sigma_{c,0,d}}{k_{c,z} \cdot f_{c,0,d}} < 1$$

$$\frac{5,914}{1,0 \cdot 20,77} + \frac{6,09}{0,699 \cdot 16,62} = 0,81 < 1$$

Posmik:

$$\tau_d = 1,5 \cdot \frac{V_d}{A} = 1,5 \cdot \frac{12,11 \text{ kN}}{616 \text{ cm}^2} = 0,0295 \frac{\text{kN}}{\text{cm}^2} = 0,295 \frac{\text{N}}{\text{mm}^2}$$

$$\frac{\tau_d}{f_{v,d}} = \frac{0,295 \text{ N/mm}^2}{2,77 \text{ N/mm}^2} = 0,106 < 1$$

Poprečni presjek zadovoljava. Usvojeno $b/h = 22/28 \text{ cm}$

4.2 Donji pojas

Pretpostavljeni poprečni presjek:
 $b/h = 22/26 \text{ cm}$

Geometrijske karakteristike presjeka:

$$\begin{aligned}A &= 22 \cdot 26 = 572 \text{ cm}^2 \\I_y &= \frac{22 \cdot 26^3}{12} = 32222,67 \text{ cm}^4 \\I_z &= \frac{26 \cdot 22^3}{12} = 23070,67 \text{ cm}^4 \\W_y &= \frac{22 \cdot 26^2}{6} = 2478,67 \text{ cm}^3\end{aligned}$$

Kombinacija opterećenja 2

$$N_{t,d} = 359,26 \text{ kN}$$

$$M_{y,d} = 11,26 \text{ kNm}$$

$$\sigma_{t,0,d} = \frac{N_{t,d}}{A_{netto}} = \frac{359,26 \text{ kN}}{0,80 \cdot 572 \text{ cm}^2} = 0,785 \frac{\text{kN}}{\text{cm}^2} = 7,85 \frac{\text{N}}{\text{mm}^2}$$

$$\sigma_{m,y,d} = \frac{M_{y,d}}{W_y} = \frac{11,26 \cdot 100 \text{ kNcm}}{2478,67 \text{ cm}^3} = 0,454 \frac{\text{kN}}{\text{cm}^2} = 4,54 \frac{\text{N}}{\text{mm}^2}$$

$$\frac{(l_{eff} \cdot h)}{b^2} = \frac{2060 \text{ cm} \cdot 26 \text{ cm}}{22^2 \text{ cm}^2} = 110,66 < 140 \Rightarrow k_{crit} = 1,0$$

$$\frac{\sigma_{m,y,d}}{k_{crit} \cdot f_{m,y,d}} + \frac{\sigma_{t,0,d}}{f_{t,0,d}} < 1$$

$$\frac{4,54}{1 \cdot 20,77} + \frac{7,85}{16,62} = 0,82 < 1$$

Posmik:

$$\tau_d = 1,5 \cdot \frac{V_d}{A} = 1,5 \cdot \frac{8,82 \text{ kN}}{572 \text{ cm}^2} = 0,0231 \frac{\text{kN}}{\text{cm}^2} = 0,231 \frac{\text{N}}{\text{mm}^2}$$

$$\frac{\tau_d}{f_{v,d}} = \frac{0,231 \text{ N/mm}^2}{2,77 \text{ N/mm}^2} = 0,083 < 1$$

Poprečni presjek zadovoljava. Usvojeno $b/h = 22/26 \text{ cm}$

4.3 Dijagonale

Pretpostavljeni poprečni presjek:
 $b/h = 22/12 \text{ cm}$

Geometrijske karakteristike presjeka:

$$\begin{aligned}A &= 22 \cdot 12 = 264 \text{ cm}^2 \\I_y &= \frac{22 \cdot 12^3}{12} = 3168 \text{ cm}^4 \\I_z &= \frac{12 \cdot 22^3}{12} = 10648 \text{ cm}^4\end{aligned}$$

Kombinacija opterećenja 2

$$N_{c,d} = -90,19 \text{ kN}$$

$$\sigma_{c,0,d} = \frac{N_{c,d}}{A} = \frac{-90,19 \text{ kN}}{264 \text{ cm}^2} = -0,342 \frac{\text{kN}}{\text{cm}^2} = -3,42 \frac{\text{N}}{\text{mm}^2}$$

Koeficijent izvijanja za os y:

$$l_{ef,y} = 3,9766 \text{ m}$$

$$\lambda_y = \frac{l_{ef,y}}{\sqrt{\frac{I_y}{A}}} = \frac{3,9766 \cdot 100 \text{ cm}}{\sqrt{\frac{3168 \text{ cm}^4}{264 \text{ cm}^2}}} = 114,79$$

$$\lambda_{rel,c,y} = \sqrt{\frac{f_{c,0,k}}{\sigma_{c,crit}}} = \frac{\lambda_y}{\pi} \cdot \sqrt{\frac{f_{c,0,k}}{E_{0,05}}} = \frac{114,79}{\pi} \cdot \sqrt{\frac{24,0 \frac{\text{N}}{\text{mm}^2}}{8000,00 \frac{\text{N}}{\text{mm}^2}}} = 2,001$$

$$\beta_c = 0,2 \text{ (puno drvo)}$$

$$k_y = 0,5 \cdot [1 + \beta_c \cdot (\lambda_{rel,c,y} - 0,3) + \lambda_{rel,c,y}^2] = 0,5 \cdot [1 + 0,2 \cdot (2,001 - 0,3) + 2,001^2] = 2,69$$

$$k_{c,y} = \min \left\{ \frac{1}{k_y + \sqrt{k_y^2 - \lambda_{rel,c,y}^2}}; 1,0 \right\} = \min \left\{ \frac{1}{2,69 + \sqrt{2,69^2 - 2,001^2}}; 1,0 \right\}$$

$$= \min\{0,223; 1,0\} = 0,223$$

Za savijane štapove pravokutnog poprečnog presjeka širine b , $k_m = 1,0$, ako je:

$$\frac{(l_{eff} \cdot h)}{b^2} = \frac{397,66 \text{ cm} \cdot 12 \text{ cm}}{22^2 \text{ cm}^2} = 9,86 < 140 \Rightarrow k_m = 1,0$$

Dokaz stabilnosti za os y :

$$\frac{\sigma_{c,0,d}}{k_{c,y} \cdot f_{c,0,d}} < 1$$

$$\frac{3,42}{0,223 \cdot 16,62} = 0,923 < 1$$

Poprečni presjek zadovoljava. Usvojeno $b/h = 22/12 \text{ cm}$

4.4 Vertikale

Pretpostavljeni poprečni presjek:
 $b/h = 22/12\text{cm}$

Geometrijske karakteristike presjeka:

$$\begin{aligned}A &= 22 \cdot 12 = 264 \text{ cm}^2 \\I_y &= \frac{22 \cdot 12^3}{12} = 3168 \text{ cm}^4 \\I_z &= \frac{12 \cdot 22^3}{12} = 10648 \text{ cm}^4\end{aligned}$$

Kombinacija opterećenja 2

$$N_{t,d} = 91,05 \text{ kN}$$

$$\sigma_{t,0,d} = \frac{N_{t,d}}{A_{netto}} = \frac{91,05 \text{ kN}}{0,80 \cdot 264 \text{ cm}^2} = 0,431 \frac{\text{kN}}{\text{cm}^2} = 4,31 \frac{\text{N}}{\text{mm}^2}$$

$$\frac{\sigma_{t,0,d}}{f_{t,0,d}} < 1$$

$$\frac{4,31}{13,15} = 0,33 < 1$$

Poprečni presjek zadovoljava. Usvojeno $b/h = 22/12 \text{ cm}$

4.5 Podrožnice

Najveće opterećenje za stabilizaciju uzrokuje kombinacija koja uključuje vlastitu težinu, snijeg i vjetar.

Van sustava stabilizacije $b/h = 18/20$ cm

Djelovanja

$$\begin{aligned} q_{G,k} &= g_k \cdot e = 0,5 \text{ kN/m}^2 \cdot 1,795 \text{ m} = 0,898 \text{ kN/m} \\ q_{Q,k,W} &= w_z \cdot e = 0,374 \text{ kN/m}^2 \cdot 1,795 \text{ m} = 0,671 \text{ kN/m} \\ q_{Q,k,S} &= s \cdot e = 1,0 \text{ kN/m}^2 \cdot 1,795 \text{ m} = 1,795 \text{ kN/m} \\ q_{z,d} &= 1,35 \cdot q_{G,k} \cdot \cos \alpha + 1,50 \cdot 0,9 \cdot (q_{Q,k,W} + q_{Q,k,S} \cdot \cos \alpha) = 4,383 \text{ kN/m} \\ q_{y,d} &= 1,35 \cdot q_{G,k} \cdot \sin \alpha + 1,50 \cdot 0,9 \cdot q_{Q,k,S} \cdot \sin \alpha = 1,063 \text{ kN/m} \end{aligned}$$

Rezne sile:

$$\begin{aligned} M_{y,d} &= \frac{q_{z,d} \cdot l^2}{8} = \frac{4,383 \cdot 4,5^2}{8} = 11,09 \text{ kNm} \\ M_{z,d} &= \frac{q_{y,d} \cdot l^2}{8} = \frac{1,063 \cdot 4,5^2}{8} = 2,69 \text{ kNm} \\ V_{y,d} &= \frac{q_{z,d} \cdot l}{2} = \frac{4,383 \cdot 4,5}{2} = 9,86 \text{ kN} \\ V_{z,d} &= \frac{q_{y,d} \cdot l}{2} = \frac{1,063 \cdot 4,5}{2} = 2,39 \text{ kN} \end{aligned}$$

Karakteristike poprečnog presjeka:

$$\begin{aligned} A &= 18 \cdot 20 = 360 \text{ cm}^2 \\ W_y &= \frac{18 \cdot 20^2}{6} = 1200 \text{ cm}^3 \\ W_z &= \frac{20 \cdot 18^2}{6} = 1080 \text{ cm}^3 \end{aligned}$$

Proračunska naprezanja:

$$\begin{aligned} \sigma_{m,y,d} &= \frac{M_{y,d}}{W_y} = \frac{11,09 \cdot 10^6}{1200 \cdot 10^3} = 9,24 \text{ N/mm}^2 \\ \sigma_{m,z,d} &= \frac{M_{z,d}}{W_z} = \frac{2,69 \cdot 10^6}{1080 \cdot 10^3} = 2,49 \text{ N/mm}^2 \\ \tau_{y,d} &= 1,5 \cdot \frac{V_{y,d}}{A} = 1,5 \cdot \frac{9,86 \cdot 10^3}{360 \cdot 10^2} = 0,41 \text{ N/mm}^2 \\ \tau_{z,d} &= 1,5 \cdot \frac{V_{z,d}}{A} = 1,5 \cdot \frac{2,39 \cdot 10^3}{360 \cdot 10^2} = 0,0996 \text{ N/mm}^2 \\ \frac{l_{ef} \cdot h}{b^2} &= \frac{450 \cdot 20}{18^2} = 27,78 < 140 \rightarrow k_m = 1,0 \end{aligned}$$

Dokaz nosivosti i stabilnosti:

$$\begin{aligned} \frac{\sigma_{m,y,d}}{k_m \cdot f_{m,d}} + k_{red} \cdot \frac{\sigma_{m,z,d}}{f_{m,d}} &= \frac{9,24}{1,0 \cdot 20,77} + 0,7 \cdot \frac{2,49}{20,77} = 0,529 < 1,0 \\ k_{red} \cdot \frac{\sigma_{m,y,d}}{k_m \cdot f_{m,d}} + \frac{\sigma_{m,z,d}}{f_{m,d}} &= 0,7 \cdot \frac{9,24}{1,0 \cdot 20,77} + \frac{2,49}{20,77} = 0,431 < 1,0 \\ \left(\frac{\tau_{y,d}}{f_{v,d}} \right)^2 + \left(\frac{\tau_{z,d}}{f_{v,d}} \right)^2 &= \left(\frac{0,41}{2,77} \right)^2 + \left(\frac{0,0996}{2,77} \right)^2 = 0,023 < 1,0 \end{aligned}$$

Poprečni presjek zadovoljava. Usvojeno $b/h = 18/20$ cm

5. Stabilizacija

Proračunska vrijednost komponente poprečnog djelovanja stabilizacijskog veza izazvana bočnim izvijanjem glavnog nosača napreznog savijanjem

$$q_d = k_l \frac{n \cdot N_d}{30 \cdot l} = 0,853 \cdot \frac{5,5 \cdot 1,093}{30 \cdot 21,54} = 0,00794 \approx 0$$

$$k_l = \min \left\{ \sqrt{\frac{15}{l}} = \sqrt{\frac{15}{20,6}} = 0,853 \right.$$

$$\left. n = \frac{11}{2} = 5,5 \right.$$

Koeficijent izbočavanja:

$$k_{crit} = \begin{cases} 1 & \text{za } \lambda_{rel,m} \leq 0,75 \\ 1,56 - 0,75 \cdot \lambda_{rel,m} & \text{za } 0,75 < \lambda_{rel,m} \leq 1,4 \\ \frac{1}{\lambda_{rel,m}^2} & \text{za } 1,4 < \lambda_{rel,m} \end{cases}$$

$$\lambda_{rel,m} = \sqrt{\frac{l_{ef} \cdot h_1}{\pi \cdot b_1^2}} \cdot \sqrt{\frac{f_{m,k}}{\sqrt{E_{0,05} \cdot G_{05}}}}$$

$$l_{ef} = 21,54 \text{ m}$$

$$\lambda_{rel,m} = \sqrt{\frac{21,54 \cdot 10^3 \cdot 280}{\pi \cdot 220^2}} \cdot \sqrt{\frac{30}{\sqrt{8000 \cdot 500}}} = 0,771 \geq 0,75$$

$$k_{crit} = 1,56 - 0,75 \cdot \lambda_{rel,m} = 1,56 - 0,75 \cdot 0,771 = 0,982$$

$$N_d = (1 - k_{crit}) \cdot \frac{M_y}{h} = (1 - 0,982) \cdot \frac{17}{0,28} = 1,093$$

Djelovanje vjetra (na jedan spreg)

$$Q_B = N_{d,mean} \frac{1 - kc}{80} = 296,4 \text{ kN} \cdot \frac{1 - 0,141}{80} = 3,183 \text{ kN}$$

ZONA A

$$q_{w,1,d} = \frac{q_{w,d}}{2} = \frac{(1,2 + 0,2) \cdot 0,66}{2} \cdot \frac{10}{2} = 2,31 \text{ kN/m}^2$$

$$q_{TOT,d} = q_{w,1,d} + q_d = 1,44 + 0 = 2,31 \text{ kN/m}^2$$

$$Q_{w1} = q_{TOT,d} \cdot \bar{a} = 2,31 \cdot 3,59 = 8,29 \text{ kN}$$

$$Q_{d1} = Q_{w1} + Q_B = 8,29 + 3,183 = 11,473 \text{ kN}$$

ZONA B

$$q_{w,1,d} = \frac{q_{w,d}}{2} = \frac{(0,8 + 0,2) \cdot 0,66}{2} \cdot \frac{10}{2} = 1,65 \text{ kN/m}^2$$

$$q_{TOT,d} = q_{w,1,d} + q_d = 1,44 + 0 = 1,65 \text{ kN/m}^2$$

$$Q_{w2} = q_{TOT,d} \cdot \bar{a} = 1,65 \cdot 3,59 = 5,92 \text{ kN}$$

$$Q_{d2} = Q_{w1} + Q_B = 5,92 + 3,183 = 9,103 \text{ kN}$$

ZONA C

$$q_{w,1,d} = \frac{q_{w,d}}{2} = \frac{(0,5 + 0,2) \cdot 0,66}{2} \cdot \frac{10}{2} = 1,16 \text{ kN/m}^2$$

$$q_{TOT,d} = q_{w,1,d} + q_d = 1,16 + 0 = 1,16 \text{ kN/m}^2$$

$$Q_{w3} = q_{TOT,d} \cdot \bar{a} = 1,16 \cdot 3,59 = 4,16 \text{ kN}$$

$$Q_{d3} = Q_{w1} + Q_B = 4,16 + 3,183 = 7,343 \text{ kN}$$

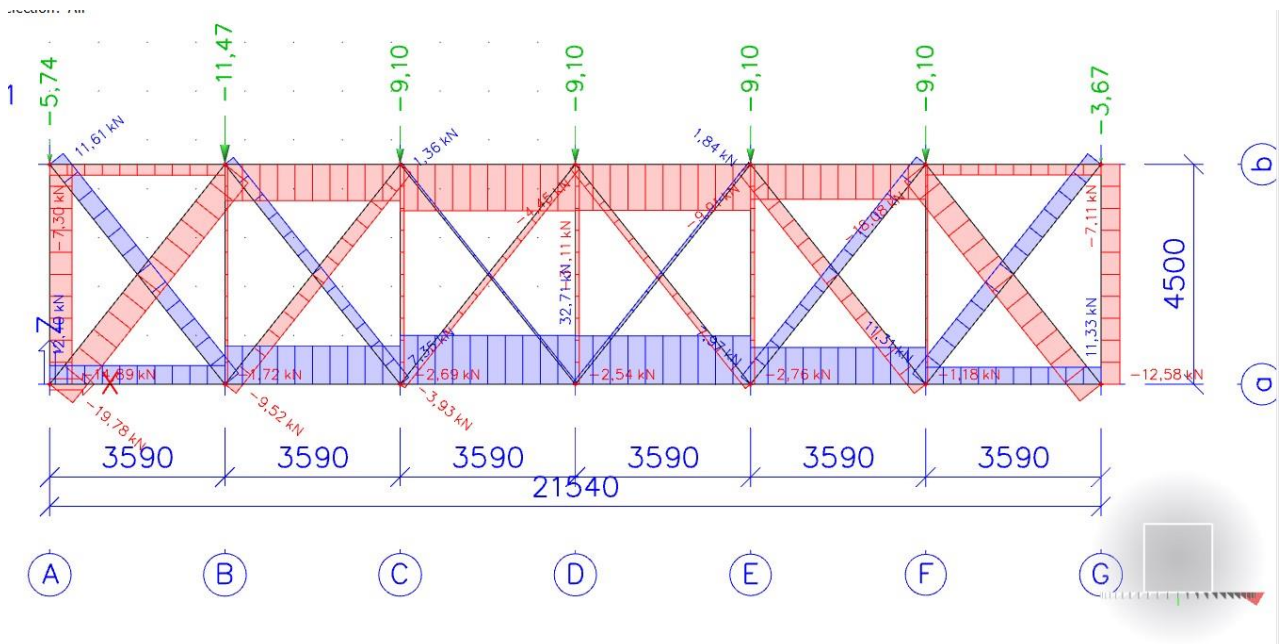

5.1 Dokaz za gornji pojas glavnog nosača (pojasevi sprega)

Ispuna sprega spojena je na glavne nosače u ravnini ili neposredno ispod gornjeg pojasa nosača. Pretpostavlja se približno jednolika raspodjela naprezanja od uvođenja sile ispune sprega u glavni nosač na 1/6 njegove visine (sudjelujuća visina).

$$\bar{h}_1 = \frac{h_1}{6} = \frac{28}{6} = 4,667 \text{ cm}$$

$$\bar{A} = b_1 \cdot \bar{h}_1 = 22 \cdot 4,667 = 102,67 \text{ cm}^2$$

Proračunsko naprezanje od $N_{O_3(U_3)d} = 31,11 \text{ kN}$

$$\sigma_{c,0,d, \text{stabilizacija}} = \frac{N_{O_3(U_3)d}}{\bar{A}} = \frac{31,11 \cdot 10^3}{102,67 \cdot 10^2} = 3,03 \text{ N/mm}^2$$

Koeficijent izvijanja za os y:

$$l_{ef,z} = \frac{l}{\cos \alpha} = \frac{20,6/6}{\cos 17^\circ} = 3,59 \text{ m}$$

$$\lambda_y = \frac{l_{ef,y}}{\sqrt{\frac{I_y}{A}}} = \frac{3,59 \cdot 100 \text{ cm}}{\sqrt{\frac{40245,33 \text{ cm}^4}{616 \text{ cm}^2}}} = 44,41$$

$$\lambda_{rel,c,y} = \sqrt{\frac{f_{c,0,k}}{\sigma_{c,crit}}} = \frac{\lambda_y}{\pi} \cdot \sqrt{\frac{f_{c,0,k}}{E_{0,05}}} = \frac{44,41}{\pi} \cdot \sqrt{\frac{24,0 \frac{\text{N}}{\text{mm}^2}}{8000,00 \frac{\text{N}}{\text{mm}^2}}} = 0,774$$

$$\beta_c = 0,2 \text{ (puno drvo)}$$

$$k_y = 0,5 \cdot [1 + \beta_c \cdot (\lambda_{rel,c,y} - 0,3) + \lambda_{rel,c,y}^2] = 0,5 \cdot [1 + 0,2 \cdot (0,774 - 0,3) + 0,774^2] = 0,85$$

$$k_{c,y} = \min \left\{ \frac{1}{k_y + \sqrt{k_y^2 - \lambda_{rel,c,y}^2}}; 1,0 \right\} = \min \left\{ \frac{1}{0,85 + \sqrt{0,85^2 - 0,774^2}}; 1,0 \right\} \\ = \min\{0,832; 1,0\} = 0,832$$

Dokaz nosivosti i stabilnosti

$$\frac{\sigma_{c,0,d, \text{stabilizacija}}}{k_{c,y} \cdot f_{c,0,d}} + \frac{\sigma_{m,y,d}}{k_m \cdot f_{m,y,d}} + \frac{\sigma_{c,0,d}}{k_{c,z} \cdot f_{c,0,d}} < 1 \\ \frac{3,03}{0,832 \cdot 16,62} + \frac{5,914}{1,0 \cdot 20,77} + \frac{6,09}{0,699 \cdot 16,62} = 0,998 < 1$$

5.2 Dokaz za podrožnice (vertikale sprega)

$$\sigma_{c,0,V_1,d, stabilizacija} = \frac{N_{V_1,d}}{A} = \frac{14,89 \cdot 10^3}{360 \cdot 10^2} = 0,414 \text{ N/mm}^2$$

Koeficijent izvijanja za os y:

$$l_{ef,z} = 4,5 \text{ m}$$

$$\lambda_z = \frac{l_{ef,z}}{\sqrt{\frac{I_y}{A}}} = \frac{4,5 \cdot 100 \text{ cm}}{\sqrt{\frac{6804 \text{ cm}^4}{360 \text{ cm}^2}}} = 103,51$$

$$\lambda_{rel,c,y} = \sqrt{\frac{f_{c,0,k}}{\sigma_{c,crit}}} = \frac{\lambda_y}{\pi} \cdot \sqrt{\frac{f_{c,0,k}}{E_{0,05}}} = \frac{103,51}{\pi} \cdot \sqrt{\frac{24,0 \frac{\text{N}}{\text{mm}^2}}{8000,00 \frac{\text{N}}{\text{mm}^2}}} = 1,805$$

$$\beta_c = 0,2 \text{ (puno drvo)}$$

$$k_y = 0,5 \cdot [1 + \beta_c \cdot (\lambda_{rel,c,y} - 0,3) + \lambda_{rel,c,y}^2] = 0,5 \cdot [1 + 0,2 \cdot (1,805 - 0,3) + 1,805^2] = 2,28$$

$$k_{c,y} = \min \left\{ \frac{1}{k_y + \sqrt{k_y^2 - \lambda_{rel,c,y}^2}}; 1,0 \right\} = \min \left\{ \frac{1}{2,28 + \sqrt{2,28^2 - 1,805^2}}; 1,0 \right\} \\ = \min\{0,272; 1,0\} = 0,272$$

Komentar: Proračun je na strani sigurnosti jer je kod $\sigma_{c,0,V_1,d}$ uzeta sila u prvoj podrožnici – vertikali sprega.

Dokaz nosivosti i stabilnosti

$$\frac{\sigma_{c,0,V_1,d, stabilizacija}}{k_{c,y} \cdot f_{c,0,d}} + \frac{\sigma_{m,y,d}}{k_m \cdot f_{m,d}} + k_{red} \cdot \frac{\sigma_{m,z,d}}{f_{m,d}} < 1,0 \\ \frac{0,564}{0,272 \cdot 16,62} + \frac{9,24}{1,0 \cdot 20,77} + 0,7 \cdot \frac{2,49}{20,77} = 0,654 < 1,0$$

$$\frac{\sigma_{c,0,V_1,d, stabilizacija}}{k_{c,y} \cdot f_{c,0,d}} + k_{red} \cdot \frac{\sigma_{m,y,d}}{k_m \cdot f_{m,d}} + \frac{\sigma_{m,z,d}}{f_{m,d}} < 1,0 \\ \frac{0,564}{0,272 \cdot 16,62} + 0,7 \cdot \frac{9,24}{1,0 \cdot 20,77} + \frac{2,49}{20,77} = 0,556 < 1,0$$

5.3 Dokaz za dijagonale

$$\emptyset 10 (M10) \quad A_{netto} = 0,785 \text{ cm}^2$$

$$\sigma_{D_1d} = \frac{N_{D_1d}}{A_{netto}} = \frac{11,61 \cdot 10^3}{0,785 \cdot 10^2} = 147,898 \text{ N/mm}^2$$

S235

$$\sigma_{R,d} = \frac{f_{y,k}}{\gamma_M} = \frac{235}{1,0} = 235,0 \text{ N/mm}^2$$

$$\frac{\sigma_{D_1d}}{\sigma_{R,d}} = \frac{147,898}{235} = 0,63 < 1,0$$

6. Proračun spajala

6.1 Proračun vlačnog nastavka donjeg pojasa

Osnovni materijal: puno drvo, 22/26 cm

klasa čvrstoće C30

Djelovanja: $N_d=293,7$ kN

Uporabna klasa 2

Tijesno ugrađeni vijci Φ 16mm (M16) kl. čvrstoće 5.6

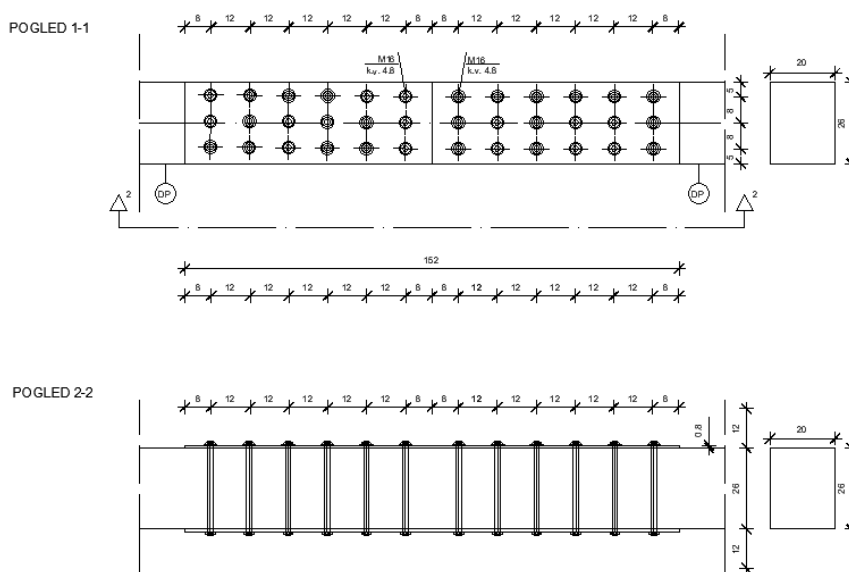

$$f_{u,k} = 400 \text{ N/mm}^2$$

$$k_{mod} = 0,90$$

$$\gamma_M = 1,3 \text{ (drvo)}$$

$$\gamma_M = 1,1 \text{ (vijci*)}$$

$$C30 \rightarrow \rho_{k,1} = 380 \text{ kg/m}^3$$

$$f_{h,2,k} = 0,082 \cdot (1 - 0,01 \cdot d) \cdot \rho_k = 0,082 \cdot (1 - 0,01 \cdot 16) \cdot 380 = 26,17 \text{ N/mm}^2$$

$$M_{y,k} = 0,3 \cdot f_{u,k} \cdot d^{2,6} = 0,3 \cdot 400 \cdot 16^{2,6} = 162,14 \text{ Nm}$$

Nosivost na posmik:

$$F_{v,Rk} = \min \left\{ \begin{array}{l} 0,5 \cdot f_{h,2,k} \cdot t_2 \cdot d = 0,5 \cdot 26,17 \cdot 0,22 \cdot 0,016 = 42,43 \text{ kN} \\ 1,15 \cdot \sqrt{2 \cdot M_{y,Rk} \cdot f_{h,2,k} \cdot d} = 1,15 \cdot \sqrt{2 \cdot 162,14 \cdot 26,17 \cdot 10^6 \cdot 0,016} = 13,4 \text{ kN/vijku} \end{array} \right.$$

$$F_{v,Rk} = 13,4 \text{ kN/vijku}$$

Nosivost na izvlačenje:

$$\text{Fiktivni promjer podloška } D = \min \left\{ \begin{array}{l} 12 \cdot t = 12 \cdot 8 = 96 \text{ mm} \\ 4 \cdot d = 4 \cdot 16 = 64 \text{ mm} \end{array} \right.$$

$$A_{\text{podloška}} = \frac{(64^2 - 16^2)\pi}{4} = 3015,93 \text{ mm}^2$$

$$F_{ax,\text{podloška},Rk} = 3 \cdot f_{c,90,k} \cdot A_{\text{podloška}} = 3 \cdot 2,7 \cdot 3015,93 = 24,429 \text{ kN}$$

Nosivost jednog vijka:

$$F_{Rk} = F_{v,Rk} + 2 \cdot \frac{F_{ax,\text{podloška},Rk}}{4} = 13,4 + 2 \cdot \frac{24,429}{4} = 25,61 \text{ kN}$$

Proračunska vrijednost nosivosti vijaka/rezu:

$$R_{Rd} = k_{mod} \cdot \frac{R_{Rk}}{\gamma_M} ; \gamma_M = 1,1$$

$$R_{Rd} = 0,9 \cdot \frac{25,61}{1,1} = 17,73 \text{ kN}$$

Potreban broj redova vijaka:

$$n_{redova} = \frac{293,7}{16,57} = 16,57 \rightarrow 18 \text{ vijaka}$$

$$n_{redova} = \left(\frac{h-2 \cdot 3d}{4d} \right) + 1 = \left(\frac{260-2 \cdot 3 \cdot 16}{4 \cdot 16} \right) + 1 = 3,56 \quad \text{ODABRANO : 3 reda}$$

Grupni učinak vijaka:

$$3 \cdot n_{ef} \cdot F_{Rd} = F_d$$

$$n^{0,9} \cdot \sqrt[4]{\frac{7d}{13d}} = \frac{F_d}{3 \cdot F_{Rd}}$$

$$n = \min \left\{ \frac{F_d}{3 \cdot F_{Rd}}; \quad n^{0,9} \cdot \sqrt[4]{\frac{7d}{13d}} \right\} = \min \left\{ \frac{300}{3 \cdot 17,73}; \quad n^{0,9} \cdot \sqrt[4]{\frac{7d}{13d}} \right\}$$

$$n = \min \left\{ 5,64 \approx 6; \quad 6^{0,9} \cdot \sqrt[4]{\frac{7 \cdot 16}{13 \cdot 16}} \right\} = \min \left\{ \frac{300}{3 \cdot 17,73}; \quad 14,72 \right\}$$

$$n = 6 \text{ vijaka/redu}$$

Konstruktivni zahtjevi – minimalni razmaci:

Paralelno sa vlakancima:

$$a_{1,req} = (3 + 2 \cdot \cos \alpha) \cdot d$$
$$a_{1,req} = (3 + 2 \cdot \cos 0) \cdot 16 = 80 \text{ mm} \leq 80 \text{ mm}$$

Okomito na vlakanca:

$$a_{2,req} = 3 \cdot d$$
$$a_{2,req} = 3 \cdot 16 = 48 \text{ mm} < 60 \text{ mm}$$

Od opterećenog kraja (paralelno s vlakancima):

$$a_{1,t} = \min(7d; 80 \text{ mm}) = \min(7 \cdot 16; 80) = \min(112; 80) = 80 \text{ mm} < 120 \text{ mm}$$

Od neopterećenog ruba (okomito na vlakanca):

$$a_{2,c} = 3 \cdot d = 3 \cdot 16 = 48 \text{ mm} < 50 \text{ mm}$$

6.2 Detalj 2- dvostruki zasjek

GP b/h = 22/28 cm

DP b/h = 22/26 cm

Nd = -359.35 kN

$$t_{v,max} = \frac{h}{4} = \frac{26}{4} = 6.5 \text{ cm}$$

tv,1 = 6 cm < 7.5 cm

tv,2 = 5.5 cm < 7.5 cm

$\gamma = 17^\circ$, $\alpha = 8.5^\circ$

Osiguranje M 12 – KONSTRUKTIVNO

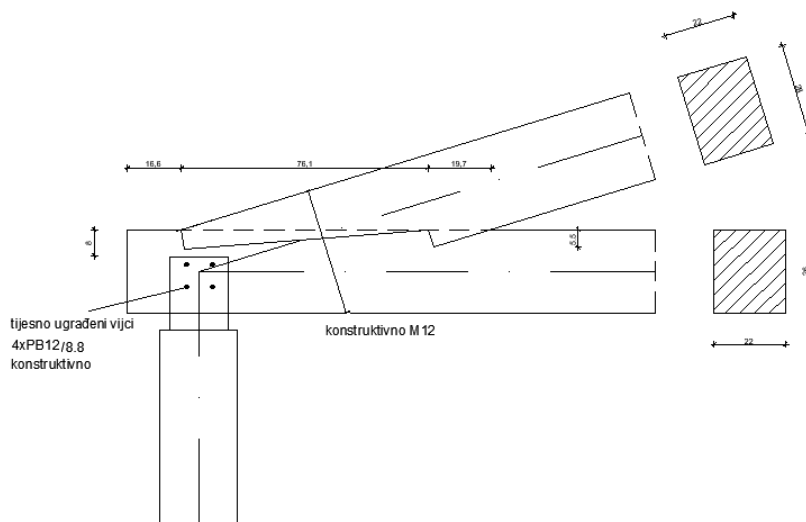

PREDNJI ZASJEK

$$R_{1,d} = f_{c, \alpha, d} \cdot A_1$$

$$f_{c, \alpha, d} = \frac{f_{c, o, d}}{\sqrt{\left(\frac{f_{c, o, d}}{2 \cdot f_{c, 90, d}} \cdot \sin^2 \alpha\right)^2 + \left(\frac{f_{c, o, d}}{2 \cdot f_{v, d}} \cdot \cos \alpha \cdot \sin \alpha\right)^2 + \cos^4 \alpha}}$$

$$f_{c, \alpha, d} = \frac{16,62}{\sqrt{\left(\frac{16,62}{2 \cdot 1,87} \cdot \sin^2 8,5\right)^2 + \left(\frac{16,62}{2 \cdot 2,77} \cdot \cos 8,5 \cdot \sin 8,5\right)^2 + \cos^4 8,5}}$$

$$f_{c, \alpha, d} = 15,44 \text{ N/mm}^2$$

$$A_1 = \frac{b_1 \cdot t_{v,1}}{\cos \alpha} = \frac{22 \cdot 6}{\cos 8,5} = 133,47 \text{ cm}^2$$

$$R_{1,d} = 15,44 \cdot 10^{-1} \cdot 133,47 = 206,08 \text{ kN}$$

$$R_{1,d,stv} = \frac{R_{1,d}}{\cos 8,5} = \frac{206,08}{\cos 8,5} = 208,37 \text{ kN}$$

STRAŽNJI ZASJEK

$$R_{2,d} = f_{c, \alpha, d} \cdot A_2$$

$$f_{c, \alpha, d} = \frac{f_{c, o, d}}{\sqrt{\left(\frac{f_{c, o, d}}{2 \cdot f_{c, 90, d}} \cdot \sin^2 \alpha\right)^2 + \left(\frac{f_{c, o, d}}{2 \cdot f_{v, d}} \cdot \cos \alpha \cdot \sin \alpha\right)^2 + \cos^4 \alpha}}$$

$$f_{c, \alpha, d} = \frac{16,62}{\sqrt{\left(\frac{16,62}{2 \cdot 1,87} \cdot \sin^2 17\right)^2 + \left(\frac{16,62}{2 \cdot 2,77} \cdot \cos 17 \cdot \sin 17\right)^2 + \cos^4 17}}$$

$$f_{c, \alpha, d} = 12,81 \text{ N/mm}^2$$

$$A_2 = \frac{b_2 \cdot t_{v,2}}{\cos \alpha} = \frac{22 \cdot 5,5}{\cos 17} = 126,53 \text{ cm}^2$$

$$R_{2,d} = 12,81 \cdot 10^{-1} \cdot 126,53 = 162,08 \text{ kN}$$

$$R_{2,d,stv} = R_{2,d}$$

$$R_{tot,d} = R_{1,d,stv} + R_{2,d,stv} = 208,37 + 162,08 = 370,45$$

$$\text{Dokaz: } \frac{359,35}{370,45} = 0,97 < 1 \quad (97\%)$$

6.3 Detalj 3- jednostruki zasjek i bušeni čavli

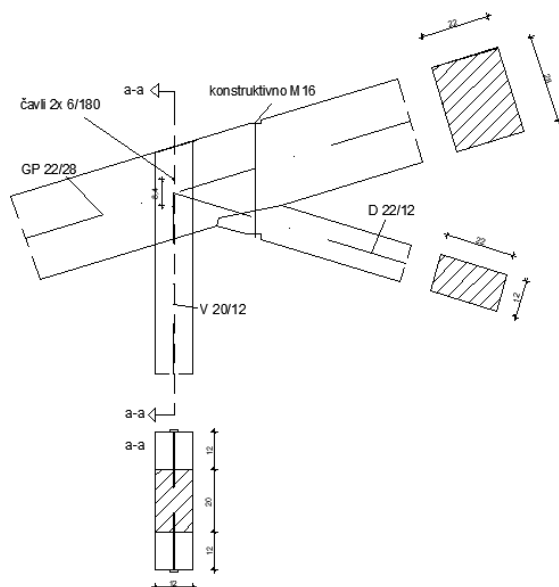

GP 22/28 cm

dijagonala 22/12

vertikala 2x12/12

$$t_{v,max} = \frac{h}{6} = \frac{28}{6} = 4,7 \text{ cm}$$

$$t_v = 2,5 \text{ cm} < 4,7 \text{ cm}$$

Osiguranje M12- konstruktivno

$$f_{c, \alpha, d} = \frac{f_{c, 0, d}}{\sqrt{\left(\frac{f_{c, 0, d}}{2 \cdot f_{c, 90, d}} \cdot \sin^2 \alpha\right)^2 + \left(\frac{f_{c, 0, d}}{2 \cdot f_{v, d}} \cdot \cos \alpha \cdot \sin \alpha\right)^2 + \cos^4 \alpha}}$$

$$f_{c, \alpha, d} = \frac{16,62}{\sqrt{\left(\frac{16,62}{2 \cdot 1,87} \cdot \sin^2 17\right)^2 + \left(\frac{16,62}{2 \cdot 2,77} \cdot \cos 17 \cdot \sin 17\right)^2 + \cos^4 17}}$$

$$f_{c, \alpha, d} = 12,81 \text{ N/mm}^2$$

$$A_1 = \frac{b_1 \cdot t_{v,1}}{\cos \alpha} = \frac{22 \cdot 2,5}{\cos 17} = 57,51 \text{ cm}^2$$

$$\sigma_{1, d} = \frac{N_{c, d} \cdot \cos \alpha}{A_1} = \frac{61,56 \cdot \cos 17}{57,51} \cdot 10 = 10,24 \text{ N/mm}$$

$$\text{Dokaz: } \frac{\sigma_{1, d}}{f_{c, \alpha, d}} = \frac{10,24}{12,81} = 0,8 < 1 \quad (80\%)$$

Bušeni čavli 6/180

$$f_{u, k} = 600 \text{ N/mm}^2$$

$$F_d = 3,52 \text{ kN}, \quad \alpha = 73^\circ$$

$$f_{h,0,k} = 0,082 \cdot (1 - 0,01 \cdot d) \cdot \rho_k = 0,082 \cdot (1 - 0,01 \cdot 6) \cdot 380 = 29,29 \text{ N/mm}^2$$

$$M_{y,k} = 0,3 \cdot f_{u,k} \cdot d^{2,6} = 0,3 \cdot 600 \cdot 6^{2,6} = 18987,41 \text{ Nmm}$$

$$R_k = \sqrt{2 \cdot M_{y,k} \cdot f_{h,\alpha,k} \cdot d} = R_k = \sqrt{2 \cdot 18987,41 \cdot 29,29 \cdot 6} = 2583,35 \text{ N}$$

Kontrola debljine- bočna drva

$$t_{REQ} = 9 \cdot d = 54 \text{ mm}$$

$$t_{REQ} = 54 \text{ mm} < t_1 = 120 \text{ mm}$$

$$R_d = k_{mod} \cdot \frac{R_k}{1,1} = 0,9 \cdot \frac{2,583}{1,1} = 2,11 \text{ kN}$$

$$n = \frac{F_d}{R_d} = \frac{3,52}{2,11} = 1,67 = 2 \text{ čavla}$$

$$\text{Dokaz: } \frac{F_d}{n \cdot R_d} = \frac{3,52}{2 \cdot 2,11} = 0,83 < 1 \quad (83\%)$$

Konstruktivni zahtjevi – minimalni razmaci:

Paralelno sa vlakancima:

$$a_{1,req} = (5 + 5 \cdot \cos \alpha) \cdot d = 38,77 \text{ mm}$$

Okomito na vlakanca:

$$a_{2,req} = 5 \cdot d = 30 \text{ mm}$$

Od opterećenog kraja (paralelno s vlakancima):

$$a_{1,t} = (7 + 5 \cdot \cos \alpha) \cdot d = 50,77 \text{ mm}$$

Od neopterećenog ruba (okomito na vlakanca):

$$a_{2,c} = 5 \cdot d = 30 \text{ mm}$$

Od opterećenog kraja (okomito s vlakancima):

$$a_{2,t} = (5 + 2 \cdot \sin \alpha) \cdot d = 41,47 \text{ mm}$$

6.4 Detalj 4- bušeni čavli

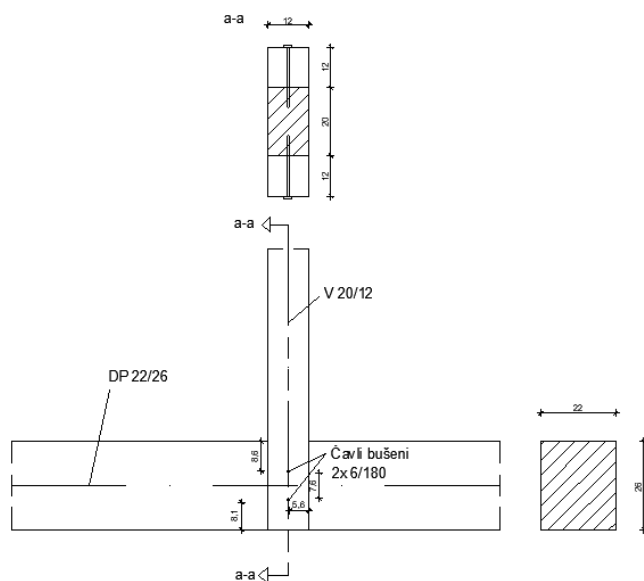

Vertikala 2x20/12
 DP 22/26 cm
 $F_d = 3,9$ kN
 Čavli 6/180 mm, $f_{u,k} = 600$ N/mm²

$$f_{h,0,k} = 0,082 \cdot (1 - 0,01 \cdot d) \cdot \rho_k = 0,082 \cdot (1 - 0,01 \cdot 6) \cdot 380 = 29,29 \text{ N/mm}^2$$

$$M_{y,k} = 0,3 \cdot f_{u,k} \cdot d^{2,6} = 0,3 \cdot 600 \cdot 6^{2,6} = 18987,41 \text{ Nmm}$$

$$R_k = \sqrt{2 \cdot M_{y,k} \cdot f_{h,0,k} \cdot d} = R_k = \sqrt{2 \cdot 18987,41 \cdot 29,29 \cdot 6} = 2583,35 \text{ N}$$

Kontrola debljine- bočna drva

$$t_{REQ} = 9 \cdot d = 54 \text{ mm}$$

$$t_{REQ} = 54 \text{ mm} < t_1 = 120 \text{ mm}$$

$$R_d = k_{mod} \cdot \frac{R_k}{1,1} = 0,9 \cdot \frac{2,583}{1,1} = 2,11 \text{ kN}$$

$$n = \frac{F_d}{R_d} = \frac{3,9}{2,11} = 1,85 = 2 \text{ čavla}$$

$$\text{Dokaz: } \frac{F_d}{n \cdot R_d} = \frac{3,9}{2 \cdot 2,11} = 0,92 < 1 \quad (92\%)$$

Konstruktivni zahtjevi – minimalni razmaci:

Paralelno sa vlakancima:

$$a_{1,req} = (5 + 5 \cdot \cos \alpha) \cdot d = 30 \text{ mm}$$

Okomito na vlakanca:

$$a_{2,req} = 5 \cdot d = 30 \text{ mm}$$

Od opterećenog kraja (paralelno s vlakancima):

$$a_{1,t} = (7 + 5 \cdot \cos \alpha) \cdot d = 42 \text{ mm}$$

Od neopterećenog ruba (okomito na vlakanca):

$$a_{2,c} = 5 \cdot d = 30 \text{ mm}$$

Od opterećenog kraja (okomito s vlakancima):

$$a_{2,t} = (5 + 2 \cdot \sin \alpha) \cdot d = 42 \text{ mm}$$

6.5 Detalj 5- jednostruki zasjek i tijesno ugrađeni vijci

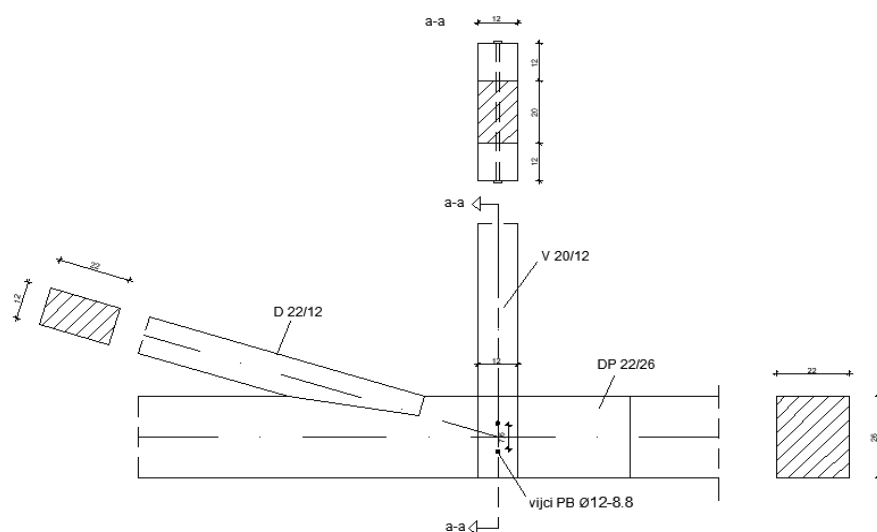

$$t_{v,max} = \frac{h}{6} = \frac{28}{6} = 4,7 \text{ cm}$$

$$t_v = 4 \text{ cm} < 4,7 \text{ cm}$$

Osiguranje M12- konstruktivno

$$f_{c, \alpha, d} = \frac{f_{c, 0, d}}{\sqrt{\left(\frac{f_{c, 0, d}}{2 \cdot f_{c, 90, d}} \cdot \sin^2 \alpha\right)^2 + \left(\frac{f_{c, 0, d}}{2 \cdot f_{v, d}} \cdot \cos \alpha \cdot \sin \alpha\right)^2 + \cos^4 \alpha}}$$

$$f_{c, \alpha, d} = \frac{16,62}{\sqrt{\left(\frac{16,62}{2 \cdot 1,87} \cdot \sin^2 24\right)^2 + \left(\frac{16,62}{2 \cdot 2,77} \cdot \cos 24 \cdot \sin 24\right)^2 + \cos^4 24}}$$

$$f_{c, \alpha, d} = 10,55 \text{ N/mm}^2$$

$$A_1 = \frac{b_1 \cdot t_{v,1}}{\cos \alpha} = \frac{22 \cdot 4}{\cos 24} = 96,33 \text{ cm}^2$$

$$\sigma'_{1,d} = \frac{N_{c,d} \cdot \cos \alpha}{A_1} = \frac{89,46 \cdot \cos 24}{96,33} \cdot 10 = 8,484 \text{ N/mm}$$

$$\text{Dokaz: } \frac{\sigma'_{1,d}}{f_{c, \alpha, d}} = \frac{8,484}{10,55} = 0,8 < 1 \quad (80\%)$$

Tijesno ugrađeni vijci PBφ12/10.9

$$f_{u,k} = 1000 \text{ N/mm}^2$$

$$F_d = 22,9 \text{ kN}$$

$$f_{h,0,k} = 0,082 \cdot (1 - 0,01 \cdot d) \cdot \rho_k = 0,082 \cdot (1 - 0,01 \cdot 12) \cdot 38 - 0 = 27,42 \text{ N/mm}^2$$

$$k_{90} = 1,35 + 0,015 \cdot d = 1,35 + 0,015 \cdot 12 = 1,53$$

$$f_{h,\alpha,k} = \frac{f_{h,0,k}}{k_{90} \cdot \sin^2 \alpha + \cos^2 \alpha} = \frac{27,42}{1,53 \cdot \sin^2(73^\circ) + \cos^2(73^\circ)} = 18,47 \text{ N/mm}^2$$

$$M_{y,k} = 0,3 \cdot f_{u,k} \cdot d^{2,6} = 0,3 \cdot 1000 \cdot 12^{2,6} = 191863,56 \text{ Nmm}$$

$$R_k = \sqrt{2 \cdot M_{y,k} \cdot f_{h,\alpha,k} \cdot d} = R_k = \sqrt{2 \cdot 191863,56 \cdot 18,47 \cdot 12} = 9222,22 \text{ N}$$

$$\beta = \frac{f_{h,\alpha,k}}{f_{h,0,k}} = \frac{18,47}{27,42} = 0,674$$

Kontrola debljine- bočna drva

$$t_{REQ} = 1,15 \cdot \left(\sqrt{\frac{\beta}{1 + \beta}} \cdot 2 + 2 \right) \cdot \sqrt{\frac{M_{y,k}}{f_{h,\alpha,k} \cdot d}} = 1,15 \cdot \left(\sqrt{\frac{0,674}{1 + 0,674}} \cdot 2 + 2 \right) \cdot \sqrt{\frac{191863,56}{18,42 \cdot 12}} =$$

$$110,61 \text{ mm}$$

$$t_{REQ} = 110,61 \text{ mm} < t_1 = 120 \text{ mm}$$

$$R_d = k_{mod} \cdot \frac{R_k}{1,1} = 0,9 \cdot \frac{9,222}{1,1} = 7,55 \text{ kN}$$

$$n = \frac{F_d}{R_d} = \frac{22,9}{2 \cdot 7,55} = 1,52 = 2 \text{ vijka}$$

Smanjenje zbog većeg broja vijaka u nizu (2 vijka – u smjeru sile; a1 = 100 mm)

$$n_{ef} = \left[\min \left\{ n; n^{0,9} \cdot \sqrt[4]{\frac{a_1}{10 \cdot d}} \right\} \right] \cdot \frac{90 - \alpha}{90} + n \cdot \frac{\alpha}{90}$$

$$n_{ef} = \left[\min \left\{ 2; 2^{0,9} \cdot \sqrt[4]{\frac{100}{10 \cdot 12}} \right\} \right] \cdot \frac{90 - 73}{90} + 2 \cdot \frac{73}{90}$$

$$n_{ef} = 1,96$$

$$\text{Dokaz: } \frac{F_d}{R_{d,OOT}} = \frac{22,9}{1 \cdot 2 \cdot 1,96 \cdot 7,55} = 0,77 < 1,0 \Rightarrow (R_{d,TOT} = 1 \text{ red} \cdot 2 \text{ reza} \cdot n_{ef} \cdot R_d)$$

Konstruktivni zahtjevi – minimalni razmaci:

Paralelno sa vlakancima:

$$a_{1,req} = (3 + 2 \cdot \cos \alpha) \cdot d = 43,02 \text{ mm}$$

Okomito na vlakanca:

$$a_{2,req} = 3 \cdot d = 36 \text{ mm}$$

Od opterećenog kraja (paralelno s vlakancima):

$$a_{1,t} = 7 \cdot d = 84 \text{ mm}$$

Od neopterećenog ruba (okomito na vlakanca):

$$a_{2,c} = 3 \cdot d = 36 \text{ mm}$$

Od opterećenog kraja (okomito s vlakancima):

$$a_{2,t} = 3 \cdot d = 36 \text{ mm}$$

6.6 Detalj 6- jednostruki zasjek i tijesno ugrađeni vijci

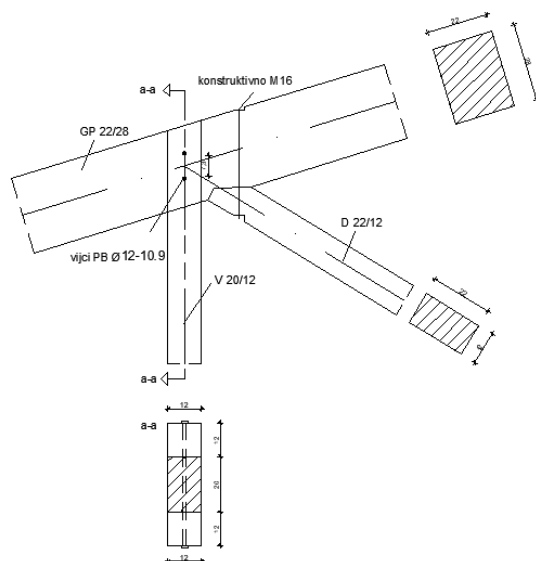

$$t_{v,max} = \frac{h}{4} = \frac{26}{4} = 6,5 \text{ cm}$$

$$t_v = 6 \text{ cm} < 6,5 \text{ cm}$$

Osiguranje M12- konstruktivno

$$f_{c,\alpha,d} = \frac{f_{c,o,d}}{\sqrt{\left(\frac{f_{c,o,d}}{2 \cdot f_{c,90,d}} \cdot \sin^2 \alpha\right)^2 + \left(\frac{f_{c,o,d}}{2 \cdot f_{v,d}} \cdot \cos \alpha \cdot \sin \alpha\right)^2 + \cos^4 \alpha}}$$

$$f_{c,\alpha,d} = \frac{16,62}{\sqrt{\left(\frac{16,62}{2 \cdot 1,87} \cdot \sin^2 8,5\right)^2 + \left(\frac{16,62}{2 \cdot 2,77} \cdot \cos 8,5 \cdot \sin 8,5\right)^2 + \cos^4 8,5}}$$

$$f_{c,\alpha,d} = 15,44 \text{ N/mm}^2$$

$$A_1 = \frac{b_1 \cdot t_{v,1}}{\cos \alpha} = \frac{22 \cdot 6}{\cos 8,5} = 44,49 \text{ cm}^2$$

$$\sigma_{1,d} = \frac{N_{c,d} \cdot \cos \alpha}{A_1} = \frac{61,93 \cdot \cos 8,5}{44,49} \cdot 10 = 13,77 \text{ N/mm}$$

$$\text{Dokaz: } \frac{\sigma_{1,d}}{f_{c,\alpha,d}} = \frac{13,77}{15,44} = 0,89 < 1 \quad (89\%)$$

Tijesno ugrađeni vijci PBφ12/8.8

$$f_{u,k}=800 \text{ N/mm}^2$$

$$F_d=22,17 \text{ kN}$$

$$f_{h,0,k} = 0,082 \cdot (1 - 0,01 \cdot d) \cdot \rho_k = 0,082 \cdot (1 - 0,01 \cdot 12) \cdot 380 = 27,42 \text{ N/mm}^2$$

$$k_{90} = 1,35 + 0,015 \cdot d = 1,35 + 0,015 \cdot 12 = 1,53$$

$$f_{h,\alpha,k} = \frac{f_{h,0,k}}{k_{90} \cdot \sin^2 \alpha + \cos^2 \alpha} = \frac{27,42}{1,53 \cdot \sin^2(90^\circ) + \cos^2(90^\circ)} = 17,92 \text{ N/mm}^2$$

$$M_{y,k} = 0,3 \cdot f_{u,k} \cdot d^{2,6} = 0,3 \cdot 800 \cdot 12^{2,6} = 153490,85 \text{ Nmm}$$

$$R_k = \sqrt{2 \cdot M_{y,k} \cdot f_{h,\alpha,k} \cdot d} = R_k = \sqrt{2 \cdot 153490,85 \cdot 17,92 \cdot 12} = 8124,86 \text{ N}$$

$$\beta = \frac{f_{h,\alpha,k}}{f_{h,0,k}} = \frac{17,92}{27,42} = 0,654$$

Kontrola debljine- bočna drva

$$t_{REQ} = 1,15 \cdot \left(\sqrt{\frac{\beta}{1 + \beta}} \cdot 2 + 2 \right) \cdot \sqrt{\frac{M_{y,k}}{f_{h,\alpha,k} \cdot d}} = 1,15 \cdot \left(\sqrt{\frac{0,654}{1 + 0,654}} \cdot 2 + 2 \right) \cdot \sqrt{\frac{153490,85}{17,92 \cdot 12}} =$$

$$100,09 \text{ mm}$$

$$t_{REQ} = 100,09 \text{ mm} < t_1 = 120 \text{ mm}$$

$$R_d = k_{mod} \cdot \frac{R_k}{1,1} = 0,9 \cdot \frac{8,125}{1,1} = 6,65 \text{ kN}$$

$$n = \frac{F_d}{R_d} = \frac{22,17}{2 \cdot 6,65} = 1,67 = 2 \text{ vijka}$$

Smanjenje zbog većeg broja vijaka u nizu (4 vijka – u smjeru sile; a1 = 100 mm)

$$n_{ef} = \left[\min \left\{ n; n^{0,9} \cdot \sqrt[4]{\frac{a_1}{10 \cdot d}} \right\} \right] \cdot \frac{90 - \alpha}{90} + n \cdot \frac{\alpha}{90}$$

$$n_{ef} = \left[\min \left\{ 2; 2^{0,9} \cdot \sqrt[4]{\frac{100}{10 \cdot 12}} \right\} \right] \cdot \frac{90 - 90}{90} + 2 \cdot \frac{90}{90}$$

$$n_{ef} = 2$$

$$\text{Dokaz: } \frac{F_d}{R_{d,OOT}} = \frac{22,17}{1 \cdot 2 \cdot 2 \cdot 6,65} = 0,83 < 1,0 \Rightarrow (R_{d,TOT} = 1red \cdot 2reza \cdot n_{ef} \cdot R_d)$$

Konstruktivni zahtjevi – minimalni razmaci:

Paralelno sa vlakancima:

$$a_{1,req} = (3 + 2 \cdot \cos \alpha) \cdot d = 36 \text{ mm}$$

Okomito na vlakanca:

$$a_{2,req} = 3 \cdot d = 36 \text{ mm}$$

Od opterećenog kraja (paralelno s vlakancima):

$$a_{1,t} = 7d = 84 \text{ mm}$$

Od neopterećenog ruba (okomito na vlakanca):

$$a_{2,c} = 3 \cdot d = 36 \text{ mm}$$

Od opterećenog kraja (okomito s vlakancima):

$$a_{2,t} = 3 \cdot d = 36 \text{ mm}$$

6.7 Detalj 7- tijesno ugrađeni vijci

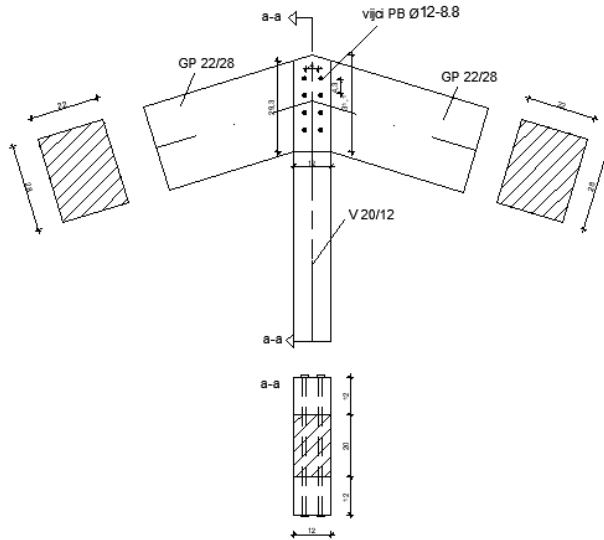

Tijesno ugrađeni vijci PB ϕ 12/8.8

$$f_{u,k} = 800 \text{ N/mm}^2$$

$$F_d = 91,04 \text{ kN}$$

$$f_{h,0,k} = 0,082 \cdot (1 - 0,01 \cdot d) \cdot \rho_k = 0,082 \cdot (1 - 0,01 \cdot 12) \cdot 380 = 27,42 \text{ N/mm}^2$$

$$k_{90} = 1,35 + 0,015 \cdot d = 1,35 + 0,015 \cdot 12 = 1,53$$

$$f_{h,\alpha,k} = \frac{f_{h,0,k}}{k_{90} \cdot \sin^2 \alpha + \cos^2 \alpha} = \frac{27,42}{1,53 \cdot \sin^2(73^\circ) + \cos^2(73^\circ)} = 18,48 \text{ N/mm}^2$$

$$M_{y,k} = 0,3 \cdot f_{u,k} \cdot d^{2,6} = 0,3 \cdot 800 \cdot 12^{2,6} = 153490,85 \text{ Nmm}$$

$$R_k = \sqrt{2 \cdot M_{y,k} \cdot f_{h,\alpha,k} \cdot d} = R_k = \sqrt{2 \cdot 153490,85 \cdot 18,48 \cdot 12} = 7899,57 \text{ N}$$

$$\beta = \frac{f_{h,\alpha,k}}{f_{h,0,k}} = \frac{18,48}{27,42} = 0,674$$

Kontrola debljine- bočna drva

$$t_{REQ} = 1,15 \cdot \left(\sqrt{\frac{\beta}{1 + \beta}} \cdot 2 + 2 \right) \cdot \sqrt{\frac{M_{y,k}}{f_{h,\alpha,k} \cdot d}} = 1,15 \cdot \left(\sqrt{\frac{0,674}{1 + 0,674}} \cdot 2 + 2 \right) \cdot \sqrt{\frac{153490,85}{18,48 \cdot 12}} = 98,91 \text{ mm}$$

$$t_{REQ} = 98,91 \text{ mm} < t_1 = 120 \text{ mm}$$

$$R_d = k_{mod} \cdot \frac{R_k}{1,1} = 0,9 \cdot \frac{7,899}{1,1} = 6,46 \text{ kN}$$

$$n = \frac{F_d}{R_d} = \frac{91,04}{2 \cdot 6,46} = 7,04 = 8 \text{ vijaka}$$

Smanjenje zbog većeg broja vijaka u nizu (4 vijka – u smjeru sile; a1 = 100 mm)

$$n_{ef} = \left[\min \left\{ n; n^{0,9} \cdot \sqrt[4]{\frac{a_1}{10 \cdot d}} \right\} \right] \cdot \frac{90 - \alpha}{90} + n \cdot \frac{\alpha}{90}$$

$$n_{ef} = \left[\min \left\{ 4; 4^{0,9} \cdot \sqrt[4]{\frac{100}{10 \cdot 12}} \right\} \right] \cdot \frac{90 - 73}{90} + 2 \cdot \frac{73}{90}$$

$$n_{ef} = 2,25$$

$$\text{Dokaz: } \frac{F_d}{R_{d,OOT}} = \frac{22,17}{1 \cdot 2 \cdot 2,25 \cdot 6,65} = 0,74 < 1,0 \Rightarrow (R_{d,TOT} = 1red \cdot 2reza \cdot n_{ef} \cdot R_d)$$

Konstruktivni zahtjevi – minimalni razmaci:

Paralelno sa vlakancima:

$$a_{1,req} = (3 + 2 \cdot \cos \alpha) \cdot d = 43,02 \text{ mm}$$

Okomito na vlakanca:

$$a_{2,req} = 3 \cdot d = 36 \text{ mm}$$

Od opterećenog kraja (paralelno s vlakancima):

$$a_{1,t} = 7 \cdot d = 84 \text{ mm}$$

Od neopterećenog ruba (okomito na vlakanca):

$$a_{2,c} = 5 \cdot d = 36 \text{ mm}$$

Od opterećenog kraja (okomito s vlakancima):

$$a_{2,t} = 3 \cdot d = 36 \text{ mm}$$

Tijesno ugrađeni vijci PBφ12/8.8

$$f_{u,k}=800 \text{ N/mm}^2$$

$$F_d=91,04 \text{ kN}$$

$$f_{h,0,k} = 0,082 \cdot (1 - 0,01 \cdot d) \cdot \rho_k = 0,082 \cdot (1 - 0,01 \cdot 12) \cdot 380 = 27,42 \text{ N/mm}^2$$

$$k_{90} = 1,35 + 0,015 \cdot d = 1,35 + 0,015 \cdot 12 = 1,53$$

$$f_{h,\alpha,k} = \frac{f_{h,0,k}}{k_{90} \cdot \sin^2 \alpha + \cos^2 \alpha} = \frac{27,42}{1,53 \cdot \sin^2(90^\circ) + \cos^2(90^\circ)} = 17,92 \text{ N/mm}^2$$

$$M_{y,k} = 0,3 \cdot f_{u,k} \cdot d^{2,6} = 0,3 \cdot 800 \cdot 12^{2,6} = 153490,85 \text{ Nmm}$$

$$R_k = \sqrt{2 \cdot M_{y,k} \cdot f_{h,\alpha,k} \cdot d} = R_k = \sqrt{2 \cdot 153490,85 \cdot 17,92 \cdot 12} = 8124,86 \text{ N}$$

$$\beta = \frac{f_{h,\alpha,k}}{f_{h,0,k}} = \frac{17,92}{27,42} = 0,654$$

Kontrola debljine- bočna drva

$$t_{REQ} = 1,15 \cdot \left(\sqrt{\frac{\beta}{1 + \beta}} \cdot 2 + 2 \right) \cdot \sqrt{\frac{M_{y,k}}{f_{h,\alpha,k} \cdot d}} = 1,15 \cdot \left(\sqrt{\frac{0,654}{1 + 0,654}} \cdot 2 + 2 \right) \cdot \sqrt{\frac{153490,85}{17,92 \cdot 12}} =$$

$$100,09 \text{ mm}$$

$$t_{REQ} = 100,09 \text{ mm} < t_1 = 120 \text{ mm}$$

$$R_d = k_{mod} \cdot \frac{R_k}{1,1} = 0,9 \cdot \frac{8,125}{1,1} = 6,65 \text{ kN}$$

$$n = \frac{F_d}{R_d} = \frac{86,92}{2 \cdot 6,65} = 6,54 = 8 \text{ vijaka}$$

Smanjenje zbog većeg broja vijaka u nizu (4 vijka – u smjeru sile; a1 = 100 mm)

$$n_{ef} = \left[\min \left\{ n; n^{0,9} \cdot \sqrt[4]{\frac{a_1}{10 \cdot d}} \right\} \right] \cdot \frac{90 - \alpha}{90} + n \cdot \frac{\alpha}{90}$$

$$n_{ef} = \left[\min \left\{ 4; 4^{0,9} \cdot \sqrt[4]{\frac{100}{10 \cdot 12}} \right\} \right] \cdot \frac{90 - 90}{90} + 2 \cdot \frac{90}{90}$$

$$n_{ef} = 4$$

$$\text{Dokaz: } \frac{F_d}{R_{d,OOT}} = \frac{86,92}{2 \cdot 2 \cdot 4 \cdot 6,65} = 0,82 < 1,0 \Rightarrow (R_{d,TOT} = 1red \cdot 2reza \cdot n_{ef} \cdot R_d)$$

Konstruktivni zahtjevi – minimalni razmaci:

Paralelno sa vlakancima:

$$a_{1,req} = (3 + 2 \cdot \cos \alpha) \cdot d = 36 \text{ mm}$$

Okomito na vlakanca:

$$a_{2,req} = 3 \cdot d = 36 \text{ mm}$$

Od opterećenog kraja (paralelno s vlakancima):

$$a_{1,t} = 7 \cdot d = 84 \text{ mm}$$

Od neopterećenog ruba (okomito na vlakanca):

$$a_{2,c} = 3 \cdot d = 36 \text{ mm}$$

Od opterećenog kraja (okomito s vlakancima):

$$a_{2,t} = 3 \cdot d = 36 \text{ mm}$$

7. Vatrootpornost elemenata

Proračun nosivosti konstrukcije uslijed djelovanja požara u trajanju od 30 min po EC5.
Dijagrami reznih sila za najkritičniju kombinaciju: 1,0 G + 0,2 W2

M-dijagram

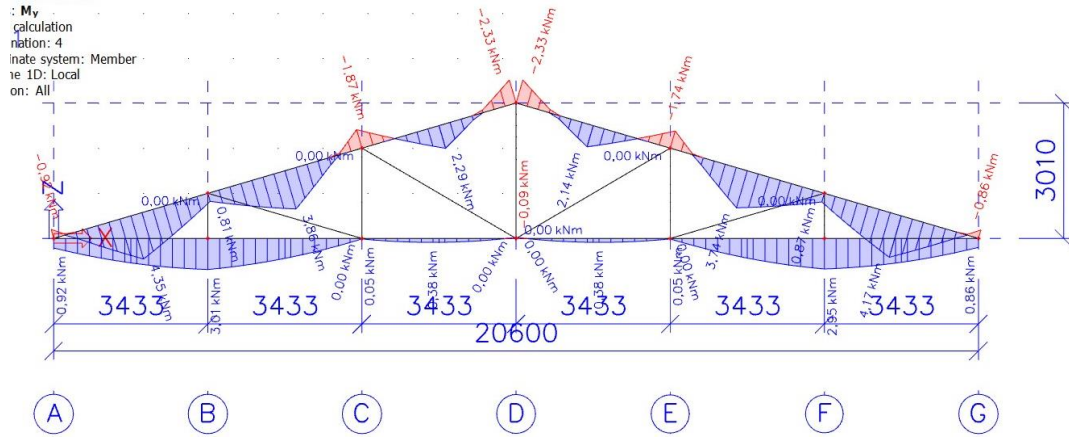

V-dijagram

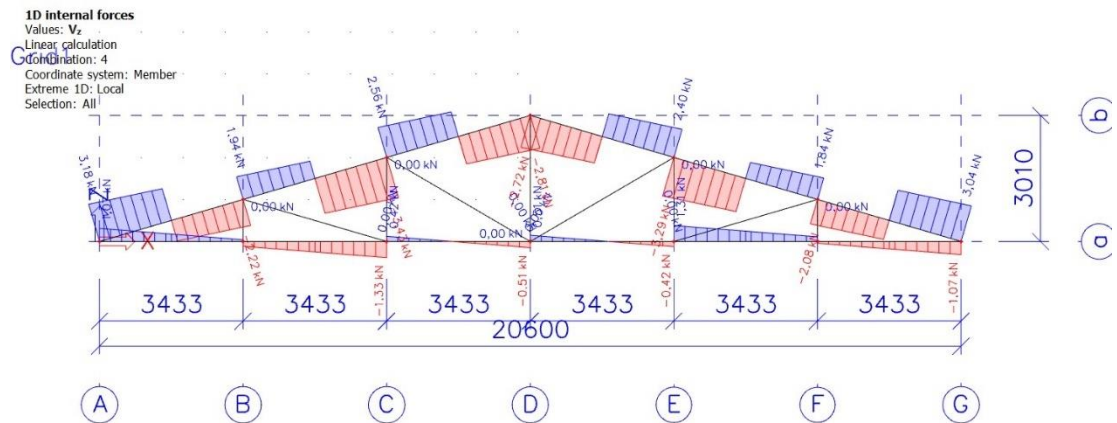

N-dijagram

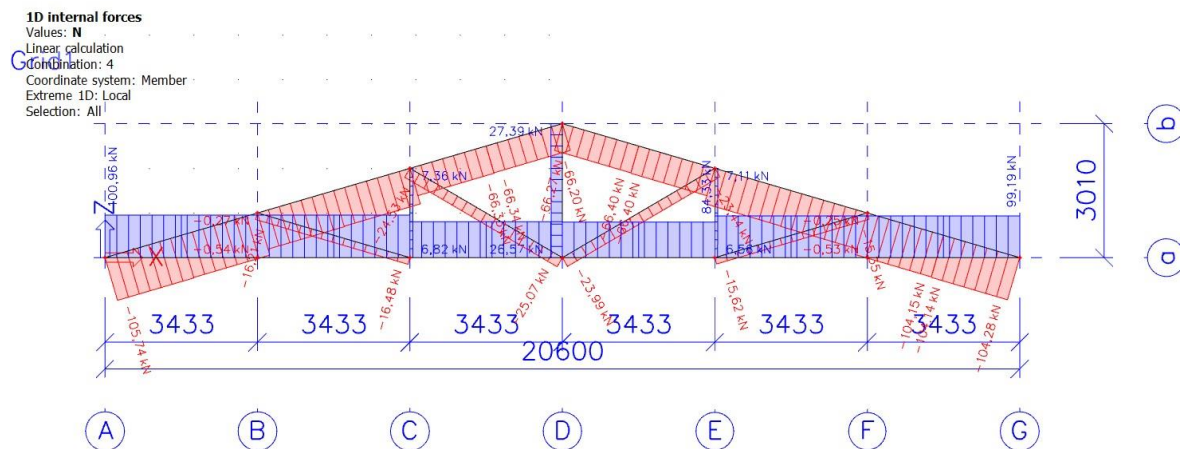

PUNO DRVO $\rho = 380 \text{ kg/m}^3 \rightarrow \beta_n = 0,8 \text{ mm/min}$ $\beta_o = 0,65 \text{ mm/min}$

7.1 Vatrootpornost gornjeg pojasa

GORNJI POJAS – b/h=22/28 cm

$$M_{d,fi} = 4,35 \text{ kNm}$$

$$N_{d,fi} = 105,74 \text{ kN}$$

Gubitak presjeka:

$$d_{fi} = t_f \cdot \beta_n = 30 \cdot 0,8 = 24 \text{ mm} = 2,4 \text{ cm}$$

Dimenzije poprečnog presjeka nakon 30 minuta požara:

$$b_{fi} = b - 2 \cdot d_{fi} = 22 - 2 \cdot 2,4 = 17,2 \text{ cm}$$

$$h_{fi} = h - 2 \cdot d_{fi} = 28 - 2 \cdot 2,4 = 23,2 \text{ cm}$$

Nagoreni opseg:

$$u_r = 2 \cdot b_{fi} + 2 \cdot h_{fi} = 2 \cdot 17,2 + 2 \cdot 23,2 = 80,8 \text{ cm}$$

Površina nagorenog presjeka:

$$A_r = b_{fi} \cdot h_{fi} = 17,2 \cdot 23,2 = 399,04 \text{ cm}^2$$

Reducirani moment otpora:

$$W_{y,r} = \frac{b_{fi} \cdot h_{fi}^2}{6} = \frac{17,2 \cdot 23,2^2}{6} = 1542,96 \text{ cm}^3$$

Proračun naprezanja nosača:

$$\sigma_{c,o,d,fi} = \frac{N_{c,o,d,fi}}{A_r} = \frac{105,74 \cdot 10^3}{399,04 \cdot 10^2} = 2,65 \text{ N/mm}^2$$

$$\sigma_{m,y,d,fi} = \frac{M_{y,d}}{W_{y,r}} = \frac{4,35 \cdot 10^6}{1542,96 \cdot 10^3} = 2,82 \text{ N/mm}^2$$

Karakteristične vrijednosti čvrstoća i modula elastičnosti:

$$f_{m,k} = 30 \text{ N/mm}^2$$

$$f_{t,0,k} = 19 \text{ N/mm}^2$$

$$f_{c,0,k} = 24 \text{ N/mm}^2$$

$$f_{v,k} = 4 \text{ N/mm}^2$$

$$E_{o,mean} = 12000 \text{ N/mm}^2$$

$$G_{mean} = 750 \text{ N/mm}^2$$

$$E_{0,05} = \frac{2}{3} \cdot E_{o,mean} = \frac{2}{3} \cdot 12000 = 8000 \text{ N/mm}^2$$

$$G_{0,05} = \frac{2}{3} \cdot G_{mean} = \frac{2}{3} \cdot 750 = 500 \text{ N/mm}^2$$

Proračunske vrijednosti čvrstoća i modula elastičnosti uz vrijednost koeficijenata modifikacije:

$k_{fi} = 1,25$ prijelaz na 20% fraktilu za LLD

$\gamma_{m,fi} = 1,0$ preporučena vrijednost parcijalnog faktora sigurnosti tijekom požara

Savojna čvrstoća: $k_{mod,m,fi} = 1 - \frac{1}{200} * \frac{u_r}{A_r} = 1 - \frac{1}{200} * \frac{80,08 * 10^{-2}}{399,04 * 10^{-4}} = 0,899$

Tlačna čvrstoća: $k_{mod,c,fi} = 1 - \frac{1}{125} * \frac{u_r}{A_r} = 1 - \frac{1}{125} * \frac{80,08 * 10^{-2}}{399,04 * 10^{-4}} = 0,838$

Vlačna čvrstoća i za E i G module:

$$k_{mod,t,fi} = k_{mod,E,fi} = k_{mod,G,fi} = 1 - \frac{1}{330} * \frac{u_r}{A_r} = 1 - \frac{1}{330} * \frac{80,08 * 10^{-2}}{399,04 * 10^{-4}} = 0,939$$

Vrijednosti:

$$f_{m,d,fi} = k_{mod,m,fi} * k_{fi} * \frac{f_{m,k}}{\gamma_{m,fi}} = 0,899 * 1,25 * \frac{30}{1} = 33,71 \text{ N/mm}^2$$

$$f_{c,d,fi} = k_{mod,c,fi} * k_{fi} * \frac{f_{m,k}}{\gamma_{m,fi}} = 0,838 * 1,25 * \frac{30}{1} = 31,43 \text{ N/mm}^2$$

$$E_{d,fi} = k_{mod,E,fi} * k_{fi} * \frac{E_{0,05}}{\gamma_{m,fi}} = 0,939 * 1,25 * \frac{8000}{1} = 9386,41 \text{ N/mm}^2$$

$$G_{d,fi} = k_{mod,G,fi} * k_{fi} * \frac{\frac{2}{3} G_{05}}{\gamma_{m,fi}} = 0,939 * 1,25 * \frac{\frac{2}{3} * 500}{1} = 391,1 \text{ N/mm}^2$$

Koeficijent izbočavanja oko osi: $k_{crit} = 1,0$

Dokaz nosivosti i stabilnosti:

$$\frac{\sigma_{c,0,d}}{k_c * f_{c,0,d}} + \frac{\sigma_{m,d}}{k_{crit} * f_{m,d}} = \frac{2,65}{0,699 * 31,43} + \frac{2,82}{1 * 33,71} = 0,204 < 1$$

7.2 Vatrootpornost donjeg pojasa

DONJI POJAS- b/h=22/26 cm

$$M_{d,fi} = 3,01 \text{ kNm}$$

$$N_{d,fi} = 100,96$$

Gubitak presjeka:

$$d_{fi} = t_f \cdot \beta_n = 30 \cdot 0,8 = 24 \text{ mm} = 2,4 \text{ cm}$$

Dimenzije poprečnog presjeka nakon 30 minuta požara:

$$b_{fi} = b - 2 \cdot d_{fi} = 22 - 2 \cdot 2,4 = 17,2 \text{ cm}$$

$$h_{fi} = h - 2 \cdot d_{fi} = 26 - 2 \cdot 2,4 = 21,2 \text{ cm}$$

Nagoreni opseg:

$$u_r = 2 \cdot b_{fi} + 2 \cdot h_{fi} = 2 \cdot 17,2 + 2 \cdot 21,2 = 76,8 \text{ cm}$$

Površina nagorenog presjeka:

$$A_r = b_{fi} \cdot h_{fi} = 17,2 \cdot 21,2 = 364,64 \text{ cm}^2$$

Reducirani moment otpora:

$$W_{y,r} = \frac{b_{fi} \cdot h_{fi}^2}{6} = \frac{17,2 \cdot 21,2^2}{6} = 1288,39 \text{ cm}^3$$

Proračun naprezanja nosača:

$$\sigma_{c,o,d,fi} = \frac{N_{c,o,d,fi}}{A_r} = \frac{100,96 \cdot 10^3}{364,64 \cdot 10^2} = 2,77 \text{ N/mm}^2$$

$$\sigma_{m,y,d,fi} = \frac{M_{y,d}}{W_{y,r}} = \frac{3,01 \cdot 10^6}{1288,39 \cdot 10^3} = 2,34 \text{ N/mm}^2$$

Karakteristične vrijednosti čvrstoća i modula elastičnosti:

$$f_{m,k} = 30 \text{ N/mm}^2$$

$$f_{t,0,k} = 19 \text{ N/mm}^2$$

$$f_{c,0,k} = 24 \text{ N/mm}^2$$

$$f_{v,k} = 4 \text{ N/mm}^2$$

$$E_{o,mean} = 12000 \text{ N/mm}^2$$

$$G_{mean} = 750 \text{ N/mm}^2$$

$$E_{0,05} = \frac{2}{3} \cdot E_{o,mean} = \frac{2}{3} \cdot 12000 = 8000 \text{ N/mm}^2$$

$$G_{0,05} = \frac{2}{3} \cdot G_{mean} = \frac{2}{3} \cdot 750 = 500 \text{ N/mm}^2$$

Proračunske vrijednosti čvrstoća i modula elastičnosti uz vrijednost koeficijenata modifikacije:

$k_{fi} = 1,25$ prijelaz na 20% fraktilu za LLD

$\gamma_{m,fi} = 1,0$ preporučena vrijednost parcijalnog faktora sigurnosti tijekom požara

$$\text{Savojna čvrstoća: } k_{mod,m,fi} = 1 - \frac{1}{200} * \frac{u_r}{A_r} = 1 - \frac{1}{200} * \frac{76,8 * 10^{-2}}{364,64 * 10^{-4}} = 0,895$$

$$\text{Tlačna čvrstoća: } k_{mod,c,fi} = 1 - \frac{1}{125} * \frac{u_r}{A_r} = 1 - \frac{1}{125} * \frac{76,8 * 10^{-2}}{364,64 * 10^{-4}} = 0,832$$

Vlačna čvrstoća i za E i G module:

$$k_{mod,t,fi} = k_{mod,E,fi} = k_{mod,G,fi} = 1 - \frac{1}{330} * \frac{u_r}{A_r} = 1 - \frac{1}{330} * \frac{76,8 * 10^{-2}}{364,64 * 10^{-4}} = 0,936$$

Vrijednosti:

$$f_{m,d,fi} = k_{mod,m,fi} * k_{fi} * \frac{f_{m,k}}{\gamma_{m,fi}} = 0,895 * 1,25 * \frac{30}{1} = 33,55 \text{ N/mm}^2$$

$$f_{c,d,fi} = k_{mod,c,fi} * k_{fi} * \frac{f_{m,k}}{\gamma_{m,fi}} = 0,832 * 1,25 * \frac{30}{1} = 31,17 \text{ N/mm}^2$$

$$E_{d,fi} = k_{mod,E,fi} * k_{fi} * \frac{E_{0,05}}{\gamma_{m,fi}} = 0,936 * 1,25 * \frac{8000}{1} = 9361,76 \text{ N/mm}^2$$

$$G_{d,fi} = k_{mod,G,fi} * k_{fi} * \frac{\frac{2}{3} G_{05}}{\gamma_{m,fi}} = 0,936 * 1,25 * \frac{\frac{2}{3} * 500}{1} = 390,1 \text{ N/mm}^2$$

Koeficijent izbočavanja oko osi: $k_{crit} = 1,0$

Dokaz nosivosti i stabilnosti:

$$\frac{\sigma_{c,0,d}}{k_c * f_{c,0,d}} + \frac{\sigma_{m,d}}{k_{crit} * f_{m,d}} = \frac{2,77}{0,699 * 31,17} + \frac{2,34}{1 * 33,55} = 0,196 < 1$$

7.3 Vatrootpornost dijagonala

DIJAGONALE- b/h=20/12 cm

$$M_{d,fi} = 0 \text{ kNm}$$

$$N_{d,fi} = 25,07 \text{ kN}$$

Gubitak presjeka:

$$dfi = tf * \beta n = 30 * 0,8 = 24 \text{ mm} = 2,4 \text{ cm}$$

Dimenzije poprečnog presjeka nakon 30 minuta požara:

$$b_{fi} = b - 2 * dfi = 22 - 2 * 2,4 = 17,2 \text{ cm}$$

$$h_{fi} = h - 2 * dfi = 12 - 2 * 2,4 = 7,2 \text{ cm}$$

Nagoreni opseg:

$$ur = 2 * b_{fi} + 2 * h_{fi} = 2 * 17,2 + 2 * 7,2 = 48,8 \text{ cm}$$

Površina nagorenog presjeka:

$$Ar = b_{fi} * h_{fi} = 17,2 * 7,2 = 123,84 \text{ cm}^2$$

Reducirani moment otpora:

$$W_{y,r} = \frac{b_{fi} * h_{fi}^2}{6} = \frac{17,2 * 7,2^2}{6} = 148,61 \text{ cm}^3$$

Proračun naprezanja nosača:

$$\sigma_{c,o,d,fi} = \frac{N_{c,o,d,fi}}{A_r} = \frac{25,07 * 10^3}{123,84 * 10^2} = 2,02 \text{ N/mm}^2$$

$$\sigma_{m,y,d,fi} = \frac{M_{y,d}}{W_{y,r}} = \frac{0 * 10^6}{148,61 * 10^3} = 0 \text{ N/mm}^2$$

Karakteristične vrijednosti čvrstoća i modula elastičnosti:

$$f_{m,k} = 30 \text{ N/mm}^2$$

$$f_{t,0,k} = 19 \text{ N/mm}^2$$

$$f_{c,0,k} = 24 \text{ N/mm}^2$$

$$f_{v,k} = 4 \text{ N/mm}^2$$

$$E_{o,mean} = 12000 \text{ N/mm}^2$$

$$G_{mean} = 750 \text{ N/mm}^2$$

$$E_{0,05} = \frac{2}{3} * E_{o,mean} = \frac{2}{3} * 12000 = 8000 \text{ N/mm}^2$$

$$G_{0,05} = \frac{2}{3} * G_{mean} = \frac{2}{3} * 750 = 500 \text{ N/mm}^2$$

Proračunske vrijednosti čvrstoća i modula elastičnosti uz vrijednost koeficijenta modifikacije:

$k_{fi} = 1,25$ prijelaz na 20% fraktilu za LLD

$\gamma_{m,fi} = 1,0$ preporučena vrijednost parcijalnog faktora sigurnosti tijekom požar

$$\text{Savojna čvrstoća: } k_{mod,m,fi} = 1 - \frac{1}{200} * \frac{ur}{A_r} = 1 - \frac{1}{200} * \frac{48,8 * 10^{-2}}{123,84 * 10^{-4}} = 0,803$$

Tlačna čvrstoća: $k_{mod,c,fi} = 1 - \frac{1}{125} * \frac{u_r}{A_r} = 1 - \frac{1}{125} * \frac{48,8 * 10^{-2}}{123,84 * 10^{-4}} = 0,68$

Vlačna čvrstoća i za E i G module:

$$k_{mod,t,fi} = k_{mod,E,fi} = k_{mod,G,fi} = 1 - \frac{1}{330} * \frac{u_r}{A_r} = 1 - \frac{1}{330} * \frac{48,8 * 10^{-2}}{123,84 * 10^{-4}} = 0,881$$

Vrijednosti:

$$f_{m,d,fi} = k_{mod,m,fi} * k_{fi} * \frac{f_{m,k}}{\gamma_{m,fi}} = 0,803 * 1,25 * \frac{30}{1} = 30,11 \text{ N/mm}^2$$

$$f_{c,d,fi} = k_{mod,c,fi} * k_{fi} * \frac{f_{m,k}}{\gamma_{m,fi}} = 0,685 * 1,25 * \frac{30}{1} = 25,68 \text{ N/mm}^2$$

$$E_{d,fi} = k_{mod,E,fi} * k_{fi} * \frac{E_{0,05}}{\gamma_{m,fi}} = 0,881 * 1,25 * \frac{8000}{1} = 8805,89 \text{ N/mm}^2$$

$$G_{d,fi} = k_{mod,G,fi} * k_{fi} * \frac{\frac{2}{3} G_{05}}{\gamma_{m,fi}} = 0,881 * 1,25 * \frac{\frac{2}{3} * 500}{1} = 366,91 \text{ N/mm}^2$$

Koeficijent izbočavanja oko osi: $k_{crit} = 1.0$

Dokaz nosivosti i stabilnosti:

$$\frac{\sigma_{c,0,d}}{k_c * f_{c,0,d}} + \frac{\sigma_{m,d}}{k_{crit} * f_{m,d}} = \frac{2,02}{0,223 * 25,68} + \frac{0}{1 * 30,11} = 0,353 < 1$$

7.4 Vatrootpornost vertikalna

VERTIKALE -b/h=20/12 cm

$$M_{d,fi} = 0 \text{ kNm}$$

$$N_{d,fi} = 27,39 \text{ kN}$$

Gubitak presjeka:

$$d_{fi} = t_f \cdot \beta_n = 30 \cdot 0,8 = 24 \text{ mm} = 2,4 \text{ cm}$$

Dimenzije poprečnog presjeka nakon 30 minuta požara:

$$b_{fi} = b - 2 \cdot d_{fi} = 20 - 2 \cdot 2,4 = 15,2 \text{ cm}$$

$$h_{fi} = h - 2 \cdot d_{fi} = 12 - 2 \cdot 2,4 = 7,2 \text{ cm}$$

Nagoreni opseg:

$$u_r = 2 \cdot b_{fi} + 2 \cdot h_{fi} = 2 \cdot 15,2 + 2 \cdot 7,2 = 44,8 \text{ cm}$$

Površina nagorenog presjeka:

$$A_r = b_{fi} \cdot h_{fi} = 15,2 \cdot 7,2 = 109,44 \text{ cm}^2$$

Reducirani moment otpora:

$$W_{y,r} = \frac{b_{fi} \cdot h_{fi}^2}{6} = \frac{15,2 \cdot 7,2^2}{6} = 131,33 \text{ cm}^3$$

Proračun naprezanja nosača:

$$\sigma_{c,o,d,fi} = \frac{N_{c,o,d,fi}}{A_r} = \frac{27,39 \cdot 10^3}{109,44 \cdot 10^2} = 2,5 \text{ N/mm}^2$$

$$\sigma_{m,y,d,fi} = \frac{M_{y,d}}{W_{y,r}} = \frac{0 \cdot 10^6}{131,33 \cdot 10^3} = 0 \text{ N/mm}^2$$

Karakteristične vrijednosti čvrstoća i modula elastičnosti:

$$f_{m,k} = 30 \text{ N/mm}^2$$

$$f_{t,0,k} = 19 \text{ N/mm}^2$$

$$f_{c,0,k} = 24 \text{ N/mm}^2$$

$$f_{v,k} = 4 \text{ N/mm}^2$$

$$E_{o,mean} = 12000 \text{ N/mm}^2$$

$$G_{mean} = 750 \text{ N/mm}^2$$

$$E_{0,05} = \frac{2}{3} \cdot E_{o,mean} = \frac{2}{3} \cdot 12000 = 8000 \text{ N/mm}^2$$

$$G_{0,05} = \frac{2}{3} \cdot G_{mean} = \frac{2}{3} \cdot 750 = 500 \text{ N/mm}^2$$

Proračunske vrijednosti čvrstoća i modula elastičnosti uz vrijednost koeficijenta modifikacije:

$k_{fi} = 1,25$ prijelaz na 20% fraktilu za LLD

$\gamma_{m,fi} = 1,0$ preporučena vrijednost parcijalnog faktora sigurnosti tijekom požara

$$\text{Savojna čvrstoća: } k_{mod,m,fi} = 1 - \frac{1}{200} \cdot \frac{u_r}{A_r} = 1 - \frac{1}{200} \cdot \frac{44,8 \cdot 10^{-2}}{109,44 \cdot 10^{-4}} = 0,795$$

Tlačna čvrstoća: $k_{\text{mod},c,fi} = 1 - \frac{1}{125} * \frac{u_r}{A_r} = 1 - \frac{1}{125} * \frac{44,8 * 10^{-2}}{109,44 * 10^{-4}} = 0,673$

Vlačna čvrstoća i za E i G module:

$$k_{\text{mod},t,fi} = k_{\text{mod},E,fi} = k_{\text{mod},G,fi} = 1 - \frac{1}{330} * \frac{u_r}{A_r} = 1 - \frac{1}{330} * \frac{44,8 * 10^{-2}}{109,44 * 10^{-4}} = 0,876$$

Vrijednosti:

$$f_{m,d,fi} = k_{\text{mod},m,fi} * k_{fi} * \frac{f_{m,k}}{\gamma_{m,fi}} = 0,795 * 1,25 * \frac{30}{1} = 29,82 \text{ N/mm}^2$$

$$f_{c,d,fi} = k_{\text{mod},c,fi} * k_{fi} * \frac{f_{m,k}}{\gamma_{m,fi}} = 0,673 * 1,25 * \frac{30}{1} = 25,22 \text{ N/mm}^2$$

$$E_{d,fi} = k_{\text{mod},E,fi} * k_{fi} * \frac{E_{0,05}}{\gamma_{m,fi}} = 0,876 * 1,25 * \frac{8000}{1} = 8759,53 \text{ N/mm}^2$$

$$G_{d,fi} = k_{\text{mod},G,fi} * k_{fi} * \frac{\frac{2}{3} G_{05}}{\gamma_{m,fi}} = 0,876 * 1,25 * \frac{\frac{2}{3} * 500}{1} = 364,98 \text{ N/mm}^2$$

Koeficijent izbočavanja oko osi: $k_{\text{crit}} = 1.0$

Dokaz nosivosti i stabilnosti:

$$\frac{\sigma_{c,0,d}}{k_c * f_{c,0,d}} + \frac{\sigma_{m,d}}{k_{\text{crit}} * f_{m,d}} = \frac{2,5}{0,220 * 25,22} + \frac{0}{1 * 29,82} = 0,451 < 1$$

7.5 Dokaz za dijagonale

PODROŽNICE -b/h=18/20 cm

$$M_{y,fi} = 11,09 \text{ kNm}$$

$$M_{z,fi} = 2,69 \text{ kNm}$$

$$V_{y,fi} = 9,86 \text{ kN}$$

$$V_{z,fi} = 2,39 \text{ kN}$$

$$N_{d,fi} = 14,89 \text{ kN}$$

Gubitak presjeka:

$$dfi = tf \cdot \beta n = 30 \cdot 0,8 = 24 \text{ mm} = 2,4 \text{ cm}$$

Dimenzije poprečnog presjeka nakon 30 minuta požara:

$$bfi = b - 2 \cdot dfi = 18 - 2 \cdot 2,4 = 13,2 \text{ cm}$$

$$hfi = h - 2 \cdot dfi = 20 - 2 \cdot 2,4 = 15,2 \text{ cm}$$

Nagoreni opseg:

$$ur = 2 \cdot bfi + 2 \cdot hfi = 2 \cdot 13,2 + 2 \cdot 15,2 = 56,8 \text{ cm}$$

Površina nagorenog presjeka:

$$Ar = bfi \cdot hfi = 13,2 \cdot 15,2 = 200,64 \text{ cm}^2$$

Reducirani moment otpora:

$$W_{y,r} = W_{z,r} = \frac{bfi \cdot hfi^2}{6} = \frac{13,2 \cdot 15,2^2}{6} = 508,27 \text{ cm}^3$$

Proračun naprezanja nosača:

$$\sigma_{c,o,d,fi} = \frac{N_{c,o,d,fi}}{Ar} = \frac{14,89 \cdot 10^3}{200,64 \cdot 10^2} = 0,74 \text{ N/mm}^2$$

$$\sigma_{m,y,d,fi} = \frac{M_{y,d}}{W_{y,r}} = \frac{11,09 \cdot 10^6}{508,27 \cdot 10^3} = 21,82 \text{ N/mm}^2$$

$$\sigma_{m,z,d,fi} = \frac{M_{z,d}}{W_{z,r}} = \frac{2,69 \cdot 10^6}{508,27 \cdot 10^3} = 5,29 \text{ N/mm}^2$$

Karakteristične vrijednosti čvrstoća i modula elastičnosti:

$$f_{m,k} = 30 \text{ N/mm}^2$$

$$f_{t,0,k} = 19 \text{ N/mm}^2$$

$$f_{c,0,k} = 24 \text{ N/mm}^2$$

$$f_{v,k} = 4 \text{ N/mm}^2$$

$$E_{o,mean} = 12000 \text{ N/mm}^2$$

$$G_{mean} = 750 \text{ N/mm}^2$$

$$E_{0,05} = \frac{2}{3} \cdot E_{o,mean} = \frac{2}{3} \cdot 12000 = 8000 \text{ N/mm}^2$$

$$G_{0,05} = \frac{2}{3} \cdot G_{mean} = \frac{2}{3} \cdot 750 = 500 \text{ N/mm}^2$$

Proračunske vrijednosti čvrstoća i modula elastičnosti uz vrijednost koeficijenata modifikacije:

$k_{fi} = 1,25$ prijelaz na 20% fraktilu za LLD

$\gamma_{m,fi} = 1,0$ preporučena vrijednost parcijalnog faktora sigurnosti tijekom požara

$$\text{Savojna čvrstoća: } k_{mod,m,fi} = 1 - \frac{1}{200} * \frac{u_r}{A_r} = 1 - \frac{1}{200} * \frac{56,8 * 10^{-2}}{200,64 * 10^{-4}} = 0,858$$

$$\text{Tlačna čvrstoća: } k_{mod,c,fi} = 1 - \frac{1}{125} * \frac{u_r}{A_r} = 1 - \frac{1}{125} * \frac{56,8 * 10^{-2}}{200,64 * 10^{-4}} = 0,774$$

Vlačna čvrstoća i za E i G module:

$$k_{mod,t,fi} = k_{mod,E,fi} = k_{mod,G,fi} = 1 - \frac{1}{330} * \frac{u_r}{A_r} = 1 - \frac{1}{330} * \frac{56,8 * 10^{-2}}{200,64 * 10^{-4}} = 0,914$$

Vrijednosti:

$$f_{m,d,fi} = k_{mod,m,fi} * k_{fi} * \frac{f_{m,k}}{\gamma_{m,fi}} = 0,858 * 1,25 * \frac{30}{1} = 32,19 \text{ N/mm}^2$$

$$f_{c,d,fi} = k_{mod,c,fi} * k_{fi} * \frac{f_{m,k}}{\gamma_{m,fi}} = 0,774 * 1,25 * \frac{30}{1} = 29,01 \text{ N/mm}^2$$

$$E_{d,fi} = k_{mod,E,fi} * k_{fi} * \frac{E_{0,05}}{\gamma_{m,fi}} = 0,914 * 1,25 * \frac{8000}{1} = 9142,14 \text{ N/mm}^2$$

$$G_{d,fi} = k_{mod,G,fi} * k_{fi} * \frac{\frac{2}{3} G_{05}}{\gamma_{m,fi}} = 0,914 * 1,25 * \frac{\frac{2}{3} * 500}{1} = 380,92 \text{ N/mm}^2$$

Koeficijent izbočavanja oko osi: $k_{crit} = 1,0$

Dokaz nosivosti i stabilnosti:

$$\frac{\sigma_{m,y,d,fi}}{k_{crit} * f_{m,d,fi}} + k_{red} * \frac{\sigma_{m,z,d,fi}}{f_{m,z,d,fi}} + \frac{\sigma_{c,0,d,fi}}{k_c * f_{c,0,d,fi}} = \frac{21,82}{1 * 32,19} + 0,7 * \frac{5,29}{32,19} + \frac{0,74}{0,375 * 29,01} = 0,86 < 1$$

8. Vatrootpornost spojeva

8.1 Vatrootpornost detalja 1

DETALJ 1 (VLAČNI NASTAVKA DONJEG POJASA)

Osnovni materijal: puno drvo, 22/26cm, klasa čvrstoće C30, uporabna klasa 2

Djelovanja: $N_d=100,96$ kN

Tijesno ugrađeni vijci Φ 16mm (M16) kl. čvrstoće 5,6

Proračunska vrijednost vlačne sile:

$$F_{t,d} = \frac{F_d \cdot t}{2 \cdot a \cdot n}$$

$$F_d = \frac{N_d}{2} = \frac{100,96}{2} = 50,48 \text{ kN}$$

$$F_{t,d} = \frac{50,48 \cdot 1000}{2 \cdot 18 \cdot 100} = 1402,22 \text{ N}$$

Karakteristična vrijednosti nosivosti : $R_{ax,k} = 24710 \text{ N}$

Proračunska nosivost uslijed požara:

$$R_{ax,d,fi} = \eta \cdot \frac{k_{fi} \cdot R_k}{\gamma_{M,fi}}$$

$$\eta = e^{-k \cdot t_{d,fi}}$$

$$t_{d,fi} = -\frac{1}{k} \cdot \ln\left(\frac{\eta_{fi} \cdot \eta_0 \cdot k_{mod} \cdot \gamma_{m,fi}}{k_{fi} \cdot \gamma_m}\right)$$

$$t_{d,fi} = -\frac{1}{0,08} \cdot \ln\left(\frac{0,6 \cdot 1,0 \cdot 0,9 \cdot 1,0}{1,25 \cdot 1,1}\right) = 11,68 \text{ min}$$

$$\eta = e^{-0,08 \cdot 24,55} = 0,403$$

$$R_{ax,d,fi} = 0,403 \cdot \frac{1,25 \cdot 24710}{1,0} = 12447,66 \text{ N}$$

$$\text{Dokaz : } \frac{F_{t,d}}{R_{ax,d,fi}} = \frac{1402,22}{12447,66} = 0,113 \rightarrow \text{zadovoljava}$$

k_{fi} – parametar $\rightarrow 0,08$

η_{fi} – faktor smanjenja za proračunsko opterećenje u požarnoj situaciji $\rightarrow 0,6$

η_0 – stupanj primjenjivosti pri uobičajenoj temperaturi $\rightarrow 1,0$

k_{mod} – faktor izmjene $\rightarrow 0,9$

γ_m – parcijalni koeficijent za spoj $\rightarrow 1,1$

k_{fi} – vrijednost u skladu s točkom $\rightarrow 1,25$

$\gamma_{m,fi}$ – parcijalni koeficijent sigurnosti za drvo u požaru $\rightarrow 1,0$

8.2 Vatrootpornost detalja 2

DETALJ 2 (DVOSTRUKI ZASJEK)

$$N_d = 105,74 \text{ kN}$$

$$t_{v,\max} = \frac{h}{4} = \frac{26}{4} = 6,5 \text{ cm}$$

$$t_{v,1} = 6 \text{ cm} < 7,5 \text{ cm}$$

$$t_{v,2} = 5,5 \text{ cm} < 7,5 \text{ cm}$$

$$\gamma = 17^\circ, \alpha = 8,5^\circ$$

Osiguranje M 12 – KONSTRUKTIVNO

PREDNJI ZASJEK

$$R_{1,d} = f_{c,\alpha,d} \cdot A_1$$

$$f_{c,0,d,fi} = k_{mod,fi} \cdot k_{fi} \cdot \frac{f_{c,0,k}}{\gamma_{m,fi}} = 0,857 \cdot 1,25 \cdot \frac{24}{1,0} = 19,78 \text{ N/mm}^2$$

$$f_{c,\alpha,d,fi} = \frac{f_{c,0,d,fi}}{\sqrt{\left(\frac{f_{c,0,d,fi}}{2 \cdot f_{c,90,d,fi}} \cdot \sin^2 \alpha\right)^2 + \left(\frac{f_{c,0,d,fi}}{2 \cdot f_{v,d}} \cdot \sin \alpha \cdot \cos \alpha\right)^2 + \cos^4 \alpha}}$$

$$f_{c,\alpha,d} = 18,38 \text{ N/mm}^2$$

$$A_1 = \frac{b_1 \cdot t_{v,1}}{\cos \alpha} = \frac{17,8 \cdot 6}{\cos 8,5} = 107,99 \text{ cm}^2$$

$$R_{1,d} = 19,78 \cdot 10^{-1} \cdot 107,99 = 213,60 \text{ kN}$$

$$R_{1,d,stv} = \frac{R_{1,d}}{\cos 8,5} = \frac{213,6}{\cos 8,5} = 215,97 \text{ kN}$$

STRAŽNJI ZASJEK

$$R_{2,d} = f_{c,\alpha,d} \cdot A_2$$

$$f_{c,\alpha,d} = \frac{f_{c,0,d}}{\sqrt{\left(\frac{f_{c,0,d}}{2 \cdot f_{c,90,d}} \cdot \sin^2 \alpha\right)^2 + \left(\frac{f_{c,0,d}}{2 \cdot f_{v,d}} \cdot \cos \alpha \cdot \sin \alpha\right)^2 + \cos^4 \alpha}}$$

$$f_{c,\alpha,d} = \frac{19,78}{\sqrt{\left(\frac{19,78}{2 \cdot 2,22} \cdot \sin^2 17\right)^2 + \left(\frac{19,78}{2 \cdot 3,3} \cdot \cos 17 \cdot \sin 17\right)^2 + \cos^4 17}}$$

$$f_{c,\alpha,d} = 15,25 \text{ N/mm}^2$$

$$A_2 = \frac{b_2 \cdot t_{v,2}}{\cos \alpha} = \frac{17,8 \cdot 5,5}{\cos 17} = 102,37 \text{ cm}^2$$

$$R_{2,d} = 15,25 \cdot 10^{-1} \cdot 102,37 = 156,11 \text{ kN}$$

$$R_{2,d,stv} = R_{2,d}$$

$$R_{tot,d} = R_{1,d,stv} + R_{2,d,stv} = 215,97 + 156,11 = 372,08$$

$$\text{Dokaz: } \frac{105,74}{372,08} = 0,284 < 1 \quad (28,4\%)$$

8.3 Vatrootpornost detalja 3

DETALJ 3 – ZASJEK I BUŠENI ČAVLI

GP 22/28 cm

dijagonala 22/12

vertikala 2x12/12

$$t_{v,\max} = \frac{h}{6} = \frac{28}{6} = 4,7 \text{ cm}$$

$$t_v = 2,5 \text{ cm} < 4,7 \text{ cm}$$

Osiguranje M12- konstruktivno

$$f_{c, \alpha, d, fi} = \frac{f_{c, o, d}}{\sqrt{\left(\frac{f_{c, o, d}}{2 \cdot f_{c, 90, d}} \cdot \sin^2 \alpha\right)^2 + \left(\frac{f_{c, o, d}}{2 \cdot f_{v, d}} \cdot \cos \alpha \cdot \sin \alpha\right)^2 + \cos^4 \alpha}}$$

$$f_{c, \alpha, d, fi} = \frac{19,78}{\sqrt{\left(\frac{19,78}{2 \cdot 2,22} \cdot \sin^2 17\right)^2 + \left(\frac{19,78}{2 \cdot 3,3} \cdot \cos 17 \cdot \sin 17\right)^2 + \cos^4 17}}$$

$$f_{c, \alpha, d, fi} = 15,25 \text{ N/mm}^2$$

$$A_1 = \frac{b_1 \cdot t_{v,1}}{\cos \alpha} = \frac{17,8 \cdot 2,5}{\cos 17} = 46,53 \text{ cm}^2$$

$$\sigma'_{1,d} = \frac{N_{c,d} \cdot \cos \alpha}{A_1} = \frac{16,21 \cdot \cos 17}{46,53} \cdot 10 = 3,33 \text{ N/mm}$$

$$\text{Dokaz: } \frac{\sigma'_{1,d}}{f_{c, \alpha, d}} = \frac{3,33}{15,25} = 0,22 < 1 \quad (22\%)$$

Bušeni čavli 6/180

$$f_{u,k} = 600 \text{ N/mm}^2$$

$$F_d = 0,23 \text{ kN}, \quad \alpha = 73^\circ$$

Karakteristična vrijednost nosivosti:

$$R_k = 2583,35 \text{ N}$$

Proračunska nosivost uslijed požara:

$$R_{d,fi} = \eta \cdot \frac{k_{fi} \cdot R_k}{\gamma_{M,fi}}$$

$$\eta = e^{-k \cdot t_{d,fi}}$$

$$t_{d,fi} = -\frac{1}{k} \cdot \ln \left(\frac{\eta_{fi} \cdot \eta_0 \cdot k_{mod} \cdot \gamma_{m,fi}}{k_{fi} \cdot \gamma_m} \right)$$

$$t_{d,fi} = -\frac{1}{0,08} \cdot \ln \left(\frac{0,6 \cdot 1,0 \cdot 0,9 \cdot 1,0}{1,25 \cdot 1,1} \right) = 11,68 \text{ min}$$

$$\eta = e^{-0,08 \cdot 24,55} = 0,403$$

$$R_{d,fi} = 0,403 \cdot \frac{1,25 \cdot 2583,35}{1,0} = 1301,36 \text{ N}$$

$$\text{Dokaz: } \frac{F_{t,d}}{R_{d,fi} \cdot n} = \frac{2,28}{1,301 \cdot 2} = 0,876 \rightarrow \text{zadovoljava}$$

(87,6%)

8.4 Vatrootpornost detalja 4

DETALJ 4 – bušeni čavli

Vertikala 2x20/12

DP 22/26 cm

Fd=3,9 kN

Čavli 6/180 mm, $f_{u,k}=600 \text{ N/mm}^2$

$$R_k = 2583,35 \text{ N}$$

Proračunska nosivost uslijed požara:

$$R_{d,fi} = \eta \cdot \frac{k_{fi} \cdot R_k}{\gamma_{M,fi}}$$

$$\eta = e^{-k \cdot t_{d,fi}}$$

$$t_{d,fi} = -\frac{1}{k} \cdot \ln \left(\frac{\eta_{fi} \cdot \eta_0 \cdot k_{mod} \cdot \gamma_{m,fi}}{k_{fi} \cdot \gamma_m} \right)$$

$$t_{d,fi} = -\frac{1}{0,08} \cdot \ln \left(\frac{0,6 \cdot 1,0 \cdot 0,9 \cdot 1,0}{1,25 \cdot 1,1} \right) = 11,68 \text{ min}$$

$$\eta = e^{-0,08 \cdot 24,55} = 0,403$$

$$R_{d,fi} = 0,403 \cdot \frac{1,25 \cdot 2583,35}{1,0} = 1301,36 \text{ N}$$

$$\text{Dokaz: } \frac{F_{t,d}}{R_{d,fi} \cdot n} = \frac{0,54}{1,301 \cdot 2} = 0,21 \rightarrow \text{zadovoljava}$$

(21%)

8.5 Vatrootpornost detalja 5

DETALJ 5 - TIJESNO UGRAĐENI VIJCI

GP 22/28 cm

dijagonala 22/12

vertikala 2x12/12

$$t_{v,max} = \frac{h}{6} = \frac{28}{6} = 4,7 \text{ cm}$$

$$t_v = 2,5 \text{ cm} < 4,7 \text{ cm}$$

Osiguranje M12- konstruktivno

$$f_{c,\alpha,d,fi} = \frac{f_{c,o,d}}{\sqrt{\left(\frac{f_{c,o,d}}{2 \cdot f_{c,90,d}} \cdot \sin^2 \alpha\right)^2 + \left(\frac{f_{c,o,d}}{2 \cdot f_{v,d}} \cdot \cos \alpha \cdot \sin \alpha\right)^2 + \cos^4 \alpha}}$$

$$f_{c,\alpha,d,fi} = \frac{19,78}{\sqrt{\left(\frac{19,78}{2 \cdot 2,22} \cdot \sin^2 24\right)^2 + \left(\frac{19,78}{2 \cdot 3,3} \cdot \cos 24 \cdot \sin 24\right)^2 + \cos^4 24}}$$

$$f_{c,\alpha,d,fi} = 12,1 \text{ N/mm}^2$$

$$A_1 = \frac{b_1 \cdot t_{v,1}}{\cos \alpha} = \frac{17,8 \cdot 2,5}{\cos 24} = 46,53 \text{ cm}^2$$

$$\sigma_{1,d} = \frac{N_{c,d} \cdot \cos \alpha}{A_1} = \frac{24,53 \cdot \cos 17}{46,53} \cdot 10 = 5,04 \text{ N/mm}$$

$$\text{Dokaz: } \frac{\sigma_{1,d}}{f_{c,\alpha,d}} = \frac{5,04}{12,1} = 0,417 < 1 \quad (41,7\%)$$

Tijesno ugrađeni vijci PB ϕ 12-10,9 ; $f_{u,k} = 1000 \text{ N/mm}^2$

$$F_d = 7,36 \text{ kN}, \quad \alpha = 73^\circ$$

Karakteristična vrijednost nosivosti:

$$R_k = 9222,22 \text{ N}$$

Proračunska nosivost uslijed požara:

$$R_{d,fi} = \eta \cdot \frac{k_{fi} \cdot R_k}{\gamma_{M,fi}}$$

$$\eta = e^{-k \cdot t_{d,fi}}$$

$$t_{d,fi} = -\frac{1}{k} \cdot \ln \left(\frac{\eta_{fi} \cdot \eta_0 \cdot k_{mod} \cdot \gamma_{m,fi}}{k_{fi} \cdot \gamma_m} \right)$$

$$t_{d,fi} = -\frac{1}{0,08} \cdot \ln \left(\frac{0,6 \cdot 1,0 \cdot 0,9 \cdot 1,0}{1,25 \cdot 1,1} \right) = 11,68 \text{ min}$$

$$\eta = e^{-0,08 \cdot 24,55} = 0,403$$

$$R_{d,fi} = 0,403 \cdot \frac{1,25 \cdot 9222,22}{1,0} = 4645,69 \text{ N} \quad \checkmark$$

$$\text{Dokaz: } \frac{F_{t,d}}{R_{d,fi} \cdot n} = \frac{7,36}{4,646 \cdot 2} = 0,79 \rightarrow \text{zadovoljava} \\ (79\%)$$

8.6 Vatrootpornost detalja 6

DETALJ 6 – ZASJEK I TIJESNO UGRAĐENI VIJCI

DP 22/26 cm

dijagonala 22/12

vertikala 2x12/12

$$t_{v,max} = \frac{h}{4} = \frac{26}{4} = 6,5 \text{ cm}$$

$$t_v = 6 \text{ cm} < 6,5 \text{ cm}$$

Osiguranje M12- konstruktivno

$$f_{c, \alpha, d, fi} = \frac{f_{c, o, d}}{\sqrt{\left(\frac{f_{c, o, d}}{2 \cdot f_{c, 90, d}} \cdot \sin^2 \alpha\right)^2 + \left(\frac{f_{c, o, d}}{2 \cdot f_{v, d}} \cdot \cos \alpha \cdot \sin \alpha\right)^2 + \cos^4 \alpha}}$$

$$f_{c, \alpha, d, fi} = \frac{19,78}{\sqrt{\left(\frac{19,78}{2 \cdot 2,22} \cdot \sin^2 8,5\right)^2 + \left(\frac{19,78}{2 \cdot 3,3} \cdot \cos 8,5 \cdot \sin 8,5\right)^2 + \cos^4 8,5}}$$

$$f_{c, \alpha, d, fi} = 18,38 \text{ N/mm}^2$$

$$A_1 = \frac{b_1 \cdot t_{v,1}}{\cos \alpha} = \frac{17,8 \cdot 6}{\cos 8,5} = 107,99 \text{ cm}^2$$

$$\sigma_{1,d} = \frac{N_{c,d} \cdot \cos \alpha}{A_1} = \frac{16,48 \cdot \cos 8,5}{107,99} \cdot 10 = 1,51 \text{ N/mm}$$

$$\text{Dokaz: } \frac{\sigma_{1,d}}{f_{c, \alpha, d}} = \frac{1,51}{18,38} = 0,12 < 1 \quad (12\%)$$

Tijesno ugrađeni vijci PB ϕ 12-8,8 ; $f_{u,k} = 800 \text{ N/mm}^2$

$$F_d = 6,82 \text{ kN}, \quad \alpha = 90^\circ$$

Karakteristična vrijednost nosivosti:

$$R_k = 8124,86 \text{ N}$$

Proračunska nosivost uslijed požara:

$$R_{d,fi} = \eta \cdot \frac{k_{fi} \cdot R_k}{\gamma_{M,fi}}$$

$$\eta = e^{-k \cdot t_{d,fi}}$$

$$t_{d,fi} = -\frac{1}{k} \cdot \ln \left(\frac{\eta_{fi} \cdot \eta_0 \cdot k_{mod} \cdot \gamma_{m,fi}}{k_{fi} \cdot \gamma_m} \right)$$

$$t_{d,fi} = -\frac{1}{0,08} \cdot \ln \left(\frac{0,6 \cdot 1,0 \cdot 0,9 \cdot 1,0}{1,25 \cdot 1,1} \right) = 11,68 \text{ min}$$

$$\eta = e^{-0,08 \cdot 24,55} = 0,403$$

$$R_{d,fi} = 0,403 \cdot \frac{1,25 \cdot 8124,86}{1,0} = 4092,9 \text{ N}$$

$$\text{Dokaz: } \frac{F_{t,d}}{R_{d,fi} \cdot n} = \frac{6,82}{4,093 \cdot 2} = 0,83 \rightarrow \text{zadovoljava}$$

(83%)

8.7 Vatrootpornost detalja 7

DETALJ 7 – TIJESNO UGRAĐENI VIJCI

Tijesno ugrađeni vijci PBφ12-8,8 ; $f_{u,k} = 800 \text{ N/mm}^2$

$F_d = 27,39 \text{ kN}$

Karakteristična vrijednost nosivosti:

$$R_k = 7899,57 \text{ N}$$

Proračunska nosivost uslijed požara:

$$R_{d,fi} = \eta \cdot \frac{k_{fi} \cdot R_k}{\gamma_{M,fi}}$$

$$\eta = e^{-k \cdot t_{d,fi}}$$

$$t_{d,fi} = -\frac{1}{k} \cdot \ln \left(\frac{\eta_{fi} \cdot \eta_0 \cdot k_{mod} \cdot \gamma_{m,fi}}{k_{fi} \cdot \gamma_m} \right)$$

$$t_{d,fi} = -\frac{1}{0,08} \cdot \ln \left(\frac{0,6 \cdot 1,0 \cdot 0,9 \cdot 1,0}{1,25 \cdot 1,1} \right) = 11,68 \text{ min}$$

$$\eta = e^{-0,08 \cdot 24,55} = 0,403$$

$$R_{d,fi} = 0,403 \cdot \frac{1,25 \cdot 7899,57}{1,0} = 3979,41 \text{ N}$$

$$\text{Dokaz: } \frac{F_{t,d}}{R_{d,fi} \cdot n} = \frac{27,39}{3,979 \cdot 8} = 0,86 \rightarrow \text{zadovoljava}$$

(86%)

8.8 Vatrootpornost detalja 8

DETALJ 8 – JEDNOSTRUKI ZASJEK I TIJESNO UGRAĐENI VIJCI

DP 22/26 cm

dijagonala 22/12

vertikala 2x12/12

$$t_{v,max} = \frac{h}{6} = \frac{26}{6} = 4,3 \text{ cm}$$

$$t_v = 3,5 \text{ cm} < 4,3 \text{ cm}$$

Osiguranje M12- konstruktivno

$$f_{c, \alpha, d, fi} = \frac{f_{c, o, d}}{\sqrt{\left(\frac{f_{c, o, d}}{2 \cdot f_{c, 90, d}} \cdot \sin^2 \alpha\right)^2 + \left(\frac{f_{c, o, d}}{2 \cdot f_{v, d}} \cdot \cos \alpha \cdot \sin \alpha\right)^2 + \cos^4 \alpha}}$$

$$f_{c, \alpha, d, fi} = \frac{19,78}{\sqrt{\left(\frac{19,78}{2 \cdot 2,22} \cdot \sin^2 15,5\right)^2 + \left(\frac{19,78}{2 \cdot 3,3} \cdot \cos 15,5 \cdot \sin 15,5\right)^2 + \cos^4 15,5}}$$

$$f_{c, \alpha, d, fi} = 15,84 \text{ N/mm}^2$$

$$A_1 = \frac{b_1 \cdot t_{v,1}}{\cos \alpha} = \frac{17,8 \cdot 3,5}{\cos 15,5} = 64,65 \text{ cm}^2$$

$$\sigma_{1,d} = \frac{N_{c,d} \cdot \cos \alpha}{A_1} = \frac{25,07 \cdot \cos 15,5}{64,65} \cdot 10 = 3,74 \text{ N/mm}$$

$$\text{Dokaz: } \frac{\sigma_{1,d}}{f_{c, \alpha, d}} = \frac{3,74}{25,07} = 0,150 < 1 \quad (15\%)$$

Tijesno ugrađeni vijci PB ϕ 12-8,8 ; $f_{u,k} = 800 \text{ N/mm}^2$

$$F_d = 26,57 \text{ kN}, \quad \alpha = 90^\circ$$

Karakteristična vrijednost nosivosti:

$$R_k = 8124,86 \text{ N}$$

Proračunska nosivost uslijed požara:

$$R_{d,fi} = \eta \cdot \frac{k_{fi} \cdot R_k}{\gamma_{M,fi}}$$

$$\eta = e^{-k \cdot t_{d,fi}}$$

$$t_{d,fi} = -\frac{1}{k} \cdot \ln \left(\frac{\eta_{fi} \cdot \eta_0 \cdot k_{mod} \cdot \gamma_{m,fi}}{k_{fi} \cdot \gamma_m} \right)$$

$$t_{d,fi} = -\frac{1}{0,08} \cdot \ln \left(\frac{0,6 \cdot 1,0 \cdot 0,9 \cdot 1,0}{1,25 \cdot 1,1} \right) = 11,68 \text{ min}$$

$$\eta = e^{-0,08 \cdot 24,55} = 0,403$$

$$R_{d,fi} = 0,403 \cdot \frac{1,25 \cdot 8124,86}{1,0} = 4092,9 \text{ N}$$

$$\text{Dokaz: } \frac{F_{t,d}}{R_{d,fi} \cdot n} = \frac{26,57}{4,093 \cdot 8} = 0,81 \rightarrow \text{zadovoljava} \\ (81\%)$$

9. Nacrti

1. GENERALNI PLAN POZICIJA (M 1:100)
2. RADIONIČKI NACRT GLAVNOG NOSAČA (M 1:25)
3. DETALJ 1 (M 1:10)
4. DETALJ 2 (M 1:10)
5. DETALJ 3 (M 1:10)
6. DETALJ 4 (M 1:10)
7. DETALJ 5 (M 1:10)
8. DETALJ 6 (M 1:10)
9. DETALJ 7 (M 1:10)
10. DETALJ 8 (M 1:10)

7. NACRTI
7.1 GENERALNI PLAN POZICIJA
M 1:100

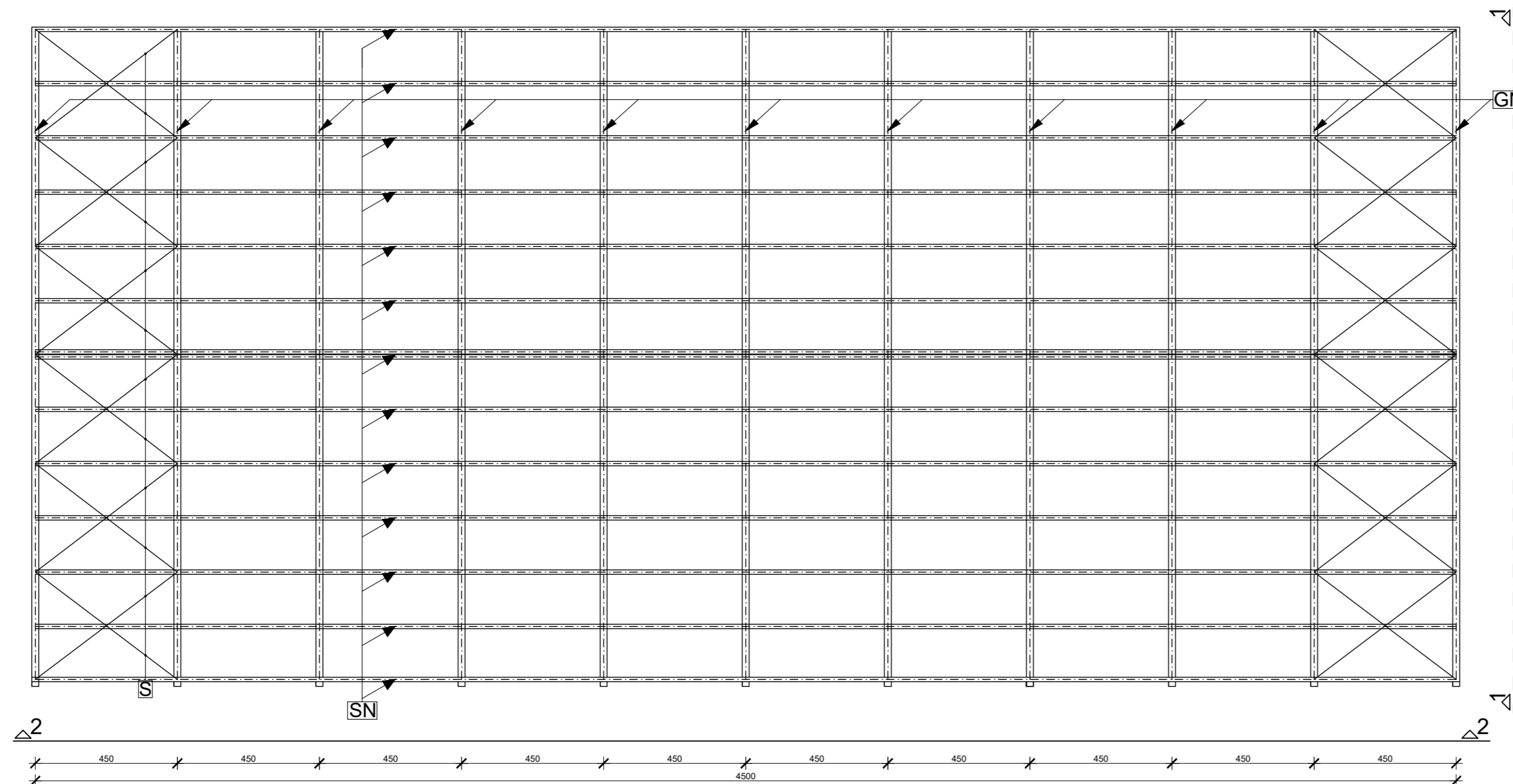

POGLED 2-2

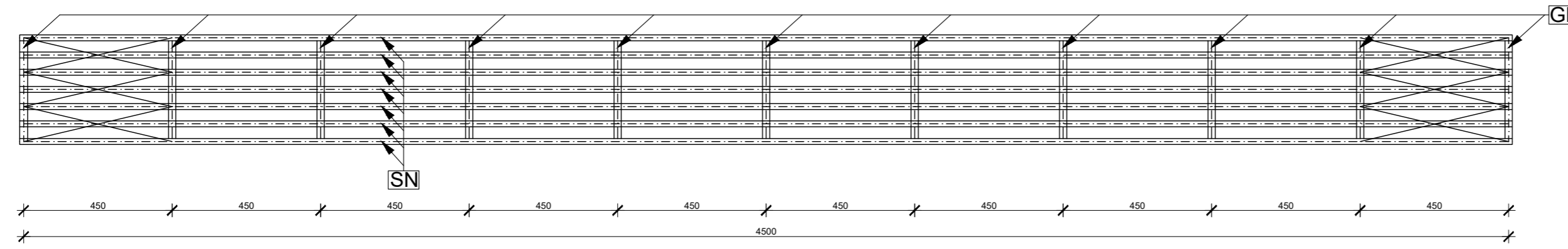

POGLED 1-1

OZNAKA	DIMENZIJA	OPIS
GN	—	GLAVNI NOSAČ
GP	22/28	GORNJI POJAS
DP	22/26	DONJI POJAS
D ₁ , D ₂	22/12	DIJAGONALA
V ₁ , V ₂ , V ₃	20/12	VERTIKALA
SN	18/20	SEKUNDARNI NOSAČ
S	Ø10	SPREG

Sveučilište u Splitu, Fakultet građevinarstva, arhitekture i geodezije
Matije hrvatske 15, HR 21000, SPLIT gradst.unist.hr
PREDDIPLOMSKI SVEUČILIŠNI STUDIJ GRAĐEVINARSTVA
PREDMET: OSNOVE DRVENIH KONSTRUKCIJA
STUDENTI: ANTONIJA LEMO
SADRŽAJ: Generalni plan pozicija ak. god.: 2023./2024.

DETALJ SPOJA DONJEG POJASA M 1:10

POGLED 1-1

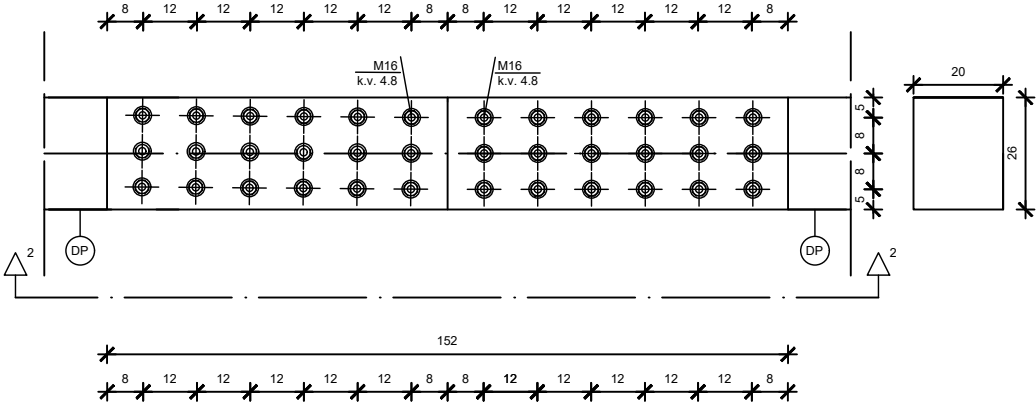

POGLED 2-2

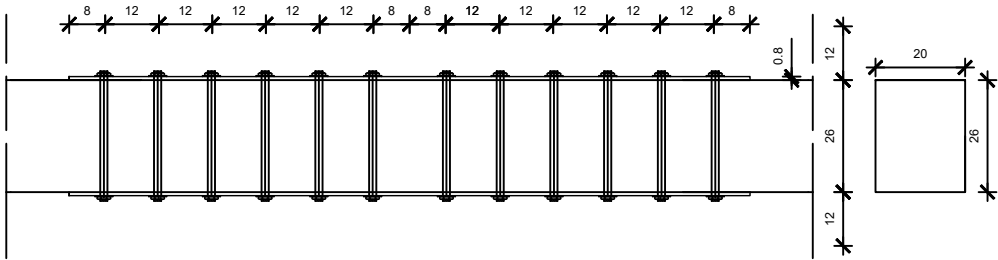

	Sveučilište u Splitu, Fakultet građevinarstva, arhitekture i geodezije Matice hrvatske 15, HR 21000, SPLIT gradst.unist.hr
	PREDDIPLOMSKI SVEUČILIŠNI STUDIJ GRAĐEVINARSTVA
PREDMET: OSNOVE DRVENIH KONSTRUKCIJA	
STUDENT: ANTONIJA LEMO	
SADRŽAJ: Detalji spoja donjeg pojasa ak. god.: 2023./2024.	

DETALJ 2
M 1:10

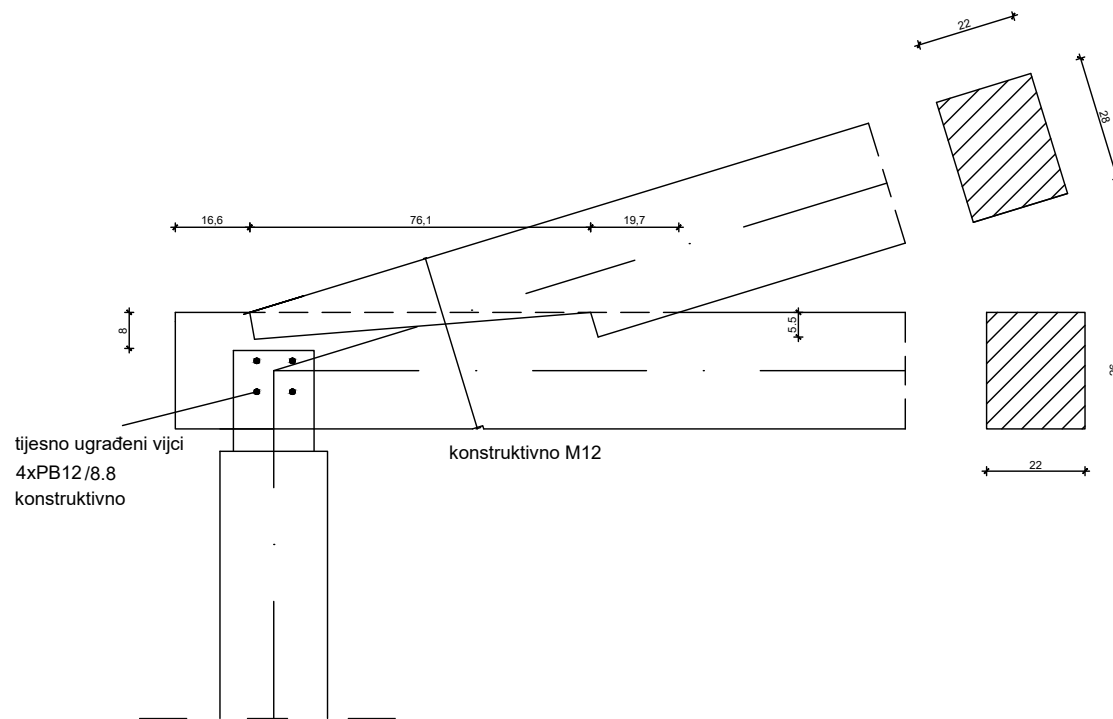

DETALJ 3
M 1:10

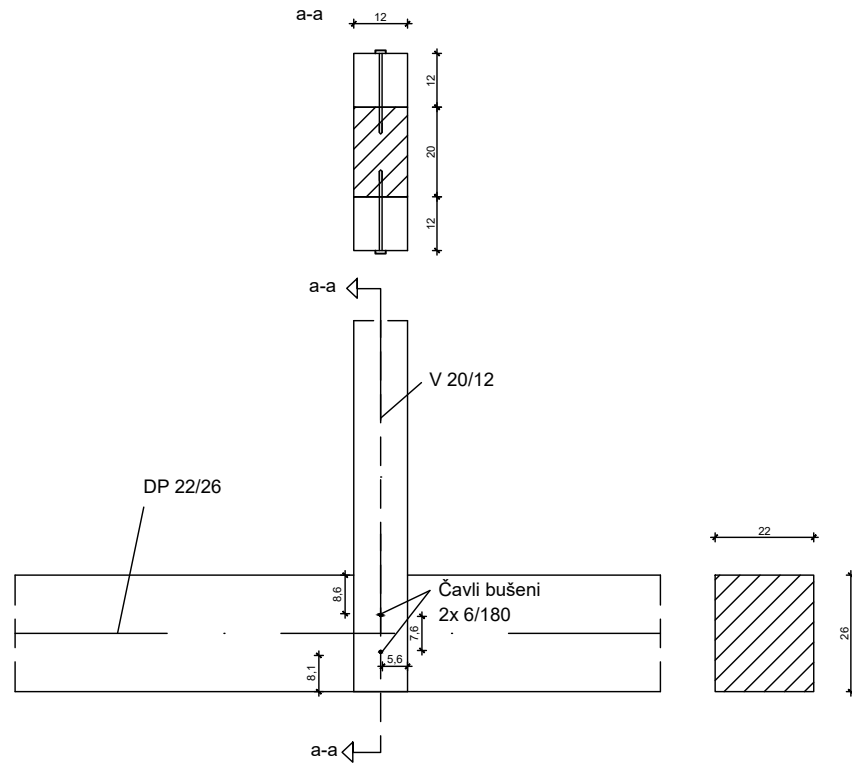

DETALJ 4
M 1:10

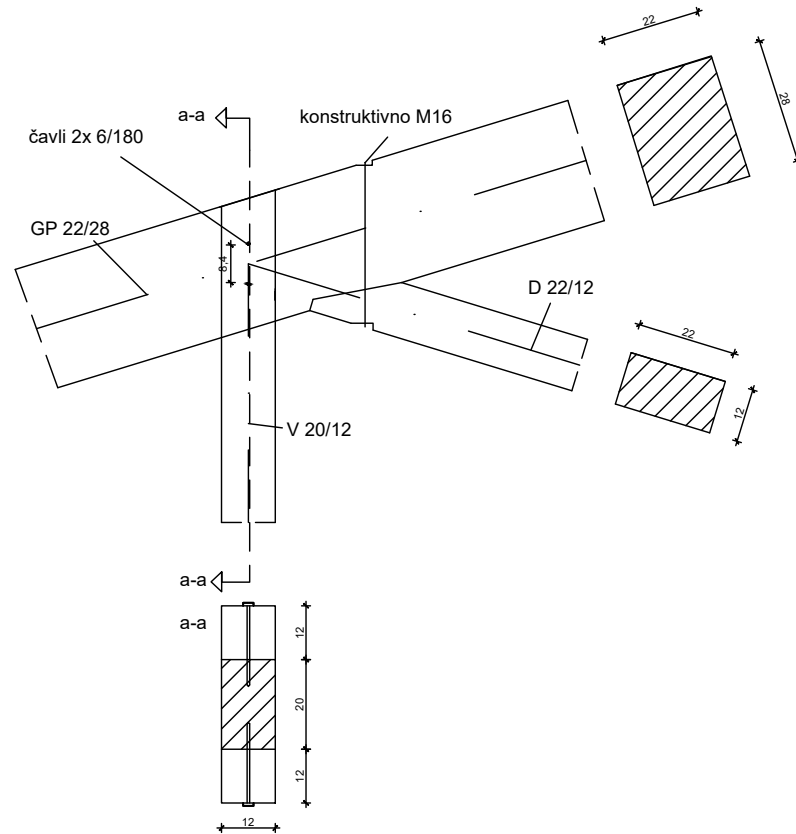

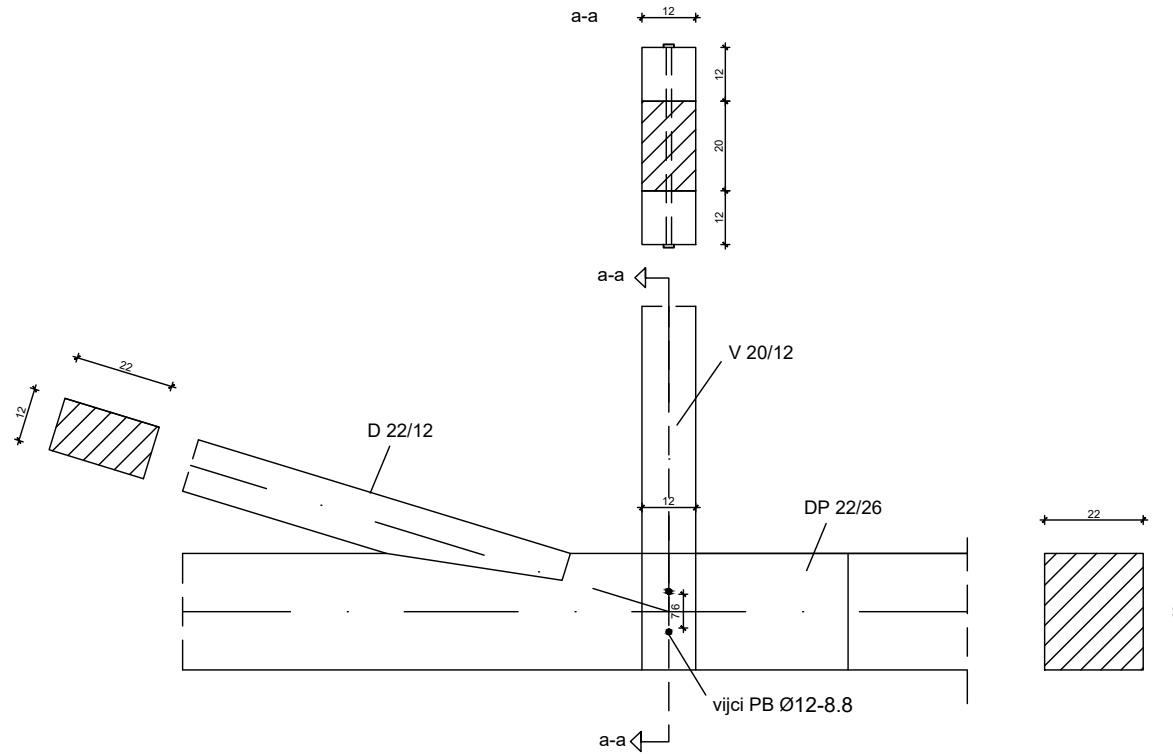

DETALJ 5
M 1:10

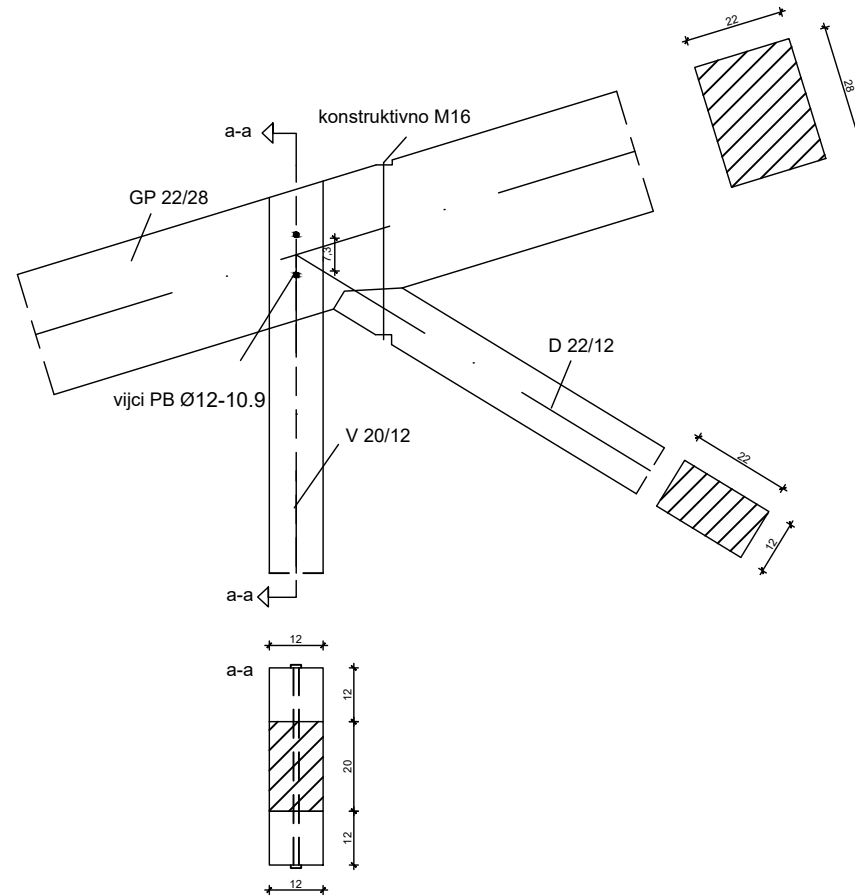

	Sveučilište u Splitu, Fakultet građevinarstva, arhitekture i geodezije Matice hrvatske 15, HR 21000, SPLIT gradst.unist.hr
PREDDIPLOMSKI SVEUČILIŠNI STUDIJ GRAĐEVINARSTVA	
PREDMET: OSNOVE DRVENIH KONSTRUKCIJA	
STUDENT: ANTONIJA LEMO	
SADRŽAJ: Detalj spoja 5	ak. god.: 2023./2024.

DETALJ 6
M 1:10



	Sveučilište u Splitu, Fakultet građevinarstva, arhitekture i geodezije Matice hrvatske 15, HR 21000, SPLIT gradst.unist.hr
PREDDIPLOMSKI SVEUČILIŠNI STUDIJ GRAĐEVINARSTVA	
PREDMET: OSNOVE DRVENIH KONSTRUKCIJA	
STUDENT: ANTONIJA LEMO	
SADRŽAJ: Detalj spoja 6	ak. god.: 2023./2024.

DETALJ 8
M 1:10

